



# Service Kit 759-04260

Date: March 1, 2010

Subject: Service Replacement for the  
603-0363A-0650 Caster Weldment  
Assembly

Models ZT-17, ZT-22, ZT-42 and ZT-50  
Affected:

**Read through and understand these instructions completely before proceeding.**

**PURPOSE:** This kit provides the new style 603-04308 Caster Weldment Assembly and hardware to replace the 603-0363A Caster Weldment Assembly which is no longer available.

**NOTE:** *These materials are prepared for use by trained technicians who are experienced in the service and repair of equipment of the kind described in this publication, and are not intended for use by untrained or inexperienced individuals. Such individuals should seek the assistance of an authorized service technician or dealer.*

**NOTE:** *Save this Instruction Sheet. Refer to it when ordering replacement parts.*

## Service Kit Contents (See Figure 1)

ITEM NO.	PART NUMBER	QTY	DESCRIPTION
1	603-04308-0650	1	WELDMENT: CASTER (RED METALLIC)
2	738-04182A	1	BOLT: SHOULDER: .750" x 4.75" x 1/2"-13
3	712-3022	1	NUT: HEXLK: 1/2"-13: GRB: CENTERLOCK
4	*	1	THIS INSTRUCTION SHEET

\* - Not Available Separately

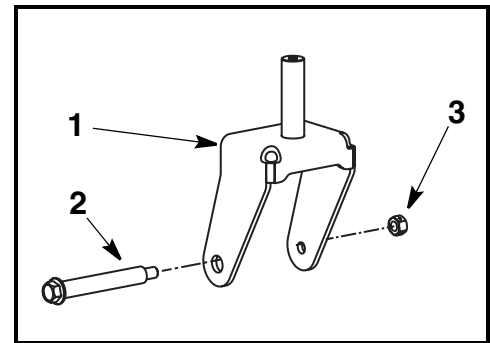

FIGURE 1

## INSTALLATION:

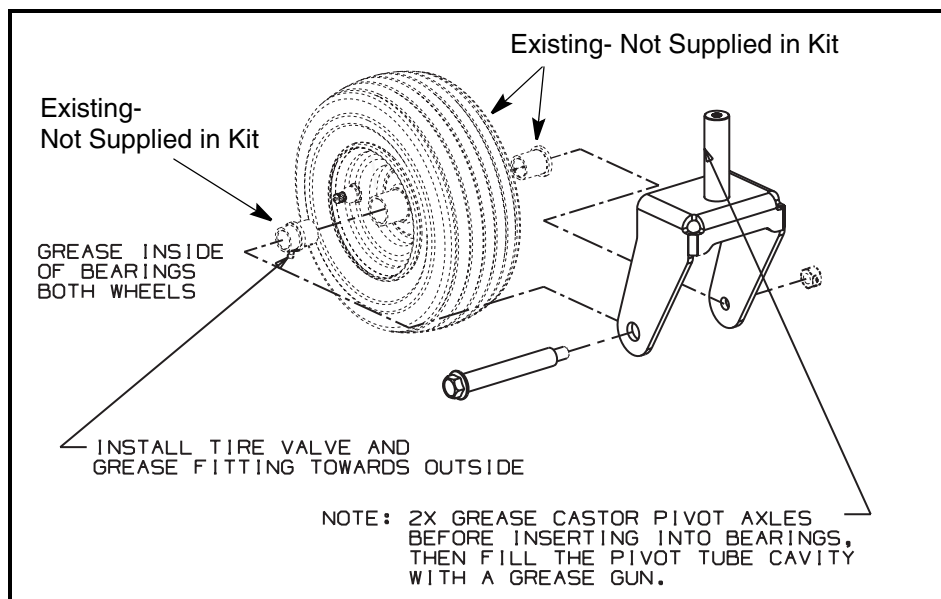

FIGURE 2