



Service Kit 753-05922

Date: 5/15/2008 (Revised 7/08/2009)

Subject: Service Replacement for the
682-3057A and/or 682-3056A Handle
Brackets

Models: 500 Series Walk Behind Mowers with
Affected: Steel Rear Door

Read through and understand these instructions completely before proceeding with repair.

PURPOSE: This service kit is the replacement for the 682-3057A (Left Hand) and/or 682-3056A (Right Hand) handle bracket which are no longer available.

NOTE: If after installing this kit, your existing bagger frame does not allow the new rear door to seat properly on the bagger frame, a new frame and bag will be required. See page 3.

NOTE: These materials are prepared for use by trained technicians who are experienced in the service and repair of equipment of the kind described in this publication, and are not intended for use by untrained or inexperienced individuals. Such individuals should seek the assistance of an authorized service technician or dealer.

NOTE: Save this Instruction Sheet. Refer to it when ordering replacement parts.

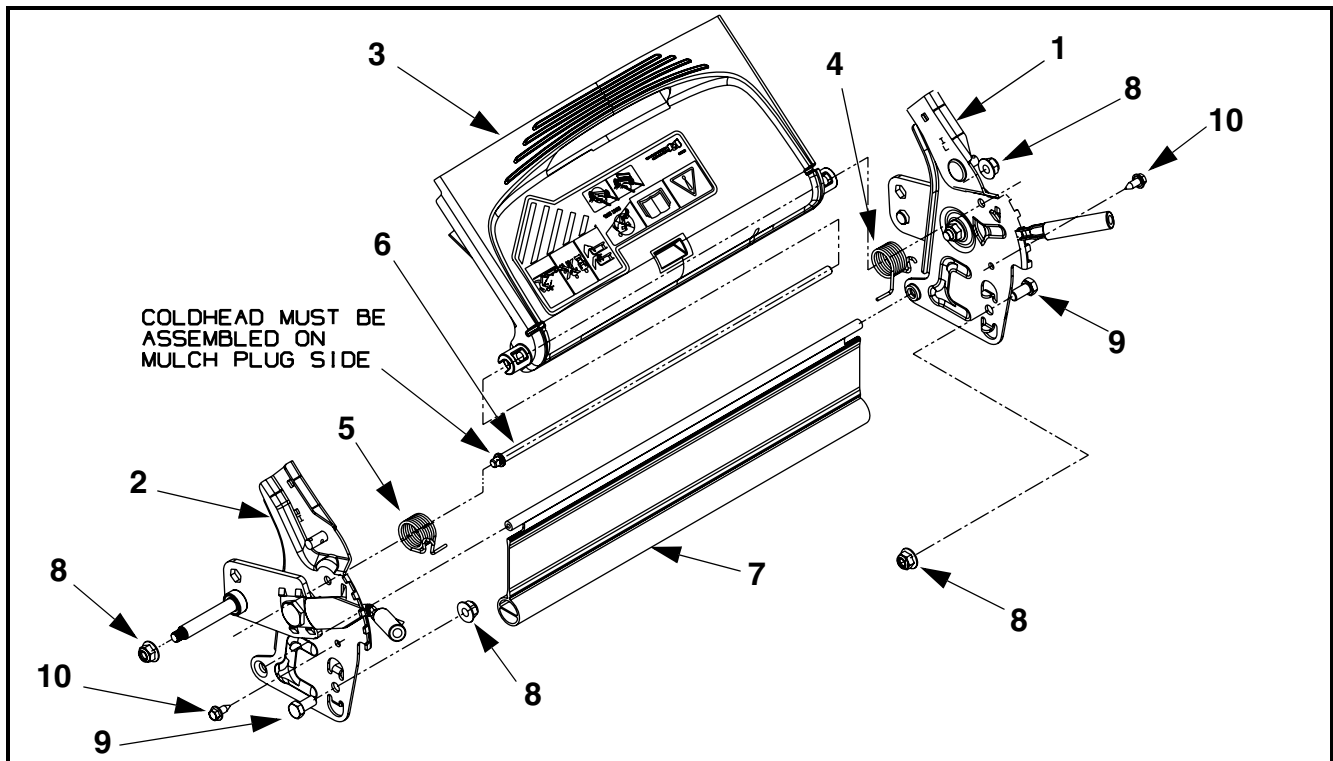

FIGURE 1

Service Kit Contents (See Figure 1)

* - Not Available Separately

ITEM NO.	PART NUMBER	QTY	DESCRIPTION
1	987-02280A	1	BRACKET: HANDLE: LH
2	987-02279A	1	BRACKET: HANDLE: RH
3	731-05865	1	DOOR: REAR: PLASTIC
4	732-04089A	1	SPRING: TORSION: DOOR: LH
5	732-04090A	1	SPRING: TORSION: DOOR: RH
6	747-04588	1	ROD: PIVOT: DOOR: REAR
7	731-05642	1	SHIELD: TRAIL
8	712-04065	4	NUT: FLANGELOCK: 3/8-16: GRF: NYLON
9	710-0216	2	HHCS: 3/8-16 x .75: GR5: STD
10	710-1652	2	SCREW: TAPTITE: 1/4-20 x .625: HXINDSH
	*	1	THIS INSTRUCTION SHEET

Pre-service Preparation:

1. Place mower on a flat and level surface.
2. Turn off engine and allow muffler and engine to fully cool before proceeding.
3. Remove the spark plug wire from the spark plug and ground wire to engine block.
4. Place wood blocking under the rear of the deck to support the wheels off of the ground.

Installation Guidelines:

5. Remove the upper and lower handles (as an assembly) from the LH and RH handle brackets. Save all hardware.
6. Remove the wheels from the height adjusters. Discard the lock nuts.
7. Remove and discard the existing left and right side handle brackets, rear door, door pivot rod, door return spring(s), trail shield and hardware.

NOTE: Refer to Figure 1 for the following steps.

8. Install the Right Hand Handle Bracket, Item 2, to the deck first, using the **new** hardware supplied.
9. Slide the Rear Door Pivot Rod, Item 6, through the Plastic Door's upper hinges. Ensure that the coldhead end of the pivot rod is towards the RH handle bracket (mulch plug side). See Figure 1.
10. Assemble the LH and RH Torsion Door Springs, Items 4 and 5, onto the pivot rod/door subassembly, ensuring the spring's straight arm is inserted in the door's molded in pocket. See Figure 2.

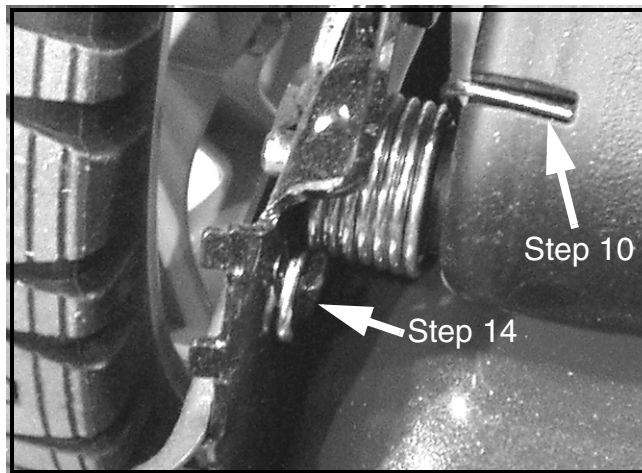
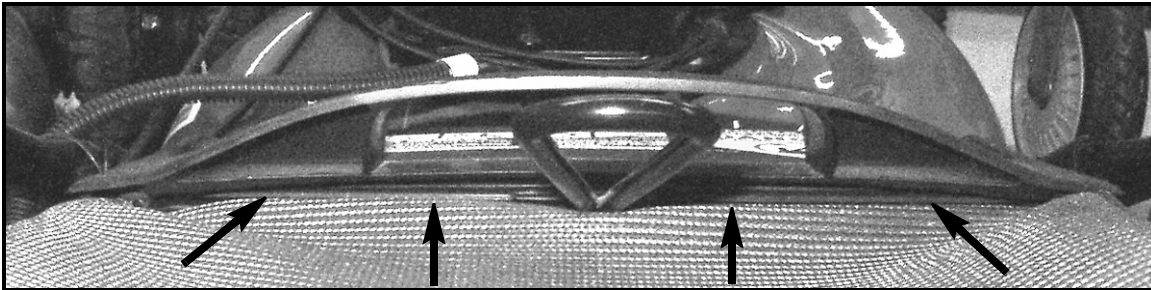

FIGURE 2

11. Install the trail shield pivot rod into the RH handle bracket's trail shield hole. See Figure 1.
12. Insert the left hand ends of the rear door pivot rod (with torsion spring in place) and trail shield into the LH Handle Bracket, Item 1.
13. Align the LH handle bracket to the deck and secure using the **new** hardware supplied.
14. With the rear door down and using a pair of long nose pliers and/or a flat blade screw driver, set the hook end of the door torsion springs onto the extruded tab on each handle bracket. See Figure 2.
15. Re-install the wheels onto the height adjuster axles using the **new** hardware supplied.
16. Re-install the upper and lower handle assembly onto the handle brackets using the hardware saved in Step 5.
17. Proceed to Step 18 on Page 3 to check the existing bagger fit with the new rear door and if a new frame and bag are required.

18. If after installing the 753-05922 service kit, your existing bagger frame does not allow the new rear door to seat properly on the bagger frame, a new frame and bag will be required.

19. Refer to Figure 3. If your bagger does not allow the new rear door to seat onto the bagger as shown in Figure 3, order a new frame and bag, see **New Frame and Bag Option** below.



New Frame and Bag Option

If your existing bagger frame is a 747-0995 / 747-0995A or similar configuration, order the new frame 747-04080 and a new bag. See Figure 4.

(See new bag options below)

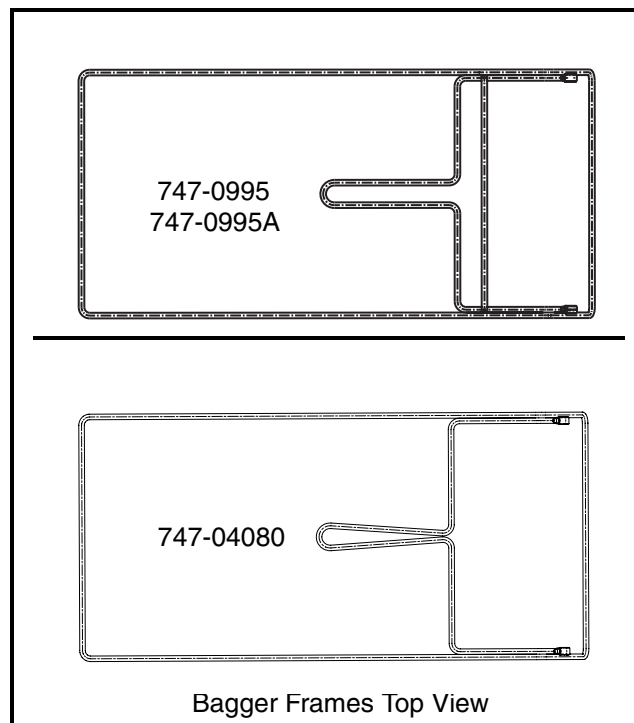

FIGURE 4

New Bagger Frame: 747-04080A-0637

New Bag: 664-04007A (No Logo)
664-04011 (Troy-Bilt Logo)
664-04012 (Yellow Sprig Logo Only)
664-04027 (YardMan Logo)