



Service Advisory

TRACTORS

W-140

Models Affected: LT 942G (13AX605G790)

Serial Number Range Affected: November 1, 2005 (“...K015...”) through July 5, 2006 (“...G056...”)

Date: **July 12, 2006**

Subject: **ANCHOR POINT FAILURE ON DECK**

PURPOSE: To provide a stronger anchoring point for the deck belt idler spring.

Parts Required For Repair:
 Qty. (1) **738-0560** Shoulder Bolt.
 Qty. (1) **736-3090** Flat Washer.
 Qty. (1) **712-04064** Flange Lock Nut.

ACTION REQUIRED:

1. Place tractor on a level surface. set parking brake and remove key from the ignition switch.
2. Remove deck from the tractor. Refer to operators manual for deck removal.
3. Locate the spring anchor on the front left side of deck as shown in FIGURE 1. The original anchor consist of a 1/4” self tapping screw (710-0778) with a spacer sleeve (750-0566A) over the screw.
4. Remove the spring from the anchor screw and sleeve using a spring puller tool if anchor screw is still attached.
5. If anchor screw is still attached remove and discard 1/4” self tapping screw and spacer sleeve.
6. Use a 1/4” drill bit and drill to enlarge the hole that the 1/4” self tapping screw was removed or missing from.
7. Check the under side of the deck. It may be necessary to remove the deck extrusion material from around the hole by grinding. The surface at the mounting hole needs to flat on both top and bottom of the deck.
8. Install shoulder screw (738-0560) from the top with the flat washer (736-3090) and flange lock nut (712-04064) from the underside. Tighten securely.

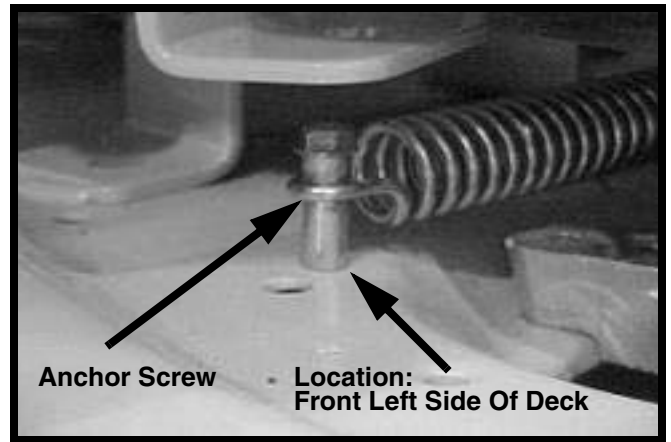
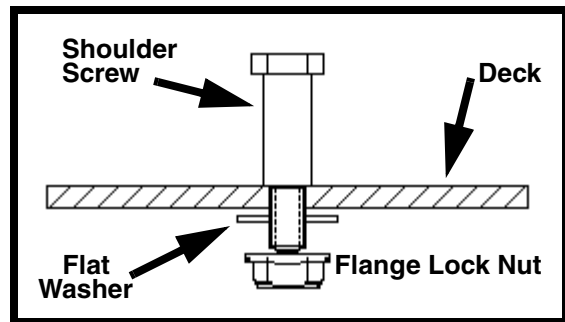

FIGURE 1

9. Attach the tension spring onto the new shoulder screw anchor point.
10. Reinstall deck and test run unit for proper operation.



Warranty: Normal warranty terms apply. Indicate Service Advisory **W-140** and **710-0778** as the original failed part on the claim. Repair time allowance is 0.5 Hrs.

SERVICE MANAGER	PARTS MANAGER	SALES MANAGER	SERVICE TECH.	SERVICE TECH.

Circulate and Initial