



Service Kit 753-06327

Date: May 25, 2010

Subject: Service Replacement for the
684-0031 700 Series Track Snow
Thrower Frame Assembly

Models Affected: 700 Series Track Model Snow
Throwers 2009 Model Year
and Earlier

Read and understand these instructions thoroughly before proceeding.

PURPOSE: This service kit provides the latest production 700 Series snow thrower frame, the new engine plate and new required hardware needed when replacing the 684-0031 700 Series track snow thrower frame assembly. The 684-0031 frame assembly is no longer available.

NOTE: These materials are prepared for use by trained technicians who are experienced in the service and repair of equipment of the kind described in this publication, and are not intended for use by untrained or inexperienced individuals. Such individuals should seek the assistance of an authorized service technician or dealer.

NOTE: Save this Instruction Sheet. Refer to it when ordering replacement parts.

Service Kit Contents (See Figure 1)

ITEM NO.	PART NUMBER	QTY	DESCRIPTION
1	684-04302B-0637	1	FRAME ASM:TRACK:700:SNOW
2	790-00322C-0637	1	PLATE:ENGINE
3	735-04099	4	PLUG:3/8" DIAMETER x 3/32"
4	736-0320	1	WASHER:FLAT: .38" x 1.38" x .125"
5	*	1	THIS INSTRUCTION SHEET

* - Not Available Separately

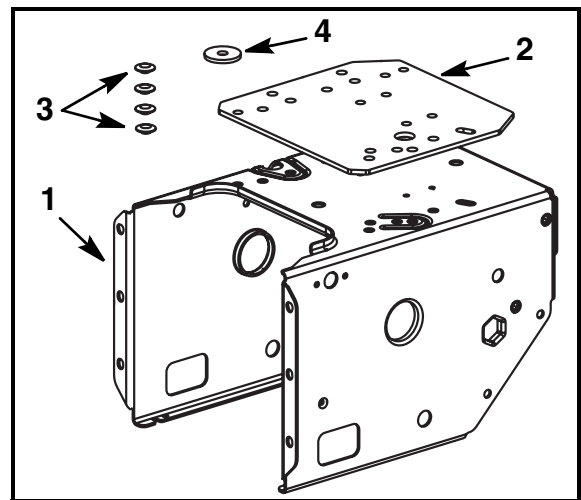

FIGURE 1

General Instructions:

1. The Engine Plate, Item 2, must be set on top of the new Frame Assembly, Item 1, with the holes in the plate aligned with the holes in the frame assembly prior to installing the engine onto the engine plate/frame.

2. Refer to Figure 2 to determine the correct engine mounting holes to use dependent on engine brand and displacement (cc value).

ENGINE MOUNTING HOLE DIAGRAM

ENGINE MOUNTING HOLE/PLUG INSTALLATION CHART

ENGINE	HOLES	HOLES TO BE PLUGGED
MTD/TEC: 179/195/208 CC	A1, A2, A3, A4	C2, A5, C1
TEC: 318-358 CC ##	B1, B2, B3, B4	A1, C2, A5, A2
BRIGGS: 206-250 CC	A5, A2, A3, A4	A1, C2

- Washer 736--0320, Item 4, is to be assembled to the inside of the frame at "B3" when mounting Tecumseh 318-358 cc engines.

Torque engine bolts 710-0502A to 325 - 450 In.-Lbs.**

(** Existing hardware - not supplied in kit)

FIGURE 2