

GENERAL PURPOSE ENGINE

GC160LA

PARTS CATALOGUE

1

FOREWORD INDEX

1

ENGINE GROUP

2

PART NUMBER INDEX

3

PART NAME INDEX

4

Instruction for use of parts catalogue

- **This parts catalogue was prepared based on the latest information available as of October 11, 2006.**
- See the parts catalogue news for any revision that is made after October 11, 2006.
- **Always specify the part number when ordering a part.**
- Check the model, type, serial numbers, color, maker, and the size as needed before ordering a part.
- Note that the illustrations (part drawings) can differ from the actual parts in shape. They are given just to help you to refer to the parts.
- **When modifications or additions to this parts catalogue are made, a revised edition will be issued at an appropriate time, with successively progressing revision numbers on the cover. We recommend obtaining such revisions in order to keep your parts catalogue up-to-date at all times. To check whether a parts catalogue revision has been issued, please contact your Honda distributor.**

Initial version issue date **October 11, 2006**
Honda Motor Co., Ltd.

CONTENTS

	Page	Address No.	
● Instruction for use of parts catalogue	1	B 1	1
● How to refer to the part information	2	B 2	
● Part catalogue structure	3	B 3	
● When the parts were revised	4	B 4	
● Abbreviations used in the parts catalogue	4	B 4	
● How to check the part block and serial numbers	5	B 5	
● Models, parts catalogue codes and applicable serial numbers	6	B 6	
● Features of each type	7	B 7	
● Fuel hose, general purpose hoses and vinyl hose	8	B 8	
● Illustrated index	9	B 9	
● ENGINE GROUP	11	C 1	2
● PART NO. INDEX	30	E 1	3
● PART NAME INDEX	32	F 1	4



How to refer to the part information

A Reference with "Illustrated index"

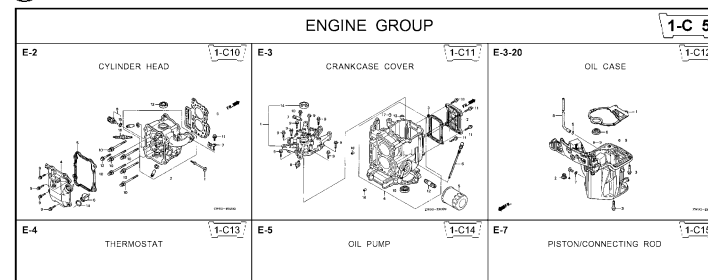

B Reference with "Part number index"

PART NO. INDEX					
Part Number	Address	Page	Rel.	Part Number	Address Page
06000				15212-ZW9-000	1-C14 3C
06316-ZW9-000	1-69	88	1	15220-ZW9-003	1-C14 3C
11000				15332-ZW9-000	1-E8 55
11300-ZW9-405	1-C11	27	1	15332-ZW9-A30	1-E11 5E
11300-ZW9-406	1-C11	27	1	15400-PFB-004	1-C11 27
11340-ZW9-000	1-C11	27	2	15422-ZW9-000	1-C14 3C
11342-ZW9-000	1-C11	27	3	15473-881-000	1-C14 3C
11381-ZW9-003	1-C12	28	1	15474-ZW9-000	1-C14 3C
				15611-921-000	1-C10 2E
				15655-ZW9-000	1-C11 27
				16000	
12000				16010-ZV4-005	1-D4 3E
12000-ZW9-405ZA	1-C11	27	4	16011-ZV4-005	1-D4 3E
12155-ZV4-A00	1-C13	29	1	16013-ZW9-003	1-D4 3E
12166-ZW9-000	1-C10	26	1	16016-ZW9-003	1-D4 3E
12209-GB4-681	1-C16	32	1	16016-ZW9-721	1-D4 3E
12210-ZW9-405ZA	1-C10	26	2	16023-ZW9-003	1-D4 3E
12216-ZE2-300	1-E8	55	1	16024-ZV4-650	1-D4 3E
	1-E11	58	1	16028-ZV4-650	1-D4 3E

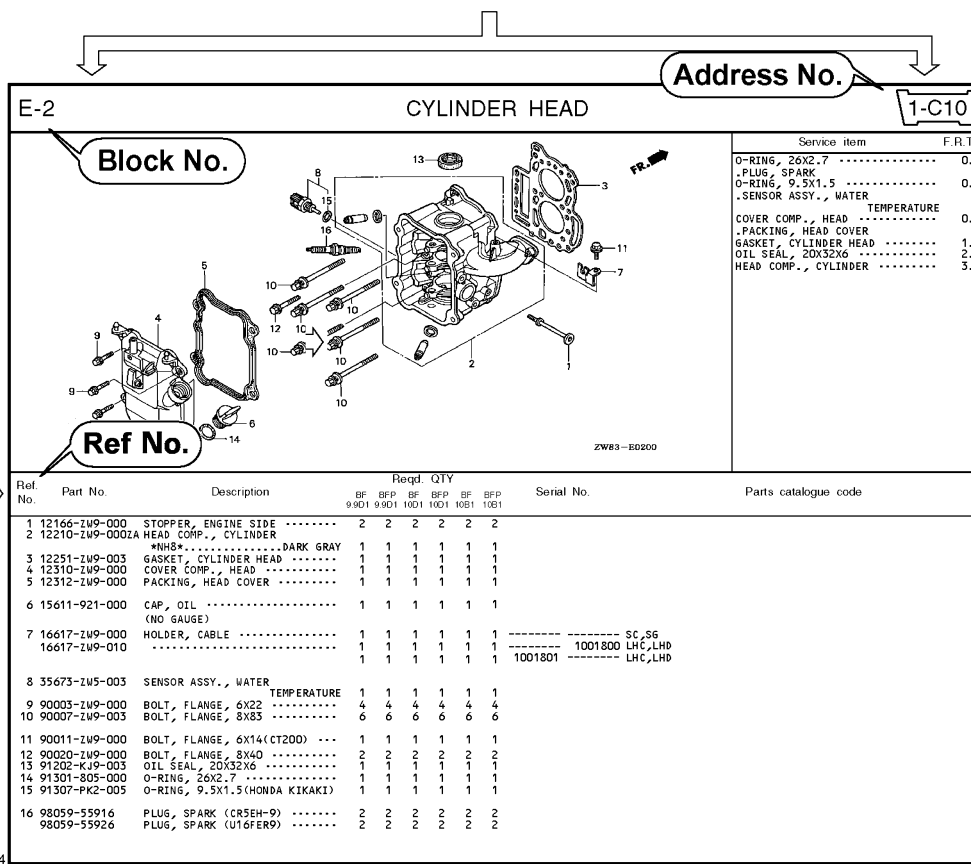

C Reference with "Part name index"

PART NAME INDEX					
Part name	Address	Page	Ref.		
[A]				BOLT,	
ABSORBER , FUEL	1-E15	62	5	BOLT,	
ARMATURE COMP.	1-D11	43	7	BOLT,	
ARM COMP. , LINK JOINT	1-G6	85	18	BOLT,	
ARM COMP. , SHIFT LINK	1-G6	85	14	BOLT,	
ARM COMP. , TILT	1-F15	79	20		
ARM , FUEL PUMP ROCKER	1-C16	32	4		
ARM , REVERSE LOCK	1-F15	79	18		
ARM , SHIFT LINK	1-F11	74	7		
ARM , STOPPER	1-D1	33	12	BOLT,	
ARM , THROTTLE REMOTE	1-F11	74	6		
ARM , VALVE ROCKER	1-C16	32	3		
[B]					
BAG , TOOL , 160MM	1-G5	84	10		
BAND	1-G6	86	37		
BAND B1 , WIRE	1-F6	69	1		
BAND , CORD	1-F3	67	18	BOLT,	
BAND , TUBE CLIP , 11MM	1-E15	63	20		
BAND , TUBE CLIP , 12.5MM	1-E15	63	19	BOLT,	

Page No.

2006.09.20 E

Part catalogue structure

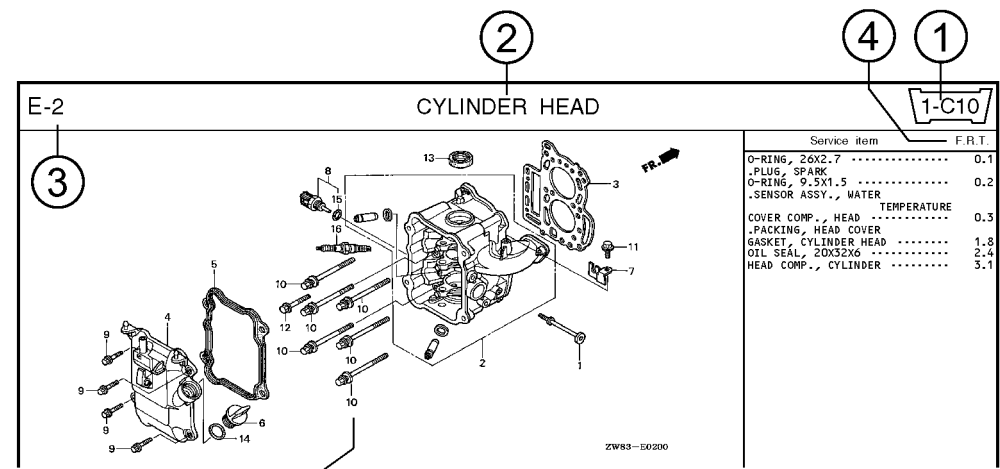

Ref. No.	Part No.	Description	Reqd. QTY						Serial No.	Parts catalogue code
			BF 9/901	BFP 9/901	BF 1001	BFP 1001	BF 1081	BFP 1081		
1	12166-zw9-000	STOPPER, ENGINE SIDE	2	2	2	2	2	2		
2	12210-zw9-000ZA	HEAD COMP., CYLINDER *NH8*	1	1	1	1	1	1		
3	12251-zw9-003	GASKET, CYLINDER HEAD	1	1	1	1	1	1		
4	12310-zw9-000	COVER COMP., HEAD	1	1	1	1	1	1		
5	12312-zw9-000	PACKING, HEAD COVER	1	1	1	1	1	1		
6	15611-921-000	CAP, OIL (NO GAUGE)	1	1	1	1	1	1		
7	16617-zw9-000	HOLDER, CABLE	1	1	1	1	1	1	SC,S6	
	16617-zw9-010		1	1	1	1	1	1	1001800 LHC,LHD	

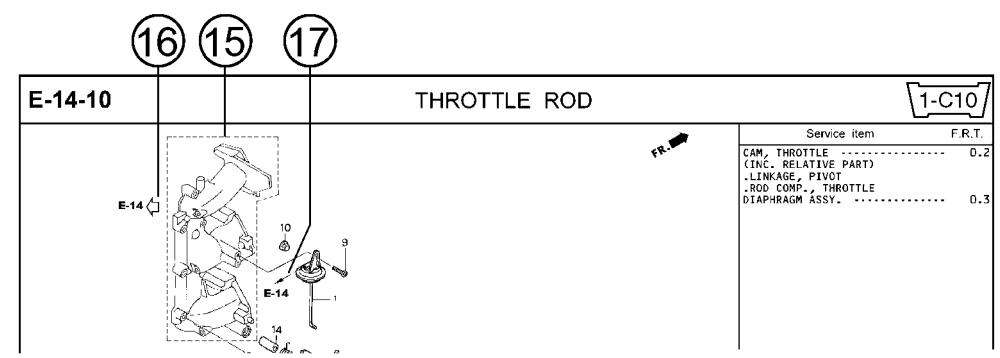

- ① **Address number**
 - Address No. is provided (in place of the page No.) to help you refer to the part with the part No. or part name.
- ② **Block title** ③ **Block number**
- ④ **Service item/Flat rate time**
- ⑤ **Reference number**
 - Title number marked with the parenthesis or parentheses indicates that it continues from the previous page.
- ⑥ **Part number** ⑦ **Honda color code**
- ⑧ **Description**
- ⑨ **Assemblies**
 - Sections framed with broken lines in the exploded view drawings are available as complete assemblies. (Their individual parts can also be obtained.)
- ⑩ **Color description**
- ⑪ **Note**
 - Notes are shown with the parentheses in the part name column.
- ⑫ **Required quantity**
 - Required QTY shown in the parenthesis or parentheses indicates the optional part.
 - Required QTY marked with "N" Indicates the optional part that should be selected as needed.
 - Required QTY indicates the number of the part used in the block.
- ⑬ **Serial number**
- ⑭ **Type**
 - When the type column is blank, it indicates that the part is applicable to all types.
 - As the type of the actual unit may differ from the "parts catalogue, type" please refer to "Models, types and applicable serial numbers" for confirmation.
- ⑮ **[Dotted box]**
 - Parts enclosed within a dotted line [] are covered in a different block.
- ⑯ **[Hollow arrow]**
 - A hollow arrow [] indicates the block No. for the parts enclosed within a dotted line [] .
- ⑰ **[Solid arrow]**
 - A solid arrow [] indicates the block No. the part in question is connected to.

When the parts were revised

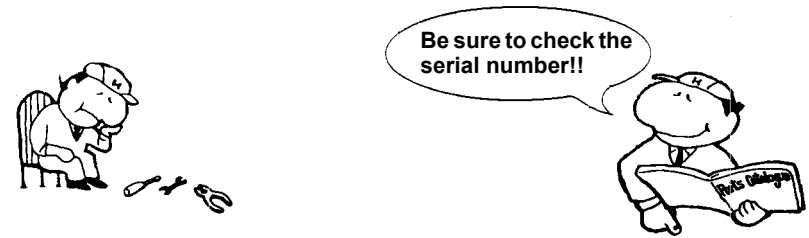

Ref. No.	Part No.	Description	Reqd. QTY						Serial No.
			BF 99D1	BFP 9.9D1	BF 10D1	BFP 10D1	BF 10B1	BFP 10B1	
1	12166-ZW9-000	STOPPER, ENGINE SIDE	2	2	2	2	2	2	
2	12210-ZW9-000ZA	HEAD COMP., CYLINDER *NH8*.....DARK GRAY	1	1	1	1	1	1	
3	12251-ZW9-003	GASKET, CYLINDER HEAD	1	1	1	1	1	1	
4	12310-ZW9-000	COVER COMP., HEAD	1	1	1	1	1	1	
5	12312-ZW9-000	PACKING, HEAD COVER	1	1	1	1	1	1	
6	15611-921-000	CAP, OIL (NO GAUGE)	1	1	1	1	1	1	
7	16617-ZW9-000	HOLDER, CABLE (###).....	1	1	1	1	1	1	
	16617-ZW9-010	1	1	1	1	1	1	

The number has been used from the initial model without revision. When shown at the left side, it is applicable to the models of No.1001801 and the subsequent numbers. When shown at the right side, it is applicable to the models up to No.1001800.

• The parts listed with "###" at the end of the parts name have limited supply period (parts not for sale).

Abbreviations used in the parts catalogue

• The following abbreviations are used in the parts name column.

- A Ampere
- A.C. Alternating current
- ASSY. Assembly
- AT. Automatic transmission
- C.D.I. Capacitive discharge ignition
- COMP. ... Complete
- D.C. Direct current
- EX. Exhaust
- G.F.C.I ... Ground fault circuit interruptor
- HEX. Hexagonal
- H.S.T. Hydrostatic transmission
- FR.Front
- IN.Inlet
- L (100L) .Link (100 Links)
- L.Left
- MMMillimeter
- MT.Manual Transmission
- P.T.O.Power take off
- R.Right
- RR.Rear
- STD.Standard
- T (22T) ...Tooth (22 Teeth)
- VVolt
- WWatt

How to check the part block and serial numbers

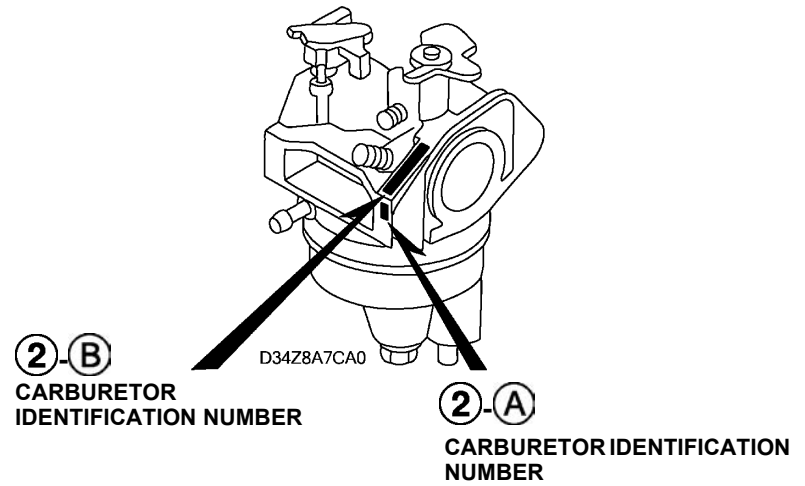
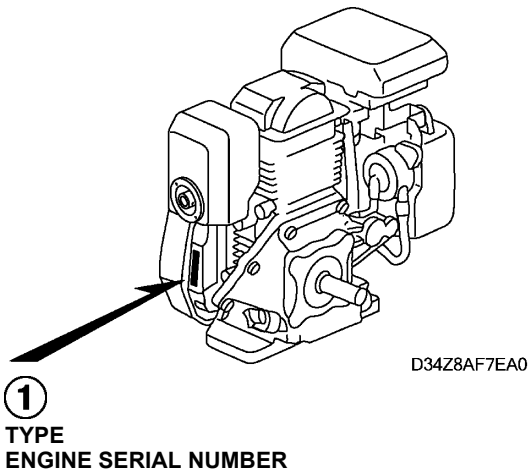
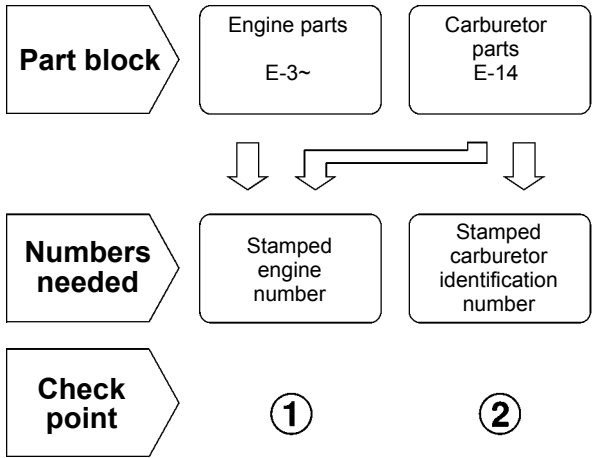

Models, parts catalogue codes and applicable serial numbers

- Models, parts catalogue codes and applicable serial Nos. given in this parts catalogue can be identified as follows.

Model	Type	Parts catalogue type	Applicable engine serial No.	Applicable carburetor identification No.
GC160LA	DHAF	DHAF	GCAHA-1000001~	BB61J A
	MHA2	MHA2		
	PHA	PHA		
	QBC	QBC		
	QDE	QDE		
	QFC	QFC		
	QHA	QHA		
	QHAF	QHAF		
	QHAJ	QHAJ		
	QHA1	QHA1		
	QHA2	QHA2		
	QHC	QHC		
	VHA	VHA		
VXA	VXA			

* Of carburetor identification numbers, only the portions underlined in the example below are used for registration.

BB 61J A KC ㊦
 (A) (B)

Features of each type

• See the following table for the features of each type. (Items in brackets are optional)

Specifications		Model	GC160LA												
		Type	MHA2	QBC	QDE	QFC	QHA	QHAF	DHAF	QHAJ	QHA1	QHA2	QHC	PHA	VHA
Crankshaft	19.05mm Ø X 48mm Straight	●													
	19.05mm Ø X 58.5mm Straight		●	●	●	●	●		●	●	●	●			
	22.2mm Ø Straight							●							
	3/4" Thread												●		
	Tapered													●	●
Spark arrester		(●)	(●)	(●)	(●)	(●)	(●)	(●)	●	(●)	(●)	(●)	(●)	●	●
Oil alert															●
Oil level switch															●
Fuel tank		●	●	●	●	●	●	●		●	●	●	●	●	●
Fuel strainer		●							●		●				

Fuel hose, general purpose hoses and vinyl hose

- The standard part fuel hose, general purpose hose and vinyl hose may be substituted by the coiled bulk part.
- When ordering the standard part fuel hose, general purpose hose and vinyl hose use the bulk part number written in the parts catalog in brackets () underneath the part name.
- When exchanging the hose, cut and use at the specified length as mentioned in the part name.
(For the method of cutting the bulk part, and method of filling out orders etc., please refer to the instructions issued with the bulk part.)

Bulk part number of fuel hose, general purpose hose and vinyl hose.

Example: 9 5 0 0 1 - 7 5 0 0 1 - 5 0 M

Bulk part number:
Refers to the bulk part.

Marking code (fuel hose and general purpose hose)

Change code (Vinyl hose)

Indicates number mark or change sequence, however, the code for the bulk part must be strictly 0 (zero).

Types of code:

- | | | | | | |
|-------------|--|----------------|--|--------------|---|
| • Fuel hose | 2: Red outside braid
(3 mm inside dia. only) | • General hose | 1: Ash gray
2: Ash gray
3: Black
5: Black | • Vinyl hose | 1: Clear
2: Black
3: Light red
6: Light red
7: Pale black |
| | 5: Black inside braid | | | | |
| | 3: Red (3 mm inside dia. only) | | | | |
| | 4: Ash gray with red stripe
(3 mm inside dia. only) | | | | |
| | 6: Black | | | | |

Lengths:

- 001: 1 m (standard)
003: 3 m
008: 8 m } Application or specification of some parts is not settled.

I.D code: (fuel hose and general purpose hose)

- | | | | | |
|------------|--------------------|--------------------|-----------------------------|-----------------------------|
| 30: 3.0 mm | 50: 5.0 mm | 70: 7.0 mm | 11: 11 mm | 12: 12 (outside dia. 17) mm |
| 35: 3.5 mm | 55: 5.3 mm, 5.5 mm | 75: 7.3 mm, 7.5 mm | 91: 12 (outside dia. 15) mm | 14: 14 mm |
| 45: 4.5 mm | 65: 6.5 mm | 80: 8.0 mm | 92: 12 (outside dia. 16) mm | 17: 17 mm |

ID./OD. code: (vinyl hose)

- | | | | | |
|-------------------------|--------------------------|---------------------------|---------------------------|---------------------------|
| 01: ID. 2.9, OD. 6.8 mm | 12: ID. 5.0, OD. 7.0 mm | 21: ID. 8.0, OD. 9.0 mm | 37: ID. 11.0, OD. 15.0 mm | 50: ID. 16.0, OD. 19.0 mm |
| 03: ID. 3.0, OD. 6.0 mm | 10: ID. 5.0, OD. 8.0 mm | 23: ID. 8.0, OD. 12.0 mm | 38: ID. 12.0, OD. 13.0 mm | 55: ID. 17.5, OD. 20.5 mm |
| 05: ID. 3.5, OD. 6.5 mm | 11: ID. 5.0, OD. 9.0 mm | 25: ID. 9.0, OD. 11.0 mm | 39: ID. 12.0, OD. 14.0 mm | 60: ID. 22.0, OD. 27.0 mm |
| 07: ID. 4.0, OD. 7.0 mm | 14: ID. 6.0, OD. 9.0 mm | 27: ID. 9.0, OD. 13.0 mm | 40: ID. 12.0, OD. 16.0 mm | |
| 08: ID. 4.5, OD. 6.5 mm | 17: ID. 7.0, OD. 9.0 mm | 33: ID. 10.0, OD. 14.0 mm | 43: ID. 13.0, OD. 15.0 mm | |
| 09: ID. 4.5, OD. 8.0 mm | 19: ID. 7.0, OD. 11.0 mm | 36: ID. 11.0, OD. 13.0 mm | 45: ID. 14.0, OD. 18.0 mm | |

Hose type:

- 1: Fuel hose
3: Vinyl hose
5: General hose

⊙ **CAUTION: It is DANGEROUS to confuse the fuel hose with the general purpose hose or vinyl hose.**

Never use a general purpose hose or vinyl hose in place of a fuel hose or vice versa. Always use the correct bulk part in the parts catalogue, according to the service manual or the instructions issued with the bulk part.

ENGINE GROUP

B 9

E-3

CYLINDER BARREL

C 1

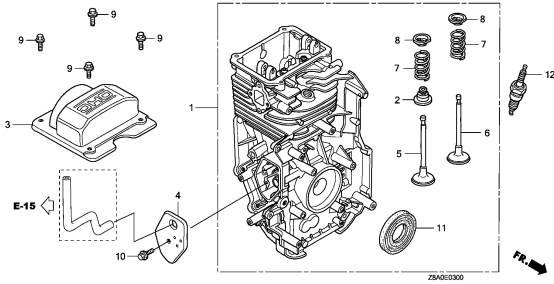

E-6

CRANKCASE COVER

C 2

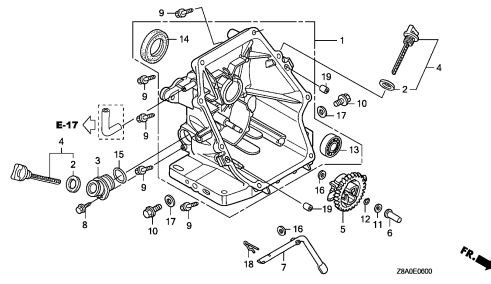

E-7

CRANKSHAFT

C 3

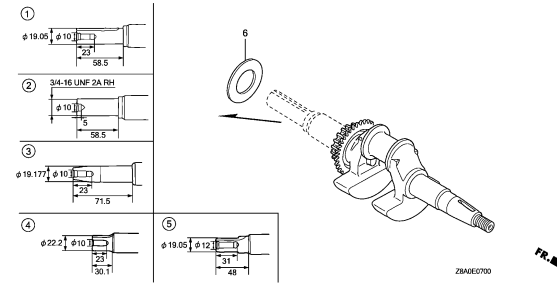

E-8

PISTON/CONNECTING ROD

C 4

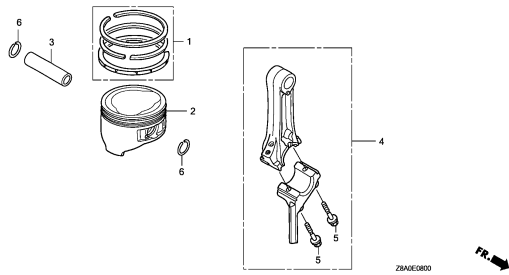

E-9

CAMSHAFT

C 5

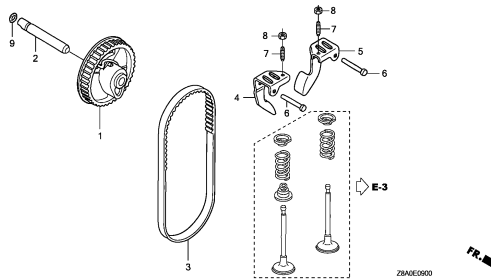

E-11

RECOIL STARTER

C 6

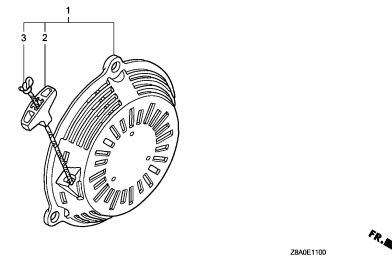

E-12

FAN COVER

C 7

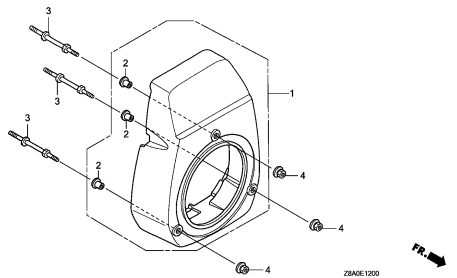

E-14

CARBURETOR

C 8

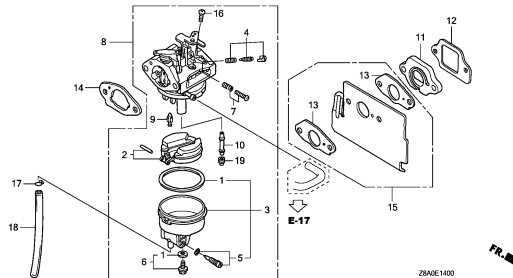

E-15

AIR CLEANER

C 9

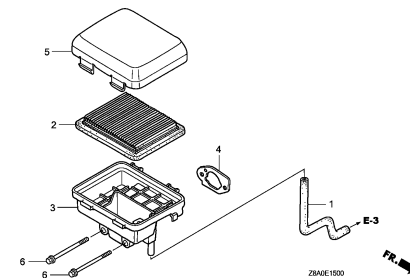

2

ENGINE GROUP

B10

E-16

MUFFLER

C10

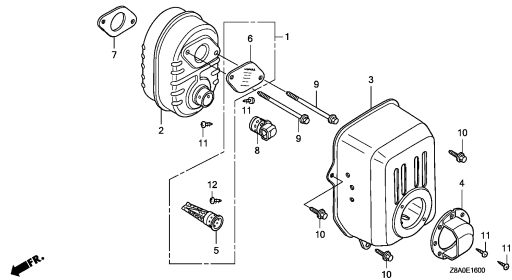

E-17

FUEL TANK/FUEL PUMP

C11

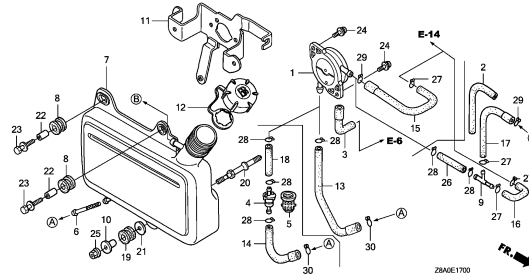

E-19

FLYWHEEL/IGNITION COIL

C13

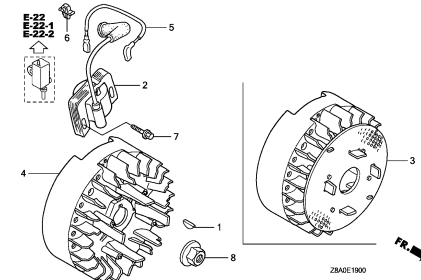

E-19-10

OIL ALERT/OIL LEVEL SWITCH

C14

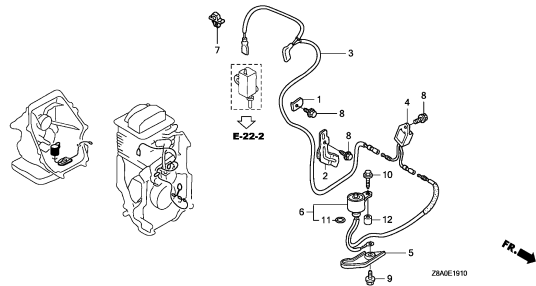

E-22

CONTROL(1)

C15

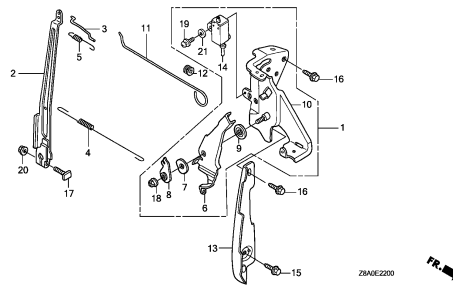

E-22-1

CONTROL(2)

C16

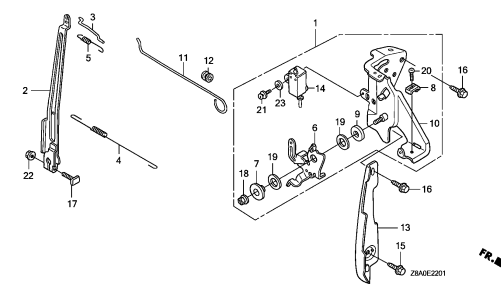

E-22-2

CONTROL(3)

D 1

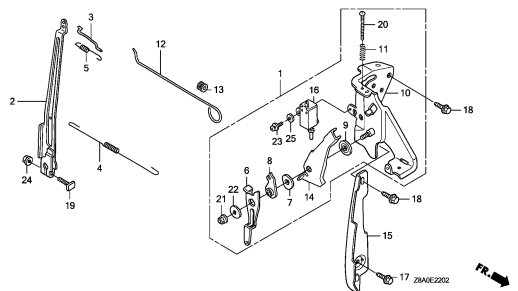

E-22-3

CONTROL(4)

D 2

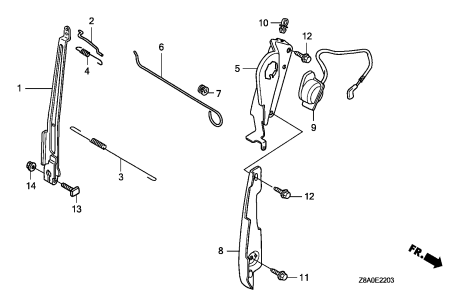

E-28

LABEL

D 3

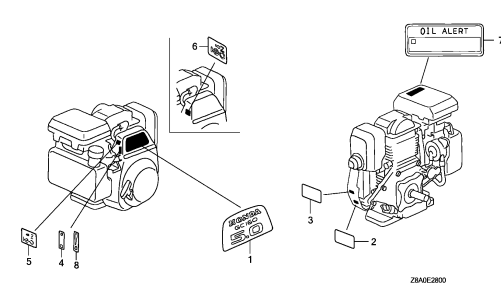

2

E-3

CYLINDER BARREL

C 1

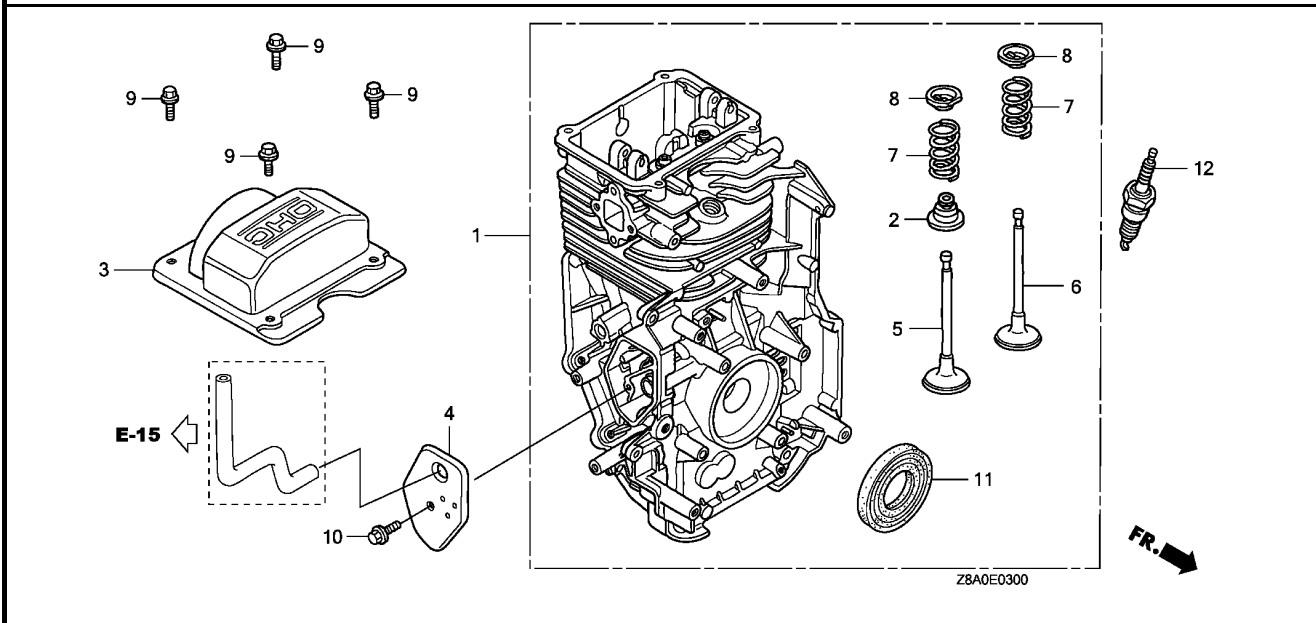

Service item	F.R.T.

Ref. No.	Part No.	Description	Reqd. QTY		Serial No.	Parts catalogue code
			GC	LA		
1	12000-ZL8-425	BARREL ASSY., CYLINDER	1			
2	12209-ZM0-003	SEAL, VALVE STEM	1			
3	12310-Z0J-000	COVER COMP., CYLINDER HEAD	1			
4	12355-ZL8-000	COVER COMP., BREATHER	1			
5	14711-Z0J-000	VALVE, IN.	1			
6	14721-ZL8-000	VALVE, EX.	1			
7	14751-ZL8-000	SPRING, VALVE	2			
8	14771-Z0J-000	RETAINER, VALVE SPRING	2			
9	90013-883-000	BOLT, FLANGE, 6X12(CT200)	4			
10	90014-952-000	BOLT, FLANGE, 6X14(CT200)	1			
11	91201-ZL8-003	OIL SEAL, 25.4X62X6	1			
12	98079-56846	PLUG, SPARK (BPR6ES)(NGK)	1			

2

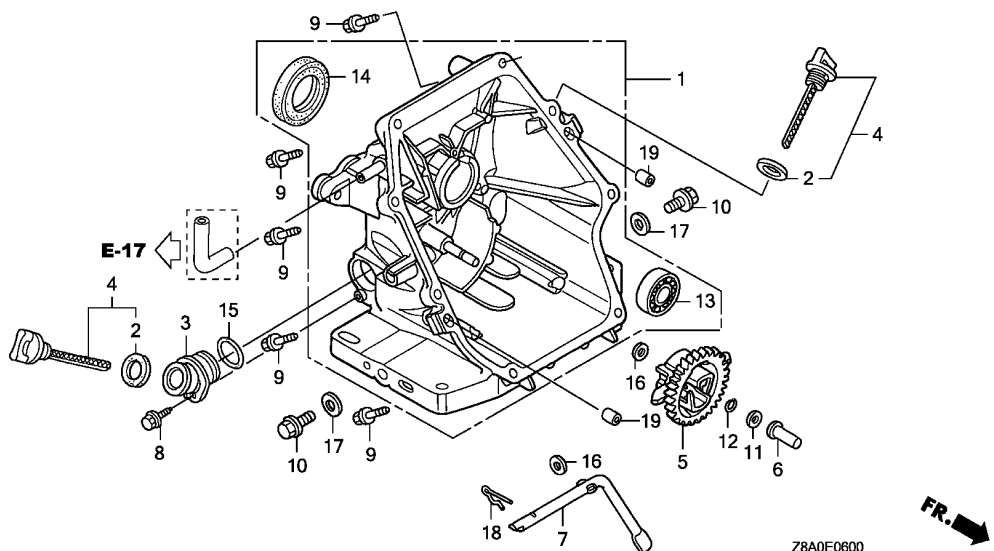

Service item F.R.T.

Ref. No.	Part No.	Description	Reqd. QTY		Serial No.	Parts catalogue code
			GC 160 LA			
1	11300-ZL8-405	COVER ASSY., CRANKCASE	1		PHA,QBC,QFC,VHA	
	11300-ZL8-406	1		VXA	
	11300-ZL8-409	1		DHAF,MHA2,QHA,QHAF,QHAJ,QHA1,QHA2,QHC	
	11300-Z0J-405	1		QDE	
2	15625-Z2L-801	PACKING, OIL FILLER CAP	1		DHAF,MHA2,PHA,QBC,QFC,QHA,QHAF,QHAJ,QHA1,QHA2,QHC,VHA,VXA	
		2		QDE	
3	15631-ZL8-000	EXTENSION, OIL FILLER	1		QDE	
4	15650-Z2L-801	GAUGE ASSY., OIL LEVEL	1		DHAF,MHA2,PHA,QBC,QFC,QHA,QHAF,QHAJ,QHA1,QHA2,QHC,VHA,VXA	
		2		QDE	
5	16510-ZL8-000	GOVERNOR ASSY.	1			
6	16531-ZE1-000	SLIDER, GOVERNOR	1			
7	16541-ZL8-000	SHAFT, GOVERNOR ARM	1			
8	90013-ZL8-000	BOLT, FLANGE, 6X14(CT200)	1		QDE	
9	90121-952-000	BOLT, FLANGE, 6X25(CT200)	8			
10	90131-883-000	BOLT, DRAIN PLUG, 12X15	2			
11	90451-ZE1-000	WASHER, THRUST, 6MM	1			
12	90602-ZE1-000	CLIP, GOVERNOR HOLDER	1			
13	91001-ZL8-003	BEARING, RADIAL BALL, 62/28	1		PHA,QBC,QFC,VHA,VXA	
14	91202-ZL8-003	OIL SEAL, 28X41.25X6	1			
15	91301-ZE9-003	O-RING, 22.5X2.2	1		QDE	
16	94101-06800	WASHER, PLAIN, 6MM	2			
17	94109-12000	WASHER, DRAIN PLUG, 12MM	2			
18	94251-08000	PIN, LOCK, 8MM	1			
19	94301-08200	DOWEL PIN, 8X20	2			

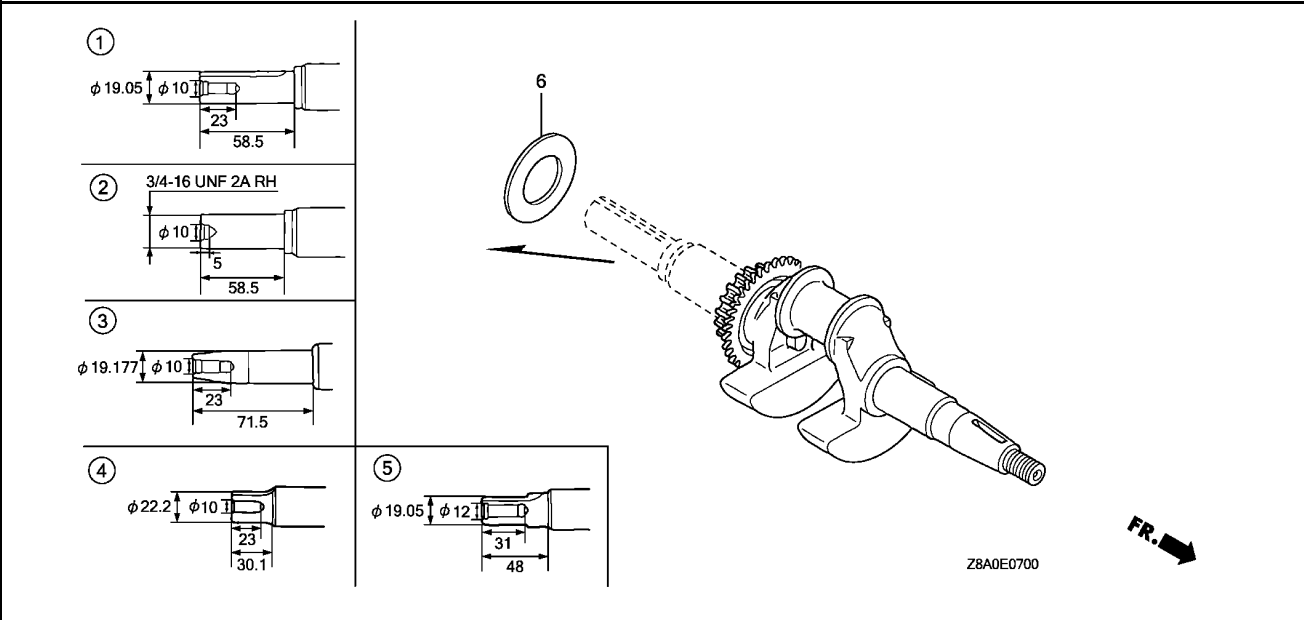

Service item	F.R.T.
--------------	--------

Ref. No.	Part No.	Description	Reqd. QTY	Serial No.	Parts catalogue code
			GC 160 LA		
1	13310-ZL8-600	CRANKSHAFT COMP.	1	-----	QBC,QDE,QFC,QHA,QHAF,QHAJ,QHA1,QHA2,QHC
2	13310-ZL8-650	CRANKSHAFT COMP.	1	-----	PHA
3	13310-ZL8-671	CRANKSHAFT COMP.	1	-----	VHA,VXA
4	13310-Z0J-651	CRANKSHAFT COMP.	1	-----	DHAF
5	13310-Z0J-660	CRANKSHAFT COMP.	1	-----	MHA2
6	90402-ZL8-000	WASHER, THRUST	1		



E-8

PISTON/CONNECTING ROD

C 4

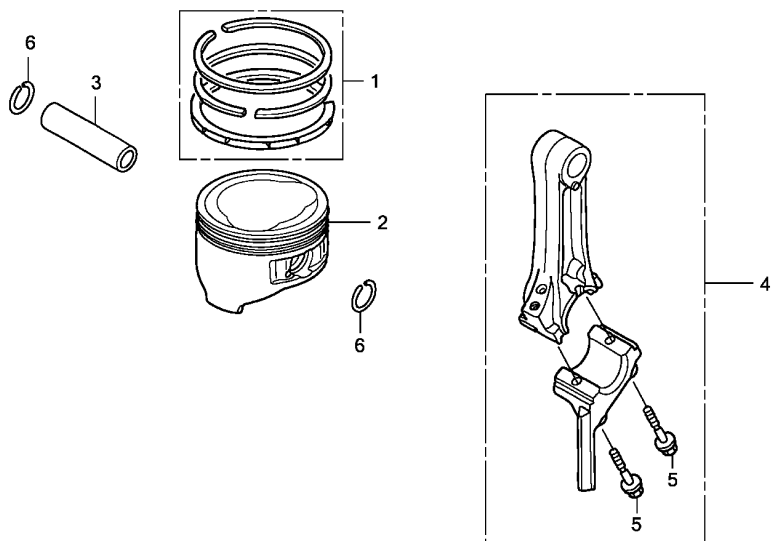

Z8A0E0800



Service item F.R.T.

2

Ref. No.	Part No.	Description	Reqd. QTY		Serial No.	Parts catalogue code
			GC 160 LA			
1	13010-Z0L-014	RING SET, PISTON (STD.) (TEIKOKU)		1		
2	13101-Z2A-010	PISTON		1		
3	13111-ZE0-000	PIN, PISTON		1		
4	13200-Z0J-000	ROD ASSY., CONNECTING		1		
5	90001-ZE1-000	BOLT, CONNECTING ROD		2		
6	90551-ZE0-000	CLIP, PISTON PIN, 13MM		2		

E-9

CAMSHAFT

C 5

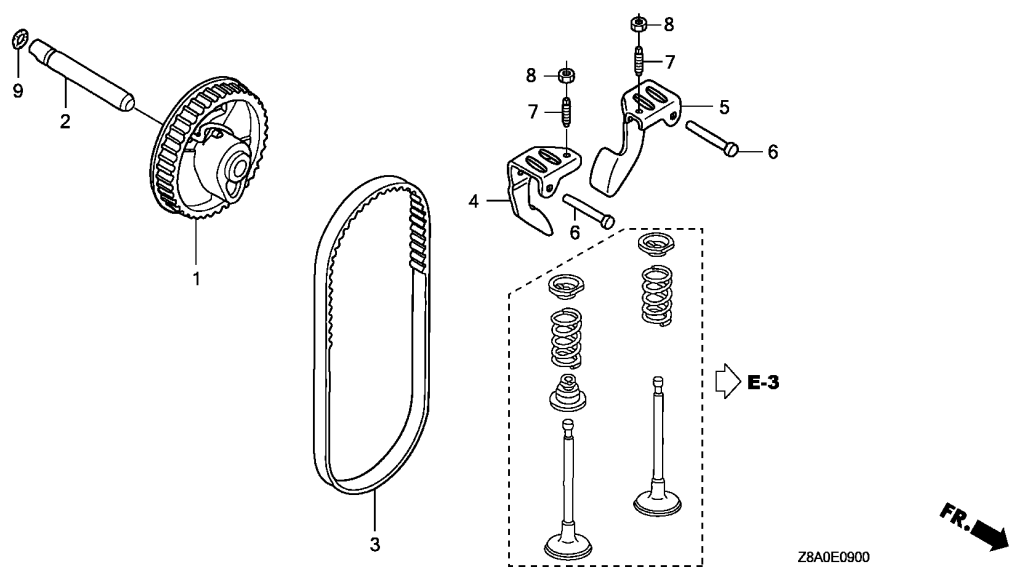

Service item F.R.T.

Ref. No.	Part No.	Description	Reqd. QTY		Serial No.	Parts catalogue code
			GC	LA		
1	14320-ZL8-010	PULLEY COMP., CAMSHAFT	1			
2	14324-ZL8-000	SHAFT, CAM PULLEY	1			
3	14400-ZOJ-014	BELT, TIMING (84HU7 G-200)	1			
4	14431-ZOJ-000	ARM, IN. VALVE ROCKER	1			
5	14441-ZOJ-000	ARM, EX. VALVE ROCKER	1			
6	14461-ZL8-000	SHAFT, ROCKER ARM	2			
7	90012-333-000	SCREW, TAPPET ADJUSTING	2			
8	90206-001-000	NUT, TAPPET ADJUSTING	2			
9	91301-ZM0-V31	O-RING, 6.8X1.9(ARAI)	1			

2

Service item F.R.T.

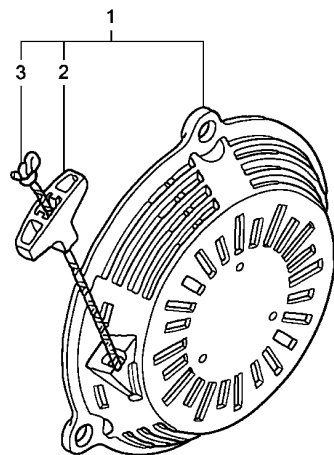

Z8A0E1100



2

Ref. No.	Part No.	Description	Reqd. QTY		Serial No.	Parts catalogue code
			GC	LA		
1	28400-ZL8-023ZA	STARTER ASSY., RECOIL	1			
	NH1BLACK	1	-----	-----	DHAF,MHA2,PHA,QBC,QDE,QFC,QHA,QHAF,QHA1,QHA2,QHC,VHA,VXA
	28400-ZL8-023ZC	*R280*.....POWER RED	1	-----	-----	DHAF
	28400-ZM0-023ZA	*NH1*.....BLACK	1	-----	-----	QHAI
2	28461-ZL8-003	GRIP, STARTER	1			
3	28462-ZL8-003	ROPE, RECOIL STARTER	1			

Service item

F.R.T.

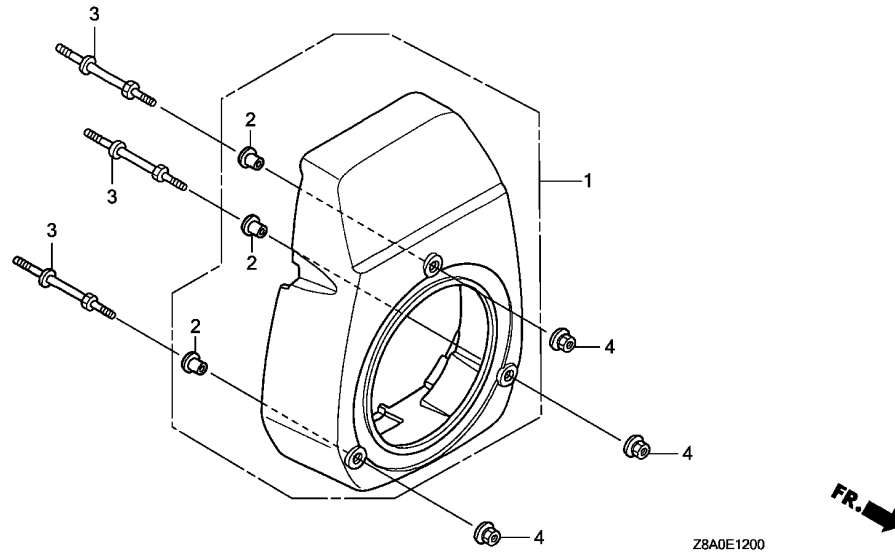

Ref. No.	Part No.	Description	Reqd. QTY		Serial No.	Parts catalogue code
			GC	LA		
1	19611-ZL8-000ZA	COVER, FAN				
		NH1.....BLACK	1			
	19611-ZL8-000ZC	*R280*.....POWER RED	1		----- DHAF	
2	19619-ZL8-300	COLLAR, FAN COVER	3			
3	90043-ZL8-000	BOLT, STUD	3			
4	90201-ZM0-000	NUT, FLANGE, 6MM	3			



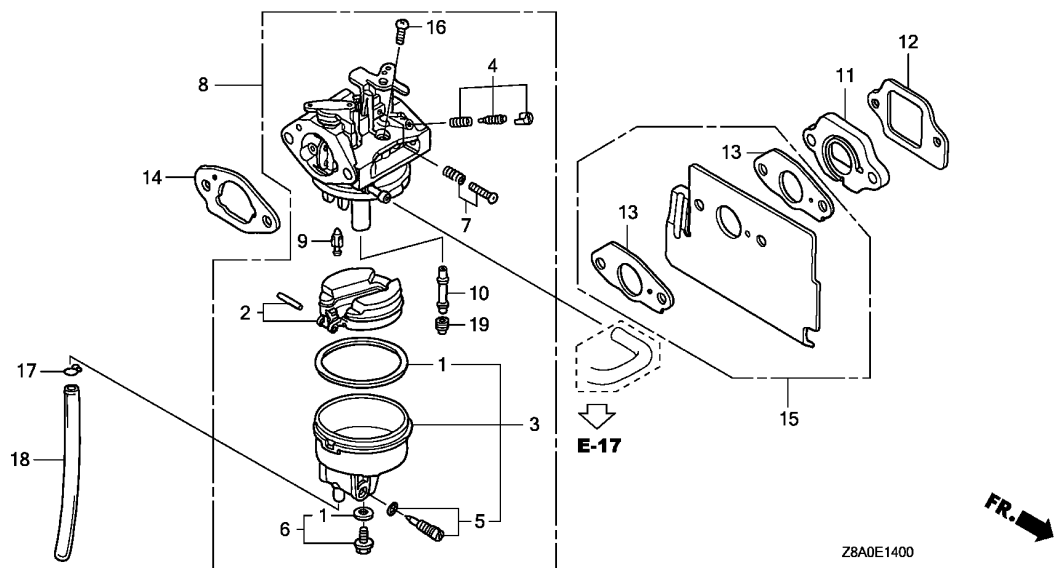

Service item F.R.T.

Ref. No.	Part No.	Description	Reqd. QTY		Serial No.	Parts catalogue code
			GC	LA		
1	16010-883-015	PACKING SET	1			
2	16013-ZL1-003	FLOAT SET	1			
3	16015-ZL8-003	CHAMBER SET, FLOAT	1			
4	16016-ZG0-W00	SCREW SET	1			
5	16024-124-760	SCREW SET, DRAIN	1			
6	16028-ZE0-005	SCREW SET	1			
7	16029-ZG0-901	SCREW SET (THROTTLE STOP) ...	1			
8	16100-Z0J-003	CARBURETOR ASSY. (BB61J A) ..	1			
9	16155-ZL8-013	VALVE COMP., FLOAT	1			
10	16166-ZL8-003	NOZZLE, MAIN	1			
11	16211-ZL8-000	INSULATOR, CARBURETOR	1			
12	16212-ZL8-000	PACKING, INSULATOR	1			
13	16221-883-800	PACKING, CARBURETOR	2			
14	16228-ZL8-000	PACKING, CARBURETOR	1			
15	19650-ZL8-000	GUIDE COMP., AIR	1			
16	93500-05006-1H	SCREW, PAN, 5X6	1			
17	95002-02650	CLIP, TUBE (B6.5)	1			
18	95003-07015-31	TUBE, VINYL, 4X7X150	1			
		(95003-07001-60M)	1			
19	99101-124-0600	JET, MAIN, #60	(1)			
	99101-124-0620	JET, MAIN, #62	(1)			
	99101-124-0650	JET, MAIN, #65	1			

Service item F.R.T.

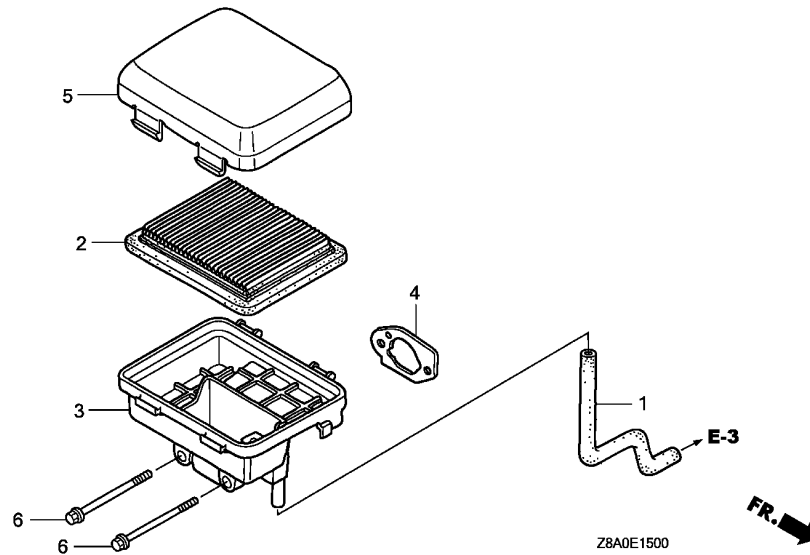

Ref. No.	Part No.	Description	Reqd. QTY		Serial No.	Parts catalogue code
			GC	LA		
1	15721-ZL8-000	TUBE, BREATHER	1			
2	17211-ZL8-023	ELEMENT, AIR CLEANER	1			
3	17220-ZL8-000	CASE COMP., AIR CLEANER	1			
4	17228-ZL8-000	PACKING, AIR CLEANER	1			
5	17231-Z0J-020	COVER, AIR CLEANER	1			
6	90003-ZL8-000	BOLT, FLANGE, 6X112(CT200) ..	2			



Service item F.R.T.

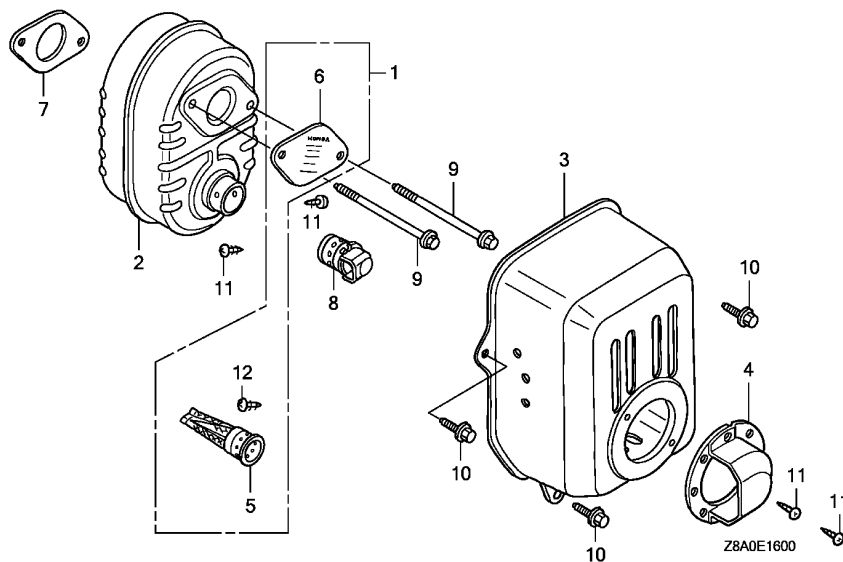

Ref. No.	Part No.	Description	Reqd. QTY		Serial No.	Parts catalogue code
			GC	160 LA		
1	06180-Z0J-000	ARRESTER KIT, SPARK	(1)			
2	18310-Z0Y-000	MUFFLER COMP.	1			
3	18321-Z0L-000	PROTECTOR, MUFFLER	1			
4	18348-ZL8-000	CAP, MUFFLER	1	-----	QDE	
5	18350-ZL8-000	ARRESTER COMP., SPARK	1	-----	QHAJ,VHA,VXA	
			(1)	-----	DHAF,MHA2,PHA,QBC,QDE,QFC,QHA,QHAF,QHA1,QHA2,QHC	
6	18356-ZL8-000	PLATE, ARRESTER NUMBER	1	-----	QHAJ,VHA,VXA	
			(1)	-----	DHAF,MHA2,PHA,QBC,QDE,QFC,QHA,QHAF,QHA1,QHA2,QHC	
7	18381-ZL8-305	GASKET, MUFFLER	(1)			
8	18430-ZL8-000	DEFLECTOR COMP., MUFFLER	1	-----	QDE	
9	90004-ZL8-000	BOLT, FLANGE, 6X79(CT200) ...	2			
10	90013-883-000	BOLT, FLANGE, 6X12(CT200) ...	3			
11	90055-ZE1-000	SCREW, TAPPING, 4X6	4	-----	QDE	
12	90055-ZE1-000	SCREW, TAPPING, 4X6	1	-----	QHAJ,VHA,VXA	
			(1)	-----	DHAF,MHA2,PHA,QBC,QDE,QFC,QHA,QHAF,QHA1,QHA2,QHC	

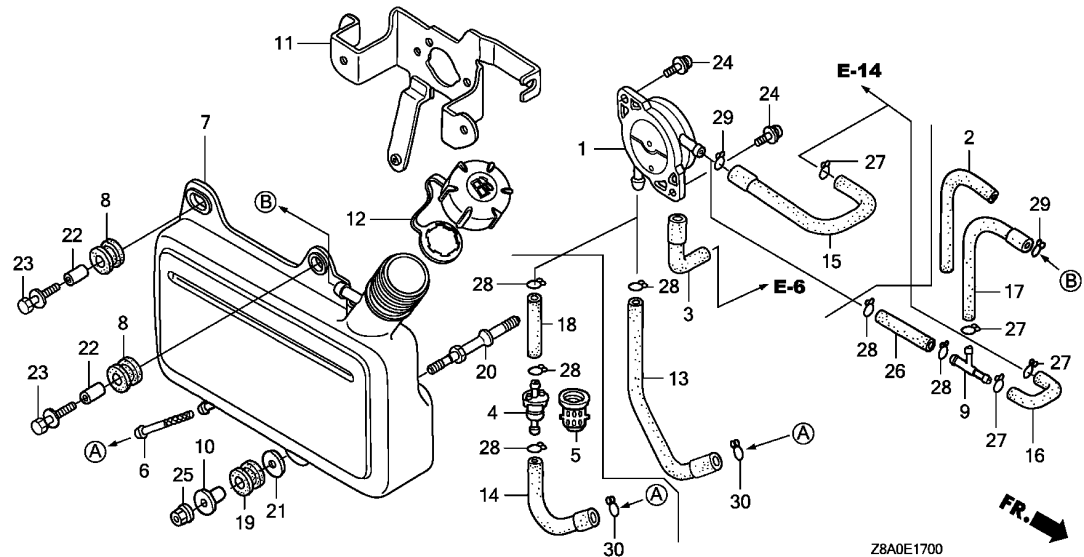

Service item

F.R.T.

Ref. No.	Part No.	Description	Reqd. QTY	Serial No.	Parts catalogue code
			GC 160 LA		
1	16700-Z0J-003	PUMP ASSY., FUEL	1		
2	16854-ZH8-000	RUBBER, SUPPORTER (107MM) ...	1	-----	MHA2,QHA2
3	16882-ZL8-000	TUBE, DIAPHRAGM	1		
4	16910-ZV4-015	STRAINER COMP., FUEL	1	-----	MHA2,QHAJ,QHA2
5	16915-ZV4-000	SUSPENSION, STRAINER	1	-----	MHA2,QHAJ,QHA2
6	16952-ZA8-800	STRAINER, FUEL	1	-----	DHAF,PHA,QBC,QDE,QFC,QHA,QHAF,QHA1,QHC,VHA,VXA
7	17511-Z0J-000	TANK, FUEL	1	-----	DHAF,PHA,QBC,QDE,QFC,QHA,QHAF,QHA1,QHC,VHA,VXA
	17511-Z0J-800	1	-----	MHA2,QHA2
8	17516-ZV0-000	RUBBER B, TANK MOUNTING	2	-----	DHAF,MHA2,PHA,QBC,QDE,QFC,QHA,QHAF,QHA1,QHA2,QHC,VHA,VXA
9	17519-ZL8-800	JOINT, FUEL TUBE	1	-----	MHA2,QHA2
10	17535-166-000	COLLAR, FR. COVER SETTING ...	1	-----	DHAF,MHA2,PHA,QBC,QDE,QFC,QHA,QHAF,QHA1,QHA2,QHC,VHA,VXA
11	17561-Z0J-000	STAY A, FUEL TANK	1		
12	17620-Z0J-800	CAP ASSY., FUEL TANK	1	-----	DHAF,MHA2,PHA,QBC,QDE,QFC,QHA,QHAF,QHA1,QHA2,QHC,VHA,VXA
13	17701-ZL8-000	TUBE, FUEL TANK	1	-----	DHAF,PHA,QBC,QDE,QFC,QHA,QHAF,QHA1,QHC,VHA,VXA
14	17701-ZL8-800	TUBE, FUEL TANK	1	-----	MHA2,QHA2
15	17702-ZL8-000	TUBE, FUEL	1	-----	DHAF,PHA,QBC,QDE,QFC,QHA,QHAF,QHAJ,QHA1,QHC,VHA,VXA
16	17702-ZL8-800	TUBE, FUEL	1	-----	MHA2,QHA2
17	17703-ZL8-800	TUBE, FUEL RETURN	1	-----	MHA2,QHA2
18	17704-ZL8-800	TUBE, FUEL PUMP	1	-----	MHA2,QHAJ,QHA2
19	80103-MG2-000	CUSHION, RR. FENDER	1	-----	DHAF,MHA2,PHA,QBC,QDE,QFC,QHA,QHAF,QHA1,QHA2,QHC,VHA,VXA
20	90041-ZL8-000	BOLT, FUEL TANK STUD	1	-----	DHAF,MHA2,PHA,QBC,QDE,QFC,QHA,QHAF,QHA1,QHA2,QHC,VHA,VXA
21	90473-896-000	WASHER, 6MM	1	-----	DHAF,MHA2,PHA,QBC,QDE,QFC,QHA,QHAF,QHA1,QHA2,QHC,VHA,VXA
22	90501-KA2-640	COLLAR, 14X6.1	2	-----	DHAF,MHA2,PHA,QBC,QDE,QFC,QHA,QHAF,QHA1,QHA2,QHC,VHA,VXA
23	93404-06025-00	BOLT-WASHER, 6X25	2	-----	DHAF,MHA2,PHA,QBC,QDE,QFC,QHA,QHAF,QHA1,QHA2,QHC,VHA,VXA
24	93894-05014-00	SCREW-WASHER, 5X14	2		



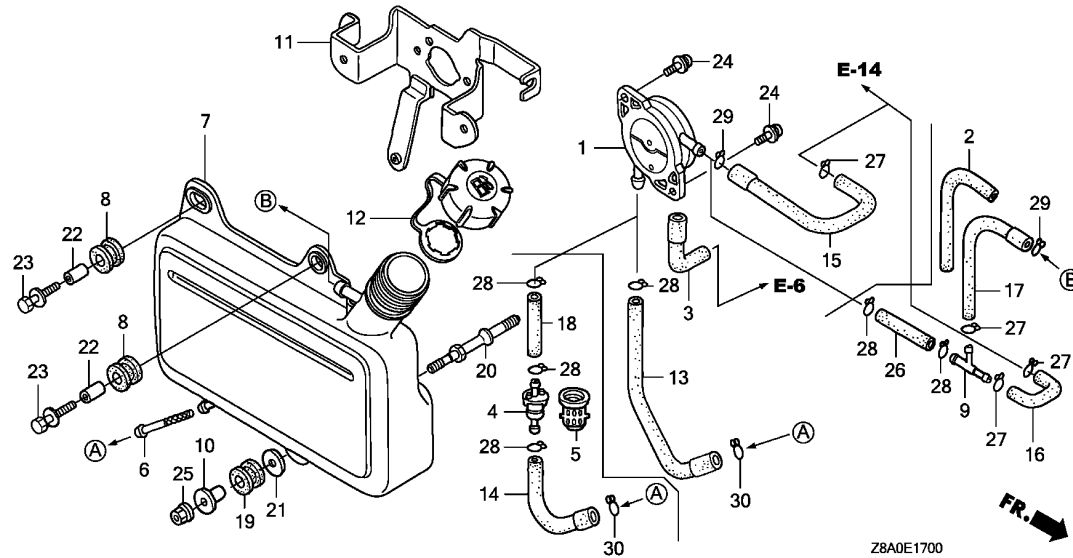

Ref. No.	Part No.	Description	Reqd. QTY		Serial No.	Parts catalogue code
			GC	LA		
25	94050-06000	NUT, FLANGE, 6MM	1		-----	DHAF,MHA2,PHA,QBC,QDE,QFC,QHA,QHAF,QHA1,QHA2,QHC,VHA,VXA
26	95001-55033-40	TUBE, FUEL, 5.3X33 (95001-55001-60M)	1		-----	MHA2,QHA2
27	95002-02080	CLIP, TUBE (B8)	1		-----	DHAF,PHA,QBC,QDE,QFC,QHA,QHAF,QHAJ,QHA1,QHC,VHA,VXA
28	95002-02100	CLIP, TUBE (B10)	3		-----	MHA2,QHA2
			1		-----	DHAF,PHA,QBC,QDE,QFC,QHA,QHAF,QHA1,QHC,VHA,VXA
			2		-----	QHAJ
			5		-----	MHA2,QHA2
29	95002-50000	CLIP, TUBE (C9)	1		-----	
30	95002-70000	CLIP, TUBE (C11)	1		-----	DHAF,MHA2,PHA,QBC,QDE,QFC,QHA,QHAF,QHA1,QHA2,QHC,VHA,VXA

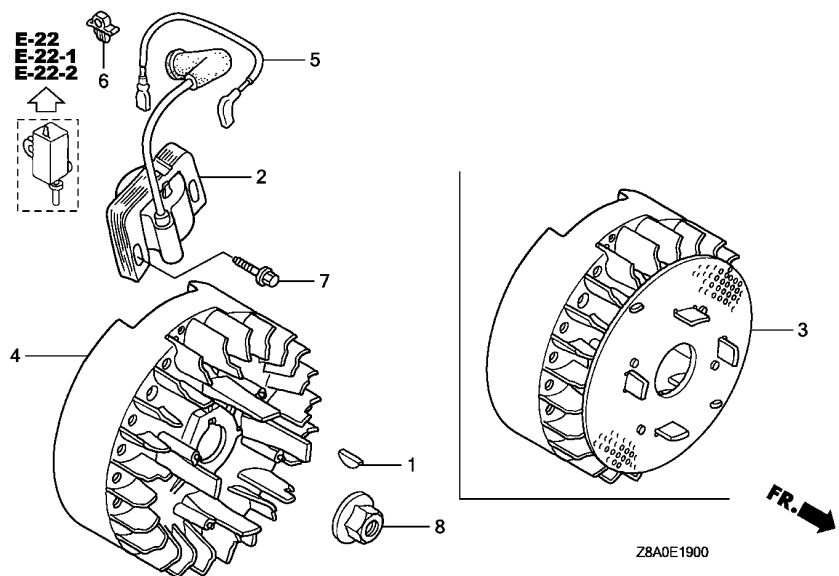

Service item F.R.T.

Ref. No.	Part No.	Description	Reqd. QTY		Serial No.	Parts catalogue code
			GC	LA		
1	13331-357-000	KEY, SPECIAL WOODRUFF, 25X18	1			
2	30500-Z0J-003	COIL ASSY., IGNITION (PHELON) (USE FOR F/W OF PHELON)	1			
3	31105-Z0J-010	FLYWHEEL ASSY. (PHELON) (USE FOR IGN. COIL OF PHELON)	1	-----	----- QHAJ	
4	31110-Z0J-013	FLYWHEEL COMP. (PHELON) (USE FOR IGN. COIL OF PHELON)	1	-----	----- DHAF,MHA2,PHA,QBC,QDE,QFC,QHA,QHAF,QHA1,QHA2,QHC,VHA,VXA	
5	32195-Z0J-000	CORD, STOP SWITCH	1	-----	----- MHA2,PHA,QBC,QDE,QFC,QHA,QHAJ,QHA1,QHA2,QHC,VHA	
6	36103-ZE1-000	HOLDER, STOP SWITCH CORD	1	-----	----- MHA2,PHA,QBC,QDE,QFC,QHA,QHAJ,QHA1,QHA2,QHC,VHA	
	51125-Z0L-003	HOLDER, WIRE (FASTEX)	1	-----	----- MHA2,PHA,QBC,QDE,QFC,QHA,QHAJ,QHA1,QHA2,QHC,VHA	
7	90022-888-010	BOLT, FLANGE, 6X20(CT200) ...	1			
8	90201-878-003	NUT, SPECIAL, 14MM	1			



E-19-10

OIL ALERT/OIL LEVEL SWITCH

C14

Service item F.R.T.

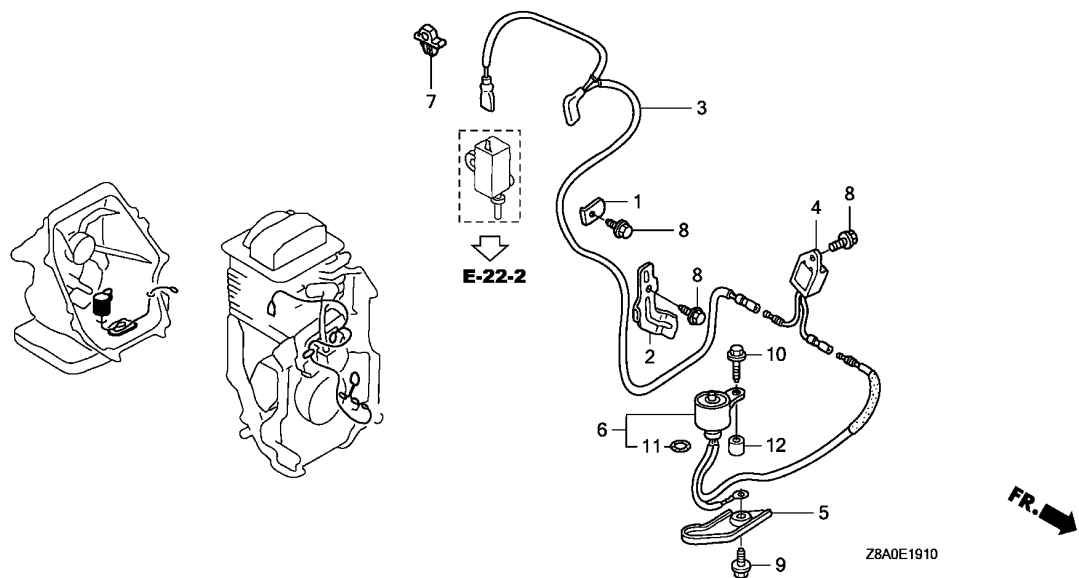

Ref. No.	Part No.	Description	Reqd. QTY		Serial No.	Parts catalogue code
			GC	160 LA		
1	30548-ZL8-000	CLAMPER, STOP SWITCH CORD ...	1	-----	-----	VXA
2	30549-ZL8-000	CLAMPER, CORD	1	-----	-----	VXA
3	32195-ZOJ-810	CORD, STOP SWITCH	1	-----	-----	VXA
4	34150-ZL8-003	ALERT UNIT, OIL	1	-----	-----	VXA
5	35419-ZL8-000	PROTECTOR, SWITCH	1	-----	-----	VXA
6	35480-ZL8-811	SWITCH COMP., OIL LEVEL	1	-----	-----	VXA
7	36103-ZE1-000	HOLDER, STOP SWITCH CORD	1	-----	-----	VXA
	51125-ZOL-003	HOLDER, WIRE (FASTEX)	1	-----	-----	VXA
8	90013-883-000	BOLT, FLANGE, 6X12(CT200) ...	3	-----	-----	VXA
9	90014-952-000	BOLT, FLANGE, 6X14(CT200) ...	1	-----	-----	VXA
10	90015-883-000	BOLT, FLANGE, 6X28	1	-----	-----	VXA
11	91302-ZL8-003	O-RING, 11.8X2.4	1	-----	-----	VXA
12	91501-ZL8-000	COLLAR, 6.6X13.8X14.5	1	-----	-----	VXA

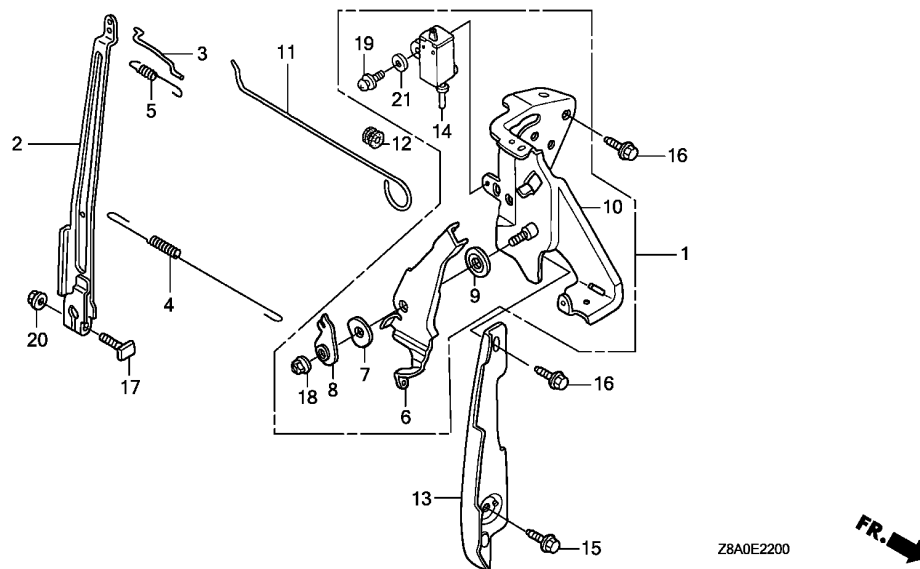

Service item F.R.T.

Ref. No.	Part No.	Description	Reqd. QTY		Serial No.	Parts catalogue code
			GC 160 LA			
1	16500-ZL8-000	CONTROL ASSY.	1	-----	MHA2,PHA,QBC,QFC,QHA,QHA2,QHC	
2	16551-ZL8-000	ARM, GOVERNOR	1	-----	MHA2,PHA,QBC,QFC,QHA,QHA2,QHC	
3	16555-ZL8-000	ROD, GOVERNOR	1	-----	MHA2,PHA,QBC,QFC,QHA,QHA2,QHC	
4	16561-ZL8-V50	SPRING, GOVERNOR	1	-----	QBC,QFC	
	16561-Z0J-000	1	-----	MHA2,PHA,QHA,QHA2,QHC	
5	16562-ZL8-800	SPRING, THROTTLE RETURN	1	-----	MHA2,PHA,QBC,QFC,QHA,QHA2,QHC	
6	16571-ZL8-000	LEVER, CONTROL	1	-----	MHA2,PHA,QBC,QFC,QHA,QHA2,QHC	
7	16574-ZE1-000	SPRING, LEVER	1	-----	MHA2,PHA,QBC,QFC,QHA,QHA2,QHC	
8	16575-ZL8-000	WASHER, CONTROL LEVER (###) ..	1	-----	MHA2,PHA,QBC,QFC,QHA,QHA2,QHC	
9	16578-ZE1-000	SPACER, CONTROL LEVER	1	-----	MHA2,PHA,QBC,QFC,QHA,QHA2,QHC	
10	16580-ZL8-000	BASE COMP., CONTROL (###) ...	1	-----	MHA2,PHA,QBC,QFC,QHA,QHA2,QHC	
11	16611-ZL8-000	ROD, CHOKE CONTROL	1	-----	MHA2,PHA,QBC,QFC,QHA,QHA2,QHC	
12	16613-893-000	GROMMET, CHOKE ROD	1	-----	MHA2,PHA,QBC,QFC,QHA,QHA2,QHC	
13	19612-Z0L-000	PLATE, SIDE	1	-----	MHA2,PHA,QBC,QFC,QHA,QHA2,QHC	
14	35120-ZL8-003	SWITCH ASSY., ENGINE STOP				
		(N.O)	1	-----	MHA2,PHA,QBC,QFC,QHA,QHA2,QHC	
15	90013-883-000	BOLT, FLANGE, 6X12(CT200) ...	1	-----	MHA2,PHA,QBC,QFC,QHA,QHA2,QHC	
16	90014-952-000	BOLT, FLANGE, 6X14(CT200) ...	2	-----	MHA2,PHA,QBC,QFC,QHA,QHA2,QHC	
17	90015-ZE5-010	BOLT, GOVERNOR ARM	1	-----	MHA2,PHA,QBC,QFC,QHA,QHA2,QHC	
18	90114-SAO-000	NUT, SELF-LOCK, 6MM	1	-----	MHA2,PHA,QBC,QFC,QHA,QHA2,QHC	
19	93892-04012-00	SCREW-WASHER, 4X12	1	-----	MHA2,PHA,QBC,QFC,QHA,QHA2,QHC	
20	94050-06000	NUT, FLANGE, 6MM	1	-----	MHA2,PHA,QBC,QFC,QHA,QHA2,QHC	
21	94103-04000	WASHER, PLAIN, 4MM	1	-----	MHA2,PHA,QBC,QFC,QHA,QHA2,QHC	



E-22-1

CONTROL(2)

C16

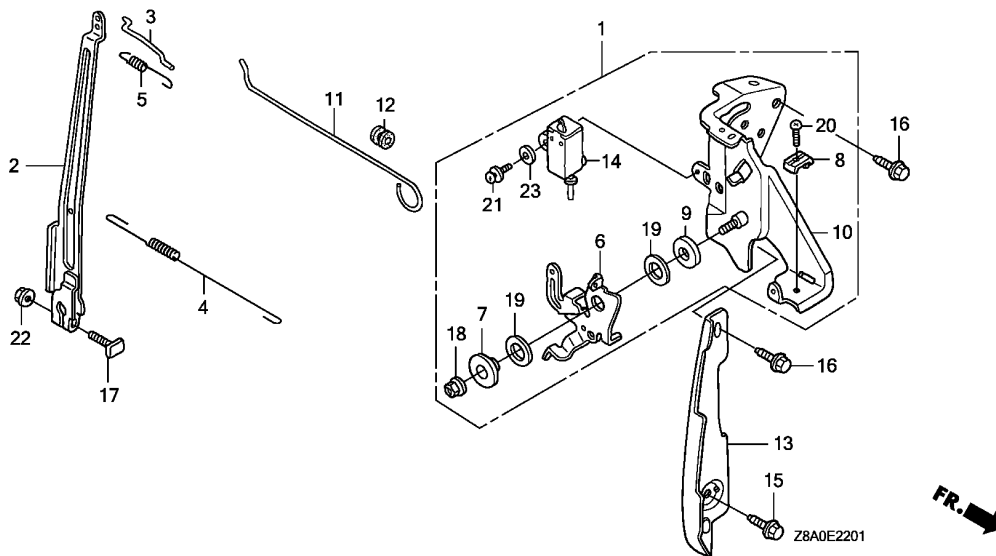

Service item F.R.T.

Ref. No.	Part No.	Description	Reqd. QTY		Serial No.	Parts catalogue code
			GC 160 LA			
1	16500-ZL8-800	CONTROL ASSY.	1	-----	-----	QDE,QHAJ,QHA1
2	16551-ZL8-000	ARM, GOVERNOR	1	-----	-----	QDE,QHAJ,QHA1
3	16555-ZL8-000	ROD, GOVERNOR	1	-----	-----	QDE,QHAJ,QHA1
4	16561-Z0J-000	SPRING, GOVERNOR	1	-----	-----	QDE,QHAJ,QHA1
5	16562-ZL8-800	SPRING, THROTTLE RETURN	1	-----	-----	QDE,QHAJ,QHA1
6	16571-ZL8-800	LEVER, CONTROL	1	-----	-----	QDE,QHAJ,QHA1
7	16575-ZL8-800	WASHER, CONTROL LEVER (###) ..	1	-----	-----	QDE,QHAJ,QHA1
8	16576-891-000	HOLDER, CABLE	1	-----	-----	QDE,QHAJ,QHA1
9	16578-ZL8-800	SPACER, CONTROL LEVER (###) ..	1	-----	-----	QDE,QHAJ,QHA1
10	16580-ZL8-000	BASE COMP., CONTROL (###) ...	1	-----	-----	QDE,QHAJ,QHA1
11	16611-ZL8-000	ROD, CHOKE CONTROL	1	-----	-----	QDE,QHAJ,QHA1
12	16613-893-000	GROMMET, CHOKE ROD	1	-----	-----	QDE,QHAJ,QHA1
13	19612-Z0L-000	PLATE, SIDE	1	-----	-----	QDE,QHAJ,QHA1
14	35120-ZL8-003	SWITCH ASSY., ENGINE STOP (N.O)	1	-----	-----	QDE,QHAJ,QHA1
15	90013-883-000	BOLT, FLANGE, 6X12(CT200) ...	1	-----	-----	QDE,QHAJ,QHA1
16	90014-952-000	BOLT, FLANGE, 6X14(CT200) ...	2	-----	-----	QDE,QHAJ,QHA1
17	90015-ZE5-010	BOLT, GOVERNOR ARM	1	-----	-----	QDE,QHAJ,QHA1
18	90114-SA0-000	NUT, SELF-LOCK, 6MM	1	-----	-----	QDE,QHAJ,QHA1
19	90452-KG8-000	WASHER, 12.5MM	2	-----	-----	QDE,QHAJ,QHA1
20	93500-05016-0A	SCREW, PAN, 5X16	1	-----	-----	QDE,QHAJ,QHA1
21	93892-04012-00	SCREW-WASHER, 4X12	1	-----	-----	QDE,QHAJ,QHA1
22	94050-06000	NUT, FLANGE, 6MM	1	-----	-----	QDE,QHAJ,QHA1
23	94103-04000	WASHER, PLAIN, 4MM	1	-----	-----	QDE,QHAJ,QHA1

E-22-2

CONTROL(3)

D 1

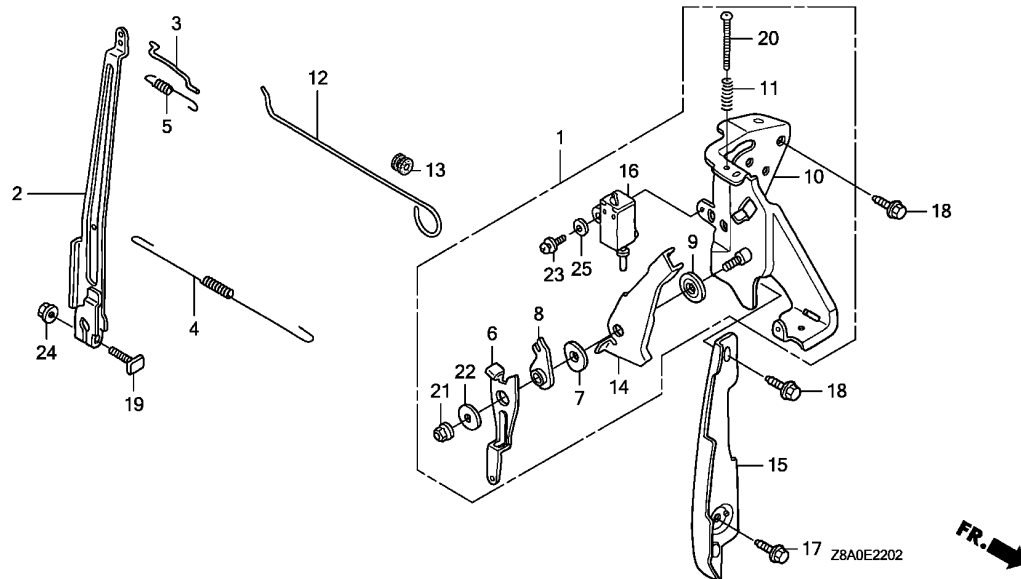

Service item F.R.T.

Ref. No.	Part No.	Description	Reqd. QTY		Serial No.	Parts catalogue code
			GC	160 LA		
1	16500-ZL8-850	CONTROL ASSY.	1	-----	-----	VHA,VXA
2	16551-ZL8-000	ARM, GOVERNOR	1	-----	-----	VHA,VXA
3	16555-ZL8-000	ROD, GOVERNOR	1	-----	-----	VHA,VXA
4	16561-ZL8-810	SPRING, GOVERNOR	1	-----	-----	VHA,VXA
5	16562-ZL8-800	SPRING, THROTTLE RETURN	1	-----	-----	VHA,VXA
6	16571-ZL8-850	LEVER, CONTROL	1	-----	-----	VHA,VXA
7	16574-ZE1-000	SPRING, LEVER	1	-----	-----	VHA,VXA
8	16575-ZL8-000	WASHER, CONTROL LEVER (###) ..	1	-----	-----	VHA,VXA
9	16578-ZE1-000	SPACER, CONTROL LEVER	1	-----	-----	VHA,VXA
10	16580-ZL8-000	BASE COMP., CONTROL (###) ...	1	-----	-----	VHA,VXA
11	16584-883-300	SPRING, CONTROL ADJUSTING ...	1	-----	-----	VHA,VXA
12	16611-ZL8-000	ROD, CHOKE CONTROL	1	-----	-----	VHA,VXA
13	16613-893-000	GROMMET, CHOKE ROD	1	-----	-----	VHA,VXA
14	16631-ZL8-850	LEVER, STOP (###)	1	-----	-----	VHA,VXA
15	19612-ZOL-000	PLATE, SIDE	1	-----	-----	VHA,VXA
16	35120-ZL8-003	SWITCH ASSY., ENGINE STOP (N.O)	1	-----	-----	VHA,VXA
17	90013-883-000	BOLT, FLANGE, 6X12(CT200) ...	1	-----	-----	VHA,VXA
18	90014-952-000	BOLT, FLANGE, 6X14(CT200) ...	2	-----	-----	VHA,VXA
19	90015-ZE5-010	BOLT, GOVERNOR ARM	1	-----	-----	VHA,VXA
20	90031-ZL8-850	SCREW, ADJUST	1	-----	-----	VHA,VXA
21	90114-SAO-000	NUT, SELF-LOCK, 6MM	1	-----	-----	VHA,VXA
22	90563-355-000	WASHER, WHEEL, 6MM	1	-----	-----	VHA,VXA
23	93892-04012-00	SCREW-WASHER, 4X12	1	-----	-----	VHA,VXA
24	94050-06000	NUT, FLANGE, 6MM	1	-----	-----	VHA,VXA
25	94103-04000	WASHER, PLAIN, 4MM	1	-----	-----	VHA,VXA

2

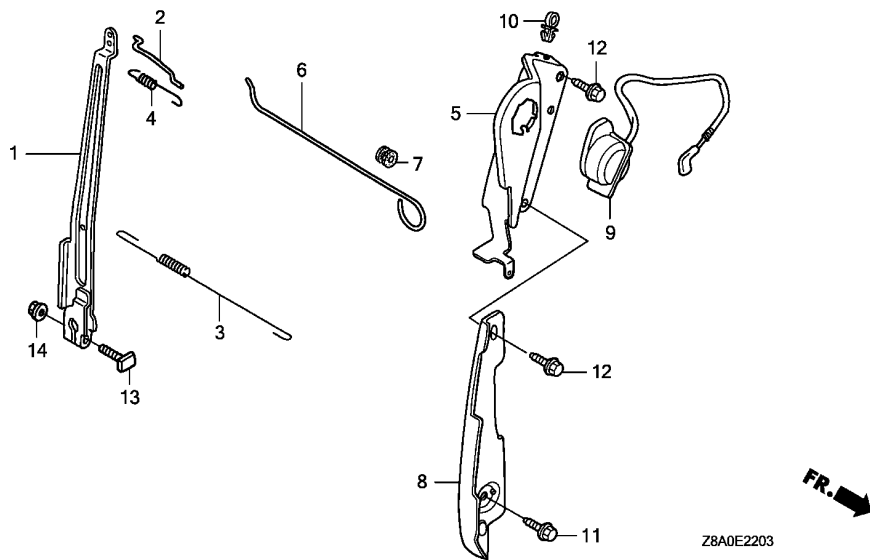

Service item

F.R.T.

2

Ref. No.	Part No.	Description	Reqd. QTY		Serial No.	Parts catalogue code
			GC 160 LA			
1	16551-ZL8-000	ARM, GOVERNOR	1	-----	-----	DHAF,QHAF
2	16555-ZL8-000	ROD, GOVERNOR	1	-----	-----	DHAF,QHAF
3	16561-ZOJ-000	SPRING, GOVERNOR	1	-----	-----	DHAF,QHAF
4	16562-ZL8-800	SPRING, THROTTLE RETURN	1	-----	-----	DHAF,QHAF
5	16581-ZOJ-800	BASE, CONTROL	1	-----	-----	DHAF,QHAF
6	16611-ZL8-000	ROD, CHOKE CONTROL	1	-----	-----	DHAF,QHAF
7	16613-893-000	GROMMET, CHOKE ROD	1	-----	-----	DHAF,QHAF
8	19612-ZOL-000	PLATE, SIDE	1	-----	-----	DHAF,QHAF
9	35120-ZOJ-801	SWITCH ASSY., ENGINE STOP	1	-----	-----	DHAF,QHAF
10	51125-ZOL-003	HOLDER, WIRE (FASTEX)	1	-----	-----	DHAF,QHAF
	90681-959-003	CLIP A, CABLE (NIFCO)	1	-----	-----	DHAF,QHAF
11	90013-883-000	BOLT, FLANGE, 6X12(CT200)	1	-----	-----	DHAF,QHAF
12	90014-952-000	BOLT, FLANGE, 6X14(CT200)	2	-----	-----	DHAF,QHAF
13	90015-ZE5-010	BOLT, GOVERNOR ARM	1	-----	-----	DHAF,QHAF
14	94050-06000	NUT, FLANGE, 6MM	1	-----	-----	DHAF,QHAF

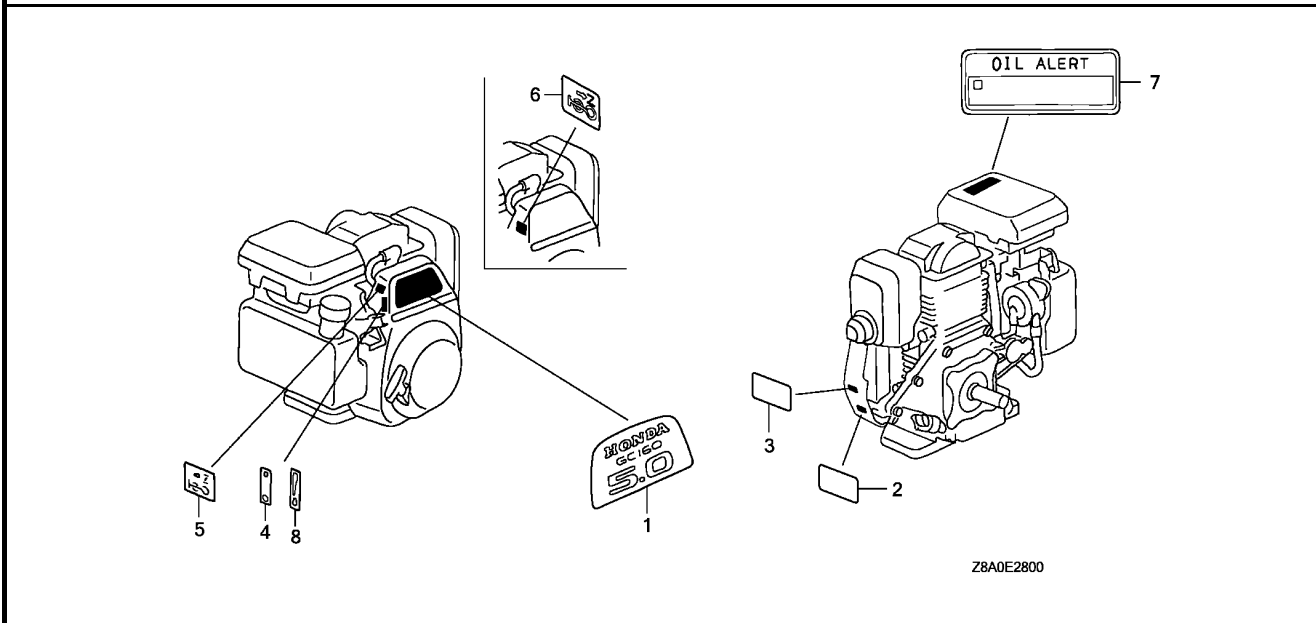

Service item	F.R.T.
--------------	--------

Ref. No.	Part No.	Description	Reqd. QTY	Serial No.	Parts catalogue code
			GC 160 LA		
1	87101-ZL8-010	EMBLEM (GC160 5.0)	1	-----	MHA2,PHA,QBC,QDE,QFC,QHA,QHAF,QHAJ,QHA1,QHA2,QHC,VHA,VXA
2	87114-ZH7-821	LABEL, WARNING (NOT CERTIFIED FOR SALE)	1	-----	MHA2,PHA,QBC,QDE,QFC,QHA,QHAJ,QHA1,QHA2,QHC,VHA,VXA
3	87114-ZH7-821	LABEL, WARNING (NOT CERTIFIED FOR SALE)	1	-----	DHAF,QHAF
4	87501-ZL8-000	MARK, ENGINE SWITCH INDICATION	1	-----	VHA,VXA
5	87528-ZL8-000	MARK, CHOKE	1	-----	MHA2,PHA,QBC,QDE,QFC,QHA,QHAJ,QHA1,QHA2,QHC,VHA,VXA
6	87528-ZL8-000	MARK, CHOKE	1	-----	DHAF,QHAF
7	87530-ZL8-850	MARK, OIL ALERT (ENGLISH)	1	-----	VXA
8	87532-ZL8-800	MARK, THROTTLE INDICATION	1	-----	MHA2,PHA,QBC,QFC,QHA,QHA2,QHC



PART NO. INDEX

Part Number	Address	Page	Ref.	Part Number	Address	Page	Ref.	Part Number	Address	Page	Ref.	Part Number	Address	Page	Ref.	Part Number	Address	Page	Ref.	
06000				16029-ZG0-901	C8	18	7	16882-ZL8-000	C11	21	3	31000								
06180-Z0J-000	C10	20	1	16100-Z0J-003	C8	18	8	16910-ZV4-015	C11	21	4									
11000				16155-ZL8-013	C8	18	9	16915-ZV4-000	C11	21	5	31105-Z0J-010	C13	23	3					
11300-Z0J-405	C2	12	1	16166-ZL8-003	C8	18	10	16952-ZA8-800	C11	21	6	31110-Z0J-013	C13	23	4	90013-ZL8-000				
11300-ZL8-405	C2	12	1	16211-ZL8-000	C8	18	11								90014-952-000					
11300-ZL8-406	C2	12	1	16212-ZL8-000	C8	18	12	17000				32000								
11300-ZL8-409	C2	12	1	16221-883-800	C8	18	13													
12000				16228-ZL8-000	C8	18	14	17211-ZL8-023	C9	19	2	32195-Z0J-000	C13	23	5					
12000-ZL8-425	C1	11	1	16500-ZL8-000	C15	25	1	17220-ZL8-000	C9	19	3	32195-Z0J-810	C14	24	3					
12209-ZM0-003	C1	11	2	16500-ZL8-800	C16	26	1	17228-ZL8-000	C9	19	4									
12310-Z0J-000	C1	11	3	16500-ZL8-850	D1	27	1	17231-Z0J-020	C9	19	5	34000				90015-883-000				
12355-ZL8-000	C1	11	4	16510-ZL8-000	C2	12	5	17511-Z0J-000	C11	21	7					90015-ZE5-010				
13000				16531-ZE1-000	C2	12	6	17511-Z0J-800	C11	21	7	34150-ZL8-003	C14	24	4					
13010-Z0L-014	C4	14	1	16541-ZL8-000	C2	12	7	17516-ZV0-000	C11	21	8									
13101-Z2A-010	C4	14	2	16551-ZL8-000	C15	25	2	17519-ZL8-800	C11	21	9	35000								
13111-ZE0-000	C4	14	3		C16	26	2	17535-166-000	C11	21	10					90022-888-010				
13200-Z0J-000	C4	14	4	16555-ZL8-000	C16	26	3	17561-Z0J-000	C11	21	11	35120-Z0J-801	D2	28	9	90031-ZL8-850				
13310-Z0J-651	C3	13	4		D1	27	2	17620-Z0J-800	C11	21	12	35120-ZL8-003	C15	25	14	90041-ZL8-000				
13310-Z0J-660	C3	13	5		D2	28	1	17701-ZL8-000	C11	21	13					90043-ZL8-000				
13310-ZL8-600	C3	13	1		C15	25	3	17701-ZL8-800	C11	21	14					90055-ZE1-000				
13310-ZL8-650	C3	13	2		C16	26	3	17702-ZL8-000	C11	21	15	35419-ZL8-000	C14	24	5					
13310-ZL8-671	C3	13	3		D1	27	3	17702-ZL8-800	C11	21	16	35480-ZL8-811	C14	24	6	90114-SA0-000				
13331-357-000	C13	23	1		D2	28	3	17703-ZL8-800	C11	21	17									
14000					D2	28	3	17704-ZL8-800	C11	21	18	36000								
14320-ZL8-010	C5	15	1		D1	27	3									90121-952-000				
14324-ZL8-000	C5	15	2		D2	28	3									90131-883-000				
14400-Z0J-014	C5	15	3		D2	28	3									90201-878-003				
14431-Z0J-000	C5	15	4		D2	28	3									90201-ZM0-000				
14441-Z0J-000	C5	15	5		D2	28	3									90206-001-000				
14461-ZL8-000	C5	15	6		D2	28	3									90402-ZL8-000				
14711-Z0J-000	C1	11	5		D2	28	3									90451-ZE1-000				
14721-ZL8-000	C1	11	6		D2	28	3									90452-KG8-000				
14751-ZL8-000	C1	11	7		D2	28	3									90473-896-000				
14771-Z0J-000	C1	11	8		D2	28	3									90501-KA2-640				
15000					D2	28	3									90551-ZE0-000				
15625-Z2L-801	C2	12	2		D2	28	3									90563-355-000				
15631-ZL8-000	C2	12	3		D2	28	3									90602-ZE1-000				
15650-Z2L-801	C2	12	4		D2	28	3									90681-959-003				
15721-ZL8-000	C9	19	1		D2	28	3													
16000					D2	28	3													
16010-883-015	C8	18	1		D2	28	3													
16013-ZL1-003	C8	18	2		D2	28	3													
16015-ZL8-003	C8	18	3		D2	28	3													
16016-ZG0-W00	C8	18	4		D2	28	3													
16024-124-760	C8	18	5		D2	28	3													
16028-ZE0-005	C8	18	6		D2	28	3													
					D2	28	3													

PART NO. INDEX

E 2

Part Number	Address	Page	Ref.	Part Number	Address	Page	Ref.	Part Number	Address	Page	Ref.	Part Number	Address	Page	Ref.
94000															
94050-06000	C12	22	25												
	C15	25	20												
	C16	26	22												
	D1	27	24												
	D2	28	14												
94101-06800	C2	12	16												
94103-04000	C15	25	21												
	C16	26	23												
	D1	27	25												
94109-12000	C2	12	17												
94251-08000	C2	12	18												
94301-08200	C2	12	19												
95000															
95001-55033-40	C12	22	26												
95002-02080	C12	22	27												
95002-02100	C12	22	28												
95002-02650	C8	18	17												
95002-50000	C12	22	29												
95002-70000	C12	22	30												
95003-07015-31	C8	18	18												
98000															
98079-56846	C1	11	12												
99000															
99101-124-0600	C8	18	19												
99101-124-0620	C8	18	19												
99101-124-0650	C8	18	19												

3

PART NAME INDEX

F 1

Part name	Address	Page	Ref.	Part name	Address	Page	Ref.	Part name	Address	Page	Ref.
[A]								[H]			
ALERT UNIT, OIL	C14	24	4	CLIP A, CABLE	D2	28	10	HOLDER, CABLE	C16	26	8
ARM, EX. VALVE ROCKER	C5	15	5	CLIP, GOVERNOR HOLDER	C2	12	12	HOLDER, STOP SWITCH CORD	C13	23	6
ARM, GOVERNOR	C15	25	2	CLIP, PISTON PIN, 13MM	C4	14	6		C14	24	7
	C16	26	2	CLIP, TUBE	C8	18	17	HOLDER, WIRE	C13	23	6
	D1	27	2		C12	22	27		C14	24	7
	D2	28	1						D2	28	10
ARM, IN. VALVE ROCKER	C5	15	4	COIL ASSY., IGNITION	C13	23	2	[I]			
ARRESTER COMP., SPARK	C10	20	5	COLLAR, 14X6.1	C11	21	22	INSULATOR, CARBURETOR	C8	18	11
ARRESTER KIT, SPARK	C10	20	1	COLLAR, 6.6X13.8X14.5	C14	24	12	[J]			
[B]				COLLAR, FAN COVER	C7	17	2	JET, MAIN,	C8	18	19
BARREL ASSY., CYLINDER	C1	11	1	COLLAR, FR. COVER SETTING	C11	21	10	JOINT, FUEL TUBE	C11	21	9
BASE COMP., CONTROL	C15	25	10	CONTROL ASSY.	C15	25	1	[K]			
	C16	26	10		C16	26	1	KEY, SPECIAL WOODRUFF, 25X18 ..	C13	23	1
	D1	27	10		D1	27	1	[L]			
BASE, CONTROL	D2	28	5	CORD, STOP SWITCH	C13	23	5	LABEL, WARNING	D3	29	2
BEARING, RADIAL BALL, 62/28 ..	C2	12	13		C14	24	3	LEVER, CONTROL	C15	25	6
BELT, TIMING	C5	15	3	COVER ASSY., CRANKCASE	C2	12	1		C16	26	6
BOLT-WASHER, 6X25	C11	21	23	COVER COMP., BREATHER	C1	11	4	LEVER, STOP	D1	27	6
BOLT, CONNECTING ROD	C4	14	5	COVER COMP., CYLINDER HEAD ..	C1	11	3		D1	27	6
BOLT, DRAIN PLUG, 12X15	C2	12	10	COVER, AIR CLEANER	C9	19	5		D1	27	6
BOLT, FLANGE, 6X112	C9	19	6	COVER, FAN	C7	17	1		D1	27	14
BOLT, FLANGE, 6X12	C1	11	9	CRANKSHAFT COMP.	C3	13	1	[M]			
	C10	20	10					MARK, CHOKE	D3	29	5
	C14	24	8	CUSHION, RR. FENDER	C11	21	19				
	C15	25	15	[D]				MARK, ENGINE SWITCH INDICATION	D3	29	4
	C16	26	15	DEFLECTOR COMP., MUFFLER	C10	20	8	MARK, OIL ALERT	D3	29	7
	D1	27	17	DOWEL PIN, 8X20	C2	12	19	MARK, THROTTLE INDICATION	D3	29	8
	D2	28	11	[E]				MUFFLER COMP.	C10	20	2
BOLT, FLANGE, 6X14	C1	11	10	ELEMENT, AIR CLEANER	C9	19	2	[N]			
	C2	12	8	EMBLEM	D3	29	1	NOZZLE, MAIN	C8	18	10
	C14	24	9	EXTENSION, OIL FILLER	C2	12	3	NUT, FLANGE, 6MM	C7	17	4
	C15	25	16	[F]					C12	22	25
	C16	26	16	FLOAT SET	C8	18	2		C15	25	20
	D1	27	18	FLYWHEEL ASSY.	C13	23	3		C16	26	22
	D2	28	12	FLYWHEEL COMP.	C13	23	4		D1	27	24
BOLT, FLANGE, 6X20	C13	23	7	[G]					D2	28	14
BOLT, FLANGE, 6X25	C2	12	9	GASKET, MUFFLER	C10	20	7		C15	25	18
BOLT, FLANGE, 6X28	C14	24	10	GAUGE ASSY., OIL LEVEL	C2	12	4		C16	26	18
BOLT, FLANGE, 6X79	C10	20	9	GOVERNOR ASSY.	C2	12	5		D1	27	21
BOLT, FUEL TANK STUD	C11	21	20	GRIP, STARTER	C6	16	2	NUT, SPECIAL, 14MM	C13	23	8
BOLT, GOVERNOR ARM	C15	25	17	GROMMET, CHOKE ROD	C15	25	12	NUT, TAPPET ADJUSTING	C5	15	8
	C16	26	17	[O]							
	D1	27	19	OIL SEAL, 25.4X62X6	C1	11	11				
	D2	28	13	OIL SEAL, 28X41.25X6	C2	12	14				
BOLT, STUD	C7	17	3								
[C]											
CAP ASSY., FUEL TANK	C11	21	12								
CAP, MUFFLER	C10	20	4								
CARBURETOR ASSY.	C8	18	8								
CASE COMP., AIR CLEANER	C9	19	3								
CHAMBER SET, FLOAT	C8	18	3								
CLAMPER, CORD	C14	24	2								
CLAMPER, STOP SWITCH CORD	C14	24	1								

PART NAME INDEX

F 2

Part name	Address	Page	Ref.	Part name	Address	Page	Ref.	Part name	Address	Page	Ref.
O-RING, 11.8X2.4	C14	24	11	SEAL, VALVE STEM	C1	11	2	WASHER, PLAIN, 4MM	C15	25	21
O-RING, 22.5X2.2	C2	12	15	SHAFT, CAM PULLEY	C5	15	2		C16	26	23
O-RING, 6.8X1.9	C5	15	9	SHAFT, GOVERNOR ARM	C2	12	7		D1	27	25
[P]				SHAFT, ROCKER ARM	C5	15	6	WASHER, PLAIN, 6MM	C2	12	16
PACKING SET	C8	18	1	SLIDER, GOVERNOR	C2	12	6	WASHER, THRUST	C3	13	6
PACKING, AIR CLEANER	C9	19	4	SPACER, CONTROL LEVER	C15	25	9	WASHER, THRUST, 6MM	C2	12	11
PACKING, CARBURETOR	C8	18	13		C16	26	9	WASHER, WHEEL, 6MM	D1	27	22
					D1	27	9				
PACKING, INSULATOR	C8	18	12	SPRING, CONTROL ADJUSTING	D1	27	11				
PACKING, OIL FILLER CAP	C2	12	2	SPRING, GOVERNOR	C15	25	4				
PIN, LOCK, 8MM	C2	12	18		C16	26	4				
PIN, PISTON	C4	14	3		D1	27	4				
PISTON	C4	14	2	SPRING, LEVER	C15	25	7				
PLATE, ARRESTER NUMBER	C10	20	6		D1	27	7				
PLATE, SIDE	C15	25	13	SPRING, THROTTLE RETURN	C15	25	5				
	C16	26	13		C16	26	5				
	D1	27	15		D1	27	5				
	D2	28	8	SPRING, VALVE	D2	28	4				
PLUG, SPARK	C1	11	12		C1	11	7				
PROTECTOR, MUFFLER	C10	20	3	STARTER ASSY., RECOIL	C6	16	1				
PROTECTOR, SWITCH	C14	24	5	STAY A, FUEL TANK	C11	21	11				
PULLEY COMP., CAMSHAFT	C5	15	1	STRAINER COMP., FUEL	C11	21	4				
PUMP ASSY., FUEL	C11	21	1	STRAINER, FUEL	C11	21	6				
[R]				SUSPENSION, STRAINER	C11	21	5				
RETAINER, VALVE SPRING	C1	11	8	SWITCH ASSY., ENGINE STOP	C15	25	14				
RING SET, PISTON	C4	14	1		C16	26	14				
ROD ASSY., CONNECTING	C4	14	4		D1	27	16				
ROD, CHOKE CONTROL	C15	25	11	SWITCH COMP., OIL LEVEL	C14	24	6				
	C16	26	11	[T]							
	D1	27	12	TANK, FUEL	C11	21	7				
	D2	28	6	TUBE, BREATHER	C9	19	1				
ROD, GOVERNOR	C15	25	3	TUBE, DIAPHRAGM	C11	21	3				
	C16	26	3	TUBE, FUEL	C11	21	15				
	D1	27	3								
	D2	28	2	TUBE, FUEL PUMP	C11	21	18				
ROPE, RECOIL STARTER	C6	16	3	TUBE, FUEL RETURN	C11	21	17				
RUBBER B, TANK MOUNTING	C11	21	8	TUBE, FUEL TANK	C11	21	13				
RUBBER, SUPPORTER	C11	21	2								
[S]				TUBE, FUEL, 5.3X33	C12	22	26				
SCREW-WASHER, 4X12	C15	25	19	TUBE, VINYL, 4X7X150	C8	18	18				
	C16	26	21	[V]							
	D1	27	23	VALVE COMP., FLOAT	C8	18	9				
SCREW-WASHER, 5X14	C11	21	24	VALVE, EX.	C1	11	6				
SCREW SET	C8	18	4	VALVE, IN.	C1	11	5				
				[W]							
				WASHER, 12.5MM	C16	26	19				
SCREW SET, DRAIN	C8	18	5	WASHER, 6MM	C11	21	21				
SCREW, ADJUST	D1	27	20	WASHER, CONTROL LEVER	C15	25	8				
SCREW, PAN, 5X16	C16	26	20		C16	26	7				
SCREW, PAN, 5X6	C8	18	16	WASHER, DRAIN PLUG, 12MM	D1	27	8				
SCREW, TAPPET ADJUSTING	C5	15	7		C2	12	17				
SCREW, TAPPING, 4X6	C10	20	11								

1

FOREWORD INDEX

2

ENGINE GROUP

3

PART NUMBER INDEX

4

PART NAME INDEX

HONDA
The Power of Dreams

May 24, 2007



PARTS CATALOG NEWS

Honda Motor Co., Ltd. Service Division

PARTS CATALOG - CORRECTED

Printed in Japan

CODE NO.	14Z8A701
PARTS CATALOG NEWS	GC160LA
NEWS NO.	001

Block No.	Ref. No.	Note	Part No.	Description	Reqd. QTY GC 160 LA	Serial No.	Parts catalog code
-----------	----------	------	----------	-------------	------------------------------	------------	--------------------

E-16 MUFFLER

ILLUSTRATION CORRECTED

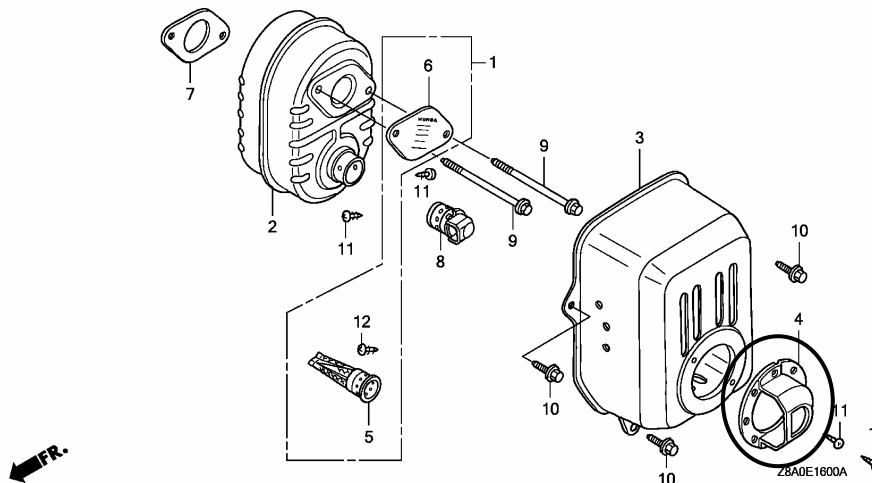

NOTE A:PART NO. CHANGE D:NEWLY PROVIDED E:PART NO. DELETION K:REQUIRED NO. CORRECTION L:APPLICATION SERIAL NO. CORRECTION
T:APPLICATION CORRECTION Z:REMARKS CHANGE

February 17, 2008



PARTS CATALOG NEWS

Honda Motor Co., Ltd. Service Division

PARTS CATALOG - CORRECTED

Printed in Japan

CODE NO.	14Z8A701
PARTS CATALOG NEWS	GC160LA
NEWS NO.	002

Block No.	Ref. No.	Note	Part No.	Description	Reqd. QTY GC 160 LA	Serial No.	Parts catalog code
E-14	4	L	16016-ZG0-W00	SCREW SET (CARBURETOR NO.)	1	----- BB61J A	DHAF, QHAF
	7	L	16029-ZG0-901	SCREW SET (THROTTLE STOP) (CARBURETOR NO.)	1	----- BB61J A	DHAF, QHAF

NOTE A:PART NO. CHANGE D:NEWLY PROVIDED E:PART NO. DELETION K:REQUIRED NO. CORRECTION L:APPLICATION SERIAL NO. CORRECTION
T:APPLICATION CORRECTION Z:REMARKS CHANGE

April 06, 2008



PARTS CATALOG NEWS

Honda Motor Co., Ltd. Service Division

PARTS CATALOG - CORRECTED

Printed in Japan

CODE NO.	14Z8A701
PARTS CATALOG NEWS	GC160LA
NEWS NO.	003

Block No.	Ref. No.	Note	Part No.	Description	Reqd. QTY	Serial No.	Parts catalog code
-----------	----------	------	----------	-------------	-----------	------------	--------------------

ENGINE SERIAL No. OF GC160LA CORRECTED

Model	Type	Parts catalogue type	Applicable engine serial No.
GC160LA	DHAF	DHAF	GCAHA-3599750~
	MHAB	MHAB	
	MHA2	MHA2	
	PHA	PHA	
	QBC	QBC	
	QDE	QDE	
	QFC	QFC	
	QHA	QHA	
	QHAF	QHAF	
	QHAJ	QHAJ	
	QHA1	QHA1	
	QHA2	QHA2	
	QHC	QHC	
	VHA	VHA	
VXA	VXA		

NOTE A:PART NO. CHANGE D:NEWLY PROVIDED E:PART NO.DELETION K:REQUIRED NO. CORRECTION L:APPLICATION SERIAL NO. CORRECTION
 T:APPLICATION CORRECTION Z:REMARKS CHANGE

September 19, 2008



PARTS CATALOG NEWS

Honda Motor Co., Ltd. Service Division

PARTS CATALOG - CORRECTED

Printed in Japan

CODE NO.	14Z8A701
PARTS CATALOG NEWS	GC160LA
NEWS NO.	004

Block No.	Ref. No.	Note	Part No.	Description	Reqd. QTY GC 160 LA	Serial No.	Parts catalog code
E-22	2	E	16551-ZL8-000	*PARTS NO. DELETION			
		T	16551-ZL8-010	ARM, GOVERNOR	1	-----	MHA2, PHA, QBC, QFC, QHA, QHA2, QHC
E-22-1	2	E	16551-ZL8-000	*PARTS NO. DELETION			
		D	16551-ZL8-010	ARM, GOVERNOR	1	-----	QDE, QHAJ, QHA1
E-22-2	2	E	16551-ZL8-000	*PARTS NO. DELETION			
		D	16551-ZL8-010	ARM, GOVERNOR	1	-----	VHA, VXA
E-22-3	1	E	16551-ZL8-000	*PARTS NO. DELETION			
		D	16551-ZL8-010	ARM, GOVERNOR	1	-----	DHAF, QHAF

NOTE A:PART NO. CHANGE D:NEWLY PROVIDED E:PART NO. DELETION K:REQUIRED NO. CORRECTION L:APPLICATION SERIAL NO. CORRECTION
T:APPLICATION CORRECTION Z:REMARKS CHANGE

October 16, 2008



PARTS CATALOG NEWS

Honda Motor Co., Ltd. Service Division

PARTS CATALOG - CORRECTED

Printed in Japan

CODE NO.	14Z8A701
PARTS CATALOG NEWS	GC160LA
NEWS NO.	005

Block No.	Ref. No.	Note	Part No.	Description	Reqd. QTY GC 160 LA	Serial No.	Parts catalog code
E-14	4	L	16016-ZG0-W00	SCREW SET (CARBURETOR NO.)	1	BB61J A BB61J A DHAF, QHAF	
	7	L	16029-ZG0-901	SCREW SET (THROTTLE STOP) (CARBURETOR NO.)	1	BB61J A BB61J A DHAF, QHAF	

NOTE A:PART NO. CHANGE D:NEWLY PROVIDED E:PART NO. DELETION K:REQUIRED NO. CORRECTION L:APPLICATION SERIAL NO. CORRECTION
T:APPLICATION CORRECTION Z:REMARKS CHANGE



PARTS CATALOG NEWS

Honda Motor Co., Ltd. Service Division

PARTS CATALOG - CORRECTED

Printed in Japan

CODE NO.	14Z8A701
PARTS CATALOG NEWS	GC160LA
NEWS NO.	006

Block No.	Ref. No.	Note	Part No.	Description	Reqd. QTY GC 160 LA	Serial No.	Parts catalog code
-----------	----------	------	----------	-------------	------------------------------	------------	--------------------

E-28 LABEL

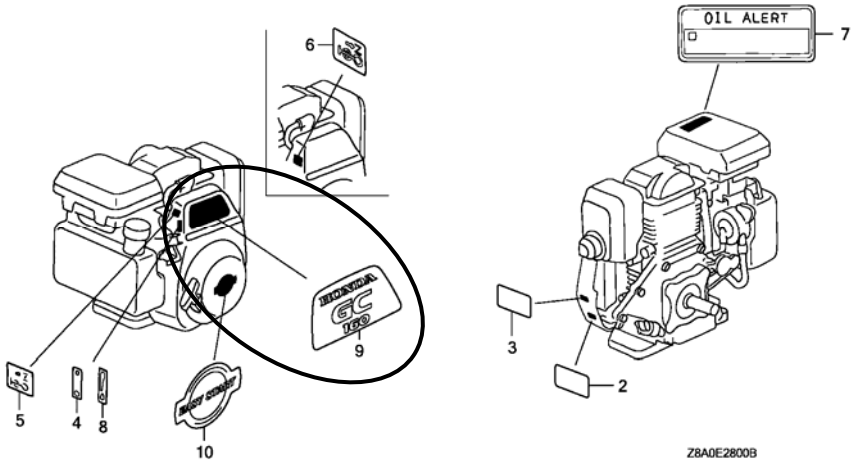

Z8A0E2800B

E-28	1	E	87101-ZL8-010	*PARTS NO. DELETION			
	9	T	87101-ZL8-020	EMBLEM (GC160)	1	-----	MHA2, PHA, QBC, QDE, QFC, QHA, QHAF, QHAJ, QHA1, QHA2, QHC, VHA, VXA

NOTE A:PART NO. CHANGE D:NEWLY PROVIDED E:PART NO. DELETION K:REQUIRED NO. CORRECTION L:APPLICATION SERIAL NO. CORRECTION
T:APPLICATION CORRECTION Z:REMARKS CHANGE