

General Purpose Engine

GCV160A
(TYPE S3H)

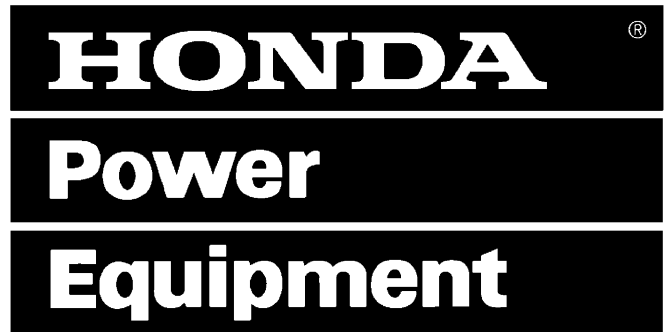

Parts Catalog

MAY, 2006

American Honda Motor Co., Inc.

For Discount Troy Bilt Parts Call 606-678-9623 or 606-561-4983

TABLE OF CONTENTS

Introduction

Grid / Page

- HOW TO USE THIS CATALOG A2 4
- SERIAL NUMBERS A3 6
- BULK HOSE PART NUMBER PATTERN..... A3 7
- MASTER INDEX A4 8

Part Groups

- ENGINE SECTION 1-C1 1-1

Index

- PART NUMBER INDEX B1 2-1
- DESCRIPTION INDEX 1-D1 3-1

HOW TO USE THIS CATALOG

CATALOG/CATALOGUE PAGE BREAKDOWN (Generic layout-sample data only)

MODEL		TYPE								(11)
A = MODEL		a=TYPE								B-1
B = MODEL		b=TYPE								
C = MODEL		c=TYPE								
(4)										
Ref	Description	(3) Mod	(6) Type	Engine Serial Number		ORG	QTY	Part Number	H/C	
1	COVER SET, CYLINDER HEAD	4	b	15240057	-----	JPN	1	12310-PE2-020	2031797	
	COVER SET, CYLINDER HEAD			-----	12234811	USA	1	12310-PE2-030	2210888	
(1)	(2)			(5)		(7)	(8)	(9)	(10)	

KEY TO CATALOG/CATALOGUE PAGE BREAKDOWN

1. Ref - Reference numbers correspond to the reference numbers on the illustrations. All illustrations are representative only, and do not necessarily look exactly like the actual part. "NI" signifies the part is not illustrated. Reference numbers may be skipped when they apply to other models.

2. Description* - Describes the part for the related part number.

Abbreviations:

ASSY. - Assembly	A.C. - Alternating Current
L(100L) - Link(100Links)	D.C. - Direct Current
R. - Right	KPH - Kilometers Per Hour
L. - Left	MPH - Miles Per Hour
IN. - Inlet	A.M. - Attaching Mark
EX. - Exhaust	T.M. - Transcript Mark
FR. - Front	A - Ampere
RR. - Rear	WL - With Labeling
HEX. - Hexagonal	WOL - Without Labeling
STD. - Standard	T (22T) - Tooth
MM - Millimeter	C.D.I. - Capacitive Discharge Ignition
G - Gram	G.F.C.I. - Ground Fault Circuit Interruptor
V - Volt	
W - Watt	

3. Mod* - Model alpha labeling is unique per catalog/catalogue (not consistent with other catalogs/catalogues).

4. Each model and type in the catalog/catalogue is represented by an alpha label.

5. Serial Number - Applies to Engine or Frame serial numbers depending on the section. The serial numbers of a unit (frame, engine, carburetor) should be checked prior to ordering parts for the unit. In cases where a part has been modified, the beginning and/or ending serial number of the unit bearing the modification is listed in the "SERIAL NUMBER" column. Modification parts can be controlled by three types of numbers as described below.

Engine serial number - Engine group parts (Block numbers beginning with "E").

Carburetor identification number - Carburetor component parts.

Frame serial number - Frame group parts (Block numbers beginning with "F").

Note 1 - A modification that does not follow the pattern above will be clarified by a comment located below the part description. A serial number chart and a guide to serial number locations are provided in the front portion of the catalog/catalogue.

Note 2 - Although most models will be identified by Engine and Frame serial numbers, some models may be identified by one serial number only - either Engine serial number or Frame serial number.

6. Type* - Model Type is defined in the serial number chart.

7. ORG* - Manufacturing country of origin of the unit.

8. QTY - Quantity required for the specified Block/Section.
 A. "AR" in place of the quantity indicates AS REQUIRED.
 B. "(") Parentheses in the quantity indicate "optional".

9. Part Number - Part number corresponds to the reference number and application. Several part numbers may be listed under one (1) reference number.
 Note: For U.S. only - For your convenience the current supersede chain, as of print date, has been listed. Supersede chains are subject to change without notice.

10. H/C - The Honda Code and Part Number share a 1 to 1 relationship (U.S.A. only).

11. The Block Number identifies the catalog/catalogue section.

CONSTRUCTION OF PART NUMBERS

All parts are classified into two groups, "GENERAL PARTS" and "STANDARD PARTS". All parts are numbered according to the system described below:

General Parts

Example: Driver Seat Assembly Part No. 77400-634-671ZA
 Function No. 77
 Component No. 400
 Model Code No. -634-
 Modification Process Design 671
 Color/colour Indicator** ZA

Standard Parts

Example: 8 x 18 Hex. bolt Part No. 92000-08018-0A
 Function No. 92000
 Dimensions -08018-
 ISO Standard Designation 0
 Chemical Surface Treatment A

**The color/colour indicator at the end of a part number signifies a color/colour. These color/colour indicators such as ZA, ZB, ZC . . . , except ZZ, do not identify the actual color/colour. Actual colors/colours are identified by a code that appears between asterisks in the part description.

Additional Information - The section index located at the bottom of each microfiche grid lists section titles. The Engine and Frame sections have separate section indexes.

Some Block Titles are numbered, such as Air Cleaner (1), Air Cleaner (3), Muffler (2) or Muffler (4), etc. These may skip numbers when some blocks apply in other volumes of the same model(s).

*When columns become full, additional data is displayed on a second line.

This page intentionally left blank.

SERIAL NUMBERS

Models and applicable serial numbers

Models and applicable serial numbers given in this parts catalog can be identified as follows.

Model	Type	Applicable Engine Serial No.	Applicable Frame Serial No.	Applicable Carburetor Identification
GCV160A	S3H	GJAEA-1000001~	—	BB62S A

BULK HOSE PART NUMBER PATTERN

Construction of Fuel and Vacuum Hose Part Number

Example: 9 5 0 0 1 - 7 5 0 0 1 - 4 0 M

Roll Hose

All roll hose part numbers have an "M" in this position

Appearance Code

Fuel Hose:

- 2 = Red, braided exterior
- 3 = Red
- 4 = Ash Gray with red stripe
- 5 = Black, braided interior
- 6 = Black

Vinyl Hose:

- 1 = Ash Gray
- 2 = Black
- 3 = Light Red
- 6 = Light Red
- 7 = Pale Black

Vacuum Hose:

- 1 = Ash Gray
- 2 = Ash Gray
- 3 = Black
- 5 = Black

Length

Cut Hose length is in *Millimeters (mm)*

Bulk Hose length is in *Meters (M)*

Inside Diameter

Fuel and Vacuum Hose

- | | |
|-----------------------|------------------------------|
| 35 = 3.5 mm | 11 = 11 mm |
| 45 = 4.5 mm | 91 = 12 (outside dia. 15) mm |
| 50 = 5.0 mm | 92 = 12 (outside dia. 16) mm |
| 55 = 5.3 mm or 5.5 mm | 12 = 12 (outside dia. 17) mm |
| 65 = 6.5 mm | 14 = 14 mm |
| 70 = 7.0 mm | 17 = 17 mm |
| 75 = 7.3 mm or 7.5 mm | |
| 80 = 8.0 mm | |

ID./OD. Code : Vinyl Hose

- | | | |
|--------------------------|----------------------------|----------------------------|
| 01 = ID. 2.9, OD. 6.8 mm | 14 = ID. 6.0, OD. 9.0 mm | 37 = ID. 11.0, OD. 15.0 mm |
| 03 = ID. 3.0, OD. 6.0 mm | 17 = ID. 7.0, OD. 9.0 mm | 38 = ID. 12.0, OD. 13.0 mm |
| 05 = ID. 3.5, OD. 6.5 mm | 19 = ID. 7.0, OD. 11.0 mm | 39 = ID. 12.0, OD. 14.0 mm |
| 07 = ID. 4.0, OD. 7.0 mm | 21 = ID. 8.0, OD. 9.0 mm | 40 = ID. 12.0, OD. 16.0 mm |
| 08 = ID. 4.5, OD. 6.5 mm | 23 = ID. 8.0, OD. 12.0 mm | 43 = ID. 13.0, OD. 15.0 mm |
| 09 = ID. 4.5, OD. 8.0 mm | 25 = ID. 9.0, OD. 11.0 mm | 45 = ID. 14.0, OD. 18.0 mm |
| 12 = ID. 5.0, OD. 7.0 mm | 27 = ID. 9.0, OD. 13.0 mm | 50 = ID. 16.0, OD. 19.0 mm |
| 10 = ID. 5.0, OD. 8.0 mm | 33 = ID. 10.0, OD. 14.0 mm | 55 = ID. 17.5, OD. 20.5 mm |
| 11 = ID. 5.0, OD. 9.0 mm | 36 = ID. 11.0, OD. 13.0 mm | 60 = ID. 22.0, OD. 27.0 mm |

Hose Type:

- 1 = Fuel Hose
- 3 = Vinyl Hose
- 5 = Vacuum Hose

CAUTION: Never use vacuum / or vinyl hose in place of fuel hose or vice versa

MASTER INDEX

Title	Grid	Page	Title	Grid	Page
ENGINE SECTION					
CYLINDER	1-C1	1-2			
OIL PAN	1-C1	1-3			
CRANKSHAFT	1-C2	1-5			
PISTON • CONNECTING ROD.....	1-C3	1-6			
CAMSHAFT PULLEY	1-C3	1-7			
RECOIL STARTER	1-C4	1-8			
FAN COVER	1-C4	1-9			
CARBURETOR	1-C5	1-10			
AIR CLEANER	1-C6	1-12			
MUFFLER	1-C6	1-13			
FLYWHEEL (1)	1-C7	1-14			
CONTROL (3)	1-C7	1-15			

ENGINE SECTION
Chapter Table of Contents

Page Title	Grid	Page
CYLINDER	1-C1	1-2
OIL PAN	1-C1	1-3
CRANKSHAFT	1-C2	1-5
PISTON • CONNECTING ROD	1-C3	1-6
CAMSHAFT PULLEY	1-C3	1-7
RECOIL STARTER	1-C4	1-8
FAN COVER	1-C4	1-9
CARBURETOR	1-C5	1-10
AIR CLEANER	1-C6	1-12
MUFFLER	1-C6	1-13
FLYWHEEL (1)	1-C7	1-14
CONTROL (3)	1-C7	1-15

CYLINDER

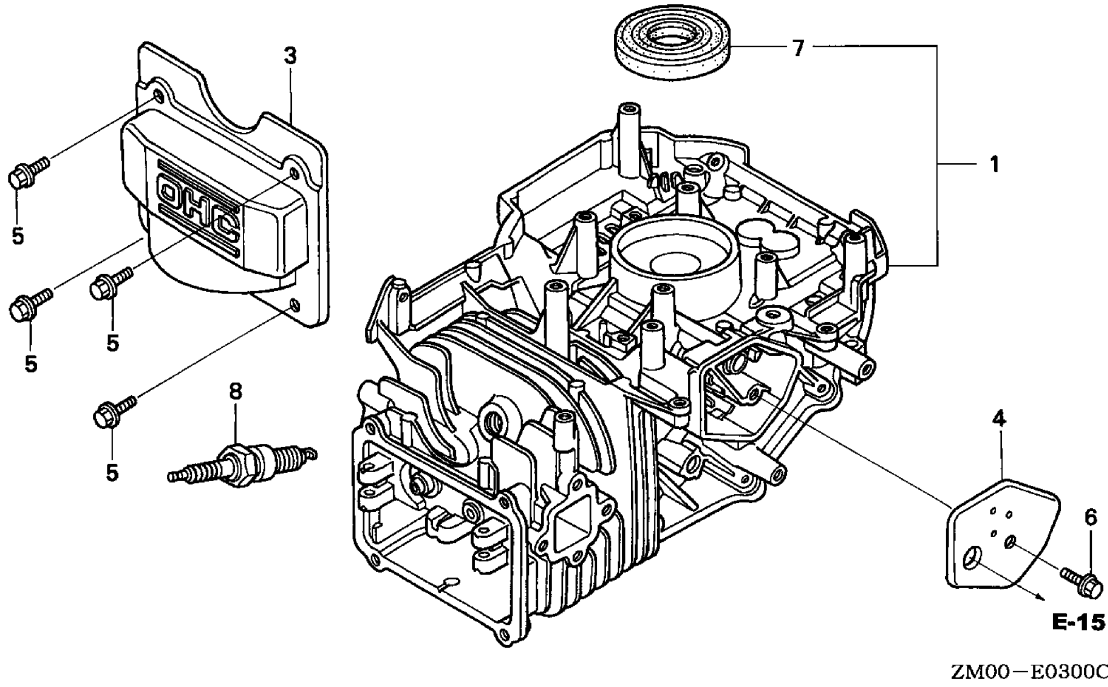

ZM00E0300C

MODEL
A =GCV160A

TYPE
a =S3H

E-3

Ref	Description	Engine Serial Number		QTY	Part Number	H/C
		From	To			
1	CYLINDER ASSY.	-----	-----	1	12000-Z0L-406	8018277
3	COVER, HEAD	-----	-----	1	12311-ZL8-D00	6325211
	COVER, HEAD	-----	-----	1	12311-ZL8-000	5579990
4	COVER, BREATHER (BREATHER VALVE ASSY.)	-----	-----	1	12355-ZL8-000	5580006
5	BOLT, FLANGE (6X12) (CT200)	-----	-----	4	90013-883-000	0636845
6	BOLT, FLANGE (6X14)	-----	-----	1	90014-952-000	0803619
7	OIL SEAL (25.4X62X6).....	-----	-----	1	91201-ZL8-003	5581038
8	SPARK PLUG (BPR6ES) (NGK)	-----	-----	1	98079-56846	1441112

OIL PAN

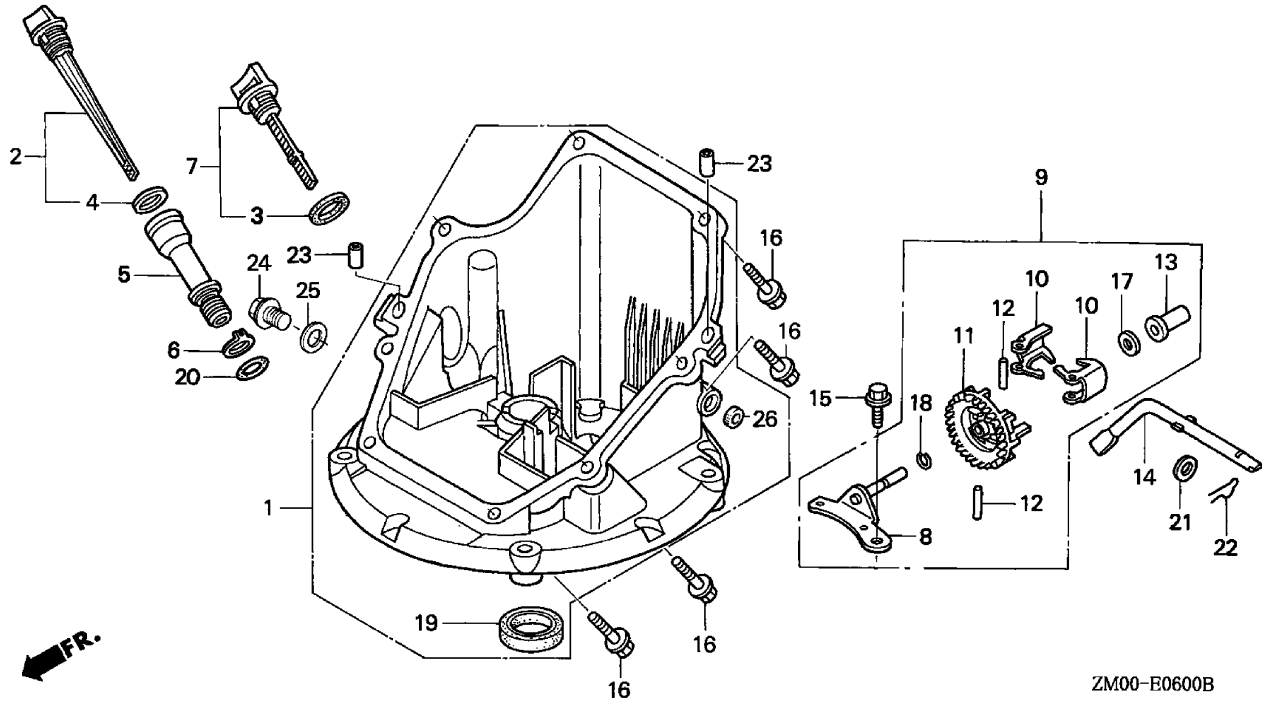

ZM00-B0600B

ZM00E0600B

MODEL
A =GCV160A

TYPE
a =S3H

E-6

Ref	Description	Engine Serial Number		QTY	Part Number	H/C
		From	To			
1	PAN ASSY., OIL (000)	-----	-----	1	11300-ZM0-405	6315675
	PAN ASSY., OIL	-----	-----	1	11300-ZM0-811	6771489
2	DIPSTICK, OIL	-----	-----	1	15650-ZM0-801	5716915
4	GASKET, OIL FILLER CAP	-----	-----	1	15625-ZE6-000	1452754
5	EXTENSION, OIL FILLER	-----	-----	1	15631-ZM0-000	5664503
6	WASHER, EXTENSION LOCK	-----	-----	1	15639-ZM0-000	5664511
8	SHAFT, GOVERNOR HOLDER	-----	-----	1	16508-ZM0-010	6384341
9	GOVERNOR ASSY.	-----	-----	1	16510-ZM0-010	6384333
10	WEIGHT, GOVERNOR	-----	-----	2	16511-ZL8-000	5580287
11	HOLDER, GOVERNOR WEIGHT	-----	-----	1	16512-ZM0-000	5580295
12	PIN, GOVERNOR WEIGHT	-----	-----	2	16513-ZE1-000	1427244
13	SLIDER, GOVERNOR	-----	-----	1	16531-ZE1-000	1427251
14	SHAFT, GOVERNOR ARM	-----	-----	1	16541-ZM0-000	5580303
15	BOLT, FLANGE (6X14)	-----	-----	1	90014-952-000	0803619
16	BOLT, FLANGE (6X25)	-----	-----	8	90121-952-000	0748111
17	WASHER, THRUST (6MM)	-----	-----	1	90451-ZE1-000	2413862
18	CLIP, GOVERNOR HOLDER	-----	-----	1	90602-ZE1-000	2456697
19	OIL SEAL (28X41.25X6)	-----	-----	1	91202-ZL8-003	5581046

OIL PAN

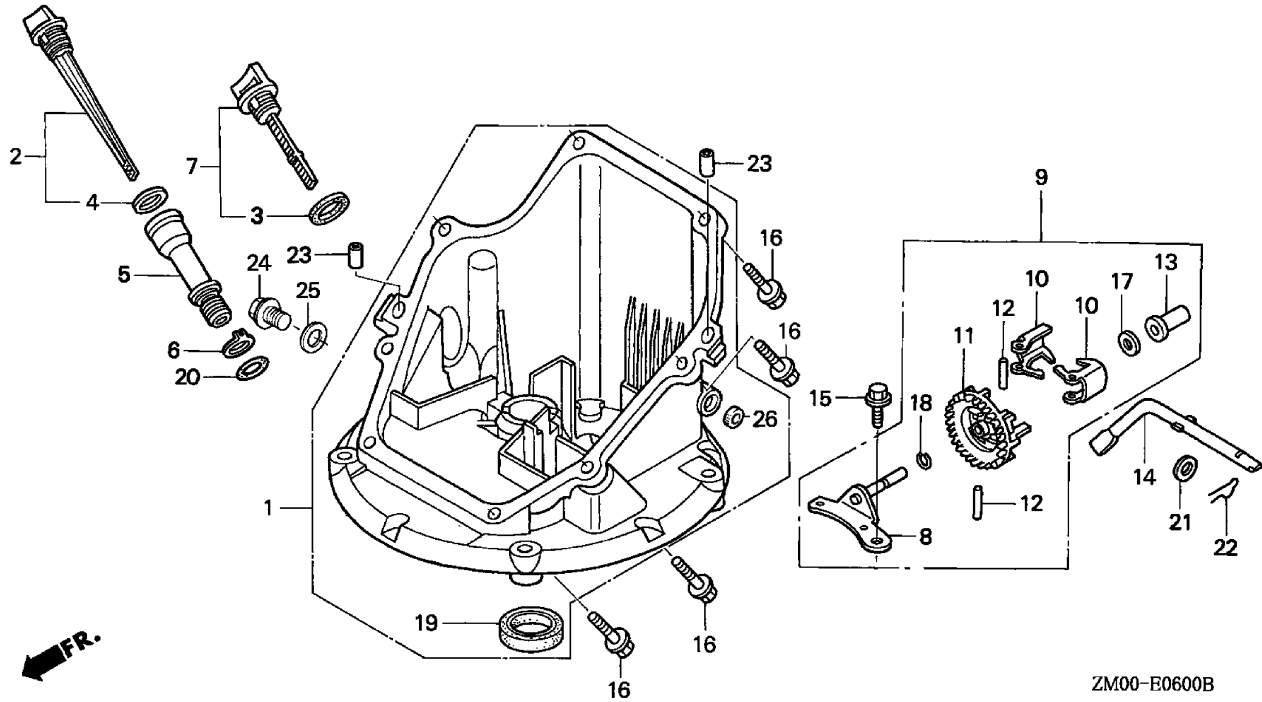

ZM00-E0600B

ZM00E0600B

MODEL
A =GCV160A

TYPE
a =S3H

E-6

Ref	Description	Engine Serial Number		QTY	Part Number	H/C
		From	To			
20	O-RING (14.8X2.4) (NOK)	-----	-----	1	91356-MA6-005	1377704
21	WASHER, PLAIN (6MM)	-----	-----	1	94101-06800	0345900
22	PIN, LOCK (8MM).....	-----	-----	1	94251-08000	0115527
23	PIN, DOWEL (8X20).....	-----	-----	2	94301-08200	1417369

CRANKSHAFT

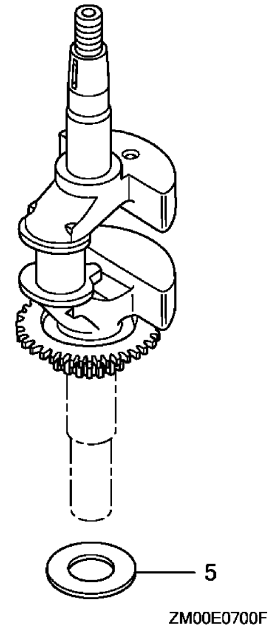
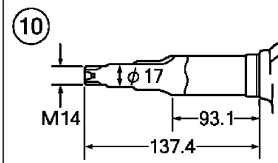
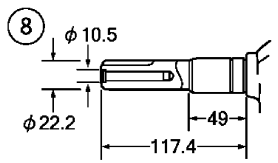
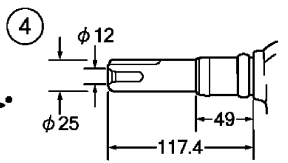
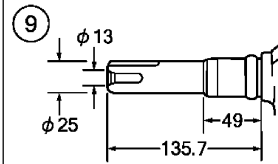
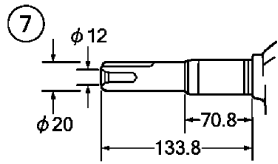
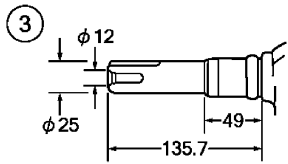
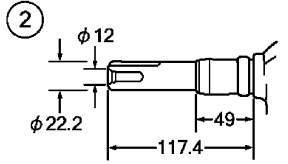
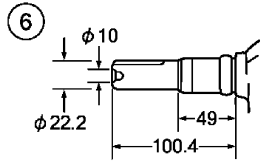
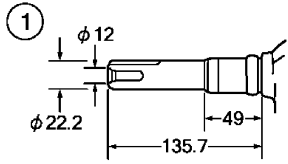

ZM00E0700F

MODEL
A =GCV160A

TYPE
a =S3H

E-7

Ref	Description	Engine Serial Number		QTY	Part Number	H/C
		From	To			
3	CRANKSHAFT (N3-TYPE).....	-----	-----	1	13310-ZM0-610	5664495
5	WASHER, THRUST	-----	-----	1	90402-ZL8-000	5581012

PISTON • CONNECTING ROD

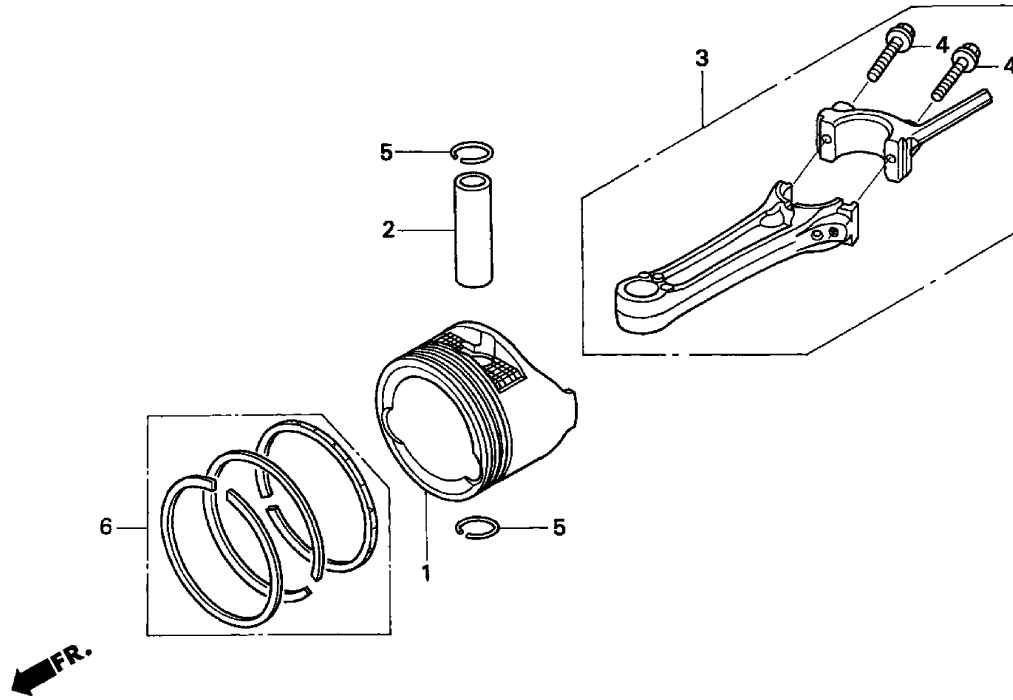

ZM00-E0800A

ZM00E0800A

MODEL
A =GCV160A

TYPE
a =S3H

E-8

Ref	Description	Engine Serial Number		QTY	Part Number	H/C
		From	To			
1	PISTON	-----	-----	1	13101-Z2A-000	7595705
2	PIN, PISTON	-----	-----	1	13111-ZE0-000	1426576
3	ROD ASSY., CONNECTING	-----	-----	1	13200-ZL8-000	5580022
4	BOLT, CONNECTING ROD	-----	-----	2	90001-ZE1-000	1431055
5	CLIP, PISTON PIN (13MM)	-----	-----	2	90551-ZE0-000	2605517
6	RING SET, PISTON (RIKEN)	-----	-----	1	13010-Z0L-003	8018327
	RING SET, PISTON (TEIKOKU)	-----	-----	1	13010-Z0L-004	8018335

CAMSHAFT PULLEY

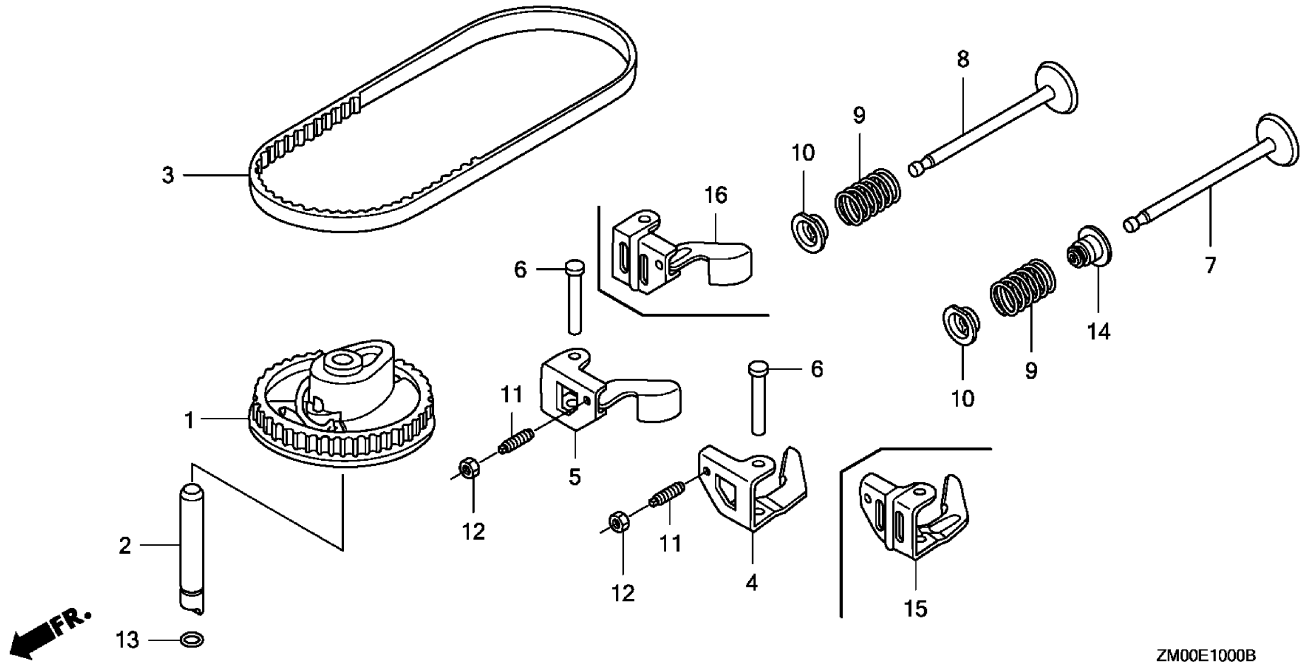

ZM00E1000B

ZM00E1000B

MODEL
A =GCV160A

TYPE
a =S3H

E-10

Ref	Description	Engine Serial Number		QTY	Part Number	H/C
		From	To			
1	PULLEY, CAMSHAFT	-----	-----	1	14320-ZL8-010	7049679
2	SHAFT, CAM PULLEY	-----	-----	1	14324-ZL8-000	5580063
3	BELT, TIMING (84HU7 G-200).....	-----	-----	1	14400-Z0J-014	7058985
6	SHAFT, ROCKER ARM	-----	-----	2	14461-ZL8-000	5580105
7	VALVE, IN.	-----	-----	1	14711-Z0J-000	7647118
8	VALVE, EX.	-----	-----	1	14721-ZL8-000	5580121
9	SPRING, VALVE	-----	-----	2	14751-ZL8-000	5580139
10	RETAINER, VALVE SPRING	-----	-----	2	14771-Z0J-000	7526148
11	SCREW, TAPPET ADJ.	-----	-----	2	90012-333-000	0294819
12	NUT, TAPPET ADJ.	-----	-----	2	90206-001-000	0004598
13	O-RING (6.8X1.9).....	-----	-----	1	91301-ZM0-V31	6315873
14	SEAL, VALVE STEM	-----	-----	1	12209-ZM0-003	6839831
15	ARM, IN. VALVE ROCKER	-----	-----	1	14431-Z0J-000	7526122
16	ARM, EX. VALVE ROCKER.....	-----	-----	1	14441-Z0J-000	7526130

RECOIL STARTER

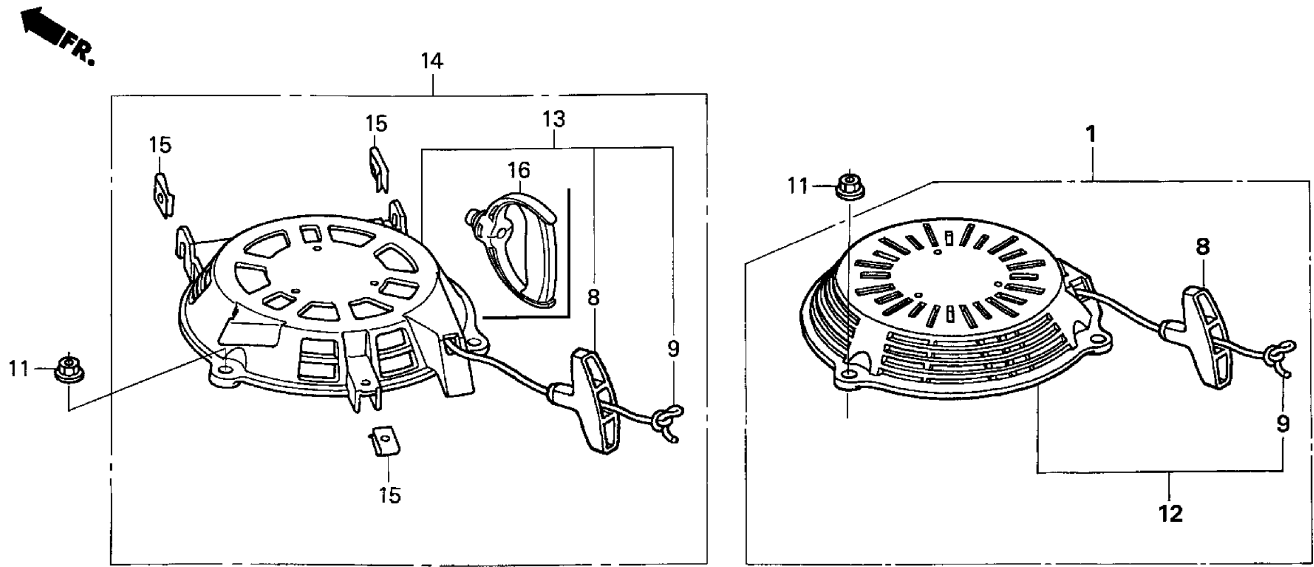

ZM00-E1100E

ZM00E1100E

MODEL
A =GCV160A

TYPE
a =S3H

E-11

Ref	Description	Engine Serial Number		QTY	Part Number	H/C
		From	To			
1	STARTER ASSY., RECOIL *NH1* (LONG ROPE) (BLACK)	-----	-----	1	28400-ZM0-633ZA	7839210
8	KNOB, RECOIL STARTER	-----	-----	1	28461-ZL8-003	5580634
9	ROPE, RECOIL STARTER (#3.5X90")	-----	-----	1	28462-ZL8-631	5580642
11	NUT, FLANGE (6MM).....	-----	-----	3	90201-ZM0-000	6478812

FAN COVER

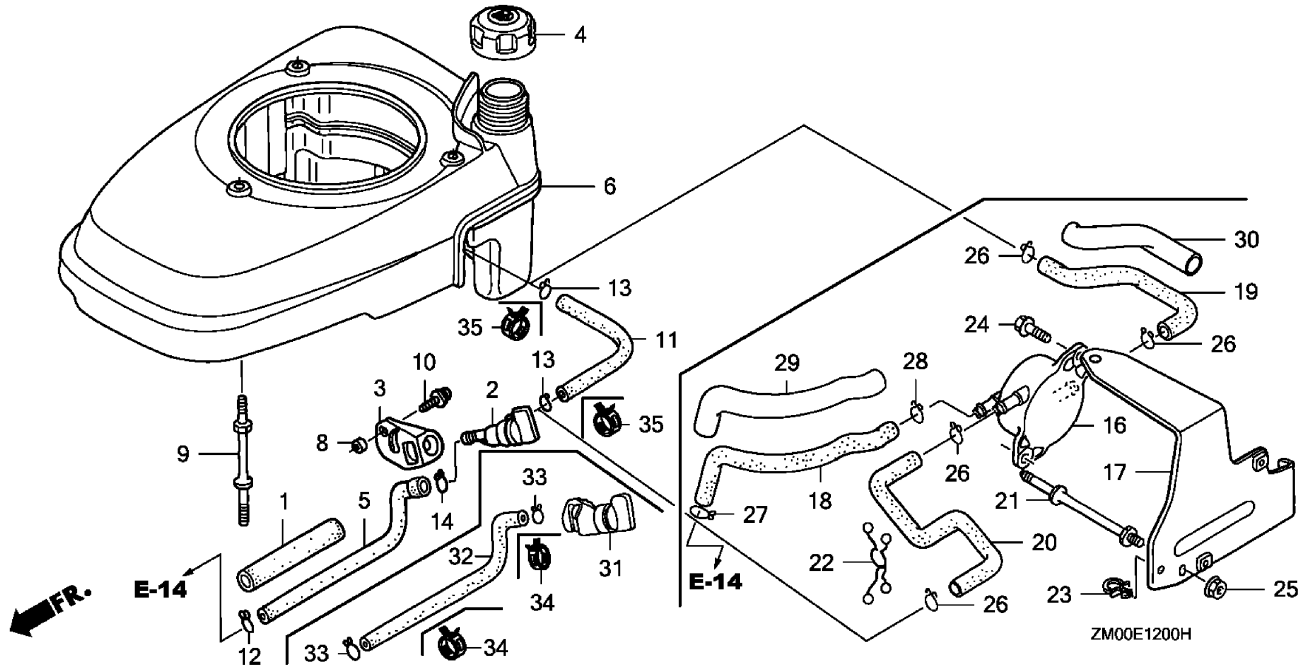

ZM00E1200H

MODEL
A =GCV160A

TYPE
a =S3H

E-12

Ref	Description	Engine Serial Number		QTY	Part Number	H/C
		From	To			
1	RUBBER, SUPPORTER (107MM)	-----	-----	1	16854-ZH8-000	3683646
4	CAP ASSY., FUEL TANK	-----	-----	1	17620-ZL8-013	6673289
6	COVER, FAN *NH1* (BLACK)	-----	-----	1	19610-Z0L-000ZA	6859680
	COVER, FAN *R280* (POWER RED)	-----	-----	1	19610-Z0L-000ZD	7299852
8	COLLAR, FUEL PETCOCK	-----	-----	1	91501-Z0L-800	6978399
9	BOLT, STUD.....	-----	-----	3	90043-ZL8-000	5581004
10	SCREW-WASHER (5X10)	-----	-----	1	93891-05010-08	0671636
11	BULK HOSE, FUEL (5.5X3000) (5.5X150)	-----	-----	1	95001-55003-60M	5338587
13	CLIP, TUBE (B10)	-----	-----	2	95002-02100	0250985
31	PETCOCK ASSY.....	-----	-----	1	16950-ZM0-003	7425770
32	TUBE, FUEL.....	-----	-----	1	17702-ZM0-800	7425804
33	CLIP, TUBE (B8)	-----	-----	2	95002-02080	0250647

CARBURETOR

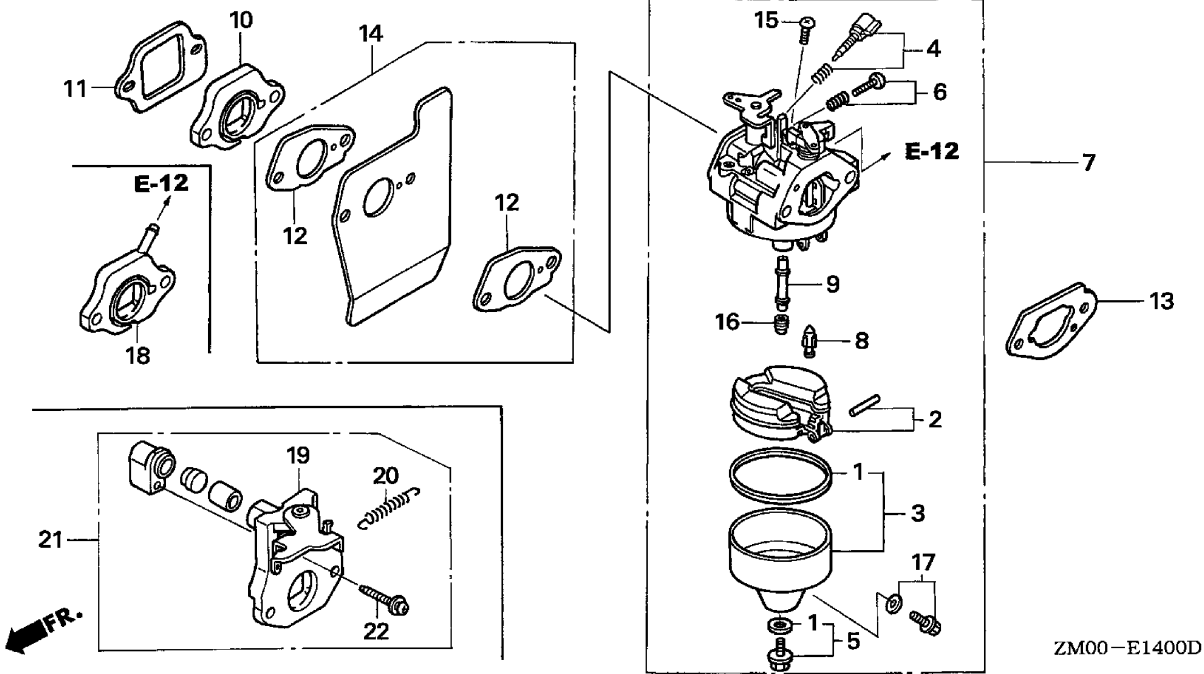

ZM00E1400D

MODEL
A =GCV160A

TYPE
a =S3H

E-14

Ref	Description	Engine Serial Number		QTY	Part Number	H/C
		From	To			
1	GASKET SET	-----	-----	1	16010-883-015	3088416
2	FLOAT SET	-----	-----	1	16013-ZL1-003	5580162
3	CHAMBER SET, FLOAT (CARBURETOR NO.).....	-----	-----	1	16015-887-782	3465879
5	SCREW SET B.....	-----	-----	1	16028-ZE0-005	1441518
7	CARBURETOR ASSY. (BB62S A).....	-----	-----	1	16100-Z0L-841	8018350
8	VALVE, FLOAT (CARBURETOR NO.).....	-----	-----	1	16155-ZM0-013	7934714
9	NOZZLE, MAIN.....	-----	-----	1	16166-Z0L-841	8018384
11	GASKET, INSULATOR.....	-----	-----	1	16212-ZL8-000	5580246
12	GASKET, CARBURETOR	-----	-----	2	16221-883-800	4581120
13	GASKET, CARBURETOR (CHOKE SIDE)	-----	-----	1	16228-Z0L-840	8018418
14	GUIDE, AIR	-----	-----	1	19650-ZM0-000	5580535
15	SCREW, PAN (5X6).....	-----	-----	1	93500-05006-0H	0639419
16	JET, MAIN (#65).....	-----	-----	(1)	99101-124-0650	0636126
	JET, MAIN (#68).....	-----	-----	(1)	99101-124-0680	0636134
	JET, MAIN (#70).....	-----	-----	1	99101-124-0700	0636142
17	SCREW SET, DRAIN (CARBURETOR NO.).....	-----	-----	1	16024-ZE1-811	1672187

CARBURETOR

MODEL **TYPE**
 A =GCV160A a =S3H

E-14

Ref	Description	Engine Serial Number		QTY	Part Number	H/C
		From	To			
19	INSULATOR	-----	-----	1	16210-Z0L-840	8018400
20	SPRING, CHOKE LEVER RETURN	-----	-----	1	16268-Z0L-840	8018426
21	CONTROL ASSY., CHOKE	-----	-----	1	16600-Z0L-840	7809916
22	SCREW-WASHER (4X35)	-----	-----	1	93891-04035-00	8019051

AIR CLEANER

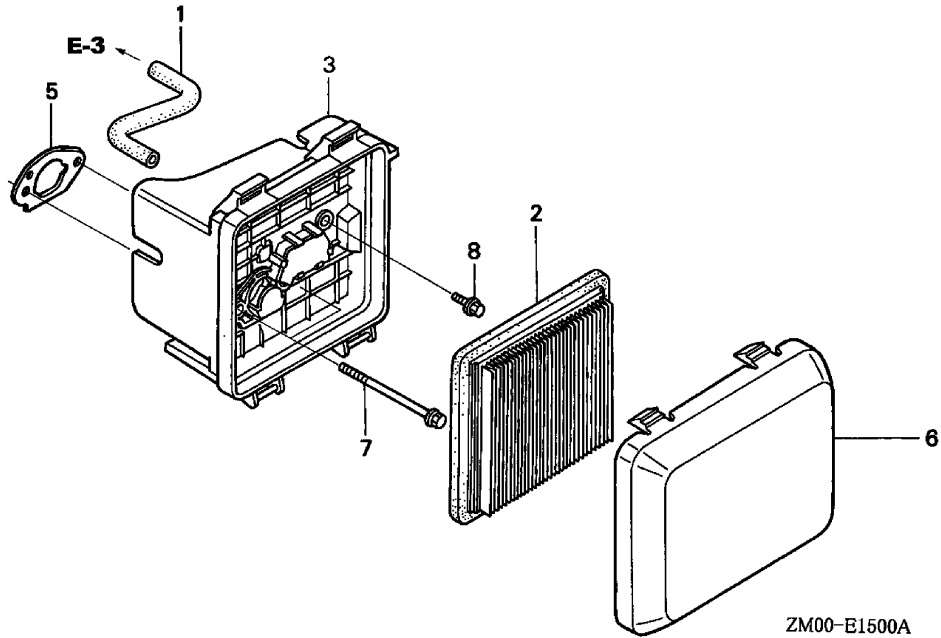

ZM00E1500A

MODEL
A =GCV160A

TYPE
a =S3H

E-15

Ref	Description	Engine Serial Number		QTY	Part Number	H/C
		From	To			
1	TUBE, BREATHER.....	-----	-----	1	15721-ZM0-000	5580154
2	ELEMENT, AIR CLEANER.....	-----	-----	1	17211-ZL8-023	8236440
3	CASE ASSY., AIR CLEANER	-----	-----	1	17220-ZM0-000	5580410
5	GASKET, AIR CLEANER.....	-----	-----	1	17228-ZM0-000	5664560
6	COVER, AIR CLEANER.....	-----	-----	1	17231-Z0L-030	7745011
7	BOLT, FLANGE (6X86) (CT200)	-----	-----	2	90003-ZM0-000	5580964
8	BOLT, FLANGE (6X14)	-----	-----	1	95701-06014-08	2374742

MUFFLER

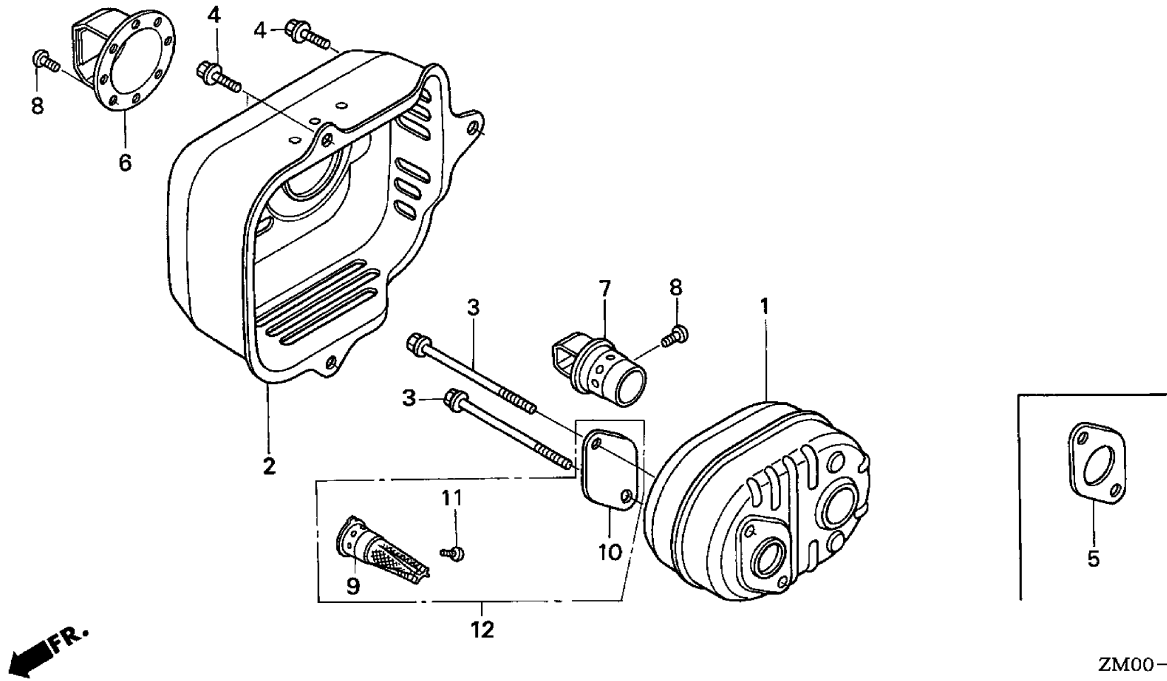

ZM00-E1600F

ZM00E1600F

MODEL
A =GCV160A

TYPE
a =S3H

E-16

Ref	Description	Engine Serial Number		QTY	Part Number	H/C
		From	To			
1	MUFFLER.....	-----	-----	1	18310-ZM0-000	5580485
2	PROTECTOR, MUFFLER (CBU).....	-----	-----	1	18321-Z0L-J00	7377062
3	BOLT, FLANGE (6X79) (CT200)	-----	-----	2	90004-ZL8-000	5580972
4	BOLT, FLANGE (6X12) (CT200)	-----	-----	3	90013-883-000	0636845
5	GASKET, MUFFLER	-----	-----	(1)	18381-ZL8-305	5737457
9	ARRESTER, SPARK	-----	-----	(1)	18350-ZL8-000	5656012
10	PLATE, ARRESTER NUMBER	-----	-----	(1)	18356-ZL8-000	5611397
11	SCREW, TAPPING (4X6).....	-----	-----	(1)	90055-ZE1-000	1431121
12	ARRESTER KIT, SPARK	-----	-----	(1)	06180-Z0J-000	8213597

FLYWHEEL (1)

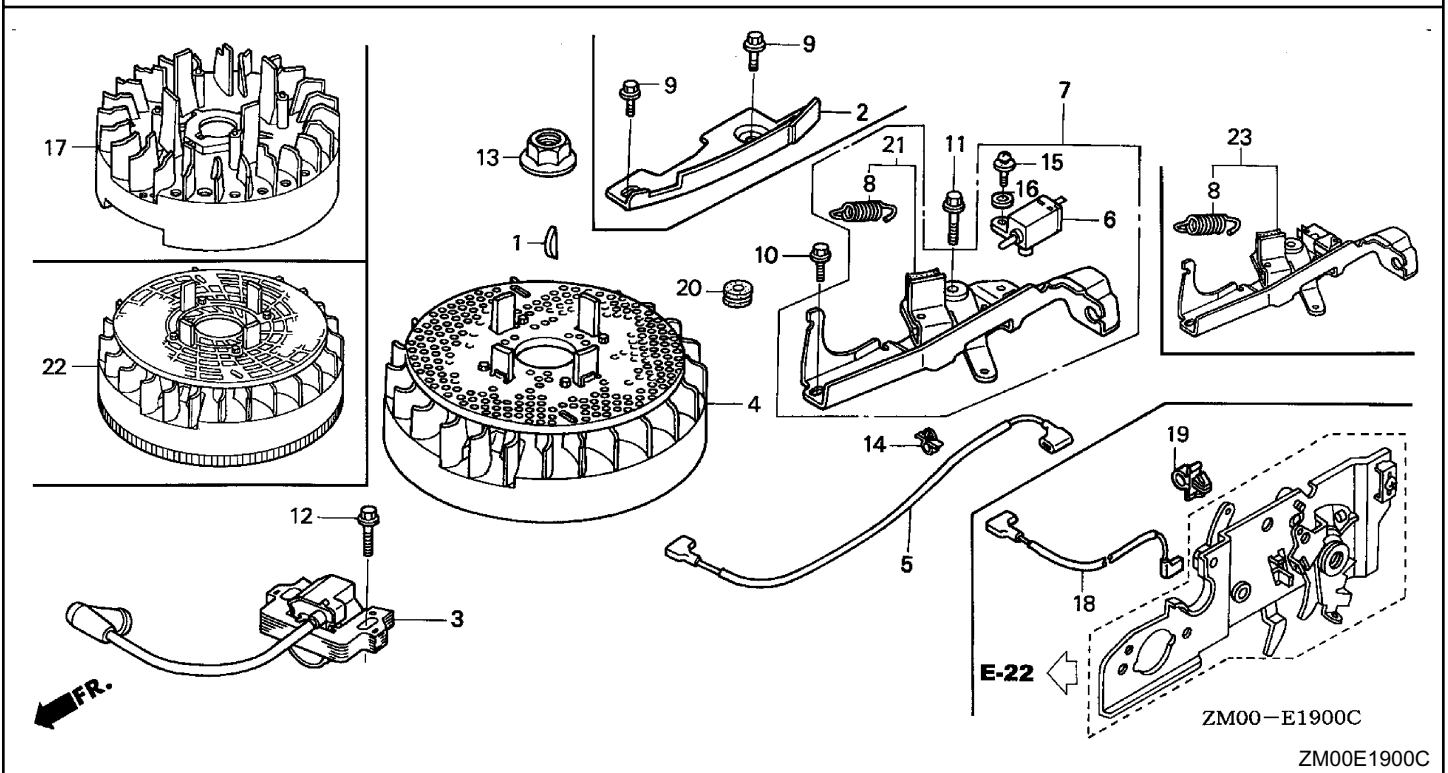

MODEL
A =GCV160A

TYPE
a =S3H

E-19

Ref	Description	Engine Serial Number		QTY	Part Number	H/C
		From	To			
1	KEY, SPECIAL WOODRUFF (25X18)	-----	-----	1	13331-357-000	0348433
3	COIL ASSY., IGNITION	-----	-----	1	30500-ZL8-004	5580659
4	FLYWHEEL ASSY.....	-----	-----	1	31105-ZM0-000	5580667
5	WIRE, STOP SWITCH	-----	-----	1	32195-Z0L-000	6859755
6	SWITCH ASSY., ENGINE STOP (N.C)	-----	-----	1	35120-ZM0-003	5580683
7	BRAKE ASSY.	-----	-----	1	75100-ZM0-000	5580782
8	SPRING, BRAKE LEVER.....	-----	-----	1	75113-ZM0-000	5580790
10	BOLT, FLANGE (6X14)	-----	-----	1	90014-952-000	0803619
11	BOLT, FLANGE (6X23)	-----	-----	1	90018-ZE1-000	1725050
12	BOLT, FLANGE (6X20) (CT200)	-----	-----	1	90022-888-010	0671552
13	NUT, SPECIAL (14MM)	-----	-----	1	90201-878-003	0442038
14	HOLDER, WIRE	-----	-----	1	51125-Z0L-003	7526155
	CLIP, CABLE (A)	-----	-----	1	90681-959-003	1824630
15	SCREW-WASHER (4X12)	-----	-----	1	93892-04012-00	0485946
16	WASHER, PLAIN (4MM)	-----	-----	1	94103-04000	1510361

CONTROL (3)

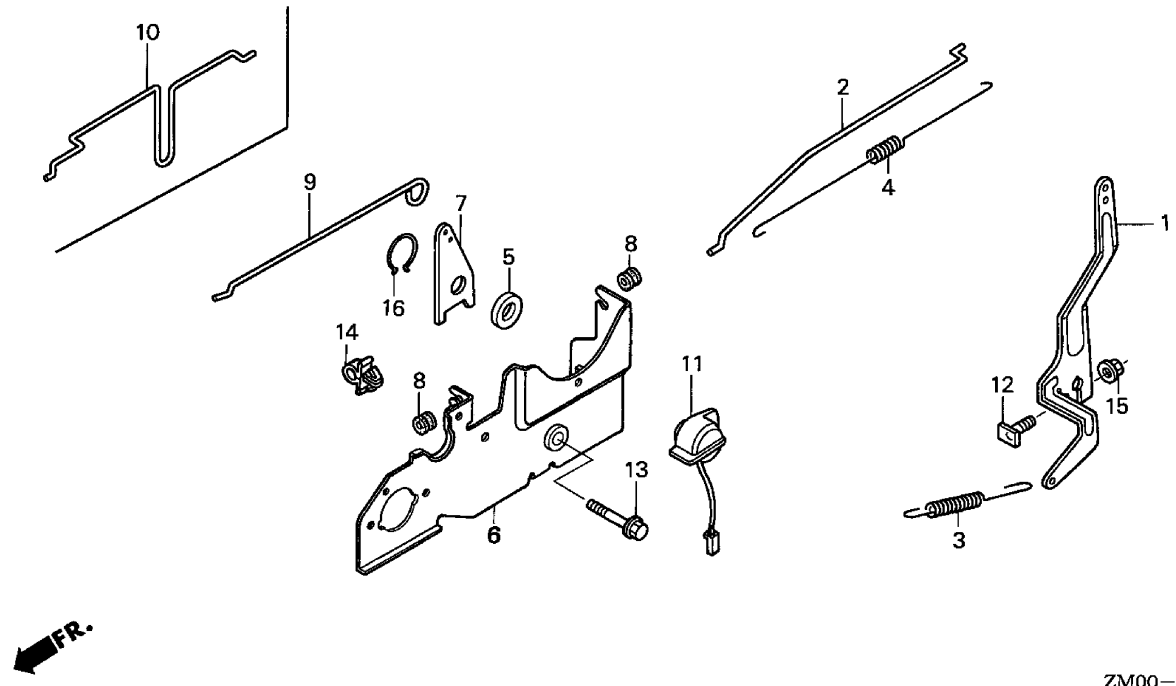

ZM00-E2202B

ZM00E2202B

MODEL
A =GCV160A

TYPE
a =S3H

E-22-2

Ref	Description	Engine Serial Number		QTY	Part Number	H/C
		From	To			
1	ARM, GOVERNOR.....	-----	-----	1	16551-ZM0-010	6869630
2	ROD, GOVERNOR.....	-----	-----	1	16555-Z0L-800	7229859
3	SPRING, GOVERNOR.....	-----	-----	1	16561-Z0L-000	7544224
4	SPRING, THROTTLE RETURN.....	-----	-----	1	16562-ZM0-000	5580352
6	BASE, CONTROL.....	-----	-----	1	16580-Z0L-810	6978415
12	BOLT, GOVERNOR ARM	-----	-----	1	90015-ZE5-010	2418671
13	BOLT, FLANGE (6X45)	-----	-----	1	90016-ZE8-000	2488187
15	NUT, FLANGE (6MM).....	-----	-----	1	94050-06000	0471623

For Discount Troy Bilt Parts Call 606-678-9623 or 606-561-4983

Part Number Index

PART NUMBER INDEX

Part Number	Grid	Page	Part Number	Grid	Page	Part Number	Grid	Page
(0)			16551-ZM0-010	1-C7	1-15	90015-ZE5-010	1-C7	1-15
06180-Z0J-000	1-C6	1-13	16555-Z0L-800	1-C7	1-15	90016-ZE8-000	1-C7	1-15
(1)			16561-Z0L-000	1-C7	1-15	90018-ZE1-000	1-C7	1-14
11300-ZM0-405	1-C1	1-3	16562-ZM0-000	1-C7	1-15	90022-888-010	1-C7	1-14
11300-ZM0-811	1-C1	1-3	16580-Z0L-810	1-C7	1-15	90043-ZL8-000	1-C4	1-9
12000-Z0L-406	1-C1	1-2	16600-Z0L-840	1-C5	1-11	90055-ZE1-000	1-C6	1-13
12209-ZM0-003	1-C3	1-7	16854-ZH8-000	1-C4	1-9	90121-952-000	1-C1	1-3
12311-ZL8-000	1-C1	1-2	16950-ZM0-003	1-C4	1-9	90201-878-003	1-C7	1-14
12311-ZL8-D00	1-C1	1-2	17211-ZL8-023	1-C6	1-12	90201-ZM0-000	1-C4	1-8
12355-ZL8-000	1-C1	1-2	17220-ZM0-000	1-C6	1-12	90206-001-000	1-C3	1-7
13010-Z0L-003	1-C3	1-6	17228-ZM0-000	1-C6	1-12	90402-ZL8-000	1-C2	1-5
13010-Z0L-004	1-C3	1-6	17231-Z0L-030	1-C6	1-12	90451-ZE1-000	1-C1	1-3
13101-Z2A-000	1-C3	1-6	17620-ZL8-013	1-C4	1-9	90551-ZE0-000	1-C3	1-6
13111-ZE0-000	1-C3	1-6	17702-ZM0-800	1-C4	1-9	90602-ZE1-000	1-C1	1-3
13200-ZL8-000	1-C3	1-6	18310-ZM0-000	1-C6	1-13	90681-959-003	1-C7	1-14
13310-ZM0-610	1-C2	1-5	18321-Z0L-J00	1-C6	1-13	91201-ZL8-003	1-C1	1-2
13331-357-000	1-C7	1-14	18350-ZL8-000	1-C6	1-13	91202-ZL8-003	1-C1	1-3
14320-ZL8-010	1-C3	1-7	18356-ZL8-000	1-C6	1-13	91301-ZM0-V31	1-C3	1-7
14324-ZL8-000	1-C3	1-7	18381-ZL8-305	1-C6	1-13	91356-MA6-005	1-C2	1-4
14400-Z0J-014	1-C3	1-7	19610-Z0L-000ZA	1-C4	1-9	91501-Z0L-800	1-C4	1-9
14431-Z0J-000	1-C3	1-7	19610-Z0L-000ZD	1-C4	1-9	93500-05006-0H	1-C5	1-10
14441-Z0J-000	1-C3	1-7	19650-ZM0-000	1-C5	1-10	93891-04035-00	1-C5	1-11
14461-ZL8-000	1-C3	1-7	(2)			93891-05010-08	1-C4	1-9
14711-Z0J-000	1-C3	1-7	28400-ZM0-633ZA	1-C4	1-8	93892-04012-00	1-C7	1-14
14721-ZL8-000	1-C3	1-7	28461-ZL8-003	1-C4	1-8	94050-06000	1-C7	1-15
14751-ZL8-000	1-C3	1-7	28462-ZL8-631	1-C4	1-8	94101-06800	1-C2	1-4
14771-Z0J-000	1-C3	1-7	(3)			94103-04000	1-C7	1-14
15625-ZE6-000	1-C1	1-3	30500-ZL8-004	1-C7	1-14	94251-08000	1-C2	1-4
15631-ZM0-000	1-C1	1-3	31105-ZM0-000	1-C7	1-14	94301-08200	1-C2	1-4
15639-ZM0-000	1-C1	1-3	32195-Z0L-000	1-C7	1-14	95001-55003-60M	1-C4	1-9
15650-ZM0-801	1-C1	1-3	35120-ZM0-003	1-C7	1-14	95002-02080	1-C4	1-9
15721-ZM0-000	1-C6	1-12	(4)			95002-02100	1-C4	1-9
16010-883-015	1-C5	1-10	51125-Z0L-003	1-C7	1-14	95701-06014-08	1-C6	1-12
16013-ZL1-003	1-C5	1-10	(5)			98079-56846	1-C1	1-2
16015-887-782	1-C5	1-10	75100-ZM0-000	1-C7	1-14	99101-124-0650	1-C5	1-10
16024-ZE1-811	1-C5	1-10	75113-ZM0-000	1-C7	1-14	99101-124-0680	1-C5	1-10
16028-ZE0-005	1-C5	1-10	(6)			99101-124-0700	1-C5	1-10
16100-Z0L-841	1-C5	1-10	90001-ZE1-000	1-C3	1-6			
16155-ZM0-013	1-C5	1-10	90003-ZM0-000	1-C6	1-12			
16166-Z0L-841	1-C5	1-10	90004-ZL8-000	1-C6	1-13			
16210-Z0L-840	1-C5	1-11	90012-333-000	1-C3	1-7			
16212-ZL8-000	1-C5	1-10	90013-883-000	1-C1	1-2			
16221-883-800	1-C5	1-10		1-C6	1-13			
16228-Z0L-840	1-C5	1-10	90014-952-000	1-C1	1-2			
16268-Z0L-840	1-C5	1-11		1-C1	1-3			
16508-ZM0-010	1-C1	1-3		1-C7	1-14			
16510-ZM0-010	1-C1	1-3						
16511-ZL8-000	1-C1	1-3						
16512-ZM0-000	1-C1	1-3						
16513-ZE1-000	1-C1	1-3						
16531-ZE1-000	1-C1	1-3						
16541-ZM0-000	1-C1	1-3						

Description Index

DESCRIPTION INDEX

Description	Grid	Page	Ref	Description	Grid	Page	Ref
(A)				(D)			
ARM, EX. VALVE ROCKER	1-C3	1-7	16	DIPSTICK, OIL	1-C1	1-3	2
ARM, GOVERNOR	1-C7	1-15	1	(E)			
ARM, IN. VALVE ROCKER	1-C3	1-7	15	ELEMENT, AIR CLEANER	1-C6	1-12	2
ARRESTER KIT, SPARK	1-C6	1-13	12	EXTENSION, OIL FILLER	1-C1	1-3	5
ARRESTER, SPARK	1-C6	1-13	9	(F)			
(B)				(G)			
BASE, CONTROL	1-C7	1-15	6	FLOAT SET	1-C5	1-10	2
BELT, TIMING (84HU7 G-200)	1-C3	1-7	3	FLYWHEEL ASSY.....	1-C7	1-14	4
BOLT, CONNECTING ROD	1-C3	1-6	4	(H)			
BOLT, FLANGE (6X12) (CT200)	1-C1	1-2	5	GASKET SET	1-C5	1-10	1
	1-C6	1-13	4	GASKET, AIR CLEANER	1-C6	1-12	5
BOLT, FLANGE (6X14)	1-C1	1-2	6	GASKET, CARBURETOR	1-C5	1-10	12
	1-C1	1-3	15	GASKET, CARBURETOR (CHOKE SIDE)	1-C5	1-10	13
	1-C6	1-12	8	GASKET, INSULATOR	1-C5	1-10	11
	1-C7	1-14	10	GASKET, MUFFLER	1-C6	1-13	5
BOLT, FLANGE (6X20) (CT200)	1-C7	1-14	12	GASKET, OIL FILLER CAP	1-C1	1-3	4
BOLT, FLANGE (6X23)	1-C7	1-14	11	GOVERNOR ASSY.	1-C1	1-3	9
BOLT, FLANGE (6X25)	1-C1	1-3	16	GUIDE, AIR	1-C5	1-10	14
BOLT, FLANGE (6X45)	1-C7	1-15	13	(I)			
BOLT, FLANGE (6X79) (CT200)	1-C6	1-13	3	INSULATOR	1-C5	1-11	19
BOLT, FLANGE (6X86) (CT200)	1-C6	1-12	7	(J)			
BOLT, GOVERNOR ARM	1-C7	1-15	12	JET, MAIN (#65)	1-C5	1-10	16
BOLT, STUD	1-C4	1-9	9	JET, MAIN (#68)	1-C5	1-10	16
BRAKE ASSY.	1-C7	1-14	7	JET, MAIN (#70)	1-C5	1-10	16
BULK HOSE, FUEL (5.5X3000) (5.5X150)	1-C4	1-9	11	(K)			
(C)				(M)			
CAP ASSY., FUEL TANK	1-C4	1-9	4	MUFFLER.....	1-C6	1-13	1
CARBURETOR ASSY. (BB62S A)	1-C5	1-10	7	(N)			
CASE ASSY., AIR CLEANER	1-C6	1-12	3	NOZZLE, MAIN	1-C5	1-10	9
CHAMBER SET, FLOAT	1-C5	1-10	3	NUT, FLANGE (6MM)	1-C4	1-8	11
CLIP, CABLE (A)	1-C7	1-14	14		1-C7	1-15	15
CLIP, GOVERNOR HOLDER	1-C1	1-3	18	(L)			
CLIP, PISTON PIN (13MM)	1-C3	1-6	5	(O)			
CLIP, TUBE (B10)	1-C4	1-9	13	(P)			
CLIP, TUBE (B8)	1-C4	1-9	33	(Q)			
COIL ASSY., IGNITION	1-C7	1-14	3	(R)			
COLLAR, FUEL PETCOCK	1-C4	1-9	8	(S)			
CONTROL ASSY., CHOKE	1-C5	1-11	21	(T)			
COVER, AIR CLEANER	1-C6	1-12	6	(U)			
COVER, BREATHER	1-C1	1-2	4	(V)			
COVER, FAN *NH1* (BLACK)	1-C4	1-9	6	(W)			
COVER, FAN *R280* (POWER RED)	1-C4	1-9	6	(X)			
COVER, HEAD	1-C1	1-2	3	(Y)			
CRANKSHAFT (N3-TYPE)	1-C2	1-5	3	(Z)			
CYLINDER ASSY.	1-C1	1-2	1	(AA)			

DESCRIPTION INDEX

Description	Grid	Page	Ref	Description	Grid	Page	Ref
NUT, SPECIAL (14MM)	1-C7	1-14	13	SPRING, VALVE	1-C3	1-7	9
NUT, TAPPET ADJ.	1-C3	1-7	12	STARTER ASSY., RECOIL *NH1* (LONG ROPE) (BLACK)	1-C4	1-8	1
(O)				SWITCH ASSY., ENGINE STOP (N.C)	1-C7	1-14	6
O-RING (14.8X2.4) (NOK)	1-C2	1-4	20	(T)			
O-RING (6.8X1.9)	1-C3	1-7	13	TUBE, BREATHER	1-C6	1-12	1
OIL SEAL (25.4X62X6)	1-C1	1-2	7	TUBE, FUEL	1-C4	1-9	32
OIL SEAL (28X41.25X6)	1-C1	1-3	19	(V)			
(P)				VALVE, EX.	1-C3	1-7	8
PAN ASSY., OIL	1-C1	1-3	1	VALVE, FLOAT	1-C5	1-10	8
PAN ASSY., OIL (000)	1-C1	1-3	1	VALVE, IN.	1-C3	1-7	7
PETCOCK ASSY.	1-C4	1-9	31	(W)			
PIN, DOWEL (8X20)	1-C2	1-4	23	WASHER, EXTENSION LOCK	1-C1	1-3	6
PIN, GOVERNOR WEIGHT	1-C1	1-3	12	WASHER, PLAIN (4MM)	1-C7	1-14	16
PIN, LOCK (8MM)	1-C2	1-4	22	WASHER, PLAIN (6MM)	1-C2	1-4	21
PIN, PISTON	1-C3	1-6	2	WASHER, THRUST	1-C2	1-5	5
PISTON	1-C3	1-6	1	WASHER, THRUST (6MM)	1-C1	1-3	17
PLATE, ARRESTER NUMBER	1-C6	1-13	10	WEIGHT, GOVERNOR	1-C1	1-3	10
PROTECTOR, MUFFLER (CBU)	1-C6	1-13	2	WIRE, STOP SWITCH	1-C7	1-14	5
PULLEY, CAMSHAFT	1-C3	1-7	1				
(R)							
RETAINER, VALVE SPRING	1-C3	1-7	10				
RING SET, PISTON (RIKEN)	1-C3	1-6	6				
RING SET, PISTON (TEIKOKU)	1-C3	1-6	6				
ROD ASSY., CONNECTING	1-C3	1-6	3				
ROD, GOVERNOR	1-C7	1-15	2				
ROPE, RECOIL STARTER (#3.5X90")	1-C4	1-8	9				
RUBBER, SUPPORTER (107MM)	1-C4	1-9	1				
(S)							
SCREW SET B	1-C5	1-10	5				
SCREW SET, DRAIN	1-C5	1-10	17				
SCREW, PAN (5X6)	1-C5	1-10	15				
SCREW, TAPPET ADJ.	1-C3	1-7	11				
SCREW, TAPPING (4X6)	1-C6	1-13	11				
SCREW-WASHER (4X12)	1-C7	1-14	15				
SCREW-WASHER (4X35)	1-C5	1-11	22				
SCREW-WASHER (5X10)	1-C4	1-9	10				
SEAL, VALVE STEM	1-C3	1-7	14				
SHAFT, CAM PULLEY	1-C3	1-7	2				
SHAFT, GOVERNOR ARM	1-C1	1-3	14				
SHAFT, GOVERNOR HOLDER	1-C1	1-3	8				
SHAFT, ROCKER ARM	1-C3	1-7	6				
SLIDER, GOVERNOR	1-C1	1-3	13				
SPARK PLUG (BPR6ES) (NGK)	1-C1	1-2	8				
SPRING, BRAKE LEVER	1-C7	1-14	8				
SPRING, CHOKE LEVER RETURN	1-C5	1-11	20				
SPRING, GOVERNOR	1-C7	1-15	3				
SPRING, THROTTLE RETURN	1-C7	1-15	4				