

MASTER PARTS CATALOG

for the

HORSE MODEL

TROY-BILT® Roto Tiller-Power Composter

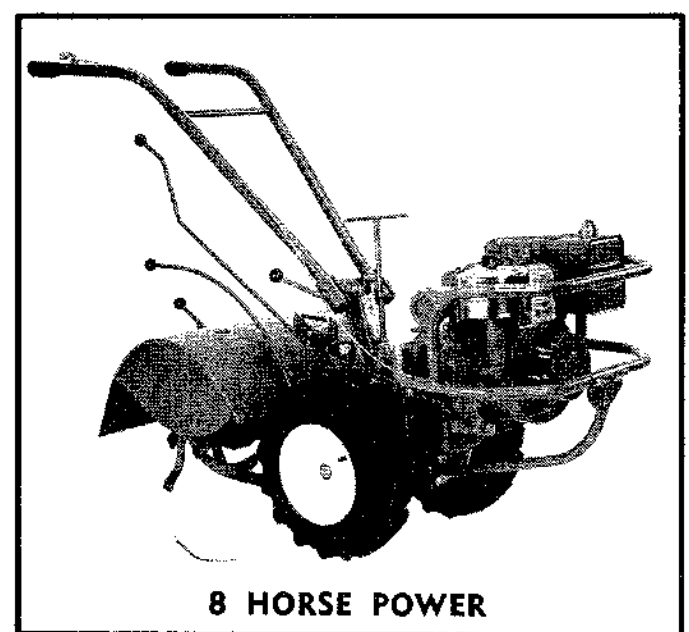
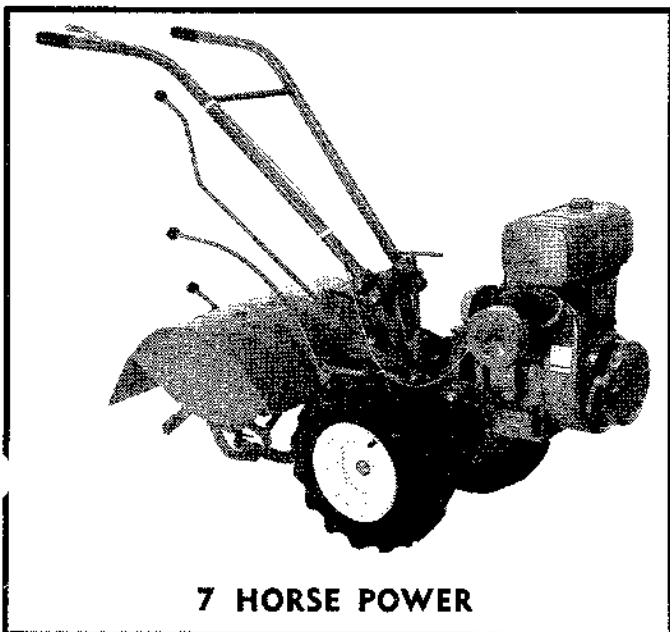
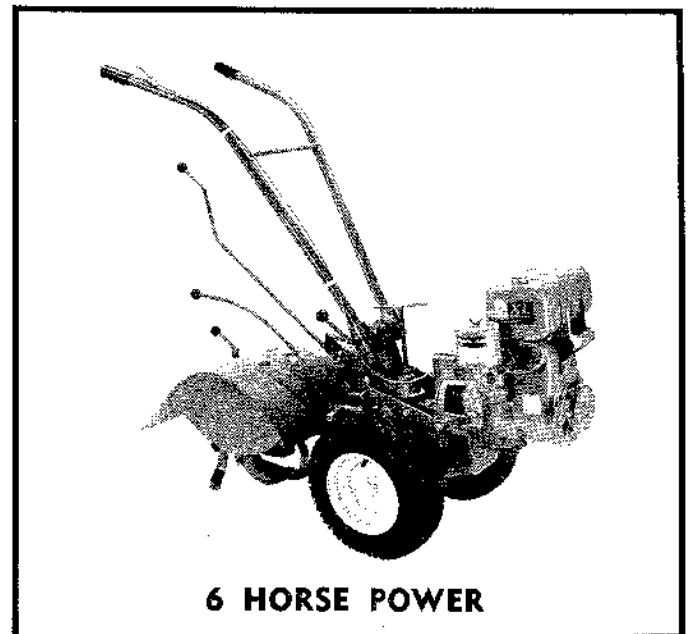
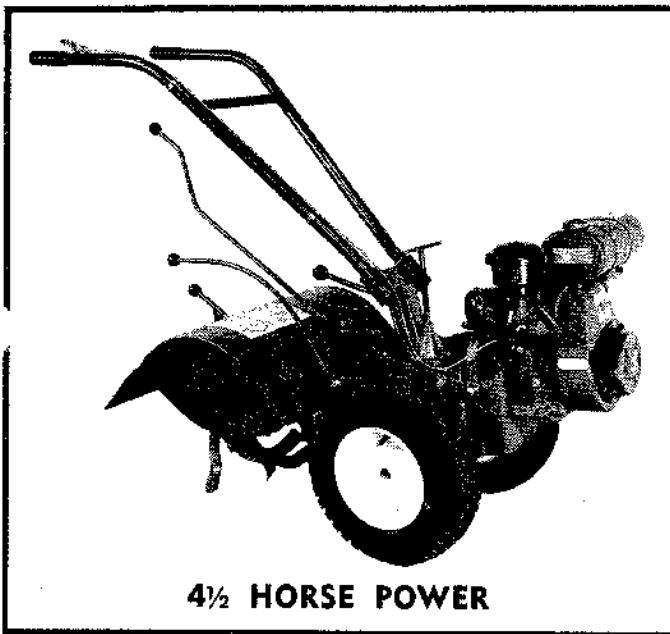

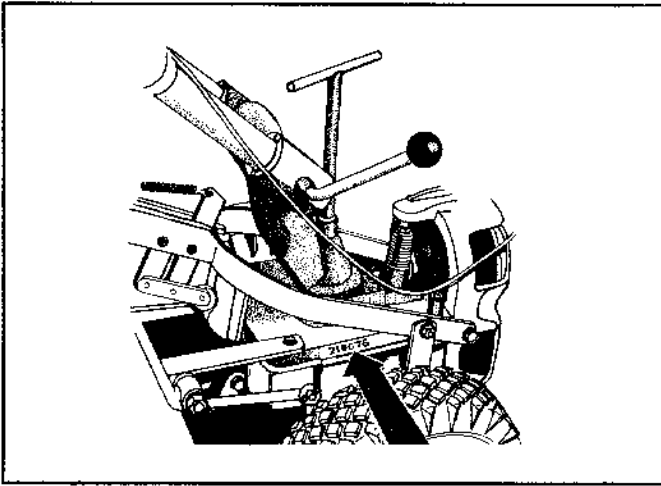

LOOK HERE

On Tillers shipped after 7/5/71, look on the Transmission Case, Part No. 1000, right side above wheel axle.

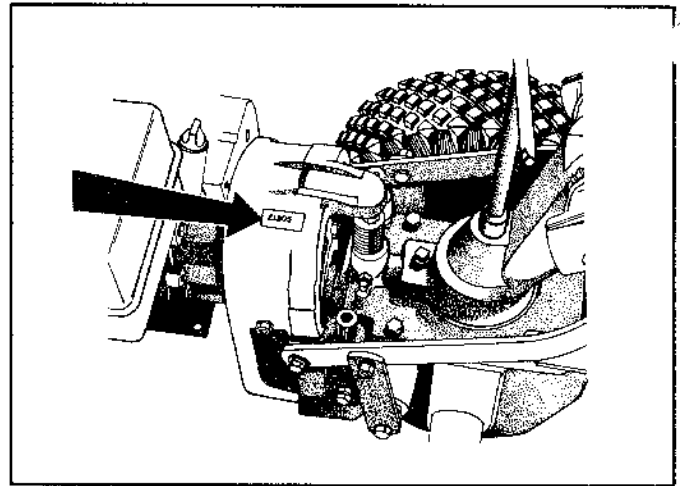

OR HERE

On Tillers shipped on or before 7/5/71, look on Motor Mount, Part No. 1002, top left.

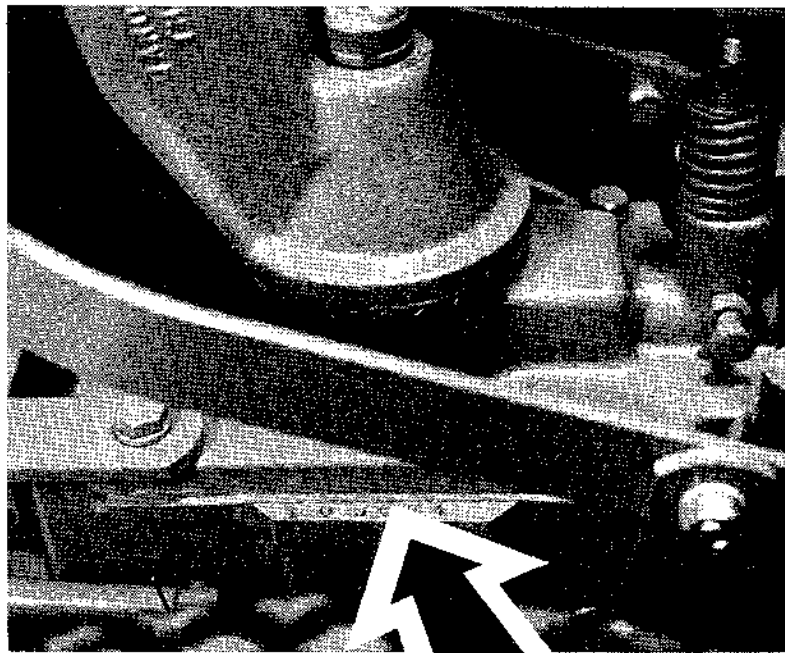

Here's A Closeup Look . . . at the tiller serial number on the transmission case, about 4½ inches above the wheel axle on the right side.

(RECORD YOUR TILLER SERIAL NUMBER HERE)

EXPLANATION OF "RIGHT HAND" & "LEFT HAND"

Right Hand or Left Hand are determined by standing in the operator position and facing the direction of forward travel.

How To Order Tiller Parts

To order replacement parts for your tiller, look up the Part No. in this Catalog. Then call or write our Parts Department, giving your tiller's Serial No., the Part No., and the quantity desired. Pre-payment is not necessary unless the total order is a substantial amount.

All engine parts should be ordered from your local authorized engine dealer as we do not stock engine parts. Also, there is a \$3.00 minimum charge for tiller parts (non-engine parts), plus postage. Therefore, if you need just a common bolt or washer, you'll save money by obtaining that part locally.

IN THE U.S.A.

GARDEN WAY MANUFACTURING COMPANY
102nd St. & 9th Ave., Troy, NY 12180
call Toll-Free: 1-800-833-6990

IN CANADA

1515 Matheson Blvd. E., Unit B11, Mississauga, Ontario L4W 2P5
call Toll-Free: 1-800-225-3585

PLEASE NOTE

Illustrations used in this Catalog do not necessarily show the exact shapes and relative sizes of tiller parts and attachments. These illustrations should be used only as a helpful guide to identify the basic shape of the part or attachment, and its location in relation to other parts or attachments.

By the same token, a few special parts that we must purchase rather than manufacture ourselves, may vary slightly in shape, color, or texture from the original part. This is due to the fact that certain parts are supplied to us by more than one manufacturer. Please be assured, however, that all of these special parts must conform to our rigid quality specifications, and any slight variations will not affect the fit or performance of these parts.

Table of Contents

TILLER ASSEMBLIES BY GROUPS	pages 4 thru 39
Locating Tiller Serial Number	inside front cover
Locating Engine Model & Specification Numbers	page 28
How To Order Tiller Parts	page 1
How To Use This Catalog	page 3
TRANSMISSION ASSEMBLIES	pages 4-13
Drive Shaft Assembly	page 5
Wheel Shaft Assembly	pages 5 & 6
Pinion Shaft Assembly	pages 5 & 6
Tiller Shaft Assembly	page 6
Transmission Cover, Neutral Spring & Plunger	page 7
Transmission Housing, Plugs & Roll Pins	page 7
Earlier Drive Shafts	pages 8 & 9
Wheel Gear Combinations & Wheel/Tine Ratios	page 10
Shafts & Gears — Relative Positions & Functions	page 11
Seals, Covers, Gaskets & Pipe Plugs	page 12
TILLER, TINES, HOOD, WHEELS, DEPTH REGULATOR	pages 14-19
Depth Regulator	pages 14 & 15
Lower Pulley (Transmission Drive)	page 14
Belt Adjustment Block	page 14
Hood Brackets	page 14
Wheel Options	pages 16 & 17
Wheels, 4:80 x 8, Standard	page 14
Wheels, 4:80 x 8, Bar Tread	page 16
Wheels, 4:00 x 7, Standard, Prior to 1972	page 16
Bolo Tine Assembly	page 18
ENGINE & MOUNT, PULLEY, BELTS, HANDLEBARS & SHIFT LEVERS	pages 20-33
Motor Mount	page 22
Engine Pulley	page 22
Belts	pages 20 & 22
Clutch Lever	page 22
Speed Shift Lever (Wheel)	pages 22 & 24
Knobs for Levers	page 22
Handlebars	page 22
Handlebar Adjustments	page 22
Reverse Disc	pages 20 & 22
Clutch Yoke	pages 20 & 22
Engine Options	pages 26 & 27
Engine Model & Specification Numbers	page 27
Electric Start Diagrams, 6 HP & 8 HP Engines	pages 28-33
Battery, Mounting Bracket, Wires, Solenoid	pages 28-33
TILLER ATTACHMENTS	pages 34-39
Hiller/Furrower	page 34
Dozer/Snow Blade	pages 36-37, 39
Bumper	page 36
Row Marker	page 38
Sod Point	page 39
NON-CURRENT PARTS	pages 40 & 41
NUMERICAL INDEX	pages 42-44

Helpful Information

FOR USERS OF THE HORSE MODEL MASTER PARTS CATALOG

This Master Parts Catalog only covers the Horse Model TROY-BILT Roto Tiller-Power Composter, built by Garden Way Manufacturing Co. THE CATALOG REPLACES ALL OTHER HORSE MODEL PARTS LISTS PREVIOUSLY ISSUED.

Garden Way Manufacturing Co. will always pay careful attention to every parts order or service request. This catalog is a part of our policy of "Trying to be of genuine service to our customers." Please look it over occasionally and get to know it. We think it will be of help to you.

If you have any unanswered questions, please write to us, or call if it is urgent. We'll give you all the help we can. Most people find our help is more than sufficient.

HOW TO USE THIS CATALOG

Below, you will see a portion of a sample page in this catalog, similar to those parts lists opposite the drawings. To find a part, locate the page number of the assembly drawing of the part you seek in the Table of Contents. Some parts may be shown on more than one drawing.

Each illustrated part has an Index Number. This Index Number appears in the first column of the parts list. The second column of the parts list shows the part number given to that particular part. The part numbers in the second column should be used to order replacement parts.

The third column of the parts list generally uses a single word to describe the part, then gives further information. Where we think it will be extra

helpful to you, we have often identified where it fits, or what it does in the assembly.

The fourth column of the parts list shows how many of each part is used in the illustrated assembly. If a part is used more than once on the tiller, you can determine how many and where by looking at the Numerical Index of parts in the back of the catalog. This shows the page and index numbers of all the assemblies using that part.

On the sample parts list page below, the last column shows whether or not a part has replaced an earlier part number. Sometimes it reflects a simple number change, or an improvement in design or materials. In these instances, parts are interchangeable unless otherwise noted. Where there are several related parts replaced in an assembly brought about by design improvements, the "REPLACES" column will refer you to a note which will list all of the parts included in that change.

On page 39 of this catalog, there is a list of Non-Current Parts that have been dropped in the course of design improvements. Many of these parts are no longer available (they are usually quite old parts). But, where you need to know what part to use in its place, the list shows a page number and an Index Number to locate the replacement part.

In the back of this catalog, is a numerical listing of part numbers. Each part number refers you to a page and an Index Number on the drawing or photo. Thus, if you know the part number but do not know its name, location, or use, the list will refer directly to the proper drawing and part description.

INDEX NO.	PART NO.	DESCRIPTION	NO. REQ'D	REPLACES
TRANSMISSION HOUSING, PLUGS & ROLL PINS				
68	9726	PLUG—pipe 1/4", oil, and clutch fork shaft Index 34	3	1130
69	9307	PIN—roll (spiral) 3/16" x 1/4" eccentric lever index 36	1	
70	9122	PLUG—protective plastic red, protect threads for Dozer Blade mounting bracket	1	1217

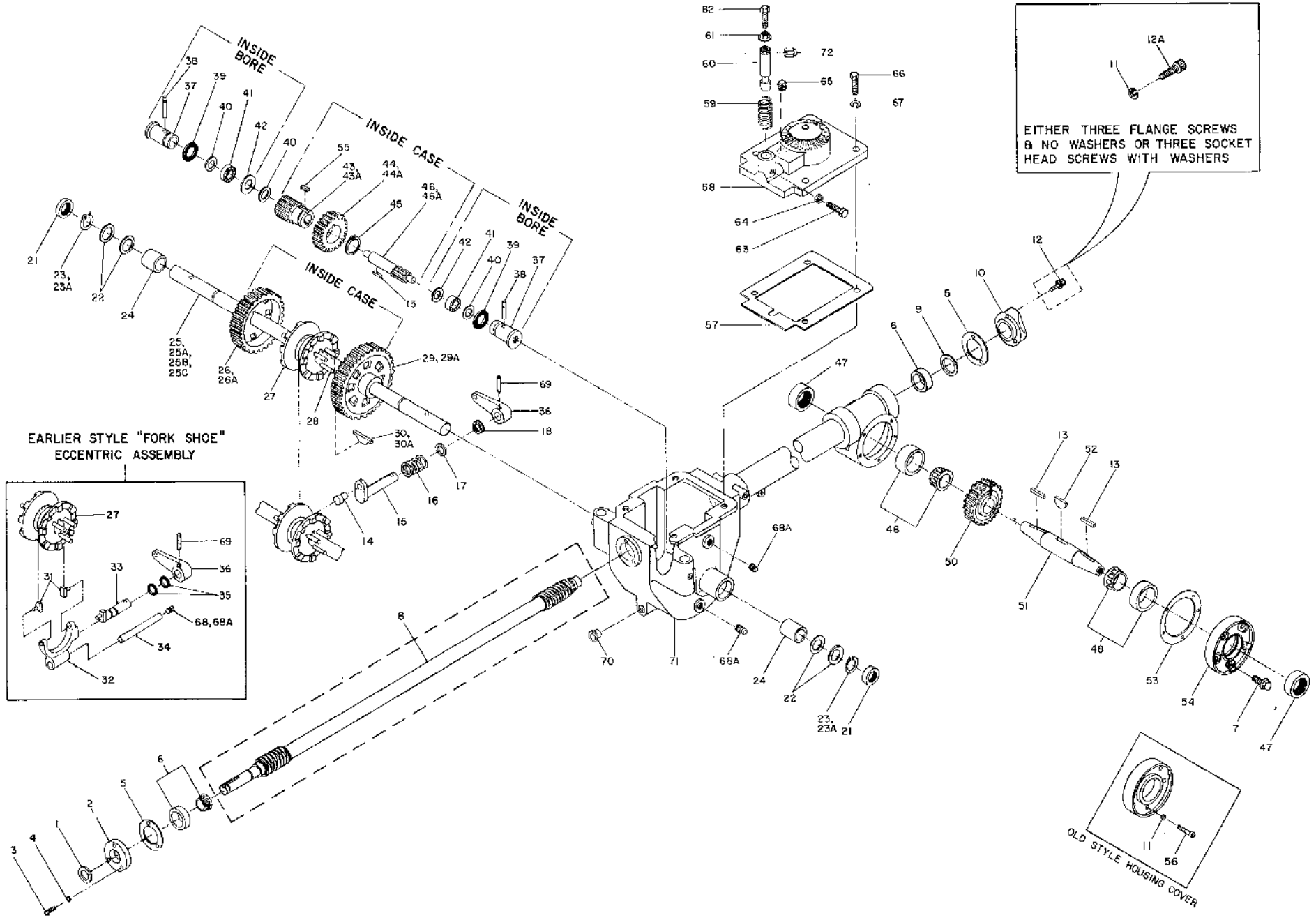

Transmission Assemblies

INDEX NO.	PART NO.	DESCRIPTION	NO. REQ'D	REPLACES
DRIVE SHAFT ASSEMBLY				
1	9600	SEAL—oil, drive shaft, front	1	1090
2	1114	CAP—front bearing, drive shaft	1
3	9701	SCREW—hex. hd. 1/4"-20 x 3/4"	3
4	9910	LOCKWASHER—1/4"	3
5	1124-2	GASKET—front and rear bearing caps	2	1124
6	1714	TAPERED BEARING & CUP—cone roller bearing with cup (race), front & rear, drive shaft. Cones and cups are not available separately	2	9400, 9401
7	9780	SCREW—hex. hd., flanged, self-locking, 1/4"-20 x 5/8". Use with new-style #1872 cover (Index No. 54). Not interchangeable with #9718 screw (Index No. 56)	5	9718
8	1902	SHAFT—main drive, 3/4", welded single piece, includes front & rear worm gears and pressed-on rear cone bearing with cup. First used in tillers made on March 5, 1979. NOTE: Occasionally substituted by assembled style shaft, see Pages 8 & 9 to identify your shaft	1	1024, 1268, 1550
9	1224-1	SHIM—rear bearing cap, 1 1/2" I.D., thickness 0.010"	as req'd
"	1224-2	SHIM—SAME AS ABOVE, thickness 0.030"	Same
"	1224-3	SHIM—SAME AS ABOVE, thickness 0.005"	Same
10	1115	CAP—rear bearing	1
11	9911	LOCKWASHER—Hi-collar, 1/4", use with #9718 & #9719 screws	as req'd	1209
12	9773	SCREW—hex. hd., flanged, self-locking, 1/4"-20 x 7/8" (use without lock-washer) not interchangeable with #9719 socket hd. screw	3	9719
12A	9719	SCREW—Socket hd., 1/4"-20 x 1" (use with #9911 lockwasher). Not interchangeable with #9773 flanged screw	3	1210
WHEEL SHAFT ASSEMBLY				
14	1442	PIN—clutch shifting, single pin eccentric, for Tiller Serial No. 493014 & Up	1	1094
15	1568	ECCENTRIC SHAFT—single pin assembly, for Tiller Serial No. 493014 & Up	1	1027A
16	1441	SPRING—single pin eccentric shaft, for Tiller Serial No. 493014 & Up	1
17	1440	WASHER—single pin eccentric shaft, for Tiller Serial No. 493014 & Up	1
18	9611	SEAL—oil, single pin eccentric, for Tiller Serial No. 493014 & Up	1	9603
21	9609	SEAL—oil, wheel shaft	2	1091, 9601
22	1166-1	SHIM—wheel shaft, 1-1/64" I.D., 0.062" (1/16") thickness	as req'd	1166
"	1166-2	SHIM—SAME AS ABOVE, 0.030" thickness	as req'd	"
"	1166-3	SHIM—SAME AS ABOVE, 0.015" thickness	as req'd	"
"	1166-4	SHIM—SAME AS ABOVE, 0.010" thickness	as req'd	"
"	1166-5	SHIM—SAME AS ABOVE, 0.005" thickness	as req'd	"
23	9511	RING—retaining (snap ring, external), wheel shaft, inside bore. Heavy-duty ring for No's. 1878 & 1879 shafts (Index No's. 25 & 25B)	2	9501, 1110
23A	9501	RING—retaining (snap ring, external), wheel shaft, inside bore. Use with No's. 1235A & 1025 shafts (Index No's. 25A & 25C)	2	1110
24	1086	BUSHING—bronze, wheel shaft bearing	2
25	1878	SHAFT—wheel, 1 5/8", for tiller serial No. 31456 & Up (first used with serial No. 600009). Includes Hi-Pro Key (Index #30) and two Snap Rings (Index #23)	1	1235A, 1235, 1025
25A	1235A	SHAFT—wheel, 1 5/8", used on tiller serial No's. 31456 to 600008. No longer available, use Part #1878	1	1235, 1025
25B	1879	SHAFT—wheel, 1 8/8", for tiller serial No. 31455 & Below. Includes Hi-Pro Key (Index #30) and two Snap Rings (Index #23)	1	1025
25C	1025	SHAFT—wheel, 1 8/8", used on tiller serial No's. 31456 & Below. No longer available, use Part #1879	1
26	1232	GEAR—high speed, wheel drive, used on tiller serial No. 33548 & up....	1	1005
26A	1005	GEAR—high speed, wheel drive, used on tiller serial No. 33547 & below	1	see page 10

Continued on Page 6

INDEX NO.	PART NO.	DESCRIPTION	NO. REQ'D	REPLACES
WHEEL SHAFT ASSEMBLY (continued)				
27	1237	CLUTCH—wheel drive, speed change	1	1006
28	1112	PIN—clutch guide, 1/4" diameter	3
29	1223	GEAR—low speed, wheel drive, used on tiller serial No. 33548 and up	1	1004
29A	1004	GEAR—low speed, wheel drive, used on tiller serial No. 33547 & below	1	see page 10
30	9357	KEY—Hi Pro, 1/4" x 1 3/4", connects wheel shaft to clutch. Heavy-duty key for No's. 1878 & 1879 shafts (Index No's. 25 & 25B)	1	9305, 1103
30A	9305	KEY—Hi Pro, 1/4" x 1", connects wheel shaft to clutch. Use with No's. 1235A & 1025 shafts (Index No's. 25A & 25C)	1	1103
31	1094	SHOE—clutch shifting fork, for Tiller Serial No. 493013 & Below	2
32	1016	FORK—clutch shifting, wheel speed, for Tiller Serial No. 493013 & Below	1
33	1027A	ECCENTRIC SHAFT—clutch fork, includes two "O" Rings, Index #35, for Tiller Serial No. 493013 & Below	1	1027
34	1041	SHAFT—clutch fork, for Tiller Serial No. 493013 & Below	1
35	9603	"O" RING—eccentric shaft oil seal, for Tiller Serial No. 493013 & Below	2	1137
36	1029	LEVER—eccentric, wheel speed shift	1
PINION SHAFT ASSEMBLY				
13	9301	KEY—3/16" square x 1"	1	1071 & 1105
37	1060A	PLUG—pinion bearing, right & left, includes "O" Ring, Index #39	2	1060
38	9309	PIN—roll (spirol) 1/4" x 2", retains #1060A plug	2	1061
39	9604	"O" RING—pinion bearing plug, oil seal	2	1062
40	1132-1	SHIM—1-1/64" I.D. & 0.033" thick, bearing	as req'd	1132
40	1132-2	SHIM—SAME AS ABOVE 0.062" thick	as req'd	1132
40	1132-3	SHIM—SAME AS ABOVE, 0.010" thick	as req'd	1132
41	9404	BEARING—pinion shaft (ball bearing)	2	1059
42	1126	WASHER—pinion shaft (two or three)	as req'd
43	1233	GEAR—pinion, used on tiller No. 33548 and up, high wheel speed	1	1056
43A	1056	GEAR—pinion, used on tiller No. 33547 and below, high speed	1	see page 10
44	1221	WORM GEAR—bronze, wheel drive, used on tiller serial No. 33548 & up (for key see Index 55)	1	1057
44A	1057	WORM GEAR—bronze wheel drive, used on tiller serial No. 33547 & below (for key see Index 55)	1	see page 10
45	9502	RING—retaining (snap ring, external) Index 44 to 43	1
46	1222	STEM PINION—(gear & shaft) used on tiller serial No. 33548 & up	1	1055
46A	1055	STEM PINION—(gear & shaft) used on tiller serial No. 33547 & below	1	see page 10
55	9300	KEY—3/16" square x 5/8", high speed pinion gear	1	1088
TILLER SHAFT ASSEMBLY				
13	9301	KEY—3/16" square x 1"	2	1071 & 1105
19	9911	LOCKWASHER—Hi-collar, 1 1/4", use with socket head screws	5	1209
47	9616	SEAL—oil, tiller shaft, left and right sides	2	9602, 1092
48	1715	TAPERED BEARING & CUP—Cone roller bearing with cup (race), tiller shaft, left and right sides. Cones and cups are not available separately	2	1089, 9402, 9403
50	1064	WORM GEAR—bronze, tiller shaft, must be used with #1550 or #1268 drive shafts, or #1024 drive shaft & #1063 worm.....	1
51	1026A	SHAFT—tiller, includes #1104 key (Index #52)	1	1026
52	1104	KEY—tiller shaft, woodruff with ends ground	1
53	1129-1	GASKET—tiller housing cover, 0.010" thick	as req'd
"	1129-2	GASKET—SAME AS ABOVE, 0.030" thick	as req'd
54	1872	COVER—tiller housing. New style introduced week of March 30, 1981. Comes with 5 screws, Index No. 9780. For use with all Horse Models	1	1023
56	9718	SCREW—socket hd., 1/4"-20 x 3/4", use with old-style tiller housing cover and #9911 lockwasher	5	1208

INDEX NO.	PART NO.	DESCRIPTION	NO. REQ'D	REPLACES
TRANSMISSION COVER & NEUTRAL SPRING ASSEMBLY				
57	1123	GASKET—transmission cover	1
58	1003	COVER—transmission	1
59	1251	SPRING—neutral plunger (REMOVE WITH CARE), use for tiller No.'s 369446 & below	1	1036
59A	1496	SPRING—neutral plunger (REMOVE WITH CARE), use for tiller No.'s 369447 & up	1	1251
60	1035	PLUNGER—neutral (includes clip ring, #9504, index 72), (REMOVE WITH CARE)	1
61	9831	FLANGE NUT—hex., 3/8"-16, locknut	1	9802
62	9558	SCREW—hex. head, 3/8"-16 x 1 1/2", threaded full length	1	9712, 9713
63	9751	SCREW—hex head, 5/16"-18 x 1", grade 5, neutral plunger retainer, (REMOVE WITH CARE) see index No.'s 59 & 60	1
64	9801	NUT—hex. nut 5/16"-18	1
65	9727	PLUG—pipe, oil filler hole (used only on machines prior to Tiller Serial No. 38260), 3/8" square pipe plug, see Page 12, Index 7	1
66	9713	BOLT—hex. head 3/8"-16 x 1 1/2" transmission cover	4
67	9913	LOCKWASHER—3/8"	4	1212
TRANSMISSION HOUSING, PLUGS & ROLL PINS				
68	9727	PLUG—pipe, 3/8", clutch fork shaft. Used on Tiller Serial No.'s 222497 to 493013	1	9726
68A	9726	PLUG—pipe, 1/4", oil level and drain. Clutch fork shaft (for Tiller Serial No. 222496 & below)	3	1130
69	9307	PIN—roll (spiral), 3/16" x 1 1/4", eccentric lever, index #36	1
70	9122	PLUG—red plastic, thread protector	1	1217
71	TRANSMISSION CASE, HOUSING & TUBE ASSEMBLY—without covers, shafts or gears, etc. (Call factory for service help)	1
72	9504	CLIP RING—retains neutral plunger	1

Important Information About The Main Drive Shaft On Your Tiller

Your new tiller is equipped with either the single-piece welded drive shaft shown on Page 4 (Index 8) of this catalog, or with the assembled drive shaft shown at the top of Page 9 (Index No.'s 1-9). Both style drive shafts are equal in performance and dependability, the one your tiller has depends upon materials available when your machine was produced. You'll want to know which style you have if you disassemble the transmission for repair work. Otherwise, it doesn't make much difference. During disassembly, you can easily identify which style you have by comparing your drive shaft with the ones shown below.

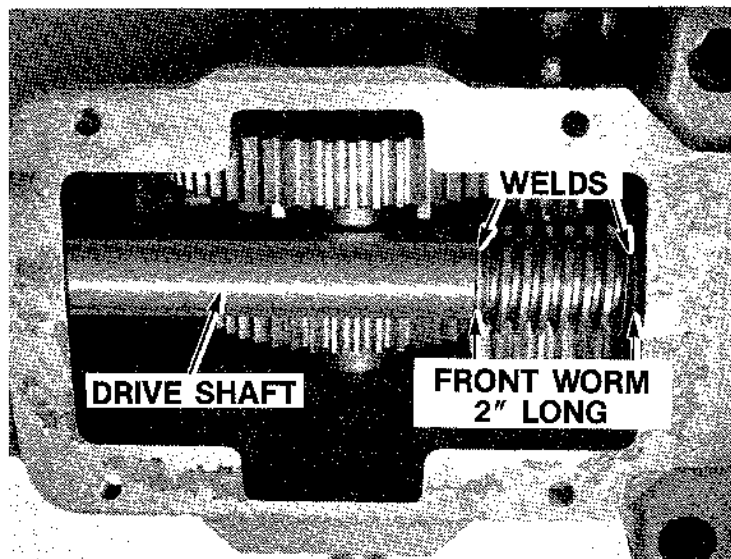

SINGLE PIECE WELDED DRIVE SHAFT

Shown at the left is a single piece welded drive shaft as it appears inside the transmission case (with the top cover removed). Welded drive shafts can be identified by the weld beads at both ends of the front worm, or by measuring the length (2-inches) of the worm. See Page 4, Index No. 8, for more information.

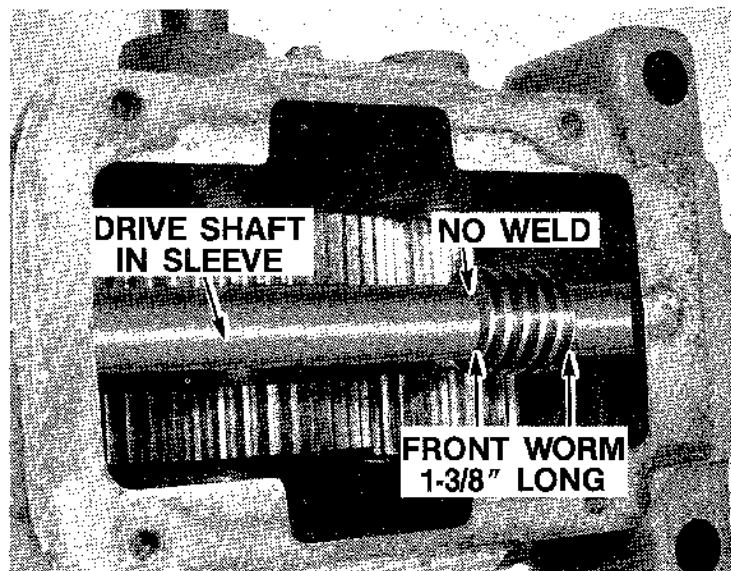

ASSEMBLED DRIVE SHAFT

If your drive shaft looks like the one at the left, then you have an assembled shaft (Part No. 1268). Note that there are no welds at the ends of the front worm, and that the worm measures just 1 $\frac{3}{8}$ -inches long. See Page 9, Index No.'s 1-9, for more information.

INDEX PART
NO. NO.

DESCRIPTION

NO.
REQ'D REPLACES

Assembled Drive Shafts

NOTE 1 —

The assembled style drive shaft shown below was first used with Tiller Serial No. 14159, and is still occasionally substituted for the #1902 welded drive shaft (see Page 8 to identify your style shaft). This shaft consists of individually assembled parts (listed below), compared to the welded shaft which incorporates everything into a single unit (except the front bearing cone and cup). Shims are used at the end of the shaft to adjust "play" out of the shaft.

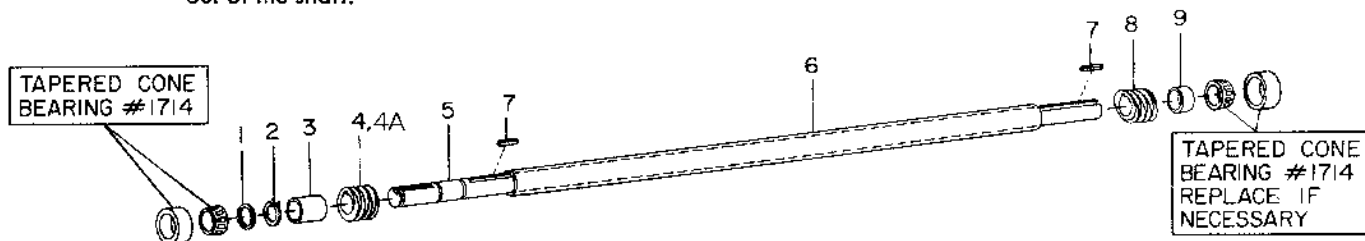

1	1138-1	SHIM—bearing front, 1/16" thickness	as req'd	
2	9500	RING—retaining (snap ring, external), drive shaft, front	1	1109
3	1065	SPACER—drive shaft, front	1	
4	1220	WORM—single lead, polished steel, drive shaft, front wheel drive	1	1058
4A	1058	WORM—double lead, polished steel, drive shaft, front wheel drive, used from earliest Horse Model tiller to Tiller Serial No. 33547	1
5	1024	SHAFT—main drive, 3/4"	1
6	1219	SLEEVE—spacer, separates steel worms on main drive shaft	1	1067
7	9301	KEY—3/16" square x 1"	2
8	1063	WORM—double lead, polished steel, rear of drive shaft	1
9	1066	SPACER—drive shaft, rear, between worm & cone bearing	1

NOTE 2 —

Tiller Serial Numbers 14158 and below and Tiller Serial Numbers 14518 though 14717 have the drive shaft style shown below. This drive shaft uses an adjustment nut and a special lockwasher on a threaded spacer sleeve to adjust the "play" out of the shaft.

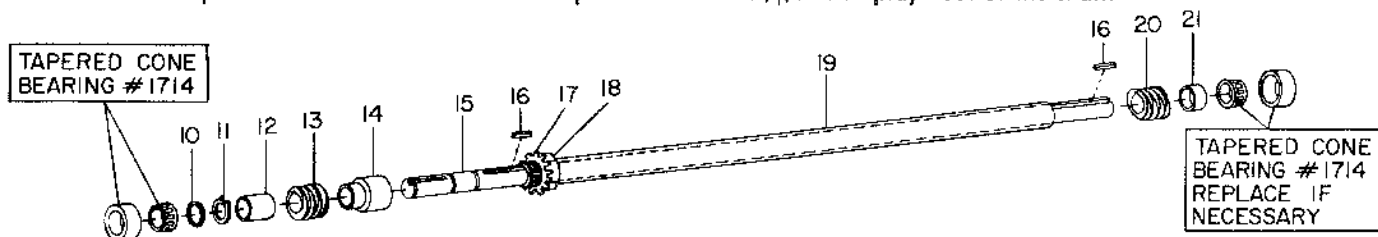

10	1138-1	SHIM—bearing front, 1/16" thickness	as req'd	
11	9500	RING—retaining (snap ring, external), drive shaft, front	1	1109
12	1065	SPACER—drive shaft, front	1
13	1058	WORM—double lead, polished steel, front of drive shaft	1
14	1070	BUSHING—thrust, spacer, drive shaft	1
15	1024	SHAFT—main drive, 3/4"	1
16	9301	KEY—3/16" square x 1"	2	1071 & 1105
17	1069	WASHER—fab locking, adjustment nut	1
18	1068	NUT—drive shaft adjustment	1
19	1067	SLEEVE—spacer, drive shaft, separates steel worms, front end threaded for adjustment	1
20	1063	WORM—double lead, polished steel, rear of drive shaft	1
21	1066	SPACER—drive shaft, rear, between worm & cone bearing	1

INDEX PART
 NO. NO.

DESCRIPTION

NO.
 REQ'D REPLACES

Wheel Gear Combinations & Wheel-to-Tine Ratios

Beginning with tiller serial No. 33548 and those that have followed, a new high & low gear ratio is used to govern wheel speeds so that the new tillers will do an even better job of tilling in low gear and will permit light tilling in high gear. Earlier models were generally restricted to cultivating between crop rows in high gear, with all tilling accomplished in low gear.

The new gear ratio means that in low gear the tines will rotate 13½ times faster than the wheels. In high gear, the tines rotate 5½ times faster than the wheels. The tines rotate at 146 RPM in either gear. The wheel/tine ratio is changed by differing wheel speeds.

With earlier gear ratio, tines rotated 10 times faster than the wheels in low gear.

All of these figures are based on an engine speed of 3,000 RPM.

Listed below are the pinion gears, worms, worm gears, and high, low wheel gears that go with each gear ratio. Please refer to the proper gear ratio for your tiller according to the serial numbers listed below.

For a better understanding of the positions and functions of the various gears and worms, please refer to page 11.

THIRTEEN & ONE-HALF TO ONE GEAR RATIO:

Tiller Serial Numbers 33548 & Up

PLEASE NOTE:

The 1200 series of worms and gears which provide the 13½ to 1 gear ratio can be used with either the welded drive shaft or the assembled drive shaft (without the adjustment tab washer). See Index 8, Page 4 and Index 5, Page 9.

4	1220	WORM—single lead, polished steel (see page 9)	1
44	1221	WORM GEAR—bronze, wheel drive (see page 4)	1
46	1222	STEM PINION—gear & shaft, low speed (see page 4)	1
29	1223	GEAR—low speed, wheel drive (see page 4)	1
26	1232	GEAR—high speed, wheel drive (see page 4)	1
43	1233	GEAR—pinion, high speed (see page 4)	1

TEN TO ONE GEAR RATIO

Tiller Serial Numbers 33547 & Below

(Use with #1024 drive shaft only — see Index 15, Page 9)

13	1058	WORM—two lead threads, polished steel (see page 9)	1
44A	1057	WORM GEAR—bronze, wheel drive (see page 4)	1
46A	1055	STEM PINION—gear & shaft, low speed (see page 4)	1
29A	1004	GEAR—low speed, wheel drive (see page 4)	1
26A	1005	GEAR—high speed, wheel drive (see page 4)	1
43A	1056	GEAR—pinion, high speed (see page 4)	1

Shafts and Gears

RELATIVE POSITIONS & FUNCTIONS

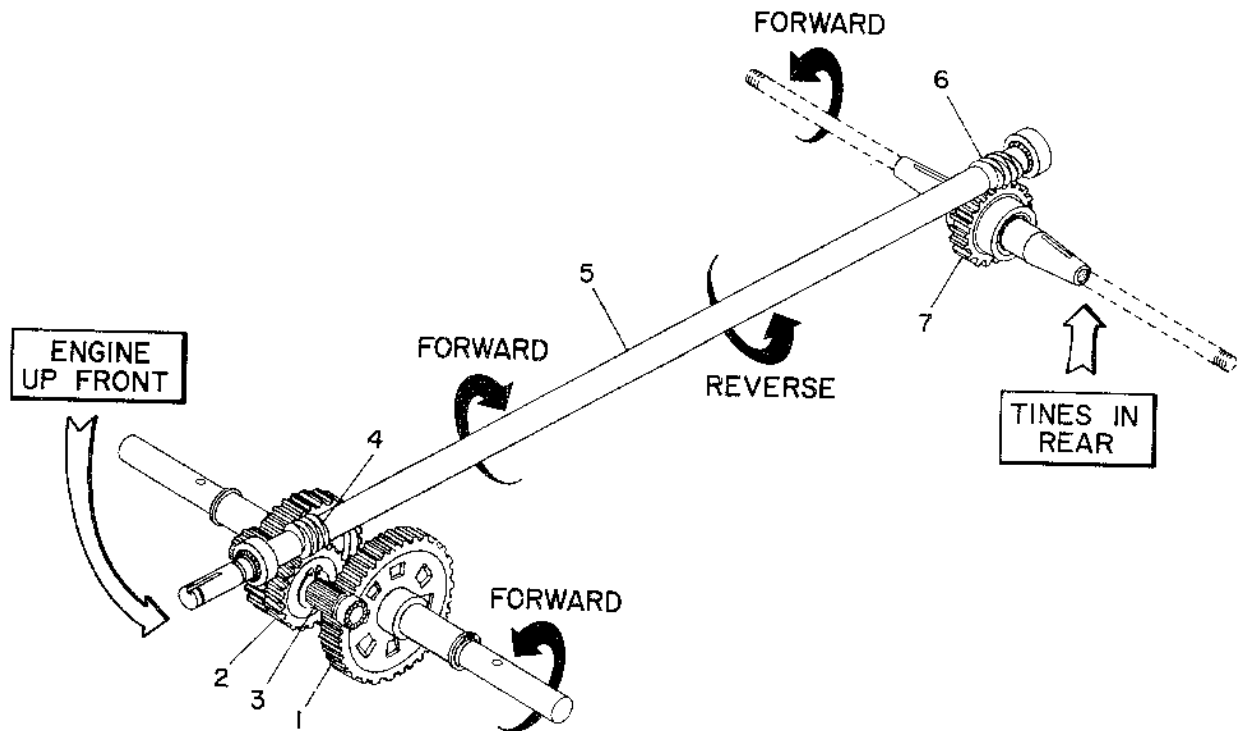

In your Troy-Bilt Roto Tiller-Power Composter, engine power is transmitted through the engine pulley by the drive belt(s), or by the reverse disc to the lower drive pulley. The belt(s) provides forward motion and the reverse disc supplies reverse motion.

When the lower pulley turns clockwise (as if you were standing in front of the engine), it turns the main drive shaft No. 5 in the same direction.

The drive shaft turns clockwise and the Bolo tines revolve in the forward direction whenever the Forward/Reverse Lever is pushed down into forward position. This alone does not turn the wheels, however. The wheel shift lever must be engaged in either Fast or Slow position for the wheels to move.

The wheel shaft assembly No. 1 includes a cast iron, larger, low speed gear in the foreground and an iron, smaller, high speed gear in the background. In between the two is a "dog" clutch which moves left and right to engage openings in the gears. Midway is the neutral or free-wheeling position. When the engine power turns the drive shaft No. 5 clockwise, the wheel gears turn in a bath of oil whether or not the clutch is engaged. How then does your Tiller turn the wheels? Let's look at the transmission of power from the engine.

As stated, the engine power is transmitted (in forward shift position) by the belt(s) which turns the

drive shaft clockwise. The drive shaft No. 5, turns steel worms (No's. 4 & 6) to drive both the wheels and the tines. The front worm turns a bronze worm gear No. 2 (which is keyed to the pinion shaft No. 3) and high and low speed pinion gears. The pinion gears drive the corresponding wheel drive gears constantly. The clutch between the wheel gears is keyed with a Hi-Pro key to the wheel shaft. When a wheel gear and the clutch are engaged, the wheel shaft turns, transmitting power to the wheels through the wheel pins.

The illustration shows that the front and rear steel worms (No's. 4 & 6) turn whenever the drive shaft rotates. The tiller worm No. 6 turns the bronze worm gear No. 7. Since the bronze worm gear is keyed to the tiller shaft, the gear and tiller shaft rotate together.

The direction of wheel and tine rotation is determined by the clockwise rotation of the main drive shaft No. 5 (forward motion) caused by the belt(s), or the counterclockwise rotation of the drive shaft caused by the reverse disc.

The tines will rotate whenever the main drive shaft rotates. Whether or not the wheels rotate depends upon the position of the speed shift lever. The wheels cannot obtain power unless the main drive shaft (and tines) are rotating.

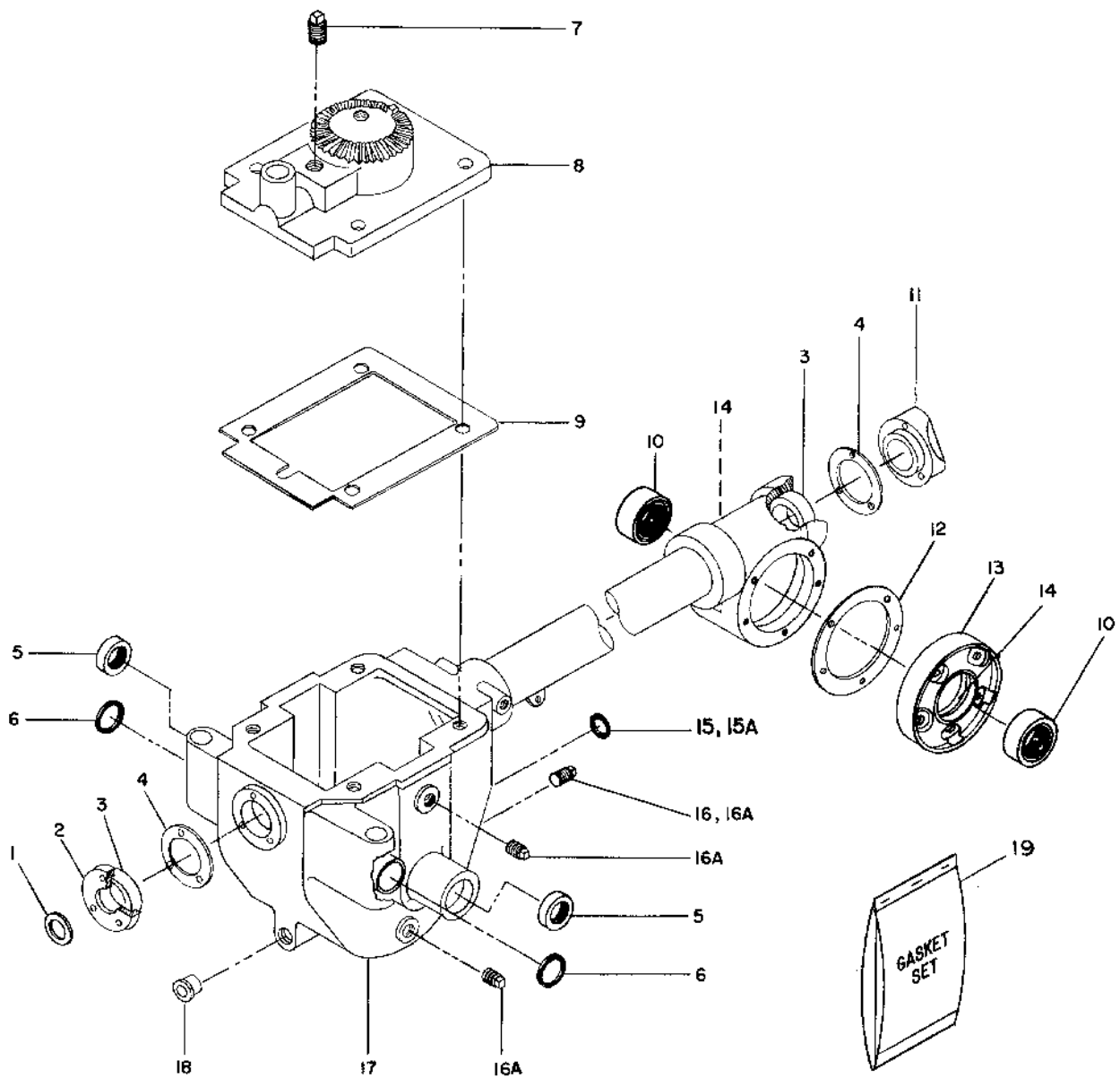

INDEX NO.	PART NO.	DESCRIPTION	NO. REQ'D	REPLACES
SEALS, COVERS, GASKETS & PIPE PLUGS				
1	9600	OIL SEAL—drive shaft	1	1090
2	1114	CAP—front bearing	1
3	1714	CUP—drive shaft bearing. Comes with cone roller bearing (not shown), see Page 4, Index No. 6	2	1108, 9401, 9400
4	1124-2	GASKET—bearing cap, front and rear	2	1124
5	9609	OIL SEAL—wheel shaft (axle), left and right sides	2	9601
6	9604	"O" Ring—fitted to Pinion Bearing retainer plug, right/left	2	1062
7	9727	PLUG—pipe, 3/8", fitted to oil filler hole on #1003 transmission cover used on tiller serial No.'s 38259 & below	1	1107
8	1003	COVER—transmission case	1
9	1123	GASKET—transmission cover	1
10	9616	OIL SEAL—tiller shaft	2	1092, 9602
11	1115	CAP—rear bearing	1
12	1129-1	GASKET—tiller housing cover, 0.010" thickness	as req'd
12	1129-2	GASKET—tiller housing cover, 0.030" thickness	as req'd
13	1872	COVER—tiller housing. New-style introduced week of March 30, 1981. Comes with 5 self-locking screws, Part No. 9780. Replaces earlier cover that used #9911 lockwashers and #9718 socket head screws. For use with all Horse Models	1
14	1715	CUP—tiller shaft bearing. Comes with cone roller bearing (not shown), see Page 4, Index No. 48. One cup pressed in #1023 cover, one installed inside tiller housing, right side	2	1089, 9402, 9403
15	9611	SEAL—oil, for single pin eccentric shaft. Used on Tiller Serial No.'s 493014 & Up. See Page 4, Index 18	1	9603
15A	9603	"O" RING—for eccentric shaft used on Tiller Serial No.'s 493013 & Below. See Page 4, Index No.'s 33 & 35	2	1137
16	9727	PLUG—pipe, 3/8", clutch fork shaft (see Page 4, Index 68). Used on Tiller Serial No.'s 222497 to 493013	1	9726
16A	9726	PLUG—pipe, 1/4", oil level, oil drain on all tillers. Clutch fork shaft for Tiller Serial No.'s 222496 & below (see Index 68A, Page 4)	3	1130
17	CASE—transmission housing & tube assy. (Contact service dept. directly)	1
18	9122	PLUG—red plastic thread protection, threaded hole for Dozer Blade Mount	1	1217
19	1121A	GASKET SET—includes one #1123, two #1124-2, two #1129-1 and one #1129-2	as req'd	1121

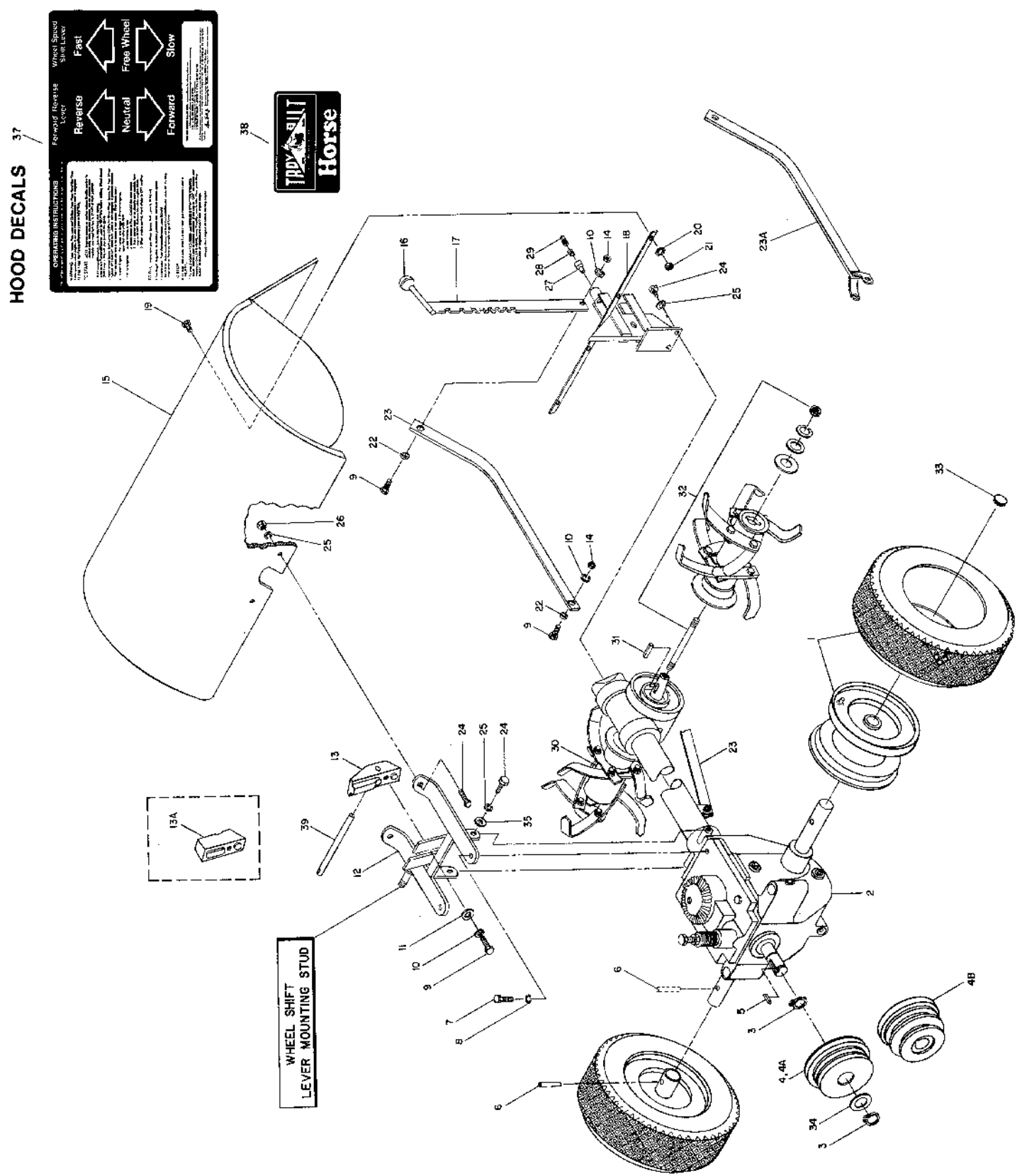

NOTE 1—Tillers numbered 24574 & below used drag bar #1116 for the depth regulating assembly with spacer bushings #1113, two 5/16" flat washers #9902, two #9912 lock washers, and two #9705 hex. head screws. To use old style #1116 depth reg. drag bar on new transmission, break off the welded tab on transmission tube — where #9710 bolt attaches #4763, drag bar.

NOTE 2—Part #9142 wheel assembly may be used with Tiller Serial No's. 31041 & Up provided wheel shaft (Part #1025) has two holes on each end of shaft. For Tiller Serial No's. 31455 & Below, see Page 17, Index 3. For Bar Tread Tires, see Page 16, Index No's. 1 or 13.

INDEX NO.	PART NO.	DESCRIPTION	NO. REQ'D	REPLACES
TILLER, TINES, HOOD, WHEELS, DEPTH REGULATOR				
1	9142	WHEEL ASSEMBLY—standard tread, 4:00/4:80 x 8 tubeless tire and valve stem, mounted on single-piece steel wheel. Used on tillers with Part #1235 or 1878 wheel shaft for Tiller Serial #31456 & Up. (see Note 2, Page 14)	2
2	CASE—transmission housing & tube assy. (Contact service dept.)	1
3	9500	RING—retaining (snap ring external, transmission drive pulley)	2	1109
4	1008-1	PULLEY—matched belts, transmission drive, cast iron, Tiller Serial #4333 & Up. Prior to Serial #5984, pulleys were aluminum	1	1008A
4A	1008	PULLEY—single belt, variable speed, tiller serial No. 4332 & below, 4½ H.P. maximum	1
4B	1484	PULLEY—transmission drive, cast iron, uses single belt, and rubber rimmed reverse disc	1	1008-1
5	9301	KEY—3/16" square x 1" long, pulley to drive shaft	1	1101, 9302
6	9322	PIN—roll (spiral), 5/16" x 1½" long wheel hub to shaft	2	1097
7	9713	BOLT—¾"-16 x 1½", see page 4, Index 66	4
8	9913	LOCKWASHER—¾", see page 4, Index 67	4
9	9710	BOLT—hex. head, ¾"-16 x 1", belt adj. block, depth regulator	3
10	9913	LOCKWASHER—¾"	3
11	9903	WASHER—flat, ¾", regular standard	1
12	1077	BRACKET—hood, front, belt adj. block, & stud for wheel shift lever	1
13	1920	BLOCK—belt adjustment, 3¾" long, for four-speed tillers, Serial #314151 & Up. Includes Index #'s 9, 10, 11 & 39. Use with Part #1921 engine yoke or #1487 engine yoke (with tab removed)—see Page 21, Index 7	1	1133-1A
13A	1133-1A	BLOCK—belt adjustment, 3¾" long, for two-speed tillers, Serial #314150 & Below. Has cast-in Neutral position. Replaces ¾" steel bar (completely flat) used previously. Includes Index #'s 9, 10 & 11.	1	1133
14	9802	NUT—hex, ¾"-16	2
15	1519	HOOD—tine cover with hinged flap, includes hood decals	1	1082
16	9119	KNOB—with spring retainer. Also see Index #20A, Page 23	1
17	1117A	BAR—depth adjustment, includes Knob, Index #16	1	1117
18	1076	BRACKET—hood, rear (includes roll pin, Part #9308)	1
19	9723	SCREW—round head, ¼"-20 x ¾"	4
20	9910	LOCKWASHER—¼"	4
21	9800	NUT—hex., ¼"-20	4
22	1113-1	BUSHING—spacer, drag bar, also see Page 24, Index #53	2
23	4763	DRAG BAR—depth regulator, tiller serial No. 24575 & up (see note 1)	1	1116
23A	1116	DRAG BAR—depth regulator, tiller serial No. 24574 & below. See page 41, Index 5, also Note 1, page 14.	1
24	9703	BOLT—hex. head 5/16"-18 x ¾"	6
25	9912	LOCKWASHER—5/16"	6
26	9801	NUT—hex, 5/16"-18	2
27	1119	PLUNGER—depth regulator locking	1
28	1120	SPRING—depth reg. plunger	1
29	9726	PLUG—pipe ¼", see page 4, Index 68A	1
30	BOLO TINE ASSEMBLY, RIGHT (see page 18)
31	9301	KEY—3/16" square x 1", tine shaft	2
32	See Tine Assemblies, Pages 18 & 19
33	9145	HUB CAP—wheel	2
34	1138-1	SHIM—transmission pulley, 1/16" thickness	as req'd
35	9902	WASHER—flat, 5/16" S.A.E., O.D. 11/16"	2
36	9712	BOLT—hex. head, ¾"-16 x 1¼"	1	9710
37	1239	DECAL—hood, operating instructions for 6 & 8HP engines. 7HP Kohler engine owners specify Part #2156 decal	1
38	1238	DECAL—Troy-Bilt, 3" x 7½"	1
39	2100	ROD—belt adjustment, 7" long, with measuring gauge. For use with Part #1920 (Index #13) adjustment block	1

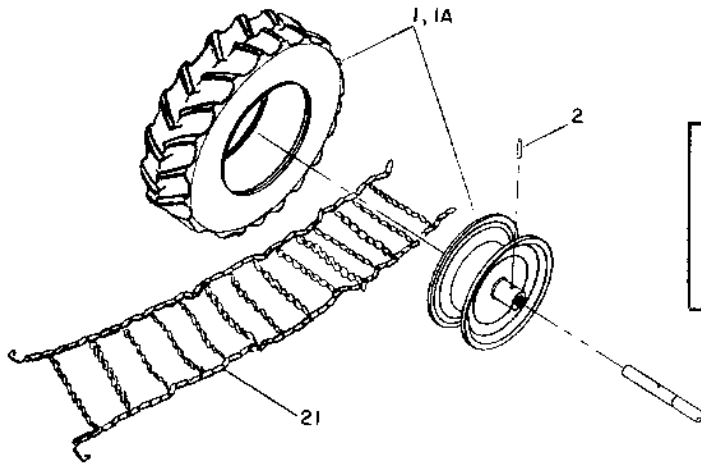

PLEASE NOTE: Part #'s 9143 & 9144 (tubeless Bar Treads) must be a matched pair. When ordering a replacement wheel & tire, please specify the manufacturer's name on the tire you're keeping (such as Goodyear, or McCreary, etc.). Thank you.

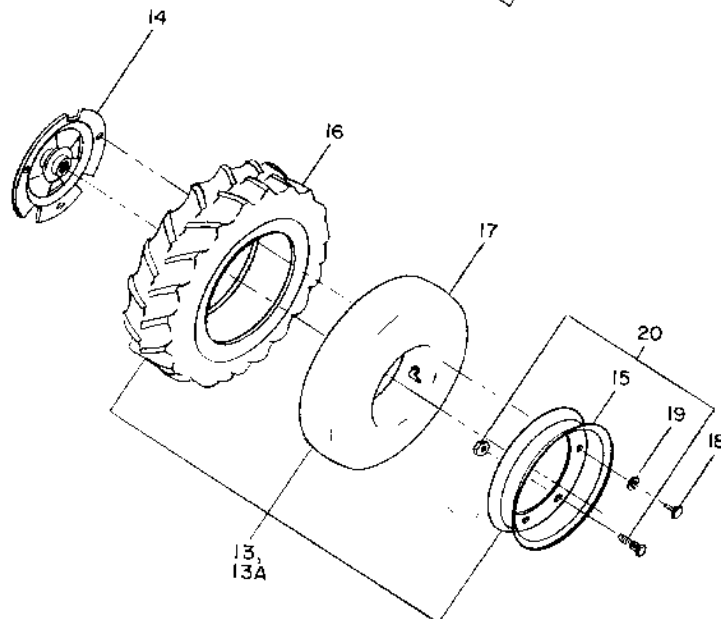
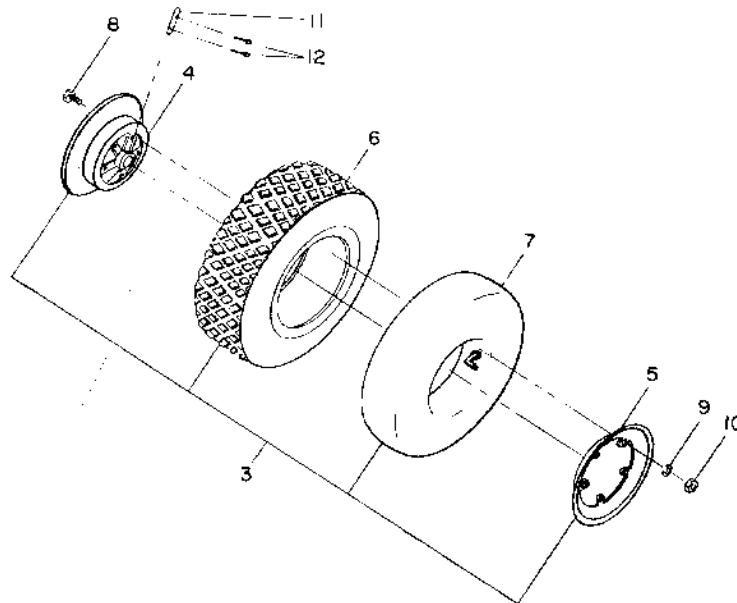

INDEX NO.	PART NO.	DESCRIPTION	NO. REQ'D	REPLACES
TWO-PIECE CAST IRON WHEELS, TIRE OPTIONS, CHAINS				
1	9144*	WHEEL ASSEMBLY—Bar Tread Tire, RIGHT SIDE, 4:80 x 8 tubeless tire mounted on single piece wheel, use with #1878 or #1235A wheel shaft, tiller No.'s 31456 & Up (optional)	1
1A	9143*	WHEEL ASSEMBLY—Bar Tread Tire, LEFT SIDE, (same as #9144, except left) use with #1235A or #1878 wheel shaft	1
2	9322	PIN—roll, (spiral), 5/16" x 1½"	2
3	9148	WHEEL ASSEMBLY—4:00 x 7 wheel, tire & tube, complete, cast iron, two piece, use with #1879 or #1025 wheel shaft (order wheel pins & cotter pins separately). Use for tiller No.'s 31040 & below, left & right are interchangeable	2
4	1018	WHEEL & HUB—7", cast iron, goes with #1017 & standard tread tire, requires 5 bolts, washers & nuts. Use with #1879 or #1025 wheel shaft, tiller No.'s 31040 & below	2
5	1017	RIM—wheel, 7", use with #1018 wheel & hub	2
6	9109	TIRE—standard tread, 4:00 x 7, tube type	2
7	9110	TUBE—4:00 x 7	2
8	9712	BOLT—hex. head ¾"—16 x 1¼", 5 per wheel	10
9	9913	LOCKWASHER—¾", 5 per wheel	10
10	9802	NUT—hex, ¾"—16, 5 per wheel	10
11	1097	PIN—wheel drive	2
12	9317	COTTER PIN—retains wheel pin, 3/32" x 1", 2 per wheel	4
13	9149*	WHEEL ASSEMBLY—4:00 x 8 Bar Tread wheel & tire, tube type, assembled, LEFT SIDE with hub, includes Index No.'s 14, 15 (pair), 16, 17 & 20, and three bolts & washers. Use with #1879 or #1025 wheel shaft, tiller No.'s 31040 & below	1
13A	9150*	WHEEL ASSEMBLY—4:00 x 8 Bar Tread, same as above, except RIGHT SIDE	1
14	1163	HUB—wheel, 8", cast iron, use with tube type Bar Tread Tire, included with Index 13 & 13A.	2
15	9113	RIM—wheel, 4:00 x 8, two piece unit, includes 3 assembly studs (see Index 20) & 3 mounting bolts & washers	2
16	9111	TIRE—Bar Tread 4:00 x 8, tube type. For tillers prior to serial No. 6186 using 5 x 8 Bar Treads, substitute 4 x 8 Bar Treads, or obtain replacement 5 x 8 tire locally	2
17	9112	TUBE—4:00 x 8, for Bar Tread Tire	2
18	9709	BOLT—hex head, ¾"—16 x ¾", 3 per wheel, for mounting	6
19	9913	LOCKWASHER—¾", 3 per wheel	6
20	STUD & NUT—fastens 2-piece rim together to make #9113 rim, 3 per wheel, not sold separately	6
21	9146	CHAINS—tire, 4:80/4:00 x 8, fits #9143 & 9144, or #9142 standard tire, set. Tiller serial No.'s 26000 up to 31455 can use chains with tube type bar tread tires #9111	1

***PLEASE NOTE—**

Bar Tread Tires are mounted on Troy-Bilt Horse so that the arrow on the side of the tire points in the direction of FORWARD rotation of the wheel. With tires mounted in this manner, the closed end of the "V" in the tire tread on top of the tire will face forward.

BOLO TINES ASSEMBLIES
 (Viewed From Front Of Tiller)

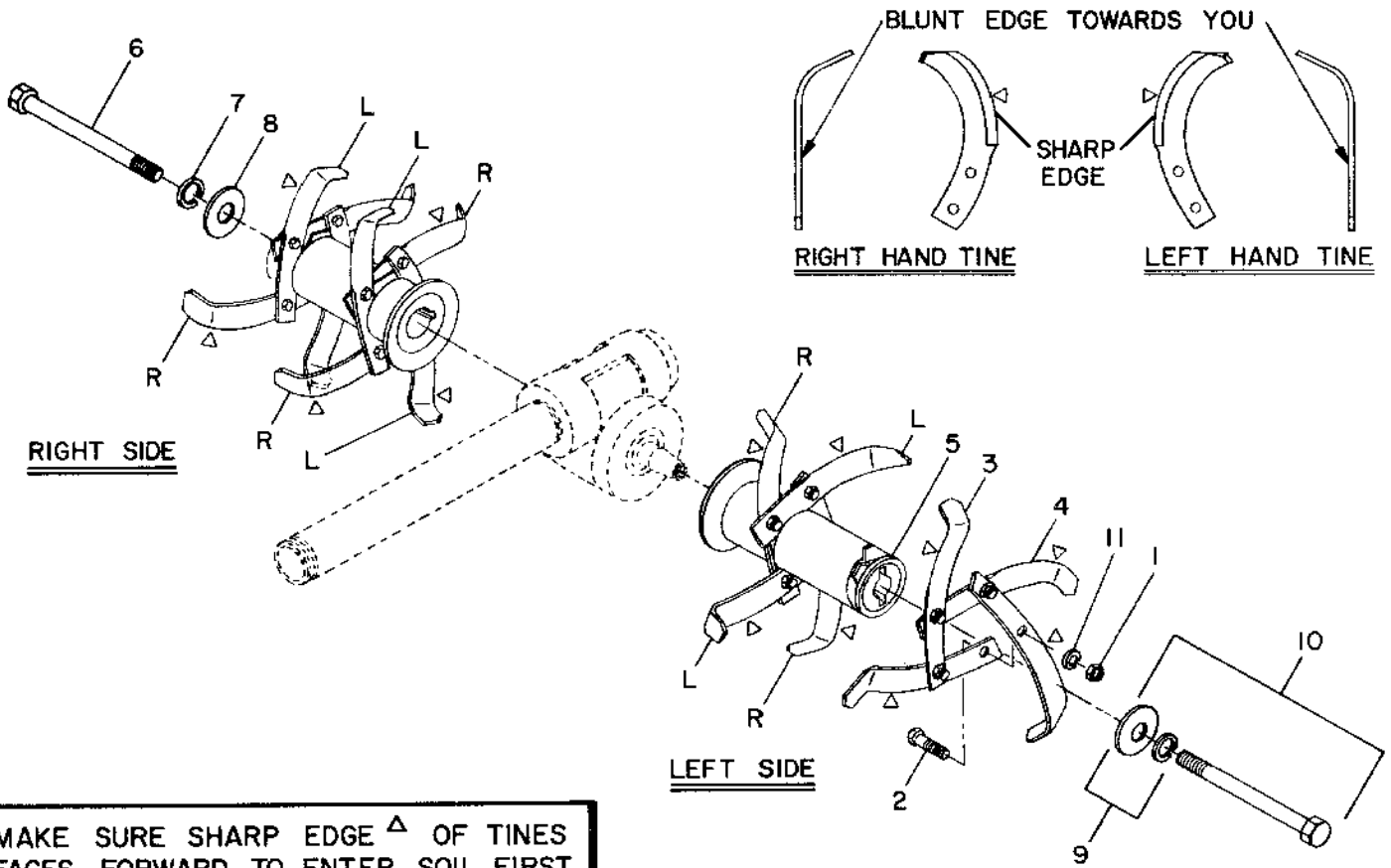

**MAKE SURE SHARP EDGE Δ OF TINES
 FACES FORWARD TO ENTER SOIL FIRST**

OLD-STYLE TINE HOLDER MOUNTING ARRANGEMENT

Beginning with Tiller Serial No. 308889, all tillers have been equipped with the new-style Bolo Tine holder mounting bolt and washer set shown at Index No. 10, above. This mounting arrangement makes it much easier to remove and replace the holders, if necessary.

As a result, we no longer stock the old-style, Part #1206 mounting stud (threaded on both ends), that is shown at Index No. 11, below. If you ever need to replace a #1206 stud, or if you simply want to update your tiller, you should order the Part #1735 bolt and washer set shown at Index No. 10, above (order two #1735's if you're replacing both studs).

We do, however, still stock the washers and nut that are used with the #1206 stud. Those items are shown below at Index No's. 12, 13, 14 & 15.

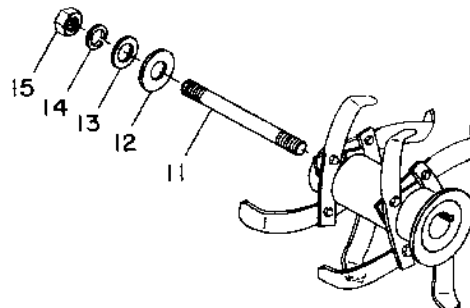

INDEX NO.	PART NO.	DESCRIPTION	NO. REQ'D	REPLACES
BOLO TINE ASSEMBLIES				
1	9802	NUT—hex., 3/8"-16, tine mounting	16	9807
2	9711	BOLT—hex. hd., 3/8"-16 x 1", tine mounting	16
3	1270-2A	BOLO TINE—single, RIGHT HAND tine used on left and right side bolo assemblies. Tine is stamped "ER" or "AR". Includes replacement hardware—two #9711 bolt, two #9913 lockwasher, & two #9802 hex nut. NOTE: These tines won't fit chopper tine holders	8	1142-2, 1270-R
4	1270-1A	BOLO TINE—single, LEFT HAND tine used on left and right side bolo assemblies. Tine is stamped "EL" or "AL". Includes same replacement hardware described for right hand tine above	8	1142-1, 1270-L
5	1205	HOLDER—Bolo Tines, for either side of tiller, each holder uses four left and four right hand tines	2
6	1463	BOLT—1/2"-20 x 5 3/4", threaded on one end, mounts bolo holder on tine shaft. For all Horse Model tillers, use with Part No's. 9914 & 1461. Replaces #1206 mounting stud (Index #11)	2	9805, 1206
7	9914	LOCKWASHER—1/2"	2
8	1461	WASHER—flat, 17/32", outer dia. 1 3/4"	2	9905, 9908
9	1207A	WASHER SET—for Part No. 1463 bolt. Includes two #9914 lockwashers (Index #7) and two #1461 washers (Index #8)	1 Set
10	1735	BOLT & WASHER SET—includes one #1463 mounting bolt (Index #6), one #9914 lockwasher (Index #7) and one #1461 washer (Index #8)	2 Sets
11	9913	LOCKWASHER—3/8", tine mounting	16
....	1246	BOLO TINE ASSEMBLIES—16 tines completely assembled on holders and ready to install on tiller. Includes two #1205 holders; 8 left hand and 8 right hand tines; hardware for tine mounting (16 bolts, lockwashers, nuts); hardware for holder mounting (2 each bolts, lockwashers, plain washers) and two #9301 tine shaft keys (see Page 14, Index #31)	1
....	1245K	SET OF 16 BOLO TINES WITH REPLACEMENT HARDWARE—unassembled. Includes 8 left hand and 8 right hand tines; hardware for tine mounting (16 each #9711 bolts, #9913 lockwashers, #9802 hex nuts). Does not include tine holders, holder mounting bolts, or tine shaft keys	1

OLD-STYLE TINE HOLDER MOUNTING ARRANGEMENT

11	1206	STUD—1/2"-20 x 6", threads on both ends. NO LONGER AVAILABLE. Replace with Part #1735 bolt and washer set, Index #10	2
12	9908	WASHER—flat, 5/8" standard size, outer diameter 1 3/4"	2
13	9905	WASHER—flat, 1/2" O.D. 1 3/8"	2
14	9914	LOCKWASHER—1/2"	2
15	9805	NUT—hex 1/2"-20, tine holder & stud to tine shaft	2

PLEASE NOTE—Left and right sides of tiller are determined by standing in the operator position and facing the direction of forward travel.

**SPECIAL PARTS FOR
FOUR SPEED HORSE MODEL**

**SEE PAGE 22 FOR ALL PARTS
OTHER THAN THE NINE PARTS
IDENTIFIED HERE**

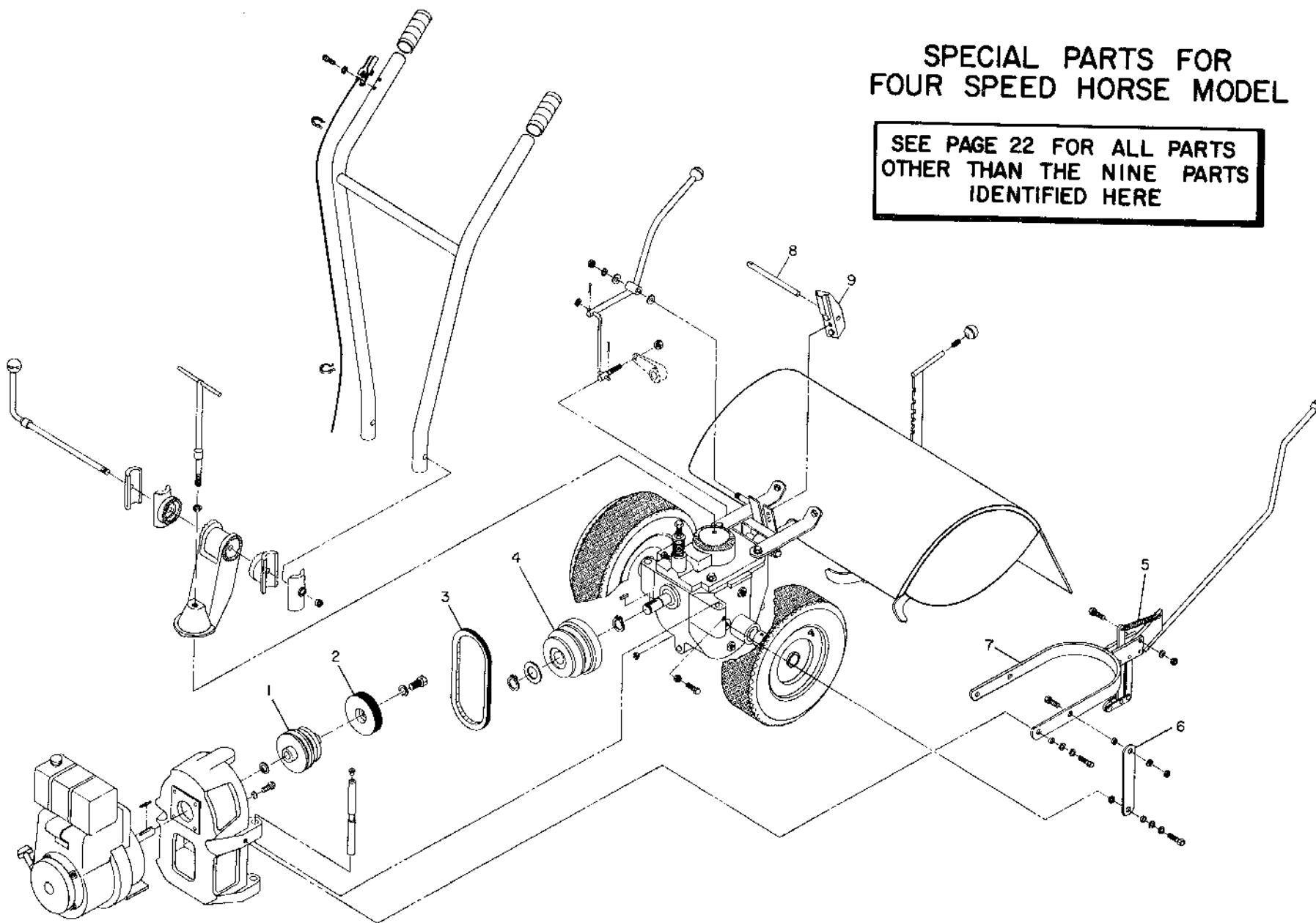

INDEX NO.	PART NO.	DESCRIPTION	NO. REQ'D	REPLACES
SPECIAL PARTS FOR FOUR-SPEED HORSE MODEL (Tiller Serial No. 314151 and Up)				
1	1483	PULLEY—engine PTO/driven, uses single belt, tiller serial No. 314151 & Up	1	1007-1
2	1919	REVERSE DISC—rubber rimmed, use only with Part #1484 transmission drive pulley (with flat surface for disc). For four-speed tiller only. Includes new-style Part #1920 adjustment block, see Index #9. Use only with #1920 block. If disc mounting bolt or lockwasher is needed, see Index #'s 16, 17 or 17A on Page 23.	1	1485, 1072
3	9245	BELT—single "V" belt, made specially for your tiller (no substitute recommended due to extra strength required)	1	1128 pair
4	1484	PULLEY—transmission drive, cast iron, uses single belt and rubber rimmed reverse disc, tiller serial No. 314151 & Up	1	1008-1
5	1492	SPRING—clutch pawl, for four-speed tiller only, tiller serial No. 314151 & Up	1	1122
6	1488	LINK—yoke pivot (clutch control), 6 ⁷ / ₈ ", use on four-speed tiller only....	1	1098
7	1921	CLUTCH CONTROL YOKE—for four-speed tiller only. Includes new-style Part #1920 adjustment block (Index #9). NOTE: Earlier-style Part #1487 yoke (with shifting tab) can be used with Part #1920 adjustment block, but tab must be removed—see removal instructions (Literature code SER-106)	1	1487
8	2100	ROD—belt adjustment, 7" long, with measuring gauge. For use with Part #1920 (Index #9) adjustment block	1
9	1920	BLOCK—belt adjustment, 3 ⁷ / ₈ " long, for four-speed tillers. Includes mounting hardware (see Index #'s 9, 10 & 11 on Page 15) and adjustment rod (Index #8 above). Use with Part #1921 yoke or #1487 yoke (with tab removed)	1	1133-1A

COMMON PARTS FOR
TWO SPEED & FOUR SPEED
HORSE MODEL

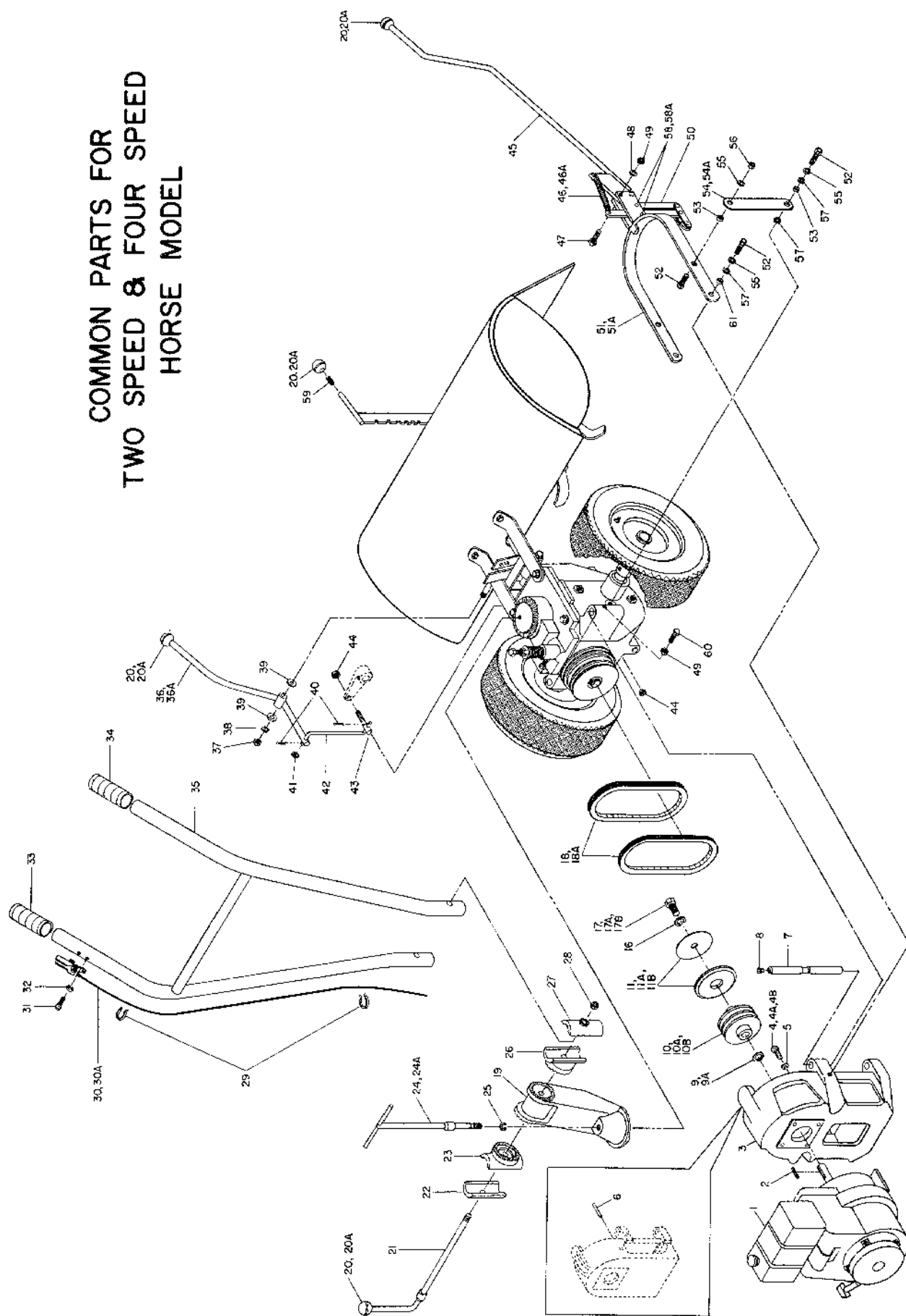

INDEX NO.	PART NO.	DESCRIPTION	NO. REQ'D	REPLACES
ENGINE & MOUNT, PULLEY, BELTS, HANDLEBARS & SHIFT LEVERS				
1	ENGINE—see Page 26 for engine listing	1
2	9303	KEY—3/16" square x 2½" engine pulley	1
3	1698	MOUNT—engine to tiller, with cast-in belt guides instead of roll pins	1	1002
4	9707	BOLT—5/16"-24 x 1", engine mtg. for Tecumseh & Briggs and Stratton engines	4
4A	9704	BOLT—hex. head, 5/16"-18 x 1", Clinton engine (mounting)	4
4B	9732	BOLT—5/16"-24 x 7/8", engine mounting to 7 H.P. Kohler mounting plate for tiller serial numbers 252356 & below	4
5	9912	LOCKWASHER—5/16"	4
6	9310	PIN—roll (spiral) ¼" x 2½" belt guide pins, used as belt guides with earlier style motor mount (also see Index 20, Page 41	2	1099
7	1034	BAR—engine mounting	2
8	9147	PLUG—thread protection, red plastic	2	9121, 1216
9	1138-1	SHIM—engine pulley, 1/16" thick, Tecumseh (2-5), Kohler (2, 5-7), Clinton (1)	as req'd
"	1138-2	SHIM—engine pulley, 1/32" thick, Tecumseh (1), Kohler (1), Briggs and Stratton (3), Clinton (2)	as req'd
9A	1213	SHIM—engine pulley, Clinton Engine, hardened, 1/16" thick, (1) closest to engine	as req'd
10	1483	PULLEY—engine PTO driven, uses single belt, for four-speed tillers, Tiller Serial #314151 & Up, see Index 4, Page 21	1	1007-1
10A	1007-1	PULLEY—engine PTO driven, uses pair of belts, tiller serial No.'s 2731 to 314150; between tiller serial No.'s 2731 and 5983 pulleys were aluminum and from No.'s 5984 & Up pulleys are cast iron	1	1007A
10B	1007	PULLEY—engine PTO driven, uses single belt tiller serial No. 2730 & below, 4½ H.P. engine maximum	1
11	1919	DISC—reverse, rubber rimmed, for four-speed tillers, see Index 2, Page 21. Includes Part #1920 adjustment block	1	1485
11A	1072A	DISC—reverse, hard fiber, with #1287 mtg. plate, for two-speed tillers, Serial No's. 163830 to 314150	1
11B	1072K	DISC—reverse, hard fiber, with #1287 mtg. plate & #1291 washer, for two-speed tillers, Serial No's. 163829 & below	1
16	9913	LOCKWASHER—¾"	1
17	9738	BOLT—hex hd., ¾"-24 x 1¾", engine pulley mtg., Tecumseh engine	1	1075, 9715
17A	9715	BOLT—hex hd., ¾"-24 x 1½", engine pulley mtg., Kohler & Briggs and Stratton engines	1
17B	9708	BOLT—hex head, 5/16"-24 x 1½", eng. pulley mounting, Clinton engine	1
18	9245	BELT—single "V" for four-speed tillers, see Index 3, Page 21	1
18A	1128	BELTS—"V", pair, tiller serial No.'s 2731 to 314150, two speed tillers. Earlier tillers used a single #1128 belt & #1007 pulley	1 pair
19	1019	BASE—handlebar, left-to-right adjustment	1	1261
20	9119	KNOB—wheel speed lever, forward/reverse lever, depth regulator, handlebar height adjustment, includes retaining ring, part #9120. Used on tiller serial No. 19331 & up	4	9136, 1118
20A	9136	KNOB—SAME AS ABOVE except threaded, ½"-13 thread, used on tiller serial No. 19330 & below	4	1118
21	1881	STUD—handlebar height adjustment, includes #9119 knob and #9803 nut	1
22	1021-2	CLAMP—handlebar adjustment, right	1
23	1020-2	RATCHET—handlebar adjustment, right	1
24	1043	CLAMP—"T" bar, handlebar mounting, 10½"	1
24A	1167	CLAMP—"T" bar, handlebar mounting, electric start, 14¼"	1
25	9915	LOCKWASHER—¾"	1
26	1020-1	RATCHET—handlebar adjustment, left	1
27	1021-1	CLAMP—handlebar adjustment, left	1
28	9803	NUT—hex., ½"-13	1	9805

COMMON PARTS FOR
TWO SPEED & FOUR SPEED
HORSE MODEL

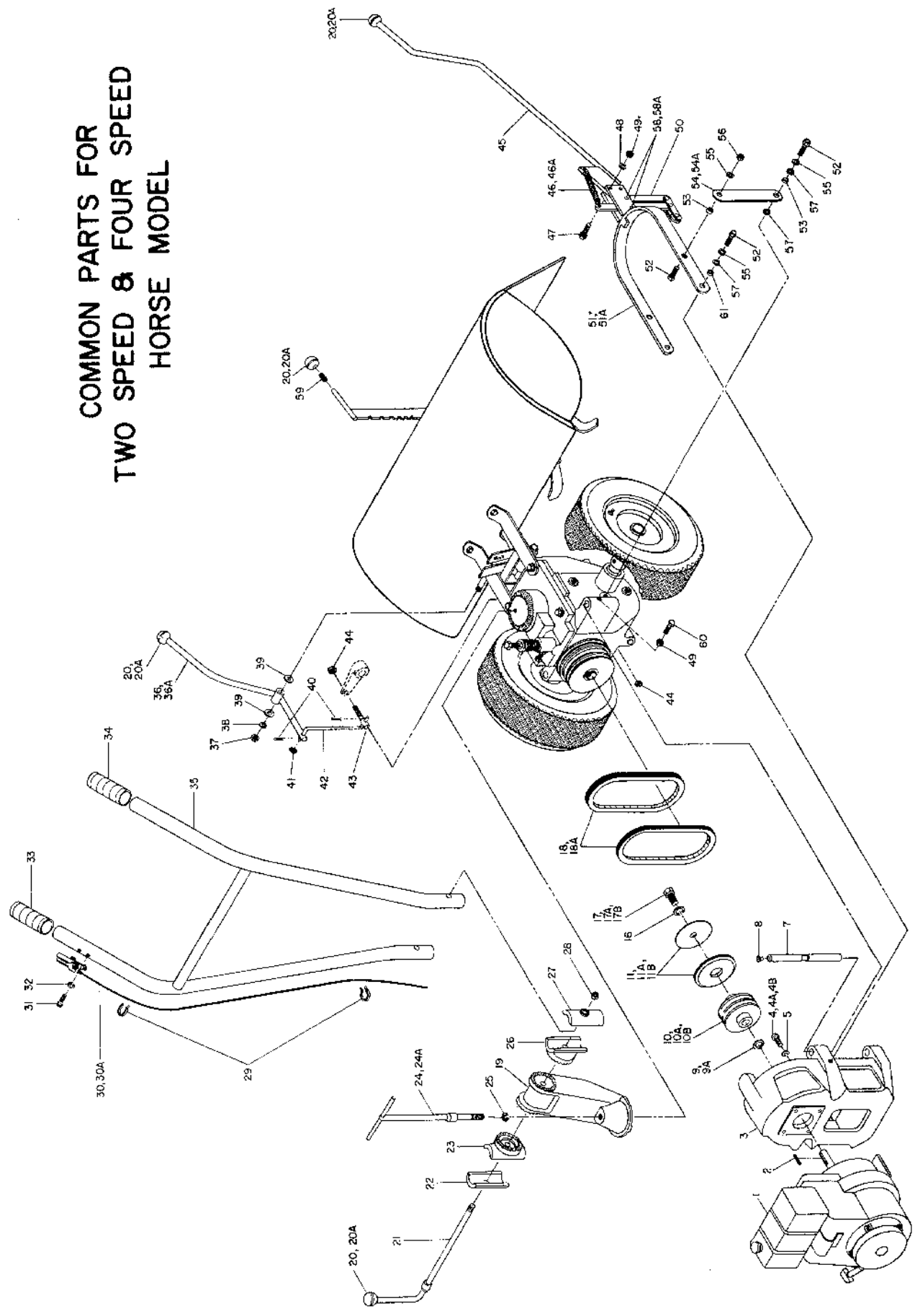

INDEX NO.	PART NO.	DESCRIPTION	NO. REQ'D	REPLACES
ENGINE & MOUNT, PULLEY, BELTS, HANDLEBARS & SHIFT LEVERS (continued)				
29	9116	CLIP—throttle cable retaining	1	1218
30	9240	CABLE—throttle, complete. For 6 HP Tecumseh (manual choke only), 7 HP Kohler, 4½ HP Clinton and 8 HP Briggs & Stratton engines. Also order #9733 screws & #9909 lockwashers, if needed.	1	1195, 9115
30A	9115	CABLE—throttle, complete. Use with 6 HP Tecumseh (automatic choke only) engines. Also order #9733 screws & #9909 lockwashers, if required.	1	1195
31	9733	SCREW—pan head, self-tapping	2
32	9909	LOCKWASHER—#10	2
33	9118	GRIP—rubber, handlebar, see Index 34 for electric start grip	2	1095
34	9141	GRIP—rubber, handlebar left side (for push-button electric start only). Use one instead of #9118. Includes starter button spacer #1180	1	9118
35	1046A	HANDLEBARS—includes two grips, specify standard or electric	1	1046
36	1843	LEVER—wheel shift, for single pin eccentric transmissions, Tiller Serial #493014 & Up. Includes #9119 knob and #9120 retaining ring.	1	1230A
36A	1230A	LEVER—wheel shift, for fork shoe transmissions, Tiller Serial #19741 to 493013. Includes #9119 knob and #9120 retaining ring. See Note 1 below	1	1030, 1230
37	9806	LOCKNUT—hex., ½"—20, self-locking	1	9804
38	9914	LOCKWASHER—½"	1
39	9907	WASHER—plain, ½" S.A.E. (inside washer optional)	2
40	9317	PIN—cotter, 3/32" x 1"	2
41	9902	WASHER—plain, 5/16" S.A.E., O.D. 11/16"	1
42	1231	ROD—connecting rod, speed shift lever	1
43	1033	SWIVEL—connecting rod	1
44	9808	LOCKNUT—hex. head, 5/16"-18	1
45	1134A	LEVER—forward/neutral/reverse, includes #9119 knob, Index #20	1	1134
46	1492	SPRING—clutch pawl, for four-speed tillers only, see Index 5, page 20	1
46A	1122	SPRING—clutch pawl for two-speed tiller	1
47	9705	SCREW—hex. head, 5/16"-18 x 1¼", lever to yoke	2	1211
48	9912	LOCKWASHER—5/16"	2
49	9801	NUT—hex. head, 5/16"-18	4
50	1042	ROLLER ASSEMBLY—clutch, Forward/Reverse	1
....	1051A	REPAIR KIT—roller assembly, includes #1051 roller, #9346 clevis pin and #9317 cotter pin	1
51	1921	YOKE—clutch control, no shifting tab on yoke, for four-speed tillers only, see Index 7, Page 21	1	1487
51A	1037	YOKE—clutch control, for two-speed tillers, Serial #314150 & Below.	1
52	9710	BOLT—hex. head, ¾"-16 x 1", yoke linkage	6
53	1113-1	BUSHING—spacer, 9/16" long, yoke linkage	4
54	1488	LINK—yoke pivot (clutch control), 6¾" long, four-speed only, see Index 6, Page 20	2
54A	1098	LINK—yoke pivot (clutch control), 6¾" long, two-speed tillers only	2
55	9913	LOCKWASHER—¾"	6
56	9802	NUT—hex., ¾"-16	2
57	9904	WASHER—plain, ¾" S.A.E., O.D. 13/16"	6
58	9323	ROLL PIN (spiral), 5/16" x 1"	2
58A	1136	RIVET—5/16" x 1¼", #36 drilled hole, clutch roller assembly prior to Tiller Serial No. 31208 rivets were used instead of roll pins	2
59	9120	RING—retaining (tolerance ring)	4
60	9704	BOLT—hex. head, 5/16"-18 x 1"	2
61	2146	BUSHING—spacer, 11/16" long, yoke to engine mount	2	1113-1

NOTE 1—For tiller serial No's. 19740 & below order #1230 wheel speed shift lever. It will include #9317 (2), #9902, #9808 & #1231 at cost of current price of #1230 lever. Please indicate that it is a replacement for part #1030 and it is for a tiller serial number below NO. 19741.

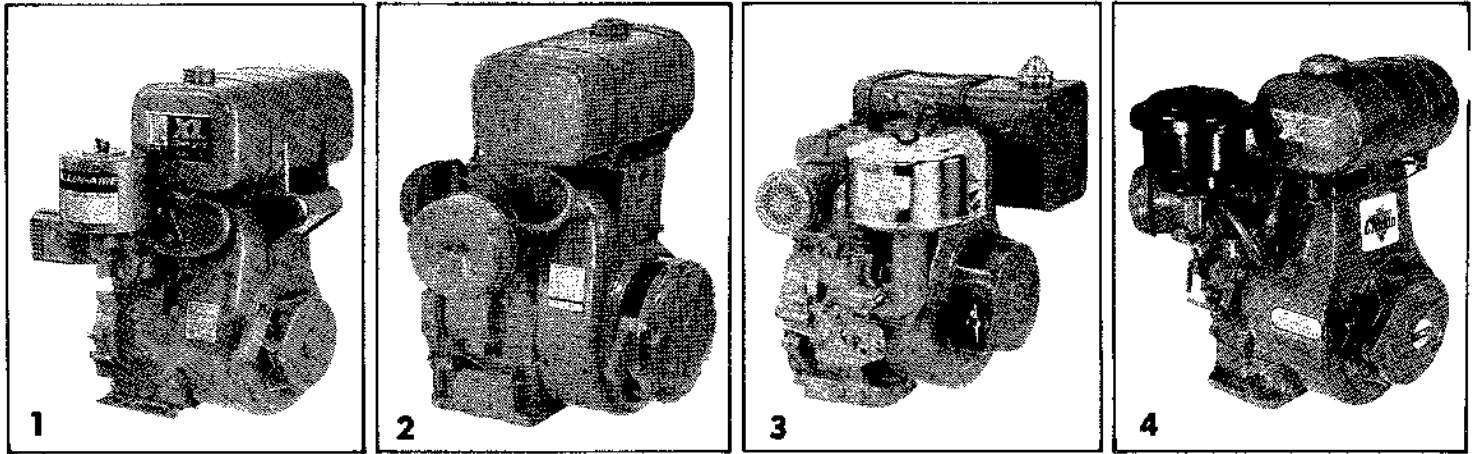

Here's How To Find Your Engine Model Numbers

**TECUMSEH-LAUSON
6 H.P. ENGINE**

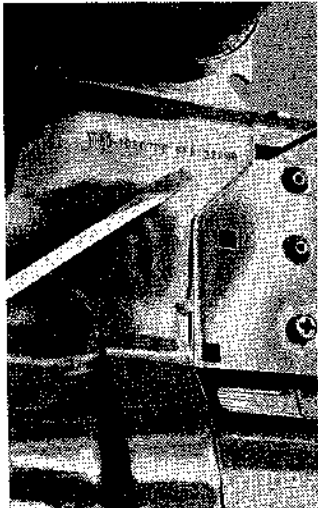

LOOK HERE . . . On the side of the engine blower housing opposite the starter rope.

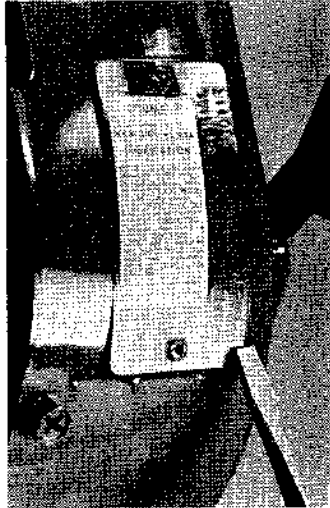

OR, LOOK HERE . . . Next to the lubrication instructions.

**CLINTON
4 1/2 H.P. ENGINE**

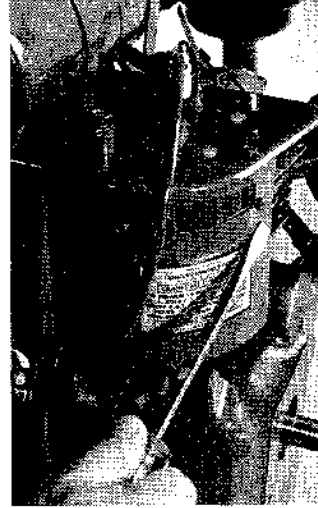

LOOK HERE . . . Screwdriver points to model and spec. nos. stamped (edge-wise) in red metal.

**KOHLER 7 H.P.
ENGINE**

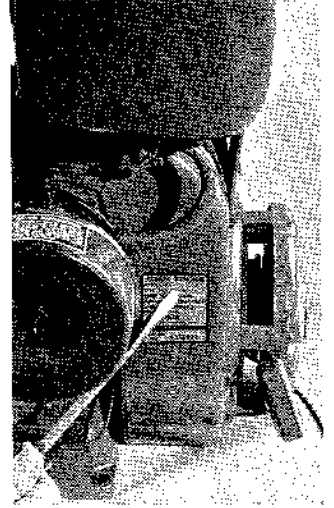

LOOK HERE . . . Model and spec. nos. on Kohler name plate.



**BRIGGS AND STRATTON
8 H.P. ENGINE**

LOOK HERE . . . on top of the blower housing between the chrome air cleaner and the chrome fuel cap.

INDEX NO.	PART NO.	DESCRIPTION ENGINES	NO. REQ'D	REPLACES
1	1870	ENGINE—6 HP Tecumseh, Model #HH-60, Specification #105115H, standard recoil starting , manual choke, dual element air cleaner, 1" crankshaft is turned down at power takeoff end to 3/4" to accept engine pulley. Engines have a cast iron cylinder block & crankcase. See Notes 1 & 2 below	1
1A	1868	ENGINE—6 HP Tecumseh, Model #HH-60, Specification #105116H, electric starting , manual choke, same as above but with electric start and automatic battery recharging system. For use with tillers already equipped with Key Switch Starting System (see Pages 28-29). The earlier, Push Button Starting System (see Pages 30-31) is not compatible with this engine. Also see Notes 1 & 2 below	1
1B	1869	ENGINE—6 HP Tecumseh, electric starting . Same as Part No. 1868 above, but comes with parts necessary to convert from Push Button Starting System to Key Switch Starting System. We are no longer able to stock an engine that is compatible with the Push Button System. See Note 1 below	1
2	1927	ENGINE—7 HP Kohler, "Professional," Model #K161T, Specification #281293. Standard recoil starting (electric start not available). Has remote throttle lever engine shutoff switch, introduced on Tiller Serial #599200 (see Note 3). Engine is cast iron, industrially rated, with bearings at both ends of crankshaft. Compression release. 1" crankshaft is turned down at power take off end to 3/4" to accept engine pulley. Must use special tine hood operating decal (Part #2156) which is supplied with replacement engines ordered from Garden Way	1
3	1838	ENGINE—8 HP Briggs & Stratton, "Professional," Model #195432, Type #0149-01, standard recoil starting . Manual choke, 1" crankshaft is turned down at power takeoff end to 3/4" to accept engine pulley. Engine has high silicon-copper aluminum alloy cylinder block with permanent cast iron cylinder sleeve, industrially rated, with bearings at both ends of crankshaft. ONLY TILLERS HAVING TILLER SERIAL NO'S. 384172 & UP, MADE AFTER MARCH 6, 1979, CAN SAFELY USE 8 HP ENGINES	1
3A	1839	ENGINE—8 HP Briggs & Stratton, "Professional," Model #195437, Type #0150-01, electric starting , manual choke, same as above but with electric start and automatic battery recharging system. ONLY TILLERS HAVING TILLER SERIAL NO'S. 384172 & UP MADE AFTER MARCH 6, 1979, CAN SAFELY USE 8 HP ENGINES	1
4	ENGINE—4½ HP Clinton, Model #498-0301-280, standard recoil starting , 1" crankshaft is turned down at power takeoff end to 3/4" to accept engine pulley. Cast iron block. No longer available from Garden Way. Can replace with Part No's. 1870 or 1927 (call Service Dept.)	1

ABOUT PROPANE ENGINES—Garden Way does not supply propane fueled engines. See your local Engine Service Dealers.

NOTE 1—All 6 HP Tecumseh engines are available with Manual Choke only. All 6 HP Electric Start engines are available with Key Switch Starting only. The automatic choke series and the Push Button Start system have been discontinued.

NOTE 2—Earlier Model Numbers of Tecumseh Engines supplied with Troy-Bilt Tillers are listed below. In most cases, number changes reflect design improvements by the engine manufacturer. Please note that some early tillers had aluminum engines at that time preferred by customers due to lower cost; these are listed separately.

NOTE 3—7 HP Kohler engines used on Tiller Serial #599199 & Below (Engine Model #K161T, Specification No's. 281291, 281287J, 281271J, 281148J, 281181) have an engine mounted Stop Button to shut off engine. This model engine no longer available from Garden Way, use Part #1927.

CAST IRON BLOCK ENGINES, USED FROM 1971 TO 1981

RECOIL START (Standard), or ROPE PULL WITHOUT RECOIL: HH 60 105041 C; 105049 C or D; 105061 D; 105079 D or E; 105090 E; 105101 F; 105106 F; 105106 G; 105113 G; 105113 H.

ELECTRIC START (12 Volt Battery & Starter Motor): HH 60 105049 E.S.; 105049 C, or E.S.; 105054, or C or D; 105080 D or E; 105091 E; 105102; 105103 F; 105107 F; 105107 G; 105114 G; 105114 H.

ALUMINUM BLOCK ENGINES, USED PRIOR TO 1968-69

RECOIL START (Standard), or ROPE PULL WITHOUT RECOIL: H 60 75173 D, E, G or L; 75251, or G or H; 75258 G.

ELECTRIC START (12 Volt Battery & Starter Motor): H 60 75165 E, F or G; 75173 L; 75250 E.S.; 75250 G; 75251 E.S.; 75259 G; 75273 G or H.

INDEX NO.	PART NO.	DESCRIPTION	NO. REQ'D	REPLACES
6 H.P. TECUMSEH KEY SWITCH ELECTRIC START SYSTEM				
1	9123	BATTERY—12 volt	1
2	9243	KEY—ignition	1
3	9230	KEY SWITCH	1
4	1552	RECEPTACLES, WIRE HARNESS & BATTERY RECHARGING WIRE, includes two receptacles, three red wires (with terminals), one green wire, plastic harness tube	1	1477, 1469
5	9255	BOOT—insulating, for battery and solenoid terminals	3
6	9265	TIE—twist, plastic	1	9202
7	9295	CABLE—battery, positive & negative cables	2	9124
8	9223	CABLE—solenoid to starter motor, small terminal at starter	1
9	9127	SOLENOID—electric start, includes nuts & washers for cables and wires	1
10	9218	CLIP—metal, supports battery recharging line	1
11	FUSE—6 amperes, 3 AGC (included with electric start 6 HP engine). Available locally or from Garden Way, Tec. #29561	1
12	DIODE—battery recharging (included with electric start 6 HP engine). For serviceman's replacement use Tecumseh Part No. 610935	1
13	1468	BATTERY HOLD-DOWN CLAMP & KEY SWITCH PLATE	1
14	9706	CARRIAGE BOLT—battery clamp, hex. head, 5/16"-18 x 9"	2
15	1169	BRACKET—battery mounting (welded)	1
16	9902	WASHER—plain, 5/16" S.A.E.	1	9901
17	9912	LOCKWASHER—5/16"	4
18	9801	NUT—hex., 5/16"-18	4
19	9826	NUT—hex., 5/16"-24	2
20	9723	SCREW—round head, 1/4"-20 x 3/4", solenoid mounting	2
21	9910	LOCKWASHER—1/4"	3
22	9800	NUT—hex., 1/4"-20	3
23	9921	LOCKWASHER—#10, center post on solenoid	1
24	9809	NUT—hex., 10-32, center post on solenoid	1
25	9713	BOLT—hex head, 3/8"-16 x 1 1/2", bracket to transmission cover (see Page 4, Index No. 66)	2
26	9913	LOCKWASHER—3/8" (see Page 4, Index No. 67)	2
27	9703	BOLT—hex head, 5/16"-18 x 3/4", cable to battery post	2
....	20418	DECAL—for key switch plate (Index No. 13)	1

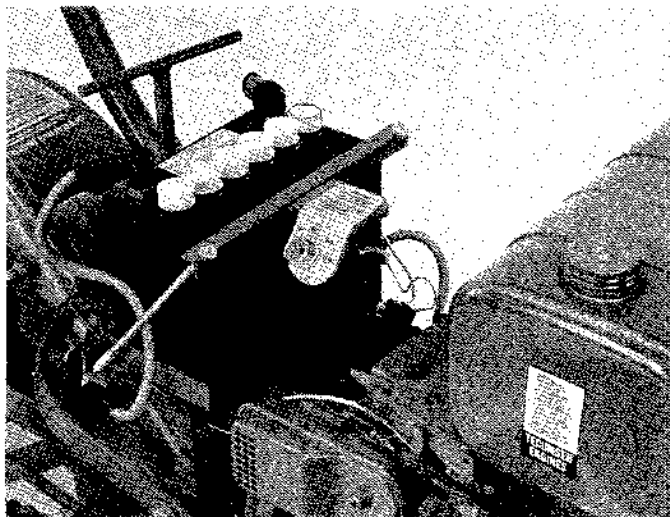

KEY SWITCH ELECTRIC START SYSTEM—Used on all electric start tillers with Tiller Serial No. 291333 and above. For earlier style, push-button system, see Pages 32 & 33.

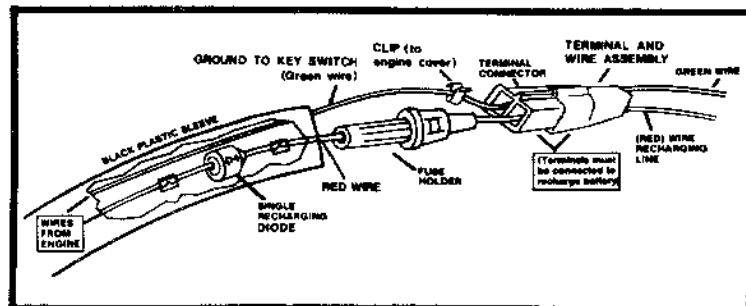

KEY SWITCH/SINGLE DIODE RECHARGING SYSTEM—To recharge battery, a small current from engine flows through diode and fuse, to the solenoid terminal and positive cable of the battery.

6 H.P. TECUMSEH ENGINE ELECTRIC START DIAGRAM

(USED ON ELECTRIC START TILLERS WITH TILLER SERIAL NO. 291332 & BELOW)

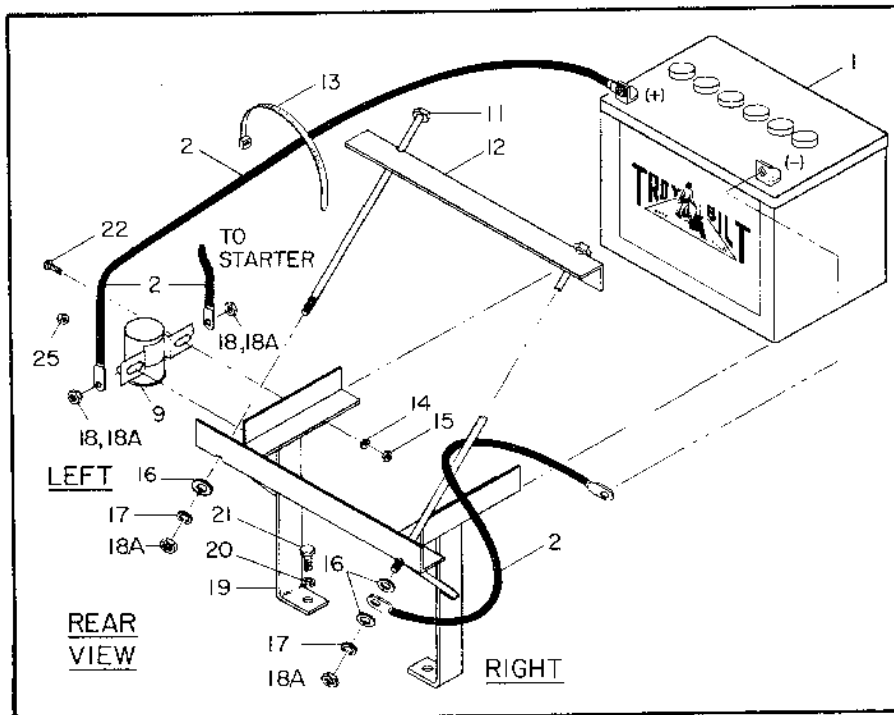
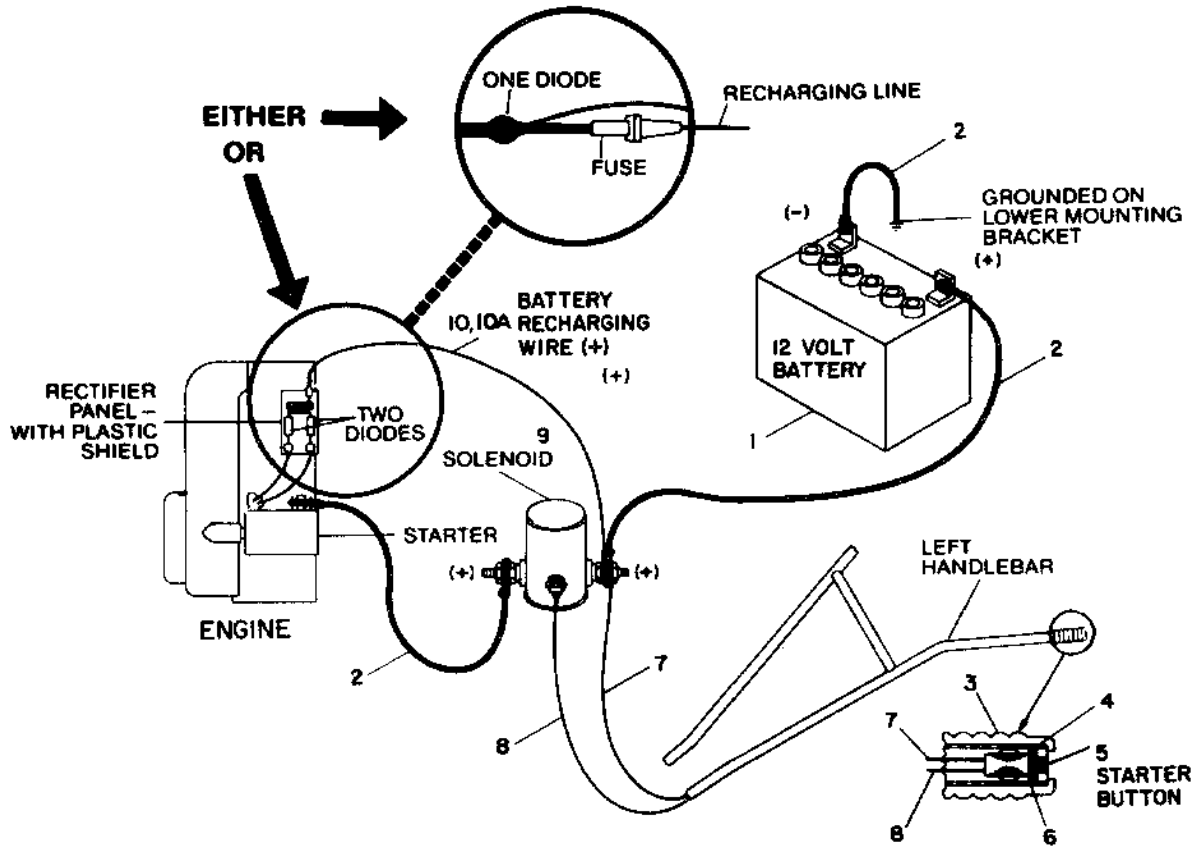

INDEX NO.	PART NO.	DESCRIPTION	NO. REQ'D	REPLACES
6 H.P. TECUMSEH PUSH-BUTTON ELECTRIC START SYSTEM				
1	9123	BATTERY—12 volt, 54 plates, 30 amps (7¾" long, 5¼" wide, 6" high)	1
2	9124	CABLE—battery	3
3	9141	GRIP—handlebar, left, electric start, includes Part No. 1180 spacer	1
4	1180	SPACER—starter button (included with grip Part No. 9141	1
5	9128	STARTER BUTTON ASSEMBLY	1
6	1229	WASHER—starter button, flat, 15/16" I.D., 1½" O.D.	1
7	1225	WIRE ASSEMBLY—solenoid to starter button (16 ga.) 59", ⅜" eyelet	1
8	1226	WIRE ASSEMBLY—starter button to solenoid (16 ga.) 59", #10 eyelet	1
9	9127	SOLENOID—electric start	1
10	1424	WIRE ASSEMBLY—with connecting terminal (solenoid to engine connector)	1
10A	1227	WIRE ASSEMBLY—engine rectifier panel to solenoid (16 gauge) 18", for two diode system	1
....	Tec 29561	FUSE—6 amps, 3 AG, ¼" dia. x 1 3/16" long, avail. locally, or from us	1
BATTERY MOUNTING BRACKET				
11	9706	CARRIAGE BOLT—battery clamp, hex. head, 5/16"-18 x 9"	2
12	1168	CLAMP—battery hold-down	1
13	9202	TIE—plastic, supports battery recharging line	1
14	9910	LOCKWASHER—¼", solenoid mounting	2
15	9800	NUT—hex., ¼"-20, solenoid mounting	2
16	9902	WASHER—plain, 5/16" S.A.E.	3	9901
17	9912	LOCKWASHER—5/16"	2
18	9826	NUT—hex., 5/16"-24, Tiller Serial No. 237764 & up	2	9801
18A	9801	NUT—hex., 5/16"-18, for carriage bolts (Index 11) on all tillers. On Tiller Serial No.'s 237763 and below, also used to attach cables to solenoid	4
19	1169	BRACKET—battery mounting (welded)	1
20	9913	LOCK WASHER—⅜" (see page 4, Indices 67 & 66)	2
21	9713	BOLT—hex. head, ⅜"-16 x 1½", bracket to transmission cover	2
22	9723	SCREW—round head, ¼"-20 x ¾", solenoid mounting	2
23	9218	CLIP—metal, supports battery recharging line, one included with Part #1424	2
25	9809	NUT—hex., 10-32, Part No. 1266 wire assembly to solenoid	1

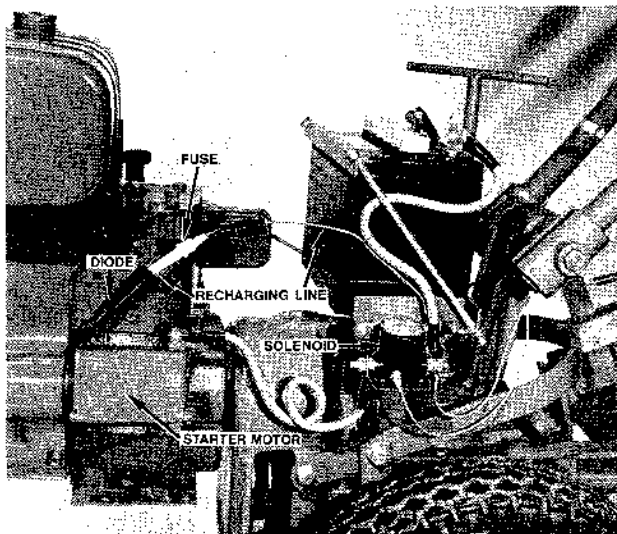

SINGLE DIODE RECHARGING SYSTEM — Used on electric start tillers with Tiller Serial No. 237764 through 291332.

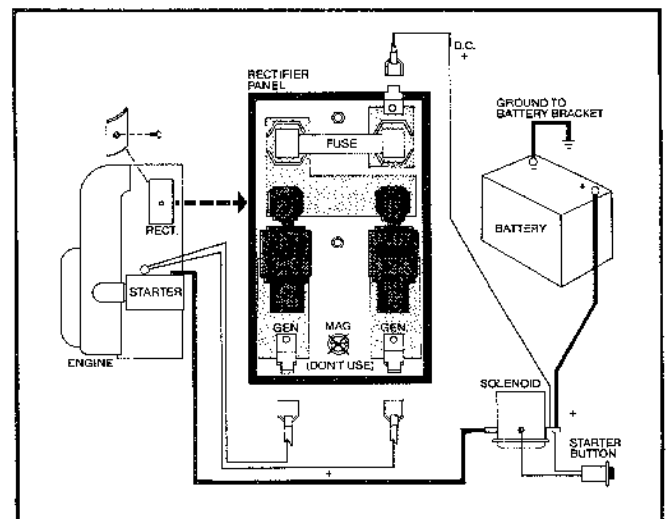

TWO DIODE RECHARGING SYSTEM—Used on all electric start tillers up to Tiller Serial No. 237763 (pushbutton starting). Parts shown in Rectifier Panel are supplied by engine service dealer or Garden Way.

8 H.P. BRIGGS & STRATTON ENGINE ELECTRIC START DIAGRAM

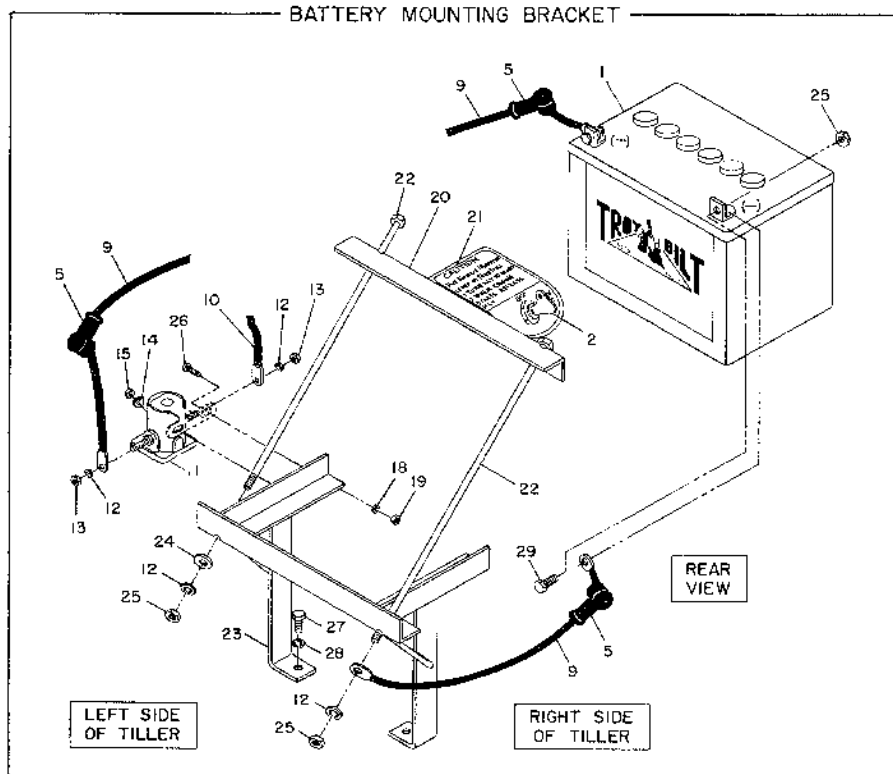
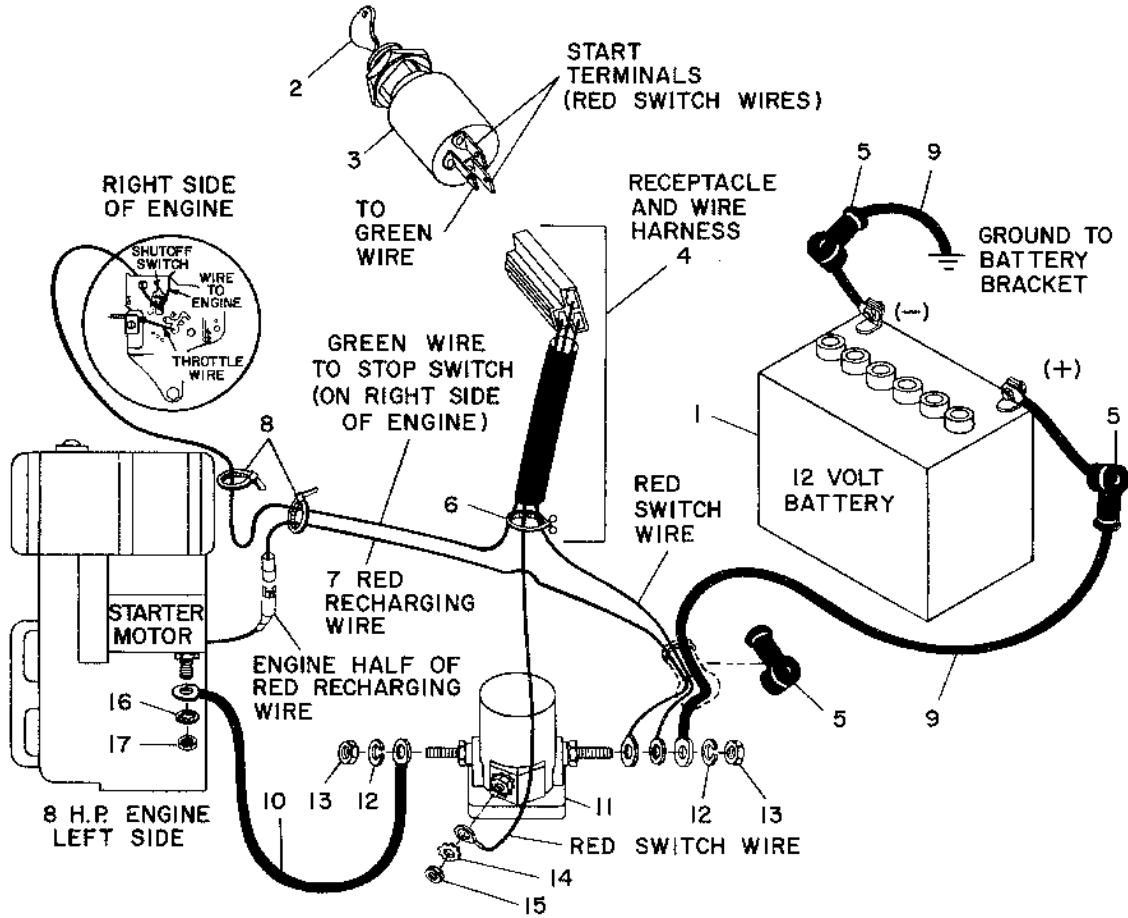

INDEX NO.	PART NO.	DESCRIPTION	NO. REQ'D	REPLACES
8 H.P. BRIGGS & STRATTON ELECTRIC START SYSTEM				
1	9123	BATTERY—12 volt, 30 ampere	1
2	9243	KEY—ignition	1
3	9230	KEY SWITCH	1
4	20424	WIRE HARNESS & CONNECTING TERMINALS ASSEMBLY—available as complete assembly only. Includes key switch receptacle with two red wires (with eyelets) and one green wire, plastic harness tube...	1
5	9255	RUBBER BOOT—terminal insulating	3
6	9265	TIE—red plastic, twist, wire retaining	1
7	1554	WIRE—recharging, red, includes terminal and eyelet for battery side of recharging line	1
8	9266	TIE—white plastic, reusable, wire retaining	2
9	9295	CABLE—battery, positive and negative terminals	2	9124
10	9223	CABLE—solenoid to starter motor	1
11	9127	SOLENOID—includes nuts and washers for cables and wires	1
12	9912	LOCKWASHER—5/16"	4
13	9826	NUT—hex., 5/16"-24	2
14	9921	LOCKWASHER—#10, external tooth, center post on solenoid	1
15	9809	NUT—hex., 10-32, center post on solenoid	1
16	LOCKWASHER—1/4", internal tooth, comes with engine. Not available from Garden Way	1
17	NUT—hex., 1/4"-20, comes with engine. Can be replaced with Part No. 9800, see Index #19 below	1
18	9910	LOCKWASHER—1/4", solenoid mounting	2
19	9800	NUT—hex., 1/4"-20, solenoid mounting	2
20	1468	BATTERY HOLD-DOWN CLAMP & KEY SWITCH MOUNTING PLATE ...	1
21	20418	DECAL—key switch instructions	1
22	9706	CARRIAGE BOLT—battery clamp, hex. head, 5/16"-18 x 9"	2
23	1169	BRACKET—battery mounting (welded)	1
24	9902	WASHER—plain, 5/16" S.A.E.	1	9901
25	9801	NUT—hex., 5/16"-18	4
26	9723	SCREW—round head, 1/4"-20 x 3/4", solenoid mounting	2
27	9713	BOLT—hex. head, 3/8"-16 x 1 1/2", bracket to transmission cover (also see Page 4, Index No. 66)	2
28	9913	LOCKWASHER—3/8" (also see Page 4, Index No. 67)	2
29	9703	BOLT—hex. head, 5/16"-18 x 3/4", cable to battery post	2

Tiller Attachments

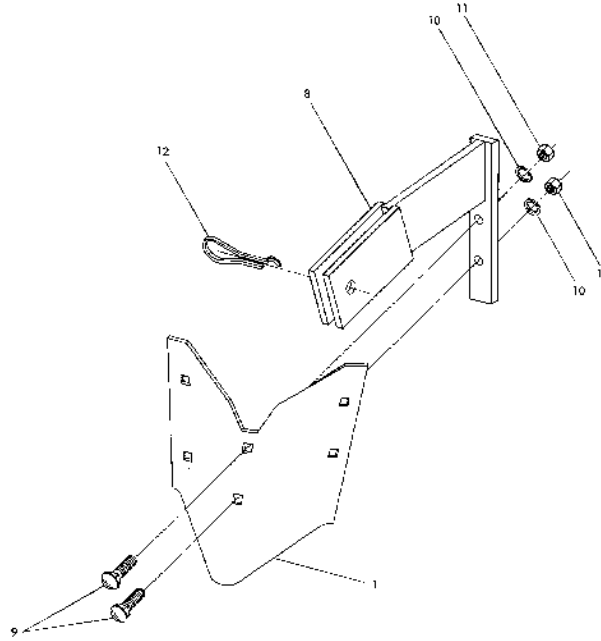

FURROWER ASSEMBLY

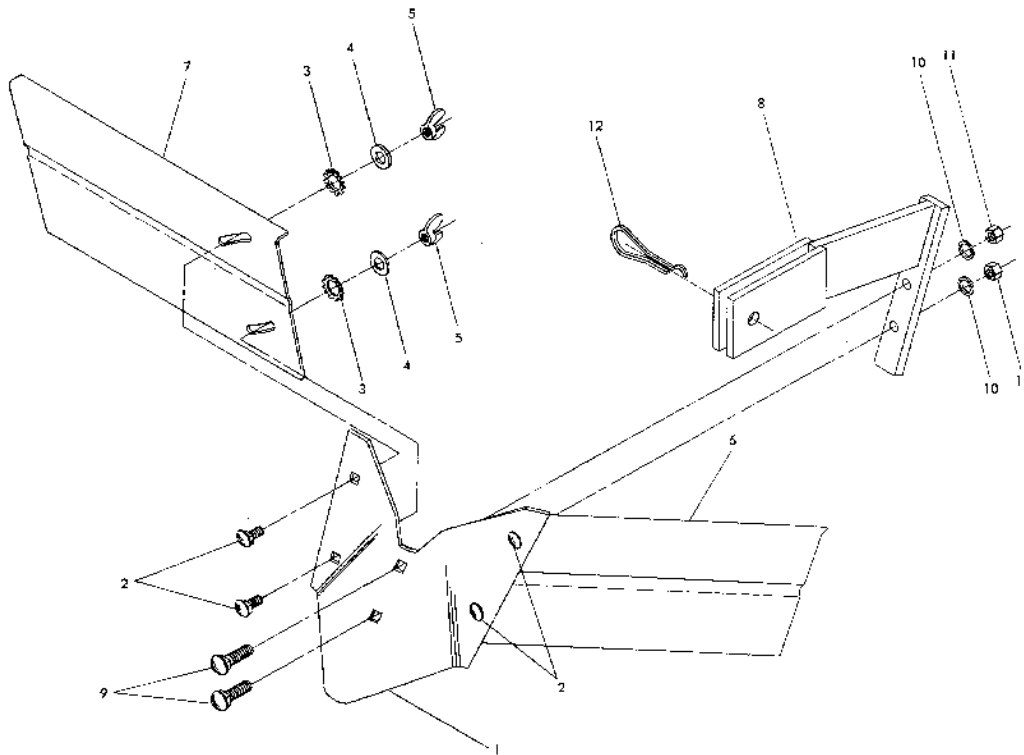

HILLER/FURROWER — Part #1317
(Viewed from front of tiller)

Tiller Attachments

INDEX NO.	PART NO.	DESCRIPTION	NO. REQ'D	REPLACES
HILLER/FURROWER — Part #1317				
COMPLETE ATTACHMENTS				
1	1269	FURROWER—blade only	1	9135
2	9765	CARRIAGE BOLT—5/16"-18 x 3/4"	4
3	9919	STAR WASHER—external tooth, 5/16"	4
4	9902	PLAIN WASHER—5/16" S.A.E.	4	9901
5	9824	WING NUT—5/16"-18	4
6	1299-1	HILLER WING—left	1
7	1299-2	HILLER WING—right	1
8	1197	BRACKET—blade mounting	1
9	9725	CARRIAGE BOLT—blade mounting, 3/8"-16 x 1 1/2"	2
10	9913	LOCKWASHER—3/8", plated	2
11	9802	NUT—hex., 3/8"-16, plated	2
12	9318	PIN—clinch	1
....	1317	HILLER/FURROWER—complete attachment (owner must bolt blade to mounting bracket, and wings to blade). Instructions included.	1

Tiller Attachments

DOZER/SNOW BLADE COMPLETE ATTACHMENT — Part #1873

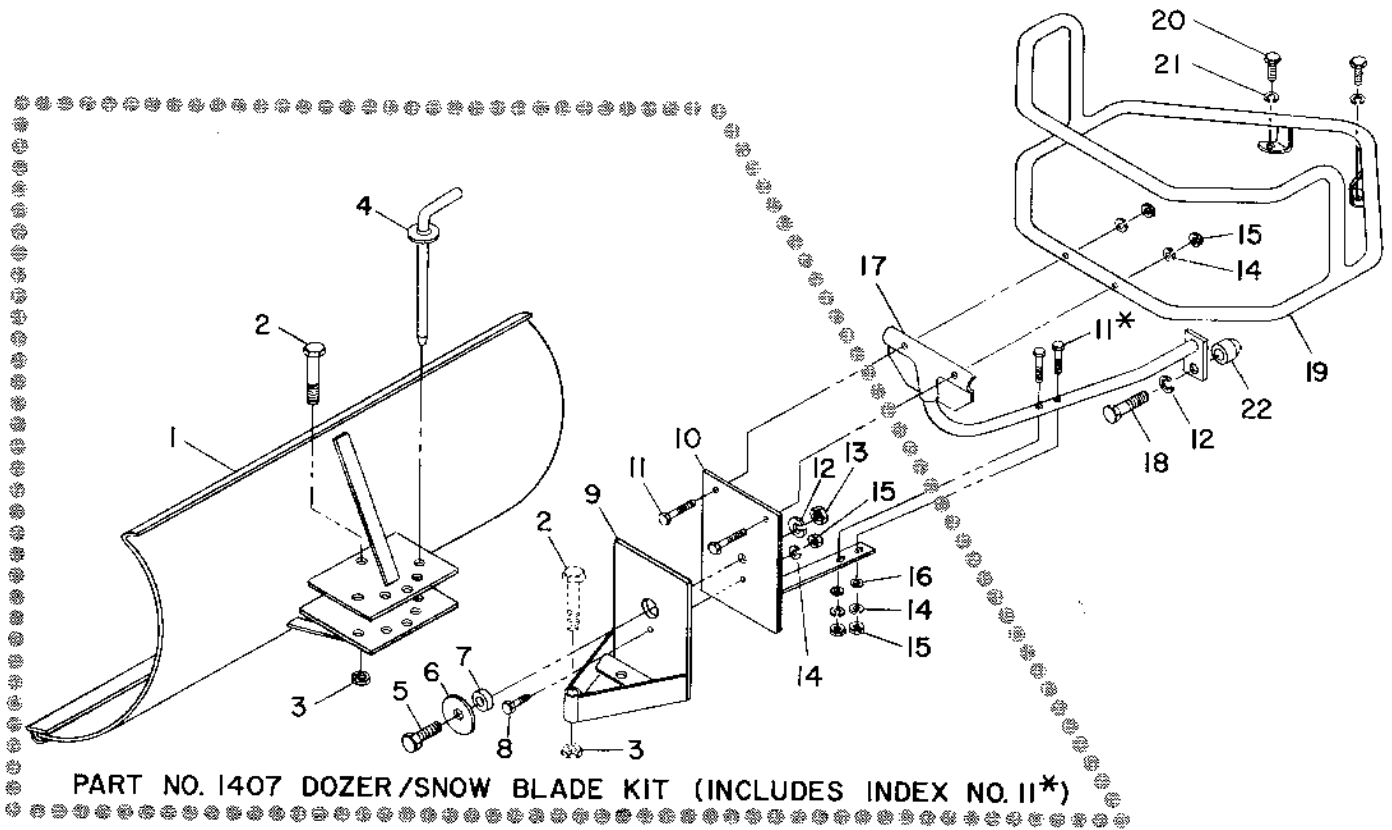

BUMPER ATTACHMENT — Part #1684

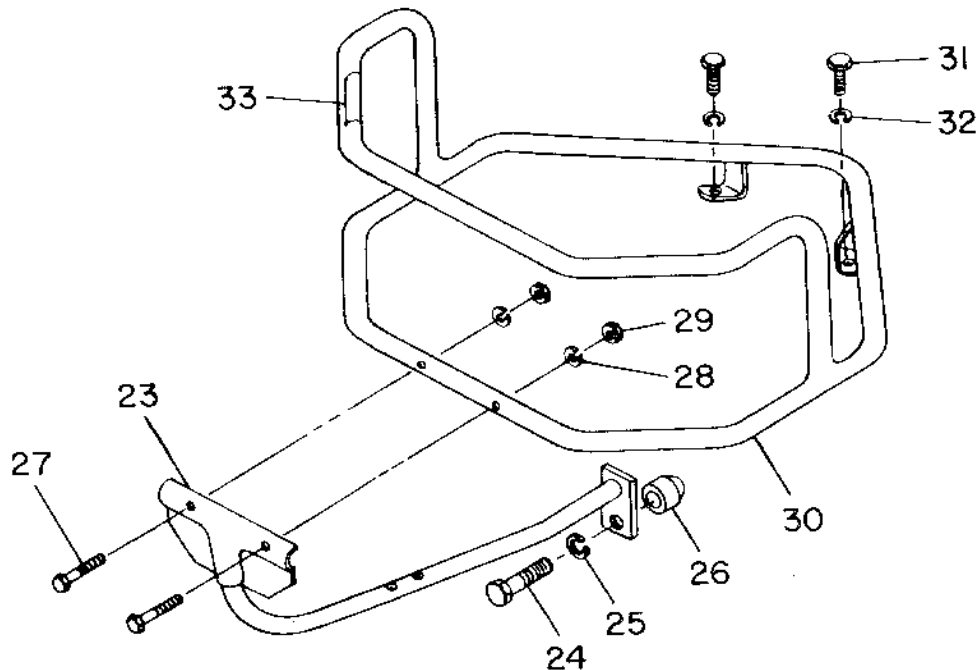

INDEX NO.	PART NO.	DESCRIPTION	NO. REQ'D	REPLACES
-----------	----------	-------------	-----------	----------

Tiller Attachments

DOZER/SNOW BLADE COMPLETE ATTACHMENT — Part #1873 (Part No. 1873 includes Index No's. 1 through 22, listed below)

1	1157	BLADE—dozer/snow blade	1
2	9717	BOLT—hex. head, ½"-13 x 3"	1
3	9804	LOCKNUT—hex., ½"-13	1
4	1158	PIN—index, blade angle adjustment	1
5	9767	BOLT—hex. head, ½"-13 x 1½"	1
6	9905	WASHER—plain, ½"	1
7	1416	BUSHING	1
8	9705	SCREW—hex. head, 5/16"-18 x 1¼"	1
9	1414	BRACKET—swivel ("A" frame)	1	1156
10	1415	BRACKET—dozer/bumper mounting	1
11	9759	SCREW—hex. head, 5/16"-18 x 1¾"	4
12	9914	LOCKWASHER—½"	2
13	9803	NUT—hex., ½"-13	1
14	9912	LOCKWASHER—5/16"	5
15	9801	NUT—hex., 5/16" x 18	5
16	9902	WASHER—plain, 5/16" S.A.E.	2	9901
17	1562	BRACE—bumper bottom (requires spacer, Part #1561—see Index 22, below)	1	1418
18	9716	BOLT—hex. head, ½"-13 x 2"	1
19	1683	BUMPER—wraparound	1	1417, 1558
20	9710	BOLT—hex. head, ¾"-16 x 1"	2
21	9913	LOCKWASHER—¾"	2
22	1561	SPACER—for bottom brace	1

BUMPER ATTACHMENT — Part #1684 (Part No. 1684 includes Index No's. 23 through 33, listed below)

23	1562	BRACE—bumper bottom	1	1418
24	9716	BOLT—hex. head, ½"-13 x 2"	1
25	9914	LOCKWASHER—½"	1
26	1561	SPACER—for bottom brace	1
27	9758	SCREW—hex. head, 5/16"-18 x 1½"	2
28	9912	LOCKWASHER—5/16"	2
29	9801	NUT—hex., 5/16"-18	2
30	1683	BUMPER—wraparound	1	1417, 1558
31	9710	BOLT—hex. head, ¾"-16 x 1"	2
32	9913	LOCKWASHER—¾"	2
33	1448	DECAL—for bumper	1

DOZER/SNOW BLADE KIT — PART #1407 (Shown within dotted area on Page 36)

Order Part #1407. For those who have already purchased a bumper (Part #1419, #1563, or #1684) and want to add a dozer/snow blade. Kit includes the following parts (see Descriptions and No. Req'd. on this page): Part No's. 1157, 9717, 9804, 1158, 1414, 1416, 9767, 9905, 9914, 9803, 1415, 9759, 9912, 9801, 9705 and 9902.

Tiller Attachments

INDEX PART NO. NO. DESCRIPTION NO. REQ'D REPLACES

ROW MARKER ATTACHMENT — Part #1832

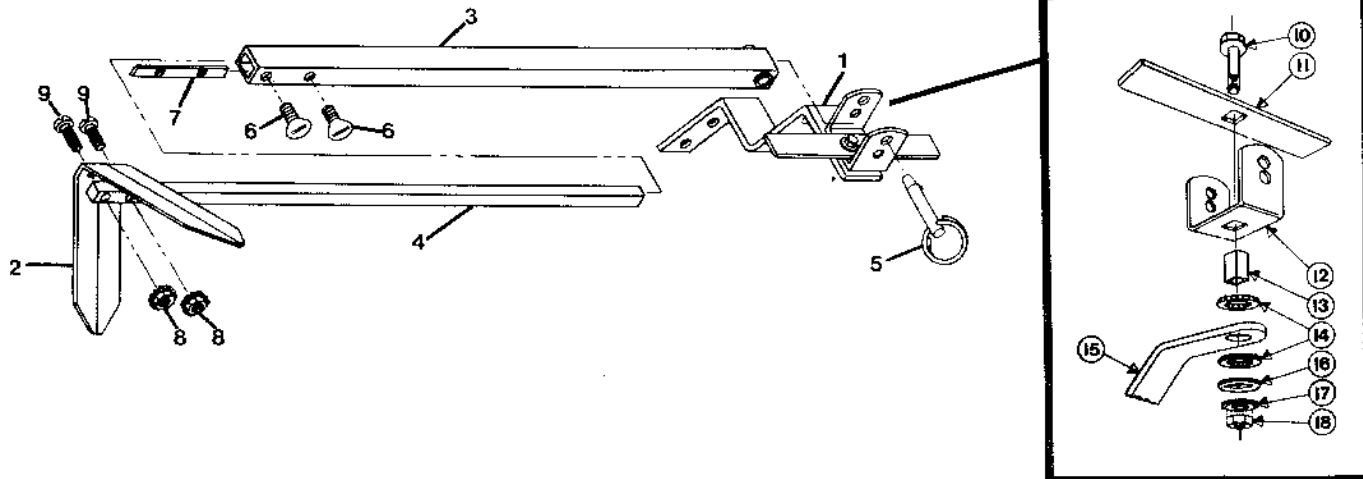

Main Support/Yoke Assembly
Part #1569

ROW MARKER ATTACHMENT — Part #1832 (Complete — Attaches to Part #1200 Furrower Attachment)

1	1569	MAIN SUPPORT & YOKE ASSEMBLY—complete. Incl. Index No's. 10 through 18 listed below	1
2	1594	MARKER BLADE—blade only	1
3	1597	MARKER ARM—main arm	1
4	1570	MARKER ARM—extension arm with stop pin	1
5	9347	HITCH PIN—included in #1837 Hardware Package	1
6	9786*	THUMBSCREW—1/4"-20 x 1/2", included in #1837 Hardware Package	2
7	1596	NUT BAR—included in #1837 Hardware Package	1
8	9828*	NUT—hex, 10-24 with attached star washers (see #1837 Hdw. Pkg.)	2
9	9721*	SCREW—round hd., 10-24 x 1", included in Hardware Pkg.	2
....	1837	HARDWARE PKG.—includes: one #9347 Hitch Pin, two #9786 Thumb-screws, one #1596 Nut Bar, two #9828 Hex Nuts, two #9721 Screws	1
....	1850	ROW MARKER & HILLER/FURROWER ATTACHMENT COMBINATION—complete. Includes: #1317 Hiller/Furrower and #1832 Row Marker	1

ROW MARKER MAIN SUPPORT & YOKE ASSEMBLY — Part #1569

10	9784	BOLT—flanged, self-locking, 3/8" -16 x 1 1/2"	1
11	1593	STOP BAR	1
12	1592	YOKE	1
13	1591	TUBE KEY—square	1
14	1590	WASHER—friction	2
15	1588	MAIN SUPPORT	1
16	1589	WASHER—square hole	1
17	9925	WASHER—disc spring	1
18	9802	NUT—hex, 3/8" -16	1

*Hardware is not available separately. These common hardware items can be easily found at local hardware stores.

Tiller Attachments

INDEX PART
NO. NO.

DESCRIPTION

NO.
REQ'D REPLACES

SOD POINT ASSEMBLY — Part #1307

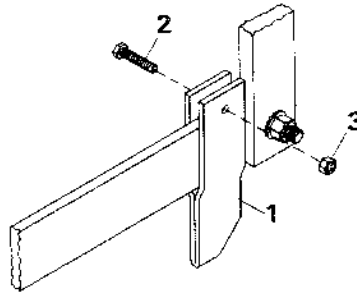

1	1294	SOD POINT	1
2	9701	SCREW—hex. head, 1/4" -20 x 3/4"	1
3	9811	LOCKNUT—hex., 1/4"-20	1
....	1307	SOD POINT ASSEMBLY—complete, includes #9701 screw, #9811 locknut, #1294 sod point	1

PARTS STILL AVAILABLE ON OLDER DOZER/SNOW BLADE

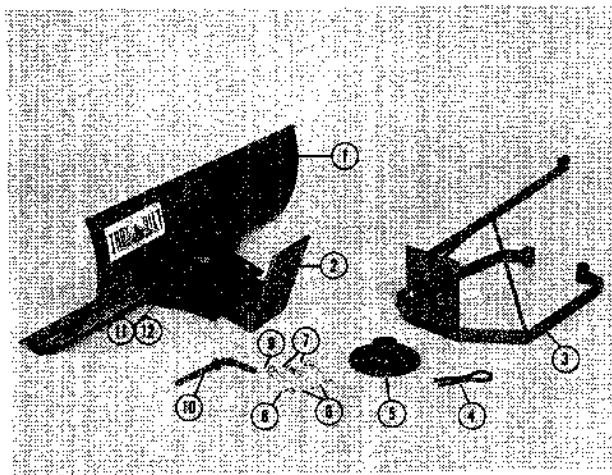

NOTE: The Part #1155 bracket (Index 3) is not as adequate protection as the new Bumper (Part #1684) — for instance, it won't protect the carburetor from being damaged.

1	1157	BLADE—dozer/plow	1
2	1156	BRACKET—swivel ("A" frame)	1
3	1155	BRACKET—"On-Off" attachment (available from factory until present stock is depleted)	1
4	1154	CLIP—retaining	1
5	1159	PLATE—blade retaining	1
6	9913	LOCKWASHER—3/8", plated	2
7	9714	BOLT—hex. head, 3/8"-16 x 2 1/4", plated	2
8	9914	LOCKWASHER—1/2", plated	1
9	9731	BOLT—hex. head, 1/2"-13 x 1 3/4", plated	1
10	1158	PIN—index, blade angle adjustment	1
11	9717	BOLT—hex. head, 1/2"-13 x 3", plated	1
12	9804	LOCKNUT—hex., 1/2"-13	1

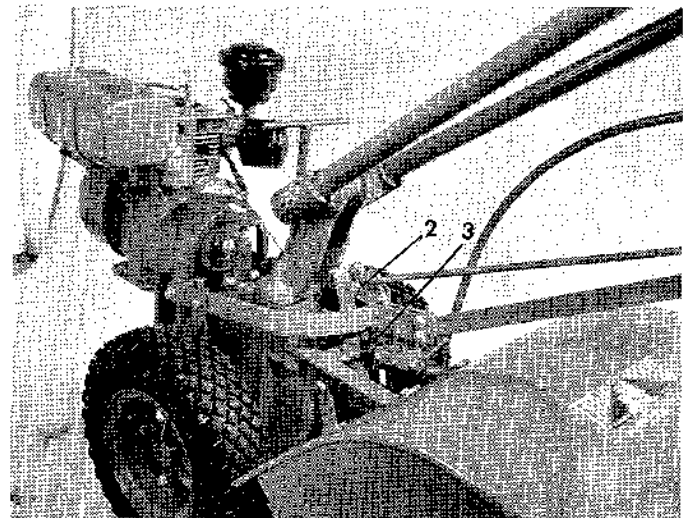
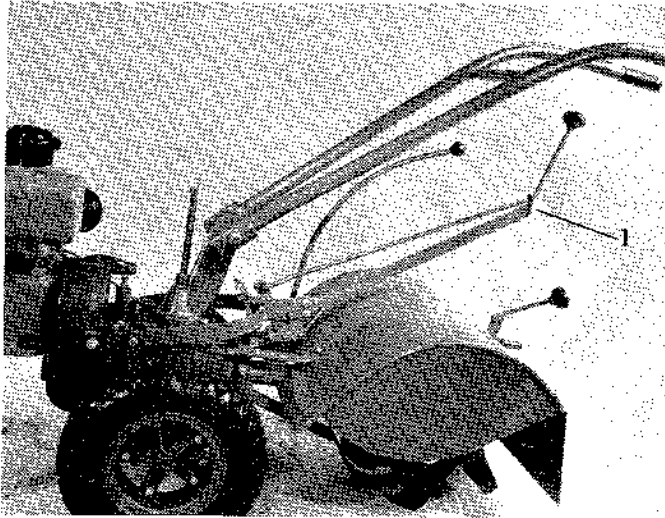

CHOPPER TINES FOR OLDER TILLERS

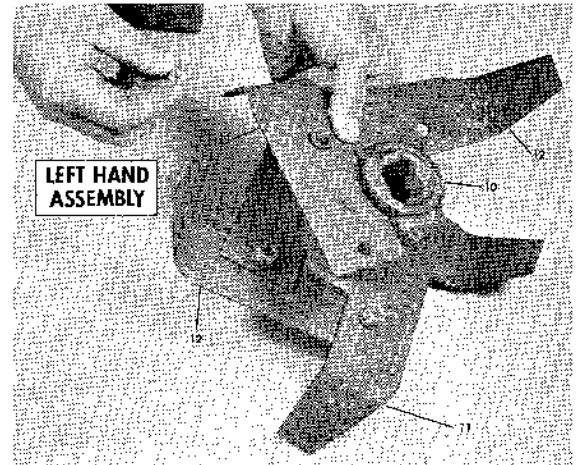
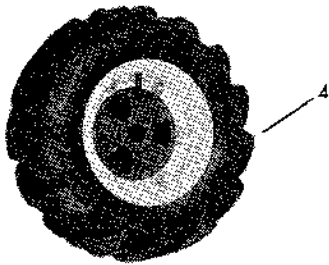

LEFT HAND ASSEMBLY

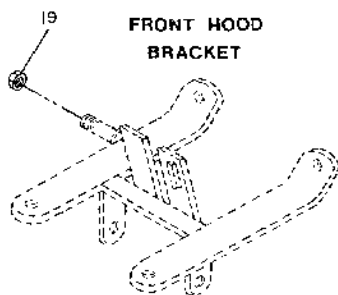
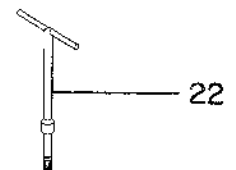
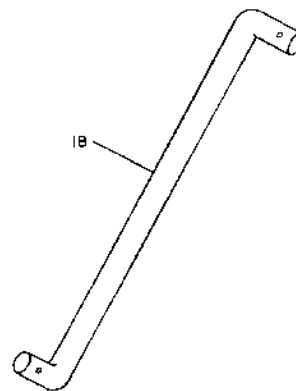
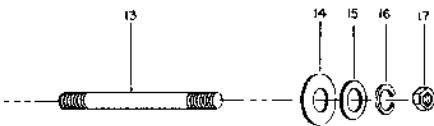
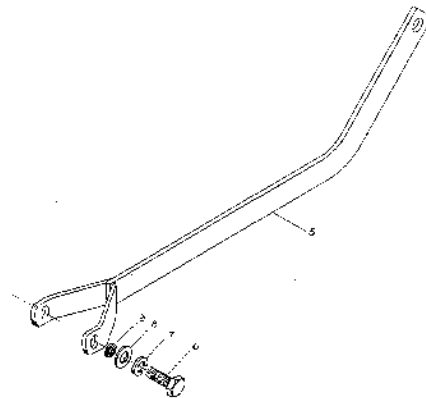

FRONT HOOD BRACKET

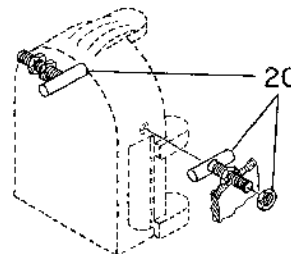

INDEX NO.	PART NO.	DESCRIPTION	NO. REQ'D	AVAILABLE
NON-CURRENT PARTS				
1	1040	CLUTCH LEVER—two piece assembly, used with #1038, two #1038-2, and #1096 knob (large). Use #1077 bracket, #1037 yoke, #1134 lever, #1042 roller assembly, and #1133 block	No
2	1079	BLOCK—reverse, use #1133 block & #1077 bracket	1	No
3	1078	BLOCK—shift, forward/neutral, belt adjustment	1	No
4	BAR TREAD TIRE & WHEEL—5:00 x 8, not available use 4:00 x 8 Bar Treads, see page 16, Index 13	No
5	1116	DRAG BAR—depth regulator, tiller serial No. 24574 & below, used with parts listed below under Index No.'s 6, 7, 8 & 9. This part is available for replacement purposes. Also, see page 14, Index 23 & 23A and page 14, Note 1	1	Yes
6	9705	BOLT—hex. head, 5/16"-18 x 1 1/4"	2	Yes
7	9912	LOCKWASHER—5/16"	2	Yes
8	9902	WASHER—flat, 5/16" S.A.E.	2	Yes
9	1113	BUSHING—spacer, pivot	2	Yes
10	1048	HOLDER—chopper tines	2	Yes
11	1049	TINE—chopper, right hand	8	Yes
12	1050	TINE—chopper, left hand	8	Yes
13	1047	STUD—chopper tines, 6"	2	Yes
14	9908	WASHER—flat, 5/8", standard size, outer diameter 1 3/4"	2	Yes
15	9905	WASHER—flat, 1/2"	2	Yes
16	9914	LOCKWASHER—1/2"	2	Yes
17	9805	NUT—hex, 1/2"-20, tine holder stud, see Index 13	2	Yes
18	1032	ROD—connecting, prior to shift lever No. 1230, see note, page 25	1	No
19	9804	NUT—hex. head, 1/2"-13, self-locking, wheel shift lever	1	Yes
20	1099	GUIDE—belt, with nuts, for motor mounts used before Tiller Serial No. 18032 & below, one each side	2	Yes
22	1400 & 1401	CLAMP—"T" bar, handlebar mounting, formerly used with #1261 handlebar base, #1400 is 10 1/2", for use with recoil start engine. #1401 is 14 1/4", for use with electric start engine	1	

Numerical Index

HOW TO USE THIS INDEX

<i>Part No.</i>	<i>Page & Index No.</i>
1003	4-58 12-8

To find where this part appears ... look on this page ... for this index number ... also on this page ... for this number.

<i>Part No.</i>	<i>Page & Index No.</i>	<i>Part No.</i>	<i>Page & Index No.</i>
1002.....	See Part #1698	1072K.....	22-11B
1003.....	4-58, 12-8	1073.....	Mtg. plate comes with Part #1072
1004.....	4-29A		14-18
1005.....	4-26A	1076.....	14-12
1006.....	See Part #1237	1077.....	40-3
1007.....	22-10B	1078.....	40-2
1007-1.....	22-10A	1079.....	Use Part #1519
1008.....	14-4A	1082.....	4-24
1008-1.....	14-4	1086.....	See Part #1715
1016.....	4-32	1089.....	4-31
1017.....	16-5	1094.....	16-11
1018.....	16-4	1097.....	24-54A
1019.....	22-19	1098.....	40-20
1020-1.....	22-26	1099.....	4-52
1020-2.....	22-23	1104.....	4-28
1021-1.....	22-27	1112.....	14-22, 24-53, 40-9
1021-2.....	22-22	1113-1.....	4-2, 12-2
1023.....	See Part #1872	1114.....	4-10, 12-11
1024.....	9-5 & 15	1115.....	14-23A, 40-5
1025.....	4-25C	1116.....	14-17
1026A.....	4-51	1117A.....	Use Part #9136
1027A.....	4-33	1118.....	14-27
1029.....	4-36	1119.....	14-28
1030.....	See note 1, page 25	1120.....	12-19
1032.....	40-18	1121A.....	24-46A
1033.....	24-43	1122.....	4-57, 12-9
1034.....	22-7	1123.....	4-5, 12-4
1035.....	4-60	1124-2.....	4-42
1036.....	Use Part #1251	1126.....	22-18A
1037.....	24-51A	1128.....	4-53, 12-12
1040.....	40-1	1129-1.....	4-53, 12-12
1041.....	4-34	1129-2.....	4-40
1042.....	24-50	1132-1.....	4-40
1043.....	22-24	1132-2.....	4-40
1046A.....	24-35	1132-3.....	14-13A
1047.....	40-13	1133-1A.....	24-45
1048.....	40-10	1134A.....	24-58A
1049.....	40-11	1136.....	9-1 & 10,
1050.....	40-12	1138-1.....	14-34, 22-9
1051A.....	24-50A		22-9
1055.....	4-46A	1138-2.....	See Part #1270-1A
1056.....	4-43A	1142-1.....	See Part #1270-2A
1057.....	4-44A	1142-2.....	See Part #1881
1058.....	9-4A & 13	1150.....	39-4
1060A.....	4-37	1154.....	39-3
1061.....	Use Part #9309	1155.....	39-2
1063.....	9-8 & 20	1156.....	36-1, 39-1
1064.....	4-50	1157.....	36-4, 39-10
1065.....	9-3 & 12	1158.....	39-5
1066.....	9-9 & 21	1159.....	16-14
1067.....	9-19	1163.....	4-22
1068.....	9-18	1166-1.....	4-22
1069.....	9-17	1166-2, 3, 4, 5.....	22-24A
1070.....	9-14	1167.....	30-12
1072A.....	22-11A	1168.....	

Part No.	Page & Index No.	Part No.	Page & Index No.
1169	28-15, 30-19, 32-23	1561	36-22 & 26
1180	30-4	1562	36-17 & 23
1197	34-8	1563	See Part #1684
1205	18-5	1568	4-15
1206	Use Part #1735	1569	38-1
1207A	18-9	1570	38-4
1213	22-9A	1588	38-15
1219	9-6	1589	38-16
1220	9-4	1590	38-14
1221	4-44	1591	38-13
1222	4-46	1592	38-12
1223	4-29	1593	38-11
1224-1	4-9	1594	38-2
1224-2, 3	4-9	1596	38-7
1225	30-7	1597	38-3
1226	30-8	1683	36-19 & 30
1227	30-10A	1684	36
1229	30-6	1698	22-3
1230A	24-36A	1714	4-6, 12-3
1231	24-42	1715	4-48, 12-14
1232	4-26	1735	18-10
1233	4-43	1813	See Part #1873
1235A	4-25A	1832	38
1237	4-27	1837	38
1238	14-38	1838	26-3
1239	14-37	1839	26-3
1245K	19	1843	24-36
1246	19	1850	38
1251	4-59	1868	26-1A
1261	Use Part #1019	1869	26-1B
1268	4-12	1870	26-1
1269	34-1	1872	4-54, 12-13
1270-1A	18-4	1873	36
1270-2A	18-3	1878	4-25
1294	39-1	1879	4-25B
1299-1	34-6	1881	22-21
1299-2	34-7	1902	4-8
1307	39	1919	20-2, 22-11
1317	35	1920	14-13, 20-9
1343	Use Part #1813	1921	20-7, 24-51
1400	40-22	1927	26-2
1401	40-22	2100	14-39, 20-8
1407	36	2146	24-61
1414	36-9	2156	See Part #1239
1415	36-10	4763	14-23
1416	36-7	9109	16-6
1417	Use Part #1683	9110	16-7
1418	Use Part #1562	9111	16-16
1419	Use Part #1563	9112	16-17
1424	30-10	9113	16-15
1440	4-17	9115	24-30A
1441	4-16	9116	24-29
1442	4-14	9118	24-33
1448	36-33	9119	14-16, 22-20
1461	18-8	9120	24-59
1463	18-6	9121	Use Part #9147
1468	28-13, 32-20	9122	4-70, 12-18
1469	Use Part #1552	9123	28-1, 30-1, 32-1
1477	Use Part #1552	9124	30-2
1483	20-1, 22-10	9125	Use Part #9124
1484	14-4B, 20-4	9127	28-9, 30-9, 32-11
1488	20-6, 24-54	9128	30-5
1492	20-5, 24-46	9135	Use Part #1269
1496	4-59A	9136	22-20A
1519	14-15	9141	24-34, 30-3
1550	See Part #1902	9142	14-1
1552	28-4	9143	16-1A
1554	32-7	9144	16-1
1558	See Part #1683	9145	14-33

Part No.	Page & Index No.	Part No.	Page & Index No.
9146	16-21	9719	4-12A
9147	22-8	9721	38-9
9148	16-3	9722	Use Part #9733
9149	16-13	9723	14-19, 28-20, 30-22,
9150	16-13A		32-26
9202	30-13	9725	34-9
9218	28-10, 30-23	9726	4-68A, 12-16A, 14-29
9223	28-8, 32-10	9727	4-65 & 68, 12-7 & 16
9230	28-3, 32-3	9731	39-9
9240	24-30	9732	22-48
9243	28-2, 32-2	9733	24-31
9245	20-3, 22-18	9738	22-17
9255	28-5, 32-5	9751	4-63
9265	28-6, 32-6	9758	36-27
9266	32-8	9759	36-11
9295	28-7, 30-2, 32-9	9765	34-2
9300	4-55	9767	36-5
9301	4-13, 9-7 & 16, 14-5,	9773	4-12
	14-31	9780	4-7
9303	22-2	9784	38-10
9305	4-30A	9786	38-6
9307	4-69	9800	14-21, 28-22, 30-15,
9309	4-38		32-19
9310	22-6	9801	4-64, 14-26, 24-49,
9317	16-12, 24-40		28-18, 30-18A, 32-25,
9318	34-12		36-15 & 29
9322	14-6, 16-2	9802	14-14, 16-10, 18-1,
9323	24-58		24-56, 34-11, 38-18
9347	38-5	9803	22-28, 36-13
9357	4-30	9804	36-3, 39-12, 40-19
9400	See Part #1714	9805	18-15, 40-17
9401	See Part #1714	9806	24-37
9402	See Part #1715	9808	24-44
9403	See Part #1715	9809	28-24, 30-25, 32-15
9404	4-41	9811	39-3
9500	9-2 & 11, 14-3	9824	34-5
9501	4-23A	9826	28-19, 30-18, 32-13
9502	4-45	9828	38-8
9504	4-72	9831	4-61
9511	4-23	9902	14-35, 24-41, 28-16,
9558	4-62		30-16, 32-24, 34-4,
9600	4-1, 12-1		36-16, 40-8
9602	See Part #9616	9903	14-11
9603	4-35, 12-15A	9904	24-57
9604	4-39, 12-6	9905	18-13, 36-6, 40-15
9609	4-21, 12-5	9907	24-39
9611	4-18, 12-15	9908	18-12, 40-14
9616	4-47, 12-10	9909	24-32
9701	4-3, 39-2	9910	4-4, 14-20, 28-21,
9703	14-24, 28-27, 31, 32-29		30-14, 32-18
9704	4-63, 22-4A & 60	9911	4-11 & 19
9705	24-47, 36-8, 40-6	9912	14-25, 22-5, 24-48,
9706	28-14, 30-11, 32-22		28-17, 30-17, 31-17,
9707	22-4		32-12, 36-14 & 28, 40-7
9708	22-17B	9913	4-67, 14-8 & 10, 16-9 &
9709	16-18		19, 22-16, 24-55, 28-26,
9710	14-9, 24-52, 36-20 & 31		30-20, 32-28, 34-4 & 28,
9711	18-2		36-21 & 32, 39-6
9712	14-36, 16-8	9914	18-7 & 14, 24-38, 36-12,
9713	4-66, 14-7, 28-25		& 25, 39-8, 40-16
	30-21, 32-27	9915	22-25
9714	39-7	9919	34-3
9715	22-17A	9921	28-23, 32-14
9716	36-18 & 24	9925	38-17
9717	36-2, 39-11	20418	29, 32-21
9718	4-56	20424	32-4

EXPLANATION OF "RIGHT HAND" & "LEFT HAND"
 Right Hand or Left Hand are determined by standing in the operator position and facing the direction of forward travel.

PLEASE NOTE:
 Illustrations of parts and components of your tiller in this Master Parts Catalog are shown consistently from a viewpoint on the left side of the tiller, in front of and slightly above the tiller and at a moderate angle (30 degrees). Nearly all of the illustrations use this reference position to view the part illustrated. However, in those circumstances where another view will provide more clarity, the drawing will also indicate that it is from another view, perhaps the rear view, for instance.

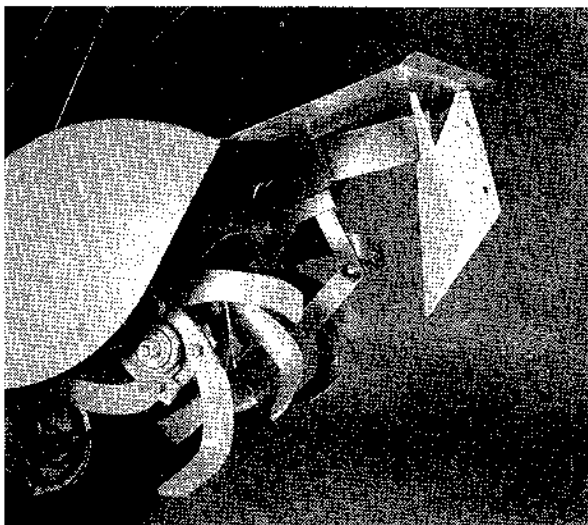

Furrower and mounting bracket on tiller.

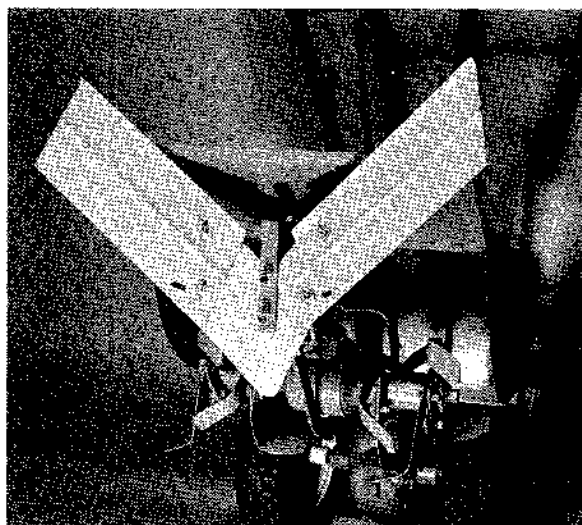

Hiller/Furrower has adjustable wings.



Setting out plants after using Furrower.



Hilling corn stalks with Hiller.



Using Dozer Blade for light grading.

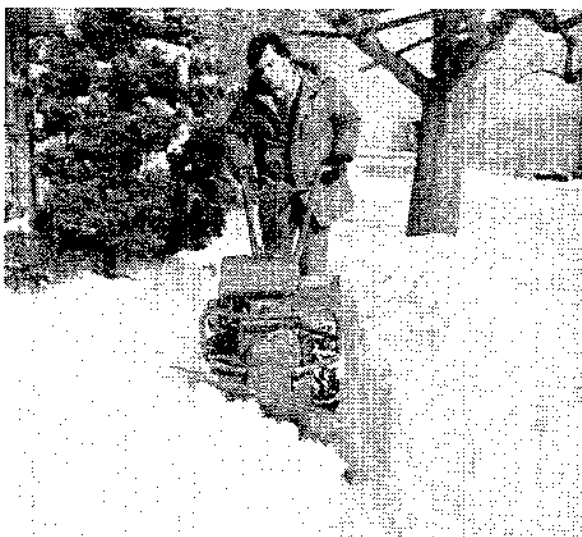

Clearing away snowfall with Dozer Blade.

For Discount Troy Bilt Parts Call 606-678-9623 or 606-561-4983

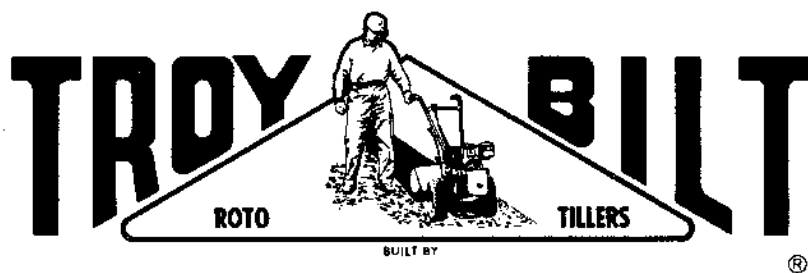

Garden Way Manufacturing Company

102nd Street & Ninth Avenue

Troy, New York 12180

1-800-833-6990