

21A-662D066 250cc Roto-Tiller (2009)
Drive System

Page 2 of 12

Ref #	Part Number	Qty	S/P/F	Description
1	710-0331	1	/P	Hex Screw, 3.8-24 x 2.25 Pony Models
1	710-0672	1	/P	Screw, 5.16-24 x 1.25 Proline Models
2	786-04070	1	S	Clutch Cable Bracket
3	936-0119	1	/P	Lockwasher, 5.16
4	710-0107	1	/P	Hex Head Screw, 5.16-24 x 1.2
5	731-05290	1	/P	Cover
6	712-3004A	1	/P	Flange Lock Nut, 5.16-18
7	714-0139	1	/P	Key, 3.16-2 Pony Models
7	914-0133	1	/P	Key, 3.16 x 1.5 Proline Models
8	736-04187	1	/P	Shim
9	619-04130	1	/P	Engine Pulley
10	936-0452	1	/P	Belle. Washer, .344 x 1.0 x .063 Pony Models
10	736-04193	1	/P	Belle. Washer .827 x .331 x .098 Proline Models
11	710-0672	1	/P	Hex Head Screw, 5.16.24 x 1-1.8
12	710-3103	1	/P	Hex Head Screw, 5.16.18 x 2
13	786-04276	1	/P	Reverse Idler Arm
14	1916535	1	/P	Reverse Idler Pulley
15	936-0159	1	/P	Flat Washer, 5.16
16	732-04081	1	/P	Wire Formed Belt Guide
17	710-0888	1	/P	Hex Head Screw, 5.16-24 x 1
18	934-04232	1	/P	Wheel Assembly, 13 x 5 x 6
19	736-3078	1	/P	Flat Washer, 1-1.8
20	732-04077	1	/P	Reverse Return Spring
21	619-04123	1	/P	Transmission Pulley
22	736-04079	1	/P	Support Washer
23	1918812	1	/P	Reverse Clutch Belt
24	1909404	1	/P	Forward Clutch Belt
25	1900396	1	/P	Self-tapping Screw, #10-32 x 1.2
26	GW-20673	1	S	Belts/Pulleys Guard
27	686-04067-0638	1	/P	Tine Holder
28	710-04043	1	/P	Hex Flange Screw, 5.16-18 x 3.4
29	1916797001	1	/P	Engine Support Bracket (left side)
30	786-04067-0637	1	/P	Engine Support Bracket (right side)
31	914-0133	1	/P	Key, 3.16 x 1.50
32	710-0395	1	/P	Hex Head Screw, 5.16.18 x 2-1.4
33	1918774001	1	/P	Mounting Bar
34	710-1260A	1	/P	Hex Flange Screw, 5.16-18 x .75
35	710-0805	1	/P	Hex Head Screw, 5.16-18 x 1-1.2
36	936-0275	1	/P	Flat Washer, 5.16
37	732-04082	1	/P	Belt Guide
38	GW-55088	1	/P	Pivot Bushing
39	712-04063	1	/P	Hex Lock Nut, 5.16-18
40	912-3010	1	/P	Hex Nut, 5.16-18
41	748-04087A	1	/P	Shoulder Washer
42	786-04275	1	S	Forward Tiller Direction Idler Arm
43	1767754	1	/P	Self-tapping Screw, #10-24
44	1916727	1	/P	Spring
45	912-3000	1	/P	Hex Locknut, 5.16-18
46	GW-9090	1	S	Forward Idler Pulley
47	710-0347	1	/P	Screw, 3.8-16 x 1-3.4

21A-662D066 250cc Roto-Tiller (2009)
Drive System

Page 3 of 12

Ref #	Part Number	Qty	S/P/F	Description
48	912-0158	1	/P	Hex Lock Nut, 5.16-18
49	1754128	1	/P	Screw, 1.4-20 x 3.4
50	936-0463	1	/P	Flat Washer, 1.4
51	736-04193	1	/P	Belleville Washer, .827 x .331 x .098
52	710-0514	1	/P	Hex Head Screw, 3.8-16 x 1
53	742-04223-0637	1	/P	Bolo Tine-single (Left)
54	749-04193-0637	1	/P	Bumper
55	710-0606	1	/P	Hex Head Screw, 1.4-20 x 1.5
56	710-3096	1	/P	Hex Head Screw, 3.8-16 x 2
57	712-04064	1	/P	Flange Hex Locknut, 1.4-20
58	742-04224-0637	1	/P	Bolo Tine-single (Right)

21A-662D066 250cc Roto-Tiller (2009)
Handle & Tine Shield

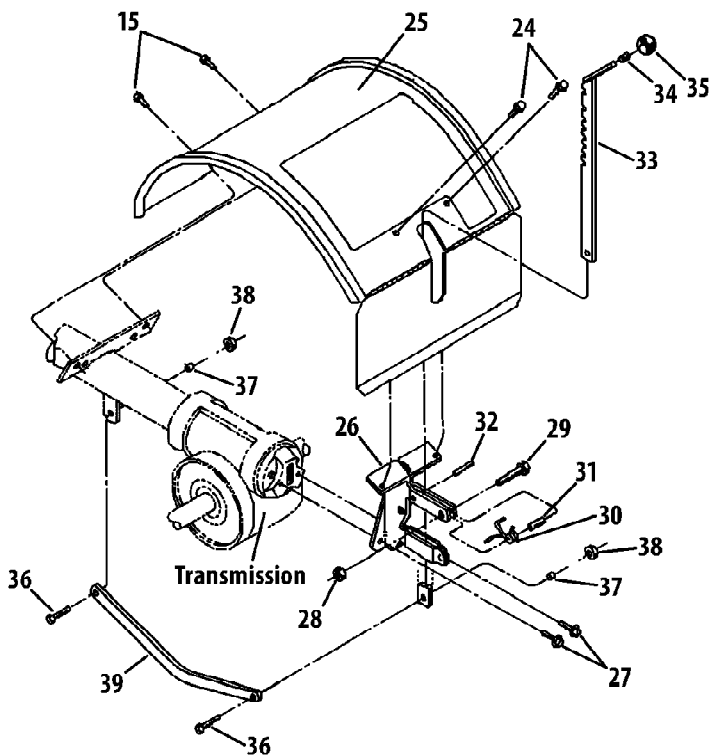
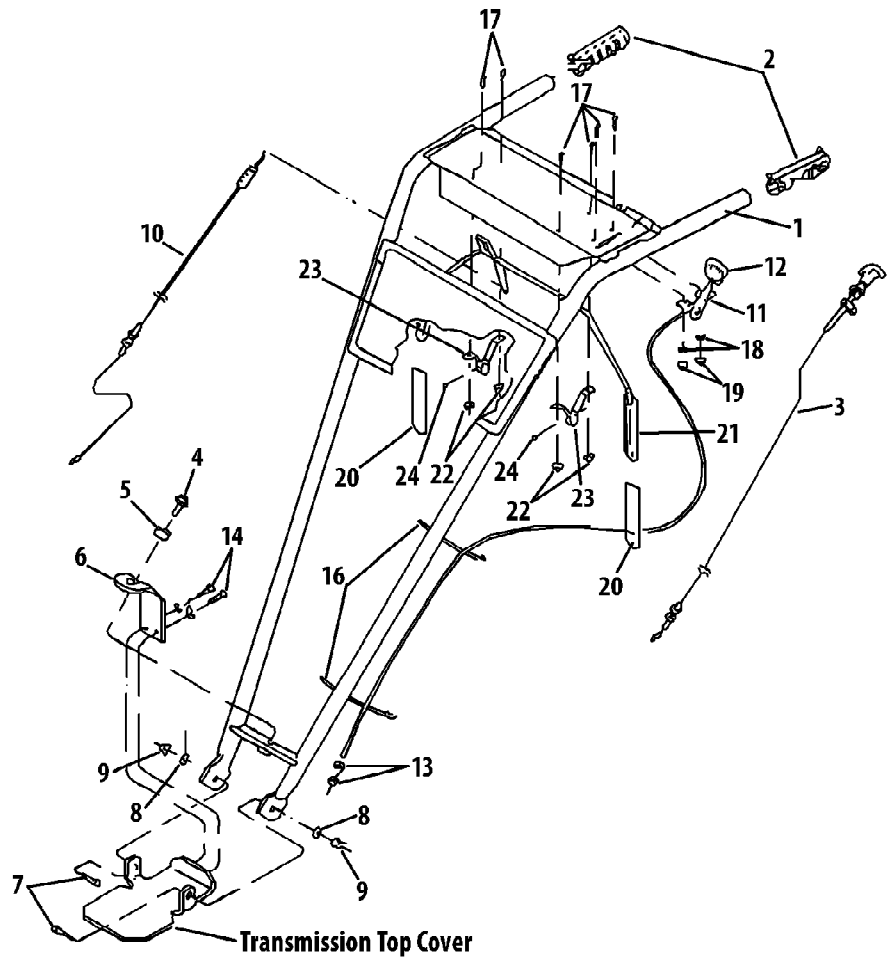

21A-662D066 250cc Roto-Tiller (2009)
Handle & Tine Shield

Page 5 of 12

Ref #	Part Number	Qty	S/P/F	Description
1	1918811P	1	/P	Handlebars
2	720-0274	1	/P	Grip
3	1916784	1	S	Reverse Clutch Control Cable
4	710-04042	1	/P	Hex Flange Screw, 3/8-16
5	GW-9955	1	S	Keyed Washer
6	1900475010	1	/P	Handlebar Hgt. Adjustment Bracket
7	710-0514	1	/P	Hex Hd. Screw, 3.8-16 x 1
8	736-3050	1	/P	Plain Washer, 3.8
9	912-3000	1	/P	Hex Locknut, 3.8-16
10	746-04027	1	S	Forward Clutch Control Cable
11	GW-9442	1	S	Wheel Gear Control & Cable Ass.
12	GW-9057	1	/P	Wheel Gear Control Lever Knob
13	1186211	1	/P	Hex Nut, 5.16-24
14	GW-90064	1		Hex Head Screw, 3.8-16 x 5/8
15	710-0759	1		Self-tapping Screw, 5.16-18 x 5.8
16	725-0157	1	/P	Cable Ties
17	1114748	1	/P	Round Head Screw, #10-32 x 1.2
18	936-0722	1	/P	Lockwasher, #10
19	1186208	1	/P	Hex Nut, #10-32
20	GW-9390	1	/P	Grip
21	1918840	1	/P	Forward Clutch Bail
22	GW-9853	1	/P	Sems Nut
23	GW-20806	1	/P	Bail Support Bracket
24	710-0599	1	/P	Self-tapping Screw, 1.4-20 x 1.2
25	686-04078-0638	1	/P	Tine Hood
26	GW-2525	1		Depth Regulator
27	710-04049	1	/P	Hex Flange Screw, 5.16-18 x 5.8
28	712-04064	1	/P	Hex Locknut, 1.4-20
29	710-0597	1	/P	Hex Head Screw, 1.4-20 x 1
30	732-04320	1	/P	Spring
31	750-04556	1		Spacer
32	715-04034	1	/P	Roll Pin (spiral), 1.4 x 1
33	1900864	1	/P	Depth Regulator
34	GW-9120	1	/P	Retaining Ring
35	GW-9119	1	/P	Depth Regulator Knob
36	710-3005	1	/P	Hex Head Screw, 3.8-16 x 1-1.4
37	GW-1113-1099	1	/P	Drag Bar Bushing
38	712-04065	1	/P	Hex Nut, 3.8-16
39	1916185001	1	/P	Drag Bar

21A-662D066 250cc Roto-Tiller (2009)
Label Map Pony

777122624



Model Plate

Tine Shield

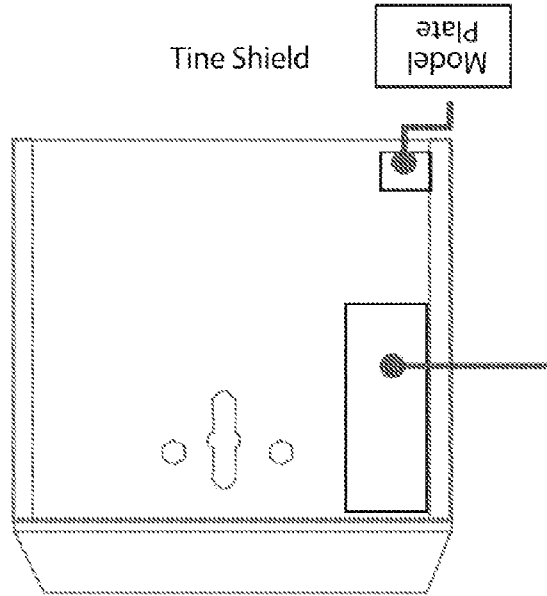

777S32660

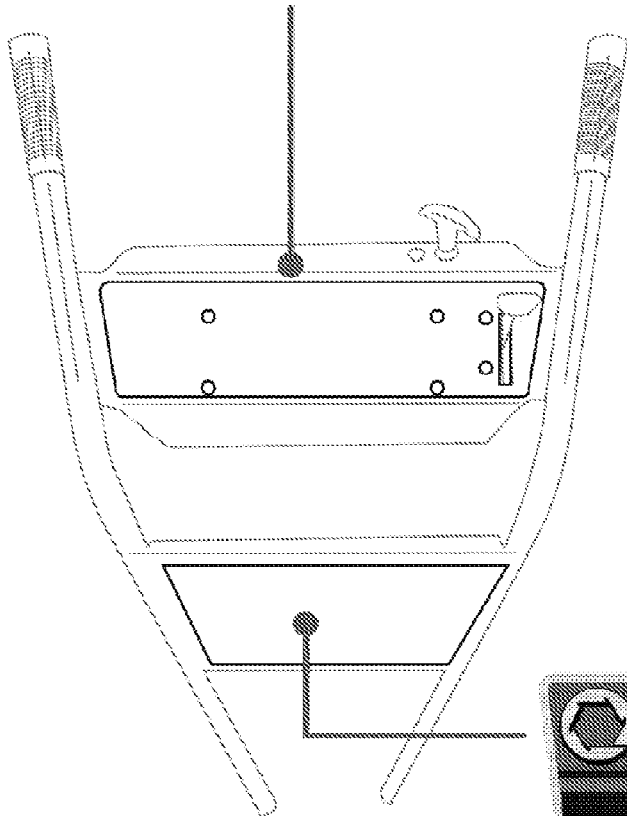
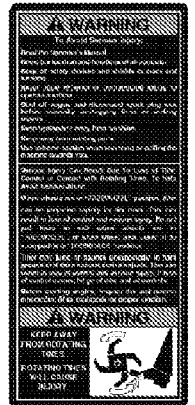

777D10809

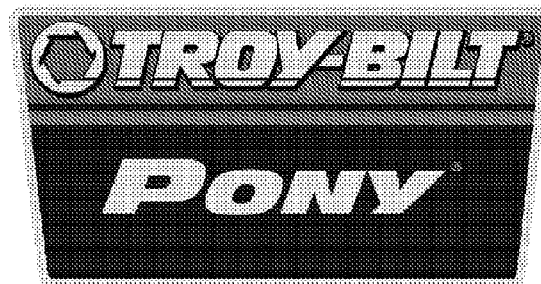

777X43688
Place near fuel cap

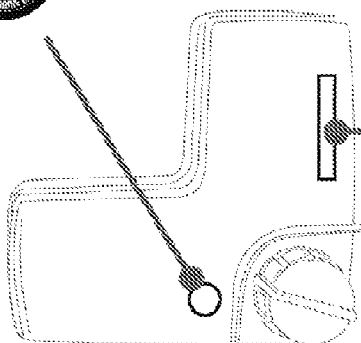

777120358
Place On Fuel Tank



21A-662D066 250cc Roto-Tiller (2009)
Label Map Pony

Page 7 of 12

Ref #	Part Number	Qty	S/P/F	Description
777I22624	777I22624	1		LABEL:TILLER HANDLE:660
777D10809	777D10809	1		LABEL-TILLER HANDLE PANEL:PONY
777X43688	777X43688	1		LABEL-ETHANOL
777I20358	777I20358	1		LABEL-PLACE HAND HERE
777S32660	777S32660	1		LABEL:TILLER TINE SHIELD

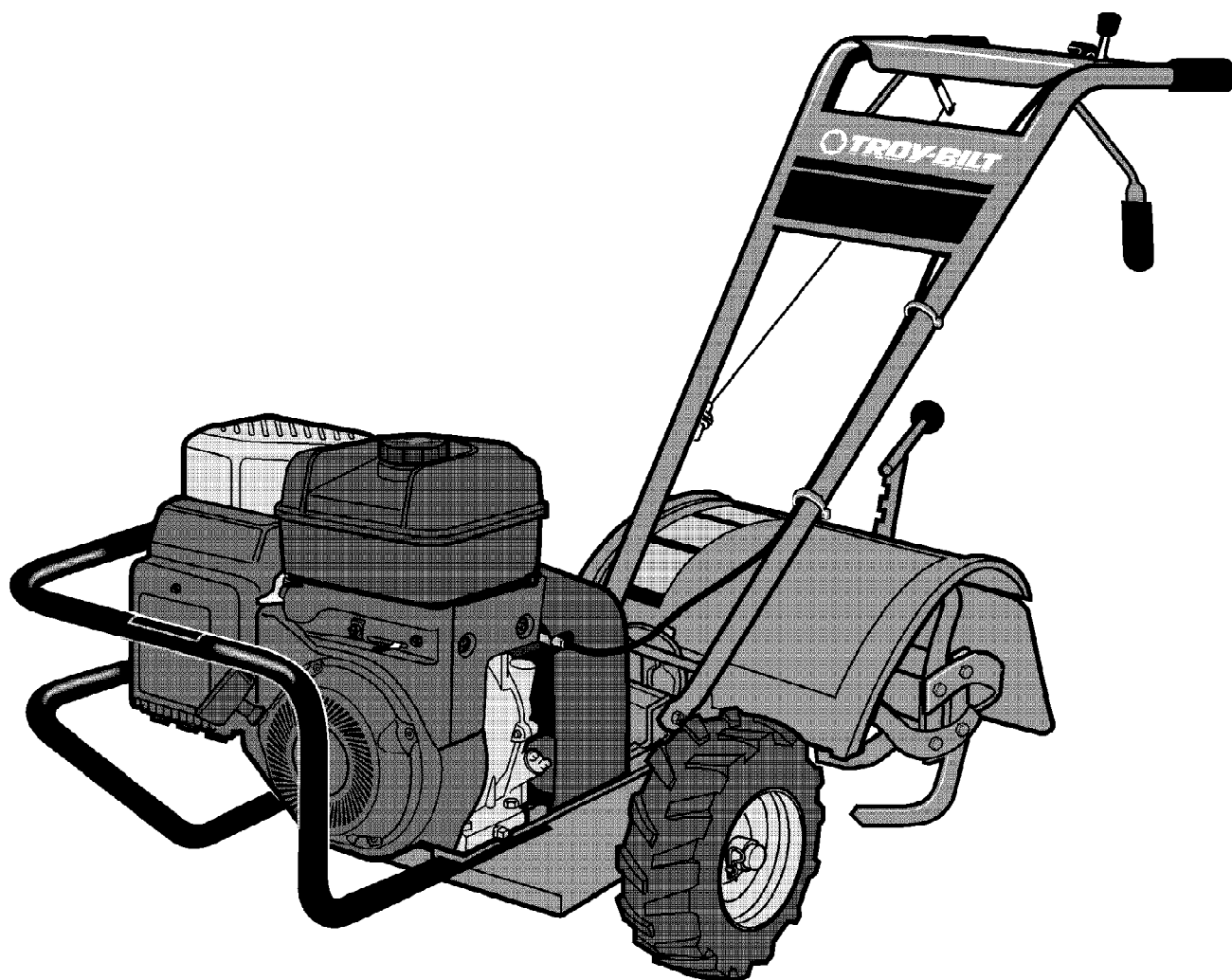

21A-662D066 250cc Roto-Tiller (2009)
Quick Reference

Page 9 of 12

Ref #	Part Number	Qty	S/P/F	Description
	759-3336	1	/P	Spark Plug - B&S
	BS-493537S	1	/P	Pre Filter - B&S
	BS-491588S	1	/P	Air Filter - B&S
	N/A	1		Fuel Filter - B&S
	490-250-0009	1		Spark Plug - Honda
	N/A	1		Pre Filter - Honda
	17218-ZE1-507	1		Air Filter - Honda
	17672-Z4H-000	1		Fuel Filter - Honda
	1909404	1	/P	Drive Belt - FWD
	1918812	1	/P	Drive Belt - REV
	GW-9090	1	S	Idler Pulley
	746-04027	1	S	Clutch Cable - FWD
	1916784	1	S	Clutch Cable - REV
	742-04223-0637	1	/P	Tines - LH
	742-04224-0637	1	/P	Tines - RH
	934-04232	1	/P	Wheel Assembly
	720-0274	1	/P	Foam Grip
	N/A	1		Shift Control Knob
	GW-9119	1	/P	Handle Knob

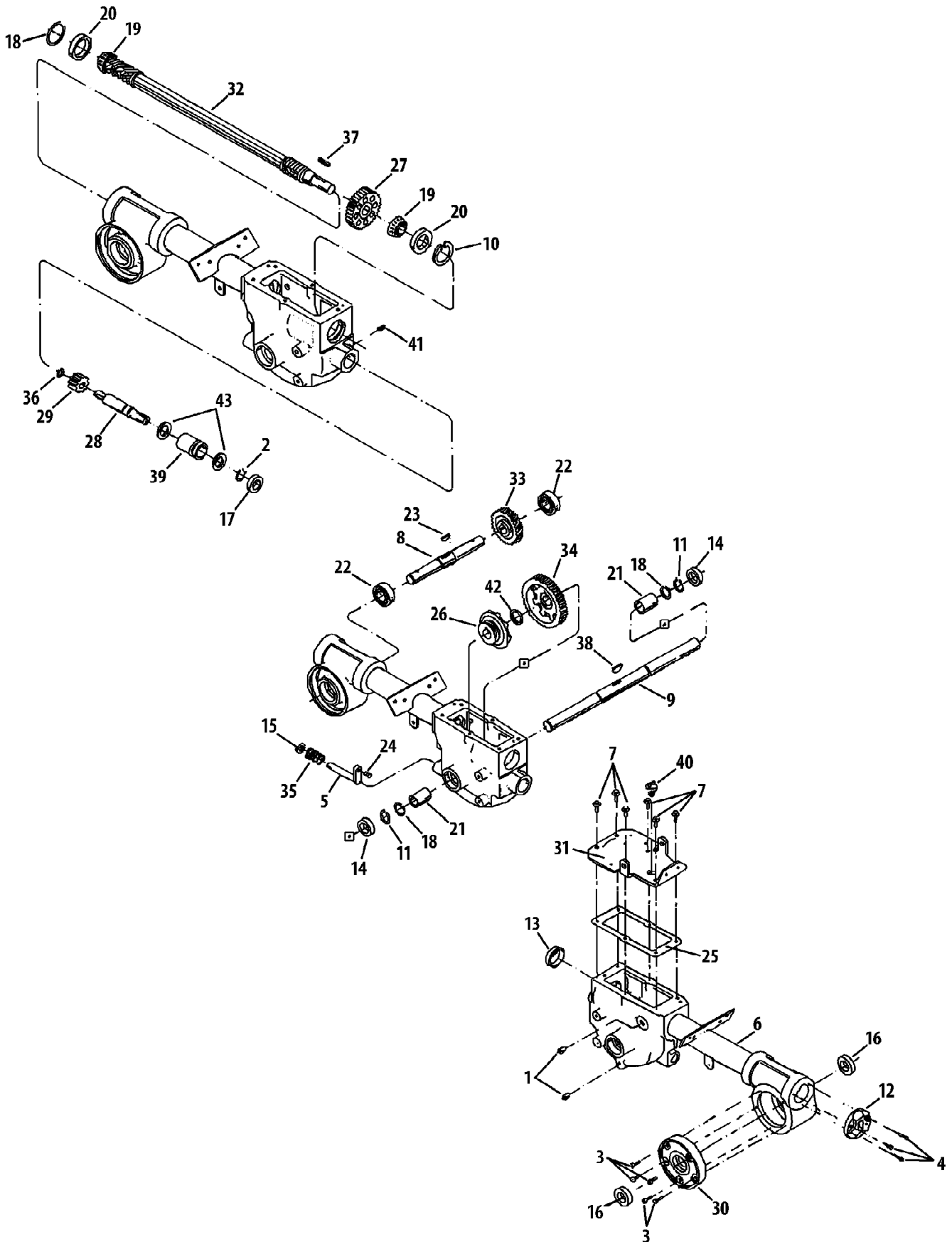

Ref #	Part Number	Qty	S/P/F	Description
1	1105620	1	/P	Pipe Plug
2	916-0101	1	/P	Retaining Ring
3	1915068	1	/P	Hex Screw, 1.4-20 x .625
4	1915069	1	/P	Self-Sealing Screw, 1.4-20 x .875
5	611-04002	1	/P	Eccentric Shaft
6	919-04010	1	/P	Transmission Housing
7	710-04043	1	/P	Hex Flange Screw, 5.16-18 x .750
8	GW-20896	1	/P	Tiller Shaft
9	911-04482	1	/P	Wheel Shaft
10	716-04102	1	/P	Retaining Ring
11	716-04104	1	/P	Retaining Ring
12	718-04406	1	/P	Rear Bearing Cover
13	721-04001	1	/P	Oil Seal, 1.79 x .25
14	921-04031	1	/P	Oil Seal, 1.0 x 1.499
15	921-04034	1	/P	Oil Seal, .625 x 1.0
16	921-04035	1	/P	Oil Seal, .984 x 1.75
17	921-04044	1	/P	Oil Seal, .750 x 1.25
18	736-04258	1	/P	Washer, 1.375 x 1.015 x .01 Washers of multiple thickness are used as required to obtain a thickness of .005" to .015" of allowable end-play in the drive shaft.
18	736-04259	1		Washer, 1.375 x 1.015 x .015 Washers of multiple thickness are used as required to obtain a thickness of .005" to .015" of allowable end-play in the drive shaft.
18	736-04260	1		Washer, 1.375 x 1.015 x .03 Washers of multiple thickness are used as required to obtain a thickness of .005" to .015" of allowable end-play in the drive shaft.
18	736-04305	1	/P	Washer, 1.75 x 1.5 x .062 Washers of multiple thickness are used as required to obtain a thickness of .005" to .015" of allowable end-play in the drive shaft.
18	736-04306	1	/P	Washer, 1.75 x 1.5 x .005 Washers of multiple thickness are used as required to obtain a thickness of .005" to .015" of allowable end-play in the drive shaft.
18	736-04307	1	/P	Washer, 1.75 x 1.5 x .03 Washers of multiple thickness are used as required to obtain a thickness of .005" to .015" of allowable end-play in the drive shaft.
18	736-04308	1	/P	Washer, 1.75 x 1.5 x .01 Washers of multiple thickness are used as required to obtain a thickness of .005" to .015" of allowable end-play in the drive shaft.
18	736-04309	1	/P	Washer, 1.375 x 1.015 x .062 Washers of multiple thickness are used as required to obtain a thickness of .005" to .015" of allowable end-play in the drive shaft.

21A-662D066 250cc Roto-Tiller (2009)
Transmission Assembly

Page 12 of 12

Ref #	Part Number	Qty	S/P/F	Description
19	941-04298	1	/P	Cone Bearing
20	941-04299	1	/P	Cup Bearing
21	941-04300	1	/P	Bushing, 1.25 x 1 x .005 x 1.5
22	941-3037	1	/P	Ball Bearing
23	GW-1104	1	/P	Woodruff Key, .25 x 1.12
24	GW-1442	1	S	Pin, .375 x .72
25	GW-20694	1	/P	Transmission Cover Gasket
26	GW-20712	1	/P	Wheel Drive Clutch
27	GW-20718	1	S	Spur Gear
28	GW-20791	1	/P	Pinion Shaft
29	GW-20792	1	S	Pinion Gear
30	GW-20873	1	/P	Housing Cover
31	1916193001	1	/P	Transmission Cover
32	GW-20912	1		Drive Shaft
33	GW-20913	1	/P	Worm Gear
34	GW-20914	1	/P	Wheel Drive Gear
35	GW-9055	1	/P	Spring, .850 x .875
36	GW-9093	1	/P	Bowed Ring
37	GW-9301099	1	/P	Key, .188 x 1
38	GW-9373	1	/P	Hi-Pro Key, .25 x 1.312
39	GW-9428	1	/P	Bushing, 1.24 x .75 x .18
40	GW-9467	1	/P	Oil Plug
41	GW-9677	1	/P	Hex Screw, 5.16-18 x .38
42	GW-9935	1	/P	Washer, 1.46 x 1.016 x .062
43	GW-9953	1	/P	Washer, 1.022 x .75 x .059