

21A-531-081 Pony Tiller 12211
Bolo Tines, Wheels

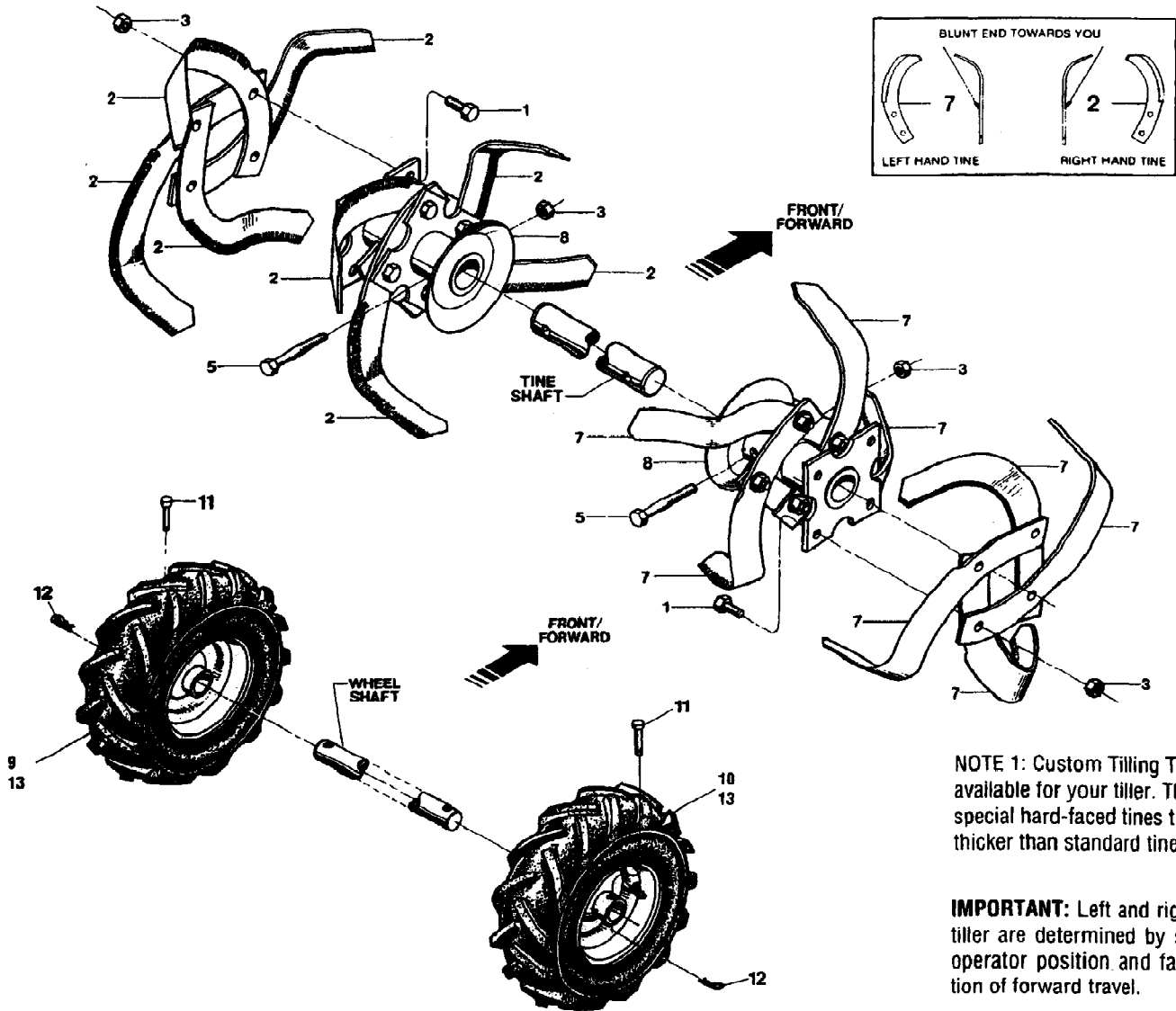

NOTE 1: Custom Tilling Tines are available for your tiller. These are special hard-faced tines that are thicker than standard tines.

IMPORTANT: Left and right sides of tiller are determined by standing in operator position and facing direction of forward travel.

21A-531-081 Pony Tiller 12211
Bolo Tines, Wheels

Page 2 of 25

Ref #	Part Number	Qty	S/P/F	Description
1	1100043	16	S	Hex Hd. Screw, 3/8-16 x 1-1/4 Specify GRADE 5 if ordering part locally.
2	1270-2A	8	S	Bolo Tine-single. Right hand tine used on left side of tiller.(Incl. two ea. Refs. 1 and 3)
3	1733398	18	S	Hex Locknut, 3/8-16
5	1982612	2	S	Hex Hd. Screw, 3/8-16 x 2, Grade 8
7	1270-1A	8	S	Bolo Tine-single. Left hand tine used on right side of tiller.(Incl. two ea. Refs. 1 and 3)
8	1902154010	2	S	Tine Holder. For left and right sides
	1901118	1	S	Bolo Tine Replacement Set (Incl. eight ea. right hand and left hand tines, and sixteen ea. Refs. 1 and 3)
	2475-1	8	S	Custom Tilling Bolo Tine, Left hand tine Custom Tilling tines are available for your tiller. These are special hard-faced tines that are thicker than standard tines.
	2475-2	8	S	Custom Tilling Bolo Tine, Right hand tine Custom Tilling tines are available for your tiller. These are special hard-faced tines that are thicker than standard tines.
	10802	1	S	Custom Tilling Bolo Tine Replacement Set (Incl. eight ea. right hand and left hand custom tines, and sixteen each of Refs. 1 and 3)
9	2706-01	1	S	Wheel and Tire Assy., left side, 4.10 x 6 tire on 6" wheel For Model 12211 - S/N 122111100101-122111199999
10	2706-02	1	S	Wheel & Tire Assy., right side, 4.10 x 6 tire on 6" wheel For Model 12211 - S/N 122111100101-122111199999
11	9380	2	S	Clevis Pin, .312 x 1-3/4
12	9338	2	S	Hitch Pin
13	1917487	2	S	Wheel and Tire Assembly For Model 12211 - S/N 122111200101-122111299999

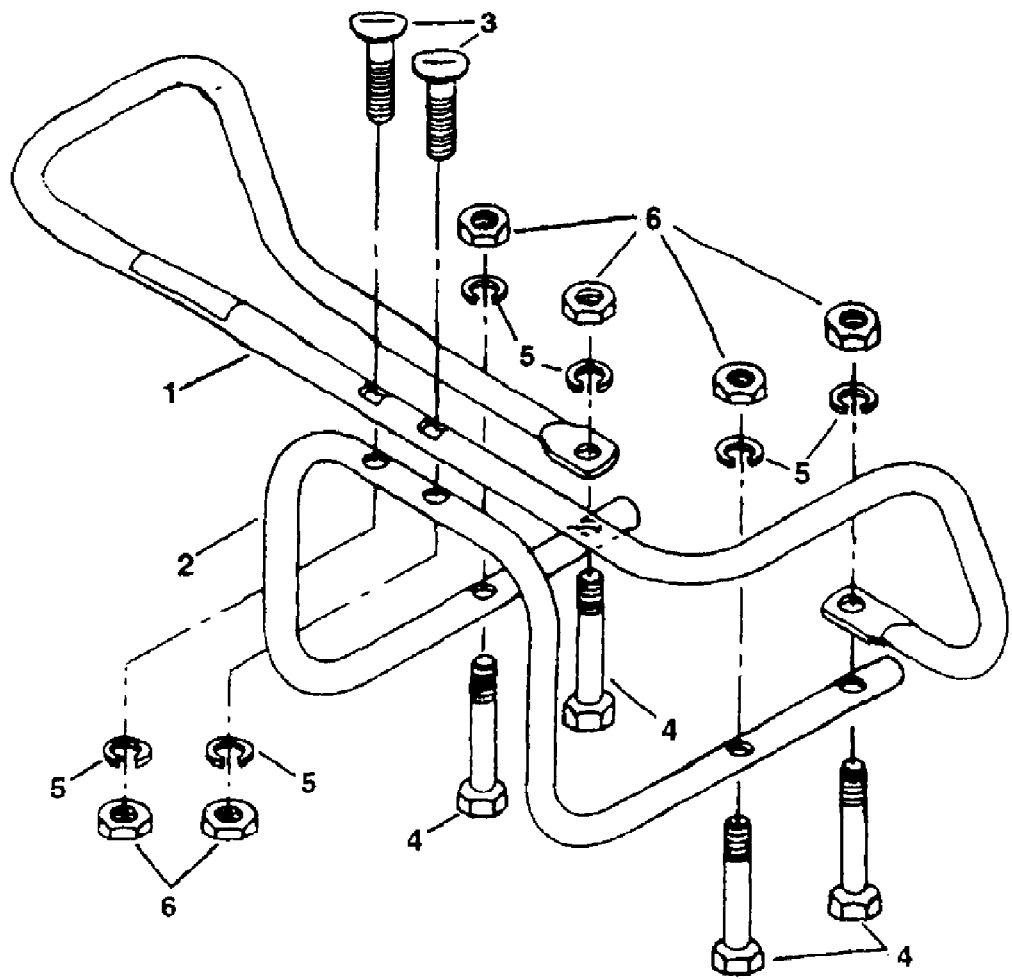

BUMPER ATTACHMENT – PART #12593 (Viewed from front of tiller.)

21A-531-081 Pony Tiller 12211
Bumper Attachment

Page 4 of 25

Ref #	Part Number	Qty	S/P/F	Description
1	1904757001	1	S	Bumper, Top Section 1
2	1904758001	1	S	Bumper, Bottom Section 1
3	1731025	2	/P	Curved Hd. Screw, 5/16-18 x 2 (Special); also see #1915811 Hardware Kit
4	1111608	4	F	Hex Hd. Screw, 5/16-18 x 2-1/2, (Not avail. separately - order #1915811 Hardware Kit); Specify Grade 5 if ordering part locally.
5	1100242	6	S/F	Lockwasher, 5/16, (Not avail. separately - order #1915811 Hardware Kit)
6	1186230	6	S/F	Hex Nut, 5/16-18 (Not avail. separately - order #1915811 Hardware Kit)
	1915811	1	/P	Hardware Kit. Includes: two Ref. 21; four Ref. 22; six Ref. 23 and six Ref. 24

DRIVE SHAFT, INPUT PINION SHAFT and GEAR ASSEMBLIES

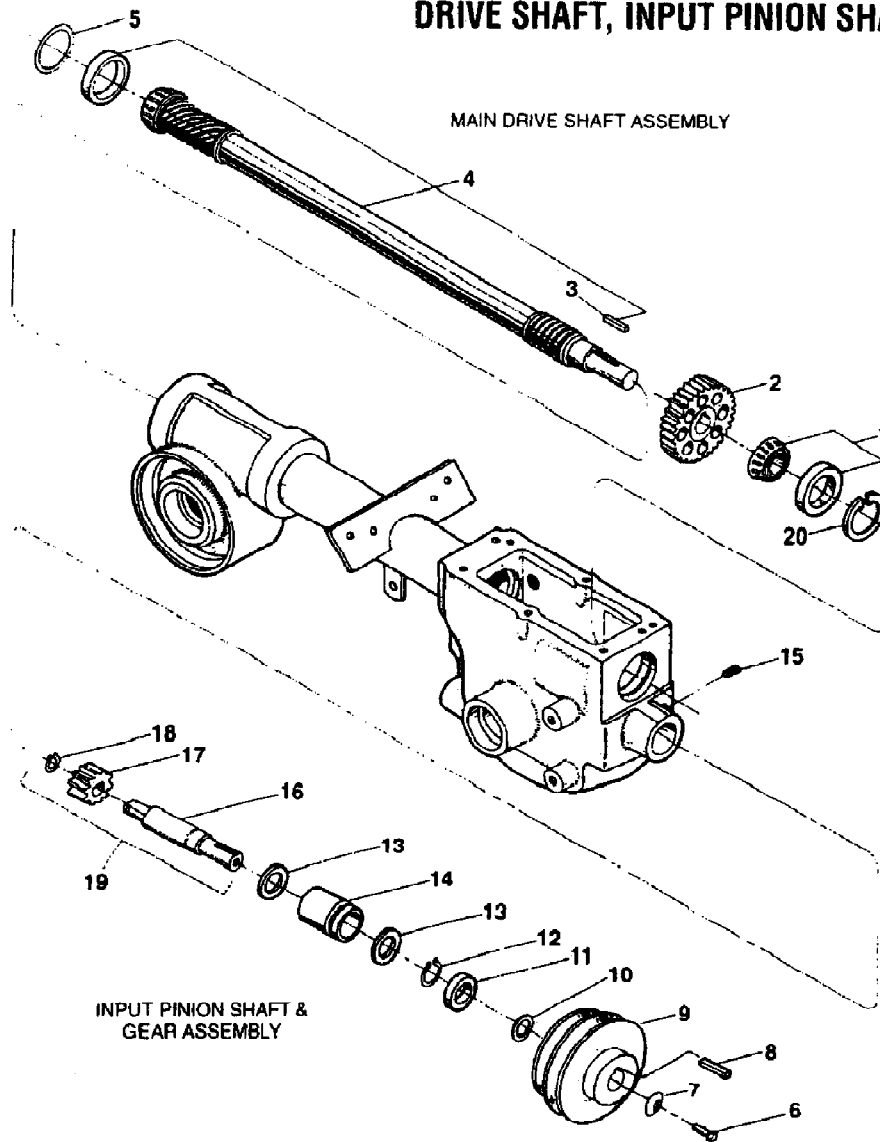

Ref #	Part Number	Qty	S/P/F	Description
1	1714	1	S	Bearing, Tapered Roller with Race
2	20718	1	S	Spur Gear
3	9301	1	S	Key, 3/16 sq. x 1
4	GW-11603	1		Main Drive Shaft (Drive shaft is one- piece with integral, single-lead, work-hardened front worm, and integral, six-lead, work-hardened rear worm. Also includes pressed on #1714 bearing and #9301 key)
5	1224-1	A/R	S	Shim, Rear Bearing Cap, .010" thick As Required; (Shim between drive shaft rear bearing and rear bearing cap to achieve 5-to-10 thousandths of an inch (.005-.010 end play on drive shaft.)
5	1224-2	A/R	S	Shim, same as above, but .030" thick As Required; (Shim between drive shaft rear bearing and rear bearing cap to achieve 5-to-10 thousandths of an inch (.005-.010 end play on drive shaft.)
5	1224-3	A/R	S	Shim, same as above, but .005" thick As Required; (Shim between drive shaft rear bearing and rear bearing cap to achieve 5-to-10 thousandths of an inch (.005-.010 end play on drive shaft.)
	1325C	A/R	S	Shim Set As Required; (Incl. two #1224-1; two 1224-2 and one #1224-3)
6	9572	1	S	Hex Hd. Screw, 5/16-24 x 1-1/8 Specify GRADE 5 if ordering part locally.
7	9944	1	S	Washer, Disc Spring (concave surface faces pulley)
8	1108841	1	S	Key, 3/16 sq. x 1-1/2
9	20880	1		Transmission Drive Pulley
10	1440	1	S	Support Washer
11	85030	1		Oil Seal, Input Pinion Shaft
12	9500	1	S	Retaining Ring (external)
13	9953	2	S	Thrust Washer
14	9428	1	S	Bushing
15	9677	1	S	Set Screw, 5/16-18 x 3/8 Specify GRADE 5 if ordering part locally.
16	20791	1	S	Input Pinion (steel shaft)
17	20792	1	S	Input Pinion Gear
18	9093	1	S	Retaining Ring (external)
19	20799	A/R	S	Pinion Assy. As Required; (Incl. one each Refs. 16, 17 and 18)
20	9517	1	S	Retaining Ring (internal)

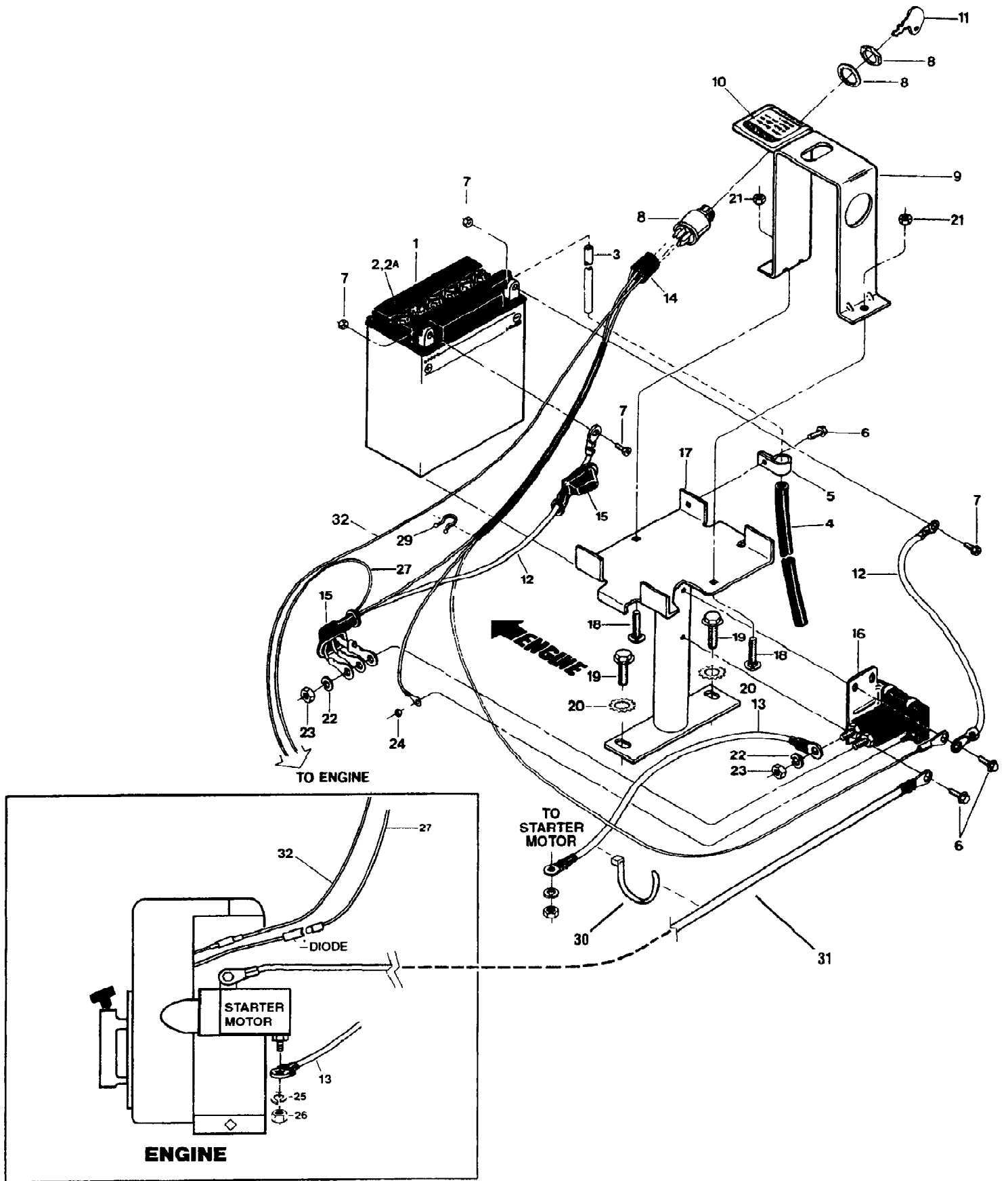

Ref #	Part Number	Qty	S/P/F	Description
1	GW-96512	1	S	Battery, 12 Volt, 9 Amp (Incl. Ref. 7)
2	9462	A/R		Battery Cap (yellow) As required
2A	9248	A/R		Battery Cap (white) As required
3	9009	1	S	Vent Tube
4	1475	1		Shield, Vent Tube (hard plastic)
5	9224	1		Clamp
6	9552	3	S	Hex Flange Screw, Self-Threading, 1/4-20 x 1/2" Specify Grade 5 if ordering part locally.
7	11361	1		Battery Hardware Kit - Includes two M6 x 11 mm Bolts and two M6 Nuts (metric sizes)
8	1908112	1	S	Ignition Switch (Incl. two ignition keys [Ref. 11], one lockwasher and one nut (lockwasher and nut not available separately)
9	1904570	1		Battery Hold-Down Clamp/Switch Mounting Plate Assy. (Incl. Ref.10)
10	1904548	1	S	Decal, Ignition Switch
11	96520	1	S	Ignition Key (pair)
12	96509	2		Battery Cable
13	96510	1	S	Cable (solenoid to starter motor)
14	1908118	1	S	Wire Harness Assy. (Available as complete assembly only); Incl. wire assy. w/connector to large solenoid stud (red wire); wire assy. w/connector to small solenoid stud (red wire); wire assy. w/connector to solenoid grounding screw (red wire); wire assy w/connector to engine ground shut-off (green wire); plastic protector tube; wire terminal
15	97020	2	S	Boot, Insulating
16	96514	1	S	Solenoid (Incl. nuts and washers for cables and wires) 1
17	20837	1	S	Battery Bracket
18	1186023	2		Round Hd. Screw, Square Neck, 1/4-20 x 1-1/4
19	1186331	2	S	Hex Flange Screw, 5/16-18 x 1" Specify Grade 5 if ordering part locally.
20	1177548	2	S	Lockwasher, External Tooth 2
21	1186389	2	/P	Hex Locknut, 1/4-20 2
22	1100242	2	S	Lockwasher, 5/16 2
23	1186211	2	/P	Hex Nut, 5/16-24 2
24	9853	1	S	Hex Locknut, #10-32
25		1		Lockwasher, #10 (Not available from factory)
26		1		Hex Nut, #10-24 (Not available from factory)
27	1901894	1	/P	Recharge Wire Assembly
?28	9218	1	S	Clip (holds recharging line)
29	9265	1	S	Plastic Wire Tie
30	9202	1	S	Plastic Wire Tie
31	1901202	1	/P	Cable (ground wire to starter motor bracket)
32	1917262	1	/P	Ground Wire Assy. (shut off)

21A-531-081 Pony Tiller 12211
Engine, Support Brackets, Pulleys, Belts, Belt Cover

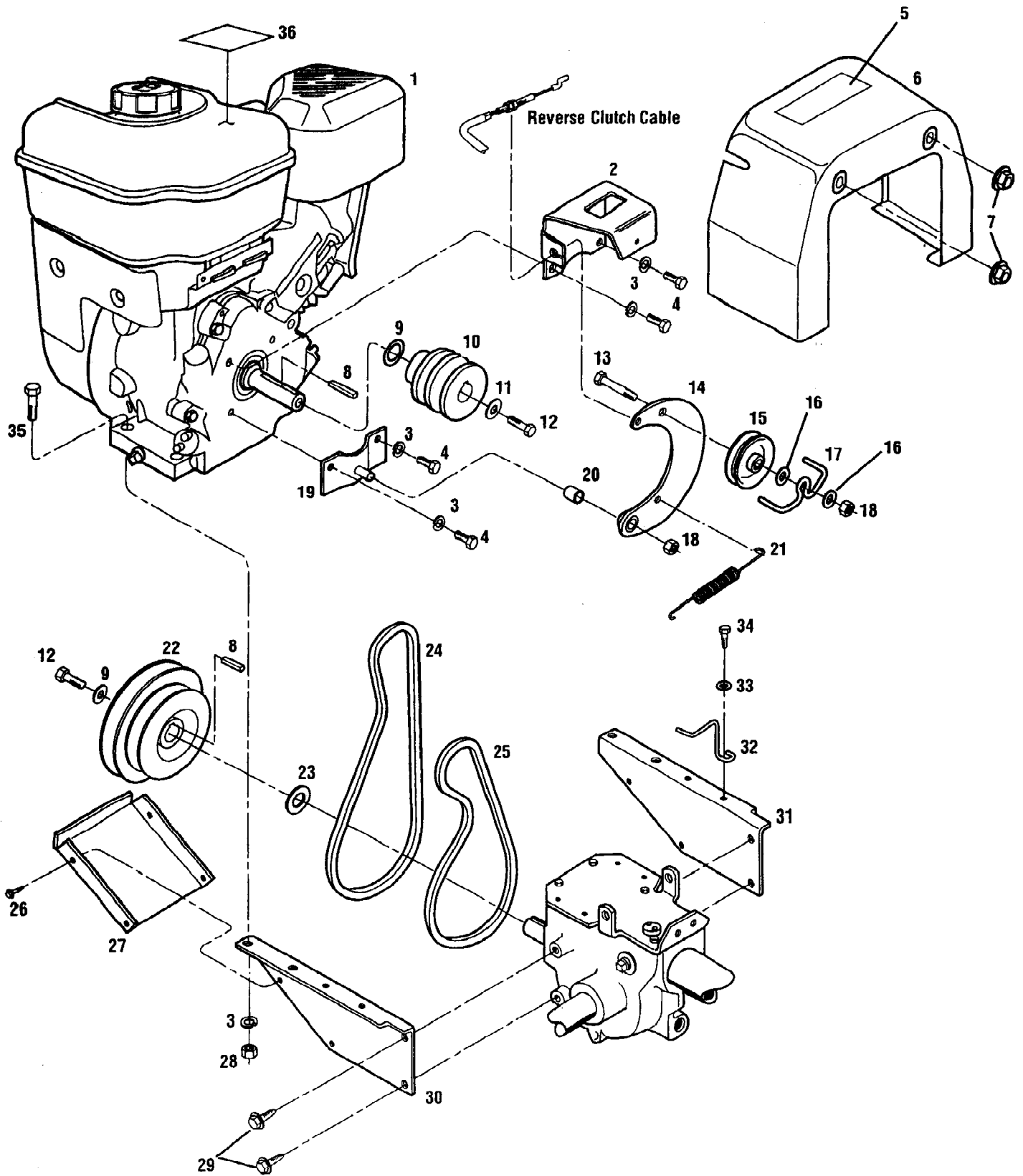

Ref #	Part Number	Qty	S/P/F	Description
1		1		Engine - 7HP, standard recoil start See your local authorized engine service dealer for engine parts or service. refer to engine nameplate for engine type and code information.
2	1917326001	1	S	Bracket, Clutch Cable
3	1100242	8	S	Lockwasher-5/16
4	1111696	4		Hex Hd. Screw, 5/16-24 x 1/2
5	1904557	1		Decal, Hot Surfaces/Belt Warning
6	1917139	1	S	Cover (Incl. Ref. 5)
7	1186391	2	S	Flange Lock Nut, 5/16-18
8	1108841	2	S	Key, 3/16 x 1-1/2
9	1138-1	1	S	Shim
10	1916520	1	S	Pulley, Engine Drive
11	9944	2	S	Belleville Washer
12	9572	2	S	Hex Hd. Screw, 5/16-24 x 1-1/8
13	1111606	1		Hex Hd. Screw, 5/16-18 x 2
14	1916578001	1		Reverse Idler Arm
15	1916535	1	/P	Pulley, Reverse Idler
16	1107382	2	/P	Flat Washer, 5/16
17	1916725	1	S	Belt Guide
18	1110107	1	S	Locknut, 5/16-18
19	1916559001	1		Bracket, Reverse Idler
20	1916536	1		Bushing
21	1916728	1	S	Spring, Reverse Return
22	1916522	1	S	Transmission Pulley
23	1440	1	S	Support Washer
24	1916753	1	S	Reverse Drive Belt
25	1909404	1	/P	Forward Drive Belt
26	1900396	4	/P	Hex Hd. Screw, #10-32 x 1/2, self-tapping
27	1916189001	1	S	Guard, Belts/Pulleys
28	1186230	4	S	Hex Nut, 5/16-18
29	1186329	4	S	Hex Flange Screw, 5/16-18 x 3/4 Specify GRADE 5 if ordering part locally.
30	1916797001	1	/P	Engine Support Bracket, left side
31	1916796001	1	S	Engine Support Bracket, right side
32	1916736	1	S	Belt Guide
33	1107381	1	S	Flat Washer, 1/4
34	9573	1	S	Hex Hd. Screw, self-tapping, 1/4-20 x 3/4 Specify GRADE 5 if ordering part locally.
35	1100799	4	S	Hex Hd. Screw, 5/16-18 x 1-1/2
36	1915810	1		Decal, Stabilization

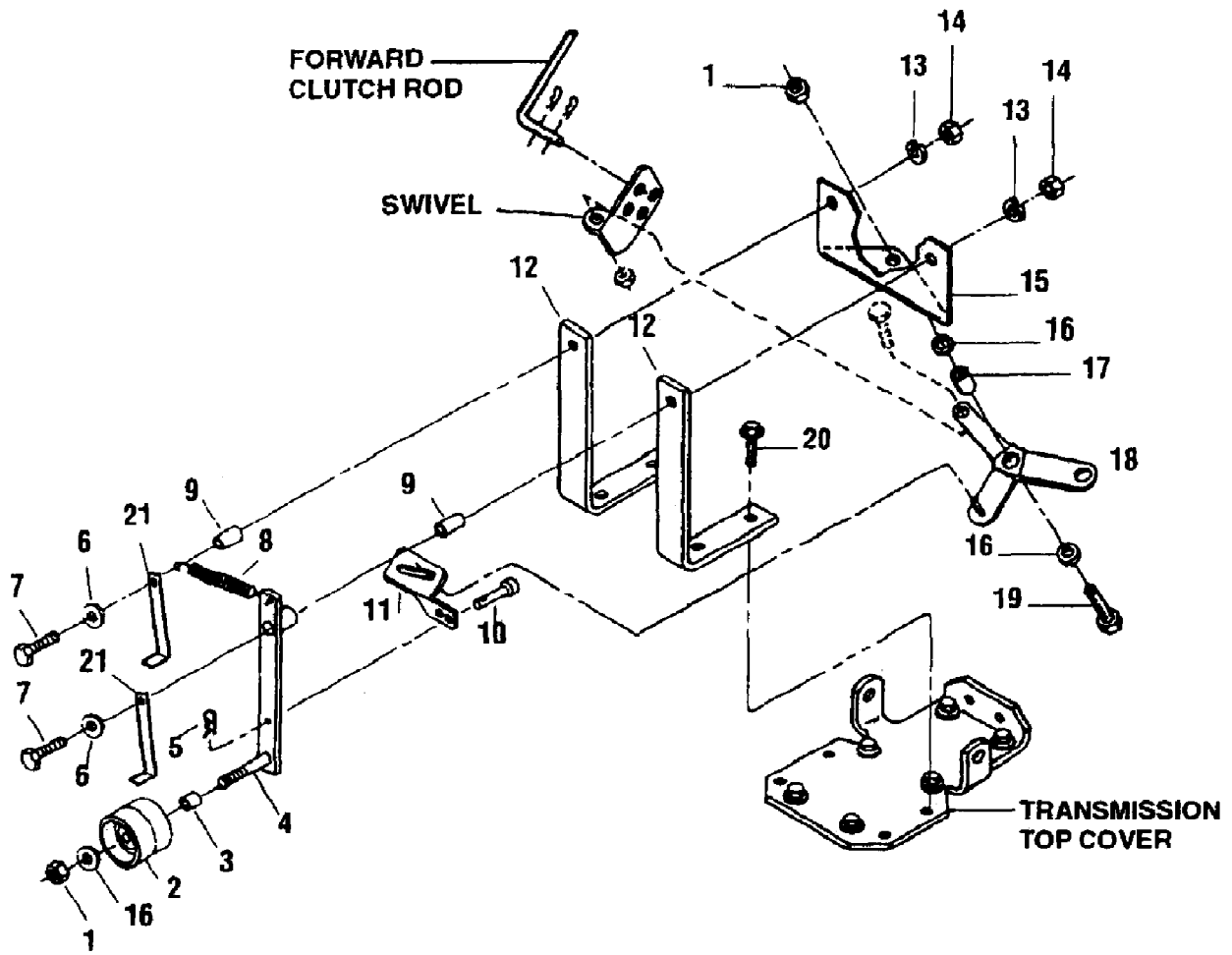

21A-531-081 Pony Tiller 12211
Forward Idler Assembly

Page 12 of 25

Ref #	Part Number	Qty	S/P/F	Description
1	1110108	2	S	Hex LOCKnut, 3/8-16
2	9090	1	S	Idler Pulley, Forward
3	20532	1	S	Spacer
4	1916192001	1	/P	Left Idler Arm, forward tiller direction
5	9338	1	S	Hairpin Cotter
6	20545	1	S	Plain Washer. 5/16
7	1111607	2	S	Hex Hd. Screw, 5/16-18 x 2-1/4 Specify GRADE 5 if ordering part locally.
8	1916727	1	/P	Spring
9	9479	2	S	Pivot Bushing
10	9340	1		Pin
11	20517-01	1		Forward Link
12	1916194001	2		Mounting Bar
13	1100242	2	S	Lockwasher, 5/16
14	1186230	2	S	Hex Nut, 5/16-18
15	1916195001	1		Shifting Base
16	20553	3	S	Spacer (Bushing)
17	20532	1	S	Bushing (Bellcrank)
18	1916196001	1	/P	Bellcrank
19	1100043	1	S	Hex Hd. Screw, 3/8-16 x 1-1/4 Specify GRADE 5 if ordering part locally.
20	1186331	1	S	Hex Flange Screw, 5/16-18 x 1
21	1917149001	2	/P	Belt Guide, Forward Belt

21A-531-081 Pony Tiller 12211
Handlebar Assembly And Control Levers

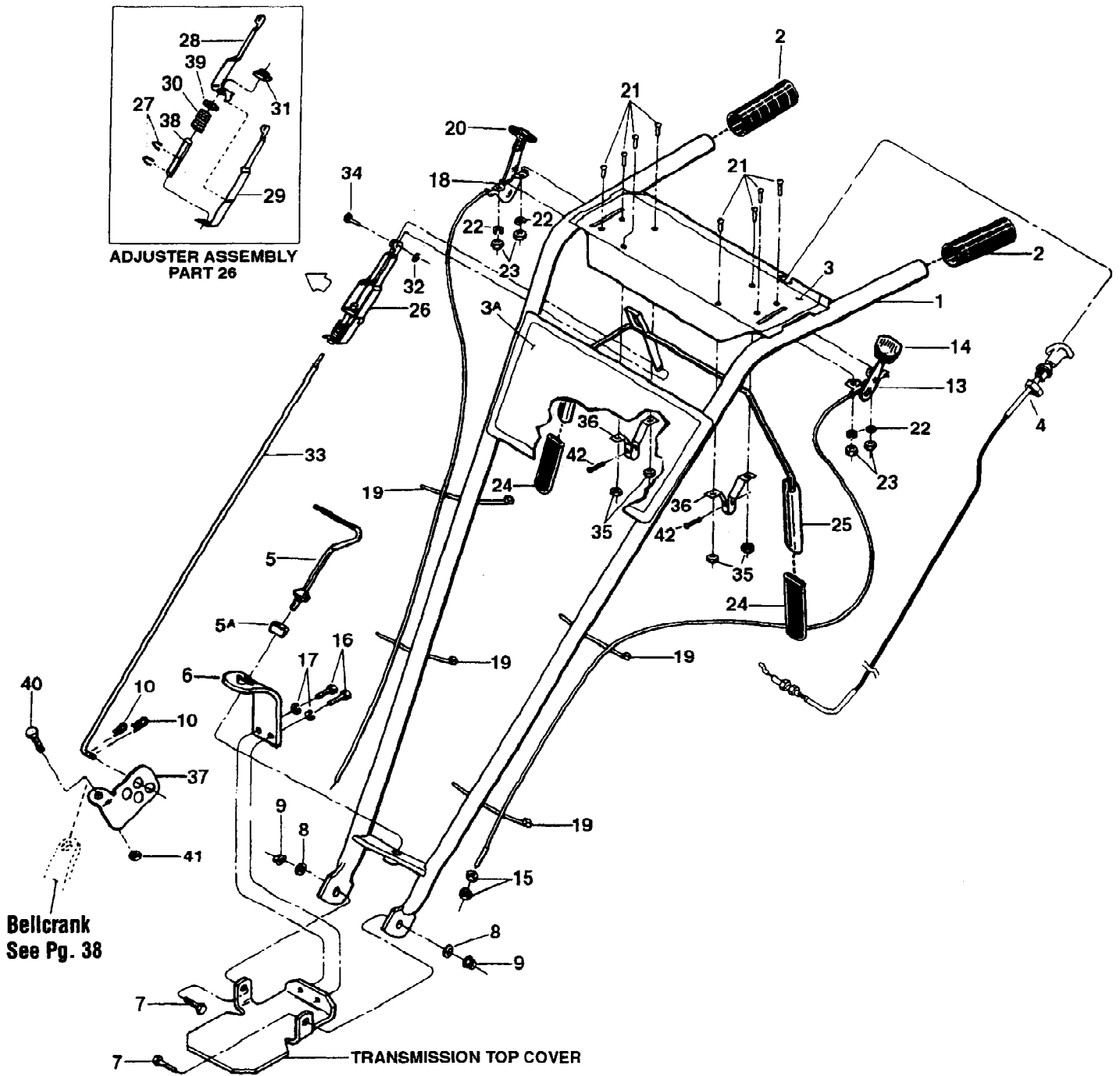

21A-531-081 Pony Tiller 12211
Handlebar Assembly And Control Levers

Page 14 of 25

Ref #	Part Number	Qty	S/P/F	Description
1	1917606	1		Handlebars (Incl. Refs. 2, 3 & 3A) For Model 12211 (Recoil Start Engine)
2	9126	2	S	Grip
3	1917537	1	/P	Decal, Control Panel For Model 12211 (Recoil Start Engine)
3A	20924	1	S	Decal, Model Name/Logo
4	1916784	1	S	Reverse Clutch Control Cable
5	20703	1		Height Adjustment Handle
5A	9955	1	S	Washer, Keyed
6	1900475001	1	S	Bracket, Handlebar Height Adjustment
7	1100046	2	S	Hex Hd. Screw, 3/8-16 x 1 Specify GRADE 5 if ordering locally.
8	9904	2	S	Washer, Plain (flat) 3/8, S.A.E.
9	9837	2	S	Hex Locknut, 3/8-16
10	9338	2	S	Hair Pin Cotter
13	9442	1	S	Wheel Gear Control and Cable Assy. (Incl. Refs. 14, 15, 19, 21, 22 & 23)
14	9057	1	S	Knob, Wheel Gear Control Lever
15	1186211	2	/P	Hex Nut, 5/16-24
16	1100068	2	S	Hex Hd. Screw, 3/8-16 x 3/4 Specify GRADE 5 if ordering locally.
17	1100243	2	S	Lockwasher, 3/8
18	1916900	2		Engine Throttle Control and Cable
19	1735531	4	S	Cable Ties, Plastic
20	9212	1	S	Knob, Throttle Control Lever
21	1114748	8	/P	Round Hd. Screw, #10-32 x 1/2
22	1100240	4	/P	Lockwasher, #10
23	1186208	4	/P	Hex Nut, #10-32
24	9390	2	S	Grip
25	20863	1	S	Bail, Forward Clutch Control (Incl. two Ref. 24)
26	20862	1	S	Adjuster Assy. (Incl. Refs. 27, 28, 29, 30, 38 and 39)
27	9532	2	S	Klip Ring
28	20808	1	S	Adjuster, Right Side
29	20809	1	S	Adjuster, Left Side
30	9059	1	S	Spring, Adjuster
31	9522	1		Rectangular Nut
32	9386	1		Klip Ring
33	20831	1	S	Rod, Forward Clutch
34	97083	1		Clevis Pin
35	9853	4	S	Sems Nut
36	20806	2	S	Bracket, Bail Support
37	20888	1	S	Swivel
38	9432	1		Bushing
39	9973	1		Washer
40	1100805	1	S	Hex Hd. Screw, 1/4-20 x 3/4 Specify GRADE 5 if ordering locally.
41	9811	1		Nut, 1/4-20

21A-531-081 Pony Tiller 12211
Handlebar Assembly And Control Levers

Page 15 of 25

Ref #	Part Number	Qty	S/P/F	Description
42	9552	2	S	Hex Flange Screw, self-tapping, 1/4-20 x 1/2 Specify GRADE 5 if ordering locally.

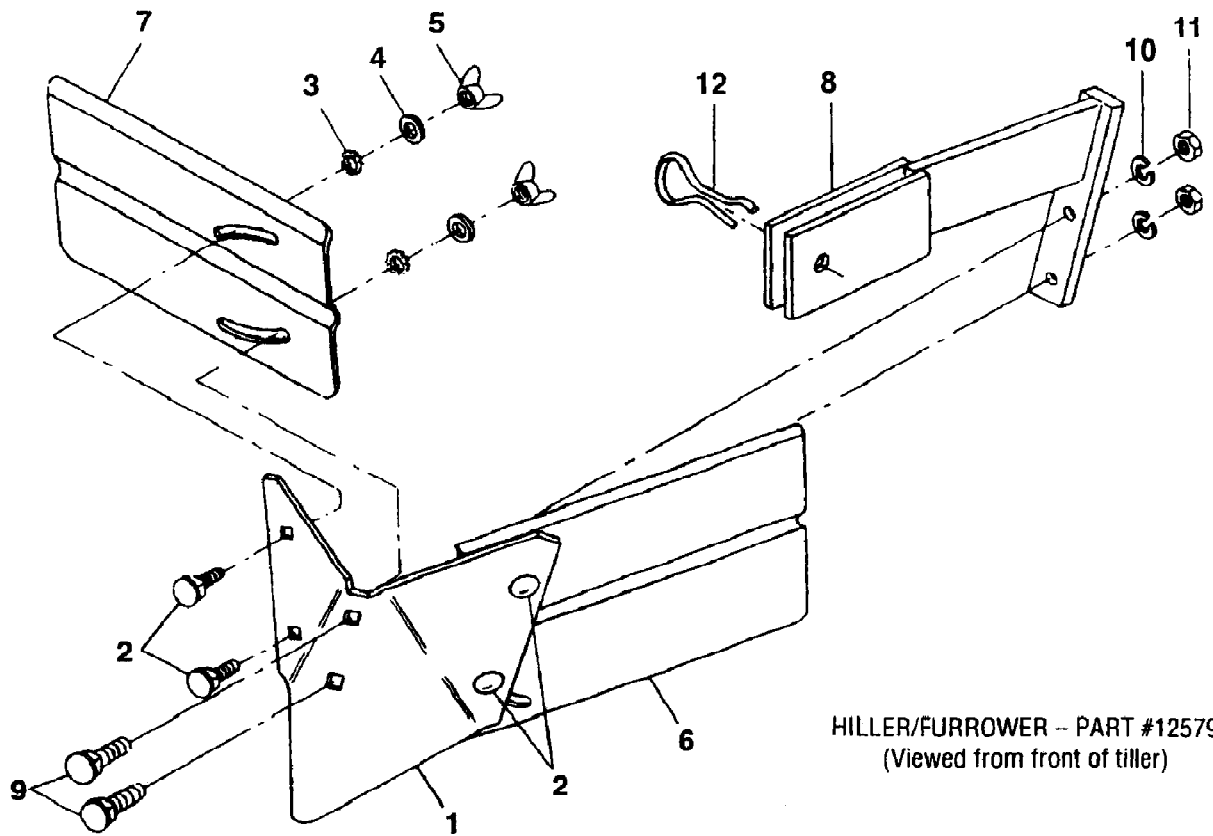

HILLER/FURROWER - PART #12579
(Viewed from front of tiller)

21A-531-081 Pony Tiller 12211
Hiller/Furrower Attachment

Page 17 of 25

Ref #	Part Number	Qty	S/P/F	Description
1	1900771001	1	/P	Furrower Blade
2	1186098	4	/P	Carriage Bolt, 5/16-18 x 3/4
3	1177548	4	S	Star Washer, External Tooth, 5/16
4	9902	4		Plain Washer, 5/16 S.A.E
5	9824	4	S	Wing Nut, 5/16-18
6	1900773001	1	/P	Hiller Wing, left
7	1900774001	1	/P	Hiller Wing, right
8	1900772001	1	S	Blade Mounting Bracket
9	9725	2	S	Carriage Bolt, 3/8-16 x 1-1/2
10	1100243	2	S	Lockwasher, 3/8, plated
11	1186231	2	S	Hex Nut, 3/8-16, plated
12	9318	1	S	Clinch Pin
	~N/A	1		Complete Hiller/Furrower Attachment (Incl. blade, bracket, hiller wings and mounting hardware)
	12579	1		Hiller/Furrower

21A-531-081 Pony Tiller 12211
Hood, Bracket And Depth Regulator

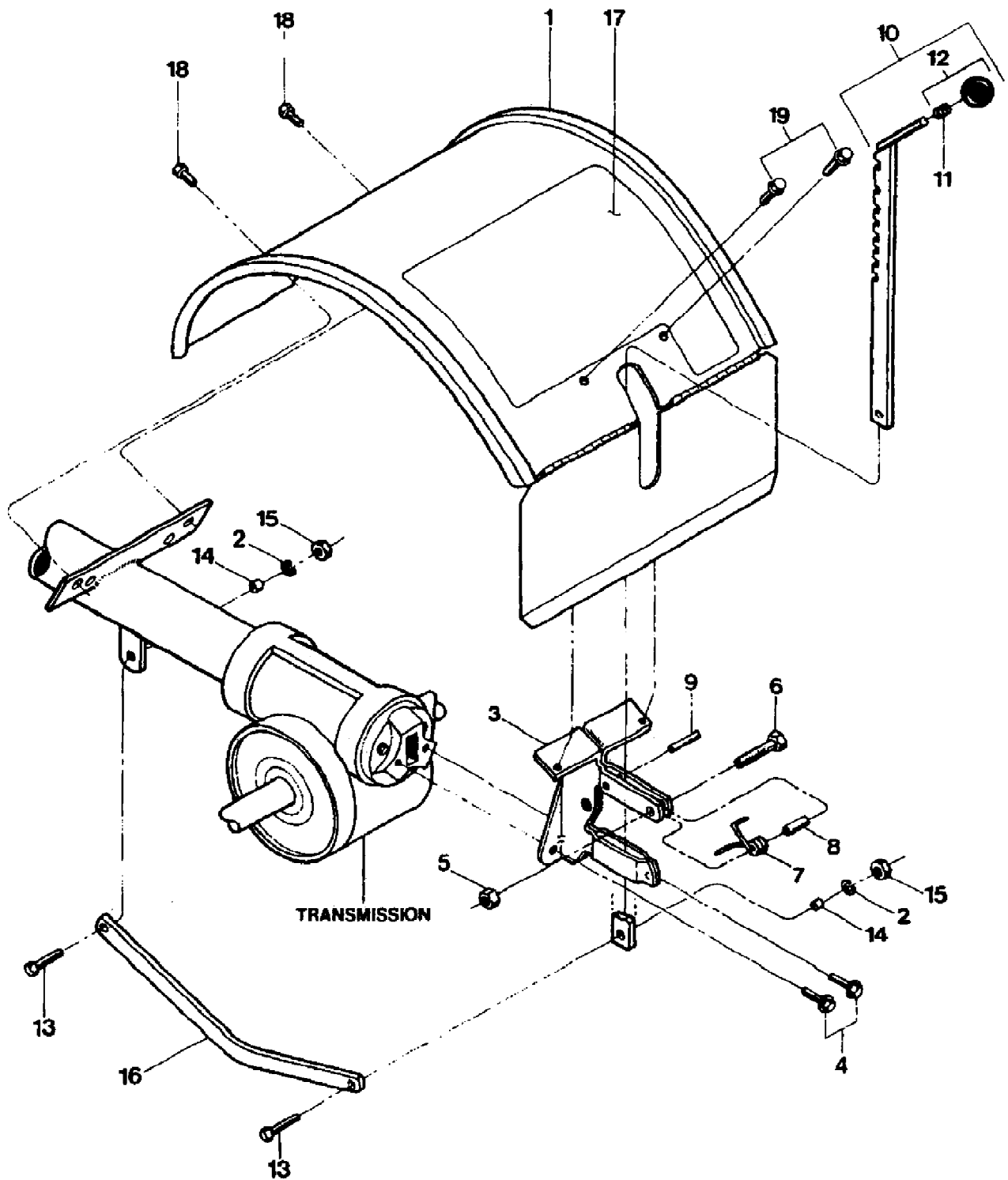

21A-531-081 Pony Tiller 12211
Hood, Bracket And Depth Regulator

Page 19 of 25

Ref #	Part Number	Qty	S/P/F	Description
1	1917605	1	/P	Tine Hood (Incl. hood flap and Ref.17)
2	1100243	2	S	Lockwasher, 3/8
3	2527	1	S	Bracket-hood & depth regulator (Incl. Ref. No. 9)
4	90038	2		Hex Flange Screw, 5/16-18 x 5/8 Specify GRADE 5 if ordering part locally.
5	9811	1		Hex Locknut, 1/4-20
6	1100069	1	S	Hex Hd. Screw, 1/4-20 x 1 Specify GRADE 5 if ordering part locally.
7	9384	1	S	Spring
8	9438	1		Spacer
9	9308	1	S	Roll Pin (spiral), 1/4 x 1
10	1117A	1	S	Depth Adjustment Bar Assembly (Incl. Refs. 11 and 12)
11	9120	1	S	Retaining Ring (tolerance ring)
12	9119	1	S	Knob, Depth Regulator (Incl. Ref. 11)
13	1100043	2	S	Hex Hd. Screw, 3/8-16 x 1-1/4 Specify GRADE 5 if ordering part locally.
14	1113-1	2	S	Bushing, Drag Bar
15	1186231	2	S	Hex Nut, 3/8-16
16	20775	1	S	Drag Bar
17	1917536	1	/P	Decal, operating instructions
18	9553	2	S	Hex Hd. Screw, self-tapping, 5/16-18 x 1/2 Specify GRADE 5 if ordering part locally
19	9552	2	S	Hex Flange Screw, self-tapping, 1 /4-20 x 1/2 Specify GRADE 5 if ordering part locally

21A-531-081 Pony Tiller 12211
Row Marker Attachment

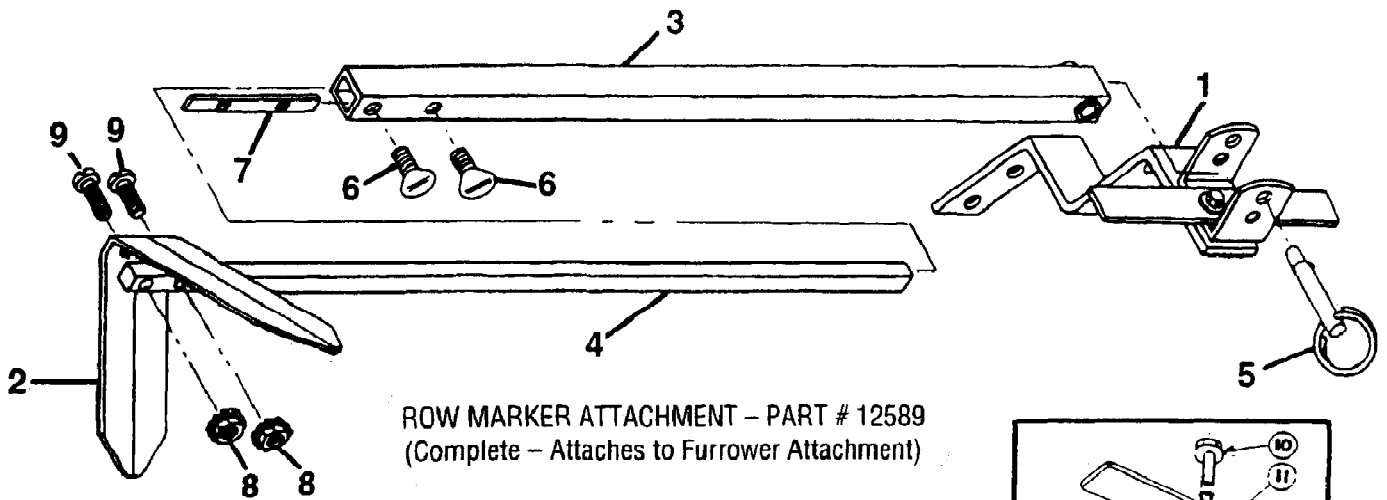

ROW MARKER ATTACHMENT - PART # 12589
(Complete - Attaches to Furrower Attachment)

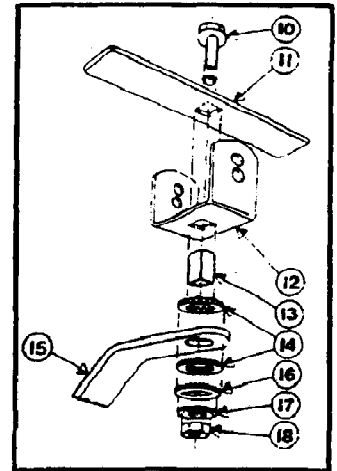
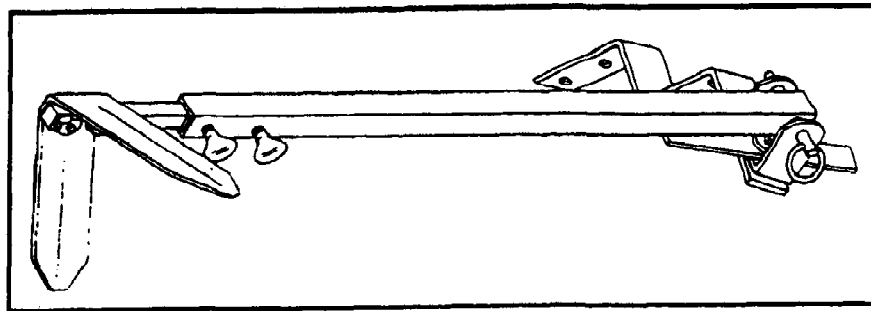

MAIN SUPPORT/YOKE ASSEMBLY
PART # 1904522001

21A-531-081 Pony Tiller 12211
Row Marker Attachment

Page 21 of 25

Ref #	Part Number	Qty	S/P/F	Description
1	1904522001	1		Complete Main Support & Yoke Assy.
2	1594	1	S	Marker Blade
3	1904524001	1		Marker Arm
4	1904523001	1		Marker Extension Arm
5	9347	1	S	Hitch Pin
6	9786	2	F	Thumbscrew, 1/4-20 x 1/2 (Not avail. separately - see #1837 Hardware Package)
7	1596	1	S	Nut Bar
8	9828	2	F	Hex Nut, #10-24 w/attached start washers (Not avail. separately - see #1837 Hardware Package)
9	1100135	2	/P/F	Round Hd. Screw, #10-24 x 1 (Not avail. separately - see #1837 Hardware Package)
	1837	1	S	Hardware Package.
	12582	1		Row Marker Attachment & Pony Hiller/Furrower Attachment - Complete.
	12589	1		Row Marker Attachment - Complete. Attaches to #12579 Furrower Attachment.
10	1186349	1	/P	Hex Flange Screw, 3/8-16 x 1-1/2' Specify Grade 5 if ordering part locally.
11	1593	1	S	Stop Bar
12	1592	1	S	Yoke
13	1591	1	S	Tube Key (square)
14	1590	2	S	Friction Washer
15	1588	1	S	Main Support
16	1589	1	S	Washer (square hole)
17	9925	1		Disc Spring Washer
18	1186231	1	S	Hex Nut, 3/8-16

Transmission Housing, Covers, Seals, Gaskets, Plugs

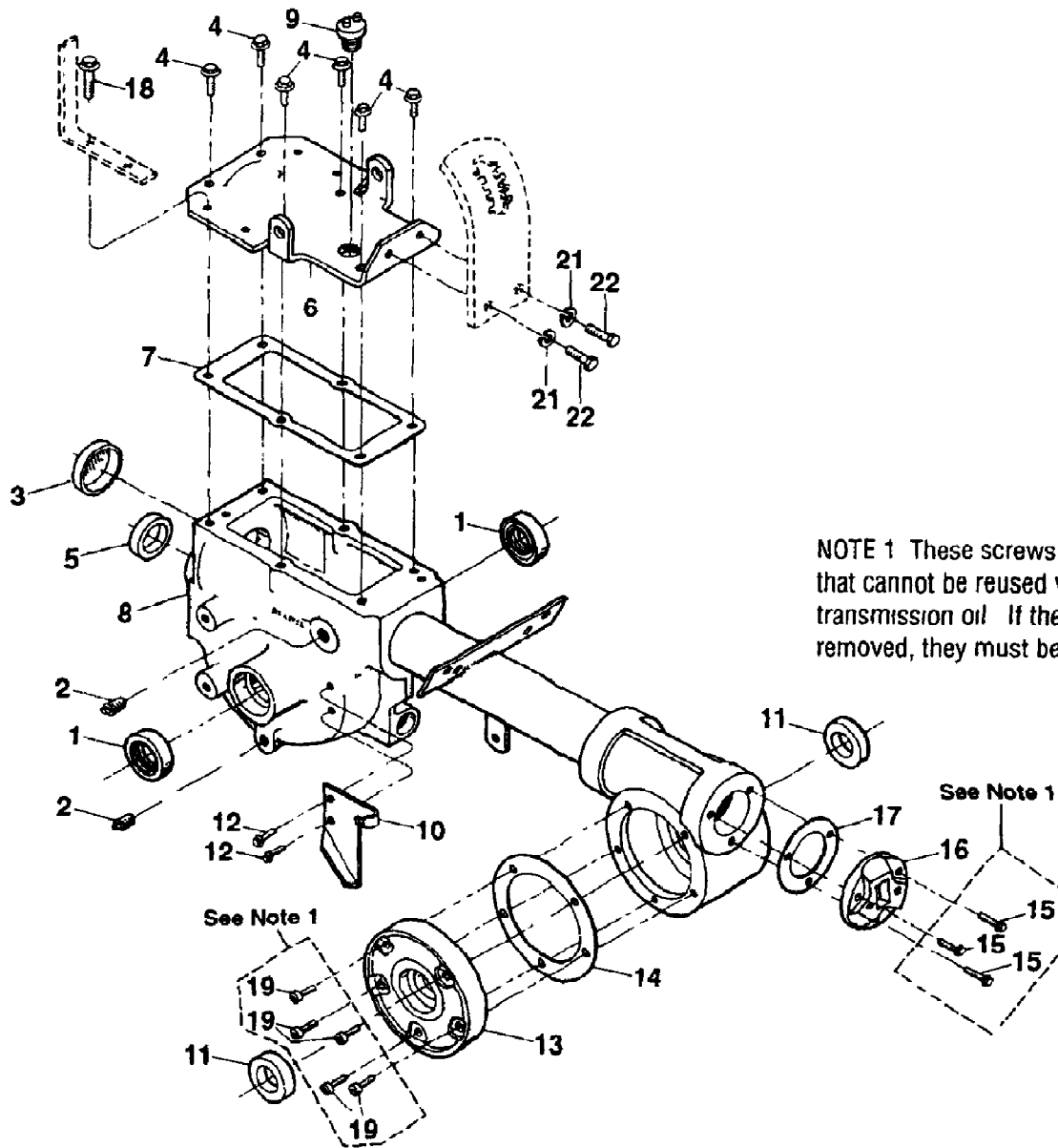

Transmission Housing, Covers, Seals, Gaskets, Plugs

Ref #	Part Number	Qty	S/P/F	Description
1	9621	2	S	Oil Seal (Double Lip), Wheel Shaft
2	9726	2	S	Pipe Plug, 1/4,
3	97076	1	S	Seal, Transmission Bore
4	1186329	6	S	Hex Flange Screw, 5/16-18 x 3/4 Specify GRADE 5 if ordering part locally
5	85030	1		Oil Seal, Input Pinion Shaft
6	11513	1		Transmission Cover (Incl. four Ref. 18 and two ea. Refs. 21 & 22)
7	20694	1	S	Gasket, Transmission Top Cover
8	1916197001	1	S	Transmission Case Assy. (Incl. Tube and Rear Housing)
9	9467	1	S	Plug
10	1916198001	1	/P	Mounting Plate, Wheel Drive Cable
11	97073	2	S	Oil Seal, Tiller Shaft
12	90038	2		Hex Flange Screw, 5/16-18 x 5/8 Specify GRADE 5 if ordering part locally
13	1916273001	1	S	Tiller Housing Cover, left side
14	1129-1	A/R	S	Gasket, Tiller Housing Cover, .010" (Fits all covers); As Required
15	1915089	A/R	/P	Screw Kit Incl. three 1/4-20 x 7/8 Self-Sealing Screws; As Required
16	1115	1		Rear Bearing Cap
17	1124-2	A/R	S	Gasket, Rear Bearing Cap, .010" Thick As Required
18	1186331	4	S	Hex Flange Screw, 5/16-18 x 1 Specify GRADE 5 if ordering part locally
19	1915087	A/R	/P	Screw Kit Incl. five 1/4-20 x 5/8 Self-Sealing Screws; As Required
21	1100243	2	S	Lockwasher, 3/8
22	1100068	2	S	Hex Hd. Screw, 3/8-16 x 3/4 Specify GRADE 5 if ordering part locally

21A-531-081 Pony Tiller 12211

Page 24 of 25

Wheel Shaft, Eccentric Shaft And Tiller Shaft Assemblies

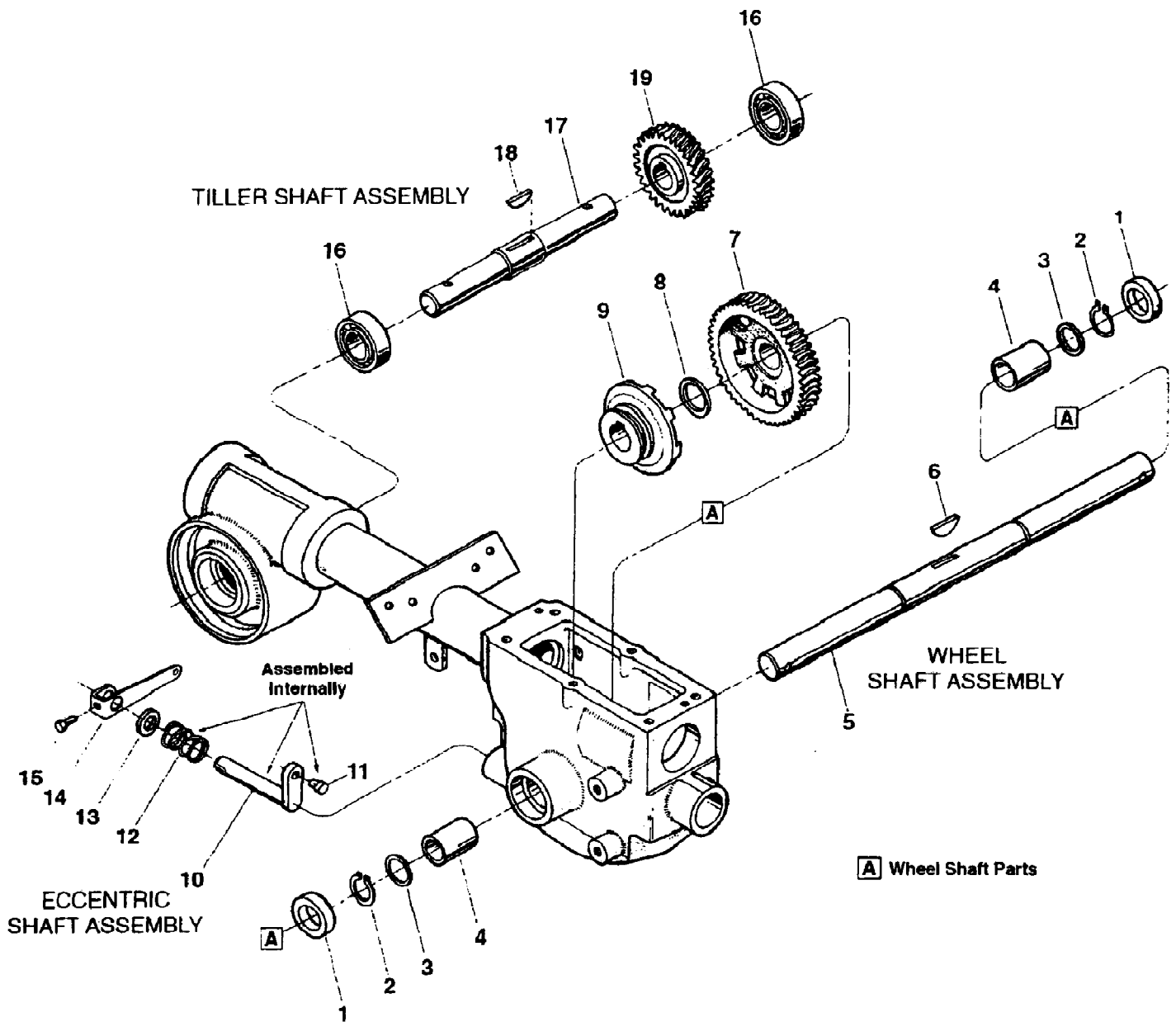

Wheel Shaft, Eccentric Shaft And Tiller Shaft Assemblies

Ref #	Part Number	Qty	S/P/F	Description
1	9621	2	S	Oil Seal
2	9511	2	S	Retaining Ring (heavy-duty, external)
3	1166-1	A/R	S	Shim, 1-1/64 I.D., .062" thick As Required
	1166-2	A/R	S	Shim, as above, but .030" thick As Required
	1166-3	A/R	S	Shim, as above, but .015" thick As Required
	1166-4	A/R	S	Shim, as above, but .010" thick As Required
4	1086	2	S	Bushing
5	2494	1	S	Wheel Shaft (Incl. Ref. 6)
6	9373	1	S	Hi-Pro Key, 1/4 x 1-5/16
7	20914	1	S	Wheel Drive Worm Gear (cast-iron)
8	9935	1	S	Shim (between key and gear), 1.016 I.D. x 1.468 O.D. x .062 Thick
9	20712	1	S	Wheel Drive Clutch (cast-iron)
10	20879	1	S	Eccentric Shaft
11	1442	1	S	Pin, Eccentric Shaft
12	9055	1	S	Spring
13	9622	1	S	Oil Seal
14	20757	1		Eccentric Shaft Lever
15	1100804	1	S	Hex Hd. Screw, 1/4-20 x 1/2 Specify GRADE 5 if ordering part locally.
16	97074	2	S	Ball Bearing
17	20896	1	S	Tiller Shaft (Incl. Ref. 18)
18	1104	1	S	Woodruff Key, 1/4 x 1-1/4
19	20913	1	S	Tiller Drive Worm Gear (bronze)