

# OWNER'S MANUAL

MODEL NO. WE12538K

12.5 HP 38 Inch

Lawn Tractor

- **Assembly**
  - **Operation**
    - **Customer Responsibilities**
      - **Service and Adjustments**
        - **Storage**
          - **Troubleshooting**
            - **Repair Parts**

For Parts and Service, contact our authorized distributor: call 1-800-849-1297  
For Technical Assistance: call 1-800-829-5886

---

# WEED EATER®

# SAFETY RULES



## SAFE OPERATION PRACTICES FOR RIDE-ON MOWERS



**IMPORTANT:** THIS CUTTING MACHINE IS CAPABLE OF AMPUTATING HANDS AND FEET AND THROWING OBJECTS. FAILURE TO OBSERVE THE FOLLOWING SAFETY INSTRUCTIONS COULD RESULT IN SERIOUS INJURY OR DEATH.

### I. GENERAL OPERATION

- Read, understand, and follow all instructions in the manual and on the machine before starting.
- Only allow responsible adults, who are familiar with the instructions, to operate the machine.
- Clear the area of objects such as rocks, toys, wire, etc., which could be picked up and thrown by the blade.
- Be sure the area is clear of other people before mowing. Stop machine if anyone enters the area.
- Never carry passengers.
- Do not mow in reverse unless absolutely necessary. Always look down and behind before and while backing.
- Be aware of the mower discharge direction and do not point it at anyone. Do not operate the mower without either the entire grass catcher or the guard in place.
- Slow down before turning.
- Never leave a running machine unattended. Always turn off blades, set parking brake, stop engine, and remove keys before dismounting.
- Turn off blades when not mowing.
- Stop engine before removing grass catcher or unclogging chute.
- Mow only in daylight or good artificial light.
- Do not operate the machine while under the influence of alcohol or drugs.
- Watch for traffic when operating near or crossing roadways.
- Use extra care when loading or unloading the machine into a trailer or truck.
- Data indicates that operators, age 60 years and above, are involved in a large percentage of riding mower-related injuries. These operators should evaluate their ability to operate the riding mower safely enough to protect themselves and others from serious injury.
- Keep machine free of grass, leaves or other debris build-up which can touch hot exhaust / engine parts and burn. Do not allow the mower deck to plow leaves or other debris which can cause build-up to occur. Clean any oil or fuel spillage before operating or storing the machine. Allow machine to cool before storage.

### II. SLOPE OPERATION

Slopes are a major factor related to loss-of-control and tipover accidents, which can result in severe injury or death. All slopes require extra caution. If you cannot back up the slope or if you feel uneasy on it, do not mow it.

#### DO:

- Mow up and down slopes, not across.
- Remove obstacles such as rocks, tree limbs, etc.
- Watch for holes, ruts, or bumps. Uneven terrain could overturn the machine. *Tall grass can hide obstacles.*
- Use slow speed. Choose a low gear so that you will not have to stop or shift while on the slope.
- Follow the manufacturer's recommendations for wheel weights or counterweights to improve stability.
- Use extra care with grass catchers or other attachments. These can change the stability of the machine.
- Keep all movement on the slopes *slow* and *gradual*. Do not make sudden changes in speed or direction.

- Avoid starting or stopping on a slope. If tires lose traction, disengage the blades and proceed slowly *straight* down the slope.

#### DO NOT:

- *Do not* turn on slopes unless necessary, and then, turn slowly and gradually downhill, if possible.
- *Do not* mow near drop-offs, ditches, or embankments. The mower could suddenly turn over if a wheel is over the edge of a cliff or ditch, or if an edge caves in.
- *Do not* mow on wet grass. Reduced traction could cause sliding.
- *Do not* try to stabilize the machine by putting your foot on the ground.
- *Do not* use grass catcher on steep slopes.

### III. CHILDREN

Tragic accidents can occur if the operator is not alert to the presence of children. Children are often attracted to the machine and the mowing activity. *Never* assume that children will remain where you last saw them.

- Keep children out of the mowing area and under the watchful care of another responsible adult.
- Be alert and turn machine off if children enter the area.
- Before and when backing, look behind and *down* for small children.
- Never carry children. They may fall off and be seriously injured or interfere with safe machine operation.
- Never allow children to operate the machine.
- Use extra care when approaching blind corners, shrubs, trees, or other objects that may obscure vision.

### IV. SERVICE

- Use extra care in handling gasoline and other fuels. They are flammable and vapors are explosive.
  - Use only an approved container.
  - Never remove gas cap or add fuel with the engine running. Allow engine to cool before refueling. Do not smoke.
  - Never refuel the machine indoors.
  - Never store the machine or fuel container inside where there is an open flame, such as a water heater.
- Never run a machine inside a closed area.
- Keep nuts and bolts, especially blade attachment bolts, tight and keep equipment in good condition.
- Never tamper with safety devices. Check their proper operation regularly.
- Keep machine free of grass, leaves, or other debris build-up. Clean oil or fuel spillage. Allow machine to cool before storing.
- Stop and inspect the equipment if you strike an object. Repair, if necessary, before restarting.
- Never make adjustments or repairs with the engine running.
- Grass catcher components are subject to wear, damage, and deterioration, which could expose moving parts or allow objects to be thrown. Frequently check components and replace with manufacturer's recommended parts, when necessary.
- Mower blades are sharp and can cut. Wrap the blade(s) or wear gloves, and use extra caution when servicing them.
- Check brake operation frequently. Adjust and service as required.

## SAFETY RULES

### Safe Operation Practices for Ride-On Mowers



- Be sure the area is clear of other people before mowing. Stop machine if anyone enters the area.
- Never carry passengers or children even with the blades off.
- Do not mow in reverse unless absolutely necessary. Always look down and behind before and while backing.
- Never carry children. They may fall off and be seriously injured or interfere with safe machine operation.
- Keep children out of the mowing area and under the watchful care of another responsible adult.
- Be alert and turn machine off if children enter the area.
- Before and when backing, look behind and down for small children.
- Mow up and down slopes (15° Max), not across.
- Remove obstacles such as rocks, tree limbs, etc.
- Watch for holes, ruts, or bumps. Uneven terrain could overturn the machine. Tall grass can hide obstacles.
- Use slow speed. Choose a low gear so that you will not have to stop or shift while on the slope.
- Avoid starting or stopping on a slope. If tires lose traction, disengage the blades and proceed slowly straight down the slope.
- If machine stops while going uphill, disengage blades, shift into reverse and back down slowly.
- Do not turn on slopes unless necessary, and then, turn slowly and gradually downhill, if possible.



Look for this symbol to point out important safety precautions. It means **CAUTION!!! BECOME ALERT!!! YOUR SAFETY IS INVOLVED.**



**CAUTION:** In order to prevent accidental starting when setting up, transporting, adjusting or making repairs, always disconnect spark plug wire and place wire where it cannot contact spark plug.



**CAUTION:** Do not coast down a hill in neutral, you may lose control of the tractor.



**CAUTION:** Tow only the attachments that are recommended by and comply with specifications of the manufacturer of your tractor. Use common sense when towing. Operate only at the lowest possible speed when on a slope. Too heavy of a load, while on a slope, is dangerous. Tires can lose traction with the ground and cause you to lose control of your tractor.



### WARNING



Engine exhaust, some of its constituents, and certain vehicle components contain or emit chemicals known to the State of California to cause cancer and birth defects or other reproductive harm.



### WARNING



Battery posts, terminals and related accessories contain lead and lead compounds, chemicals known to the State of California to cause cancer and birth defects or other reproductive harm. Wash hands after handling.

## PRODUCT SPECIFICATIONS

GASOLINE CAPACITY AND TYPE:	1.25 GALLONS UNLEADED REGULAR
OIL TYPE (API-SF-SJ):	SAE 30 (above 32°F) SAE 5W-30 (below 32°F)
OIL CAPACITY:	3 PINTS
SPARK PLUG: (GAP: .030")	CHAMPION RJ19LM
GROUND SPEED (MPH):	FORWARD: 1st 1.1 2nd 2.2 3rd 3.3 4th 4.4 5th 4.9 REVERSE: 1.4
TIRE PRESSURE:	FRONT: 14 PSI REAR: 12 PSI
CHARGING SYSTEM:	3 AMPS BATTERY 5 AMPS HEADLIGHTS
BATTERY:	AMP/HR: 28 MIN. CCA: 230 CASE SIZE: U1R
BLADE BOLT TORQUE:	27-35 FT. LBS.

**CONGRATULATIONS** on your purchase of a new tractor. It has been designed, engineered and manufactured to give you the best possible dependability and performance.

Should you experience any problem you cannot easily remedy, please contact your nearest authorized service center/department. We have competent, well-trained technicians and the proper tools to service or repair this tractor.

Please read and retain this manual. The instructions will enable you to assemble and maintain your tractor properly. Always observe the "SAFETY RULES".

## CUSTOMER RESPONSIBILITIES

- Read and observe the safety rules.
- Follow a regular schedule in maintaining, caring for and using your tractor.
- Follow the instructions under "Customer Responsibilities" and "Storage" sections of this owner's manual.

**WARNING:** This tractor is equipped with an internal combustion engine and should not be used on or near any unimproved forest-covered, brush-covered or grass-covered land unless the engine's exhaust system is equipped with a spark arrester meeting applicable local or state laws (if any). If a spark arrester is used, it should be maintained in effective working order by the operator.

A spark arrester for the muffler is available through your nearest authorized service center/department (See REPAIR PARTS section of this manual).

---

## TABLE OF CONTENTS

---

SAFETY RULES .....	2-3	SERVICE AND ADJUSTMENTS .....	19-23
PRODUCT SPECIFICATIONS .....	4	STORAGE .....	24
CUSTOMER RESPONSIBILITIES .....	4, 14-18	TROUBLESHOOTING .....	25-26
ASSEMBLY .....	6-8	REPAIR PARTS .....	28-43
OPERATION .....	9-13	WARRANTY .....	45-46
MAINTENANCE SCHEDULE .....	14		

# UNASSEMBLED PARTS

## Steering Wheel

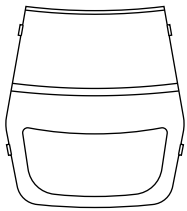
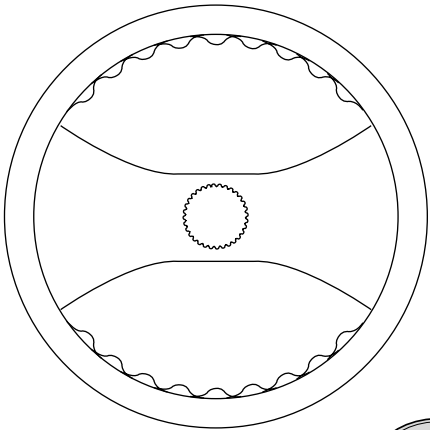

Steering Wheel  
Insert

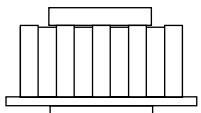

Steering Wheel  
Adapter



Steering  
Extension  
Shaft

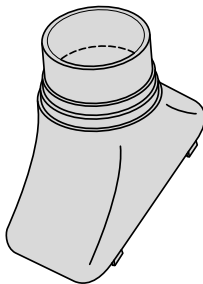

Steering  
Boot

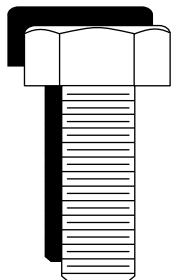

(1) Hex Bolt  
3/8-16 x 1



(1) Lockwasher 3/8

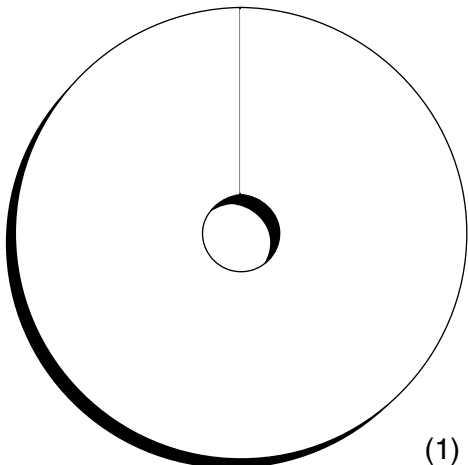

(1) Large Flat Washer

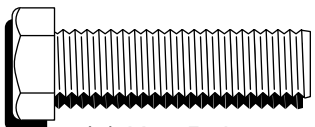

(1) Hex Bolt  
5/16-18 x 1-1/4



(1) Locknut  
5/16-18

## Seat

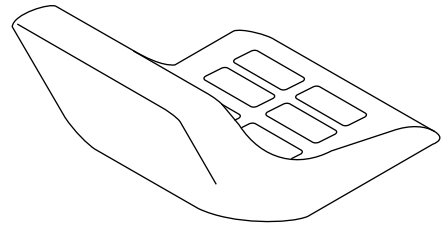

(1) Washer  
17/32 x 1-3/16 x 12 Gauge



(1) Lock  
Washer 1/2



(1) Bolt



(1) Oil Drain Tube  
For Future Use

## Keys

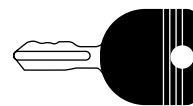

(2) Keys

## Slope Sheet

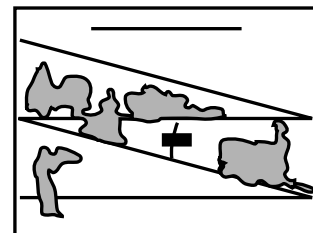

# ASSEMBLY

Your new tractor has been assembled at the factory with exception of those parts left unassembled for shipping purposes. To ensure safe and proper operation of your tractor all parts and hardware you assemble must be tightened securely. Use the correct tools as necessary to insure proper tightness.

## TOOLS REQUIRED FOR ASSEMBLY

A socket wrench set will make assembly easier. Standard wrench sizes are listed.

- |                   |                     |
|-------------------|---------------------|
| (2) 1/2" wrenches | Pliers              |
| (1) 9/16" wrench  | Tire pressure gauge |
| Utility knife     |                     |

When right or left hand is mentioned in this manual, it means when you are in the operating position (seated behind the steering wheel).

## TO REMOVE TRACTOR FROM CARTON

### UNPACK CARTON

- Remove all accessible loose parts and parts cartons from carton.
- Cut, from top to bottom, along lines on all four corners of carton, and lay panels flat.
- Check for any additional loose parts or cartons and remove.

## BEFORE REMOVING TRACTOR FROM SKID

### ATTACH STEERING WHEEL (See Fig. 1)

#### ASSEMBLE EXTENSION SHAFT AND BOOT

- Slide extension shaft onto lower steering shaft. Align mounting holes in extension and lower shafts and install 5/16 hex bolt and locknut. Tighten securely.

**IMPORTANT:** TIGHTEN BOLT AND NUT SECURELY TO 18-22 FT. LBS TORQUE.

- Place tabs of steering boot over tab slots in dash and push down to secure.

#### INSTALL STEERING WHEEL

- Position front wheels of the tractor so they are pointing straight forward.
- Remove steering wheel adapter from steering wheel and slide adapter onto steering shaft extension.
- Position steering wheel so cross bars are horizontal (left to right) and slide inside boot and onto adapter.
- Assemble large flat washer, 3/8 lock washer, 3/8 hex bolt and tighten securely.
- Snap steering wheel insert into center of steering wheel.
- Remove protective materials from tractor hood and grill.

**IMPORTANT:** CHECK FOR AND REMOVE ANY STAPLES IN SKID THAT MAY PUNCTURE TIRES WHERE TRACTOR IS TO ROLL OFF SKID.

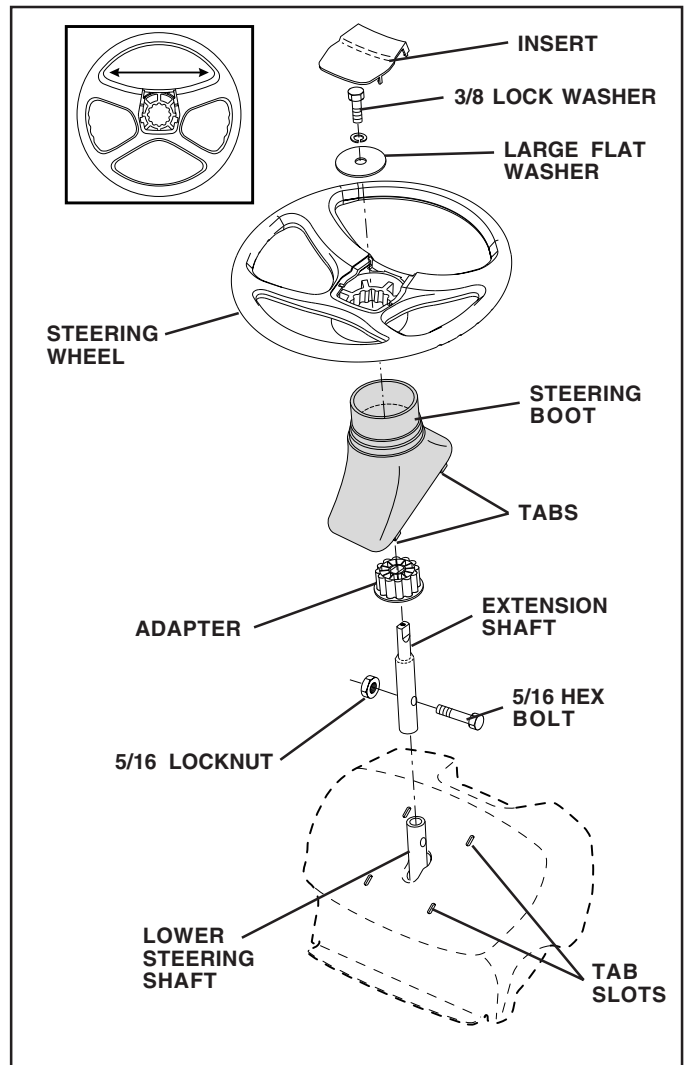

FIG. 1

# ASSEMBLY

## HOW TO SET UP YOUR TRACTOR

### CHECK BATTERY (See Fig. 2)

- Lift seat pan to raised position.
- If this battery is put into service after month and year indicated on label (label located between terminals) charge battery for minimum of one hour at 6-10 amps. (See "BATTERY" in the Customer Responsibilities section of this manual for charging instructions).

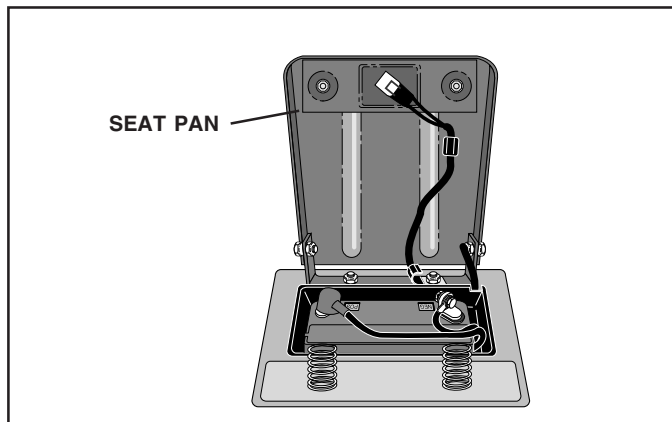

FIG. 2

### INSTALL SEAT (See Fig. 3)

Adjust seat before tightening adjustment bolt.

- Remove adjustment bolt, lock washer and flat washer securing seat to cardboard packing and set aside for assembly of seat to tractor.
- Pivot seat upward and remove from the cardboard packing. Remove the cardboard packing and discard.
- Place seat on seat pan so head of shoulder bolt is positioned over large slotted hole in pan.
- Push down on seat to engage shoulder bolt in slot and pull seat towards rear of tractor.
- Pivot seat and pan forward and assemble adjustment bolt, lockwasher and flat washer loosely. Do not tighten.
- Lower seat into operating position and sit on seat.
- Slide seat until a comfortable position is reached which allows you to press clutch/brake pedal all the way down.
- Get off seat without moving its adjusted position.
- Raise seat and tighten adjustment bolt securely.

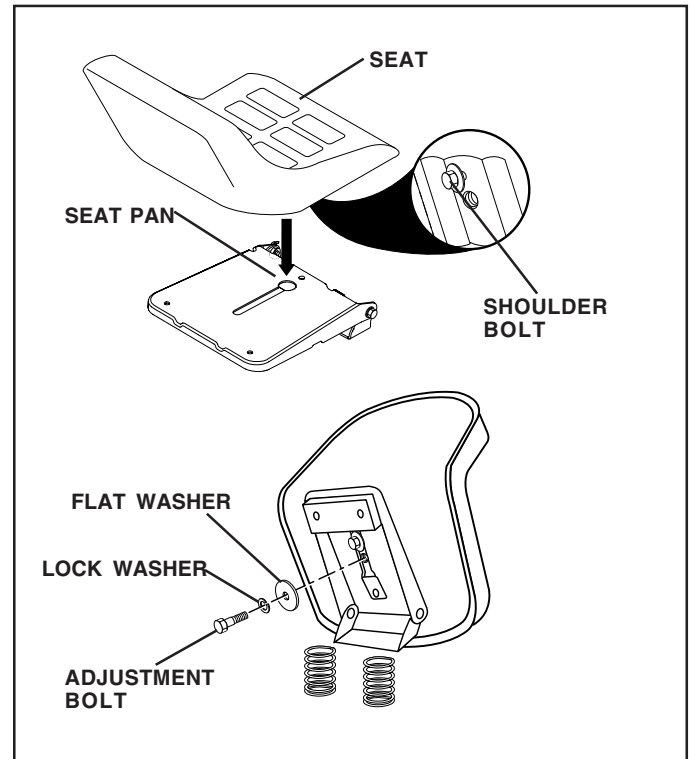

FIG. 3

**NOTE:** You may now roll or drive your tractor off the skid. Follow the appropriate instruction below to remove the tractor from the skid.

### TO ROLL TRACTOR OFF SKID (See Operation section, page 10, for location and function of controls)

- Press lift lever plunger and raise attachment lift lever to its highest position.
- Release parking brake by depressing clutch/brake pedal.
- Place gearshift lever in neutral (N) position.
- Roll tractor forward off skid.
- Remove banding holding deflector shield up against tractor.

# ASSEMBLY

## TO DRIVE TRACTOR OFF SKID (See Operation section, page 10, for location and function of controls)

**▲WARNING:** Before starting, read, understand and follow all instructions in the Operation section of this manual. Be sure tractor is in a well-ventilated area. Be sure the area in front of tractor is clear of other people and objects.

- Be sure all the above assembly steps have been completed.
- Check engine oil level and fill fuel tank with gasoline.
- Sit on seat in operating position, depress clutch/brake pedal and set the parking brake.
- Place gear shift lever in neutral (N) position.
- Press lift lever plunger and raise attachment lift lever to its highest position.
- Start the engine. After engine has started, move throttle control to idle position.
- Depress clutch/brake pedal into full "BRAKE" position and hold. Move gearshift lever to 1st gear.
- Slowly release clutch/brake pedal and slowly drive tractor off skid.
- Apply brake to stop tractor, set parking brake and place gearshift lever in neutral position.
- Turn ignition key to "OFF" position.

Continue with the instructions that follow.

## CHECK TIRE PRESSURE

The tires on your tractor were overinflated at the factory for shipping purposes. Correct tire pressure is important for best cutting performance.

- Reduce tire pressure to PSI shown in "PRODUCT SPECIFICATIONS" section of this manual.

## CHECK DECK LEVELNESS

For best cutting results, mower housing should be properly leveled. See "TO LEVEL MOWER HOUSING" in the Service and Adjustments section of this manual.

## CHECK FOR PROPER POSITION OF ALL BELTS

See the figures that are shown for replacing motion and mower blade drive belts in the Service and Adjustments section of this manual. Verify that the belts are routed correctly.

## CHECK BRAKE SYSTEM

After you learn how to operate your tractor, check to see that the brake is properly adjusted. See "TO ADJUST BRAKE" in the Service and Adjustments section of this manual.

## ✓ CHECKLIST

*BEFORE YOU OPERATE AND ENJOY YOUR NEW TRACTOR, WE WISH TO ASSURE THAT YOU RECEIVE THE BEST PERFORMANCE AND SATISFACTION FROM THIS QUALITY PRODUCT.*

*PLEASE REVIEW THE FOLLOWING CHECKLIST:*

- ✓ All assembly instructions have been completed.
- ✓ No remaining loose parts in carton.
- ✓ Battery is properly prepared and charged. (Minimum 1 hour at 6 amps).
- ✓ Seat is adjusted comfortably and tightened securely.
- ✓ All tires are properly inflated. (For shipping purposes, the tires were overinflated at the factory).
- ✓ Be sure mower deck is properly leveled side-to-side/front-to-rear for best cutting results. (Tires must be properly inflated for leveling).
- ✓ Check mower and drive belts. Be sure they are routed properly around pulleys and inside all belt keepers.
- ✓ Check wiring. See that all connections are still secure and wires are properly clamped.

*WHILE LEARNING HOW TO USE YOUR TRACTOR, PAY EXTRA ATTENTION TO THE FOLLOWING IMPORTANT ITEMS:*

- ✓ Engine oil is at proper level.
- ✓ Fuel tank is filled with fresh, clean, regular unleaded gasoline.
- ✓ Become familiar with all controls - their location and function. Operate them before you start the engine.
- ✓ Be sure brake system is in safe operating condition.



# OPERATION

These symbols may appear on your tractor or in literature supplied with the product. Learn and understand their meaning.

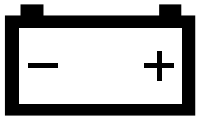

BATTERY



CAUTION OR WARNING



REVERSE



FORWARD



FAST



SLOW



ENGINE ON



ENGINE OFF



OIL PRESSURE

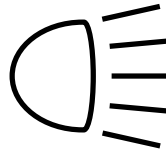

LIGHTS ON



OVER TEMP LIGHT

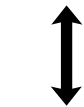

MOWER LIFT



FUEL

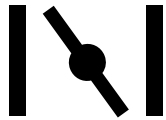

CHOKE

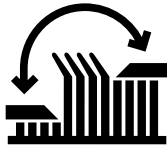

MOWER HEIGHT



PARKING BRAKE LOCKED



UNLOCKED



ATTACHMENT CLUTCH ENGAGED



REVERSE



NEUTRAL



HIGH



LOW

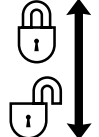

PARKING BRAKE



IGNITION



ATTACHMENT CLUTCH DISENGAGED



KEEP AREA CLEAR

SLOPE HAZARDS

(SEE SAFETY RULES SECTION)



DANGER, KEEP HANDS AND FEET AWAY

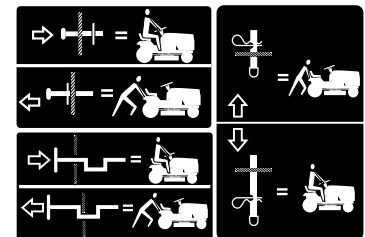

FREE WHEEL  
(Automatic Models only)

# OPERATION

## KNOW YOUR TRACTOR

### READ THIS OWNER'S MANUAL AND SAFETY RULES BEFORE OPERATING YOUR TRACTOR

Compare the illustrations with your tractor to familiarize yourself with the locations of various controls and adjustments. Save this manual for future reference.

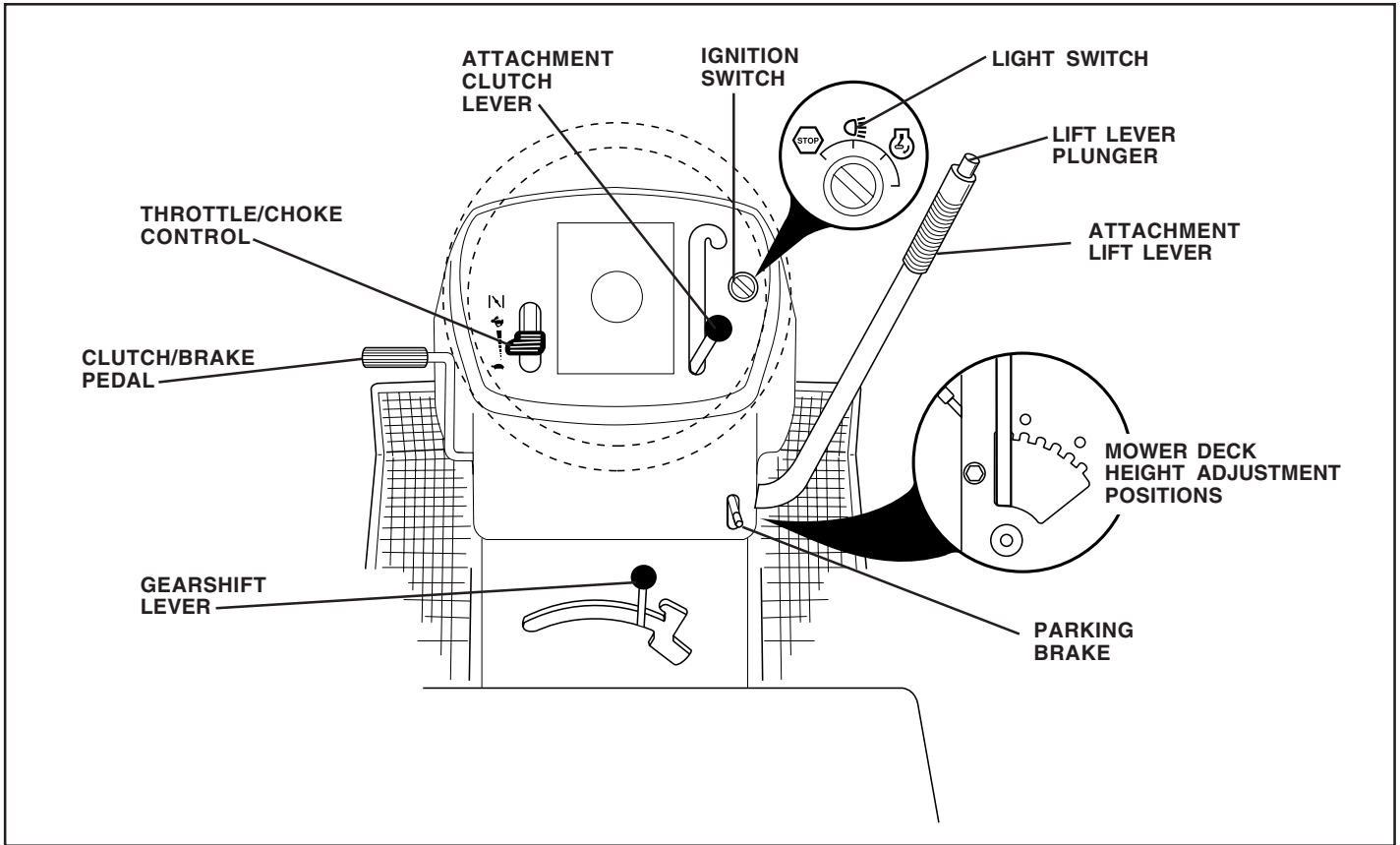

FIG. 4

Our tractors conform to the safety standards of the American National Standards Institute.

**ATTACHMENT CLUTCH LEVER:** Used to engage the mower blades, or other attachments mounted to your tractor.

**LIGHT SWITCH:** Turns the headlights on and off.

**THROTTLE/CHOKE CONTROL:** Used for starting and controlling engine speed.

**CLUTCH/BRAKE PEDAL:** Used for declutching and braking the tractor and starting the engine.

**PARKING BRAKE:** Locks clutch/brake pedal into the brake position.

**GEARSHIFT LEVER:** Selects the speed and direction of tractor.

**ATTACHMENT LIFT LEVER:** Used to raise, lower, and adjust the mower deck or other attachments mounted to your tractor.

**LIFT LEVER PLUNGER:** Used to release attachment lift lever when changing its position.

**IGNITION SWITCH:** Used for starting and stopping the engine.

# OPERATION



The operation of any tractor can result in foreign objects thrown into the eyes, which can result in severe eye damage. Always wear safety glasses or eye shields while operating your tractor or performing any adjustments or repairs. We recommend a wide vision safety mask over spectacles or standard safety glasses.

## HOW TO USE YOUR TRACTOR

### TO SET PARKING BRAKE (See Fig. 5)

Your tractor is equipped with an operator presence sensing switch. When engine is running, any attempt by the operator to leave the seat without first setting the parking brake will shut off the engine.

- Depress clutch/brake pedal into full "BRAKE" position and hold.
- Place parking brake lever in "ENGAGED" position and release pressure from clutch/brake pedal. Pedal should remain in "BRAKE" position. Make sure parking brake will hold tractor secure.

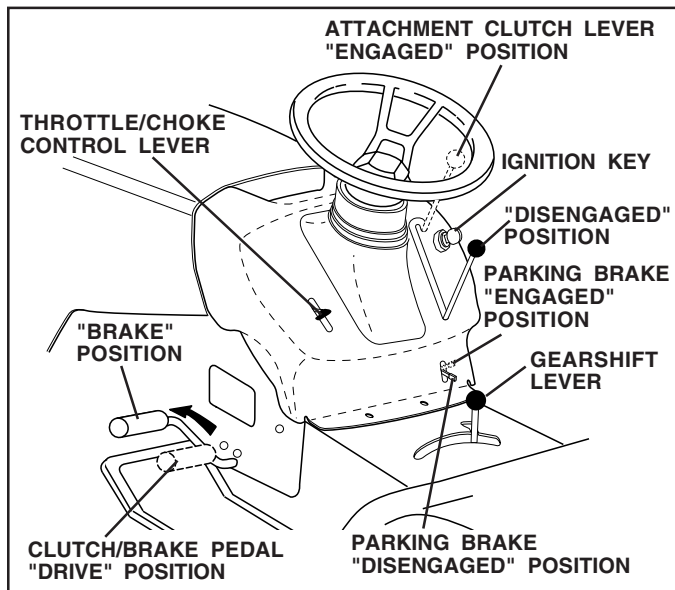

FIG.5

### STOPPING (See Fig. 5)

#### MOWER BLADES -

- To stop mower blades, move attachment clutch lever to "DISENGAGED" position.

#### GROUND DRIVE -

- To stop ground drive, depress clutch/brake pedal into full "BRAKE" position.
- Move gearshift lever to neutral (N) position.

#### ENGINE -

- Move throttle control to slow position.

**NOTE:** Failure to move throttle control to slow position and allowing engine to idle before stopping may cause engine to "backfire".

- Turn ignition key to "OFF" position and remove key. Always remove key when leaving tractor to prevent unauthorized use.
- Never use choke to stop engine.

**IMPORTANT:** LEAVING THE IGNITION SWITCH IN ANY POSITION OTHER THAN "OFF" WILL CAUSE THE BATTERY TO BE DISCHARGED, (DEAD).

**NOTE:** Under certain conditions when tractor is standing idle with the engine running, hot engine exhaust gases may cause "browning" of grass. To eliminate this possibility, always stop engine when stopping tractor on grass areas.



**CAUTION:** Always stop tractor completely, as described above, before leaving the operator's position; to empty grass catcher, etc.

### TO USE THROTTLE CONTROL (See Fig. 5)

Always operate engine at full throttle.

- Operating engine at less than full throttle reduces the battery charging rate.
- Full throttle offers the best bagging and mower performance.

### TO MOVE FORWARD AND BACKWARD (See Fig. 5)

The direction and speed of movement is controlled by the gearshift lever.

- Start tractor with clutch/brake pedal depressed and gearshift lever in neutral (N) position.
- Move gearshift lever to desired position.
- Slowly release clutch/brake pedal to start movement.

**IMPORTANT:** BRING TRACTOR TO A COMPLETE STOP BEFORE SHIFTING OR CHANGING GEARS. FAILURE TO DO SO WILL SHORTEN THE USEFUL LIFE OF YOUR TRANSAXLE.

### TO ADJUST MOWER CUTTING HEIGHT (See Fig. 5)

The position of the attachment lift lever determines the cutting height.

- Grasp lift lever.
- Press plunger with thumb and move lever to desired position.

The cutting height range is approximately 1-1/2 to 4". The heights are measured from the ground to the blade tip with the engine not running. These heights are approximate and may vary depending upon soil conditions, height of grass and types of grass being mowed.

- The average lawn should be cut to approximately 2-1/2 inches during the cool season and to over 3 inches during hot months. For healthier and better looking lawns, mow often and after moderate growth.
- For best cutting performance, grass over 6 inches in height should be mowed twice. Make the first cut relatively high; the second to desired height.

# OPERATION

## TO OPERATE MOWER (See Fig. 6)

Your tractor is equipped with an operator presence sensing switch. Any attempt by the operator to leave the seat with the engine running and the attachment clutch engaged will shut off the engine.

- Select desired height of cut.
- Start mower blades by engaging attachment clutch control.
- TO STOP MOWER BLADES - disengage attachment clutch control.



**CAUTION:** Do not operate the mower without either the entire grass catcher, on mowers so equipped, or the deflector shield in place.

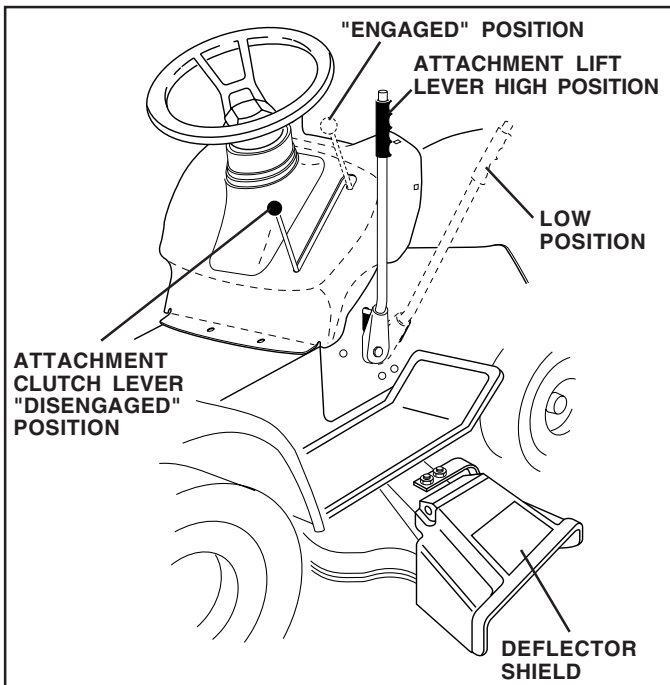

FIG. 6

## TO OPERATE ON HILLS



**CAUTION:** Do not drive up or down hills with slopes greater than 15° and do not drive across any slope.

- Choose the slowest speed before starting up or down hills.
- Avoid stopping or changing speed on hills.
- If slowing is necessary, move throttle control lever to slower position.
- If stopping is absolutely necessary, push clutch/brake pedal quickly to brake position and engage parking brake.
- Move gearshift lever to 1st gear. Be sure you have allowed room for tractor to roll slightly as you restart movement.
- To restart movement, slowly release parking brake and clutch/brake pedal.
- Make all turns slowly.

## TO TRANSPORT

- Raise attachment lift to highest position with attachment lift control.
- When pushing or towing your tractor, be sure gearshift lever is in neutral (N) position.
- Do not push or tow tractor at more than five (5) MPH.

**NOTE:** To protect hood from damage when transporting your tractor on a truck or a trailer, be sure hood is closed and secured to tractor. Use an appropriate means of tying hood to tractor (rope, cord, etc.).

## TOWING CARTS AND OTHER ATTACHMENTS

Tow only the attachments that are recommended by and comply with specifications of the manufacturer of your tractor. Use common sense when towing. Too heavy of a load, while on a slope, is dangerous. Tires can lose traction with the ground and cause you to lose control of your tractor.

## BEFORE STARTING THE ENGINE

### CHECK ENGINE OIL LEVEL

- The engine in your tractor has been shipped, from the factory, already filled with summer weight oil.
- Check engine oil with tractor on level ground.
- Remove oil fill cap/dipstick and wipe clean, reinsert the dipstick and screw cap tight, wait for a few seconds, remove and read oil level. If necessary, add oil until "FULL" mark on dipstick is reached. Do not overfill.
- For cold weather operation you should change oil for easier starting (See "OIL VISCOSITY CHART" in the Customer Responsibilities section of this manual).
- To change engine oil, see the Customer Responsibilities section in this manual.

### ADD GASOLINE

- Fill fuel tank. Use fresh, clean, regular unleaded gasoline with a minimum of 87 octane. (Use of leaded gasoline will increase carbon and lead oxide deposits and reduce valve life). Do not mix oil with gasoline. Purchase fuel in quantities that can be used within 30 days to assure fuel freshness.

**IMPORTANT:** WHEN OPERATING IN TEMPERATURES BELOW 32°F(0°C), USE FRESH, CLEAN WINTER GRADE GASOLINE TO HELP INSURE GOOD COLD WEATHER STARTING.

**WARNING:** Experience indicates that alcohol blended fuels (called gasohol or using ethanol or methanol) can attract moisture which leads to separation and formation of acids during storage. Acidic gas can damage the fuel system of an engine while in storage. To avoid engine problems, the fuel system should be emptied before storage of 30 days or longer. Drain the gas tank, start the engine and let it run until the fuel lines and carburetor are empty. Use fresh fuel next season. See Storage Instructions for additional information. Never use engine or carburetor cleaner products in the fuel tank or permanent damage may occur.



**CAUTION:** Fill to bottom of gas tank filler neck. Do not overfill. Wipe off any spilled oil or fuel. Do not store, spill or use gasoline near an open flame.

# OPERATION

## TO START ENGINE (See Fig. 5)

When starting the engine for the first time or if the engine has run out of fuel, it will take extra cranking time to move fuel from the tank to the engine.

- Sit on seat in operating position, depress clutch/brake pedal and set parking brake.
- Place gear shift lever in neutral (N) position.
- Move attachment clutch to "DISENGAGED" position.
- Move throttle control to choke position.

**NOTE:** Before starting, read the warm and cold starting procedures below.

- Insert key into ignition and turn key clockwise to "START" position and release key as soon as engine starts. Do not run starter continuously for more than fifteen seconds per minute. If the engine does not start after several attempts, move throttle control to fast position, wait a few minutes and try again. If engine still does not start, move the throttle control back to the choke position and retry.

### WARM WEATHER STARTING (50° F and above)

- When engine starts, move the throttle control to the fast position.
- The attachments and ground drive can now be used. If the engine does not accept the load, restart the engine and allow it to warm up for one minute using the choke as described above.

### COLD WEATHER STARTING (50° F and below)

- When engine starts, allow engine to run with the throttle control in the choke position until the engine runs roughly, then move throttle control to fast position. This may require an engine warm-up period from several seconds to several minutes, depending on the temperature.
- The attachments can also be used during the engine warm-up period.

**NOTE:** If at a high altitude (above 3000 feet) or in cold temperatures (below 32 F) the carburetor fuel mixture may need to be adjusted for best engine performance. See "TO ADJUST CARBURETOR" in the Service and Adjustments section of this manual.

## MOWING TIPS

- Tire chains cannot be used when the mower housing is attached to tractor.
- Mower should be properly leveled for best mowing performance. See "TO LEVEL MOWER HOUSING" in the Service and Adjustments section of this manual.
- The left hand side of mower should be used for trimming.
- Drive so that clippings are discharged onto the area that has been cut. Have the cut area to the right of the machine. This will result in a more even distribution of clippings and more uniform cutting.
- When mowing large areas, start by turning to the right so that clippings will discharge away from shrubs, fences, driveways, etc. After one or two rounds, mow in the opposite direction making left hand turns until finished (See Fig. 7).

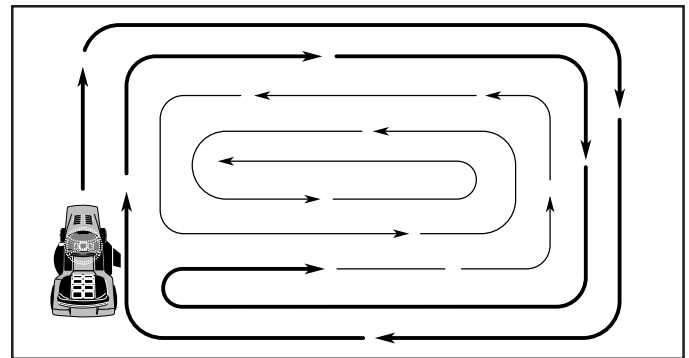

FIG. 7

- If grass is extremely tall, it should be mowed twice to reduce load and possible fire hazard from dried clippings. Make first cut relatively high; the second to the desired height.
- Do not mow grass when it is wet. Wet grass will plug mower and leave undesirable clumps. Allow grass to dry before mowing.
- **Always operate engine at full throttle when mowing** to assure better mowing performance and proper discharge of material. Regulate ground speed by selecting a low enough gear to give the mower cutting performance as well as the quality of cut desired.
- When operating attachments, select a ground speed that will suit the terrain and give best performance of the attachment being used.

# CUSTOMER RESPONSIBILITIES

MAINTENANCE SCHEDULE		SERVICE INTERVALS						SERVICE DATES	
		BEFORE EACH USE	EVERY 8 HOURS	EVERY 25 HOURS	EVERY 50 HOURS	EVERY 100 HOURS	EVERY SEASON		
TRACTOR	Check Brake Operation	✓	✓						
	Check Tire Pressure	✓	✓						
	Check Operator Presence and Interlock Systems	✓							
	Check for Loose Fasteners	✓			✓ <sub>5</sub>	✓			
	Sharpen/Replace Mower Blades			✓ <sub>3</sub>					
	Lubrication Chart			✓			✓		
	Check Battery Level			✓ <sub>4</sub>					
	Clean Battery and Terminals			✓			✓		
	Check Transaxle Cooling			✓					
	Check V-Belts				✓				
ENGINE	Check Engine Oil Level	✓	✓						
	Change Engine Oil (with oil filter)				✓ <sub>1,2</sub>		✓		
	Change Engine Oil (without oil filter)			✓ <sub>1,2</sub>			✓		
	Clean Air Filter			✓ <sub>2</sub>					
	Clean Air Screen			✓ <sub>2</sub>					
	Inspect Muffler/Spark Arrester				✓				
	Replace Oil Filter (If equipped)					✓ <sub>1,2</sub>			
	Clean Engine Cooling Fins					✓ <sub>2</sub>			
	Replace Spark Plug					✓	✓		
	Replace Air Filter Paper Cartridge					✓ <sub>2</sub>			
Replace Fuel Filter						✓			

1 - Change more often when operating under a heavy load or in high ambient temperatures.  
 2 - Service more often when operating in dirty or dusty conditions.

3 - Replace blades more often when mowing in sandy soil.  
 4 - Not required if equipped with maintenance-free battery.  
 5 - Tighten front axle pivot bolt to 35 ft.-lbs. maximum. Do not overtighten.

## GENERAL RECOMMENDATIONS

The warranty on this tractor does not cover items that have been subjected to operator abuse or negligence. To receive full value from the warranty, operator must maintain tractor as instructed in this manual.

Some adjustments will need to be made periodically to properly maintain your tractor.

All adjustments in the Service and Adjustments section of this manual should be checked at least once each season.

- Once a year you should replace the spark plug, clean or replace air filter, and check blades and belts for wear. A new spark plug and clean air filter assure proper air-fuel mixture and help your engine run better and last longer.

## BEFORE EACH USE

- Check engine oil level.
- Check brake operation.
- Check tire pressure.
- Check operator presence and interlock systems for proper operation.
- Check for loose fasteners.

## LUBRICATION CHART

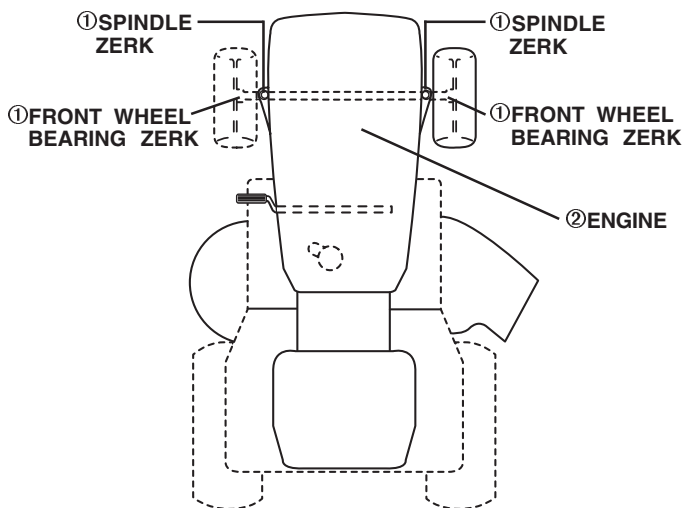

① GENERAL PURPOSE GREASE  
 ② REFER TO CUSTOMER RESPONSIBILITIES "ENGINE" SECTION

**IMPORTANT:** DO NOT OIL OR GREASE THE PIVOT POINTS WHICH HAVE SPECIAL NYLON BEARINGS. VISCOUS LUBRICANTS WILL ATTRACT DUST AND DIRT THAT WILL SHORTEN THE LIFE OF THE SELF-LUBRICATING BEARINGS. IF YOU FEEL THEY MUST BE LUBRICATED, USE ONLY A DRY, POWDERED GRAPHITE TYPE LUBRICANT SPARINGLY.

# CUSTOMER RESPONSIBILITIES

## TRACTOR

Always observe safety rules when performing any maintenance.

## BRAKE OPERATION

If tractor requires more than six (6) feet stopping distance at high speed in highest gear, then brake must be adjusted. (See "TO ADJUST BRAKE" in the Service and Adjustments section of this manual).

## TIRES

- Maintain proper air pressure in all tires (See "PRODUCT SPECIFICATIONS" section of this manual).
- Keep tires free of gasoline, oil, or insect control chemicals which can harm rubber.
- Avoid stumps, stones, deep ruts, sharp objects and other hazards that may cause tire damage.

**NOTE:** To seal tire punctures and prevent flat tires due to slow leaks, tire sealant may be purchased from your local parts dealer. Tire sealant also prevents tire dry rot and corrosion.

## OPERATOR PRESENCE SYSTEM

Be sure operator presence and interlock systems are working properly. If your tractor does not function as described, repair the problem immediately.

- The engine should not start unless the clutch/brake pedal is fully depressed and attachment clutch control is in the disengaged position.
- When the engine is running, any attempt by the operator to leave the seat without first setting the parking brake should shut off the engine.
- When the engine is running and the attachment clutch is engaged, any attempt by the operator to leave the seat should shut off the engine.
- The attachment clutch should never operate unless the operator is in the seat.

## BLADE CARE

For best results mower blades must be kept sharp. Replace bent or damaged blades.

## BLADE REMOVAL (See Fig. 8)

- Raise mower to highest position to allow access to blades.
- Remove hex bolt, lock washer and flat washer securing blade.
- Install new or resharpened blade with trailing edge up towards deck as shown.

**IMPORTANT:** TO ENSURE PROPER ASSEMBLY, CENTER HOLE IN BLADE MUST ALIGN WITH STAR ON MANDREL ASSEMBLY.

- Reassemble hex bolt, lock washer and flat washer in exact order as shown.
- Tighten bolt securely (27-35 Ft. Lbs. torque).

**IMPORTANT:** BLADE BOLT IS GRADE 8 HEAT TREATED.

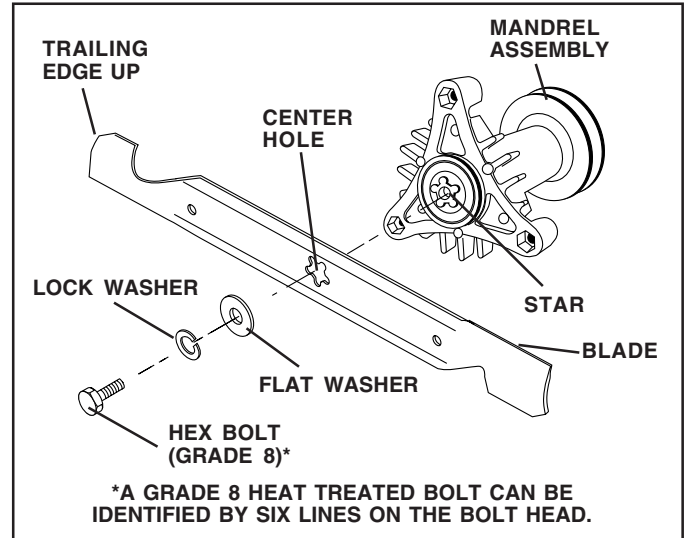

FIG. 8

## TO SHARPEN BLADE (See Fig. 9)

**NOTE:** We do not recommend sharpening blade - but if you do, be sure the blade is balanced.

Care should be taken to keep the blade balanced. An unbalanced blade will cause excessive vibration and eventual damage to mower and engine.

- The blade can be sharpened with a file or on a grinding wheel. Do not attempt to sharpen while on the mower.
- To check blade balance, you will need a 5/8" diameter steel bolt, pin, or a cone balancer. (When using a cone balancer, follow the instructions supplied with balancer).

**NOTE:** Do not use a nail for balancing blade. The lobes of the center hole may appear to be centered, but are not.

- Slide blade on to an unthreaded portion of the steel bolt or pin and hold the bolt or pin parallel with the ground. If blade is balanced, it should remain in a horizontal position. If either end of the blade moves downward, sharpen the heavy end until the blade is balanced.

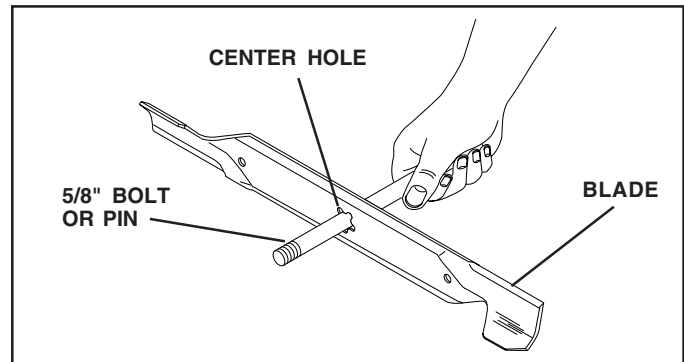

FIG. 9

# CUSTOMER RESPONSIBILITIES

## BATTERY

Your tractor has a battery charging system which is sufficient for normal use. However, periodic charging of the battery with an automotive charger will extend its life.

- Keep battery and terminals clean.
- Keep battery bolts tight.
- Keep small vent holes open.
- Recharge at 6-10 amperes for 1 hour.

**NOTE:** The original equipment battery on your tractor is maintenance free. Do not attempt to open or remove caps or covers. Adding or checking level of electrolyte is not necessary.

### TO CLEAN BATTERY AND TERMINALS

Corrosion and dirt on the battery and terminals can cause the battery to “leak” power.

- Disconnect BLACK battery cable first then RED battery cable and remove battery from tractor.
- Rinse the battery with plain water and dry.
- Clean terminals and battery cable ends with wire brush until bright.
- Coat terminals with grease or petroleum jelly.
- Reinstall battery (See “REPLACING BATTERY” in the Service and Adjustments section of this manual).

## V-BELTS

Check V-belts for deterioration and wear after 100 hours of operation and replace if necessary. The belts are not adjustable. Replace belts if they begin to slip from wear.

## TRANSAXLE COOLING

Keep transaxle free from build-up of dirt and chaff which can restrict cooling.

## ENGINE

### LUBRICATION

Only use high quality detergent oil rated with API service classification SF-SJ. Select the oil’s SAE viscosity grade according to your expected operating temperature.

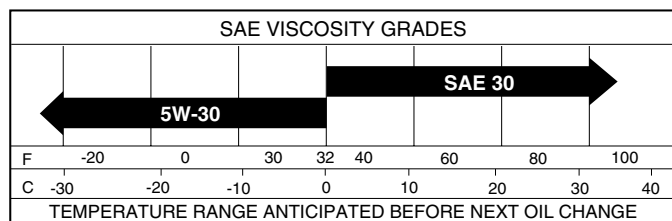

**NOTE:** Although multi-viscosity oils (5W30, 10W30 etc.) improve starting in cold weather, these multi-viscosity oils will result in increased oil consumption when used above 32°F. Check your engine oil level more frequently to avoid possible engine damage from running low on oil.

Change the oil after every 25 hours of operation or at least once a year if the tractor is not used for 25 hours in one year.

Check the crankcase oil level before starting the engine and after each eight (8) hours of operation. Tighten oil fill cap/dipstick securely each time you check the oil level.

### TO CHANGE ENGINE OIL (See Fig. 10)

Determine temperature range expected before oil change. All oil must meet API service classification SF-SJ.

- Be sure tractor is on level surface.
- Oil will drain more freely when warm.
- Catch oil in a suitable container.
- Remove oil fill cap/dipstick. Be careful not to allow dirt to enter the engine when changing oil.
- Remove yellow cap from end of drain valve and install the drain tube onto the fitting.

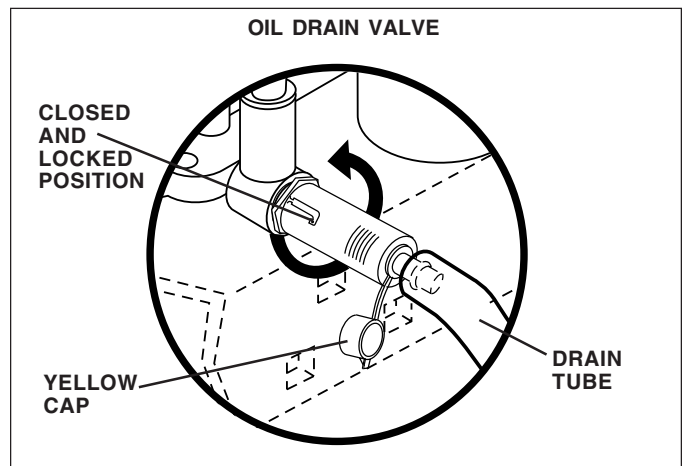

FIG. 10

- Unlock drain valve by pushing inward and turning counterclockwise.
- To open, pull out on the drain valve.
- After oil has drained completely, close and lock the drain valve by pushing inward and turning clockwise until the pin is in the locked position as shown.
- Remove the drain tube and replace the cap onto to the bottom fitting of the drain valve.
- Refill engine with oil through oil fill dipstick tube. Pour slowly. Do not overfill. For approximate capacity see “PRODUCT SPECIFICATIONS” section of this manual.
- Use gauge on oil fill cap/dipstick for checking level. Be sure dipstick cap is tightened securely for accurate reading. Keep oil at “FULL” line on dipstick.



# CUSTOMER RESPONSIBILITIES

## CLEAN AIR SCREEN

Air screen must be kept free of dirt and chaff to prevent engine damage from overheating. Clean with a wire brush or compressed air to remove dirt and stubborn dried gum fibers.

## ENGINE COOLING FINS (See Fig. 11)

Remove any dust, dirt or oil from engine cooling fins to prevent engine damage from overheating.

- Remove screws from blower housing and lift housing and dipstick tube assembly off engine.
- Cover oil fill opening to prevent entry of dirt.
- Use compressed air or stiff bristle brush to thoroughly clean engine cooling fins.
- To reassemble, reverse above procedure.

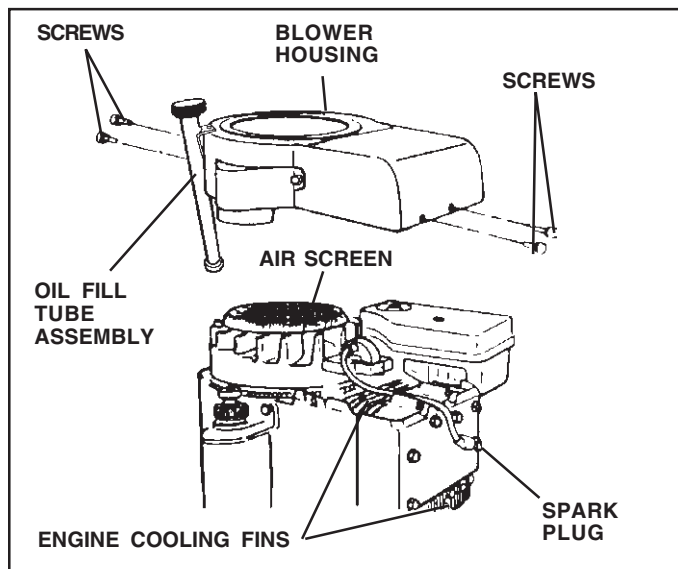

FIG. 11

## AIR FILTER (See Fig. 12)

Your engine will not run properly using a dirty air filter. Clean the foam pre-cleaner after every 25 hours of operation or every season. Service paper cartridge every 100 hours of operation or every season, whichever occurs first.

Service air cleaner more often under dusty conditions.

- Remove knob(s) and cover.

### TO SERVICE PRE-CLEANER

- Slide foam pre-cleaner off cartridge.
- Wash it in liquid detergent and water.
- Squeeze it dry in a clean cloth.
- Saturate it in engine oil. Wrap it in clean, absorbent cloth and squeeze to remove excess oil.
- If very dirty or damaged, replace pre-cleaner.
- Reinstall pre-cleaner over cartridge.
- Reinstall cover and secure with knob(s).

### TO SERVICE CARTRIDGE

- Remove cartridge nut.
- Carefully remove cartridge to prevent debris from entering carburetor. Clean base carefully to prevent debris from entering carburetor.
- Clean cartridge by tapping gently on flat surface. If very dirty or damaged, replace cartridge.
- Reinstall cartridge, nut, pre-cleaner, cover and secure with knob(s).

**IMPORTANT:** PETROLEUM SOLVENTS, SUCH AS KEROSENE, ARE NOT TO BE USED TO CLEAN THE CARTRIDGE. THEY MAY CAUSE DETERIORATION OF THE CARTRIDGE. DO NOT OIL CARTRIDGE. DO NOT USE PRESSURIZED AIR TO CLEAN OR DRY CARTRIDGE.

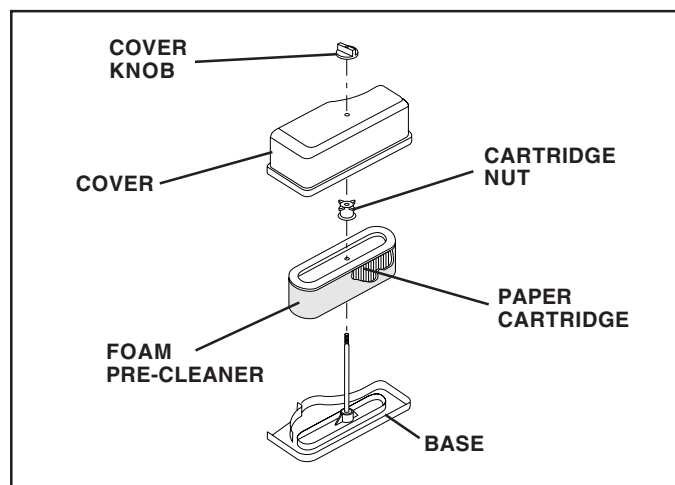

FIG. 12

## CUSTOMER RESPONSIBILITIES

### MUFFLER

Inspect and replace corroded muffler and spark arrester (if equipped) as it could create a fire hazard and/or damage.

### SPARK PLUGS

Replace spark plugs at the beginning of each mowing season or after every 100 hours of operation, whichever occurs first. Spark plug type and gap setting are shown in "PRODUCT SPECIFICATIONS" section of this manual.

### IN-LINE FUEL FILTER (See Fig. 13)

The fuel filter should be replaced once each season. If fuel filter becomes clogged, obstructing fuel flow to carburetor, replacement is required.

- With engine cool, remove filter and plug fuel line sections.
- Place new fuel filter in position in fuel line with arrow pointing towards carburetor.
- Be sure there are no fuel line leaks and clamps are properly positioned.
- Immediately wipe up any spilled gasoline.

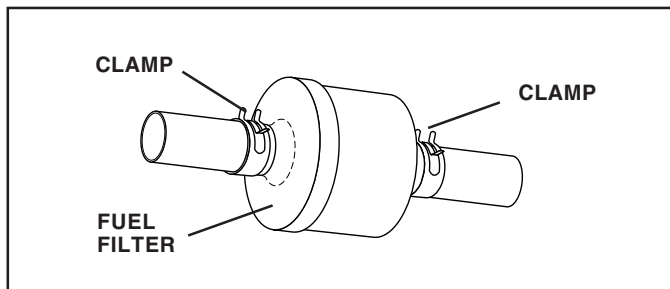

FIG. 13

### CLEANING

- Clean engine, battery, seat, finish, etc. of all foreign matter.
- Keep finished surfaces and wheels free of all gasoline, oil, etc.
- Protect painted surfaces with automotive type wax.

We do not recommend using a garden hose to clean your tractor unless the electrical system, muffler, air filter and carburetor are covered to keep water out. Water in engine can result in a shortened engine life.

# SERVICE AND ADJUSTMENTS



**CAUTION: BEFORE PERFORMING ANY SERVICE OR ADJUSTMENTS:**

- Depress clutch/brake pedal fully and set parking brake.
- Place gearshift lever in neutral (N) position.
- Place attachment clutch in “DISENGAGED” position.
- Turn ignition key “OFF” and remove key.
- Make sure the blades and all moving parts have completely stopped.
- Disconnect spark plug wire from spark plug and place wire where it cannot come in contact with plug.

**TO REMOVE MOWER (See Fig. 14)**

Mower will be easier to remove from the right side of tractor.

- Place attachment clutch in “DISENGAGED” position.
- Move attachment lift lever forward to lower mower to its lowest position.
- Roll belt off engine pulley.
- Remove small retainer spring, and lift clutch spring off pulley bolt.
- Remove large retainer spring, slide collar off and push housing guide out of bracket.
- Disconnect anti-swaybar from chassis bracket by removing retainer spring.
- Disconnect suspension arms from rear deck brackets by removing retainer springs.
- Disconnect front links from deck by removing retainer springs.
- Raise lift lever to raise suspension arms. Slide mower out from under tractor.

**IMPORTANT:** IF AN ATTACHMENT OTHER THAN THE MOWER DECK IS TO BE MOUNTED ON THE TRACTOR, REMOVE THE FRONT LINKS AND HOOK THE CLUTCH SPRING INTO SQUARE HOLE IN FRAME.

**TO INSTALL MOWER (See Fig. 14)**

- Raise attachment lift lever to its highest position.
- Slide mower under tractor with deflector shield to right side of tractor.
- Lower lift lever to its lowest position.
- Connect front links to mower deck and secure with retainer springs.
- Connect suspension arms to rear deck brackets and secure with retainer springs.
- Connect anti-swaybar to chassis bracket and secure with retainer spring.
- Push clutch cable housing guide into bracket, slide collar onto guide and secure with large retainer spring.
- Install belt onto engine pulley.

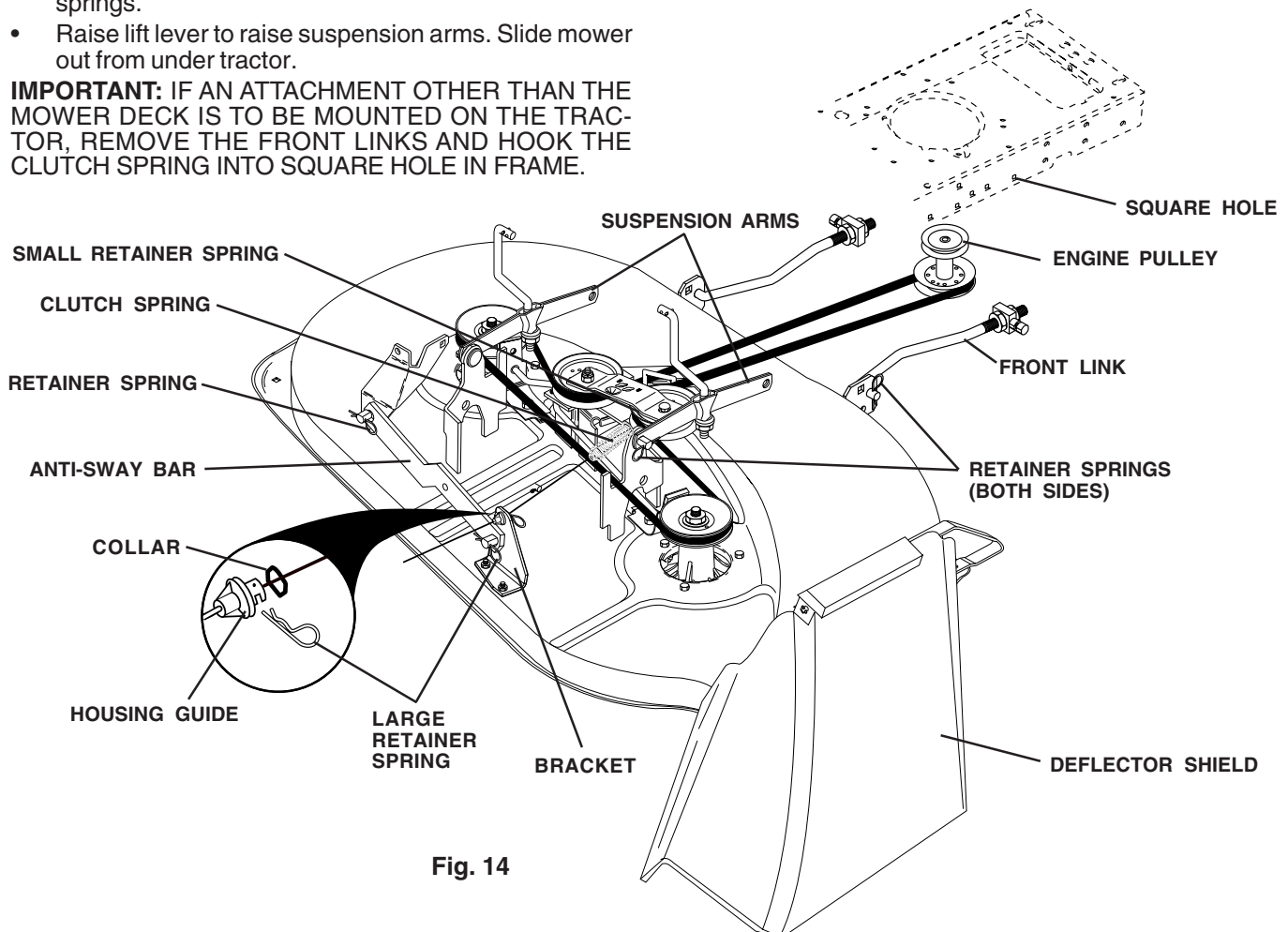

Fig. 14

# SERVICE AND ADJUSTMENTS

## TO LEVEL MOWER HOUSING

Adjust the mower while tractor is parked on level ground or driveway. Make sure tires are properly inflated (See "PRODUCT SPECIFICATIONS" section of this manual). If tires are over or underinflated, you will not properly adjust your mower.

**SIDE-TO-SIDE ADJUSTMENT** (See Figs. 15 and 16)

- Raise mower to its highest position.
- At the midpoint of both sides of mower, measure height from bottom edge of mower to ground. Distance "A" on both sides of mower should be the same or within 1/4" of each other.
- If adjustment is necessary, make adjustment on one side of mower only.
- To raise one side of mower, tighten lift link adjustment nut on that side.
- To lower one side of mower, loosen lift link adjustment nut on that side.

**NOTE:** Three full turns of adjustment nut will change mower height about 1/8".

- Recheck measurements after adjusting.

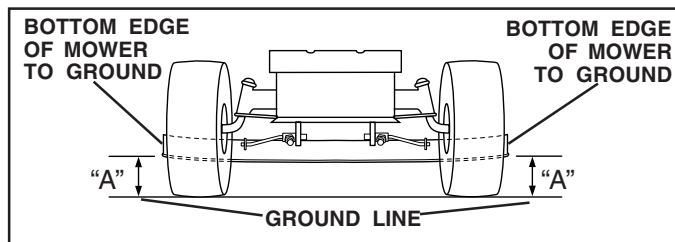

FIG. 15

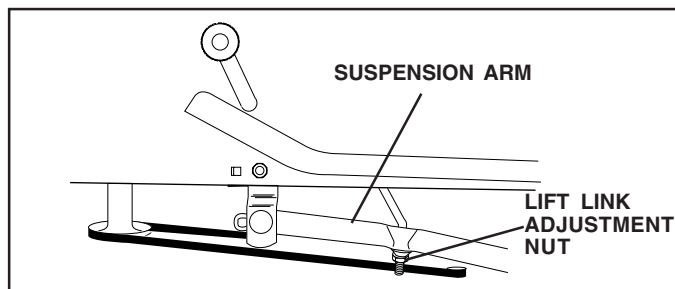

FIG. 16

**FRONT-TO-BACK ADJUSTMENT** (See Figs. 17 and 18)

**IMPORTANT:** DECK MUST BE LEVEL SIDE-TO-SIDE. IF THE FOLLOWING FRONT-TO-BACK ADJUSTMENT IS NECESSARY, BE SURE TO ADJUST BOTH FRONT LINKS EQUALLY SO MOWER WILL STAY LEVEL SIDE-TO-SIDE.

To obtain the best cutting results, the mower housing should be adjusted so that the front is approximately 1/8" to 1/2" lower than the rear when the mower is in its highest position.

Check adjustment on right side of tractor. Measure distance "D" directly in front and behind the mandrel at bottom edge of mower housing as shown.

- Before making any necessary adjustments, check that both front links are equal in length.
- If links are not equal in length, adjust one link to same length as other link.
- To lower front of mower loosen nut "E" on both front links an equal number of turns.

- When distance "D" is 1/8" to 1/2" lower at front than rear, tighten nuts "F" against trunnion on both front links.
- To raise front of mower, loosen nut "F" from trunnion on both front links. Tighten nut "E" on both front links an equal number of turns.
- When distance "D" is 1/8" to 1/2" lower at front than rear, tighten nut "F" against trunnion on both front links.
- Recheck side-to-side adjustment.

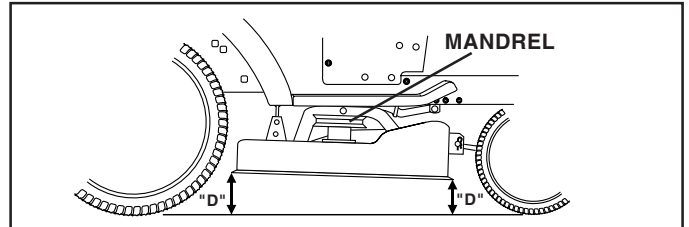

FIG. 17

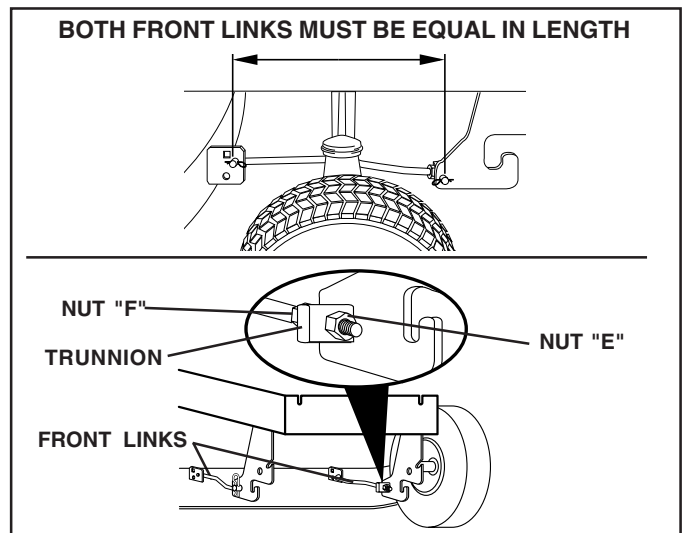

FIG. 18

## TO REPLACE MOWER BLADE DRIVE BELT (See Fig. 19)

The mower blade drive belt may be replaced without tools. Park the tractor on level surface. Engage parking brake.

### BELT REMOVAL -

- Place attachment clutch in "DISENGAGED" position.
- Move attachment lift lever forward to lower mower to its lowest position.
- Roll belt off engine pulley.
- Disconnect R.H. suspension arm from rear deck bracket by removing retainer spring.
- Work belt off both mandrel pulleys and idler pulleys.
- Pull belt away from mower.

### BELT INSTALLATION -

- Work new belt around both mandrel pulleys and idler pulleys.
- Install new belt into engine pulley groove.
- Reconnect R.H. suspension arm and secure with retainer spring.
- Make sure belt is in all pulley grooves and inside all belt guides.

# SERVICE AND ADJUSTMENTS

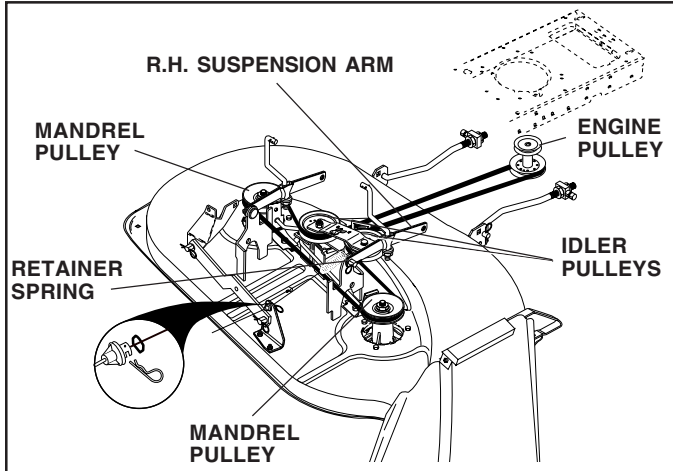

FIG. 19

- Pull belt toward front of tractor and remove downwards from around engine pulley.
- Install new belt by reversing above procedure.

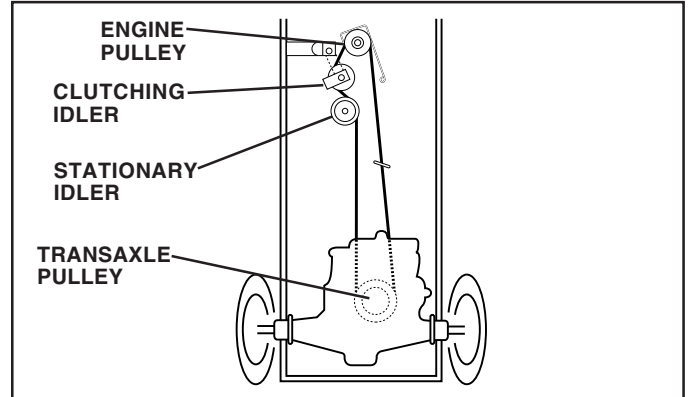

FIG. 21

## TO ADJUST BRAKE (See Fig. 20)

Your tractor is equipped with an adjustable brake system which is mounted on the right side of the transaxle.

If tractor requires more than six (6) feet stopping distance at high speed in highest gear on a level dry concrete or paved surface, then brake must be adjusted.

- Depress clutch/brake pedal and engage parking brake.
- Measure distance between brake operating arm and nut "A" on brake rod.
- If distance is other than 1-1/2", loosen jam nut and turn nut "A" until distance becomes 1-1/2". Retighten jam nut against nut "A".
- Road test tractor for proper stopping distance as stated above. Readjust if necessary. If stopping distance is still greater than six (6) feet in highest gear, further maintenance is necessary. Contact your nearest authorized service center/department.

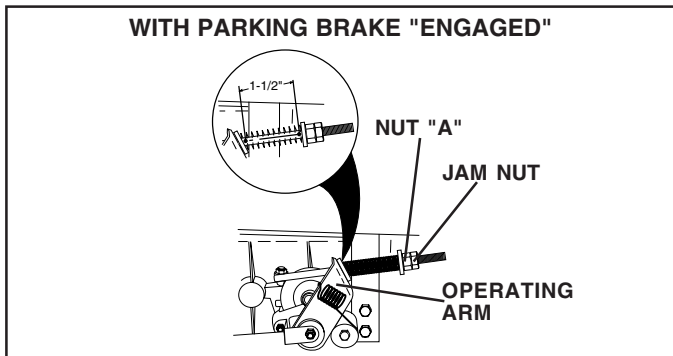

FIG. 20

## TO REPLACE MOTION DRIVE BELT (See Fig. 21)

Park the tractor on level surface. Engage parking brake. For assistance, there is a belt installation guide decal on bottom side of left footrest.

- Remove mower (See "TO REMOVE MOWER" in this section of this manual.)
- Remove belt from stationary idler and clutching idler.
- Pull belt slack toward rear of tractor. Remove belt upwards from transaxle pulley by deflecting belt keepers.

## TO ADJUST STEERING WHEEL ALIGNMENT

If steering wheel crossbars are not horizontal (left to right) when wheels are positioned straight forward, remove steering wheel and reassemble per instructions in the Assembly section of this manual.

## FRONT WHEEL TOE-IN/CAMBER

The front wheel toe-in and camber are not adjustable on your tractor. If damage has occurred to affect the front wheel toe-in or camber, contact your nearest authorized service center/department.

## TO REMOVE WHEEL FOR REPAIRS (See Fig. 22)

- Block up axle securely.
- Remove axle cover, retaining ring and washers to allow wheel removal (rear wheel contains a square key - Do not lose).
- Repair tire and reassemble.
- On rear wheels only: align grooves in rear wheel hub and axle. Insert square key.
- Replace washers and snap retaining ring securely in axle groove.
- Replace axle cover.

**NOTE:** To seal tire punctures and prevent flat tires due to slow leaks, tire sealant may be purchased from your local parts dealer. Tire sealant also prevents tire dry rot and corrosion.

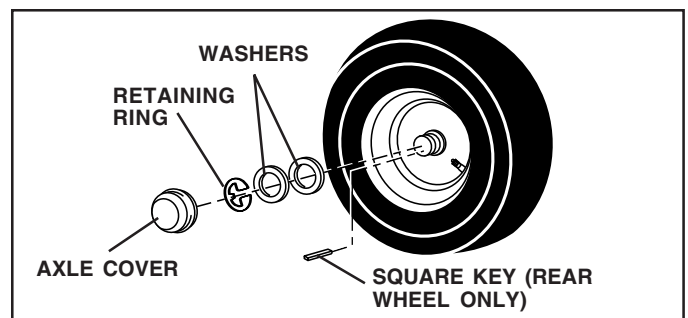

FIG. 22

# SERVICE AND ADJUSTMENTS

## TO START ENGINE WITH A WEAK BATTERY (See Fig. 23)



**CAUTION:** Lead-acid batteries generate explosive gases. Keep sparks, flame and smoking materials away from batteries. Always wear eye protection when around batteries.

If your battery is too weak to start the engine, it should be recharged. (See "BATTERY" in the Customer Responsibilities section of this manual).

If "jumper cables" are used for emergency starting, follow this procedure:

**IMPORTANT:** YOUR TRACTOR IS EQUIPPED WITH A 12 VOLT NEGATIVE GROUNDED SYSTEM. THE OTHER VEHICLE MUST ALSO BE A 12 VOLT NEGATIVE GROUNDED SYSTEM. DO NOT USE YOUR TRACTOR BATTERY TO START OTHER VEHICLES.

### TO ATTACH JUMPER CABLES -

- Connect each end of the RED cable to the POSITIVE (+) terminal of each battery, taking care not to short against chassis.
- Connect one end of the BLACK cable to the NEGATIVE (-) terminal of fully charged battery.
- Connect the other end of the BLACK cable to good CHASSIS GROUND, away from fuel tank and battery.

### TO REMOVE CABLES, REVERSE ORDER -

- BLACK cable first from chassis and then from the fully charged battery.
- RED cable last from both batteries.

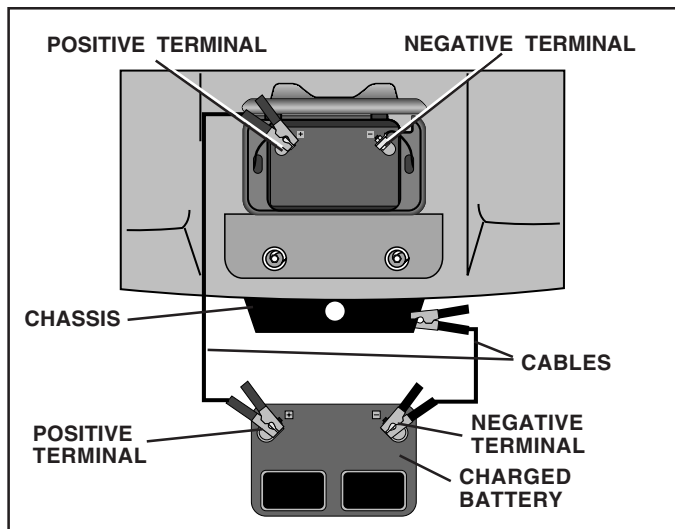

FIG. 23

## REPLACING BATTERY (See Figs. 24 and 25)



**CAUTION:** Do not short battery terminals by allowing a wrench or any other object to contact both terminals at the same time. Before connecting battery, remove metal bracelets, wristwatch bands, rings, etc. Positive terminal must be connected first to prevent sparking from accidental grounding.

- Lift seat pan to raised position.
- Disconnect BLACK battery cable first then RED battery cable and carefully remove battery from tractor.
- Install new battery with terminals in same position as old battery.
- First connect RED battery cable to positive (+) terminal with hex bolt and keps nut as shown. Tighten securely. Slide terminal cover over terminal.
- Connect BLACK grounding cable to negative (-) terminal with remaining hex bolt and keps nut. Tighten securely.

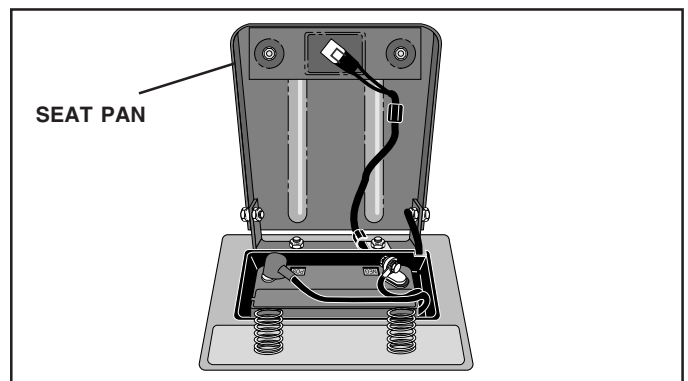

FIG. 24

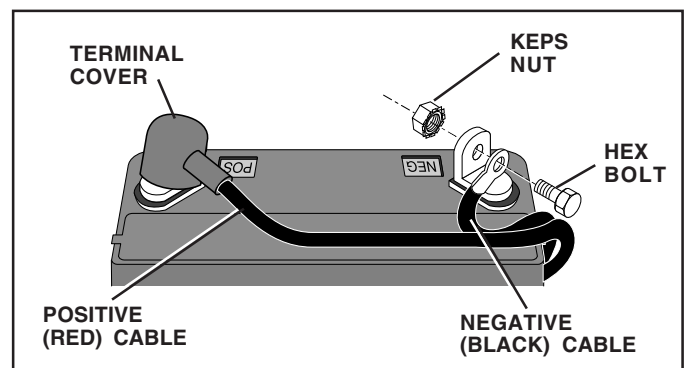

FIG. 25

# SERVICE AND ADJUSTMENTS

## TO REPLACE HEADLIGHT BULB

- Raise hood.
- Pull bulb holder out of the hole in the backside of the grill.
- Replace bulb in holder and push bulb holder securely back into the hole in the backside of the grill.
- Close hood.

## INTERLOCKS AND RELAYS

Loose or damaged wiring may cause your tractor to run poorly, stop running, or prevent it from starting.

- Check wiring. See electrical wiring diagram in the Repair Parts section.

## TO REPLACE FUSE

Replace with 20 amp automotive-type plug-in fuse. The fuse holder is located behind the dash.

## TO REMOVE HOOD AND GRILL ASSEMBLY (See Fig. 26)

- Raise hood.
- Unsnap headlight wire connector.
- Stand in front of tractor. Grasp hood at sides, tilt toward engine and lift off of tractor.
- To replace, reverse above procedure.

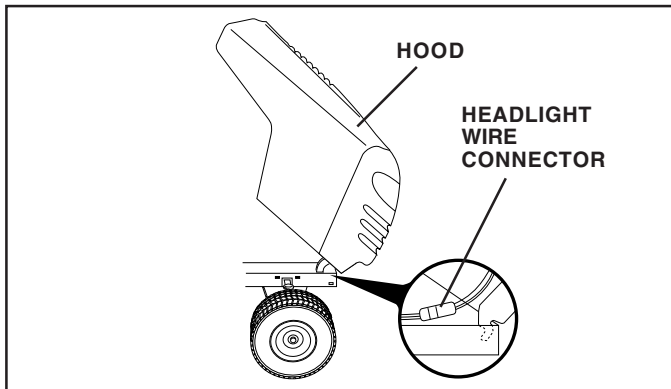

FIG. 26

## ENGINE

### TO ADJUST THROTTLE CONTROL CABLE (See Fig. 27)

The throttle control has been preset at the factory and adjustment should not be necessary. Check adjustment as described below before loosening cable. If adjustment is necessary, proceed as follows:

- With engine not running, move throttle control lever from slow to choke position. Slowly move lever from choke to fast position.
- Check that holes "A" in governor control lever and hole in governor plate line-up. If holes "A" are not aligned, loosen clamp screw and move throttle cable until holes are aligned. Tighten clamp screw securely.

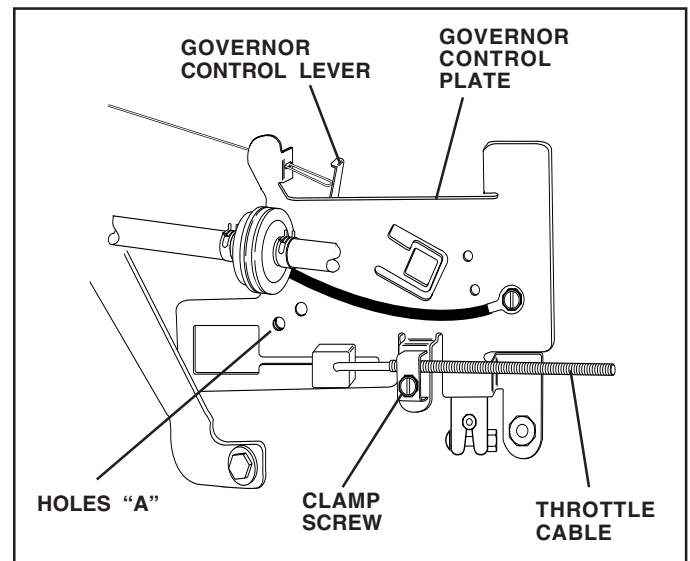

FIG. 27

### TO ADJUST CARBURETOR

The carburetor has been preset at the factory and adjustment should not be necessary. However, minor adjustment may be required to compensate for differences in fuel, temperature, altitude or load. If the carburetor does need adjustment, see engine manual.

High speed stop is factory adjusted. Do not adjust - damage may result.

**IMPORTANT:** NEVER TAMPER WITH THE ENGINE GOVERNOR, WHICH IS FACTORY SET FOR PROPER ENGINE SPEED. OVERSPEEDING THE ENGINE ABOVE THE FACTORY HIGH SPEED SETTING CAN BE DANGEROUS. IF YOU THINK THE ENGINE-GOVERNED HIGH SPEED NEEDS ADJUSTING, CONTACT YOUR NEAREST AUTHORIZED SERVICE CENTER/DEPARTMENT, WHICH HAS PROPER EQUIPMENT AND EXPERIENCE TO MAKE ANY NECESSARY ADJUSTMENTS.

# STORAGE

Immediately prepare your tractor for storage at the end of the season or if the tractor will not be used for 30 days or more.



**CAUTION:** Never store the tractor with gasoline in the tank inside a building where fumes may reach an open flame or spark. Allow the engine to cool before storing in any enclosure.

## TRACTOR

Remove mower from tractor for winter storage. When mower is to be stored for a period of time, clean it thoroughly, remove all dirt, grease, leaves, etc. Store in a clean, dry area.

- Clean entire tractor (See “CLEANING” in the Customer Responsibilities section of this manual).
- Inspect and replace belts, if necessary (See belt replacement instructions in the Service and Adjustments section of this manual).
- Lubricate as shown in the Customer Responsibilities section of this manual.
- Be sure that all nuts, bolts and screws are securely fastened. Inspect moving parts for damage, breakage and wear. Replace if necessary.
- Touch up all rusted or chipped paint surfaces; sand lightly before painting.

## BATTERY

- Fully charge the battery for storage.
- After a period of time in storage, battery may require recharging.
- To help prevent corrosion and power leakage during long periods of storage, battery cables should be disconnected and battery cleaned thoroughly (see “TO CLEAN BATTERY AND TERMINALS” in the Customer Responsibilities section of this manual).
- After cleaning, leave cables disconnected and place cables where they cannot come in contact with battery terminals.
- If battery is removed from tractor for storage, do not store battery directly on concrete or damp surfaces.

## ENGINE

### FUEL SYSTEM

**IMPORTANT:** IT IS IMPORTANT TO PREVENT GUM DEPOSITS FROM FORMING IN ESSENTIAL FUEL SYSTEM PARTS SUCH AS CARBURETOR, FUEL FILTER, FUEL HOSE, OR TANK DURING STORAGE. ALSO, EXPERIENCE INDICATES THAT ALCOHOL BLENDED FUELS (CALLED GASOHOL OR USING ETHANOL OR METHANOL) CAN ATTRACT MOISTURE WHICH LEADS TO SEPARATION AND FORMATION OF ACIDS DURING STORAGE. ACIDIC GAS CAN DAMAGE THE FUEL SYSTEM OF AN ENGINE WHILE IN STORAGE.

- Drain the fuel tank.
- Start the engine and let it run until the fuel lines and carburetor are empty.
- Never use engine or carburetor cleaner products in the fuel tank or permanent damage may occur.
- Use fresh fuel next season.

**NOTE:** Fuel stabilizer is an acceptable alternative in minimizing the formation of fuel gum deposits during storage. Add stabilizer to gasoline in fuel tank or storage container. Always follow the mix ratio found on stabilizer container. Run engine at least 10 minutes after adding stabilizer to allow the stabilizer to reach the carburetor. Do not drain the gas tank and carburetor if using fuel stabilizer.

### ENGINE OIL

Drain oil (with engine warm) and replace with clean engine oil. (See “ENGINE” in the Customer Responsibilities section of this manual).

### CYLINDER(S)

- Remove spark plug(s).
- Pour one ounce of oil through spark plug hole(s) into cylinder(s).
- Turn ignition key to “START” position for a few seconds to distribute oil.
- Replace with new spark plug(s).

### OTHER

- Do not store gasoline from one season to another.
- Replace your gasoline can if your can starts to rust. Rust and/or dirt in your gasoline will cause problems.
- If possible, store your tractor indoors and cover it to give protection from dust and dirt.
- Cover your tractor with a suitable protective cover that does not retain moisture. Do not use plastic. Plastic cannot breathe which allows condensation to form and will cause your tractor to rust.

**IMPORTANT:** NEVER COVER TRACTOR WHILE ENGINE AND EXHAUST AREAS ARE STILL WARM.



# TROUBLESHOOTING POINTS

PROBLEM	CAUSE	CORRECTION
<b>Will not start</b>	<ol style="list-style-type: none"> <li>1. Out of fuel.</li> <li>2. Engine not "CHOKED" properly.</li> <li>3. Engine flooded.</li> <li>4. Bad spark plug.</li> <li>5. Dirty air filter.</li> <li>6. Dirty fuel filter.</li> <li>7. Water in fuel.</li> <li>8. Loose or damaged wiring.</li> <li>9. Carburetor out of adjustment.</li> <li>10. Engine valves out of adjustment.</li> </ol>	<ol style="list-style-type: none"> <li>1. Fill fuel tank.</li> <li>2. See "TO START ENGINE" in Operation section.</li> <li>3. Wait several minutes before attempting to start.</li> <li>4. Replace spark plug.</li> <li>5. Clean/replace air filter.</li> <li>6. Replace fuel filter.</li> <li>7. Drain fuel tank and carburetor, refill tank with fresh gasoline and replace fuel filter.</li> <li>8. Check all wiring.</li> <li>9. See "To Adjust Carburetor" in Service Adjustments section.</li> <li>10. Contact an authorized service center/department.</li> </ol>
<b>Hard to start</b>	<ol style="list-style-type: none"> <li>1. Dirty air filter.</li> <li>2. Bad spark plug.</li> <li>3. Weak or dead battery.</li> <li>4. Dirty fuel filter.</li> <li>5. Stale or dirty fuel.</li> <li>6. Loose or damaged wiring.</li> <li>7. Carburetor out of adjustment.</li> <li>8. Engine valves out of adjustment.</li> </ol>	<ol style="list-style-type: none"> <li>1. Clean/replace air filter.</li> <li>2. Replace spark plug.</li> <li>3. Recharge or replace battery.</li> <li>4. Replace fuel filter.</li> <li>5. Drain fuel tank and refill with fresh gasoline.</li> <li>6. Check all wiring.</li> <li>7. See "To Adjust Carburetor" in Service Adjustments section.</li> <li>8. Contact an authorized service center/department.</li> </ol>
<b>Engine will not turn over</b>	<ol style="list-style-type: none"> <li>1. Clutch/brake pedal not depressed.</li> <li>2. Attachment clutch is engaged.</li> <li>3. Weak or dead battery.</li> <li>4. Blown fuse.</li> <li>5. Corroded battery terminals.</li> <li>6. Loose or damaged wiring.</li> <li>7. Faulty ignition switch.</li> <li>8. Faulty solenoid or starter.</li> <li>9. Faulty operator presence switch(es).</li> </ol>	<ol style="list-style-type: none"> <li>1. Depress clutch/brake pedal.</li> <li>2. Disengage attachment clutch.</li> <li>3. Recharge or replace battery.</li> <li>4. Replace fuse.</li> <li>5. Clean battery terminals.</li> <li>6. Check all wiring.</li> <li>7. Check/replace ignition switch.</li> <li>8. Check/replace solenoid or starter.</li> <li>9. Contact an authorized service center/department.</li> </ol>
<b>Engine clicks but will not start</b>	<ol style="list-style-type: none"> <li>1. Weak or dead battery.</li> <li>2. Corroded battery terminals.</li> <li>3. Loose or damaged wiring.</li> <li>4. Faulty solenoid or starter.</li> </ol>	<ol style="list-style-type: none"> <li>1. Recharge or replace battery.</li> <li>2. Clean battery terminals.</li> <li>3. Check all wiring.</li> <li>4. Check/replace solenoid or starter.</li> </ol>
<b>Loss of power</b>	<ol style="list-style-type: none"> <li>1. Cutting too much grass/too fast.</li> <li>2. Throttle in "CHOKE" position.</li> <li>3. Build-up of grass, leaves and trash under mower.</li> <li>4. Dirty air filter.</li> <li>5. Low oil level/dirty oil.</li> <li>6. Faulty spark plug.</li> <li>7. Dirty fuel filter.</li> <li>8. Stale or dirty fuel.</li> <li>9. Water in fuel.</li> <li>10. Spark plug wire loose.</li> <li>11. Dirty engine air screen/fins.</li> <li>12. Dirty/clogged muffler.</li> <li>13. Loose or damaged wiring.</li> <li>14. Carburetor out of adjustment.</li> <li>15. Engine valves out of adjustment.</li> </ol>	<ol style="list-style-type: none"> <li>1. Set in "Higher Cut" position/reduce speed.</li> <li>2. Adjust throttle control.</li> <li>3. Clean underside of mower housing.</li> <li>4. Clean/replace air filter.</li> <li>5. Check oil level/change oil.</li> <li>6. Clean and regap or change spark plug.</li> <li>7. Replace fuel filter.</li> <li>8. Drain fuel tank and refill with fresh gasoline.</li> <li>9. Drain fuel tank and carburetor, refill tank with fresh gasoline and replace fuel filter.</li> <li>10. Connect and tighten spark plug wire.</li> <li>11. Clean engine air screen/fins.</li> <li>12. Clean/replace muffler.</li> <li>13. Check all wiring.</li> <li>14. See "To Adjust Carburetor" in Service Adjustments section.</li> <li>15. Contact an authorized service center/department.</li> </ol>
<b>Excessive vibration</b>	<ol style="list-style-type: none"> <li>1. Worn, bent or loose blade.</li> <li>2. Bent blade mandrel.</li> <li>3. Loose/damaged part(s).</li> </ol>	<ol style="list-style-type: none"> <li>1. Replace blade. Tighten blade bolt.</li> <li>2. Replace blade mandrel.</li> <li>3. Tighten loose part(s). Replace damaged parts.</li> </ol>

# TROUBLESHOOTING POINTS

PROBLEM	CAUSE	CORRECTION
<b>Engine continues to run when operator leaves seat with attachment clutch engaged</b>	<ol style="list-style-type: none"> <li>1. Faulty operator-safety presence control system.</li> </ol>	<ol style="list-style-type: none"> <li>1. Check wiring, switches and connections. If not corrected, contact an authorized service center/ department.</li> </ol>
<b>Poor cut - uneven</b>	<ol style="list-style-type: none"> <li>1. Worn, bent or loose blade.</li> <li>2. Mower deck not level.</li> <li>3. Buildup of grass, leaves, and trash under mower.</li> <li>4. Bent blade mandrel.</li> <li>5. Clogged mower deck vent holes from buildup of grass, leaves, and trash around mandrels.</li> </ol>	<ol style="list-style-type: none"> <li>1. Replace blade. Tighten blade bolt.</li> <li>2. Level mower deck.</li> <li>3. Clean underside of mower housing.</li> <li>4. Replace blade mandrel.</li> <li>5. Clean around mandrels to open vent holes.</li> </ol>
<b>Mower blades will not rotate</b>	<ol style="list-style-type: none"> <li>1. Obstruction in clutch mechanism.</li> <li>2. Worn/damaged mower drive belt.</li> <li>3. Frozen idler pulley.</li> <li>4. Frozen blade mandrel.</li> </ol>	<ol style="list-style-type: none"> <li>1. Remove obstruction.</li> <li>2. Replace mower drive belt.</li> <li>3. Replace idler pulley.</li> <li>4. Replace blade mandrel.</li> </ol>
<b>Poor grass discharge</b>	<ol style="list-style-type: none"> <li>1. Engine speed too slow.</li> <li>2. Travel speed too fast.</li> <li>3. Wet grass.</li> <li>4. Mower deck not level.</li> <li>5. Low/uneven tire air pressure.</li> <li>6. Worn, bent or loose blade.</li> <li>7. Buildup of grass, leaves and trash under mower.</li> <li>8. Mower drive belt worn.</li> <li>9. Blades improperly installed.</li> <li>10. Improper blades used.</li> <li>11. Clogged mower deck vent holes from buildup of grass, leaves, and trash around mandrels.</li> </ol>	<ol style="list-style-type: none"> <li>1. Place throttle control in "FAST" position.</li> <li>2. Shift to slower speed.</li> <li>3. Allow grass to dry before mowing.</li> <li>4. Level mower deck.</li> <li>5. Check tires for proper air pressure.</li> <li>6. Replace/sharpen blade. Tighten blade bolt.</li> <li>7. Clean underside of mower housing.</li> <li>8. Replace mower drive belt.</li> <li>9. Reinstall blades sharp edge down.</li> <li>10. Replace with blades listed in this manual.</li> <li>11. Clean around mandrels to open vent holes.</li> </ol>
<b>Headlight(s) not working (if so equipped)</b>	<ol style="list-style-type: none"> <li>1. Switch is "OFF".</li> <li>2. Bulb(s) or lamp(s) burned out.</li> <li>3. Faulty light switch.</li> <li>4. Loose or damaged wiring.</li> <li>5. Blown fuse.</li> </ol>	<ol style="list-style-type: none"> <li>1. Turn switch "ON".</li> <li>2. Replace bulb(s) or lamp(s).</li> <li>3. Check/replace light switch.</li> <li>4. Check wiring and connections.</li> <li>5. Replace fuse.</li> </ol>
<b>Battery will not charge</b>	<ol style="list-style-type: none"> <li>1. Bad battery cell(s).</li> <li>2. Poor cable connections.</li> <li>3. Faulty regulator (if so equipped).</li> <li>4. Faulty alternator.</li> </ol>	<ol style="list-style-type: none"> <li>1. Replace battery.</li> <li>2. Check/clean all connections.</li> <li>3. Replace regulator.</li> <li>4. Replace alternator.</li> </ol>
<b>Engine "backfires" when turning engine "OFF"</b>	<ol style="list-style-type: none"> <li>1. Engine throttle control not set at "SLOW" position for 30 seconds before stopping engine.</li> </ol>	<ol style="list-style-type: none"> <li>1. Move throttle control to "SLOW" position and allow to idle for 30 seconds before stopping engine.</li> </ol>

**TRACTOR - - MODEL NUMBER WE12538K, PRODUCT NO. 954 56 29-06  
SCHEMATIC**

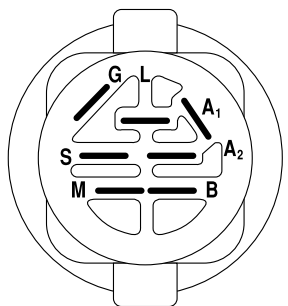
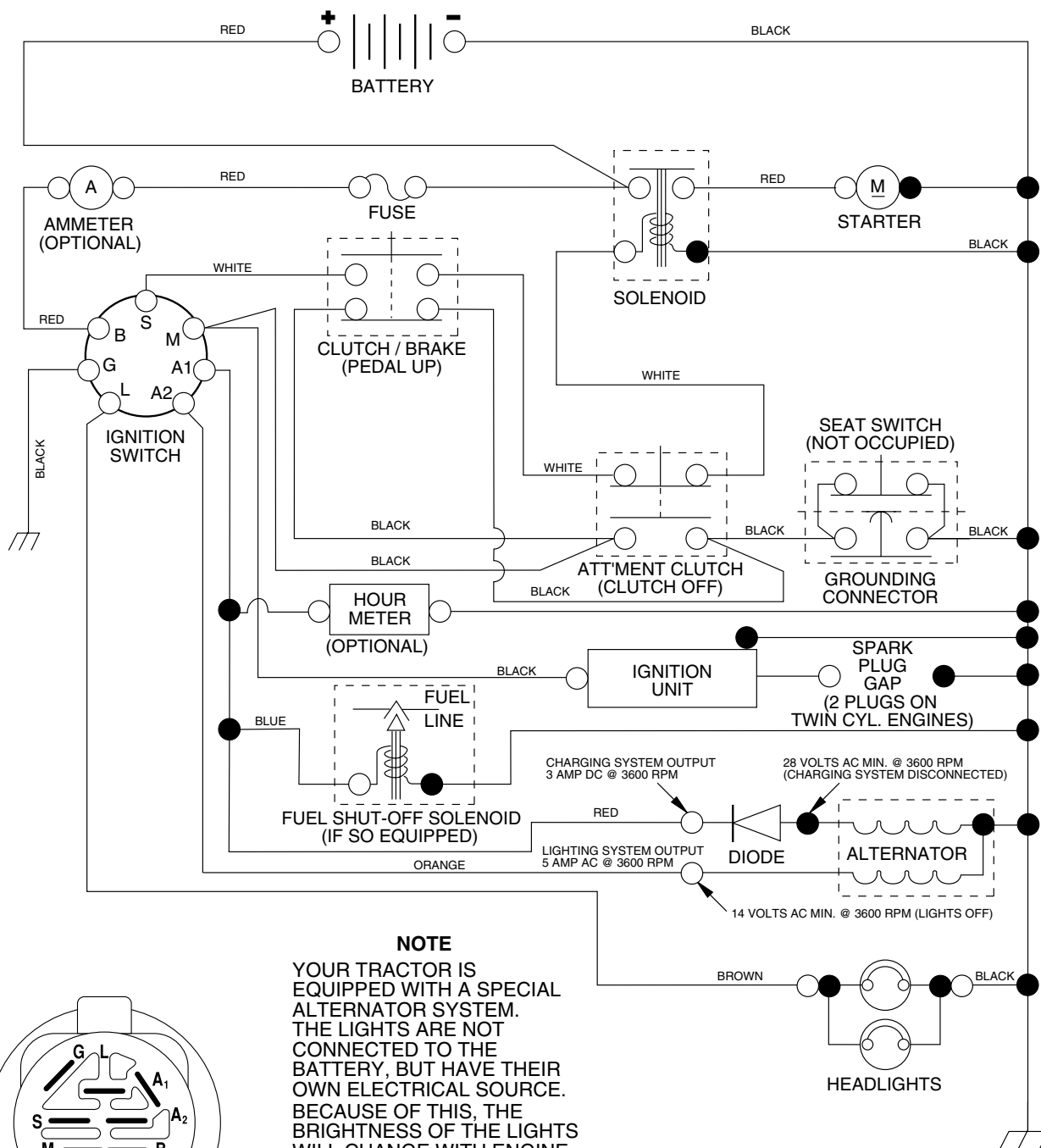

**IGNITION SWITCH**

POSITION	CIRCUIT	"MAKE"
OFF	M+G+A1	NONE
RUN/LIGHT	B+A1	A2+L
RUN	B+A1	NONE
START	B + S + A1	NONE

**NOTE**  
YOUR TRACTOR IS EQUIPPED WITH A SPECIAL ALTERNATOR SYSTEM. THE LIGHTS ARE NOT CONNECTED TO THE BATTERY, BUT HAVE THEIR OWN ELECTRICAL SOURCE. BECAUSE OF THIS, THE BRIGHTNESS OF THE LIGHTS WILL CHANGE WITH ENGINE SPEED. AT IDLE THE LIGHTS WILL DIM. AS THE ENGINE IS SPEEDED UP, THE LIGHTS WILL BECOME THEIR BRIGHTEST.

**WIRING INSULATED CLIPS**

**NOTE:** IF WIRING INSULATED CLIPS WERE REMOVED FOR SERVICING OF UNIT, THEY SHOULD BE REPLACED TO PROPERLY SECURE YOUR WIRING.

**NON-REMOVABLE CONNECTIONS**

**REMOVABLE CONNECTIONS**

# REPAIR PARTS

TRACTOR - - MODEL NUMBER WE12538K, PRODUCT NO. 954 56 29-06  
ELECTRICAL

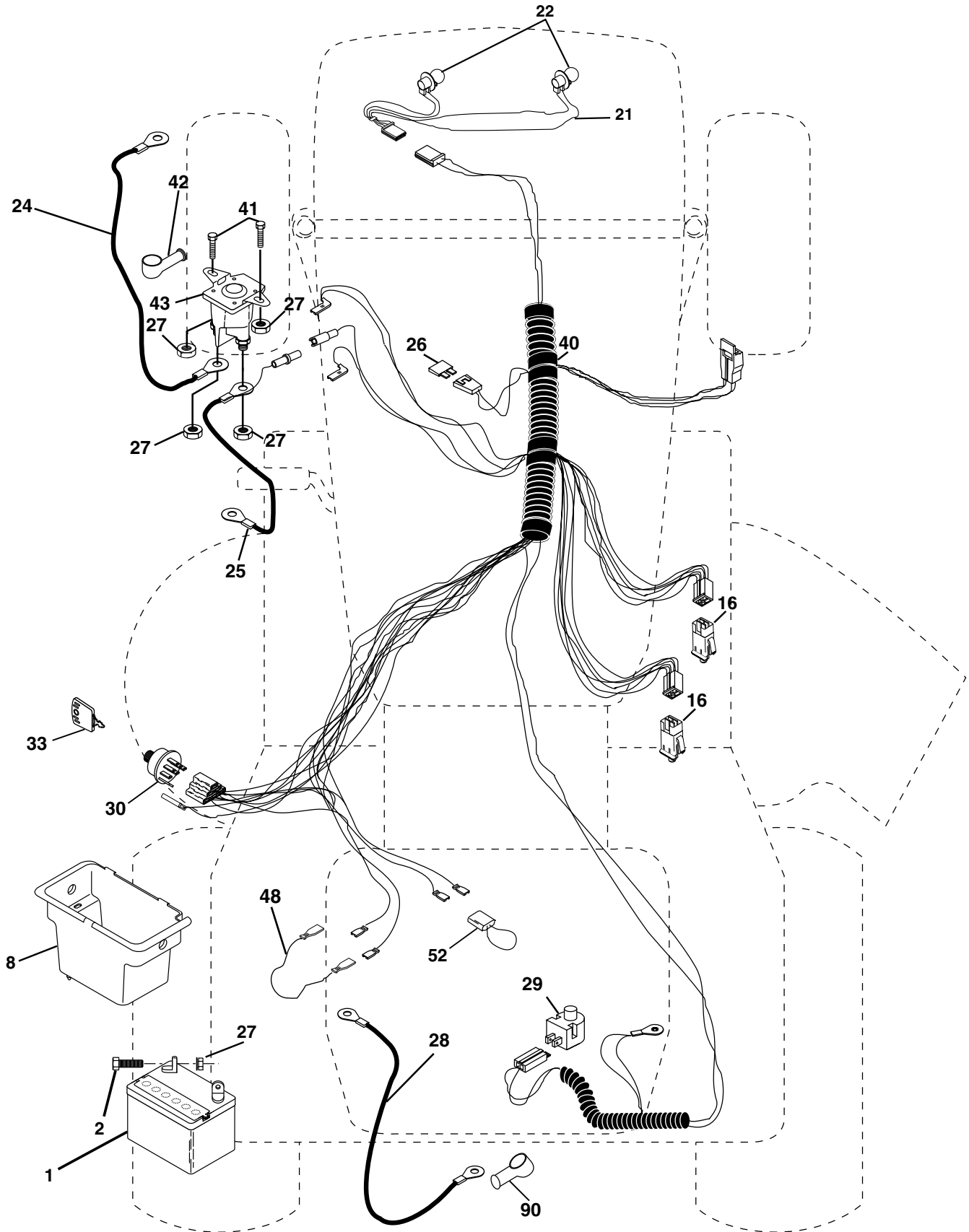

## REPAIR PARTS

TRACTOR - - MODEL NUMBER WE12538K, PRODUCT NO. 954 56 29-06  
ELECTRICAL

KEY NO.	PART NO.	DESCRIPTION
1	163465	Battery
2	74760412	Bolt Hex Hd 1/4-20unc X 3/4
8	176689	Box Battery
16	176138	Switch Interlock
21	175685	Harness Asm Light W/4152j
22	4152J	Bulb Light #1156
24	4799J	Cable Battery 6 Ga 11"red
25	146147	Cable Battery
26	175158	Fuse 20 AMP
27	73510400	Nut Keps Hex 1/4-20 Unc
28	4207J	Cable Ground 6 Ga 12"black
29	121305X	Switch Plunger Nc Gray
30	175566	Switch Ign
33	140401	Key Ign
40	179720	Harness Ign
41	71110408	Bolt Blk Fin Hex 1/4-20
42	131563	Cover Terminal Red
43	178861	Solenoid
48	140844	Adapter Ammeter
52	141940	Protection Wire Loop
90	180449	Cover Terminal Battery

**NOTE:** All component dimensions given in U. S. inches 1 inch = 25.4 mm.

# REPAIR PARTS

TRACTOR - - MODEL NUMBER WE12538K, PRODUCT NO. 954 56 29-06  
CHASSIS

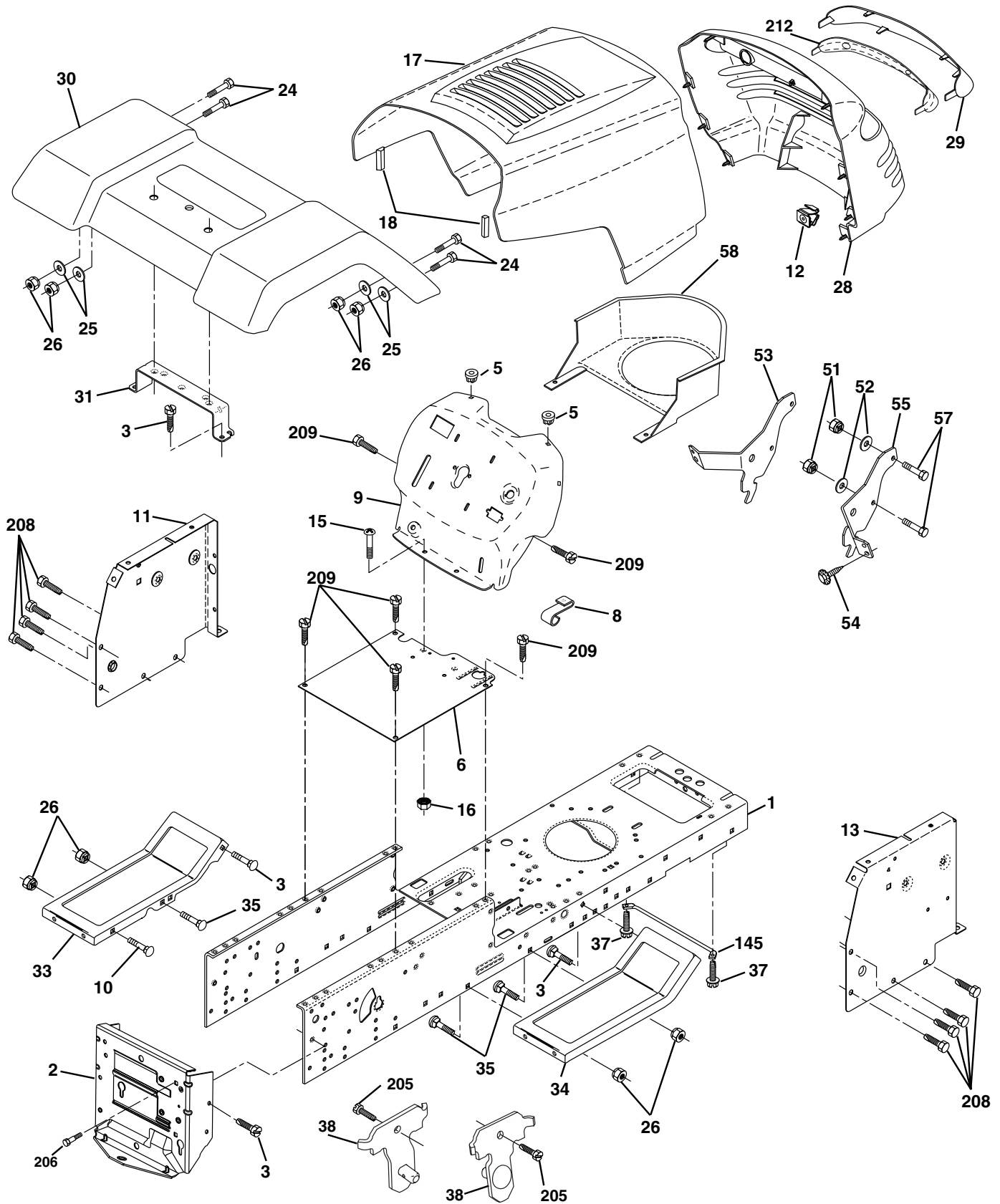

**REPAIR PARTS****TRACTOR - - MODEL NUMBER WE12538K, PRODUCT NO. 954 56 29-06  
CHASSIS**

<b>KEY NO.</b>	<b>PART NO.</b>	<b>DESCRIPTION</b>
1	174620	Chassis
2	176554	Drawbar, Stretch
3	17060612	Screw 3/8-16 x 3/4
5	155272	Bumper, Hood/Dash
6	174643X013	Saddle Silkscreen Flt Sdl
8	155138	Clip Retainer Slide-On
9	168347X011	Dash
10	72140608	Bolt, Carriage 3/8-16 x 1
11	174996	Panel Dash LH
12	145660	Clip Tinnerman Grille P.L
13	172105X010	Panel Silkscr Dash RH
15	74180512	Screw Mach TRHD 5/16-18uncx3/4
16	73510500	Nut Keps 5/16-18 Unc
17	159639x550	Hood
18	126938X	BumperHood
24	74780616	Bolt Fin Hex 3/8-16unc X 1 Gr. 5
25	19131312	Washer 13/32 X 13/16 X 12 Ga
26	73800600	Nut Lock Hex w/Ins 3/8-16 Unc
28	179101	Grille/Lens Asm
29	140273X599	Lens Grille Private Label
30	169465X550	Fender
31	136619	Bracket Fender Repl 109873x
33	179716X550	Footrest Pnt LH
34	179717X550	Footrest Pnt RH
35	72110606	Bolt Rdhd Sht Sqnk 3/8-16 X3/4
37	17490508	Screw Thdrol 5/16-18 x 1/2 TYT
38	175710	Bracket Asm. Pivot Mower Rear
51	73800400	Nut Lock W/Insert 1/4-20unc
52	19091416	Washer 9/32 x 7/8x16 Ga.
53	144697	Bracket Grille Lh
54	161464	Screw Hex 8-18 x 7/8
55	144696	Bracket Grille Rh
57	74780412	Bolt Fin Hex 1/4-20 unc x .75
58	150127	Duct Air Engine PL/LT
145	156524	Rod Pivot Chassis/Hood
205	17490608	Screw Thdrol 3/8-16 x 1/2
206	170165	Bolt Shoulder 5/16-18
208	17670608	Screw Thdrol 3/8-16 x 1/2
209	17000612	Screw Hex Wsh Thdrol 3/8-16
212	156229	Insert Lens Reflect
---	5479J	Plug Button Blk 359 Dia Choke

**NOTE:** All component dimensions given in U.S. inches  
1 inch = 25.4 mm.

# REPAIR PARTS

TRACTOR - - MODEL NUMBER WE12538K, PRODUCT NO. 954 56 29-06  
DRIVE

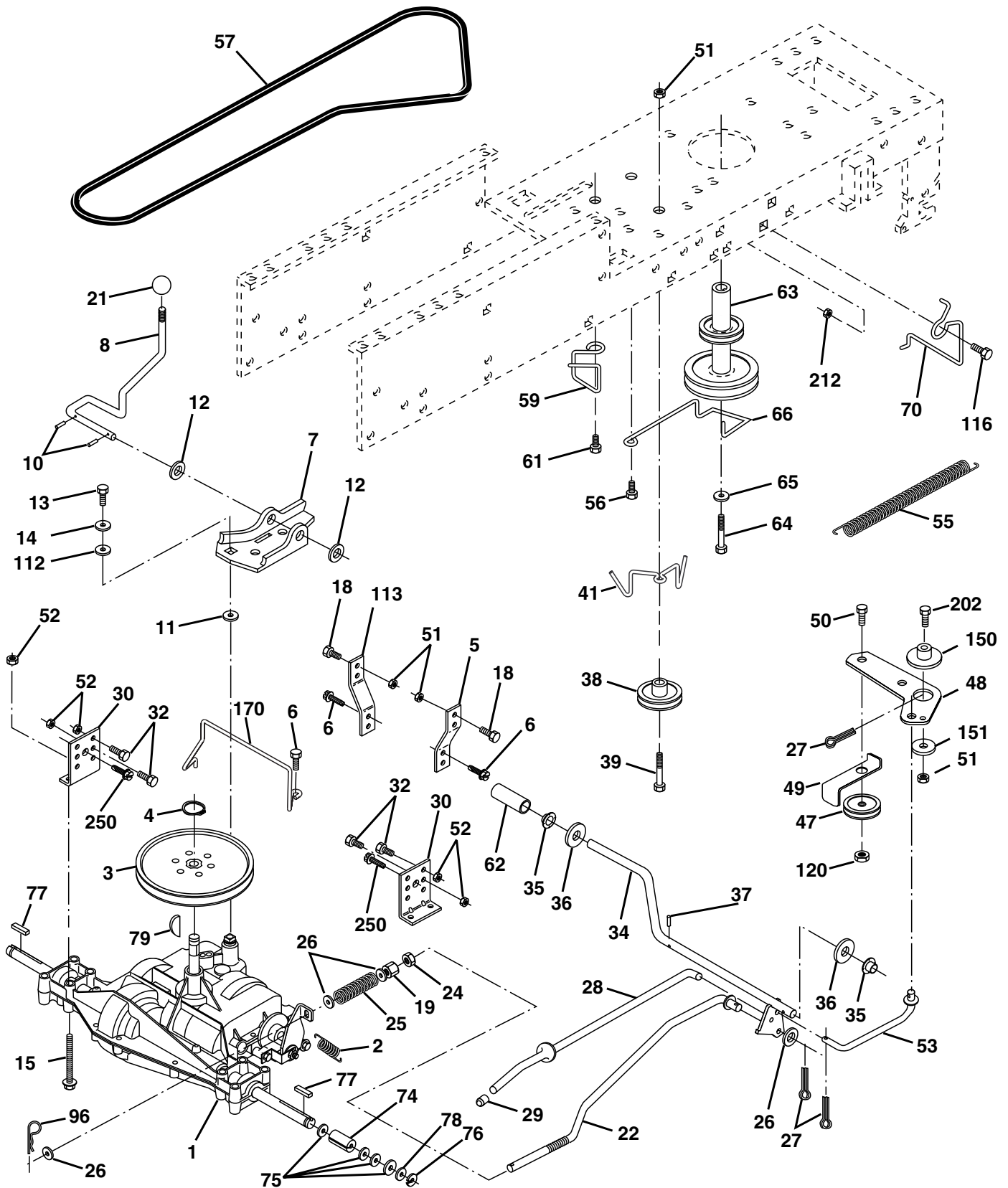



**REPAIR PARTS****TRACTOR - - MODEL NUMBER WE12538K, PRODUCT NO. 954 56 29-06  
DRIVE**

KEY NO.	PART NO.	DESCRIPTION	KEY NO.	PART NO.	DESCRIPTION
1	-----	Transaxle Peerless Model 205-544c (Order parts from transaxle manufacturer)	49	123205X	Retainer Belt Style Spring
2	146682	Spring Return Brake	50	74760624	Bolt Hex Hd 3/8-16unc X 1-1/2
3	123666X	Pulley Transaxle 18" tires	51	73680600	Nut Crownlock 3/8-16 Unc
4	12000028	Ring Retainer # 5100-62	52	73680500	Nut Crownlock 5/16-18 unc
5	121520X	Strap Torque 30 Degrees RH	53	105710X	Link Clutch 7 66
6	17060512	Screw 5/16-18 x 3/4	55	105709X	Spring Return Clutch 6 75
7	162240	Plate Rod Shift T/a	56	17060620	Screw 3/8-16 x 1-1/4
8	131679	Rod Shifter Blk	57	130801	V-Belt Ground Drive 95
10	76020416	Pin Cotter 1/8 X 1 Cad	59	169691	Keeper Belt Chassis Span Ctr
11	105701X	Washer Plate Shf 388 Sq Hole	61	17120614	Screw 3/8-16 x .875
12	19151216	Washer 15/32 X 3/4 X 16 Ga	62	8883R	Cover Pedal Blk Round
13	74550412	Bolt 1/4-28 unf Gr. 8 w/Patch	63	175410	Engine Pulley LT/YT
14	10040400	Washer Lock Hvy Helical 1/4	64	71170764	Bolt Hex 7/16-20x4 Gr 5
18	74780616	Bolt Fin Hex 3/8-16unc X 1 Gr. 5	65	10040700	Washer Lock Hvy Hlcl Spr 7/16
19	73800600	Nut lock Hex w/Ins 3/8-16 Unc	66	154778	Keeper Belt Engine
21	106933X	Knob Rd 1/2-13 Plstc Thds Blk	70	134683	Guide Belt Mower Drive RH
22	130804	Rod Brake LT	74	137057	Spacer Axle
24	73350600	Nut Hex Jam 3/8-16 Unc	75	121749X	Washer 25/32 X 1 1/4 X 16 Ga
25	106888X	Spring Rod Brake 2 00 Zinc	76	12000001	E-ring #5133-75
26	19131316	Washer 13/32 X 13/16 X 16 Ga	77	123583X	Key Square 2 0 X 1845/ 1865
27	76020412	Pin Cotter 1/8 X 3/4 Cad	78	121748X	Washer 25/32 X 1-5/8 X 16 Ga
28	175765	Rod Brake Parking LT/YT	79	2228M	Key Woodruff
29	71673	Cap Brake Parking Black	96	4497H	Retainer Spring 1"
30	174973	Bracket Transmission	112	19091210	Washer 9/32 X 3/4 X 10 Ga
32	74760512	Bolt Fin Hex 5/16-18 x 3/4	113	127285X	Strap Torque 90 Degrees LH
34	175578	Shaft Asm Pedal Foot Nibbed	116	72140608	Bolt Rdhd Sq Neck 3/8-16 x 1
35	120183X	Bearing Nylon Blk 629 Id	120	73900600	Nut Lock Flg 3/8-16
36	19211616	Washer 21/32 X 1 X 16 Ga	145	74490540	Bolt Hex Flg.Hd. 5/16-18 x Gr.5
37	1572H	Pin Roll 3/16 X 1"	150	175456	Spacer Retainer Lt
38	179114	Pulley Composite Flat	151	19133210	Washer 13/32 x 2 x 10 Ga.
39	74760648	Bolt Fin Hex 3/8-16 x 3	170	178394	Keeper, Belt Transaxle Gear
41	175556	Keeper Belt Idler	202	72110614	Bolt Carr Sh 3/8-16 x 1-3/4 Gr.5
47	127783	Pulley Idler V Groove Plastic	212	145212	Nut Hex Flg Lock
48	154407	Bellcrank Clutch Grnd Drv STL	250	17060612	Screw 3/8-16 x 3/4

**NOTE:** All component dimensions given in U.S. inches  
1 inch = 25.4 mm

# REPAIR PARTS

TRACTOR - - MODEL NUMBER WE12538K, PRODUCT NO. 954 56 29-06  
STEERING

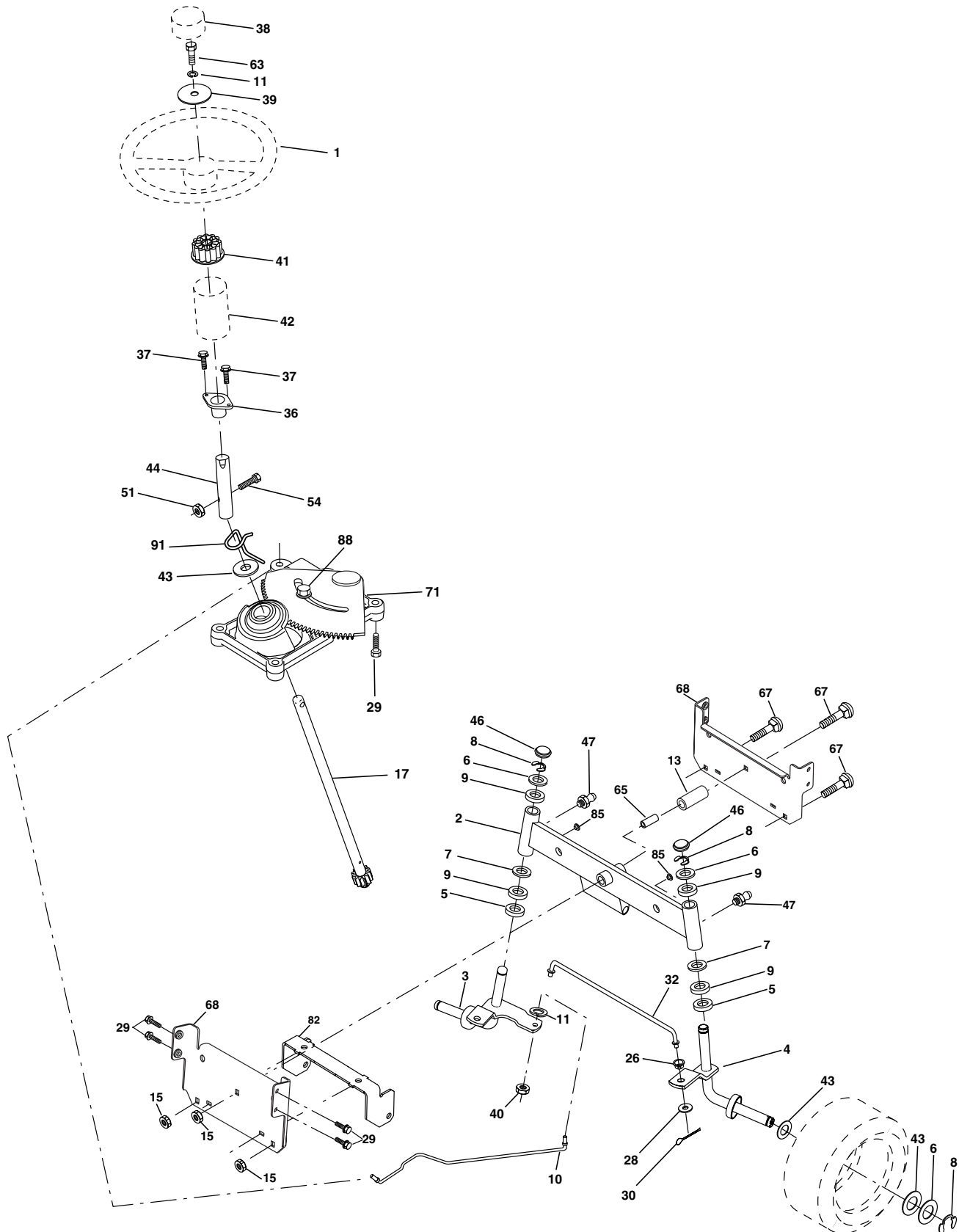

**REPAIR PARTS**

**TRACTOR - - MODEL NUMBER WE12538K, PRODUCT NO. 954 56 29-06**  
**STEERING**

KEY NO.	PART NO.	DESCRIPTION
1	133741X428	Wheel Steering Ayp/P/L Blk
2	175131	Axle Asm
3	169840	Spindle Asm LH
4	169839	Spindle Asm RH
5	6266H	Bearing Race Thrust Harden
6	121748X	Washer 25/32 X 1-5/8 X 16 Ga
7	19272016	Washer 27/32 X 1-1/4 X 16 Ga
8	12000029	Ring Klip #t5304-75
9	3366R	Bearing Col Strg Blk
10	175121	Link Drag
11	10040600	Washer Lock Hvy Hlcl Spr 3/8
13	136518	Spacer earing Axle Front
15	145212	Hexflange Lock
17	177876	Shaft Asm Strg
26	126847X	Bushing Link Drag Blk LR
28	19131416	Washer 13/32 X 7/8 X 16 Ga
29	17060612	Screw 3/8-16 x 3/4
30	76020412	Pin Cotter 1/8 X 3/4 Cad
32	130465	Rod Tie Wire Form 19 75 Mech
36	155099	Bushing Strg 5/8 Id Dash
37	152927	Screw
38	133742X428	Cap Wheel Steer Ayp
39	19133812	Washer 13/32 x 2-3/8 x 12 Ga.
40	7810H	Nut Lock Center 3/8-24un
41	100711L	Adaptor Wheel Strg
42	145054X428	Boot Dash Mtl Steering Blk
43	121749X	Washer 25/32 X 1 1/4 X 16 Ga
44	153720	Extension Steering
46	121232X	Cap Spindle Fr Top Blk
47	6855M	Fitting Grease
51	73800500	Nut Lock Hex W/Ins 5/16-18
54	74780520	Bolt Fin Hex 3/8-16unc x 1-1/4
63	74780616	Bolt Fin Hex 3/8-16unc x 1 Gr.5
65	160367	Spacer Brace Axle
67	72140618	Bolt Fin Hex 5/8-11 unc x 2-3/4
68	169827	Brace Axle
71	175146	Steering Asm.
82	169835	Bracket Susp Chassis Front
85	133835	Fastener Christmas Tree
88	175118	Bolt Shoulder 7/16-20
91	175553	Clip Steering

**NOTE:** All component dimensions given in U.S. inches  
1 inch = 25.4 mm.

# REPAIR PARTS

TRACTOR - - MODEL NUMBER WE12538K, PRODUCT NO. 954 56 29-06  
ENGINE

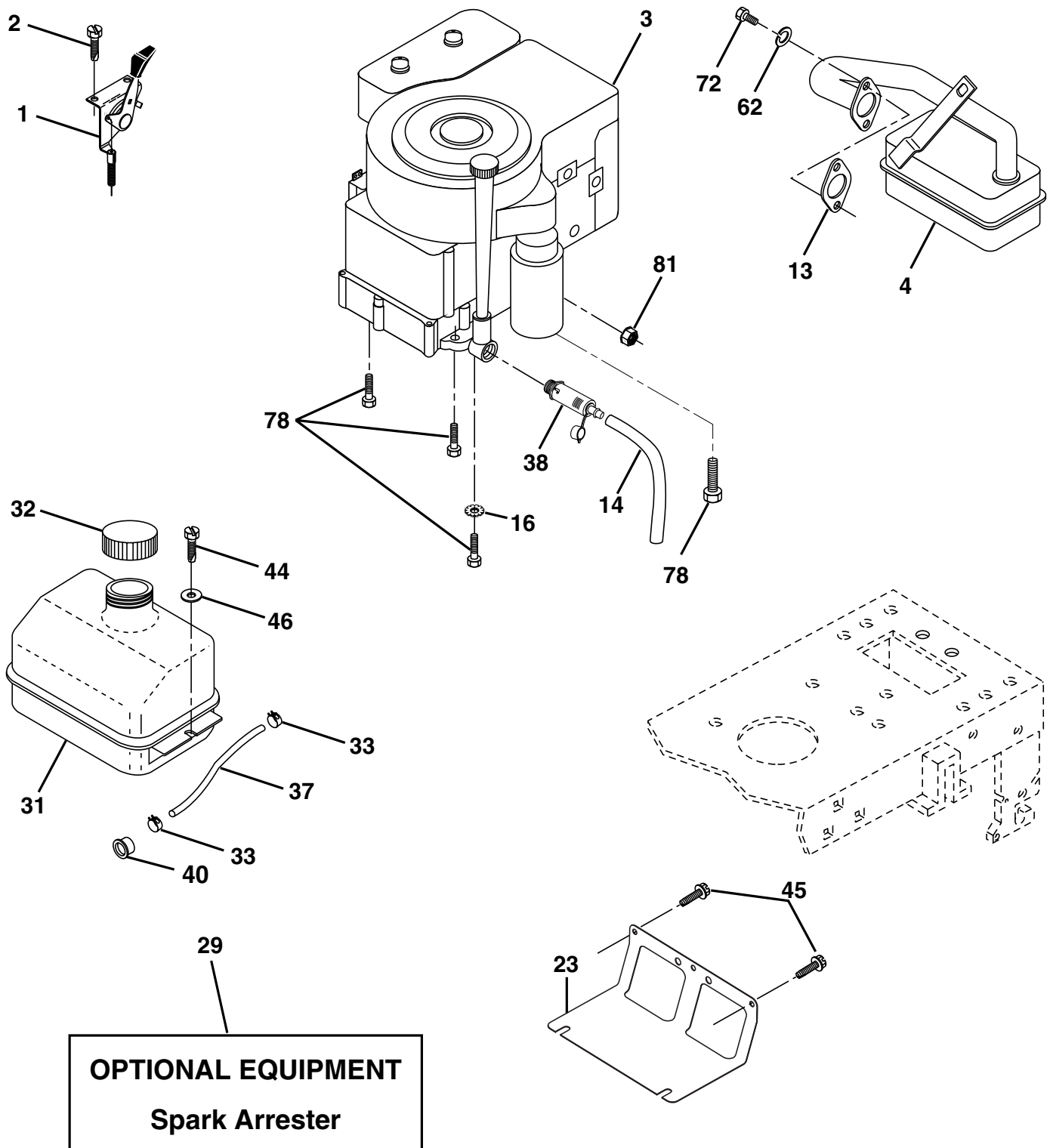

**OPTIONAL EQUIPMENT**  
**Spark Arrester**

## REPAIR PARTS

TRACTOR - - MODEL NUMBER WE12538K, PRODUCT NO. 954 56 29-06  
ENGINE

KEY NO.	PART NO.	DESCRIPTION
1	170551	Control Th/ch Flag
2	17720408	Screw Hex Thd Cut 1/4-20 x 1/2
3	-----	Engine, B&S 289707 (Order parts from engine manufacturer)
4	137348	Muffler Exhaust B&S Lc
13	165291	Gasket Eng 1 313 Id Tin Plated
14	148456	Tube Drain Oil Easy
16	11050600	Washer Lock Ext Tooth 3/8
23	169837	Shield BRN/DBR Guard
29	137180	Kit Spark Arrestor (Flat Scrn)
31	109202X	Tank Fuel Front
32	140527	Cap Asm Fuel
33	123487X	Clamp Hose
37	137040	Line Fuel 20"
38	148315	Plug Drain Oil Easy
40	124028X	Bushing Snap Nyl Blk Fuel Line
44	17670412	Screw Thdrol 1/4-20 x 3/4
45	17000612	Screw Hex Wsh Thdrol 3/8-16
46	19091416	Washer 9/32 X 7/8 X 16 Ga
62	10040500	Washer Lock Hvy Hlcl Spr
72	71070512	Screw Hexcap 5/16-18 x 3/4
78	17060620	Screw 3/8-16 x 1-1/4
81	73510400	Nut Keps Hex 1/4-20 Unc

**NOTE:** All component dimensions given in U.S. inches  
1 inch = 25.4 mm

# REPAIR PARTS

TRACTOR - - MODEL NUMBER WE12538K, PRODUCT NO. 954 56 29-06  
SEAT

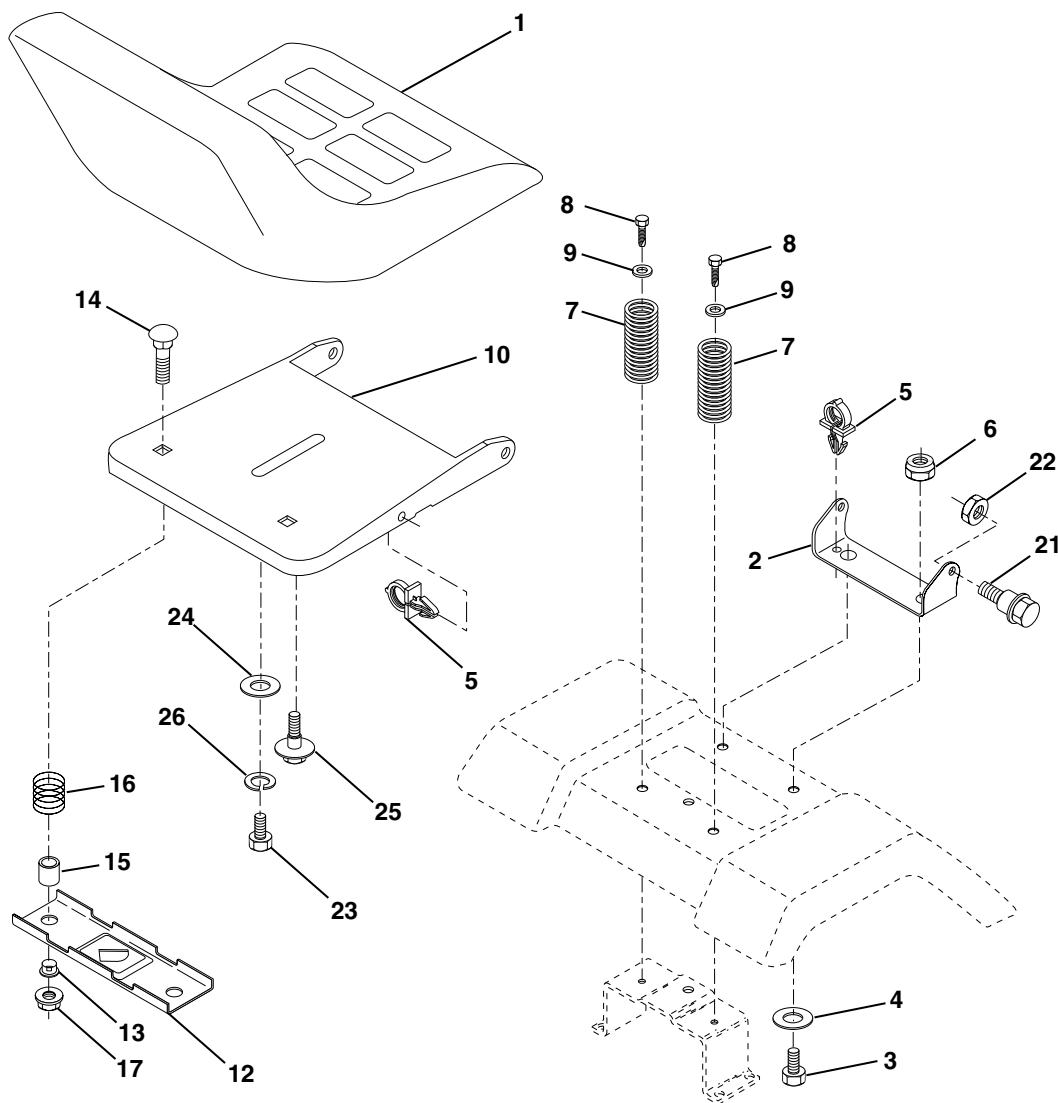

KEY NO.	PART NO.	DESCRIPTION
1	127426X	Seat
2	140551	Bracket Seat Pivot
3	71110616	Bolt Hex 3/8 - 16 X 1
4	19131610	Washer 13/32 X 1 X10Ga.
5	145006	Clip Push-In Hinged
6	73800600	Nut Lock Hex w/Ins 3/8 - 16
7	124181X	Spring Seat Cprsn 2 250 Blk Zi
8	17000616	Screw 3/8-16 x 1.5
9	19131614	Washer 13/32 X 1 X 14 Ga
10	174894	Pan Pnt Seat (Blk)
12	121246X	Bracket Pnt Mounting Switch
13	121248X	Bushing Snap Blk Nyl

KEY NO.	PART NO.	DESCRIPTION
14	72050412	Bolt Rdhd Sht Nk 1/4 - 20 X 1 -1/2
15	134300	Spacer Split .28 X .96
16	121250X	Spring Cprsn
17	123976X	Nut Lock 1/4 Lge Flg
21	171852	Bolt Shoulder 5/16-18 Unc-2A
22	73800500	Nut Lock Hex w/Ins 5/16 - 18
23	71110814	Bolt Hex
24	19171912	Washer 17/32 X 1-3/16 X 12 Ga
25	127018X	Bolt Shoulder 5/16-18 X .62
26	10040800	Washer Lock Hvy Hlcl Spr 1/2

**NOTE:** All component dimensions given in U.S. inches  
1 inch = 25.4 mm.

# REPAIR PARTS

TRACTOR - - MODEL NUMBER WE12538K, PRODUCT NO. 954 56 29-06

## DECALS

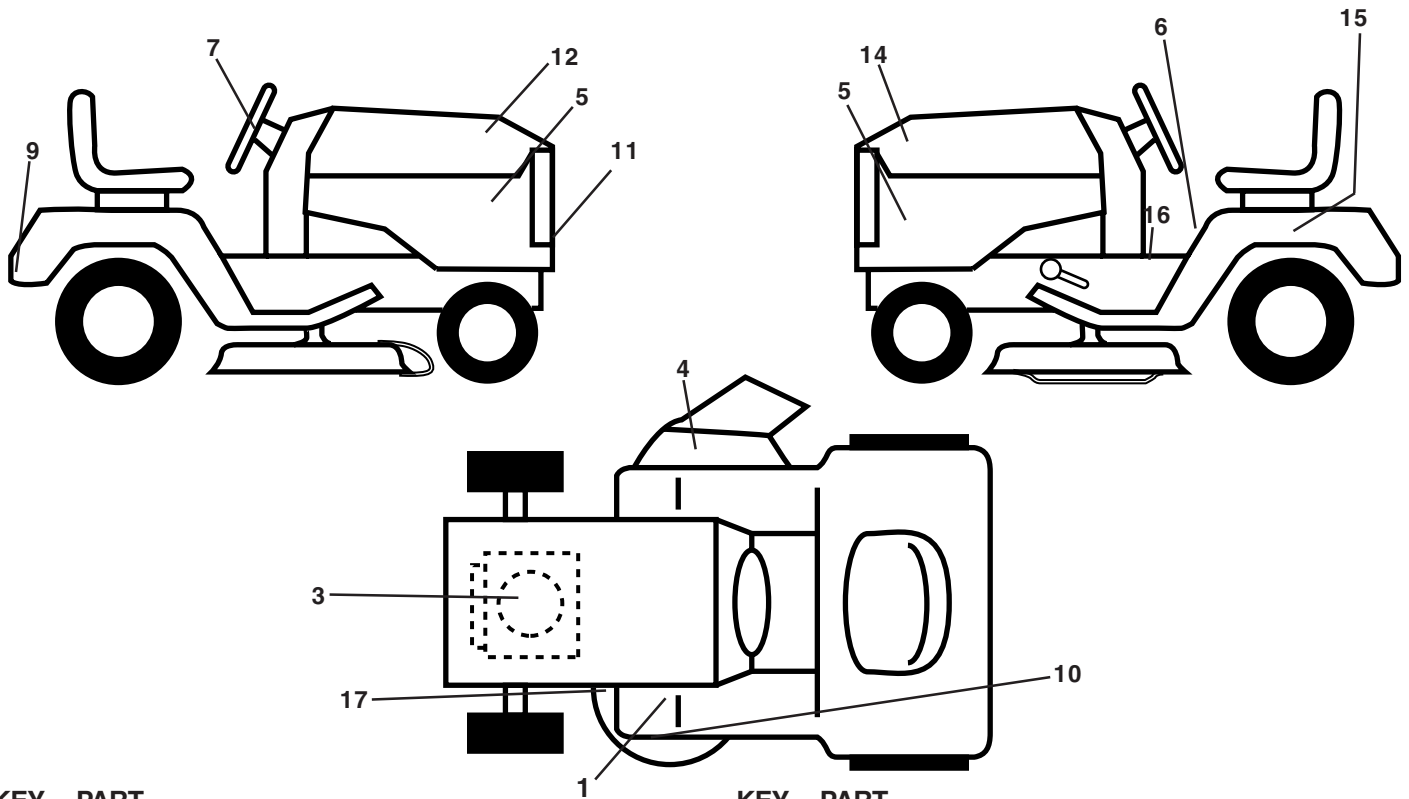

KEY NO.	PART NO.	DESCRIPTION
1	181251	Decal, Clutch/Brake Eng/Fr
3	170839	Decal, Engine HP
4	170563	Decal Warning
5	168421	Decal, Pnl Sd
6	157140	Decal, Fender Danger English
7	162398	Decal Ins Str Wh
9	171448	Decal Fender
10	162391	Decal, Deck Grasseater
11	162392	Decal, Grille Weedeater
12	162389	Decal, Hood RH
14	162390	Decal, Hood LH
15	145005	Decal, Caution, Battery

KEY NO.	PART NO.	DESCRIPTION
16	157163	Decal, Oper Sdl P/L Gear Dr Eng
17	136832	Decal, V-Belt Sch.
--	138311	Decal, Handle Lft Height Adj.
--	181544	Manual, Owner's English
--	151545	Manual, Owner's French

Available accessories not included with mower:

--	C38	Grass Catcher
--	MK38	Mulch Kit w/Blades
--	LSB42	42" Snow Blower
--	LC05	Wheel Weights
--	LBD48	48" Snow Blade
--	CH11	Tire Chains

## WHEELS & TIRES

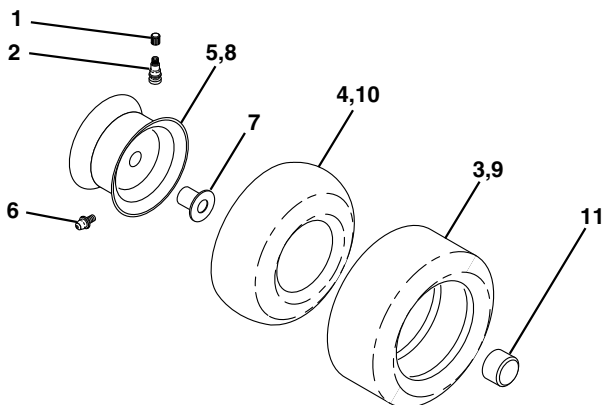

KEY NO.	PART NO.	DESCRIPTION
1	59192	Cap, Tire valve
2	65139	Stem, Valve
3	106222X	Tire, Front
4	59904	Tube, Front (Service item only)
5	106732X427	Rim assembly, 6" front
6	278H	Fitting, Grease (Front wheel only)
7	9040H	Bearing, Flange (Front wheel only)
8	106108X427	Rim assembly, 8" rear
9	124635X	Tire, Rear
10	7152J	Tube, Rear (Service item only)
11	104757X428	Cap, Hub Axle
--	144334	Sealant, Tire (10 oz. Tube)

**NOTE:** All component dimensions given in U.S. inches  
1 inch = 25.4 mm

# REPAIR PARTS

TRACTOR - - MODEL NUMBER WE12538K, PRODUCT NO. 954 56 29-06  
MOWER LIFT

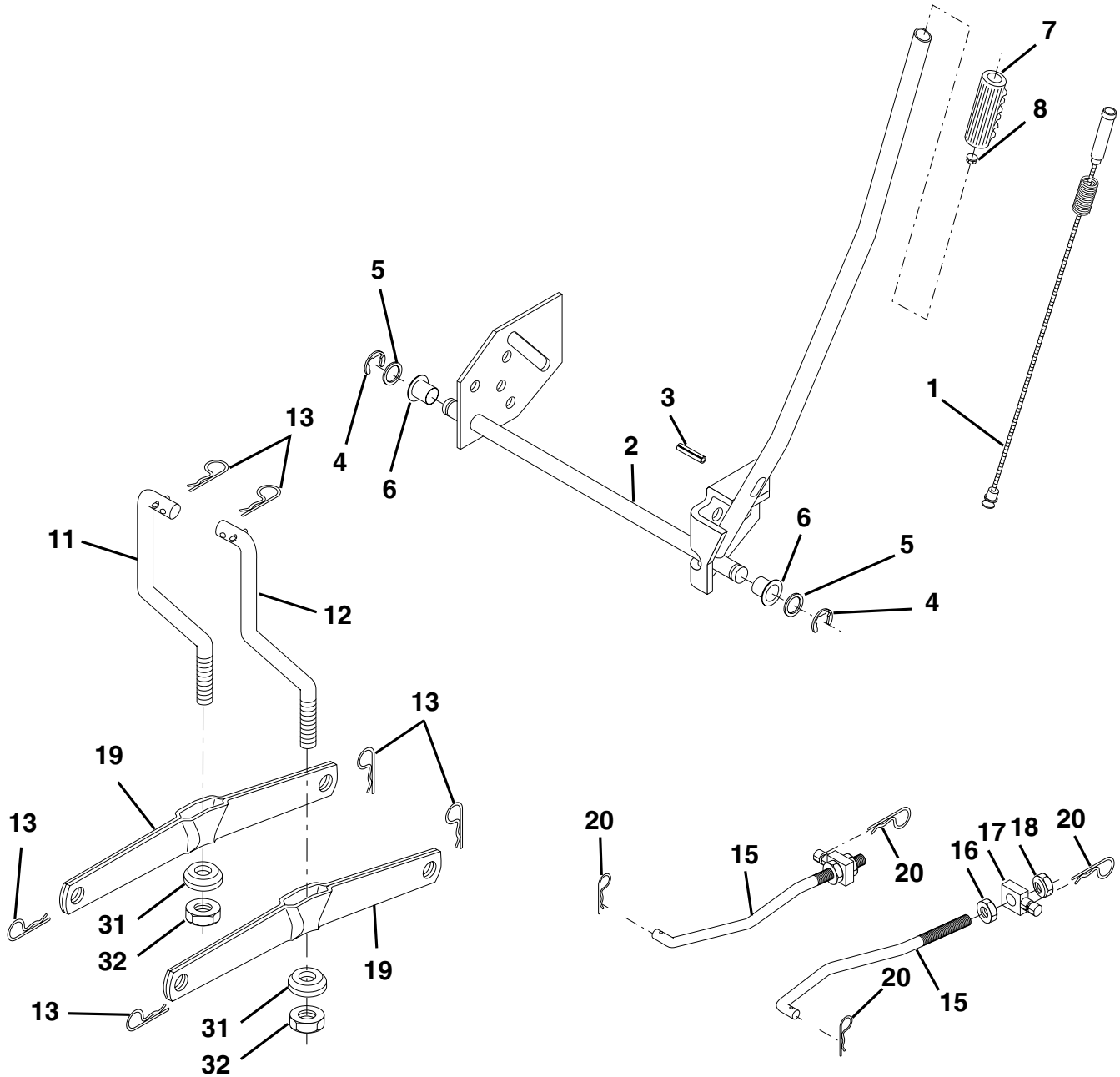



## REPAIR PARTS

TRACTOR - - MODEL NUMBER WE12538K, PRODUCT NO. 954 56 29-06  
MOWER LIFT

KEY NO.	PART NO.	DESCRIPTION
1	159460	Wire Asm Inner/Sprg w/plunger
2	159471	Shaft Asm Lift RH
3	105767X	Pin Groove 1 500 Zinc
4	12000002	E Ring #5133-62
5	19211621	Washer 21/32 X 1 X 21 Ga
6	120183X	Bearing Nylon Blk 629 Id
7	109413X	Grip Handle Bicycle Matte Blk
8	124526X	Button Plunger Black
11	139865	Link Lift LH Fixed Length
12	139866	Link Lift RH Fixed Length
13	4939M	Retainer Spring
15	173288	Link Front
16	73350800	Nut Jam Hex 1/2-13 Unc
17	175689	Trunnion
18	73800800	Nut Lockw/Wsh 1/2-13 Unc
19	139868	Arm Suspension Rear
20	163552	Retainer, Spring
31	169865	Bearing Pvt Lift
32	73540600	Nut Crownlock 3/8-24

**NOTE:** All component dimensions given in U.S. inches  
1 inch = 25.4 mm.

# REPAIR PARTS

TRACTOR - - MODEL NUMBER WE12538K, PRODUCT NO. 954 56 29-06  
MOWER DECK

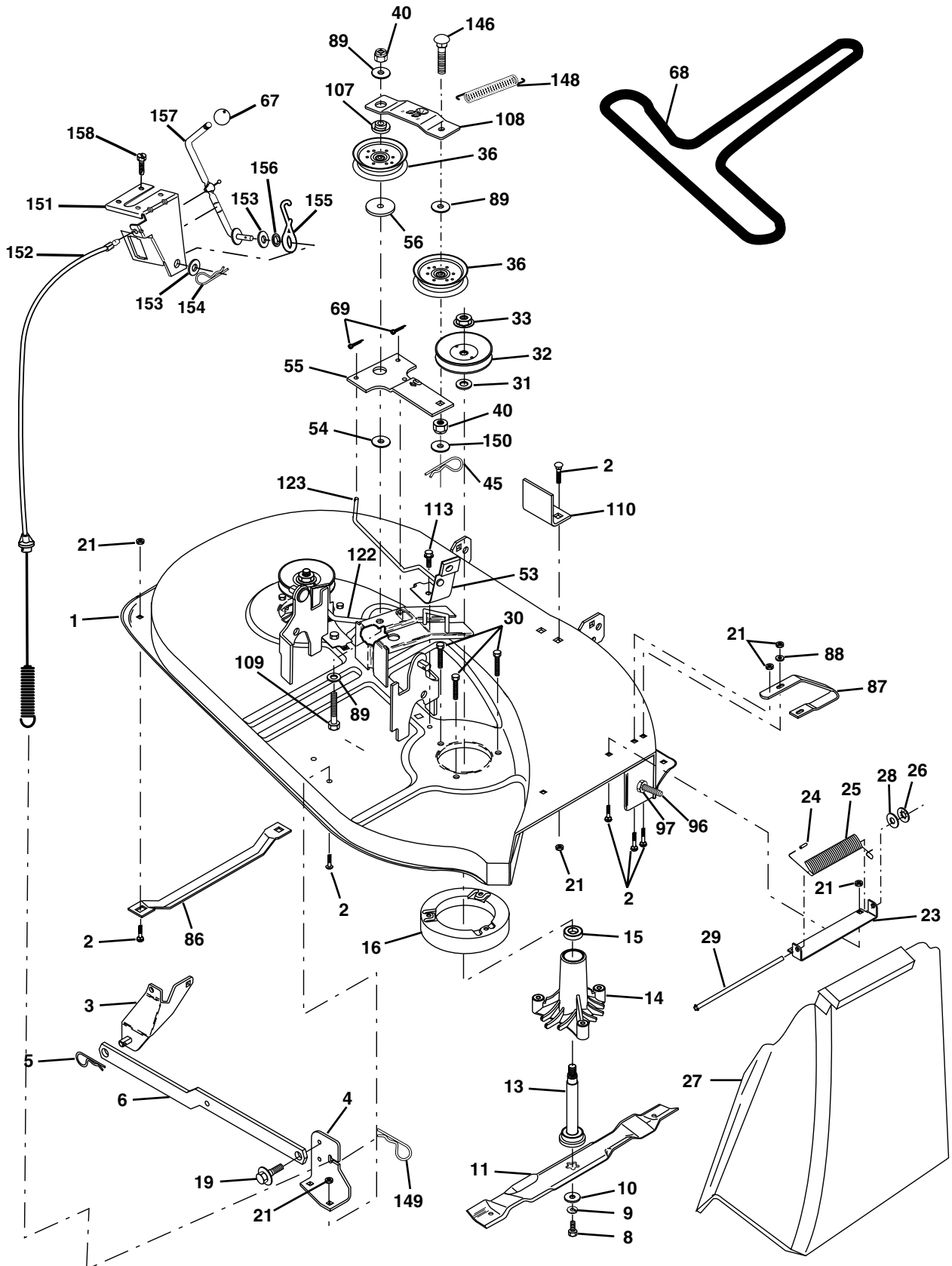

**REPAIR PARTS****TRACTOR - - MODEL NUMBER WE12538K, PRODUCT NO. 954 56 29-06  
MOWER DECK**

KEY NO.	PART NO.	DESCRIPTION	KEY NO.	PART NO.	DESCRIPTION
1	170280	Mower Housing Assembly	67	106932X	Knob
2	72140506	Bolt Carriage 5/16-18 x 3/4	68	144200	V-Belt, 42" Mower
3	138017	Bracket Asm Fr. Sway Bar	69	76020312	Pin, Cotter 3/32 x 3/4
4	169970	Bracket Deck Sway Bar 38"/42"	86	7631J	Runner, LH
5	4939M	Retainer Spring	87	128772	Runner, RH
6	178024	Bar Sway Deck	88	19111216	Washer 11/32 x 3/4 x 16 Ga
8	850857	Bolt 3/8-24 x 1.25 Grade 8	89	19131612	Washer 13/32 x 1 x 12 Ga.
9	10030600	Washer, Lock 3/8	96	74930620	Bolt 3/8-16 x 1-1/4 Mulcher
10	140296	Washer, Hardened	97	73930600	Nut Centerlock 3/8-16 Unc
11	138497	Blade Mower	107	133502	Spacer Retainer
13	137645	Shaft Assembly, Mandrel, Vented (Includes Key Number 6)	108	133503	Stiffener, Idler Arm
14	128774	Housing, Mandrel, Vented	109	74760640	Bolt, Hex Hd 3/8-16 x 2-1/2
15	110485X	Bearing, Ball, Mandrel	110	142587	Upstop Deck Front 38"
16	174493	Stripper, Vented Mower Deck	113	17060512	Screw 5/16-1/ x 3/4
19	132827	Bolt, Shoulder	122	131289	Rod, Brake LH
21	73680500	Nut	123	169971	Rod, Brake RH
23	137607	Bracket, Mower Deflector	146	165891	Bolt Carriage Idler
24	105304X	Cap, Sleeve	148	169022	Spring Return Idler
25	123713X	Spring, Torsion, Deflector	149	165898	Retainer Spring Yellow
26	110452X	Nut, Push	150	19091216	Washer 9/32 x 3/4 x 16 Ga.
27	106736X428	Shield, Deflector	151	169670	Bracket Clutch Cable
28	19111016	Washer 11/32 x 5/8 x 16 Gauge	152	172758	Clutch Cable 38"/46"
29	106735X	Rod, Hinge	153	169674	Washer Flat 3/8" Type B
30	173984	Screw Thdrol. Washer Head	154	169675	Spring Retainer
31	129963	Washer, Spacer	155	169671	Spring Retention LVR CLTCH CAB
32	153532	Pulley, Mandrel	156	169672	Spacer Clutch Cable
33	178342	Nut, Toplock	157	169669	Rod Clutch Cable 3/8"
36	131494	Pulley, Idler, Flat	158	17720408	Screw Hex Thd Cut 1/4-20 x 1/2
40	73680600	Nut, Crownlock 3/8-16 Unc	--	130794	Mandrel Assembly (Includes Housing, Shaft and Shaft Hardware Only-Pulley not Included)
45	4497H	Retainer	--	170317	Replacement Mower, Complete
53	130840	Brake Assembly			
54	133943	Washer, Hardened			
55	133840	Idler Arm Assembly			
56	165723	Spacer, Retainer			

**NOTE:** All component dimensions given in U.S. inches  
1 inch = 25.4 mm

---

# SERVICE NOTES

---

## LIMITED WARRANTY

The Manufacturer warrants to the original consumer purchaser that this product as manufactured is free from defects in materials and workmanship. For a period of two (2) years from date of purchase by the original consumer purchaser, we will repair or replace, at our option, without charge for parts or labor incurred in replacing parts, any part which we find to be defective due to materials or workmanship. This Warranty is subject to the following limitations and exclusions.

1. This warranty does not apply to the engine, other than EHP manufactured transaxle/transmission components, battery (except as noted below) or components parts thereof. Please refer to the applicable manufacturer's warranty on these items.
2. Transportation charges for the movement of any power equipment unit or attachment are the responsibility of the purchaser. Transportation charges for any parts submitted for replacement under this warranty must be paid by the purchaser unless such return is requested by Electrolux Home Products.
3. Battery Warranty: On products equipped with a Battery, we will replace, without charge to you, any battery which we find to be defective in manufacture, during the first ninety (90) days of ownership. After ninety (90) days, we will exchange the Battery, charging you 1/12 of the price of a new Battery for each full month from the date of the original sale. Battery must be maintained in accordance with the instructions furnished.
4. The Warranty period for any products used for rental or commercial purposes is limited to 90 days from the date of original purchase.
5. This Warranty applies only to products which have been properly assembled, adjusted, operated, and maintained in accordance with the instructions furnished. This Warranty does not apply to any product which has been subjected to alteration, misuse, abuse, improper assembly or installation, delivery damage, or to normal wear of the product.
6. Exclusions: Excluded from this Warranty are belts, blades, blade adapters, normal wear, normal adjustments, standard hardware and normal maintenance.
7. In the event you have a claim under this Warranty, you must return the product to an authorized service dealer.

Should you have any unanswered questions concerning this Warranty, please contact:

Electrolux Home Products, Inc.  
Outdoor Products Customer Service Dept.  
250 Bobby Jones Expressway  
Augusta, GA 30909 USA

In Canada contact:  
Electrolux Canada Corp.  
7075 Ordan Drive  
Mississauga, Ontario  
L5T 1K6

giving the model number, serial number and date of purchase of your product and the name and address of the authorized dealer from whom it was purchased.

THIS WARRANTY DOES NOT APPLY TO INCIDENTAL OR CONSEQUENTIAL DAMAGES AND ANY IMPLIED WARRANTIES ARE LIMITED TO THE SAME TIME PERIODS STATED HEREIN FOR OUR EXPRESSED WARRANTIES. Some areas do not allow the limitation of consequential damages or limitations of how long an implied Warranty may last, so the above limitations or exclusions may not apply to you. This Warranty gives you specific legal rights, and you may have other rights which vary from locale to locale.

This is a limited Warranty within the meaning of that term as defined in the Magnuson-Moss Act of 1975.



TECUMSEH

# SERVICE POLICY WARRANTY



TECUMSEH

Issued January 1980  
Revised January 1991

## LIMITED WARRANTIES FOR NEW PEERLESS GEAR POWER TRAIN COMPONENTS

### A. Products Warranted

Peerless Gear and Machine Division of Tecumseh Products Company ("Tecumseh"), subject to the limitations contained below, will, at its option, repair or replace, without charge for parts or labor only, any part of a new Power Train Component (which as used herein means and includes the transaxle, gear box, transmission, differential and right angle drives, and any part of the Power Train Component), EXCEPT any new Power Train Component incorporated in equipment used for commercial or rental purposes, which is found upon examination by any Tecumseh Authorized Service Outlet or by Tecumseh's factory in Grafton, Wisconsin, to be DEFECTIVE IN MATERIAL AND/OR WORKMANSHIP if received by Tecumseh or a Tecumseh Authorized Service Outlet for such examination within TWO YEARS from the date of sale to the original consumer purchaser of Peerless Series 820, 900, 910, 915, 920, 930 transaxles and Series 1100 angle drive and ONE YEAR for all other Peerless products. New Power Train Components incorporated in equipment used for commercial purposes are warranted in the same manner and to the same extent EXCEPT such Power Train Components are warranted for NINETY (90) DAYS ONLY, and must be received by Tecumseh or by a Tecumseh Authorized Service Outlet for such examination within 90 days from the date of sale to the original purchaser. New Power Train Components incorporated in equipment used for rental purposes are warranted in the same manner and to the same extent EXCEPT such Power Train Components are warranted for THIRTY (30) DAYS ONLY, and must be received by Tecumseh or a Tecumseh Authorized Service Outlet within 30 days from the date of sale to the original purchaser.

### B. Products And Items Not Warranted

1. Alterations or Modifications of Power Train Components.
2. Accidents, Normal Maintenance, Failure to follow the Original Equipment Manufacturer's Manual.

This warranty covers only parts of new Power Train Components which are found upon examination to be defective in material or workmanship as delivered to the original purchaser. This warranty does not cover defects caused by depreciation or damage caused by normal wear, accidents, improper maintenance, improper use or abuse of the product, failure to follow the instructions contained in an Instruction Manual for the operation of the Power Train Component and parts. The cost of normal maintenance and replacement of service items which are not defective shall be paid for by the original purchaser.

### C. Securing Warranty Service

Warranty service can be arranged for by contacting either a Tecumseh Authorized Service Outlet (any Tecumseh Registered Service Dealer, Tecumseh Authorized Service Distributor, or Tecumseh Central Warehouse Distributor) or by contacting Tecumseh, c/o Service Manager, Engine and Transmission Group Service Division, 900 North Street, Grafton, Wisconsin 53024. Warranty service can only be performed by a Tecumseh Authorized Service Outlet or by Tecumseh at its factory in Grafton, Wisconsin. At the time of requesting warranty service, evidence must be presented of the date of sale to the original purchaser. The purchaser shall pay any charges for making service calls and/or for transporting the product to and from the place where the inspection and/or warranty work is performed. The purchaser shall be responsible for any damage or loss incurred in connection with the transportation of Power Train Components and/or part(s) of the Power Train Components submitted for inspection and/or warranty work.

### D. Limitation of Damages and Implied Warranties

The foregoing EXPRESSED WARRANTY IS IN LIEU OF ALL OTHER EXPRESS WARRANTIES. Neither Tecumseh nor any of its affiliates makes any warranties, representations or promises, written or oral, as to the quality of the Power Train Component or any of its parts, other than as set forth herein.

ANY IMPLIED WARRANTY OF MERCHANTABILITY OR FITNESS FOR A PARTICULAR PURPOSE, TO THE EXTENT THAT EITHER MAY APPLY TO ANY PART(S) OF POWER TRAIN COMPONENTS, SHALL BE LIMITED IN DURATION TO THE PERIODS OF THE EXPRESSED WARRANTIES DEFINED IN PARAGRAPH A HEREOF. IN NO EVENT WILL TECUMSEH BE LIABLE FOR ANY INCIDENTAL, CONSEQUENTIAL OR SPECIAL DAMAGES AND/OR EXPENSES. Some states do not allow limitations on how long an implied warranty lasts or the exclusion or limitation of incidental or consequential damages, so the above limitation(s) or exclusion(s) may not apply to you. This warranty gives you specific legal rights and you may also have other legal rights which vary from state to state.

### E. No Dealer Warranty

Tecumseh neither assumes nor authorizes any other person, natural or corporate, to assume for Tecumseh any other obligations or liabilities in connection with or with respect to any part(s) of a Power Train Component. The seller or dealer of part(s) of a Power Train Component has no authority, whatsoever, to make any representations or promises on behalf of Tecumseh or to modify the terms or limitations of Tecumseh's warranty in any way.

# SUGGESTED GUIDE FOR SIGHTING SLOPES FOR SAFE OPERATION

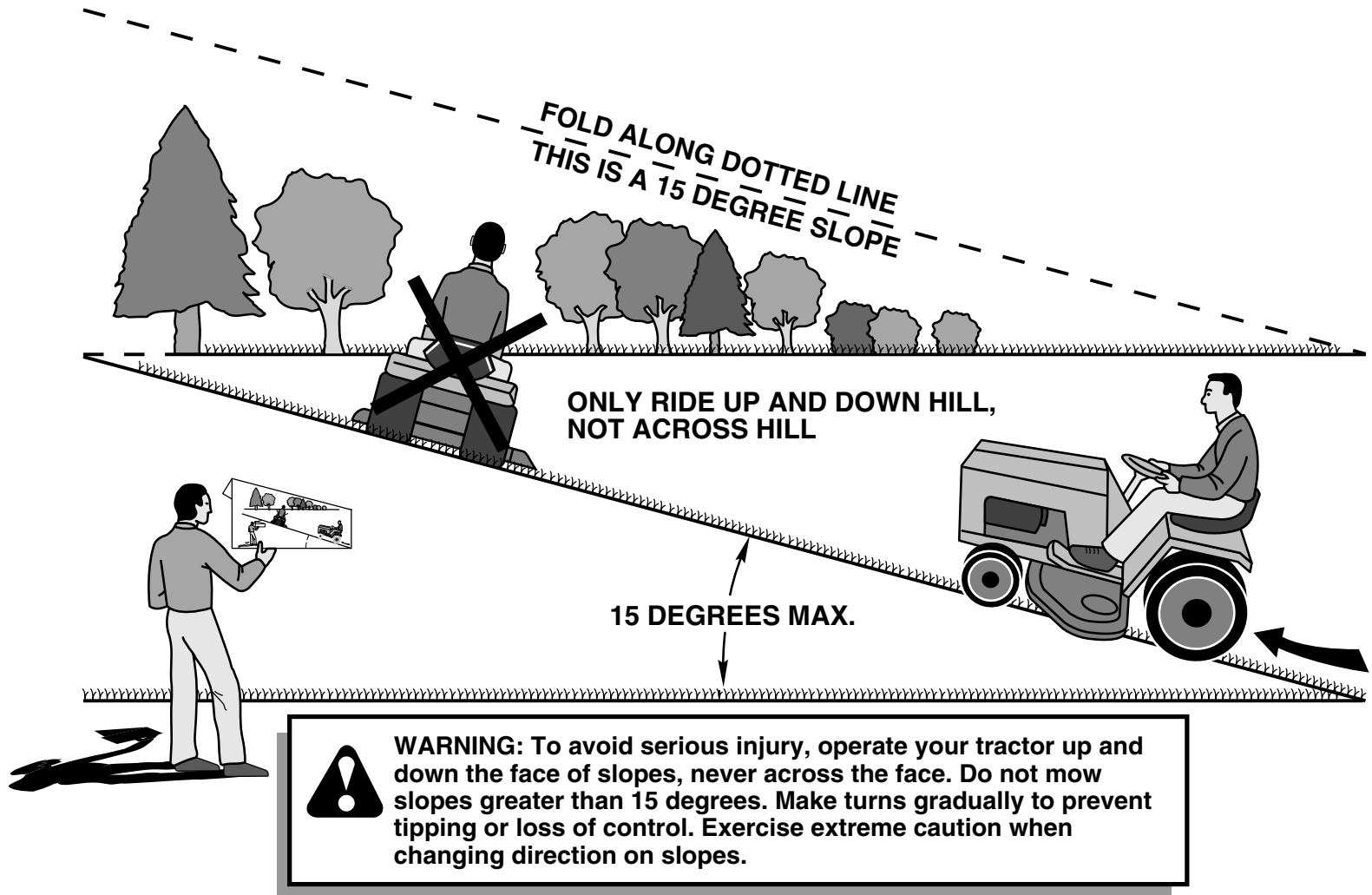

1. Fold this page along dotted line indicated above.
2. Hold page before you so that its left edge is vertically parallel to a tree trunk or other upright structure.
3. Sight across the fold in the direction of hill slope you want to measure.
4. Compare the angle of the fold with the slope of the hill.

For Parts Call K&T 606-678-9623 or 606-561-4983

**WEED EATER®**

[www.mymowerparts.com](http://www.mymowerparts.com)