

TRACTOR - MODEL NUMBER DPR22H46STB

SCHEMATIC

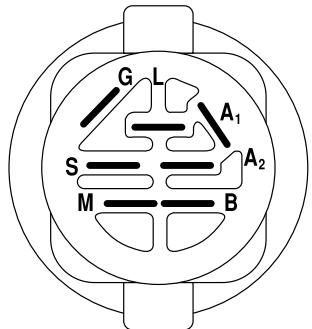
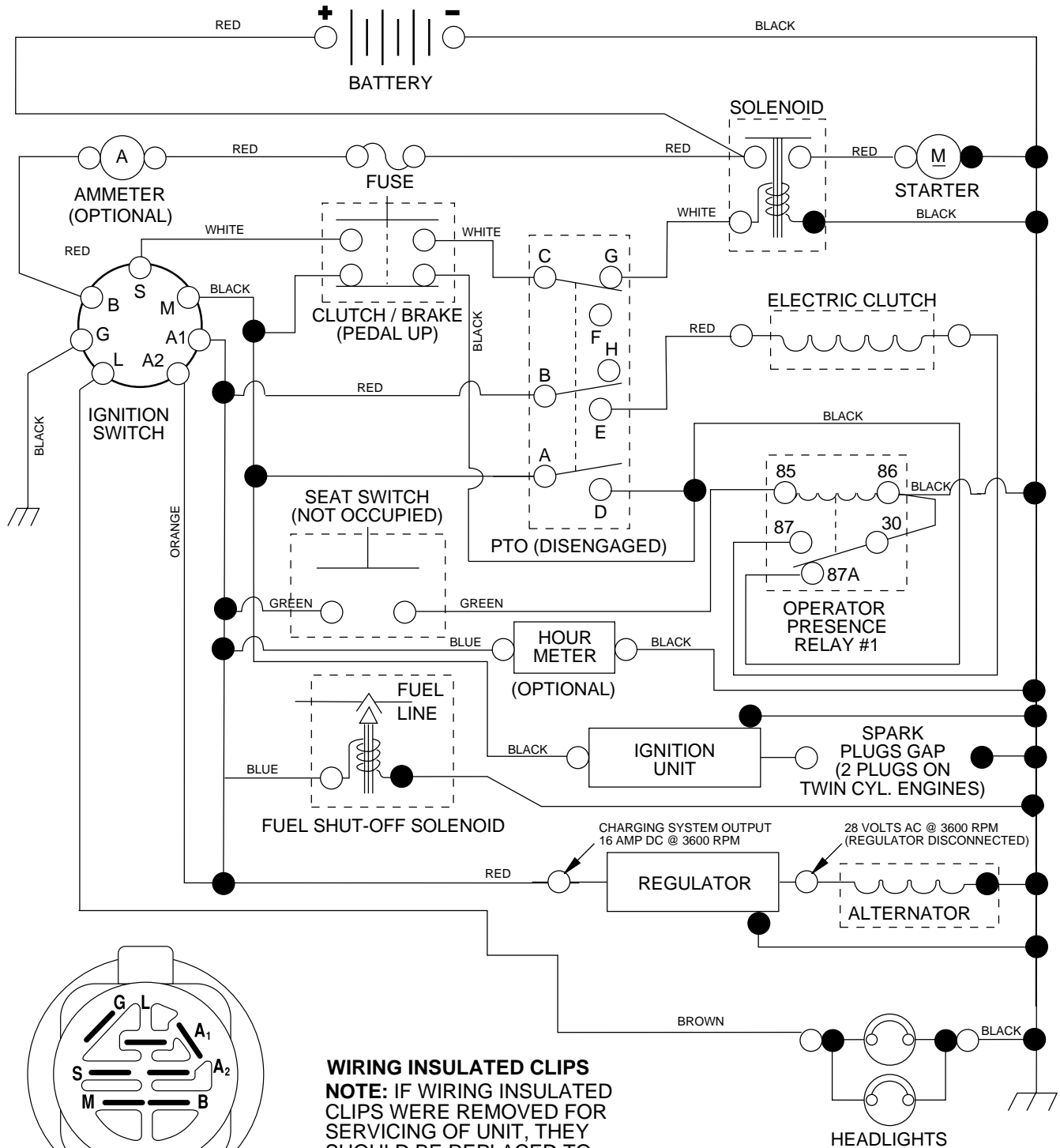

IGNITION SWITCH

POSITION	CIRCUIT	"MAKE"
OFF	M+G+A1	NONE
RUN/LIGHT	B+A1	A2+L
RUN	B+A1	NONE
START	B + S + A1	NONE

WIRING INSULATED CLIPS

NOTE: IF WIRING INSULATED CLIPS WERE REMOVED FOR SERVICING OF UNIT, THEY SHOULD BE REPLACED TO PROPERLY SECURE YOUR WIRING.

PTO SWITCH

POSITION	CIRCUIT
OFF	C + G, B + H
ON	C + F, B + E, A + D

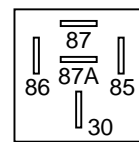
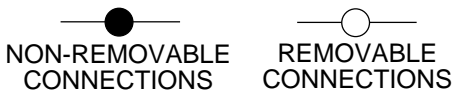

RELAY

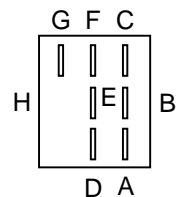

REPAIR PARTS

TRACTOR - MODEL NUMBER DPR22H46STB

ELECTRICAL

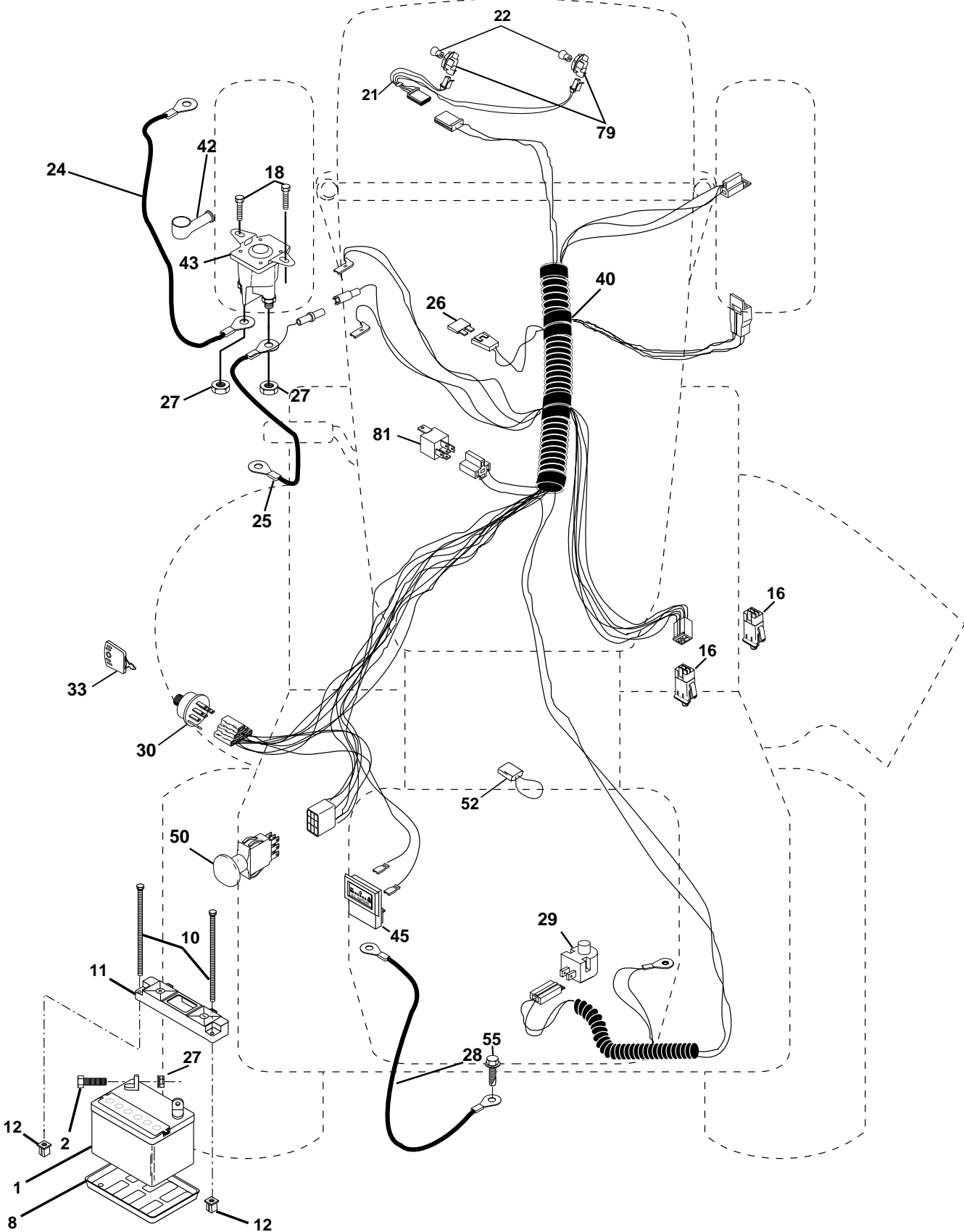

REPAIR PARTS

TRACTOR - MODEL NUMBER DPR22H46STB

ELECTRICAL

KEY NO.	PART NO.	DESCRIPTION
1	163465	Battery
2	74760412	Bolt Hex Hd 1/4-20 UNC X 3/4
8	7603J	Tray, Battery
10	145211	Bolt, BTR FRT 1/4-20 x 7.5
11	150109	Hold Down Battery, Front
12	145769	Nut, Push, Nylon
16	153664	Switch Interlock Push-In
18	17720408	Screw Thd 1/4-20 x1/2
21	166184	Harness Asm Light W/4152j
22	4152J	Bulb Light #1156
24	8860R	Cable Battery
25	146148	Cable Batterywire
26	175158	Fuse
27	73510400	Nut Keps Hex 1/4-20 Unc
28	145491	Cable Ground
29	160784	Switch Plunger Normal OP Olive
30	175566	Switch Ign 4 pos w/lights
33	140401	Key Ign
40	178450	Harness Ign.
42	131563	Cover Terminal Red
43	178861	Solenoid
45	122822X	Ammeter Rectangular
50	174653	Switch, PTO
52	141940	Protection Wire Loop
55	17490508	Screw Thdrol 5/16-18 x 1/2
79	163996	Bulbholder
81	109748X	Relay Asm

NOTE: All component dimensions given in U.S. inches.
1 inch = 25.4 mm.

REPAIR PARTS

TRACTOR - MODEL NUMBER DPR22H46STB

CHASSIS AND ENCLOSURES

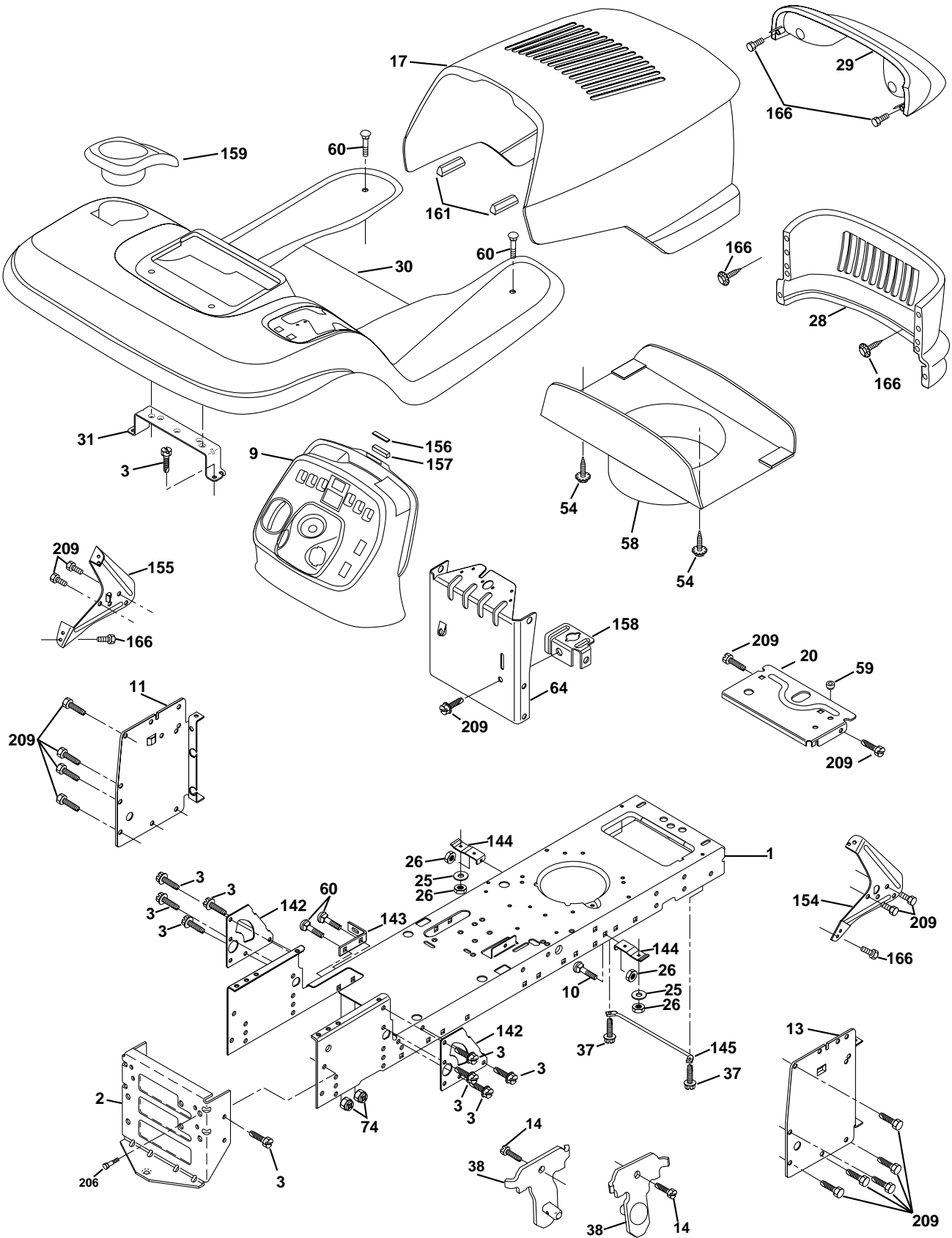

REPAIR PARTS**TRACTOR - MODEL NUMBER DPR22H46STB****CHASSIS AND ENCLOSURES**

KEY NO.	PART NO.	DESCRIPTION	KEY NO.	PART NO.	DESCRIPTION
1	174619	Chassis	64	174997	Dash Lower
2	176554	Drawbar	74	73680600	Nut Crownlock 3/8-16 Unc
3	17060612	Screw 3/8-16x3/4	142	165867	Plate Reinforcement STLT
9	163976X428	Dash	143	154966	Bracket Swaybar Chassis
10	72140608	Bolt Carriage 3/8-16 x 1	144	175582	Bracket Footrest
11	167203	Panel Dash Lh	145	156524	Rod Pivot Chassis/Hood
13	167202	Panel Dash Rh	154	161897	Bracket Dash Rh
17	175259X428	Hood	155	161900	Bracket Dash Lh
18	126938X	Bumper Hood	156	163805	Striker Plate
20	162026	Plate Battery	157	163806	Magnet Stealth
25	19131312	Washer 13/32 X 13/16 X 12 Ga	158	162037	Bracket Parking Brake
26	73800600	Nut Lock Hex W/Ins 3/8-16 Unc	159	155123X428	Cupholder
28	175289X428	Grille	161	164655	Extrusion Bumper
29	161235	Lens	166	164863	Screw HwHd Hi-Lo #13-16 x 3/4
30	175692X428	Fender	206	170165	Bolt Shoulder 5/16-18
31	139976	Bracket Fender	209	17000612	Screw Hexwsh Thdrol 3/8-16 x 3/4
37	17490508	Screw Thdrol 6/16-18 x 1/2 TYT	213	169848X428	Skirt Grille Lh
38	175710	Bracket, Asm. Pivot Mower Rear	214	169847X428	Skirt Grille Rh
54	161464	Screw Hex Wshd 8-18 x 7/8			
58	161236	Duct Hood			
59	110436X	Bushing Snap			
60	72140606	Bolt RdHd Sqnk 3/8-16 Unc x 3/4			

NOTE: All component dimensions given in U.S. inches
1 inch = 25.4 mm

REPAIR PARTS

TRACTOR - MODEL NUMBER DPR22H46STB

DRIVE

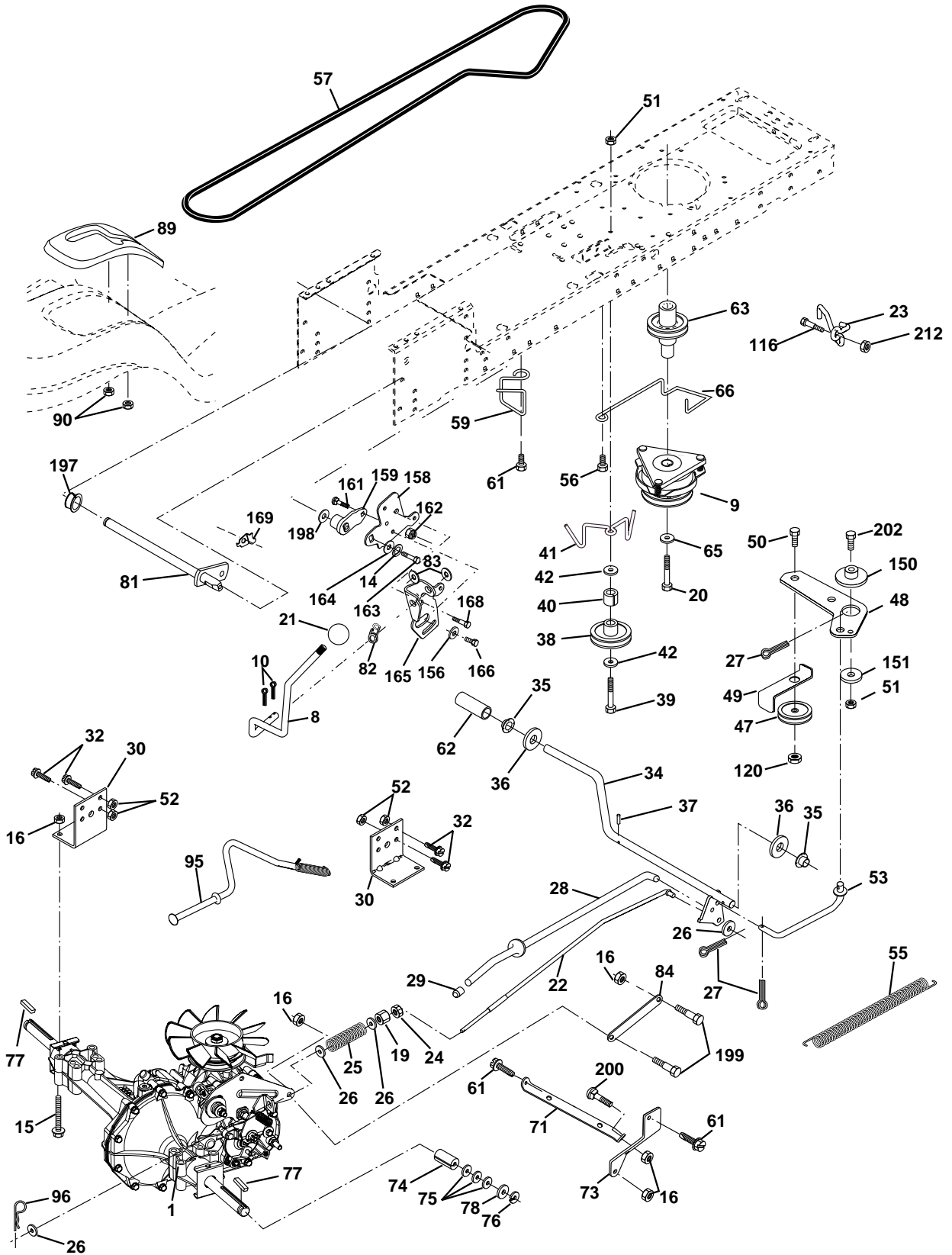

REPAIR PARTS**TRACTOR - MODEL NUMBER DPR22H46STB****DRIVE**

KEY NO.	PART NO.	DESCRIPTION	KEY NO.	PART NO.	DESCRIPTION
1	-----	Transaxle, Hydro Gear 314-0510 (Order Parts From Transaxle Manufacturer)	62	8883R	Cover, Pedal
8	165866	Rod Shift Fender	63	175417	Pulley, Engine
9	137140	Clutch Electric	65	10040700	Washer
10	76020416	Pin Cotter 1/8 x 1 CAD	66	154778	Keeper Belt Engine Hydro
14	10040400	Washer Lock Hvy Helical	71	169183	Strap Torque Lh Hydro
15	74490544	Bolt Hex Flghd 5/16-18 Gr. 5	73	169182	Strap Torque Rh Hydro
16	73800500	Nut Lock Hex W/Ins. 5/16-18 Unc	74	137057	Spacer, Axle
19	73800600	Nut Lock Hex W/Wsh 3/8-16 Unc	75	121749X	Washer 25/32 x 1-1/4 x 16 Ga.
20	150280	Bolt, Hex 7/16-20 x 4-1/4	76	12000001	E-Ring
21	140845	Knob Deluxe	77	123583X	Key, Square
22	169498	Rod, Brake Hydro	78	121748X	Washer 25/32 x 1-5/8 x 16 Ga.
23	178289	Bracket Asm. Anti Rotation	81	165596	Shaft Asm. Cross Hydro
24	73350600	Locknut	82	165711	Spring Torsion T/A
25	106888X	Spring, Brake Rod	83	19171216	Washer 17/32 x 3/4 x 16 Ga.
26	19131316	Washer	84	169594	Link Transaxle
27	76020412	Pin Cotter 1/8 x 3/4 CAD.	89	164890X428	Console, Shift
28	175765	Rod, Parking Brake	90	124346X	Nut Self-Thd Wsh-Hd 1/4
29	71673	Cap, Parking Brake	95	170201	Control Asm. Bypass Hydro
30	169592	Bracket, Transaxle	96	4497H	Retainer Spring 1" Zinc/Cad
32	74760512	Bolt Hex Hd 5/16-18 Unc x 3/4	116	72140608	Bolt Rdhd 3/8-16 x 1
34	155071	Shaft, Foot Pedal	120	73900600	Nut Lock Flg. 3/8-16 Unc
35	120183X	Bearing, Nylon	150	175456	Spacer Retainer
36	19211616	Washer	151	19133210	Washer 13/32 x 2 x 10 Ga.
37	1572H	Pin, Roll	156	166002	Washer Srrted 5/16ID x 1.125
38	165936	Pulley, Composite, Flat	158	165589	Bracket Shift Mount
39	74760648	Bolt	159	165494	Hub Tapered Flange Shift Lt
40	175461	Spacer Split	161	72140406	Bolt Rdhd Sqnk 1/4-20 x 3/4 Gr. 5
41	175556	Keeper, Belt Idler Fool-Proof	162	73680400	Nut Crownlock 1/4-20 Unc
42	19131312	Washer 13/32 x 13/16 x 12 Gauge	163	74780416	Bolt Hex Fin 1/4-20 Unc x 1 Gr. 5
47	127783	Pulley, Idler, V-Groove	164	19091010	Washer 5/8 x .281 x 10 Ga
48	154407	Bellcrank Clutch Grnd Drv Stl	165	165623	Bracket Pivot Lever
49	123205X	Retainer, Belt	166	166880	Screw 5/16-18 x 5/8
50	74760624	Bolt	168	165492	Bolt Shoulder 5/16-18 x .561
51	73680600	Nut	169	165580	Plate Fastening Lt\
52	73680500	Nut Crown Lock 5/16-18	197	169613	Nyliner Snap-In 5/8" ID
53	105710X	Link, Clutch	198	169593	Washer Nyliner 7/8 ID x .105
55	105709X	Spring, Return, Clutch	199	169612	Bolt Shoulder 5/16-18 Unc
56	17060616	Screw 3/8-16 x 1	200	72140508	Bolt Rdhd Sqnk 5/16-18 UNC x 1
57	140294	V-Belt, Ground Drive	202	72110612	Bolt Carr Sh 3/8-16 x 1-1/2 Gr.5
59	169691	Keeper, Center Span	212	145212	Nut Hex Flange Lock
61	17060612	Screw 3/8-16 x 3/4			

NOTE: All component dimensions give in U.S. inches.
1 inch = 25.4 mm

REPAIR PARTS

TRACTOR - MODEL NUMBER DPR22H46STB

STEERING ASSEMBLY

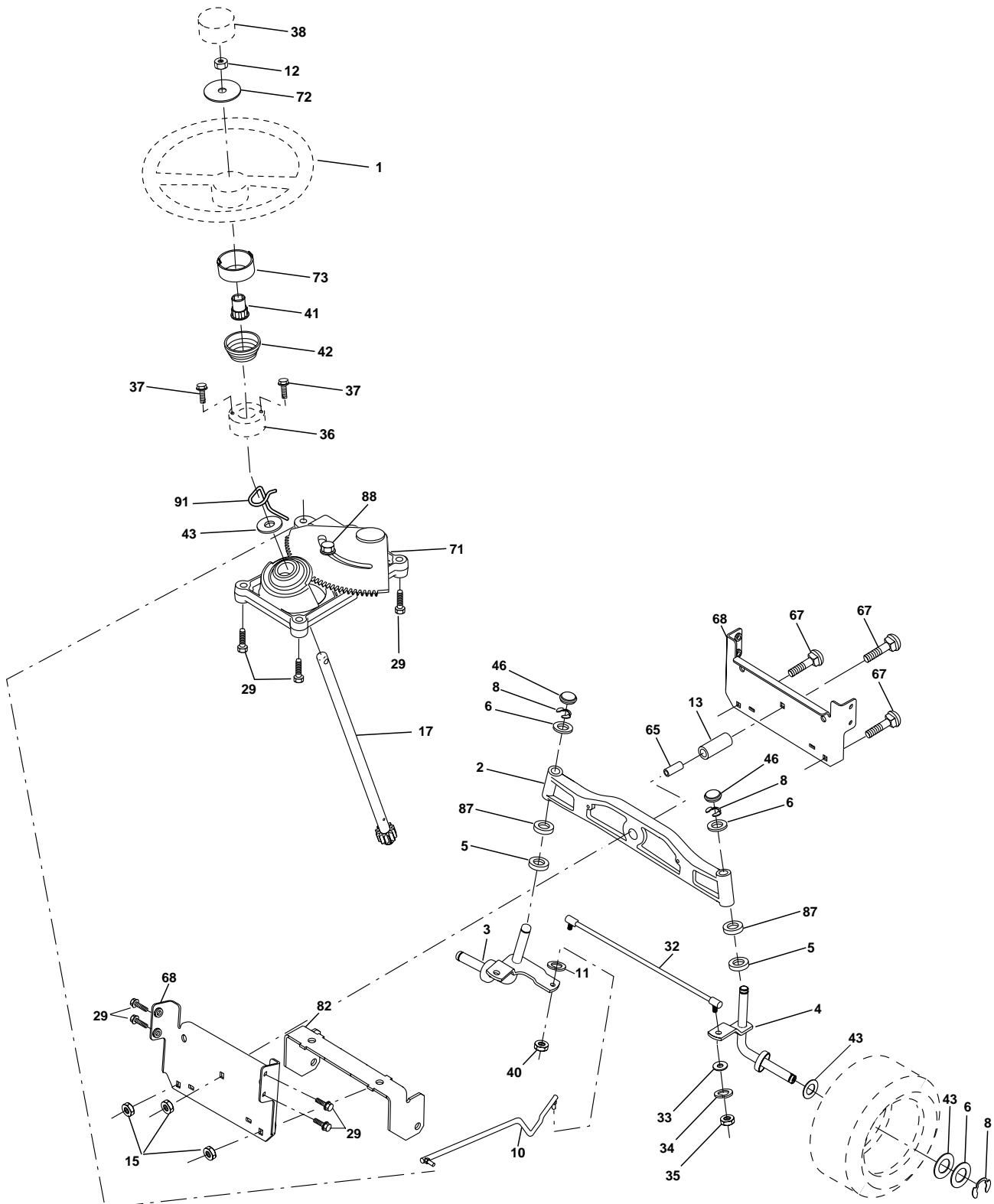

REPAIR PARTS**TRACTOR - MODEL NUMBER DPR22H46STB****STEERING ASSEMBLY**

KEY NO.	PART NO.	DESCRIPTION
1	159944X428	Wheel Steering
2	172393	Axle Cast Lt Machined
3	169840	Spindle Asm LH
4	169839	Spindle Asm RH
5	6266H	Bearing Race Thrust Harden
6	121748X	Washer 25/32 X 1-5/8 X 16 Ga
8	1200029	Ring Klip #t5304-75
10	175121	Link Drag
11	10040600	Washer Lock Hvy Hlcl Spr 3/8
12	73940800	Nut Hex Jam Toplock 1/2-20 UNF
13	136518	Spacer Brg Axle Front
15	145212	Nut Hex Flange Lock
17	177883	Shaft Asm Strg
29	17060612	Screw 3/8-16x3/4
32	171888	Rod Tie
33	19111216	Washer 11/32 x 3/4 x 16 Ga.
34	10040500	Washer Lock Hry Hlcl Spr 5/16
35	73540500	Nut Crownlock 5/16 - 24 UNF
36	155105	Bushing Strg
37	152927	Screw TT #32.5 x 5 x 3/8 Flange
38	159946X428	Cap Wheel Steer
40	7810H	Nut Lock Center 3/8-24 Unf
41	159945	Adaptor Wheel Strg
42	163888X428	Boot Steering
43	121749X	Washer 25/32 X 1 1/4 X 16 Ga
46	121232X	Cap Spindle Fr Top Blk
65	160367	Spacer Brace Axle
67	72140618	Bolt Rdhd Sqn 3/8-16 x 2-1/4
68	169827	Brace, Axle
71	175146	Steering Asm.
72	19182411	Washer 9/16 ID x 1/20 OD 11 Ga.
73	160135X428	Extension Steering
82	169835	Bracket Susp Chassis Front
87	173966	Washer Flat .781 x 1-1/2 x .14
88	175118	Bolt Shoulder 7/16-20
91	175553	Clip Steering

NOTE: All component dimensions given in U.S. inches.
1 inch = 25.4 mm.

REPAIR PARTS

TRACTOR - MODEL NUMBER DPR22H46STB

ENGINE

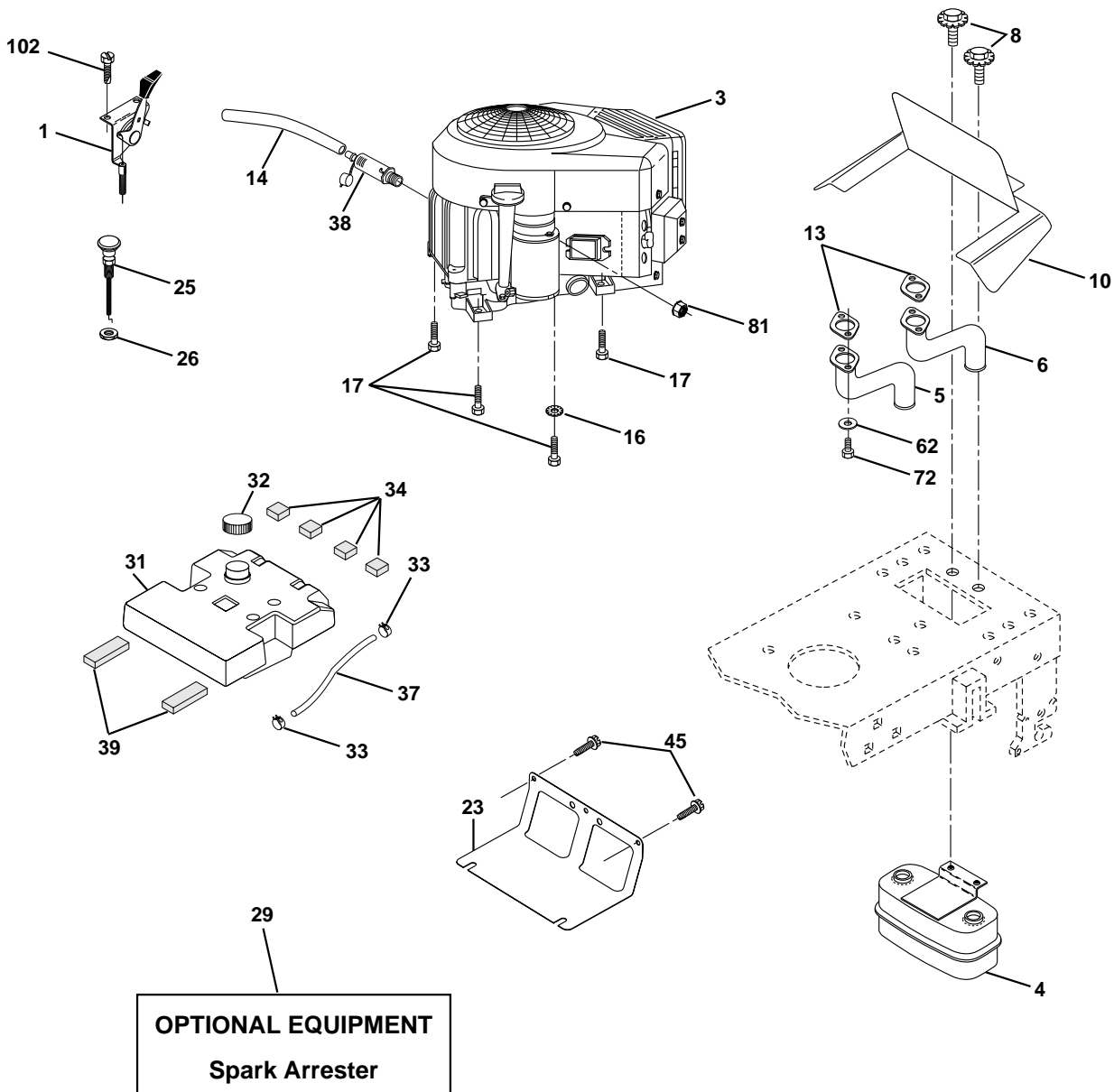

OPTIONAL EQUIPMENT
Spark Arrester

KEY NO.	PART NO.	DESCRIPTION	KEY NO.	PART NO.	DESCRIPTION
1	164067	Control Throttle	31	157103	Tank Fuel 3 50 Rear
3	-----	Engine, Briggs Model 407777 (Order parts from engine mfg.)	32	140527	Cap Asm Fuel W/sym Vented
4	149723	Muffler Asm Twin Lo-Tone	33	123487X	Clamp Hose Black
5	159955	Pipe Exhaust LH Intek	34	106082X	Pad, Spacer
6	160589	Pipe Exhaust RH Intek	37	8543R	Line Fuel
8	171877	Bolt 5/16-18 UNC x 3/4 w/Sems	38	148315	Plug Drain Oil Easy
10	162797	Shield Browning Intek II	39	109227X	Pad, Idler
13	165391	Muffler Gasket	45	17000612	Screw Hexwsh Thdr 3/8-16 x 3/4
14	148456	Tube Drain Oil Easy	62	10040500	Washer Lock 5/16
16	11050600	Washer Lock Ext Tooth 3/8	72	71070512	Screw Hex Hd Cap 5/16-18 x 3/4
17	17490624	Screw Thdrol 3/8-16 x 1-1/2	81	73510400	Nut Keps Hex 1/4-20 UNC
23	169837	Shield Heat	102	164863	Screw HwHd Hi-Lo #13-16 x 3/4
25	164068	Choke Control			
26	73920600	Nut, Keps 3/8-24 UNF			
29	137180	Kit Spark Arrestor (Flat Scrn)			

NOTE: All component dimensions given in U.S. inches
1 inch = 25.4 mm

REPAIR PARTS

TRACTOR - MODEL NUMBER DPR22H46STB

SEAT ASSEMBLY

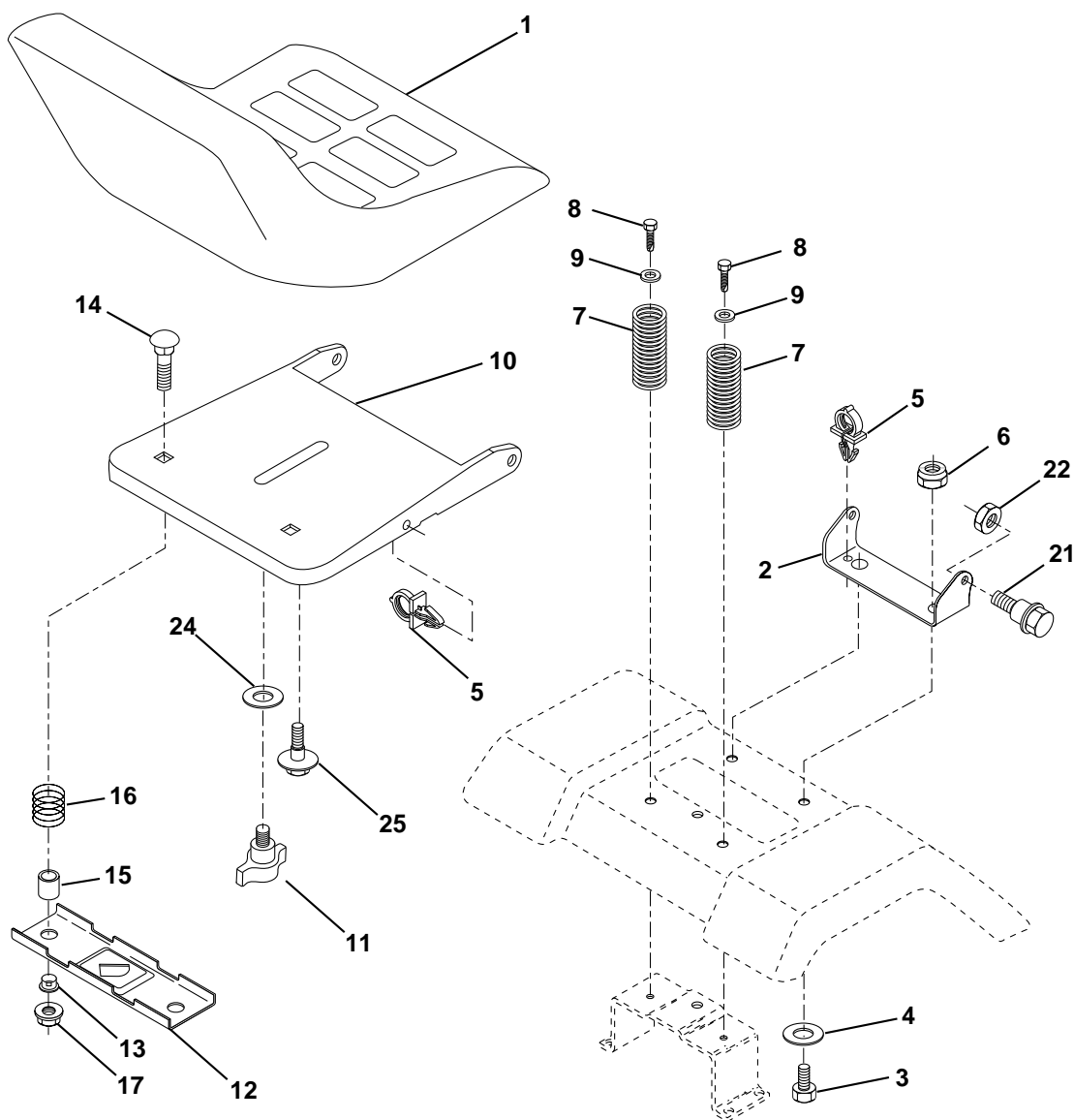

KEY NO.	PART NO.	DESCRIPTION	KEY NO.	PART NO.	DESCRIPTION
1	171684	Seat	13	121248X	Bushing Snap Blk Nyl 50 Id
2	140551	Bracket Pivot Seat 8 720	14	72050412	Bolt Rdhd Sqnk 1/4-20x1-1/2
3	71110616	Bolt Fin Hex 3/8-16 Unc x 1	15	121249X	Spacer Split 28x 88
4	19131610	Washer Flat 13/32 x 1 x 10 Ga.	16	123740X	Spring Cprsn
5	145006	Clip Push-In	17	123976X	Nut Lock 1/4 Lge Flg Gr 5 Zinc
6	73800600	Nut Hex w/Ins. 3/8-16 Unc	21	171852	Bolt Shoulder 5/16-18 Unc
7	124181X	Spring Seat Cprsn 2 250 Blk Zi	22	73800500	Nut Hex Lock W/Ins 5/16-18
8	17000616	Screw 3/8-16 x 1	24	19171912	Washer 17/32 X 1-3/16 X 12 Ga.
9	19131614	Washer 13/32 x 1 x 14 Ga.	25	127018X	Bolt Shoulder 5/16-18 X 62
10	174894	Pan Seat			
11	166369	Knob Seat Adj. Wingnut			
12	121246X	Bracket Mounting Switch			

NOTE: All component dimensions given in U.S. inches.
1 inch = 25.4 mm

REPAIR PARTS

TRACTOR - MODEL NUMBER DPR22H46STB

DECALS

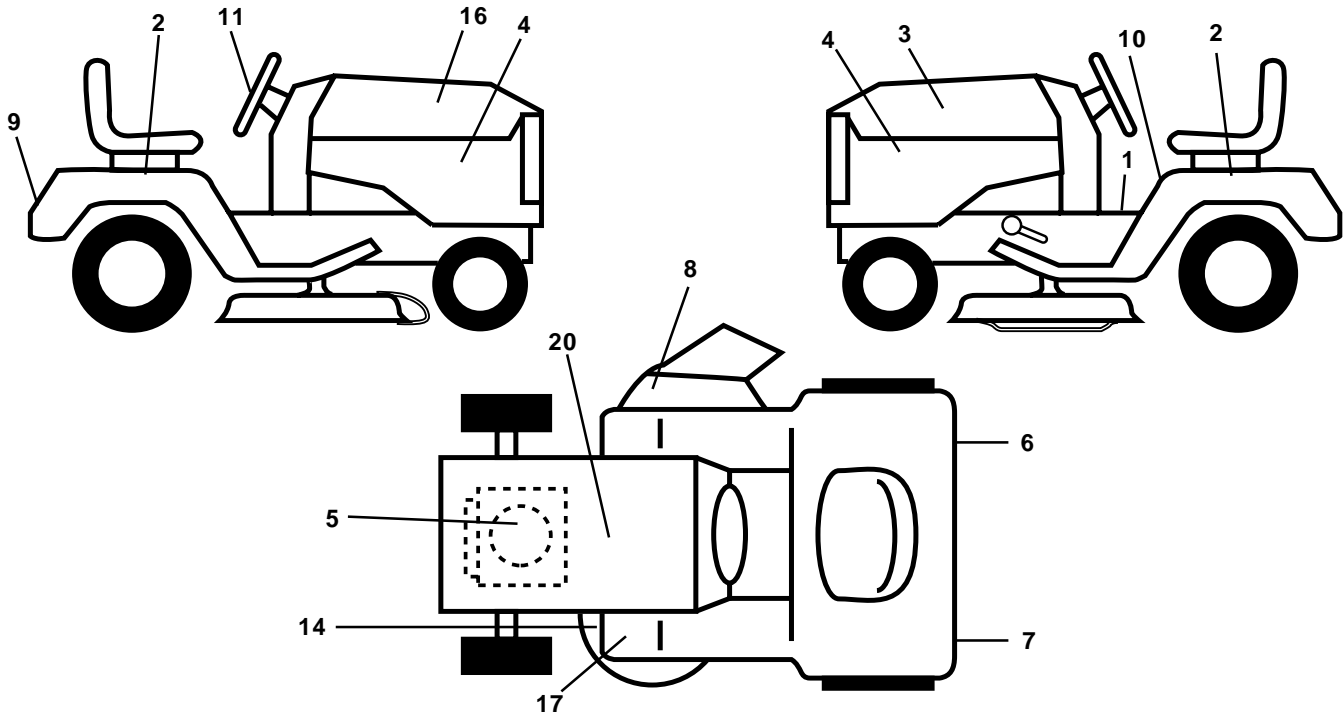

KEY NO.	PART NO.	DESCRIPTION	KEY NO.	PART NO.	DESCRIPTION
1	164095	Decal Dash	11	172743	Decal Ins Strg Whl
2	176303	Decal Fender Auto	14	160397	Decal V-Belt Schematic
3	176273	Decal Hood LH	16	176272	Decal Hood Rh
4	176274	Decal Side Panel	17	164657	Decal Clutch
5	170852	Decal HP Engine	20	145005	Decal Bat Dan/Psn
6	173587	Decal Reflector Rh	--	169210	Decal By Pass Lt Hydro
7	173589	Decal Reflector Lh	--	165800X428	Pad Footrest Lh
8	170563	Decal Warning Mower	--	138311	Decal Handle Lft Height Adjust
9	172740	Decal Fender Logo	--	165799X428	Pad Footrest Rh
10	157140	Decal Fender Danger E/F	--	178249	Manual Owner's (English)
			--	178250	Manual Owner's (French)

WHEELS & TIRES

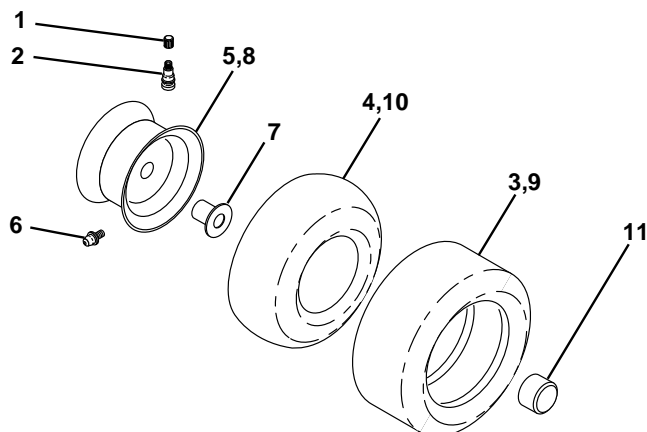

KEY NO.	PART NO.	DESCRIPTION
1	59192	Cap Valve Tire
2	65139	Stem Valve
3	170455	Tire F T 15 X 6 0 - 6 Service
4	59904	Tube Front (Service Item Only)
5	106732X421	Rim Asm 6"front Service
6	278H	Fitting Grease (Front Wheel Only)
7	9040H	Bearing Flange (Front Wheel Only)
8	106108X421	Rim Asm 8"rear Service
9	170456	Tire R T 20x10 -8 C Service
10	7152J	Tube Rear (Service Item Only)
11	104757X428	Cap Axle Blk 1 50 X 1 00
--	144334	Sealant, Tire (10 oz. Tube)

NOTE: All component dimensions given in U.S. inches
1 inch = 25.4 mm

REPAIR PARTS

TRACTOR - MODEL NUMBER DPR22H46STB

MOWER LIFT

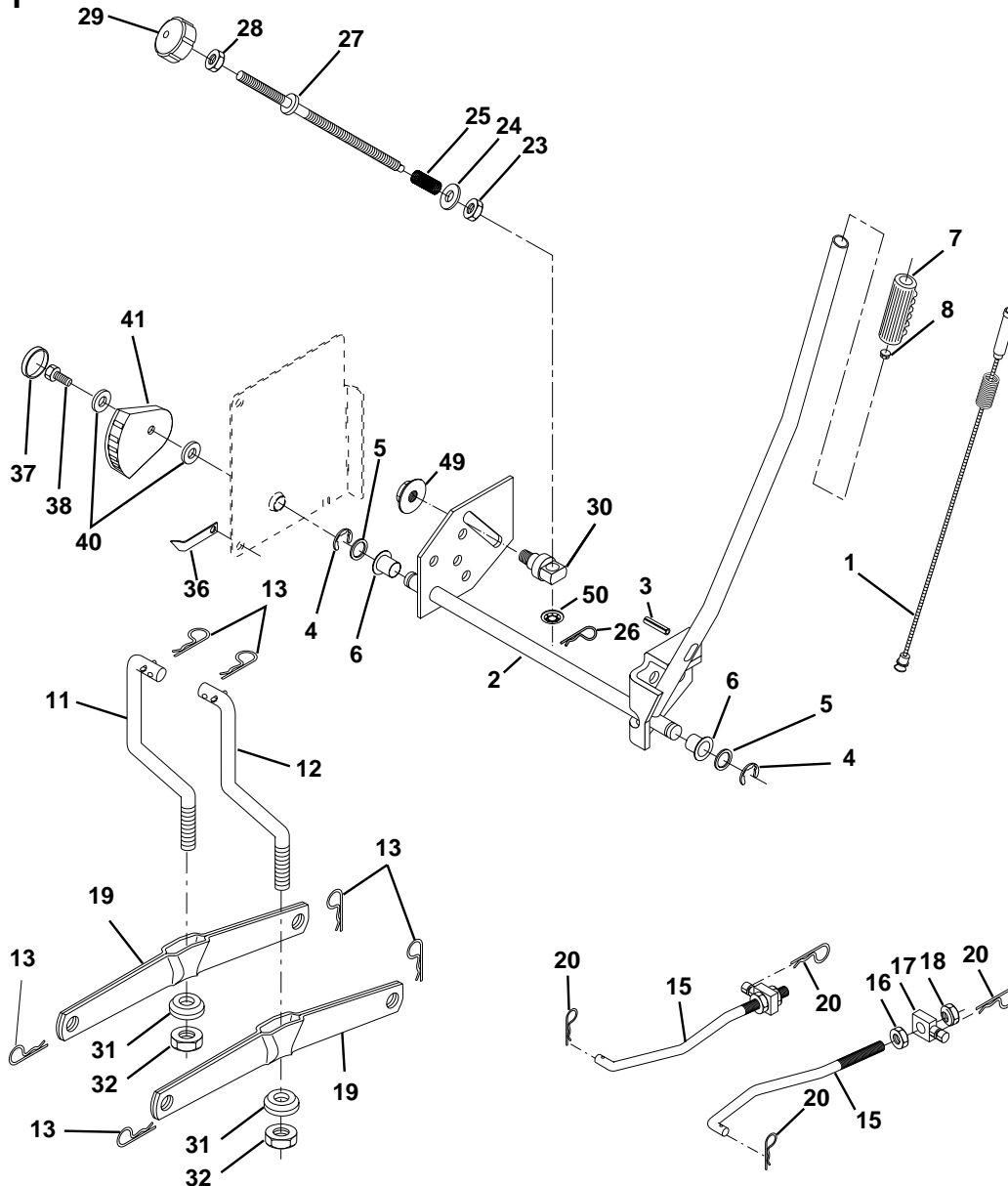

KEY NO.	PART NO.	DESCRIPTION
1	159461	Wire Asm Inner/Sprg W/plunger
2	159476	Shaft Asm Lift RH w/Inf
3	138284	Pin Groove
4	12000002	E Ring #5133-62
5	19211621	Washer 21/32 X 1 X 21 Ga
6	120183X	Bearing Nylon Blk 629 Id
7	125631X	Grip Handle
8	170770	Button Plunger
11	139865	Link Lift LH Fixed Length
12	139866	Link Lift RH Fixed Length
13	4939M	Retainer Spring
15	173288	Link Front
16	73350800	Nut Jam Hex 1/2-13 Unc
17	130171	Trunnion Blk Zinc
18	73800800	Nut Lock w/Wsh 1/2-13unc
19	139868	Arm Suspension Rear
20	163552	Retainer Spring
23	110807X	Nut Special

KEY NO.	PART NO.	DESCRIPTION
24	19131016	Washer 13/32 X 5/8 X 16 Ga
25	164024	Spring
26	169484	Retainer Clip
27	164543	Rod Adj Lift
28	73350600	Nut Hex Jam 3/8-16 Unc
29	138057	Knob Inf 3/8-16 Unc Blk W/sym
30	150233	Trunnion Infin Height
31	169865	Bearing Pvt Lift
32	73540600	Nut Crownlock 3/8 - 24
36	155097	Pointer Height Indicator
37	123935X	Plug Hole Blk 1.485/1.515 Dia.
38	17060516	Screw 5/16-18 x 1
40	19112410	Washer 11/32 x 1-1/2 10 Ga.
41	155098	Indicator Height STLT
49	145212	Nut Hex Flange Lock
50	110452X	Nut PUsh Phos & Oil

NOTE: All component dimensions given in U.S. inches
1 inch = 25.4 mm

REPAIR PARTS

TRACTOR - MODEL NUMBER DPR22H46STB

MOWER DECK

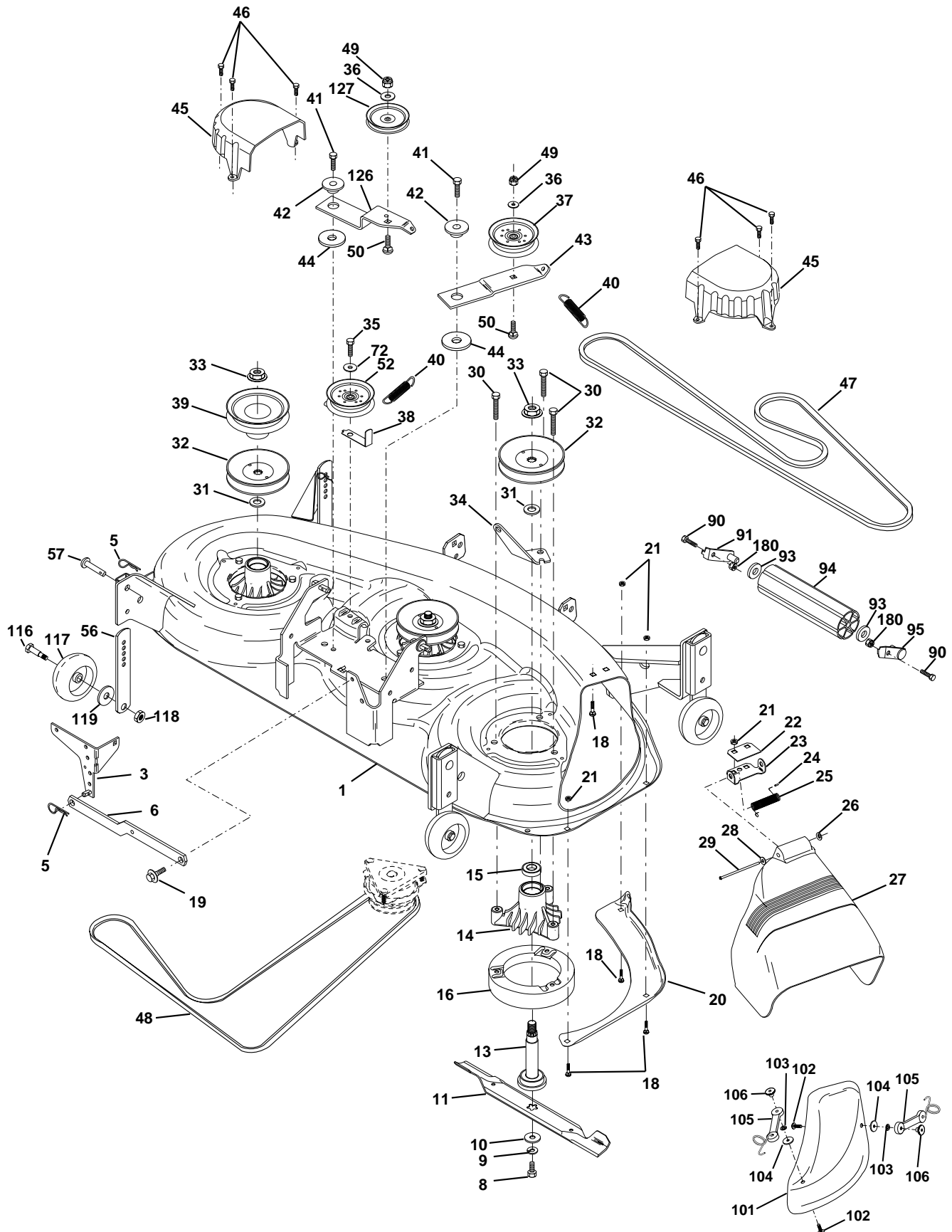

REPAIR PARTS**TRACTOR - MODEL NUMBER DPR22H46STB****MOWER DECK**

KEY NO.	PART NO.	DESCRIPTION	KEY NO.	PART NO.	DESCRIPTION
1	156833X421	Deck Asm., Mower 46"	44	133943	Washer, Hardened
3	138457	Bracket Asm., Sway Bar	45	145059	Cover, Mandrel Deck
5	4939M	Retainer Spring	46	137729	Screw, Thdroll. 1/4-20 x 5/8
6	130832	Arm, Suspension, Rear (Sway Bar)	47	144959	V-Belt, Mower, Secondary
8	850857	Bolt, Patched 3/8-24 x 1-1/4 Gr. 8	48	148763	V-Belt, Mower, Primary
9	10030600	Washer, Lock Hvy., Unplated 3/8	49	73680600	Nut, Crownlock 3/8-16 UNC
10	140296	Washer, Hard Blade, Mower Vented	50	72110612	Bolt, Carriage 3/8-16 x 1-1/2 Gr. 5
11	176084	Blade, 46" Hi Perf	52	173901	Pulley Idler 46 Pri. Drive
--	152443	Blade, 46" Mulching	53	19131312	Washer 13/32 x 13/16 x 12
13	137553	Shaft Asm. w/Lower Bearing	54	74780616	Bolt Fin Hex 3/8-16 x 1
14	137152	Housing, Mandrel	55	72140608	Bolt Rdhd 3/8-16 x 1
15	110485X	Bearing, Ball, Mandrel	56	155986	Bar Adjusting Gage wheel
16	174493	Stripper, Mower Round	57	156941	Pin Head Rivet
18	72140505	Bolt, Carriage 5/16-18 x 5/8	72	19131616	Washer 13/32 x 1 x 16 Ga.
19	132827	Bolt, Hex Head, Shoulder 5/16-18	91	175746	Bracket, Asm Noseroller, LH
20	145055	Baffle, Vortex Mower 46"	92	73800600	Nut, Lock, Hex w/Ins 3/8-16UNC
21	73680500	Nut, Crownlock 5/16-18 UNC	93	19171416	Washer 17/32 x 7/8 x 16 Ga.
22	134753X421	Stiffener, Bracket	94	132264	Roller, Nose 38 & 42
23	131267X421	Bracket, Deflector	95	175747	Bracket, asm Noseroller RH
24	105304X	Cap, Sleeve	101	145579	Cover Mulcher 46" Black
25	149287	Spring, Torsion, Deflector	102	71081010	Screw Phillips Truss Head
26	110452X	Nut, Push	103	10071000	Washer Lock #10
27	166883X428	Shield, Deflector Mower	104	19061216	Washer #10
28	19111016	Washer 11/32 x 5/8 x 16 Ga.	105	160793	Latch Asm mulch/Bagger
29	131491	Rod, Hinge	106	2029J	Nut Weld
30	157722	Screw, WshHead, Thdroll	116	137644	Bolt, Shoulder
31	129963	Washer, Spacer Mower Vented	117	133957	Gauge Wheel
32	173434	Pulley, Mandrel	118	73930600	Nut, Centerlock 3/8-16 UNC
33	137266	Nut, Flg. Top Lock Cntr. 9/16	119	19121414	Washer 3/8 x 7/8 x 14 Ga.
34	144945X421	Anchor, Spring Deck 46"	126	144948X421	Arm, Idler, Primary Deck 46"
35	17490628	Screw, Thdroll 3/8-16 x 1-3/4 Tytt	127	173902	Pulley, Idler, V-Groove Dim. 4.25
36	19131316	Washer 13/32 x 13/16 x 16 Ga.	--	143651	Mandrel Assembly (Includes Key Nos. 8-10, 13-15, 31 and 33)
37	173438	Pulley, Idler, Flat	--	173559	Mower Serv 46" (Standard Deck Order nose roller, guage wheels, and mulch plate separately)
38	173900	Keeper, Belt, Idler			
39	173899	Pulley, Idler, Driven			
40	137273	Spring, Secondary 44/46/50 Vent			
41	17060620	Screw 3/8-16 x 1-1/4			
42	122052X	Spacer, Retainer			
43	144949X421	Arm, Idler Secondary			

NOTE: All component dimensions given in U.S. inches
1 inch = 25.4 mm