

# OPERATOR'S MANUAL

# **TROY-BILT**<sup>®</sup>

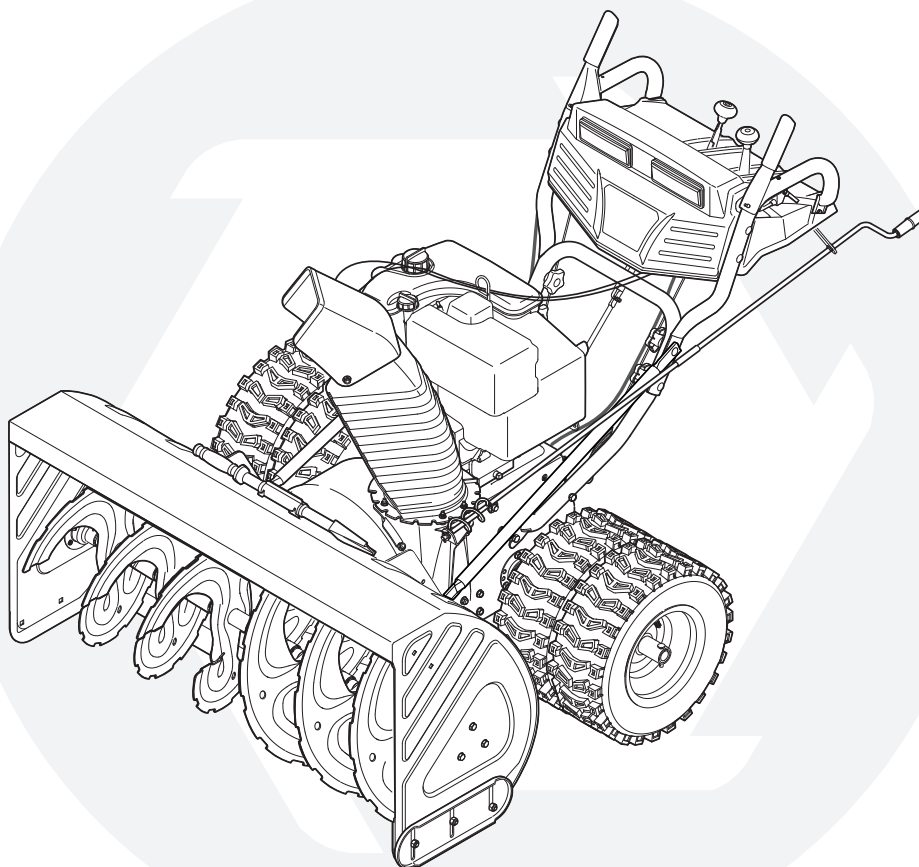

## Two-Stage Snow Thrower – Storm 13045

### 31AH9Q77766

### IMPORTANT

#### READ SAFETY RULES AND INSTRUCTIONS CAREFULLY BEFORE OPERATION

**Warning:** This unit is equipped with an internal combustion engine and should not be used on or near any unimproved forest-covered, brush-covered or grass-covered land unless the engine's exhaust system is equipped with a spark arrester meeting applicable local or state laws (if any). If a spark arrester is used, it should be maintained in effective working order by the operator. In the State of California the above is required by law (Section 4442 of the California Public Resources Code). Other states may have similar laws. Federal laws apply on federal lands. A spark arrester for the muffler is available through your nearest engine authorized service dealer or contact the service department, P.O. Box 361131 Cleveland, Ohio 44136-0019.

This Operator's Manual is an important part of your new snow thrower. It will help you assemble, prepare and maintain the unit for best performance. Please read and understand what it says.

## Table of Contents

Customer Support.....	2	Maintaining Your Snow Thrower.....	16
Safety Labels .....	3	Off-Season Storage .....	22
Safe Operation Practices.....	4	Troubleshooting.....	23
Setting Up Your Snow Thrower.....	6	Illustrated Parts List.....	24
Operating Your Snow Thrower.....	10	Warranty .....	31
Making Adjustments .....	14		

Specifications are subject to change without notification or obligation. Images may not reflect your exact model and are for reference purposes only.

## Finding and Recording Model Number

**BEFORE ASSEMBLING YOUR NEW EQUIPMENT:**  
Please locate the model plate on the equipment and copy the information to the sample model plate provided to the right. You can locate the model plate by standing at the operating position and looking down at the rear of the snow thrower. This information will be necessary to use the manufacturer's web site, when contacting the Customer Service Department, or when obtaining assistance from an authorized Troy-Bilt service dealer.

**TROY-BILT**<sup>®</sup>  
www.troybilt.com  
TROY-BILT LLC  
P. O. BOX 361131  
CLEVELAND, OH 44136  
330-558-7220  
866-840-6483

## Customer Support

**Please do not return the unit to the retailer from which it was purchased, without first contacting Customer Support.**

If you have difficulty assembling this product or have any questions regarding the controls, operation, or maintenance of this unit, you can seek help from the experts. Choose from the options below:

- Visit [www.troybilt.com](http://www.troybilt.com) for many useful suggestions. Click the Tool Bench tab to access the Troy-Bilt Solution Center.
- Call a Customer Support Representative at 1-866-840-6483.
- The engine manufacturer is responsible for all engine-related issues with regard to performance, power-rating, specifications, warranty, and service. Please refer to the engine manufacturer's Owner's/Operator's Manual, packed separately with your unit, for more information.

**TROY-BILT**  
**PRODUCT & SERVICE SOLUTIONS**

<div style="text-align: center; margin-bottom: 10px;"></div> <p><b>Customer Service</b> Find answers to all your Troy-Bilt questions. Visit our customer service.</p> <p style="text-align: center;">▶ Get Answers</p>	<div style="text-align: center; margin-bottom: 10px;"></div> <p><b>Product Registration</b> A convenient way to register your Troy-Bilt products and be entered to win!</p> <p style="text-align: center;">▶ Register Today</p>		
<p><b>Maintenance Schedules</b> Prolong the life of your Troy-Bilt Tractor. <b>COMING SOON!</b></p>	<p><b>Parts &amp; Accessories</b> Get more out of your Troy-Bilt products and find parts.</p> <p style="text-align: center;"><a href="#">View Parts and Accessories</a></p>	<p><b>Owner's Manuals</b> Can't find your owner's manuals? Find it and download it now!</p> <p style="text-align: center;"><a href="#">View Owner's Manuals</a></p>	<p><b>Flask Modules</b> Watch the experts use product and perform service! <b>COMING SOON!</b></p>

**⚠ DANGER**

1. KEEP AWAY FROM ROTATING IMPELLER AND AUGER. CONTACT WITH IMPELLER OR AUGER CAN AMPUTATE HANDS AND FEET.
2. USE CLEAN-OUT TOOL TO UNCLOG DISCHARGE CHUTE.
3. DISENGAGE CLUTCH LEVERS, STOP ENGINE, AND REMAIN BEHIND HANDLES UNTIL ALL MOVING PARTS HAVE STOPPED BEFORE UNCLOGGING OR SERVICING MACHINE.
4. TO AVOID THROWN OBJECTS INJURIES, NEVER DIRECT DISCHARGE AT BYSTANDERS. USE EXTRA CAUTION WHEN OPERATING ON GRAVEL SURFACES.
5. READ OPERATOR'S MANUAL.

CLEAN-OUT TOOL 

**⚠ DANGER**



**AVOID INJURY FROM ROTATING AUGER - KEEP HANDS, FEET AND CLOTHING AWAY.**

**⚠ DANGER**



- NEVER PUT HAND IN CHUTE. CONTACT WITH ROTATING PARTS CAN AMPUTATE FINGERS AND HANDS.
- SHUT OFF ENGINE AND WAIT UNTIL ALL MOVING PARTS HAVE STOPPED BEFORE UNCLOGGING.
- USE CLEAN-OUT TOOL OR WOODEN STICK TO UNCLOG DISCHARGE CHUTE.

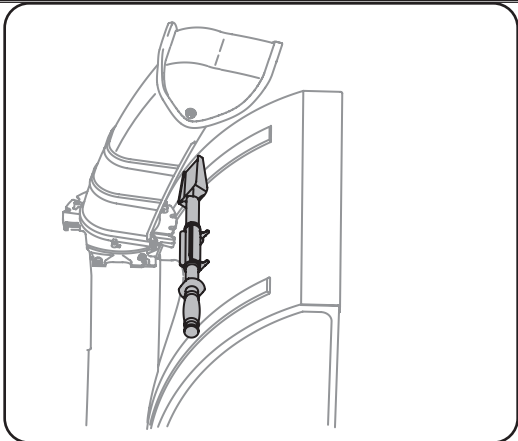

A chute clean-out tool is fastened to the top of the auger housing with a mounting clip. The tool is designed to clear a chute assembly of ice and snow. This item is fastened with a cable tie at the factory. Cut the cable tie before operating the snow thrower.



**WARNING: Never use your hands to clear a clogged chute assembly. Shut off engine and remain behind handles until all moving parts have stopped before using the clean-out tool to clear the chute assembly.**

# 1

## Safety Labels



### WARNING

This symbol points out important safety instructions which, if not followed, could endanger the personal safety and/or property of yourself and others. Read and follow all instructions in this manual before attempting to operate this machine. Failure to comply with these instructions may result in personal injury. When you see this symbol.

#### HEED ITS WARNING!

#### Your Responsibility

Restrict the use of this power machine to persons who read, understand and follow the warnings and instructions in this manual and on the machine.

2

## Safe Operation Practices



### WARNING

This symbol points out important safety instructions which, if not followed, could endanger the personal safety and/or property of yourself and others. Read and follow all instructions in this manual before attempting to operate this machine. Failure to comply with these instructions may result in personal injury. When you see this symbol.

#### HEED ITS WARNING!

#### Your Responsibility

Restrict the use of this power machine to persons who read, understand and follow the warnings and instructions in this manual and on the machine.



**WARNING:** Engine Exhaust, some of its constituents, and certain vehicle components contain or emit chemicals known to State of California to cause cancer and birth defects or other reproductive harm.

**DANGER:** This machine was built to be operated according to the rules for safe operation in this manual. As with any type of power equipment, carelessness or error on the part of the operator can result in serious injury. This machine is capable of amputating hands and feet and throwing objects. Failure to observe the following safety instructions could result in serious injury or death.

### Training

1. Read, understand, and follow all instructions on the machine and in the manual(s) before attempting to assemble and operate. Keep this manual in a safe place for future and regular reference and for ordering replacement parts.
2. Be familiar with all controls and their proper operation. Know how to stop the machine and disengage them quickly.
3. Never allow children under 14 years old to operate this machine. Children 14 years old and over should read and understand the operation instructions and safety rules in this manual and should be trained and supervised by a parent.
4. Never allow adults to operate this machine without proper instruction.
5. Thrown objects can cause serious personal injury. Plan your snow-throwing pattern to avoid discharge of material toward roads, bystanders and the like.
6. Keep bystanders, helpers, pets and children at least 75 feet from the machine while it is in operation. Stop machine if anyone enters the area.
7. Exercise caution to avoid slipping or falling, especially when operating in reverse.

### Preparation

1. Thoroughly inspect the area where the equipment is to be used. Remove all doormats, newspapers, sleds, boards, wires and other foreign objects, which could be tripped over or thrown by the auger/impeller.
2. Always wear safety glasses or eye shields during operation and while performing an adjustment or repair to protect your eyes. Thrown objects which ricochet can cause serious injury to the eyes.
3. Do not operate without wearing adequate winter outer garments. Do not wear jewelry, long scarves or other loose clothing, which could become entangled in moving parts. Wear footwear which will improve footing on slippery surfaces.
4. Use a grounded three-wire extension cord and receptacle for all units with electric start engines.
5. Adjust collector housing height to clear gravel or crushed rock surfaces.
6. Disengage all control levers before starting the engine.
7. Never attempt to make any adjustments while engine is running, except where specifically recommended in the operator's manual.
8. Let engine and machine adjust to outdoor temperature before starting to clear snow.
9. To avoid personal injury or property damage use extreme care in handling gasoline. Gasoline is extremely flammable and the vapors are explosive. Serious personal injury can occur when gasoline is spilled on yourself or your clothes, which can ignite. Wash your skin and change clothes immediately.
  - a. Use only an approved gasoline container.
  - b. Extinguish all cigarettes, cigars, pipes and other sources of ignition.
  - c. Never fuel machine indoors.
  - d. Never remove gas cap or add fuel while the engine is hot or running.
  - e. Allow engine to cool at least two minutes before refueling.
  - f. Never over fill fuel tank. Fill tank to no more than ½ inch below bottom of filler neck to provide space for fuel expansion.
  - g. Replace gasoline cap and tighten securely.
  - h. If gasoline is spilled, wipe it off the engine and equipment. Move machine to another area. Wait 5 minutes before starting the engine.
  - i. Never store the machine or fuel container inside where there is an open flame, spark or pilot light (e.g. furnace, water heater, space heater, clothes dryer etc.).
  - j. Allow machine to cool at least 5 minutes before storing.



## Operation

1. Do not put hands or feet near rotating parts, in the auger/impeller housing or chute assembly. Contact with the rotating parts can amputate hands and feet.
2. The auger/impeller control lever is a safety device. Never bypass its operation. Doing so makes the machine unsafe and may cause personal injury.
3. The control levers must operate easily in both directions and automatically return to the disengaged position when released.
4. Never operate with a missing or damaged chute assembly. Keep all safety devices in place and working.
5. Never run an engine indoors or in a poorly ventilated area. Engine exhaust contains carbon monoxide, an odorless and deadly gas.
6. Do not operate machine while under the influence of alcohol or drugs.
7. Muffler and engine become hot and can cause a burn. Do not touch.
8. Exercise extreme caution when operating on or crossing gravel surfaces. Stay alert for hidden hazards or traffic.
9. Exercise caution when changing direction and while operating on slopes.
10. Plan your snow-throwing pattern to avoid discharge towards windows, walls, cars etc. Thus, avoiding possible property damage or personal injury caused by a ricochet.
11. Never direct discharge at children, bystanders and pets or allow anyone in front of the machine.
12. Do not overload machine capacity by attempting to clear snow at too fast of a rate.
13. Never operate this machine without good visibility or light. Always be sure of your footing and keep a firm hold on the handles. Walk, never run.
14. Disengage power to the auger/impeller when transporting or not in use.
15. Never operate machine at high transport speeds on slippery surfaces. Look down and behind and use care when backing up.
16. If the machine should start to vibrate abnormally, stop the engine, disconnect the spark plug wire and ground it against the engine. Inspect thoroughly for damage. Repair any damage before starting and operating.
17. Disengage all control levers and stop engine before you leave the operating position (behind the handles). Wait until the auger/impeller comes to a complete stop before unclogging the chute assembly, making any adjustments, or inspections.
18. Never put your hand in the discharge or collector openings. Always use the clean-out tool provided to unclog the discharge opening. Do not unclog chute assembly while engine is running. Shut off engine and remain behind handles until all moving parts have stopped before unclogging.
19. Use only attachments and accessories approved by the manufacturer (e.g. wheel weights, tire chains, cabs etc.).
20. If situations occur which are not covered in this manual, use care and good judgment. Contact your dealer for assistance.

## Maintenance & Storage

1. Never tamper with safety devices. Check their proper operation regularly. Refer to the maintenance and adjustment sections of this manual.
2. Before cleaning, repairing, or inspecting machine disengage all control levers and stop the engine. Wait until the auger/impeller come to a complete stop. Disconnect the spark plug wire and ground against the engine to prevent unintended starting.
3. Check bolts and screws for proper tightness at frequent intervals to keep the machine in safe working condition. Also, visually inspect machine for any damage.
4. Do not change the engine governor setting or over-speed the engine. The governor controls the maximum safe operating speed of the engine.
5. Snow thrower shave plates and skid shoes are subject to wear and damage. For your safety protection, frequently check all components and replace with original equipment manufacturer's (OEM) parts only. "Use of parts which do not meet the original equipment specifications may lead to improper performance and compromise safety!"
6. Check controls periodically to verify they engage and disengage properly and adjust, if necessary. Refer to the adjustment section in this operator's manual for instructions.
7. Maintain or replace safety and instruction labels, as necessary.
8. Observe proper disposal laws and regulations for gas, oil, etc. to protect the environment.
9. Prior to storing, run machine a few minutes to clear snow from machine and prevent freeze up of auger/impeller.
10. Never store the machine or fuel container inside where there is an open flame, spark or pilot light such as a water heater, furnace, clothes dryer etc.
11. Always refer to the operator's manual for proper instructions on off-season storage.

### Do not modify engine

To avoid serious injury or death, do not modify engine in any way. Tampering with the governor setting can lead to a runaway engine and cause it to operate at unsafe speeds. Never tamper with factory setting of engine governor.

### Notice regarding Emissions

Engines which are certified to comply with California and federal EPA emission regulations for SORE (Small Off Road Equipment) are certified to operate on regular unleaded gasoline, and may include the following emission control systems: Engine Modification (EM) and Three Way Catalyst (TWC) if so equipped.

### Your Responsibility

Restrict the use of this power machine to persons who read, understand and follow the warnings and instructions in this manual and on the machine.

# 2

## Safe Operation Practices



### WARNING

This symbol points out important safety instructions, which if not followed, could endanger the personal safety and/or property of yourself and others. Read and follow all instructions in this manual before attempting to operate this machine. Failure to comply with these instructions may result in personal injury. When you see this symbol.

### HEED IT'S WARNING!

### Your Responsibility

Restrict the use of this power machine to persons who read, understand and follow the warnings and instructions in this manual and on the machine.

# 3

## Setting Up Your Snow Thrower



**NOTE:** All references in this manual to the left or right side of the snow thrower is from the operating position only. Exceptions, if any, will be specified.

### IMPORTANT

This unit is shipped with the engine full of oil. After assembly, refer to the Tecumseh Engines manual packed separately with your snow thrower for fuel and oil fill-up details.

Specifications are subject to change without notification or obligation. Images may not reflect your exact model and are for reference purposes only.

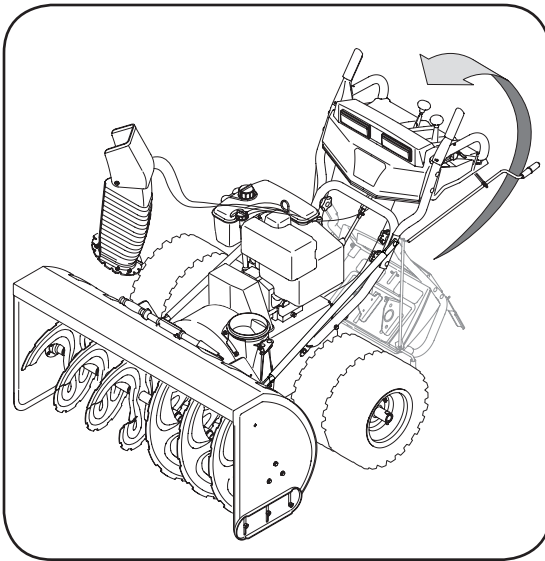

Figure 3-1

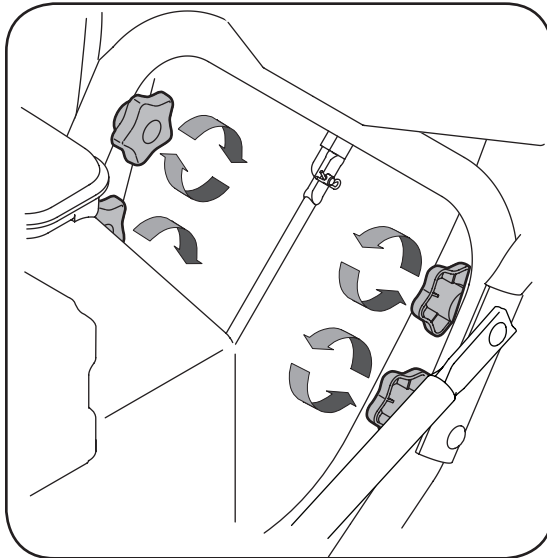

Figure 3-2

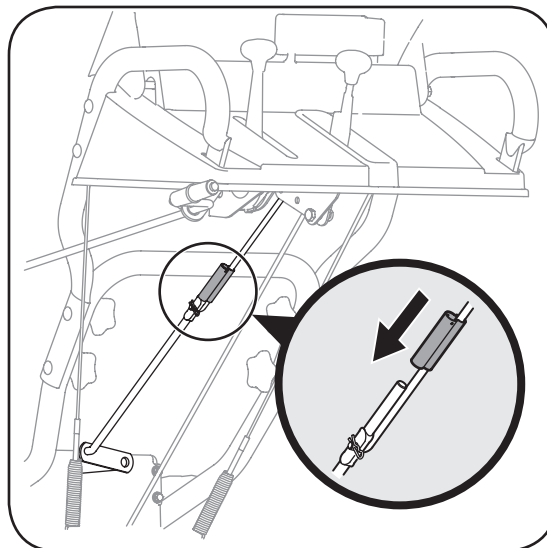

Figure 3-3

**IMPORTANT:** Two replacement auger shear pins are included with this manual. Refer to the Maintenance section for more information regarding shear pin replacement.

**NOTE:** All references in this manual to the left or right side of the snow thrower is from the operating position only. Exceptions, if any, will be specified.

**IMPORTANT:** This unit is shipped with the engine full of oil. After assembly, refer to the Tecumseh Engine manual packed separately with your snow thrower for fuel and oil fill-up details.

1. Observe the lower area of the snow thrower to be sure that all cables (steering, auger, and drive) are properly routed and not pinched or kinked before pivoting handle upward.
  - a. Remove the lower star knob and carriage bolt from each side of the lower handle. Pull up and back on upper handle as shown in Figure 3-1. Align upper handle with the lower handle. Make certain the springs at the lower end of the auger and drive cables are securely hooked into their respective actuator bracket.
2.
  - a. Secure the upper handle and lower handle with the two star knobs and carriage bolts removed earlier. See Figure 3-2.
  - b. Tighten the two star knobs already installed in the upper holes to firmly secure the upper handle and support tubes.
3. Align the upper and lower shift rods, then slide the shift rod connector down over the end of the lower shift rod. Tap the connector until the lower rod is completely through the connector. See Figure 3-3.

**NOTE:** If the connector is not properly assembled, the shift rod will pivot and you will not be able to change speeds or direction.

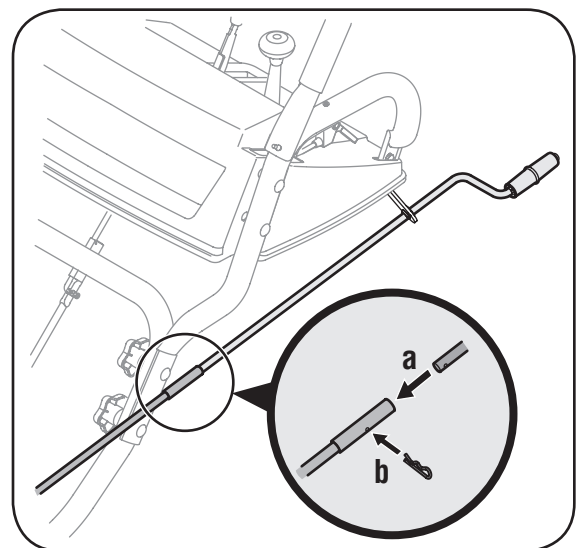

Figure 3-4

**NOTE:** If the full range of speeds (forward and reverse) can not be achieved, refer to the "Making Adjustments" section.

4. a. Remove the internal cotter pin from the upper chute crank. Slide the upper chute crank into the sleeve on the lower chute crank.  
b. Align the hole in the upper chute crank with the hole in the sleeve (If necessary, use a pair of pliers to assist in aligning holes). Insert the internal cotter pin through the holes to secure the chute crank. See Figure 3-4.
5. Remove lock nuts and screws securing one of the flange keepers to the chute assembly.
6. Place chute assembly onto chute base as shown in Figure 3-5, making sure that the notches engage with the spiral end of chute directional control.
7. Secure flange keeper removed earlier with lock nuts and screws. Tighten down nuts securing the other two flange keepers. See Figure 3-6.
8. If not already done, slip the cables that run from the handle panel to the discharge chute into the cable guide located on top of the engine.
9. If not already done, wrap the wire of the head lamp wire harness down the right handle until the wire can be plugged into the engine alternator wire connector down on the engine. See Figure 3-8.
10. Normally the cable ties holding the steering cables against the handle are loosely installed on each side of the lower handle at the factory. Pull the cable ties tight to secure. Cut the excess from the ends of cable ties.

The extension cord is fastened with a cable tie to the rear of the auger housing for shipping purposes. Cut the cable tie and remove it before operating the snow thrower.

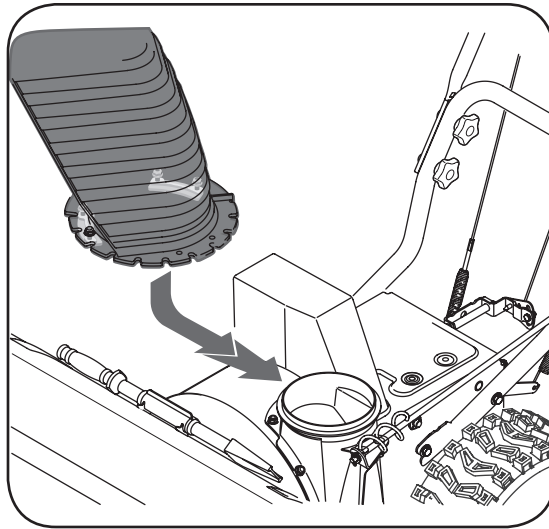

Figure 3-5

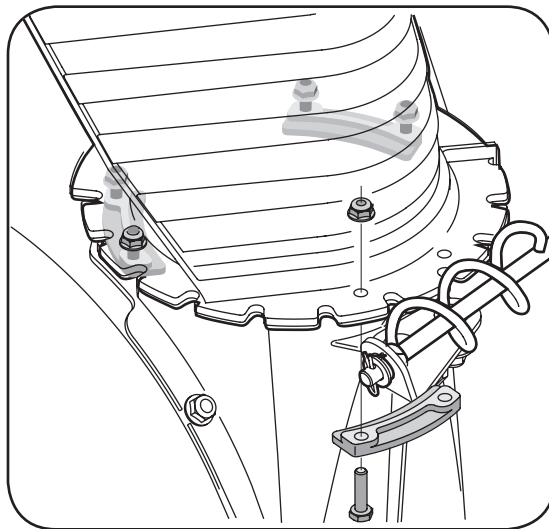

Figure 3-6

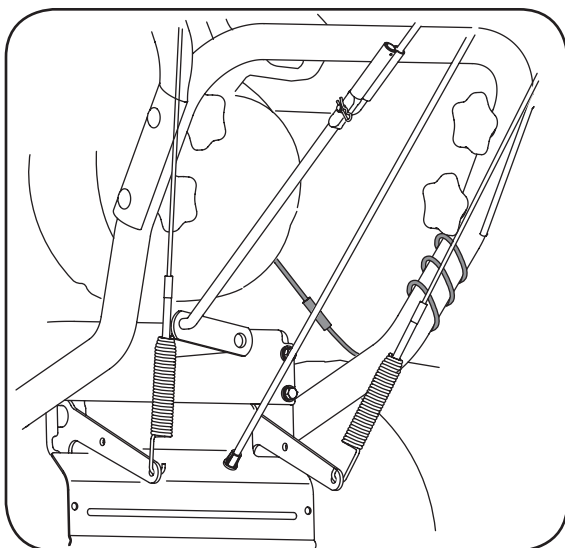

Figure 3-8

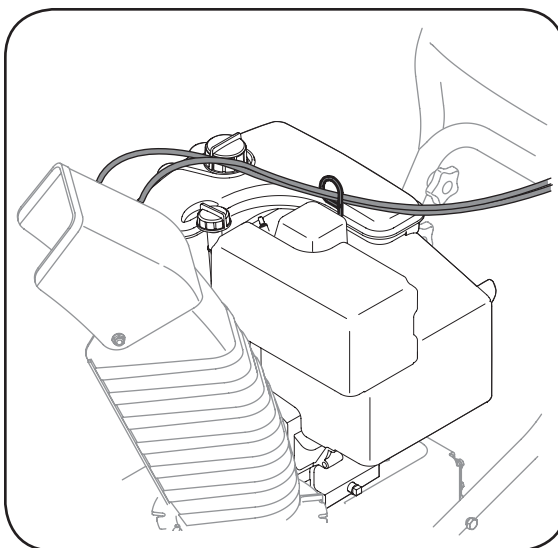

Figure 3-7

# 3

## Setting Up Your Snow Thrower



### IMPORTANT

Prior to operating your snow thrower, refer to Auger Control Test in the Operation section. Read and follow all instructions carefully and perform all adjustments to verify your snow thrower is operating safely and properly.

# 3

## Setting Up Your Snow Thrower



Specifications are subject to change without notification or obligation. Images may not reflect your exact model and are for reference purposes only.

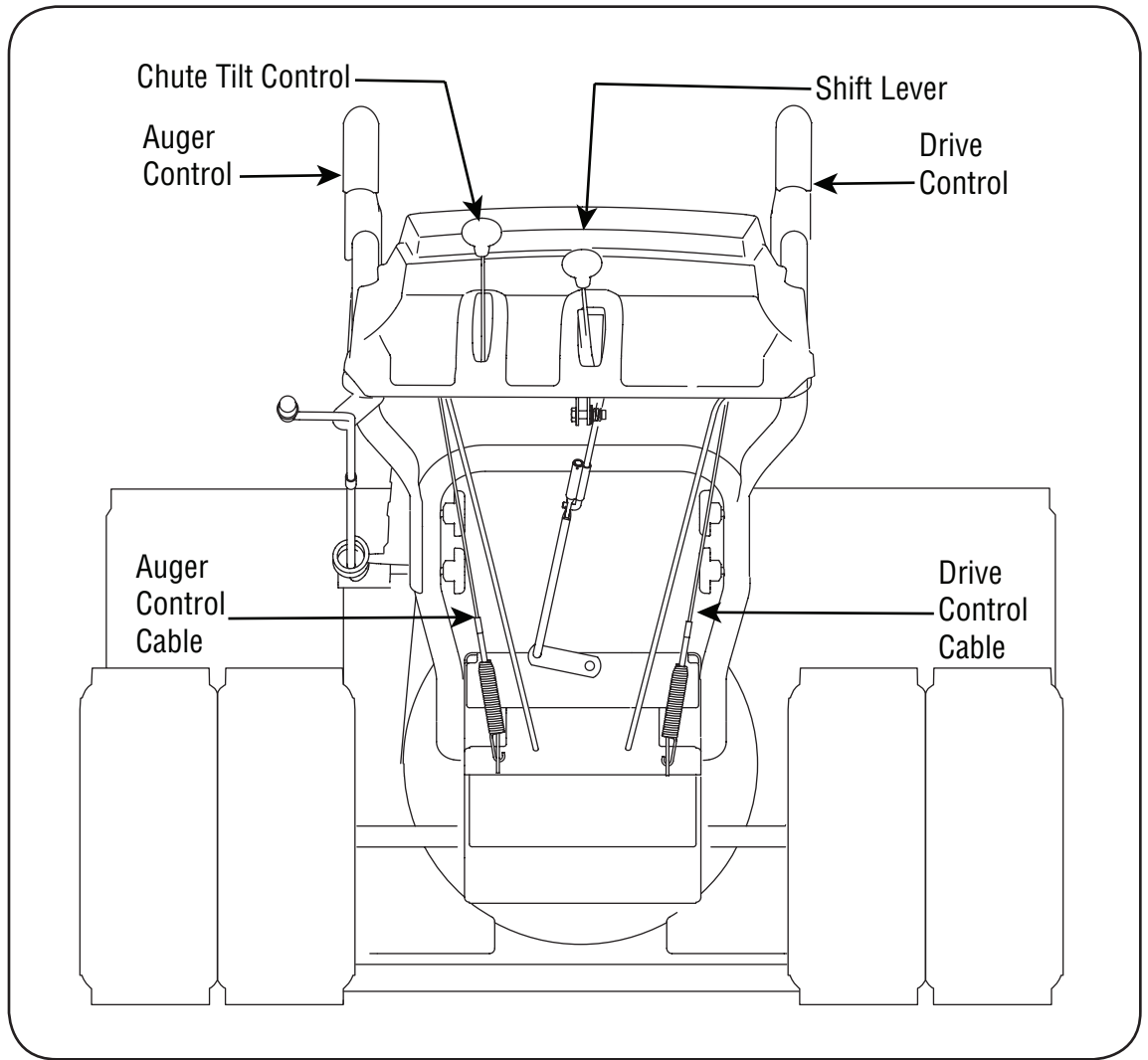

Figure 3-9

### Final Adjustments

Make these final assembly adjustments **before** operating your snow thrower for the first time. Failure to follow these instructions may cause damage to the snow thrower.

### Testing Drive Control & Shift Lever

Refer to Figure 3-9 for location of controls.

1. Move the shift lever into sixth (6) position.
2. With the wheel drive control released, push the snow thrower forward, then pull it back. The machine should move freely.
3. Engage the drive control and attempt to move the machine both forward and back, resistance should be felt.
4. Move the shift lever into the fast reverse (R2) position and repeat the previous two steps.

If you experienced resistance rolling the unit, either when repositioning the shift lever from 6 to R2 or when attempting to move the machine with the drive control released, adjust the drive control immediately. See Adjusting Drive and Auger Controls.

### Testing Auger Drive Control

When the auger control is released and in the disengaged "up" position, the cable should have very little slack, but should NOT be tight.

1. In a well-ventilated area, start the snow thrower engine as instructed in the Operation section. Make sure the throttle is set in the fast position.
2. While standing in the operator's position (behind the snow thrower), engage the auger control and allow the auger to remain engaged for approximately ten seconds before releasing the auger control. Repeat this several times.
3. With the engine running in the fast position and the auger control in the disengaged "up" position, walk to the front of the machine.

Confirm that the auger has completely stopped rotating and shows no signs of motion.

4. If the auger shows any signs of rotating, immediately return to the operator's position and shut off the engine. Wait for all moving parts to stop before readjusting the auger control cable.



### Adjusting Drive and Auger Controls

1. From beneath the handle, pull downward on the appropriate cable and unhook the spring found on the end of the cable from its respective actuator bracket. Refer to Figures 3-9 and 3-10.
2. Slide the spring up the cable to expose the cable coupler threads and lock nut. Refer to Figure 3-11.

Adjust the lock nut as follows:

3. If adjusting the drive cable, thread the lock nut outward (down the coupler) to lengthen the cable and allow the unit to move freely when the control is released. Thread the lock nut inward (up the coupler) to shorten the cable to reduce slippage and prevent the machine from being easily moved with the drive control engaged.
4. If adjusting the auger cable, thread the lock nut down to lengthen the cable as necessary to stop the auger from turning when the control is released.

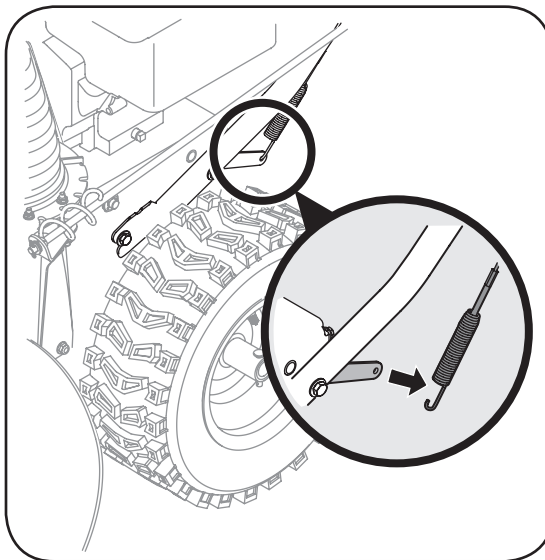

Figure 3-10



**WARNING:** Do not over-tighten the cable. Over-tightening may prevent the auger from disengaging and compromise the safety of the snow thrower.

5. Reattach the spring to the actuator bracket.
6. Repeat the wheel drive and auger control tests to verify proper adjustment. Repeat previous steps if necessary to attain proper adjustment of each cable.

### Tire Pressure (Pneumatic Tires)

The tires are over-inflated for shipping purposes. Check the tire pressure before operating the snow thrower. Refer to the tire side wall for tire manufacturer's recommended psi and deflate (or inflate) the tires as necessary.

**NOTE:** If the tire pressure is not equal in both tires, the unit may pull to one side or the other and the shave plate will not sit level on the ground.

**IMPORTANT:** Under any circumstance do not exceed manufacturer's recommended psi. Equal tire pressure should be maintained at all times. Excessive pressure when seating beads may cause tire/rim assembly to burst with force sufficient to cause serious injury. Refer to sidewall of tire for recommended pressure.

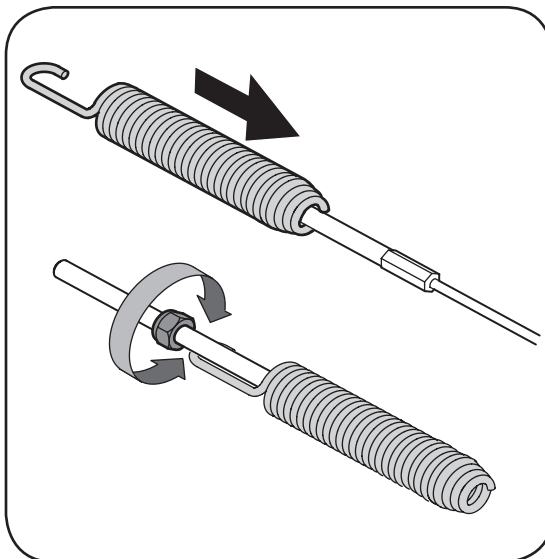

Figure 3-11

3

## Setting Up Your Snow Thrower



### WARNING

Do not over-tighten the cable. Over-tightening may prevent the auger from disengaging and compromise the safety of the snow thrower.



**IMPORTANT:** Under any circumstance do not exceed manufacturer's recommended psi. Equal tire pressure should be maintained at all times. Excessive pressure when seating beads may cause tire/rim assembly to burst with force sufficient to cause serious injury. Refer to sidewall of tire for recommended pressure.

Specifications are subject to change without notification or obligation. Images may not reflect your exact model and are for reference purposes only.



# Know Your Snow Thrower

# 4

## Operating Your Snow Thrower



### WARNING

Read, understand, and follow all instructions and warnings on the machine and in this manual before operating.



For detailed starting instructions and more information on all engine controls, refer to the Tecumseh Engine manual packed separately.

Specifications are subject to change without notification or obligation. Images may not reflect your exact model and are for reference purposes only.

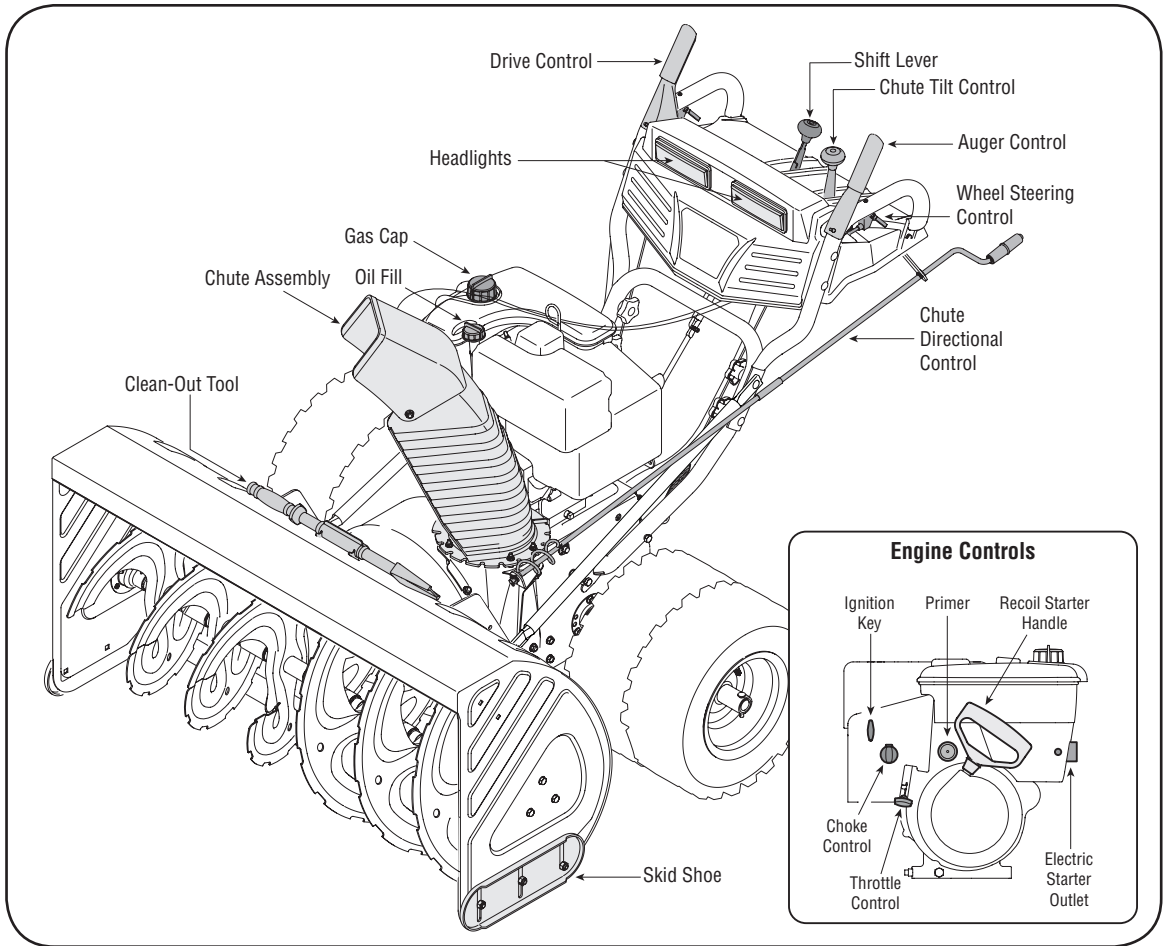

Figure 4-1

Now that you have setup your snow thrower, it's important to become acquainted with its controls and features.

**NOTE:** For detailed starting instructions and more information on all engine controls, refer to the *Tecumseh Engines manual* packed separately and **Starting The Engine** later in this section.

### Shift Lever

The shift lever is located in the center of the handle panel. Place the shift lever into any of eight positions to control the direction of travel and ground speed.

#### Forward

Your snow thrower has six forward (F) speeds, with position number one (1) being the slowest speed.

#### Reverse

Your snow thrower has two reverse (R) speeds, with position number one (1) being the slower speed.

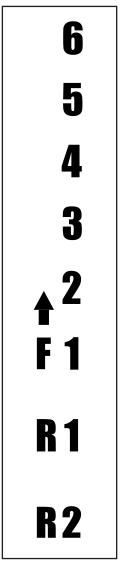

### Choke Control

The choke control is found on the rear of the engine and is activated by rotating the knob clockwise. Activating the choke control closes the choke plate on the carburetor and aids in starting the engine.



### Throttle Control

The throttle control is located on the engine. It regulates the speed of the engine and will shut off the engine when pushed down completely.



### Primer

Depressing the primer forces fuel directly into the engine's carburetor to aid in cold-weather starting.

### Oil Fill

Engine oil level can be checked and oil added through the oil fill.



### Auger Control

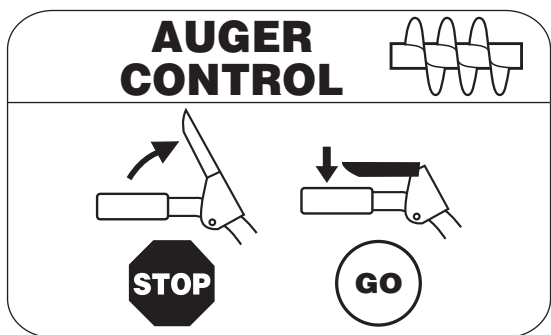

The auger control is located on the left handle. Squeeze the control grip against the handle to engage the augers and start snow throwing action. Release to stop.

### Drive Control / Auger Lock

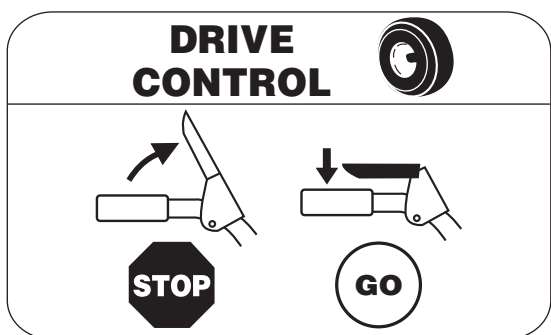

The drive control is located on the right handle. Squeeze the control grip against the handle to engage the wheel drive. Release to stop.

The drive control also locks the auger control so you can operate the chute directional control without interrupting the snow throwing process. If the auger control is engaged simultaneously with the drive control, the operator can release the auger control (on the left handle) and the augers will remain engaged. Release both controls to stop the augers and wheel drive.

**IMPORTANT:** Always release the drive control before changing speeds.

### Chute Tilt Control

The distance snow is thrown can be changed by adjusting the angle of the chute assembly. Move the chute tilt control forward to decrease the distance, toward the rear to increase.

### Chute Directional Control

The chute directional control is located on the left side of the snow thrower.

- To change the **direction** in which snow is thrown, crank clockwise to discharge to the left and counter-clockwise to discharge to the right.

### Wheel Steering Controls

The left and right wheel steering controls are located on the underside of the handles. Squeeze the right control to turn right; squeeze the left control to turn left.

**NOTE:** Operate the snow thrower in open areas until you are familiar with these controls.

### Ignition Key

The ignition key must be inserted and snapped in place in order for the engine to start. Remove the ignition key to prevent unauthorized use of equipment. Do NOT attempt to turn the key.

### Clean-Out Tool

The clean-out tool is mounted to the rear of the auger housing and is designed to clear a clogged chute. Refer to **Using Clean-Out Tool** later in this section for instructions on how to properly use it.



**WARNING:** Never use your hands to clear a clogged chute assembly. Shut off engine and remain behind handles until all moving parts have stopped before unclogging.

**NOTE:** The clean-out tool is fastened to the rear of the auger housing with a cable tie. Cut the cable tie before operating the snow thrower.

### Skid Shoes

Position the skid shoes based on surface conditions. Adjust upward for hard-packed snow. Adjust downward when operating on gravel or crushed rock surfaces.

4

## Operating Your Snow Thrower



### WARNING

The operation of any snow thrower can result in foreign objects being thrown into the eyes, which can damage your eyes severely. Always wear safety glasses while operating the snow thrower, or while performing any adjustments or repairs on it.

Be sure no one other than the operator is standing near the snow thrower while starting engine or operating snow thrower. Never run engine indoors or in enclosed, poorly ventilated areas. Engine exhaust contains carbon monoxide, an odorless and deadly gas. Keep hands, feet, hair and loose clothing away from any moving parts on engine and snow thrower.

# 4

## Operating Your Snow Thrower



### WARNING

Use extreme care when handling gasoline. Gasoline is extremely flammable and the vapors are explosive. Never fuel the machine indoors or while the engine is hot or running. Extinguish cigarettes, cigars, pipes and other sources of ignition.

The electric starter is equipped with a grounded three-wire power cord and plug and is designed to operate on 120 volt AC household current. It must be used with a properly grounded three-prong receptacle at all times to avoid the possibility of electric shock. Follow all instructions carefully prior to operating the electric starter.

### Gas & Oil Fill-Up

Service the engine with gasoline and oil as instructed in the Tecumseh Engines manual packed separately with your snow thrower. Read instructions carefully.



**WARNING:** Use extreme care when handling gasoline. Gasoline is extremely flammable and the vapors are explosive. Never fuel machine indoors or while the engine is hot or running. Extinguish cigarettes, cigars, pipes and other sources of ignition.

### Starting the Engine

1. Attach spark plug wire to spark plug. Make certain the metal loop on the end of the spark plug wire (inside the rubber boot) is fastened securely over the metal tip on the spark plug.
2. Make certain both the auger control and drive control are in the disengaged (released) position.
3. Move throttle control up to FAST position. Insert ignition key into slot. Make sure it snaps into place. Do not attempt to turn the key.

**NOTE:** The engine cannot start unless the key is inserted into ignition switch. Do not turn the key.

### Electric Starter

1. Determine that your home's wiring is a three-wire grounded system. Ask a licensed electrician if you are not certain.



**WARNING:** The optional electric starter is equipped with a grounded three-wire power cord and plug, and is designed to operate on 120 volt AC household current. It must be used with a properly grounded three-prong receptacle at all times to avoid the possibility of electric shock. Follow all instructions carefully prior to operating the electric starter.

If your house wiring system is not a three-wire grounded system, do not use this electric starter under any conditions.

If your home electrical system is grounded, but a three-hole receptacle is not available, one should be installed by a licensed electrician before using the electric starter.

If you have a grounded three-prong receptacle, proceed as follows:

1. Plug the extension cord into the outlet located on the engine's surface. Plug the other end of extension cord into a three-prong 120-volt, grounded, AC outlet in a well-ventilated area.
2. Rotate choke control to FULL choke position (for a cold engine start).

**NOTE:** If the engine is already warm, place choke control in the OFF position instead of FULL.

3. Push the primer two or three times for cold engine start, making sure to cover vent hole in the center of the primer when pushing.

**NOTE:** DO NOT use primer to restart a warm engine after a short shutdown.

4. Push starter button to start engine.
5. Once the engine starts, immediately release starter button.
6. As the engine warms, slowly rotate the choke control to the OFF position. If the engine falters, quickly rotate the choke control back to FULL and then slowly into the OFF position again.
7. When disconnecting the extension cord, always unplug the end at the three-prong wall outlet before unplugging the opposite end from the snow thrower.

### Recoil Starter

1. Rotate choke control to FULL choke position (cold engine start).

**NOTE:** If the engine is already warm, place choke control in the OFF position instead of FULL.

2. Push the primer two or three times for cold engine start, making sure to cover vent hole in the center of the primer when pushing.

**NOTE:** DO NOT use primer to restart a warm engine after a short shutdown.

**NOTE:** Additional priming may be necessary if the temperature is below 15° Fahrenheit.

3. Grasp the recoil starter handle and slowly pull the rope out. At the point where it becomes slightly harder to pull the rope, slowly allow the rope to recoil.
4. Pull the starter handle with a firm, rapid stroke. Do not release the handle and allow it to snap back. Keep a firm hold on the starter handle and allow it to slowly recoil.

5. As the engine warms, slowly rotate the choke control to the OFF position. If the engine falters, quickly rotate the choke control back to the FULL position and then slowly into the OFF position again.

**NOTE:** Allow the engine to warm up for a few minutes after starting. The engine will not develop full power until it reaches operating temperatures.

## Stopping the Engine

Run engine for a few minutes before stopping to help dry off any moisture on the engine.

1. Move throttle control to STOP position.
2. Remove the ignition key (do not turn key) to prevent unauthorized use of equipment.
3. Wipe all snow and moisture from the area around the engine as well as the area in and around the drive control and auger control. Also, engage and release both controls several times.

**NOTE:** Keep the key in a safe place. The engine cannot start without the ignition key.

## To Engage Drive

1. With the engine running near top speed, move shift lever to one of six FORWARD positions or two REVERSE positions. Select a speed appropriate for the snow conditions that exist.

**NOTE:** Use slower speeds in higher snow and/or until you are familiar with the snow thrower operation.

2. Squeeze drive control against the right handle and the snow thrower will move. Release it and the drive motion will stop.

**IMPORTANT:** NEVER move the shift lever without first releasing the wheel drive control. Doing so will cause premature wear on the drive system's friction wheel.

3. To turn the unit left or right, squeeze the respective wheel steering control. See Figure 4-1.

## To Engage Augers

1. To engage augers and start snow throwing, squeeze the left hand auger control against the left handle. Release to stop augers.
2. While the auger control is engaged, squeeze the drive control to move, release to stop. Do not shift speeds while the drive is engaged.

**NOTE:** This same lever also locks auger control so you can turn the chute control without interrupting the snow throwing process.

3. Release the auger control; the interlock mechanism should keep the auger control engaged until the drive control is released.
4. Release the drive control to stop both the augers and the wheel drive. To stop the auger, both levers must be released.

## Operating Tips

**NOTE:** Allow the engine to warm up for a few minutes. The engine will not develop full power until it reaches operating temperature.



**WARNING:** The temperature of the muffler and the surrounding areas may exceed 150° F. Avoid these areas.

- If possible, remove snow immediately after it falls.
- Discharge snow downwind whenever possible.
- Slightly overlap each previous path.
- Set the skid shoes 1/4-inch below the shave plate for normal usage. Adjust them upward for hard-packed snow and downward when using on gravel or crushed rock.

## Chute Clean-Out Tool

The chute clean-out tool is conveniently fastened to the rear of the auger housing with a mounting clip. Should snow and ice become lodged in the chute assembly during operation, proceed as follows to safely clean the chute assembly and chute opening:

1. Release both the Auger Control and the Drive Control.
2. Stop the engine by removing the ignition key.
3. Remove the clean-out tool from the clip which secures it to the rear of the auger housing. See Figure 4-1.
4. Use the shovel-shaped end of the clean-out tool to dislodge and scoop any snow and ice which has formed in and near the chute assembly.
5. Refasten the clean-out tool to the mounting clip on the rear of the auger housing, reinsert the ignition key, and start the snow thrower's engine.
6. While standing in the operator's position (behind the snow thrower), engage the auger control for a few seconds to clear any remaining snow and ice from the chute assembly.

4

## Operating Your Snow Thrower



### WARNING

The muffler, engine, and surrounding areas become hot and can cause a burn. Do not touch.



**NOTE:** Use slower speeds in higher snow and/or until you are familiar with the snow thrower operation.

**IMPORTANT**  
NEVER move the shift lever without first releasing the wheel drive control. Doing so will cause premature wear on the drive system's friction wheel.



# 5

## Making Adjustments



### WARNING

Read, understand, and follow all instructions and warnings on the machine and in this manual before operating.

Never attempt to make any adjustments while the engine is running, except where specified in operator's manual.



Specifications are subject to change without notification or obligation. Images may not reflect your exact model and are for reference purposes only.

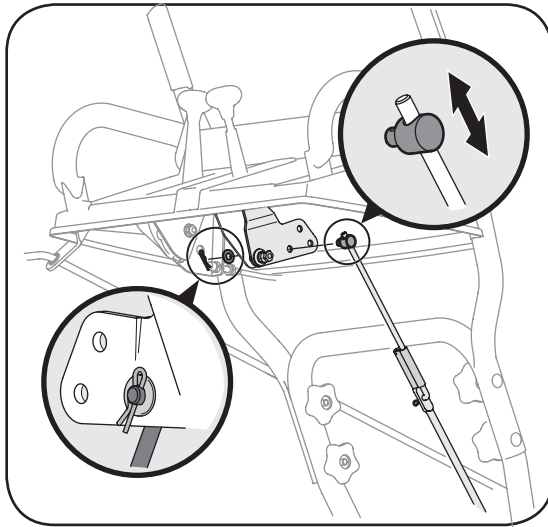

Figure 5-1

### Shift Rod

If the full range of speeds (forward and reverse) cannot be achieved, refer to the figure above and adjust the shift rod as follows:

1. Looking underneath the handle panel, note which of the three holes in the shift lever the ferrule is inserted into. Also note the direction of insertion. Remove the internal cotter pin and flat washer from the ferrule and withdraw the ferrule from the shift lever. See Figure 5-1.
2. Place shift lever in sixth (6) position or fastest forward speed.
3. Push shift rod and shift arm assembly down sharply as far as it will go to put the drive into the fastest forward position.
4. As necessary, rotate (thread) the ferrule up or down the shift rod until the ferrule lines up with the hole from which it was earlier removed. See Figure 5-1.

5. From the direction noted earlier, insert the ferrule into the proper hole.
6. Reinstall the washer and the internal cotter pin.

### Chute Control

The distance snow is thrown can be adjusted by adjusting the angle of the chute assembly. Refer to "Operating Your Snow Thrower" for instructions.

The remote chute control cables have been pre-adjusted at the factory. Move the remote chute lever on the control panel back and forward to adjust angle of the chute assembly.

### Drive Control

Refer to the Final Adjustment section of the Assembly instructions to adjust the drive control. To further check the adjustment, proceed as follows:

1. With the snow thrower tipped forward (be certain to drain gasoline or place plastic film under the gas cap if the snow thrower has already been operated), remove the frame cover underneath the snow thrower by removing the self-tapping screws. See Figure 5-2.
2. Locate the opening between the axle support bracket and the front frame support (See Figure 5-3). Looking through this opening, with the drive control released, there must be 1/8" clearance between the friction wheel and the drive plate in all positions of the shift lever.
3. With the drive control engaged, the friction wheel must contact the drive plate. See Figure 5-3.
4. If there is no friction wheel clearance, or the friction wheel does not solidly contact the drive plate, re-adjust the lock nut on the lower end of the drive cable following the instructions in the Assembly section.
5. Reassemble the frame cover.

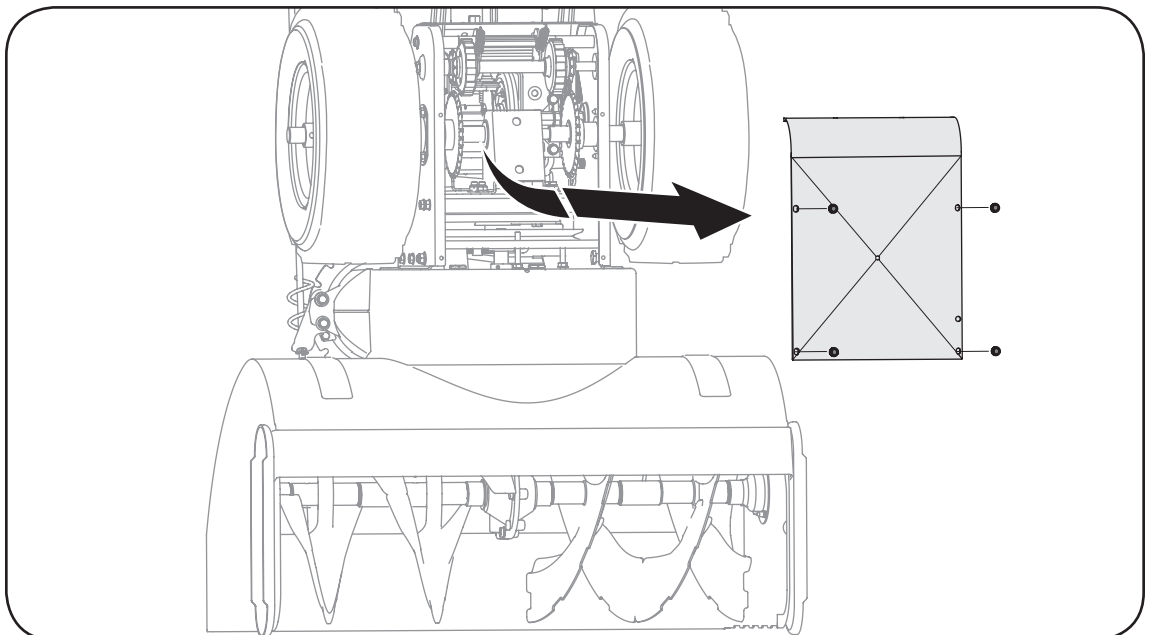

Figure 5-2



**NOTE:** If you placed plastic film under the gas cap earlier, remove it now.

## Skid Shoes

The space between the shave plate and the ground can be adjusted. For close snow removal, place skid shoes in the low position. Use a middle or high position when area to be cleared is uneven.

1. Adjust skid shoes by loosening the six lock nuts and carriage bolts, and moving skid shoes to desired position. See Figure 5-4.
2. Make certain the entire bottom surface of skid shoes are against the ground to avoid uneven wear on the skid shoes.
3. Tighten nuts and bolts securely.

## Chute Bracket Adjustment

If the spiral at the bottom of the chute directional control is not fully engaging with the chute assembly, the chute bracket can be adjusted. To do so:

1. Loosen the two nuts which secure the chute bracket and reposition it slightly. See Figure 5-5.
2. Retighten the nuts.

## Auger Control

To adjust the auger control, refer to the section in this manual titled "Setting Up Your Snow Thrower".

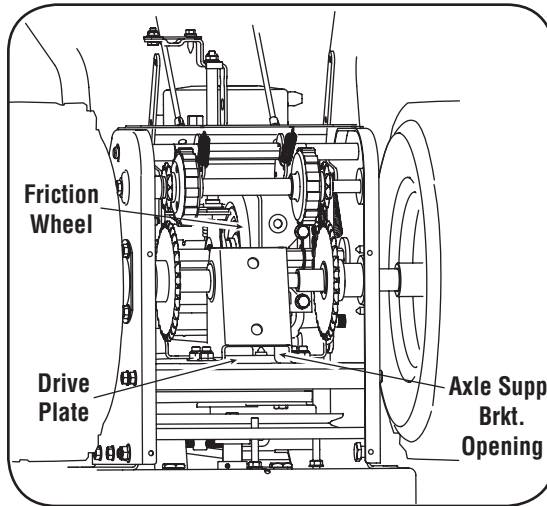

Figure 5-3

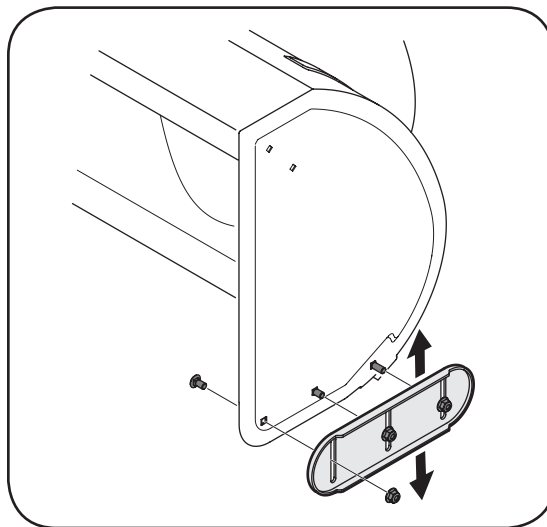

Figure 5-4

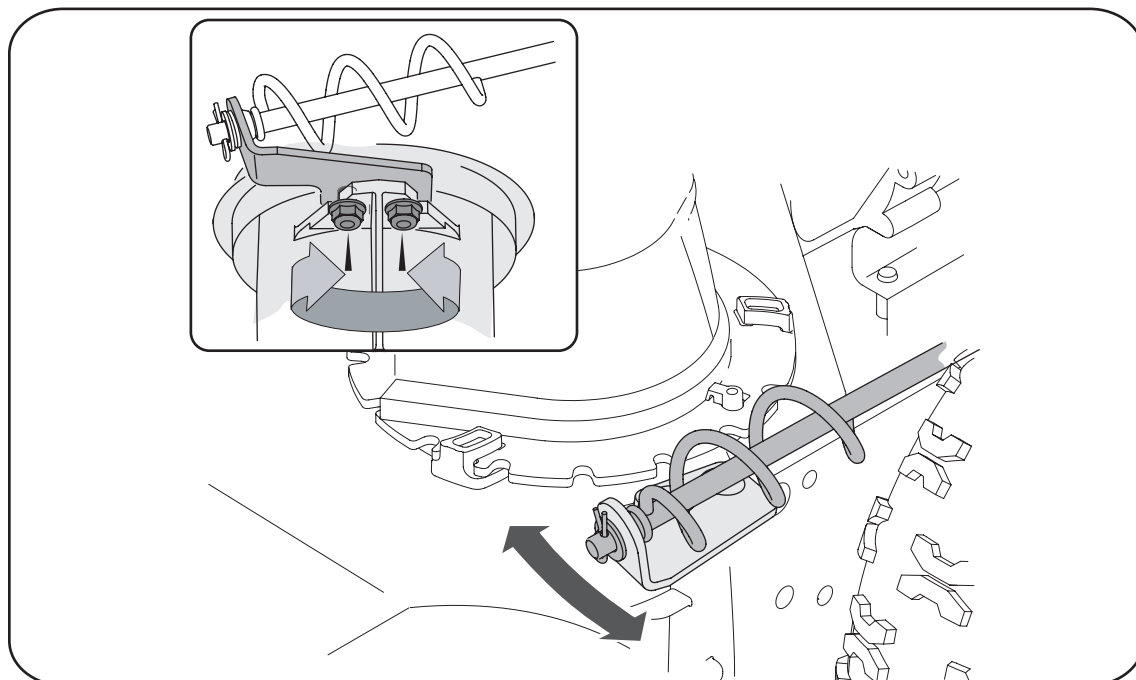

Figure 5-5

# 5

## Making Adjustments



**IMPORTANT:** It is not recommended that you operate this snow thrower on gravel as loose gravel can be easily picked up and thrown by the auger causing personal injury or damage to the snow thrower.

If for some reason, you have to operate the snow thrower on gravel, keep the skid shoe in the highest position for maximum clearance between the ground and the shave plate.

Specifications are subject to change without notification or obligation. Images may not reflect your exact model and are for reference purposes only.

# 6

## Maintaining Your Snow Thrower



### WARNING

Always stop engine, disconnect spark plug, and ground against engine before performing any type of maintenance on your machine.



### IMPORTANT

Avoid oil spillage on rubber friction wheel and aluminum drive plate.

### IMPORTANT

NEVER replace the auger shear pins with standard pins. Any damage to the auger gearbox or other components, as a result of doing so, will NOT be covered by your snow thrower's warranty.

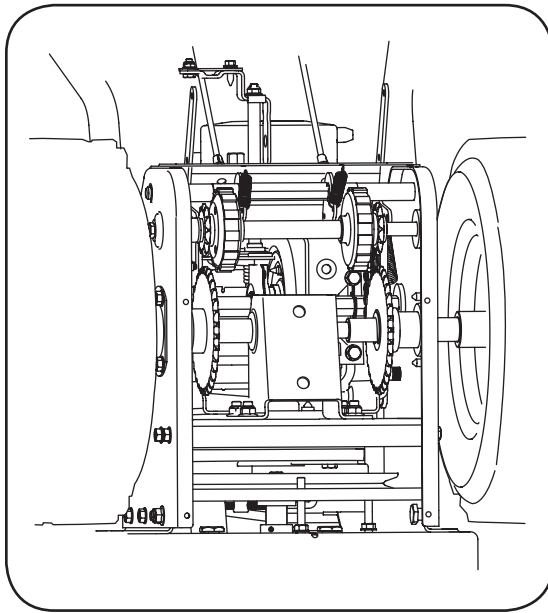

Figure 6-1

### Drive and Shifting Mechanism

At least once a season or after every 25 hours of operation, remove rear cover. Lubricate all chains, sprockets, gears, bearings, shafts, and the shifting mechanism. Use engine oil or a spray lubricant. Refer to Figure 6-1.

**IMPORTANT:** Keep all grease and oil off the rubber friction wheel and drive plate.

### Wheels

At least once a season, remove all wheels. Clean and coat the axles with a multipurpose automotive grease before reinstalling wheels.

### Chute Directional Control

Once a season, the spiral end on the chute directional control should be greased with multipurpose automotive grease.

### Auger Shaft

At least once a season, remove the shear pins on auger shaft. Spray lubricant inside shaft, around the spacers. Also lubricate the flange bearings found at either end of the shaft. See Figure 6-2.

## Engine

Refer to the separate *Tecumseh* Engines manual packed with your unit for all engine maintenance instructions.

## Lubrication

### Engine

Refer to the separate *Tecumseh* Engines manual packed with your unit for all engine lubrication instructions.

## Augers

The augers are secured to the spiral shaft with shear pins and cotter pins. See Figure 6-2. If you hit a foreign object or ice jam, the snow thrower is designed so that the pins will shear.

1. If augers do not turn, check to see if pins have sheared.
2. Replace the pins if needed. Two replacement shear pins and cotter pins have been provided with the snow thrower. Spray an oil lubricant into shaft before inserting new pins and securing with new cotter pins.

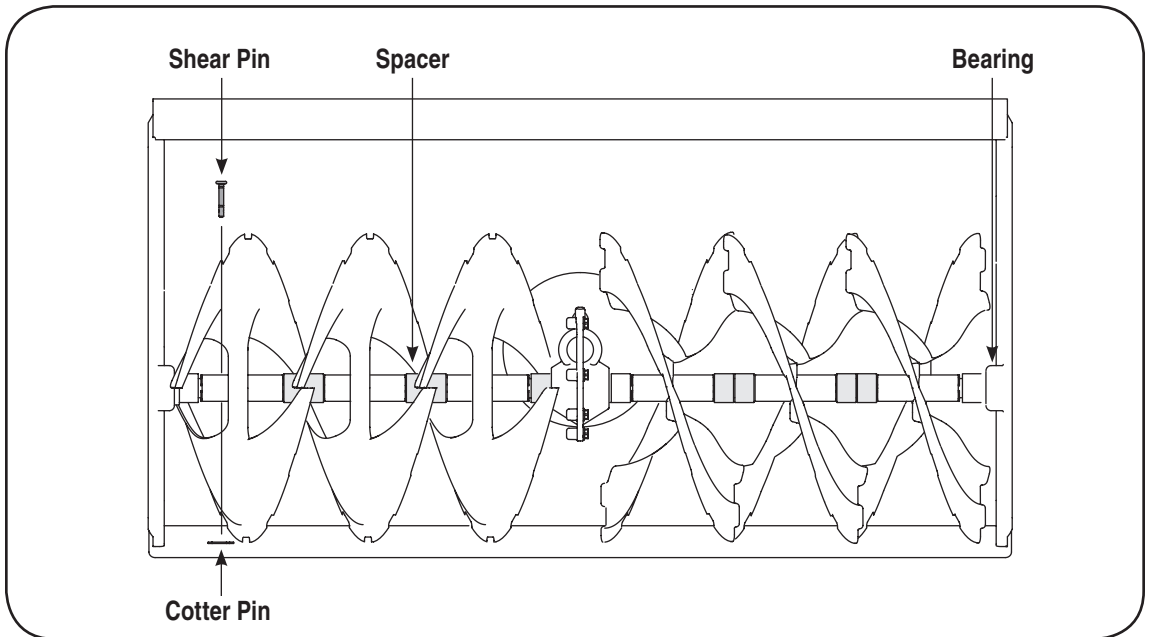

Figure 6-2

## Shave Plate and Skid Shoes

The shave plate and skid shoes on the bottom of the snow thrower are subject to wear. Check these periodically and replace as necessary.

### Skid Shoes

**NOTE:** The skid shoes on this machine have two wear edges. When one side wears out, they can be rotated 180° to use the other edge.

1. Remove the six carriage bolts and lock nuts that secure the two skid shoes to the sides of the auger housing. Refer to Figure 6-3.
2. Position the new skid shoes and secure with the carriage bolts and nuts. Make certain the skid shoes are adjusted to be level.

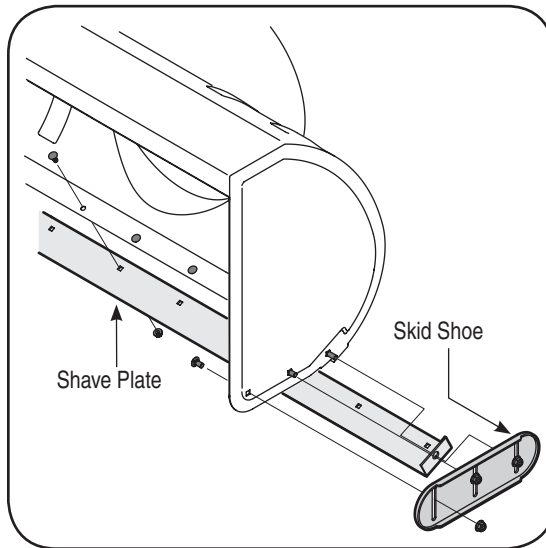

Figure 6-3

### Shave Plate

1. Remove the nuts and carriage bolts that secure the shave plate to the bottom of the housing, Figure 6-3.
2. Remove the rear most hex nut and carriage bolt securing the back of each skid shoe to the sides of the housing. Loosen the remaining hex nuts that secure the skid shoes.
3. Slide the shave plate out of the off-set slot at the bottom of the housing, and from between the skid shoes and side panels of the housing.
4. With the mounting holes toward the back, slide the new shave plate into position and secure with the fasteners removed previously.

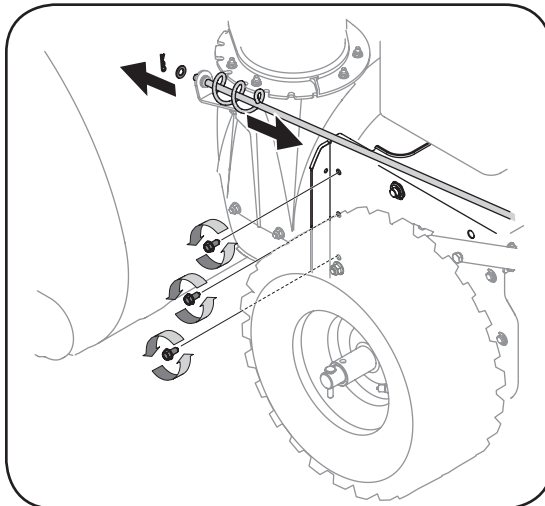

Figure 6-4

### Replacing Belts

1. Disconnect the chute crank assembly at the discharge chute end by removing the hairpin clip and the flat washer. Refer to Figure 6-4.
2. Remove the plastic belt cover, located near the engine, by removing the three self-tapping screws that secure it. See Figure 6-5.
3.
  - a. Loosen the bolt shown in Figure 6-6 securing the belt keeper bracket and remove the other bolt.
  - b. Push the belt keeper and bracket up off the engine pulley. See Figure 6-7.

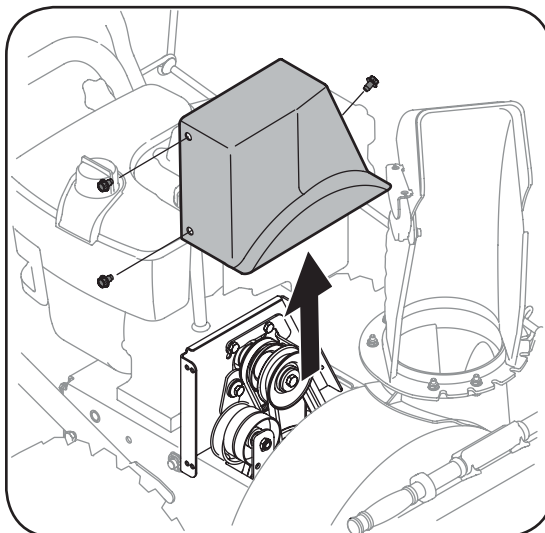

Figure 6-5

### Auger Belt

4. Remove the hairpin clip and flat washer from the ferrule in order to disconnect the auger idler rod from the brake bracket assembly. See Figure 6-8.
5. Unhook the spring found on the end of the auger cable from its respective actuator bracket. Refer to Figure 3-10 in the "Setting Up Your Snow Thrower" section.

6

## Maintaining Your Snow Thrower



Specifications are subject to change without notification or obligation. Images may not reflect your exact model and are for reference purposes only.

# 6

## Maintaining Your Snow Thrower



### WARNING

Always stop engine, disconnect spark plug, and ground against engine before performing any type of maintenance on your machine.

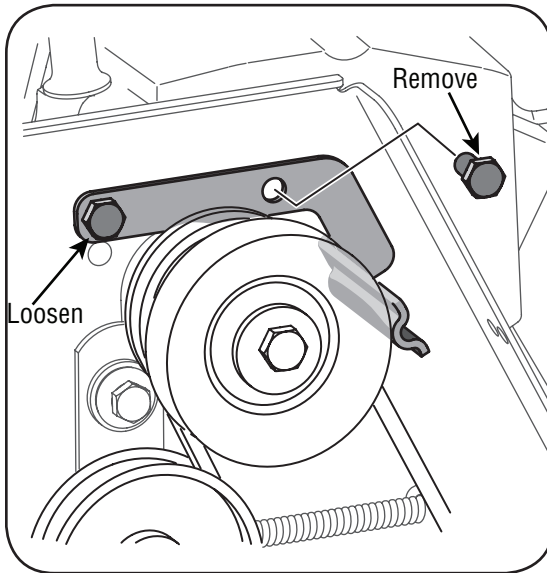

Figure 6-6

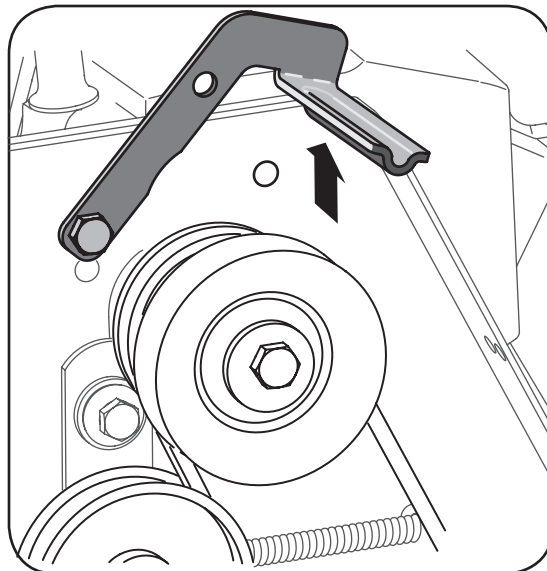

Figure 6-7

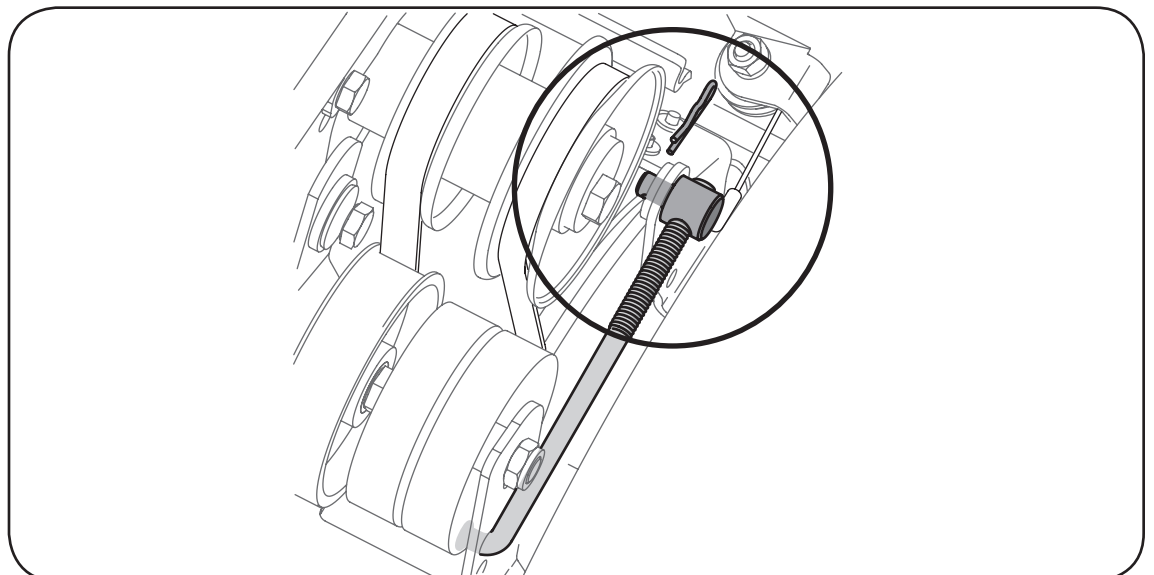

Figure 6-8

6. Slip the auger control belt (the front belt) off the engine pulley.
7. Pull the brake bracket assembly towards the cable guide roller and unhook the auger cable "Z" fitting. See Figure 6-9.
8. Remove the upper bolts which attach the auger housing assembly to the frame assembly using a 9/16" wrench. Refer to Figure 6-4 on previous page.
9. Place a block of wood underneath the auger housing as shown in Figure 6-10 and separate auger housing from the frame by tilting the housing forward and pulling up the handles.
10. a. Using a 1/2" wrench, remove the hex screw and cupped washer from the center of the pulley on the auger housing. See Figure 6-11.  
b. Lift the brake bracket assembly out of the pulley groove  
c. Remove the pulley. Be careful not to lose the key.
11. Remove and replace auger belt inside belt keepers.
12. Apply Loctite 262 to the threads of the hex screw used for mounting the auger pulley.
13. Reassemble pulley to auger housing with hex screw and cupped washer (cupped side toward the pulley). Torque hex screw 150-250 in. lbs.

**NOTE:** Make sure key is in place on shaft and brake puck is seated in the pulley groove.

If also replacing the drive belt, proceed to the "Drive Belt" instruction. If not, reassemble by performing the previous steps in the opposite order and manner of removal.

**Proper Adjustment:** With the auger clutch lever in the disengaged position, the top surface of the new belt should be even with the outside diameter of the pulley.

1. To adjust, disconnect ferrule from brake bracket assembly and thread ferrule in (towards idler) to increase tension on belt, and out to decrease tension.

**NOTE:** The brake puck must always be firmly seated in the pulley groove when auger control is disengaged.

### Drive Belt

1. Pull the idler pulley away from the backside of the drive belt to relieve the tension and slide the drive belt off the idler pulley (If necessary unhook the extension spring from the belt cover plate). See Figure 6-12.
2. Roll the drive belt off the lower drive pulley.
3. Remove the belt from the engine pulley.
4. Install the new belt on the pulleys in the reverse order and re-tension with the idler pulley.
5. Reassemble by performing the previous steps in the opposite order and manner of removal.

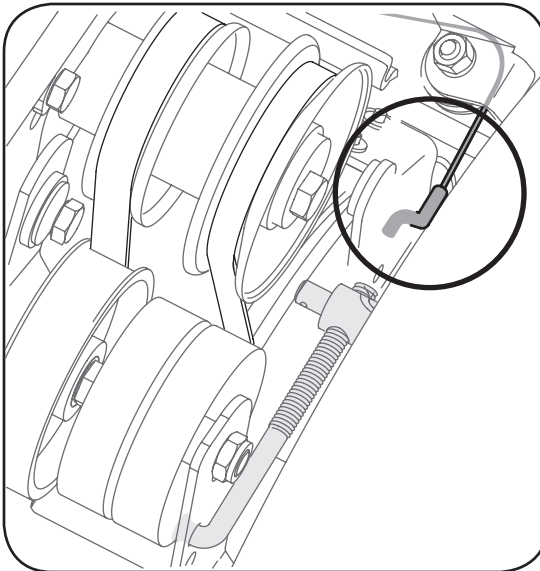

Figure 6-9

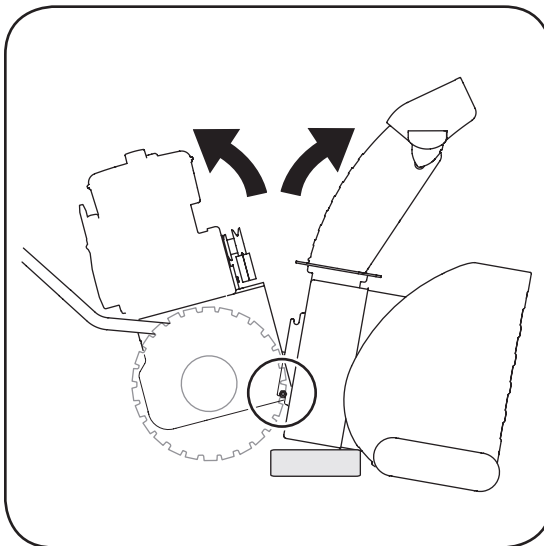

Figure 6-10

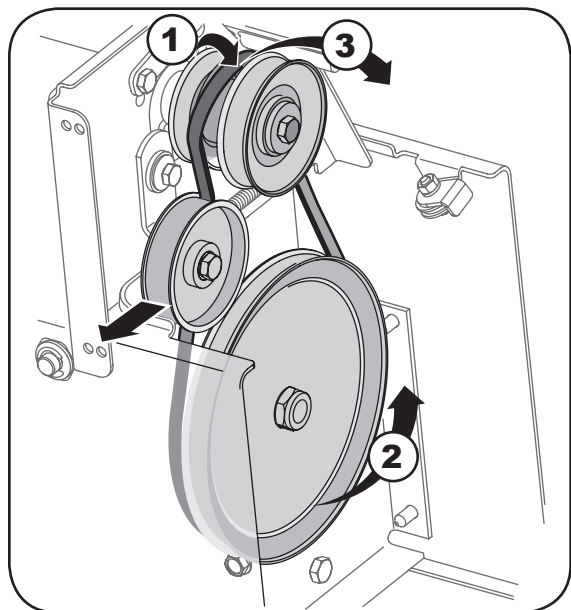

Figure 6-12

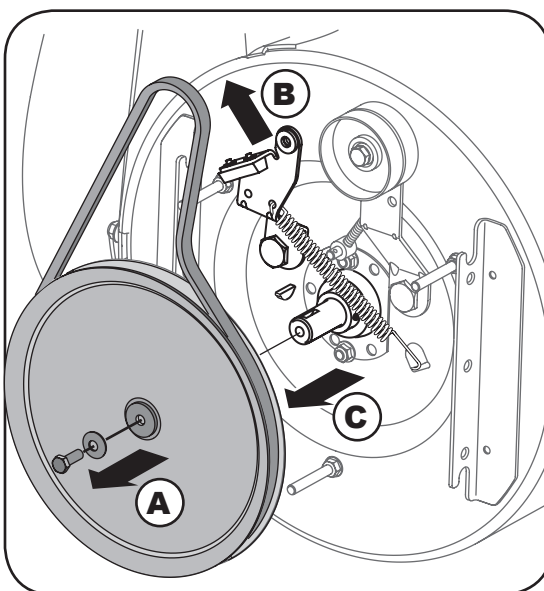

Figure 6-11

# 6

## Maintaining Your Snow Thrower



Specifications are subject to change without notification or obligation. Images may not reflect your exact model and are for reference purposes only.



# 6

## Maintaining Your Snow Thrower



### WARNING

Always stop engine, disconnect spark plug, and ground against engine before performing any type of maintenance on your machine.



Specifications are subject to change without notification or obligation. Images may not reflect your exact model and are for reference purposes only.

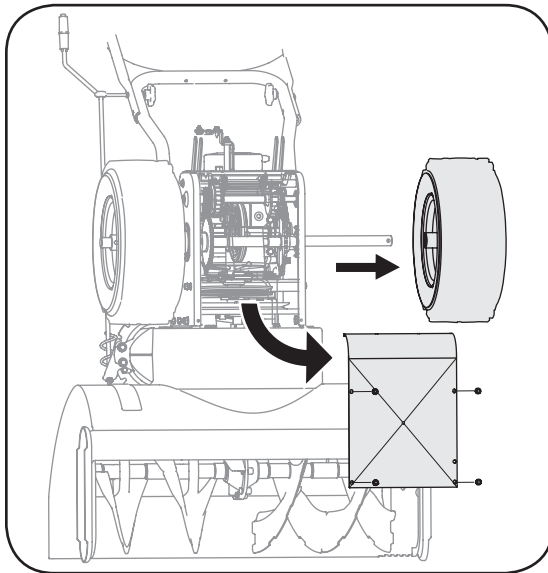

Figure 6-13

### Changing Friction Wheel

The rubber on the friction wheel is subject to wear and should be checked after the first 25 hours of operation, and periodically thereafter. Replace the friction wheel if any signs of wear or cracking are found.

- Drain the gasoline from the snow thrower, or place a piece of plastic under the gas cap.
- Tip the snow thrower up and forward, so that it rests on the housing.
- Remove screws from the frame cover underneath the snow thrower. See Figure 6-13.
- Remove the right wheel from the axle.
- Using a 3/4" wrench, hold the hex shaft and remove the hex screw and cupped washer and bearing from left side of the frame. Refer to Figure 6-14.
- Holding the friction wheel assembly, slide the hex shaft out of the right side of the unit. The spacer on the left side of the hex shaft will fall and the sprocket should remain hanging loose in the chain.
- Lift the friction wheel assembly out between the axle shaft and the drive shaft assemblies.
- Remove four screws securing the friction wheel to the hub assembly. See Figure 6-15. Discard old friction wheel.

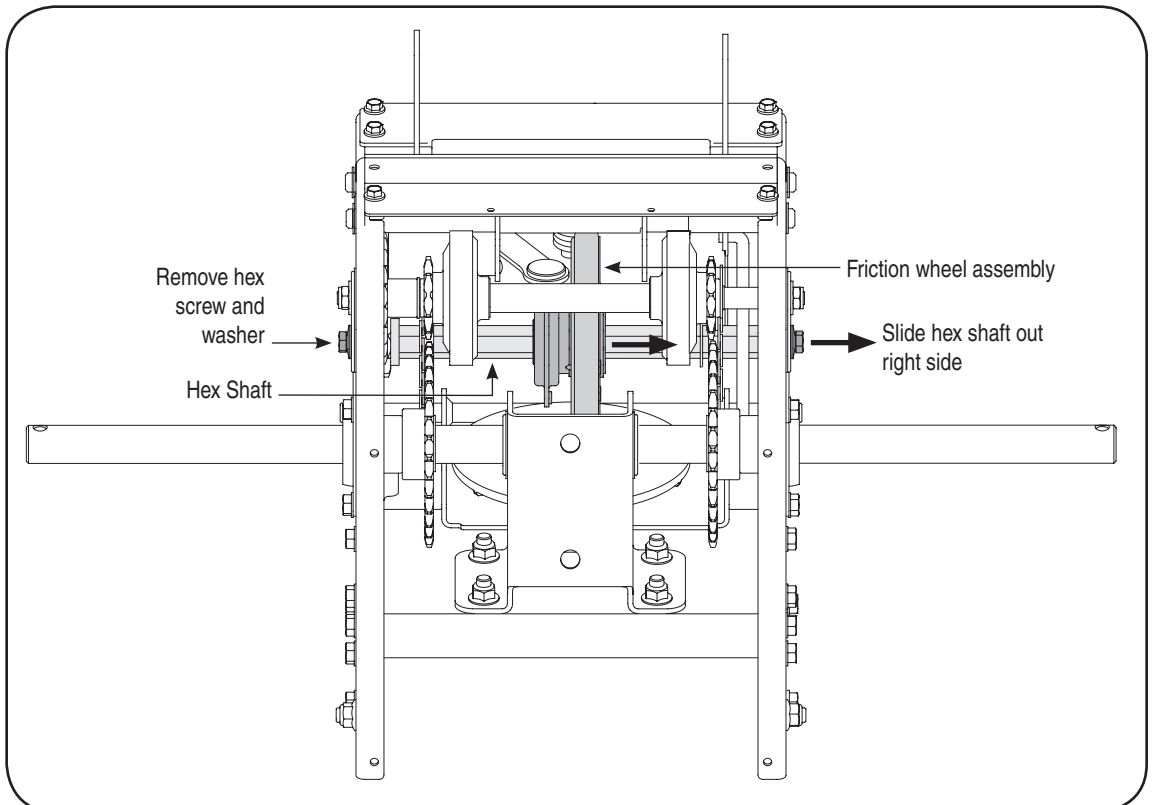

Figure 6-14

- Reassemble the new friction wheel to the hub assembly, tightening the four screws in rotation and with equal force. It is important to assemble the friction wheel symmetrically for proper functioning.
- Insert the pin from the shift arm assembly into the friction wheel assembly and hold assembly in position. Refer to Figure 6-16.
- Slide the hex shaft through the left side of the housing and through the friction wheel assembly.
- Insert the hex shaft through the sprocket and the spacer. Make certain that the chain engages both the large and the small sprocket.

**NOTE:** If the sprocket fell from the snow thrower while removing the hex shaft, place the sprocket on the hex shaft. Position the hex hub of the sprocket toward the friction wheel when sliding the sprocket on to the hex shaft.

- Secure with the cupped washer and hex bolt removed earlier.
- Secure the frame cover with self-tapping screws. Put the snow thrower down to its normal operating position.

**NOTE:** If you placed plastic film under the gas cap, be certain to remove it.

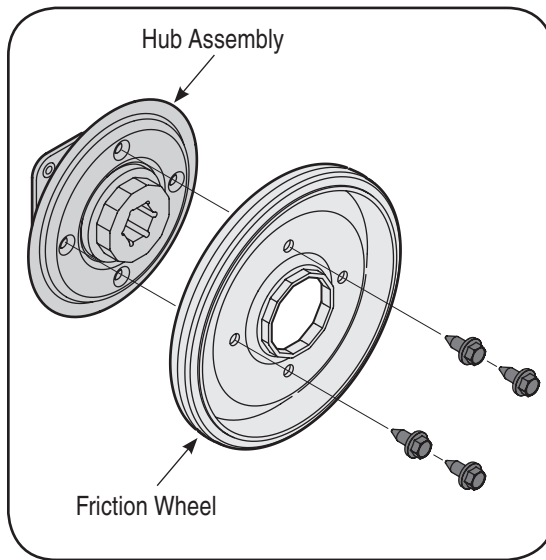

Figure 6-15

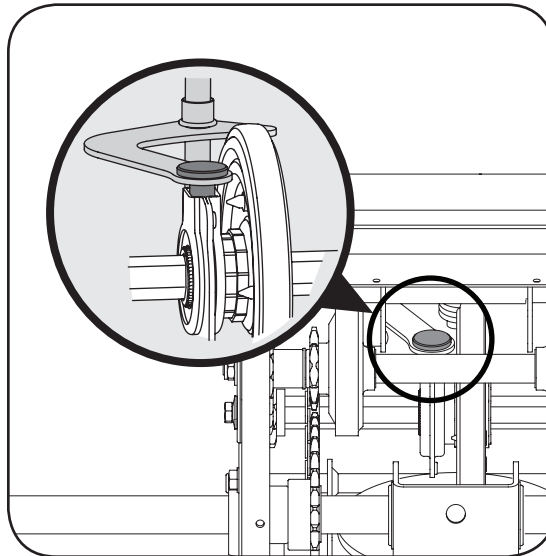

Figure 6-16

# 6

## Maintaining Your Snow Thrower



Specifications are subject to change without notification or obligation. Images may not reflect your exact model and are for reference purposes only.

# 7

## Off-Season Storage



### WARNING

Never store snow thrower with fuel in tank indoors or in poorly ventilated areas, where fuel fumes may reach an open flame, spark or pilot light as on a furnace, water heater, clothes dryer or gas appliance.

Fuel left in engine during warm weather deteriorates and will cause serious starting problems.

Never use engine or carburetor cleaning products in the fuel tank or permanent damage may occur.

If the snow thrower will not be used for 30 days or longer, or if it is the end of the snow season when the last possibility of snow is gone, the equipment needs to be stored properly. Follow storage instructions below to ensure top performance from the snow thrower for many more years.

## Preparing Engine

NOTE: Refer to the engine manual for more detailed information on preparing the snow thrower engine for storage.

### Short-Term Storage

It is important to prevent gum deposits from forming in essential fuel system parts of the engine such as the carburetor, fuel filter, fuel hose, or tank during short-term storage (15-30 days). To prevent this, treat the fuel system using a fuel stabilizer.

Fuel stabilizer (such as STA-BIL™ or ULTRA-FRESH™) is an acceptable alternative in minimizing the formation of fuel gum deposits during storage. Add stabilizer to gasoline in fuel tank or storage container. Always follow mix ratio found on stabilizer container. Run engine at least 10 minutes after adding stabilizer to allow it to reach the carburetor.



**WARNING:** Never store snow thrower with fuel in tank indoors or in poorly ventilated areas, where fuel fumes may reach an open flame, spark or pilot light as on a furnace, water heater, clothes dryer or gas appliance.



**CAUTION:** *Alcohol blended fuels (called gasohol or using ethanol or methanol) can attract moisture which leads to separation and formation of acids during storage. Acidic gas can damage the fuel system of an engine while in storage.*

### Long-Term Storage

To avoid engine problems, the fuel system should be emptied before storage for 30 days or longer.



**WARNING:** Fuel left in engine during warm weather deteriorates and will cause serious starting problems.

1. Run the engine until the fuel tank is empty and it stops due to lack of fuel. Do not attempt to pour fuel from the engine.



**WARNING:** Never use engine or carburetor cleaning products in the fuel tank or permanent damage may occur.

2. Remove the spark plug and pour one (1) ounce of engine oil through the spark plug hole into the cylinder. Cover spark plug hole with a rag and crank the engine several times to distribute the oil. Replace spark plug.

## Preparing Snow Thrower

- When storing the snow thrower in an unventilated or metal storage shed, care should be taken to rustproof the equipment. Using a light oil or silicone, coat the equipment, especially any chains, springs, bearings and cables.
- Remove all dirt from exterior of engine and equipment.
- Follow lubrication recommendations.
- Store equipment in a clean, dry area.

Problem	Cause	Remedy
Engine fails to start	<ol style="list-style-type: none"> <li>1. Choke not in ON position.</li> <li>2. Spark plug wire disconnected.</li> <li>3. Fuel tank empty or stale fuel.</li> <li>4. Engine not primed.</li> <li>5. Faulty spark plug.</li> <li>6. Blocked fuel line.</li> <li>7. Safety key not in ignition on engine.</li> </ol>	<ol style="list-style-type: none"> <li>1. Move choke to ON position.</li> <li>2. Connect wire to spark plug.</li> <li>3. Fill tank with clean, fresh gasoline.</li> <li>4. Prime engine as instructed in "Operating Your Snow Thrower".</li> <li>5. Clean, adjust gap, or replace.</li> <li>6. Clean fuel line.</li> <li>7. Insert key fully into the switch.</li> </ol>
Engine runs erratic	<ol style="list-style-type: none"> <li>1. Unit running on CHOKE.</li> <li>2. Blocked fuel line or stale fuel.</li> <li>3. Water or dirt in fuel system.</li> <li>4. Carburetor out of adjustment.</li> </ol>	<ol style="list-style-type: none"> <li>1. Move choke lever to OFF position.</li> <li>2. Clean fuel line; fill tank with clean, fresh gasoline.</li> <li>3. Drain fuel tank. Refill with fresh fuel.</li> <li>4. Contact an authorized Service Center.</li> </ol>
Engine overheats	<ol style="list-style-type: none"> <li>1. Carburetor not adjusted properly.</li> </ol>	<ol style="list-style-type: none"> <li>1. Contact Service Center.</li> </ol>
Excessive Vibration	<ol style="list-style-type: none"> <li>1. Loose parts or damaged auger.</li> </ol>	<ol style="list-style-type: none"> <li>1. Stop engine immediately and disconnect spark plug wire. Tighten all bolts and nuts. If vibration continues, have unit serviced by an authorized Service Center.</li> </ol>
Loss of power	<ol style="list-style-type: none"> <li>1. Spark plug wire loose.</li> <li>2. Gas cap vent hole plugged.</li> <li>3. Exhaust port plugged.</li> </ol>	<ol style="list-style-type: none"> <li>1. Connect and tighten spark plug wire.</li> <li>2. Remove ice and snow from gas cap. Be certain vent hole is clear.</li> <li>3. Contact Service Center.</li> </ol>
Unit fails to propel itself	<ol style="list-style-type: none"> <li>1. Drive control cable in need of adjustment.</li> <li>2. Drive belt loose or damaged.</li> </ol>	<ol style="list-style-type: none"> <li>1. Adjust drive control cable. Refer to "Making Adjustments".</li> <li>2. Replace drive belt.</li> </ol>
Unit fails to discharge snow	<ol style="list-style-type: none"> <li>1. Chute assembly clogged.</li> <li>2. Foreign object lodged in auger.</li> <li>3. Auger control cable in need of adjustment.</li> <li>4. Auger belt loose or damaged.</li> <li>5. Shear pin(s) sheared.</li> </ol>	<ol style="list-style-type: none"> <li>1. Stop engine immediately and disconnect spark plug wire. Clean chute assembly and inside of auger housing with clean-out tool or a stick.</li> <li>2. Stop engine immediately and disconnect spark plug wire. Remove object from auger with clean-out tool or a stick.</li> <li>3. Refer to Auger Control Test.</li> <li>4. Refer to Maintenance section.</li> <li>5. Replace with new shear pin(s).</li> </ol>

# 8

## Troubleshooting



**This section addresses minor service issues. For further details, contact an authorized service center.**

Storm 13045

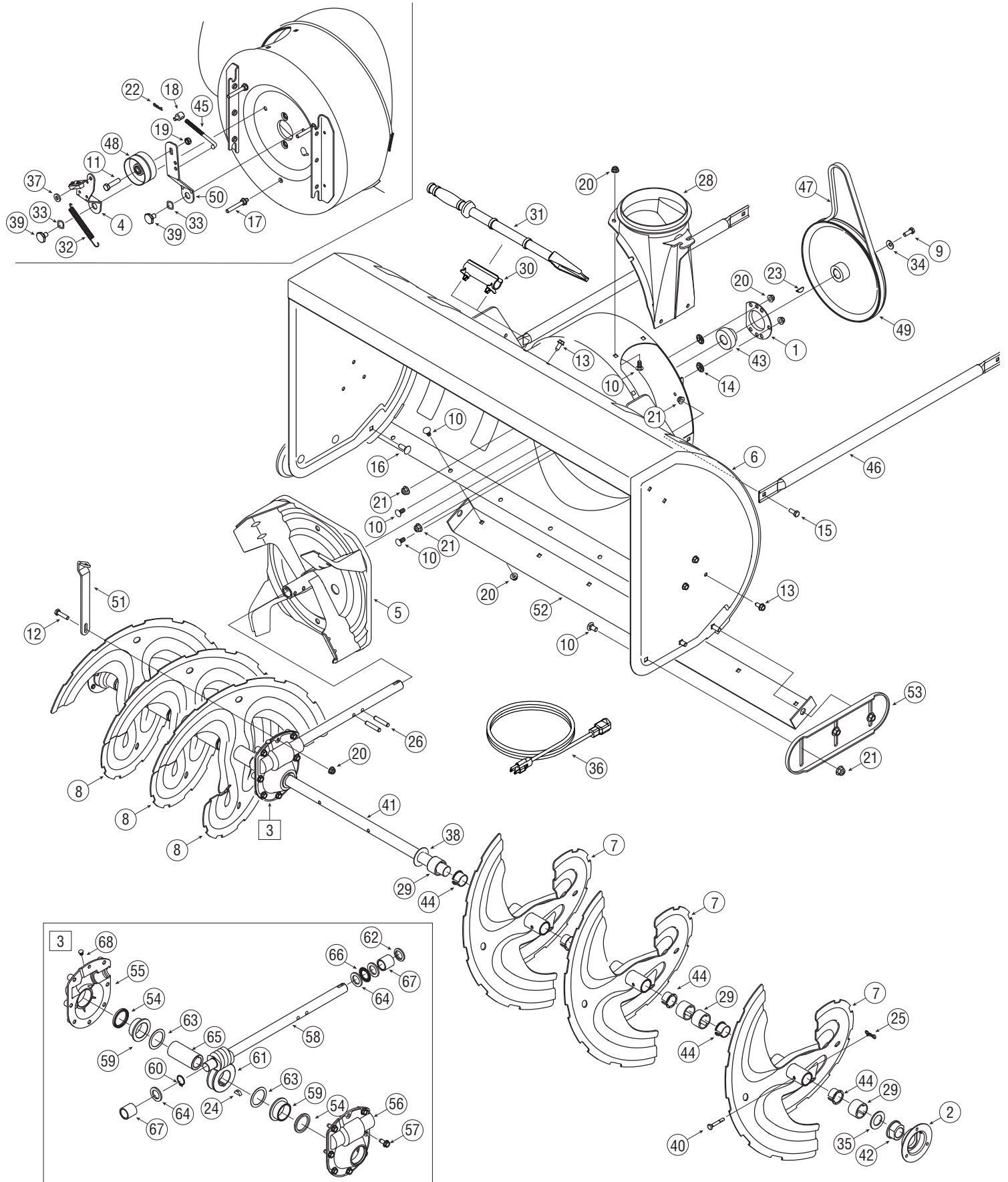



# 9

## Parts List

To order replacement parts, call  
1-800-648-6776  
or visit  
[www.troybilt.com](http://www.troybilt.com)

Ref. No.	Part No.	Description
1	05244B	Housing, Bearing
2	05845C	Housing, Double D Bearing
3	618-0257	Gear Box Assembly, Auger
4	618-0281A	Bracket Assy, Auger Brake
5	684-0090B	Impeller, 16"
6	684-04223	Housing, Auger - 45"
7	684-04151	Spiral Assy, LH
8	684-04152	Spiral Assy, RH
9	710-0371	Screw, Hex Cap Lock
10	710-0451	Screw, Carriage, 5/16-18 x .75
11	710-0459A	Screw, Hex Cap, 3/8-24 x 1.5
12	710-0528	Screw, Hex Cap, 5/16-18 x 1.25
13	710-04484	Screw, 5/16-18 x .750
14	726-04012	Nut, Push
15	710-3008	Screw, 5/16-18 x .75 GR5
16	710-3168	Screw, Carriage, 3/8-16 x 1.0
17	710-04606	Screw, 5/16-18 x .4300
18	711-0677	Ferrule
19	712-0116	Nut, Hex Lock, 3/8-24
20	712-04063	Nut, Flange Lock, 5/16-18
21	712-04065	Nut, Flange Lock, 3/8-16
22	714-0104	Pin, Internal Cotter
23	714-0126	Key, Hi Pro, 3/16 x 3/4
24	714-0135	Key, Woodruff, 1/4 x 3/4
25	714-04040	Pin, Bowtie Cotter
26	715-0118	Pin, Spirol, 5/16 x 1.75
27	725-0157†	Tie, Cable
28	731-1696A	Adapter, Chute, 6"
29	731-05163	Spacer, 1.0 x 1.5 x 1.0
30	731-2635	Clip, Mounting
31	731-2643	Tool, Cleanout
32	732-0858	Spring, Extension
33	736-0174	Washer, .625 x .885 x .015
34	736-0242	Washer, .34 x .872 x .06

Ref. No.	Part No.	Description
35	750-04020	Spacer, 1.004 x 1.375 x .25
36	629-0071	Extension Cord, 110V
37	736-3008	Washer, .344 x .75 x .12
38	736-3046A	Washer, 1.01 x 1.86 x .06
39	738-0281	Screw, Shoulder, .625 x .17
40	738-04155	Pin, Shear, .25 x 1.75
41	738-04159	Shaft, Spiral 45"
42	741-0192	Bearing, Flange w/Flats
43	741-04024	Bearing, Self Aligning
44	741-0494	Bushing, Flange, 1.05 x 1.16
45	747-0980A	Rod, Auger Idler
46	749-1117	Tube, Support
47	754-0222A	Belt, V, 1/2 x 44
48	756-0178	Pulley, Flat Idler, 2.75 OD
49	756-0243	Pulley, Auger Drive, 10.0
50	784-0385B	Bracket, Auger Idler
51	790-00264	Bracket, Gear Box Support
52	790-00280	Plate, Shave 45"
53	784-5697	Shoe, Skid
54	721-0146	Oil Seal
55	618-0246	Hsg Assy Auger, RH (Inc. 54 & 59)
56	618-0247	Hsg Assy Auger, LH (Inc. 54 & 59)
57	710-1260A	Screw LD, 5/16-18 x .750
58	711-1133	Shaft, Drive, Auger
59	741-0670	Flange Bearing
60	716-0111	Ext, Ret, Ring
61	717-1425	Gear, Worm, LH
62	721-0145	Seal, Oil
63	736-0266	Washer, Flat, 1.52 ID x 2.0 OD
64	736-0291	Washer, Flat, .88 ID x .38 OD
65	738-0275	Shaft, Gear, Worm
66	741-0184	Brg, Thrust
67	741-0217	Sleeve
68	721-0325	Plug

† Not Shown

Storm 13045

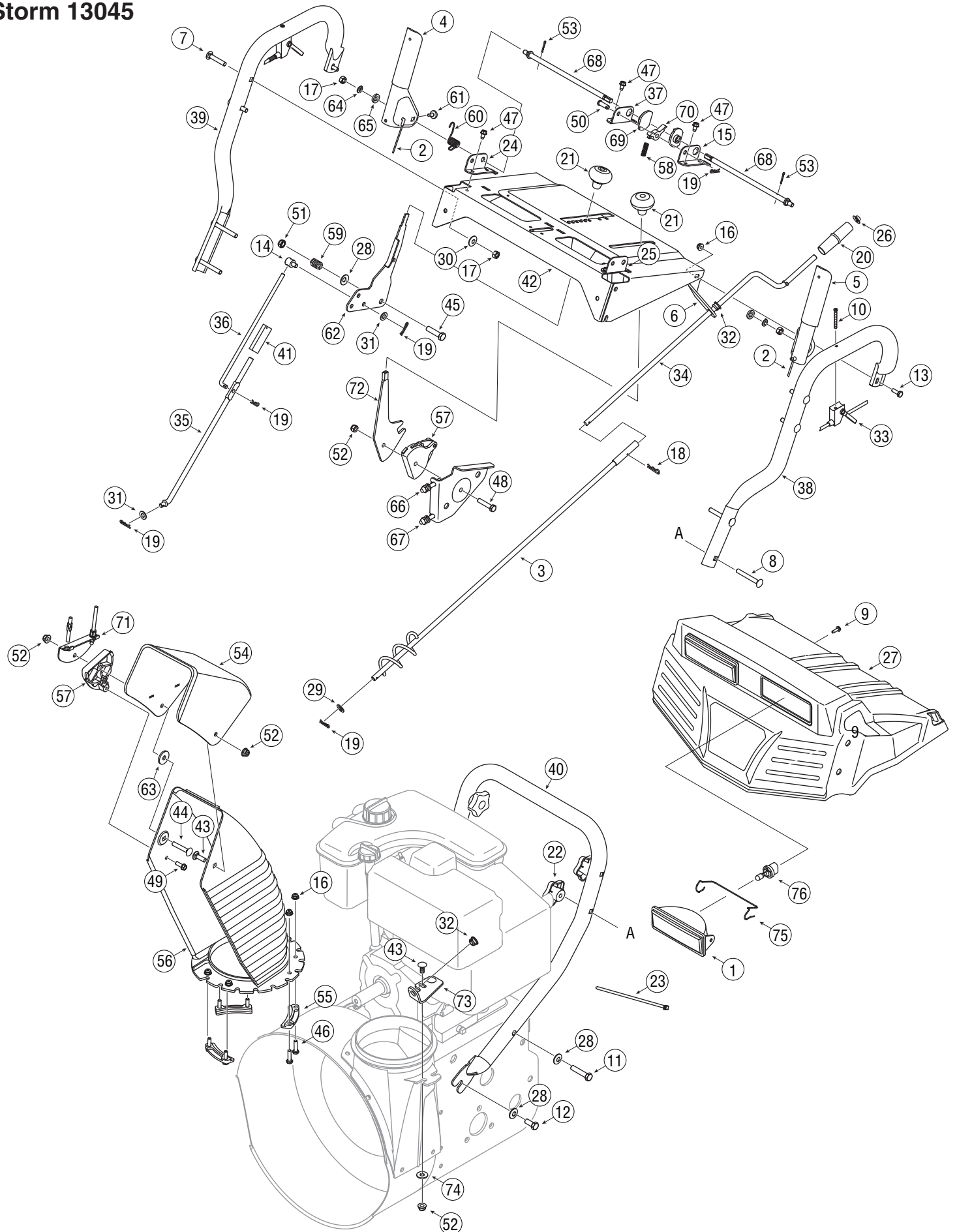

# 9

## Parts List

To order replacement parts, call  
1-800-648-6776  
or visit  
[www.troybilt.com](http://www.troybilt.com)

Ref. No.	Part No.	Description
1	725-1672	Light Housing
2	646-0012	Cable Assembly, Auger/Drive
3	684-0053B	Crank, Chute, 26.0
4	705-5218	Handle, Engage, RH
5	705-5219	Handle, Engage, LH
6	705-5266	Bracket, Chute Crank
7	710-0458	Screw, Carr., 5/16-18 x 1.75
8	710-0572	Screw, Carr., 5/16-18 x 2.5
9	710-1003	Screw, #10-16 x .625
10	710-1625	Screw, #10-24 x 1.75
11	710-1878	Screw, Hex, 3/8-16 x 1.75
12	710-1879	Screw, Hex, 3/8-16 x .88
13	710-3015	Screw, Hex, 1/4-20 x .75
14	711-0677	Ferrule, 5/16-18 x .312 Dia
15	784-5679	Bracket, Handle Support - LH
16	712-04064	Nut, Hex Flange, 1/4-20
17	712-3010	Nut, Hex, 5/16-18 GR5
18	714-0101	Pin, Internal Cotter
19	714-0104	Pin, Internal Cotter
20	720-0201A	Knob, Crank
21	720-04039	Knob, Shift
22	720-04072	Knob, Star, 5/16-18
23	725-0157	Tie, Cable
24	784-5682	Bracket, Handle Support - RH
25	784-5681	Bracket, Handle Support - LH
26	726-0100	Cap, Push, 3/8
27	731-04069	Panel, Handle, Style 9
	777I22553	Graphic, Auger/Chute
	777I22554	Graphic, Chute Tilt
	777I22556	Graphic, Starting Instructions
28	736-0105	Washer, Bell, .375 x .87 x .063
29	736-0185	Washer, Flat, .375 x .738 x .063
30	736-0242	Washer, Bell, .34 x .872 x .06
31	736-0275	Washer, Flat, .344 x .688 x .065
32	741-0475	Bushing, Plastic, .38 ID
33	746-0950A	Cable Assembly, Trigger
34	747-0624	Rod, Chute Crank
35	747-0983A	Rod, Lower Shift
36	747-0997	Rod, Upper Shift
37	784-5680	Bracket, Handle Support - RH

Ref. No.	Part No.	Description
38	749-0989A	Handle, Upper LH
39	749-0990A	Handle, Upper RH
40	749-0991	Handle, Lower
41	750-0963	Connector, Shift Rod
42	684-0102A	Panel, Handle
43	710-0276	Screw, Carriage, 5/16-18 x 1.0
44	710-0458	Screw, Carriage, 5/16-18 x 1.75
45	710-0459A	Screw, Hex, 3/8-24 x 1.5
46	710-0597	Screw, Hex, 1/4-20 x 1.0
47	710-0599	Screw, Hx, 1/4-20 x .5
48	710-0805	Screw, Hex, 5/16-18 x 1.5
49	710-0895	Screw, Hx, 1/4-15 x .75
50	711-0653	Pin, Clevis, .312 x 1.0
51	712-0116	Nut, Insert, 3/8-24
52	712-04063	Nut, Flange Lock, 5/16-18
53	714-0507	Pin, Cotter, 3/32 x .75
54	731-0846C	Chute, Upper, 6.0
	777S32280	Graphic, Danger
55	731-0851A	Flange Keeper, Chute
56	731-0903D	Chute, Lower
57	731-1313C	Cable Guide, Chute Tilt
58	732-0145	Spring, Compression
59	732-0193	Spring, Compression
60	732-0746	Spring, Torsion
61	735-0199A	Bumper, Rubber
62	784-5619B	Handle, Shift
63	736-0231	Washer, Flat, .344 x 1.125 x .12
64	736-0119	Washer, Lock, 5/16
65	736-0509	Washer, Flat, .35 x .72 x .134
66	746-0902	Cable, Chute Control, 66"
67	746-0903	Cable, Chute Control w/Clip
68	747-0877	Rod, Cam
69	748-0362	Cam, Handle Lock
70	748-0363	Pawl, Handle Lock
71	784-5594	Bracket, Cable
72	784-5604A	Handle, Chute Tilt
73	784-5123	Bracket, Chute Crank
74	736-0159	Washer, Flat, .349 x .879 x .063
75	747-1136	Headlight Retainer
76	725-1658	Halogen Lamp
77†	629-04010A	Light Harness

† Not Shown

Storm 13045

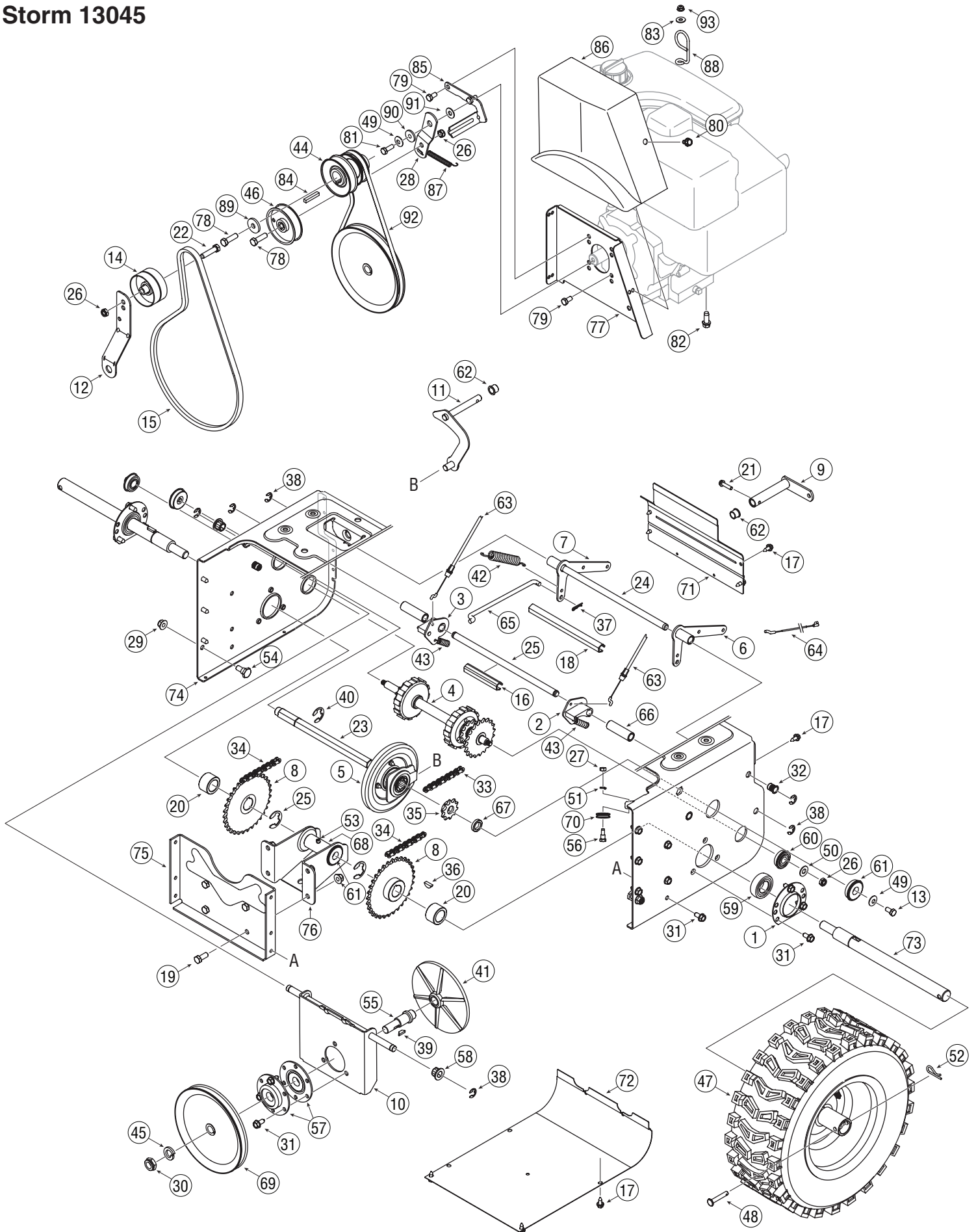

# 9

## Parts List

To order replacement parts, call  
**1-800-648-6776**  
 or visit  
**www.troybilt.com**

Ref. No.	Part No.	Description
1	05244B	Housing, Bearing
2	618-0279	Dogg, Steering Drive, LH
3	618-0280	Dogg, Steering Drive, RH
4	618-0282E	Shaft Assembly, Steering
5	618-04178	Assembly, Friction Wheel
	718-04034	Wheel, Friction, Bonded
	710-0896	Screw, Hex Wash
6	684-0118A	Bracket, Auger Actuator
7	684-0119A	Bracket, Drive Actuator
8	684-04235	Sprocket, 32T
9	684-0161	Arm, Shift
10	684-04212	Brkt, Friction Drive Suprt.
11	684-04103	Rod Assembly, Shift
12	784-0385B	Brkt., Idler, Auger
13	710-0538	Screw, Hex Cap Lock,
14	756-0178	Idler, Flat, 2.75 OD
15	754-0222A	V-Belt, 1/2 x 44.0
16	750-04718	Spchr., .51 ID x 3.66 Lg.
17	710-1652	Screw, Hex Wash.
18	750-04717	Spchr., .51 ID x 7.895 Lg.
19	710-3001	Screw, Hex Cap, 3/8-16
20	750-04703	Spchr., 1.0 ID x 1.50 OD
21	710-0788	Screw, Hex, 1/4-20 x 1.00
22	710-0459A	Screw, 3/8-24 x 1.50
23	711-04279	Shaft, Hex Drive
24	711-04605	Shaft, Actuator
25	716-04048	Ring, Retainer
26	712-0116	Nut, Hex Insert Jam Lock
27	712-0138	Nut, Hex, 1/4-28 GR5
28	784-5726	Bracket, Idler, Drive
29	712-04065	Nut, Hx Flnge Insert Lk
30	712-0413	Nut, Hx Insert Jam Lk
31	710-04484	TT Screw, 5/16-18 x .750
32	712-0717	Nut, Insert 3/8-16
33	713-0284	Chain, Endless, #41 x 36L
34	713-0286	Chain, #420 x 40L
35	713-04015	Sprocket, #41 x 10T
36	714-0135	Key, Woodruff
37	714-0104	Pin, Internal Cotter
38	716-0104	E-Ring
39	714-0388	Key, Hi-Pro, 3/16 x 5/8
40	716-0136	Ring, Retaining

Ref. No.	Part No.	Description
41	717-0302	Plate, Drive
42	732-0121	Spring, Extension
43	732-0209	Spring, Extension
44	756-0241B	Pulley, Dbl, 3.25 OD
45	736-0158	Washer, Lock, 5/8
46	756-0240	Pulley, Flat Idler, 3.0 OD
47	634-0225	Wheel Assembly - LH
	634-0226	Wheel Assembly - RH
	734-2031	Tire
	734-0255	Valve
	741-0246A	Bearing
48	711-04615	Pin, Clevis
49	736-0242	Wsh, Bell., .34 x .872 x .06
50	736-0300	Wash, .406 x .875 x .059
51	736-0329	Washer, Lock, 1/4
52	714-0149B	Pin, Internal Cotter
53	737-3000	Fitting, Lube, 3/16 Drive
54	738-0143	Screw, Shldr., .498 x .34
55	738-0279	Spindle, Drive Plate
56	738-0924A	Screw, Hex Shldr., 1/4-28
57	741-0163A	Ass'y, Bearing/Housing
58	741-04108	Bearing, Hex Flange
59	741-04025	Bearing, Self Aligning
60	741-04076	Bearing, Ball
61	741-0563	Bearing, Ball
62	741-0748	Bush, Flg., .5 ID x .627 OD
63	746-0949A	Cable, Steering
64	746-0951	Cable, Auger Idler
65	747-0973	Rod, Drive Clutch
66	750-0903B	Spchr., .514 x .632 x 2.44
67	750-0997	Spacer, .675 x 1.0 x .23
68	750-1302B	Spchr, .6725 x 1.125 x 2.48
69	756-0344	Pulley, Drive
70	756-0625	Roller, Cable
71	790-00257	Cover, Upper Frame
72	790-00259	Cover, Lower Frame
73	711-04606	Axle, Wheel
74	790-00255	Frame, Transmission
75	784-0406A	Bracket, Frame Support
76	784-0407	Bracket, Axle Support
77	790-00254	Bracket, Belt Cover
78	710-0191	Screw, 3/8-14 x 1.25 GR8

Continued on following page



# 9

## Parts List

To order replacement parts, call  
1-800-648-6776  
or visit  
[www.troybilt.com](http://www.troybilt.com)

Continued from previous page

Ref. No.	Part No.	Description
79	710-0237	Screw, 5/16-24 x .625
80	710-0607	Screw, Hx Wash Hd Tapp
81	710-1245B	Screw, Hx Cap 5/16-24
82	710-0654A	Screw, 3/8-16 x 1.00
83	736-0173	Wsh, Flat, .28 x .74 x .063
84	714-0118	Key, Square, 1/4 x 1.5
85	790-00167A	Brkt., Belt, Keeper
86	731-2531	Cover, Belt
87	732-0303	Spring, Extension
88	732-0705	Guide, Chute Cable
89	736-0247	Washer, Flat, .406 x 1.25
90	748-0234	Spacer, Shoulder
91	736-0159	Washer, Flat, .349 x .879
92	754-0131	V-Belt, 3/8 x 35.5
93	712-04064	Nut, Flg Lk, 1/4-20

## NOTES

## MANUFACTURER'S LIMITED WARRANTY FOR



The limited warranty set forth below is given by Troy-Bilt LLC with respect to new merchandise purchased and used in the United States and/or its territories and possessions, and by MTD Products Limited with respect to new merchandise purchased and used in Canada and/or its territories and possessions (either entity respectively, "Troy-Bilt").

"Troy-Bilt" warrants this product (excluding its normal wear parts as described below) against defects in material and workmanship for a period of two (2) years commencing on the date of original purchase and will, at its option, repair or replace, free of charge, any part found to be defective in materials or workmanship. This limited warranty shall only apply if this product has been operated and maintained in accordance with the Operator's Manual furnished with the product, and has not been subject to misuse, abuse, commercial use, neglect, accident, improper maintenance, alteration, vandalism, theft, fire, water, or damage because of other peril or natural disaster. Damage resulting from the installation or use of any part, accessory or attachment not approved by Troy-Bilt for use with the product(s) covered by this manual will void your warranty as to any resulting damage.

Normal wear parts are warranted to be free from defects in material and workmanship for a period of thirty (30) days from the date of purchase. Normal wear parts include, but are not limited to items such as: batteries, belts, blades, blade adapters, grass bags, rider deck wheels, seats, snow thrower skid shoes, friction wheels, shave plates, auger spiral rubber and tires.

**HOW TO OBTAIN SERVICE:** Warranty service is available, WITH PROOF OF PURCHASE, through your local authorized service dealer. To locate the dealer in your area:

### In the U.S.A.

Check your Yellow Pages, or contact Troy-Bilt LLC at P.O. Box 361131, Cleveland, Ohio 44136-0019, or call 1-866-840-6483 or 1-330-558-7220, or log on to our Web site at [www.troybilt.com](http://www.troybilt.com).

### In Canada

Contact MTD Products Limited, Kitchener, ON N2G 4J1, or call 1-800-668-1238 or log on to our Web site at [www.mtdcanada.com](http://www.mtdcanada.com).

This limited warranty does **not** provide coverage in the following cases:

- a. The engine or component parts thereof. These items may carry a separate manufacturer's warranty. Refer to applicable manufacturer's warranty for terms and conditions.
- b. Log splitter pumps, valves, and cylinders have a separate one-year warranty.
- c. Routine maintenance items such as lubricants, filters, blade sharpening, tune-ups, brake adjustments, clutch adjustments,

deck adjustments, and normal deterioration of the exterior finish due to use or exposure.

- d. Service completed by someone other than an authorized service dealer.
- e. Troy-Bilt does not extend any warranty for products sold or exported outside of the United States and/or Canada, and their respective possessions and territories, except those sold through Troy-Bilt's authorized channels of export distribution.
- f. Replacement parts that are not genuine Troy-Bilt parts.
- g. Transportation charges and service calls.
- h. If Products are used commercially. (Troy-Bilt may separately offer Limited Commercial Warranties on certain select products. Ask your dealer or retailer for details or contact Troy-Bilt Service for more information).

**No implied warranty, including any implied warranty of merchantability of fitness for a particular purpose, applies after the applicable period of express written warranty above as to the parts as identified. No other express warranty, whether written or oral, except as mentioned above, given by any person or entity, including a dealer or retailer, with respect to any product, shall bind Troy-Bilt. During the period of the warranty, the exclusive remedy is repair or replacement of the product as set forth above.**

**The provisions as set forth in this warranty provide the sole and exclusive remedy arising from the sale. Troy-Bilt shall not be liable for incidental or consequential loss or damage including, without limitation, expenses incurred for substitute or replacement lawn care services or for rental expenses to temporarily replace a warranted product.**

Some states do not allow the exclusion or limitation of incidental or consequential damages, or limitations on how long an implied warranty lasts, so the above exclusions or limitations may not apply to you.

In no event shall recovery of any kind be greater than the amount of the purchase price of the product sold. **Alteration of safety features of the product shall void this warranty.** You assume the risk and liability for loss, damage, or injury to you and your property and/or to others and their property arising out of the misuse or inability to use the product.

This limited warranty shall not extend to anyone other than the original purchaser or to the person for whom it was purchased as a gift.

**HOW STATE LAW RELATES TO THIS WARRANTY:** This limited warranty gives you specific legal rights, and you may also have other rights which vary from state to state.

**IMPORTANT:** Owner must present Original Proof of Purchase to obtain warranty coverage.

**Troy-Bilt LLC, P.O. BOX 361131 CLEVELAND, OHIO 44136-0019; Phone: 1-866-840-6483, 1-330-558-7220  
MTD Canada Limited - KITCHENER, ON N2G 4J1; Phone 1-800-668-1238**