

For Parts Call 606-678-9623 or 606-561-4983

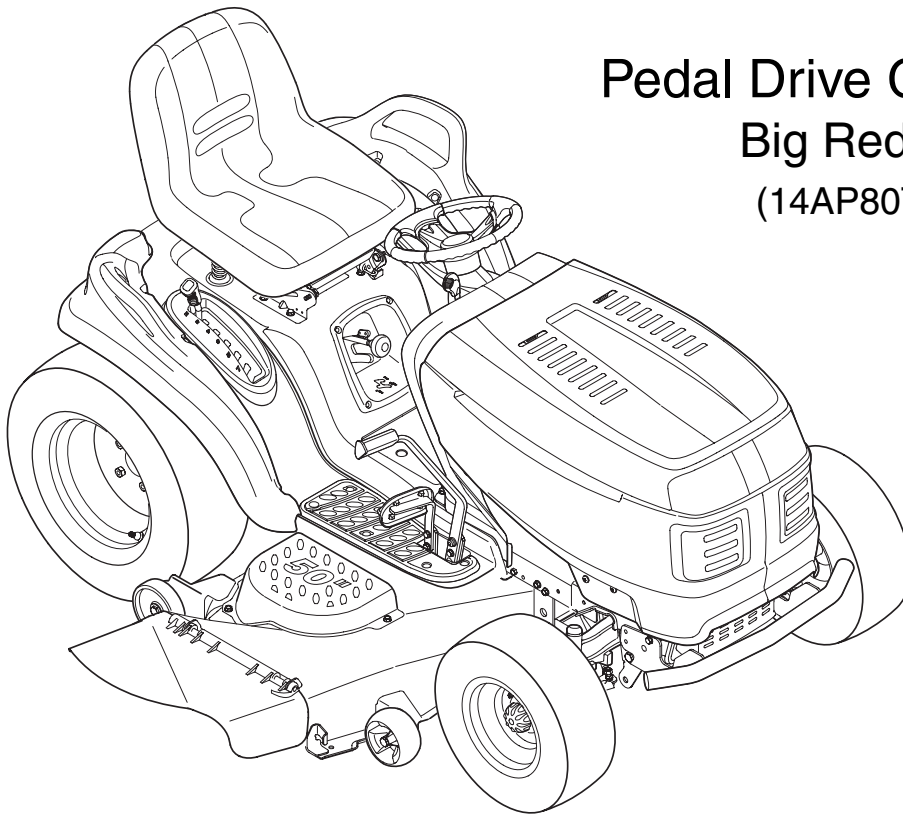

Operator's Manual



Pedal Drive Garden Tractor
Big Red GT50
(14AP80TP766)

IMPORTANT: Read safety rules and instructions carefully before operating equipment.

Warning: This unit is equipped with an internal combustion engine and should not be used on or near any unimproved forest-covered, brush-covered or grass-covered land unless the engine's exhaust system is equipped with a spark arrester meeting applicable local or state laws (if any). If a spark arrester is used, it should be maintained in effective working order by the operator. In the State of California the above is required by law (Section 4442 of the California Public Resources Code). Other states may have similar laws. Federal laws apply on federal lands. A spark arrester for the muffler is available through your nearest engine authorized service dealer or contact the service department, P.O. Box 361131 Cleveland, Ohio 44136-0019.

MTD LLC, P.O. BOX 361131 CLEVELAND, OHIO 44136-0019

PRINTED IN U.S.A.

FORM NO. 769-02401
(3/16/2006)

www.mymowerparts.com

TABLE OF CONTENTS

Content	Page	Content	Page
Important Safe Operation Practices	3	Maintaining Your Garden Tractor	18
Slope Gauge	7	Service	19
Tractor Set-up	8	Off-season Storage	22
Know Your Garden Tractor	10	Troubleshooting	24
Operating Your Garden Tractor	13	Illustrated Parts	25
Making Adjustments	16	Warranty	Back Page

FINDING MODEL NUMBER

This Operator's Manual is an important part of your new garden tractor. It will help you assemble, prepare and maintain the unit for best performance. Please read and understand what it says.



Before you start assembling your new equipment, please locate the model plate on the equipment and copy the information from it in the space provided below. A sample model plate is also illustrated below. You can locate the model plate by looking at the underside of the tractor's seat. This information will be necessary to use the manufacturer's web site and/or help from a Troy-Bilt Service Dealer.

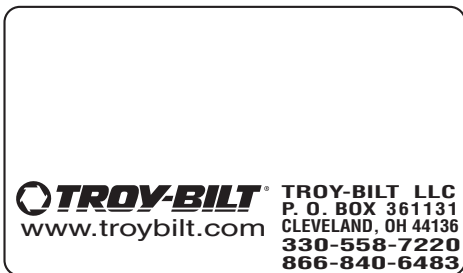

Copy the model number here: _____

Copy the serial number here: _____

CUSTOMER SUPPORT

Please do NOT return the unit to the retailer without first contacting Customer Support.

If you have difficulty assembling this product or have any questions regarding the controls, operation or maintenance of this unit, you can seek help from the experts. Choose from the options below:

	<p>Visit www.troybilt.com for many useful suggestions. Click on Customer Support button and you will get the options reproduced in the screen shot below. Click on the appropriate button and help is immediately available.</p>
	<p>To reach the Customer Support Line, please call 1-866-840-6483 or 1-330-558-7220.</p>
	<p>The engine manufacturer is responsible for all engine-related issues with regard to performance, power-rating, specifications, warranty and service. Please refer to the engine manufacturer's Owner's/ Operator's Manual packed separately with your unit for more information.</p>

SECTION 1: IMPORTANT SAFE OPERATION PRACTICES



WARNING: This symbol points out important safety instructions which, if not followed, could endanger the personal safety and/or property of yourself and others. Read and follow all instructions in this manual before attempting to operate this machine. Failure to comply with these instructions may result in personal injury. When you see this symbol—heed its warning.



DANGER: This machine was built to be operated according to the rules for safe operation in this manual. As with any type of power equipment, carelessness or error on the part of the operator can result in serious injury. This machine is capable of amputating hands and feet and throwing objects. Failure to observe the following safety instructions could result in serious injury or death.



This unit is equipped with an internal combustion engine and should not be used on or near any unimproved forest-covered, brush-covered or grass-covered land unless the engine's exhaust system is equipped with a spark arrester meeting applicable local or state laws (if any). If a spark arrester is used, it should be maintained in effective working order by the operator. In the State of California the above is required by law (Section 4442 of the California Public Resources Code). Other states may have similar laws. Federal laws apply on federal lands. A spark arrester for the muffler is available through your *Troy-Bilt* service dealer or contact Troy-Bilt at P.O. Box 361131 Cleveland, Ohio 44136-0019.

California Proposition 65 Warning:



WARNING: Engine exhaust, some of its constituents, and certain vehicle components contain or emit chemicals known to the State of California to cause cancer and birth defects or other reproductive harm.

GENERAL OPERATION

1. Read, understand, and follow all instructions on the machine and in the manual(s) before attempting to assemble and operate. Keep this manual in a safe place for future and regular reference and for ordering replacement parts.
2. Be familiar with all controls and their proper operation. Know how to stop the machine and disengage PTO/blades quickly.
3. Never allow children under 14 years old to operate this machine. Children 14 years old and over should read and understand the operation instructions and safety rules in this manual and should be trained and supervised by a parent or responsible adult.
4. Never allow adults to operate this machine without proper instruction.
5. To help avoid blade contact or a thrown object injury, keep bystanders, helpers, children and pets at least 75 feet from the machine while it is in operation. Stop machine if anyone enters the area.
6. Thoroughly inspect the area where the equipment is to be used. Remove all stones, sticks, wire, bones, toys, and other foreign objects which could be picked up and thrown by the blade(s). Thrown objects can cause serious personal injury.
7. Plan your mowing pattern to avoid discharge of material toward roads, sidewalks, bystanders and the like. Also, avoid discharging material against a wall or obstruction which may cause discharged material to ricochet back toward the operator.
8. Always wear safety glasses or safety goggles during operation and while performing an adjustment or repair to protect your eyes. Thrown objects which ricochet can cause serious injury to the eyes.
9. Wear sturdy, rough-soled work shoes and close-fitting slacks and shirts. Loose fitting clothes and jewelry can be caught in movable parts. Never operate this machine in bare feet or sandals.
10. Be aware of the mower and attachment discharge direction and do not point it at anyone. Do not operate the mower without the discharge cover or entire grass catcher in its proper place.
11. Do not put hands or feet near rotating parts or under the cutting deck. Contact with the blade(s) can amputate hands and feet.
12. A missing or damaged discharge cover can cause blade contact or thrown object injuries.
13. Stop the blade(s) when crossing gravel drives, walks, or roads and while not cutting grass.
14. Watch for traffic when operating near or crossing roadways. This machine is not intended for use on any public roadway.
15. Do not operate the machine while under the influence of alcohol or drugs.
16. Mow only in daylight or good artificial light.
17. Never carry passengers.
18. Disengage blade(s) before shifting into reverse. Back up slowly. Always look down and behind before and while backing to avoid a back-over accident.

19. Slow down before turning. Operate the machine smoothly. Avoid erratic operation and excessive speed.
20. Disengage blade(s), set parking brake, stop engine and wait until the blade(s) come to a complete stop before removing grass catcher, emptying grass, unclogging chute, removing any grass or debris, or making any adjustments.
21. Never leave a running machine unattended. Always turn off blade(s), place transmission in neutral, set parking brake, stop engine and remove key before dismounting.
22. Use extra care when loading or unloading the machine into a trailer or truck. This unit should not be driven up or down ramp(s), because the unit could tip over, causing serious personal injury. The unit must be pushed manually on ramp(s) to load or unload properly.
23. Muffler and engine become hot and can cause a burn. Do not touch.
24. Check overhead clearances carefully before driving under low hanging tree branches, wires, door openings etc., where the operator may be struck or pulled from the unit, which could result in serious injury.
25. Disengage all attachment clutches, depress the brake pedal completely and shift into neutral before attempting to start engine.
26. Your machine is designed to cut normal residential grass of a height no more than 10". Do not attempt to mow through unusually tall, dry grass (e.g., pasture) or piles of dry leaves. Dry grass or leaves may contact the engine exhaust and/or build up on the mower deck presenting a potential fire hazard.
27. Use only accessories and attachments approved for this machine by the machine manufacturer. Read, understand and follow all instructions provided with the approved accessory or attachment.
28. Data indicates that operators, age 60 years and above, are involved in a large percentage of riding mower-related injuries. These operators should evaluate their ability to operate the riding mower safely enough to protect themselves and others from serious injury.
29. If situations occur which are not covered in this manual, use care and good judgment. Contact a Troy-Bilt Service Dealer for assistance.

SLOPE OPERATION

Slopes are a major factor related to loss of control and tip-over accidents which can result in severe injury or death. All slopes require extra caution. If you cannot back up the slope or if you feel uneasy on it, do not mow it.

For your safety, use the slope gauge included as part of this manual to measure slopes before operating this unit on a sloped or hilly area. If the slope is greater than 15 degrees as shown on the slope gauge, do not operate this unit on that area or serious injury could result.

DO:

1. Mow up and down slopes, not across. Exercise extreme caution when changing direction on slopes.
2. Watch for holes, ruts, bumps, rocks, or other hidden objects. Uneven terrain could overturn the machine. Tall grass can hide obstacles.
3. Use slow speed. Choose a low enough speed setting so that you will not have to stop or shift while on the slope. Tires may lose traction on slopes even though the brakes are functioning properly. Always keep machine in gear when going down slopes to take advantage of engine braking action.
4. Follow the manufacturer's recommendations for wheel weights or counterweights to improve stability.
5. Use extra care with grass catchers or other attachments. These can change the stability of the machine.
6. Keep all movement on the slopes slow and gradual. Do not make sudden changes in speed or direction. Rapid transmission engagement or braking could cause the front of the machine to lift and rapidly flip over backwards which could cause serious injury.
7. Avoid starting or stopping on a slope. If tires lose traction, disengage the blade(s) and proceed slowly straight down the slope.

DO NOT:

1. Do not turn on slopes unless necessary; then, turn slowly and gradually downhill, if possible.
2. Do not mow near drop-offs, ditches or embankments. The mower could suddenly turn over if a wheel is over the edge of a cliff, ditch, or if an edge caves in.
3. Do not try to stabilize the machine by putting your foot on the ground.
4. Do not use a grass catcher on steep slopes.
5. Do not mow on wet grass. Reduced traction could cause sliding.
6. Do not shift to neutral and coast downhill. Doing so may cause the operator to lose control of the machine resulting in serious injury or death.
7. Do not tow heavy pull behind attachments (e.g. loaded dump cart, lawn roller, etc.) on slopes greater than 5 degrees. When going down hill, the extra weight tends to push the tractor and may cause you to lose control. (e.g. tractor may speed up, braking and steering ability are reduced, attachment may jack-knife and cause tractor to overturn).

CHILDREN

1. Tragic accidents can occur if the operator is not alert to the presence of children. Children are often attracted to the machine and the mowing activity. They do not understand the dangers. Never assume that children will remain where you last saw them.
 - a. Keep children out of the mowing area and in watchful care of a responsible adult other than the operator.
 - b. Be alert and turn machine off if a child enters the area.
 - c. Before and while backing, look behind and down for small children.
 - d. Never carry children, even with the blade(s) shut off. They may fall off and be seriously injured or interfere with safe machine operation.
 - e. Use extreme care when approaching blind corners, doorways, shrubs, trees or other objects that may block your vision of a child who may run into the machine.
 - f. **To avoid back-over accidents, always disengage the cutting blade(s) before shifting into reverse. The “Reverse Caution Mode” should not be used when children or others are around.**
 - g. Keep children away from hot or running engines. They can suffer burns from a hot muffler.
 - h. Remove key when machine is unattended to prevent unauthorized operation.
2. Never allow children under 14 years old to operate the machine. Children 14 years old and over should read and understand the operation instructions and safety rules in this manual and should be trained and supervised by a parent.

TOWING

1. Tow only with a machine that has a hitch designed for towing. Do not attach towed equipment except at the hitch point.
2. Follow the manufacturers recommendation for weight limits for towed equipment and towing on slopes.
3. Never allow children or others in or on towed equipment.
4. Do not tow heavy pull behind attachments (e.g. loaded dump cart, lawn roller, etc.) on slopes greater than 5 degrees. When going down hill, the extra weight tends to push the tractor and may cause you to loose control. (e.g. tractor may speed up, braking and steering ability are reduced, attachment may jack-knife and cause tractor to overturn).

5. Travel slowly and allow extra distance to stop.
6. On slopes, the weight of the towed equipment may cause loss of traction and loss of control.
7. Do not shift to neutral and coast downhill.

SERVICE

SAFE HANDLING OF GASOLINE:

1. **To avoid personal injury or property damage** use extreme care in handling gasoline. Gasoline is extremely flammable and the vapors are explosive. Serious personal injury can occur when gasoline is spilled on yourself or your clothes which can ignite. Wash your skin and change clothes immediately.
 - a. Use only an approved gasoline container.
 - b. Never fill containers inside a vehicle or on a truck or trailer bed with a plastic liner. Always place containers on the ground away from your vehicle before filling.
 - c. When practical, remove gas-powered equipment from the truck or trailer and refuel it on the ground. If this is not possible, then refuel such equipment on a trailer with a portable container, rather than from a gasoline dispenser nozzle.
 - d. Keep the nozzle in contact with the rim of the fuel tank or container opening at all times until fueling is complete. Do not use a nozzle lock-open device.
 - e. Extinguish all cigarettes, cigars, pipes and other sources of ignition.
 - f. Never fuel machine indoors.
 - g. Never remove gas cap or add fuel while the engine is hot or running. Allow engine to cool at least two minutes before refueling.
 - h. Never over fill fuel tank. Fill tank to no more than 1/2-inch below the bottom of the filler neck to allow space for fuel expansion.
 - i. Replace gasoline cap and tighten securely.
 - j. If gasoline is spilled, wipe it off the engine and equipment. Move unit to another area. Wait 5 minutes before starting the engine.
 - k. To reduce fire hazards, keep machine free of grass, leaves, or other debris build-up. Clean up oil or fuel spillage and remove any fuel soaked debris.
 - l. Never store the machine or fuel container inside where there is an open flame, spark or pilot light as on a water heater, space heater, furnace, clothes dryer or other gas appliances.
 - m. Allow a machine to cool at least 5 minutes before storing.

GENERAL SERVICE:

1. Never run an engine indoors or in a poorly ventilated area. Engine exhaust contains carbon monoxide, an odorless, and deadly gas.
2. Before cleaning, repairing, or inspecting, make certain the blade(s) and all moving parts have stopped. Remove the key to prevent unintended starting.
3. Periodically check to make sure the blades come to complete stop within approximately five (5) seconds after operating the blade disengagement control. If the blades do not stop within the this time frame, your unit should be serviced professionally by a Troy-Bilt Service Dealer.
4. Check brake operation frequently as it is subjected to wear during normal operation. Adjust and service as required.
5. Check the blade(s) and engine mounting bolts at frequent intervals for proper tightness. Also, visually inspect blade(s) for damage (e.g., excessive wear, bent, cracked). Replace the blade(s) with the original equipment manufacturer's (O.E.M.) blade(s) only. Use of parts which do not meet the original equipment specifications may lead to improper performance and compromise safety!
6. Mower blades are sharp. Wrap the blade or wear gloves, and use extra caution when servicing them.
7. Keep all nuts, bolts, and screws tight to be sure the equipment is in safe working condition.
8. Never tamper with the safety interlock system or other safety devices. Check their proper operation before each use.
9. After striking a foreign object, stop the engine, and remove the key. Thoroughly inspect the machine for any damage. Repair the damage before starting and operating.
10. Never attempt to make adjustments or repairs to the machine while the engine is running.
11. Grass catcher components and the discharge cover are subject to wear and damage which could expose moving parts or allow objects to be thrown.
12. For safety protection, frequently check components and replace immediately with original equipment manufacturer's (O.E.M.) parts only. Use of parts which do not meet the original equipment specifications may lead to improper performance and compromise safety!
13. Do not change the engine governor settings or over-speed the engine. The governor controls the maximum safe operating speed of the engine.
14. Maintain or replace safety and instruction labels as necessary (i.e. when scratched, damaged or missing).
15. Observe proper disposal laws and regulations for gas, oil, etc. to protect the environment.



WARNING: YOUR RESPONSIBILITY Restrict the use of this power machine to persons who agree to read, understand and follow the warnings and instructions in this manual and on the machine.

⚠ DANGER
AVOID SERIOUS INJURY OR DEATH
 • KEEP HANDS AND FEET AWAY FROM ROTATING PARTS.
 • REMOVE OBJECTS THAT CAN BE THROWN BY THE BLADE IN ANY DIRECTION. WEAR SAFETY GLASSES.
 • DO NOT MOW WHEN CHILDREN OR OTHERS ARE AROUND. NEVER CARRY CHILDREN EVEN WITH BLADES OFF.
 • USE EXTRA CAUTION ON SLOPES. DO NOT MOW SLOPES GREATER THAN 15°. MOW UP AND DOWN, NOT ACROSS. AVOID SUDDEN TURNS, USE LOW SPEED.
 S30015
 READ OPERATOR'S MANUAL. KEEP SAFETY DEVICES IN PLACE AND WORKING. MAX 15°

⚠ DANGER
KEEP HANDS AND FEET AWAY. DO NOT OPERATE MOWER UNLESS CHUTE DEFLECTOR OR ENTIRE GRASS CATCHER IS IN ITS PROPER PLACE.
 S30503
ASSEMBLE CHUTE DEFLECTOR TO THIS UNIT BEFORE OPERATING.

TO REDUCE THE RISK OF INJURY, DO NOT OPERATE UNLESS DISCHARGE COVER OR GRASS CATCHER IS IN ITS PROPER PLACE. IF DAMAGED, REPLACE IMMEDIATELY.

DANGER
KEEP HANDS and FEET AWAY

⚠ DANGER
ROTATING BLADES CAUSE SERIOUS INJURY OR DEATH
 • DO NOT MOW WHEN CHILDREN OR OTHERS ARE AROUND
 • NEVER CARRY CHILDREN EVEN WITH BLADE(S) OFF.
 • LOOK DOWN AND BEHIND BEFORE AND WHILE BACKING.
 • MOWING IN REVERSE IS NOT RECOMMENDED.

⚠ WARNING
TO AVOID SERIOUS INJURY OR DEATH
 • GO UP AND DOWN SLOPES, NOT ACROSS.
 • AVOID SUDDEN TURNS.
 • DO NOT OPERATE THE UNIT WHERE IT COULD SLIP OR TIP.
 • IF MACHINE STOPS GOING UPHILL, STOP BLADE(S) AND BACK DOWNHILL SLOWLY.
 • KEEP SAFETY DEVICES (GUARDS, SHIELDS, AND SWITCHES, ETC.) IN PLACE AND WORKING.
 • REMOVE OBJECTS THAT COULD BE THROWN BY THE BLADE(S).
 • KNOW LOCATION AND FUNCTION OF ALL CONTROLS.
 • BE SURE BLADE(S) AND ENGINE ARE STOPPED BEFORE PLACING HANDS OR FEET NEAR BLADE(S).
 • BEFORE LEAVING OPERATOR'S POSITION, DISENGAGE BLADE(S), ENGAGE PARKING BRAKE, SHUT OFF AND REMOVE KEY.
READ OPERATOR'S MANUAL

SECTION 2: SLOPE GAUGE

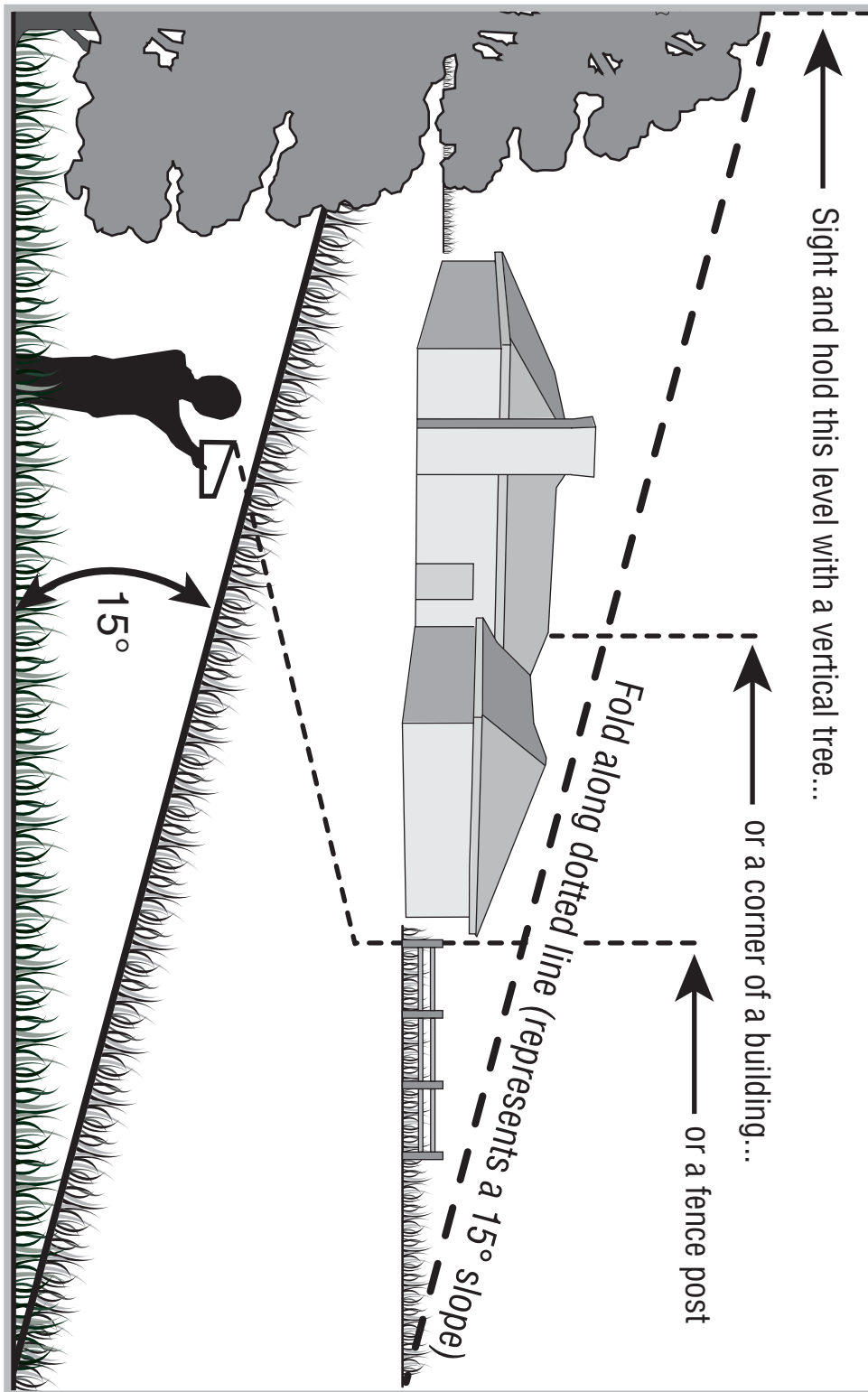

SECTION 3: TRACTOR SET-UP

Gas and Oil Fill-up

Use only clean, fresh (under 30 days old), unleaded gasoline. Fill tank to no more than 1/2 inch below the top of the filler neck to allow space for fuel expansion.



WARNING: Use extreme care when handling gasoline. Gasoline is extremely flammable and the vapors are explosive. Never fuel machine indoors or while the engine is hot or running. Extinguish cigarettes, cigars, pipes, and other sources of ignition before filling the fuel tank.

Use only clean, fresh (under 30 days old), unleaded gasoline. Fill tank to no more than 1/2 inch below the top of the filler neck to allow space for fuel expansion. See Figure 1.

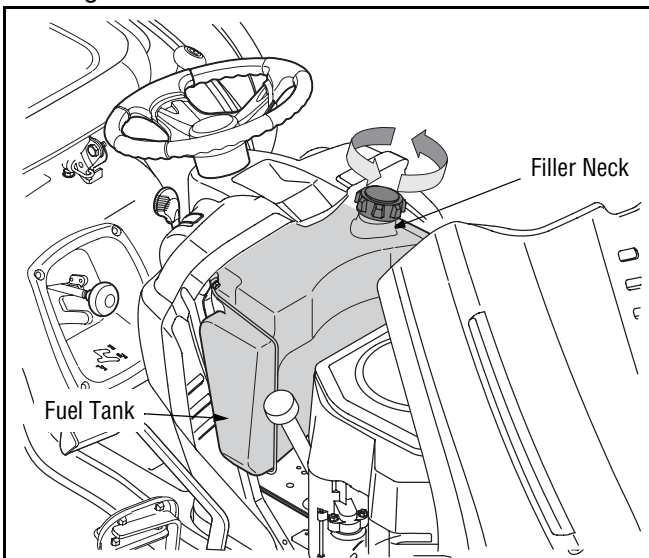

Figure 1

IMPORTANT: Your tractor is shipped with oil in the engine. However, you **MUST** check the oil level before operating. Refer to your engine manual for detailed instructions.

Shipping Brace Removal



WARNING: Make sure the engine is off, set the parking brake and remove the ignition key before removing the shipping brace.

1. Locate the shipping brace, if present, and warning tag found on the right side of the cutting deck.
2. While holding the discharge chute with your left hand, remove the shipping brace with your right hand by grasping it between your thumb and index finger and rotating it clockwise.

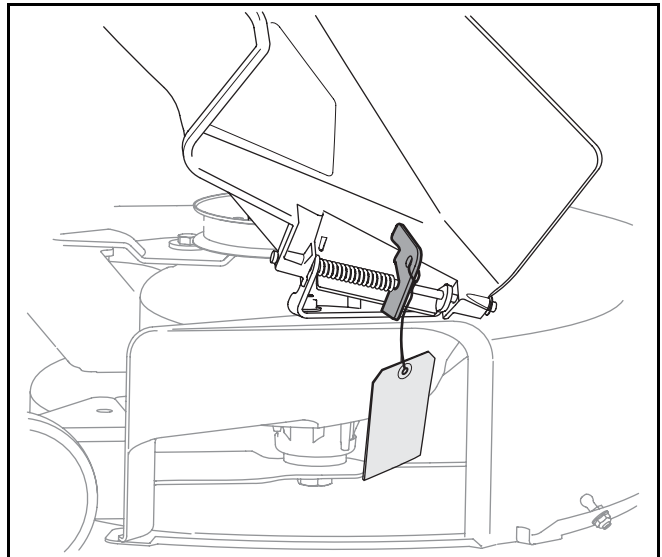

Figure 2



WARNING: The shipping brace, used for packaging purposes only, must be removed and discarded before operating your tractor.



WARNING: The mowing deck is capable of throwing objects. Failure to operate the riding mower without the discharge cover in the proper operating position could result in serious personal injury and/or property damage.

Tire Pressure



WARNING: Maximum tire pressure under any circumstances is 30 psi. Equal tire pressure should be maintained at all times.

The tires on your unit may be over-inflated for shipping purposes. Reduce the tire pressure before operating the tractor. Recommended operating tire pressure is approximately 10 p.s.i for the rear tires & 14 p.s.i. for the front tires. Check sidewall of tire for maximum p.s.i.

Attaching the Battery Cables

Tools Required

(1) 7/16" wrench



WARNING: California Proposition 65
Warning: Battery posts, terminals, and related accessories contain lead and lead compounds, chemicals known to the State of California to cause cancer and reproductive harm. *Wash hands after handling.*

NOTE: Your tractor's battery cables may have already be attached at the factory.

NOTE: The positive battery terminal is marked Pos. (+). The negative battery terminal is marked Neg. (-).

1. The positive cable (heavy red wire) is secured to the positive battery terminal (+) with a carriage bolt and hex nut at the factory. Make certain that the rubber boot covers the terminal to help protect it from corrosion.
2. Remove the carriage bolt and hex nut from the negative cable.
3. Remove the black plastic cover, if present, from the negative battery terminal and attach the negative cable (heavy black wire) to the negative battery terminal (-) with the bolt and hex nut.
4. Make certain the hold-down rod is in position over the battery, securing it in place. See Figure 3.

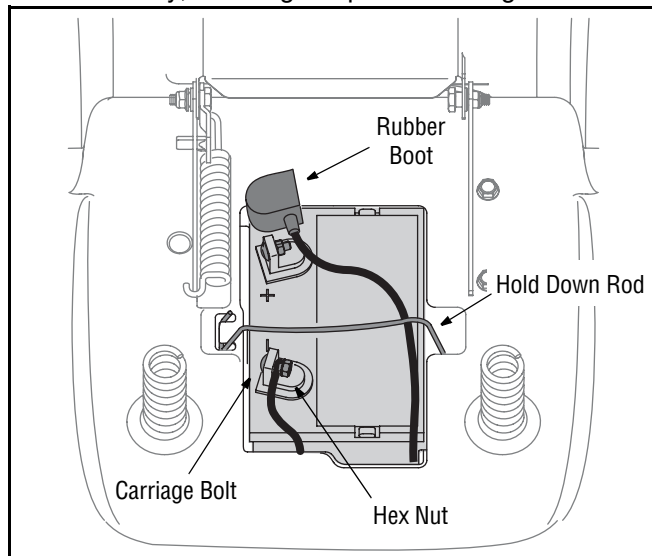

Figure 3

NOTE: If the battery is put into service after the date shown on top/side of battery, charge the battery as instructed on page 20 of this manual prior to operating the tractor.

Setting the Gauge Wheels

Select the height position of the cutting deck by placing the deck lift lever in any of the six different cutting height notches on the right fender.

Adjust the deck wheels so that they are between 1/4-inch and 1/2-inch above the ground as follows.



WARNING: Keep hands and feet away from the discharge opening of the cutting deck.

Place the tractor on a firm and level surface, preferably pavement. Refer to Figure 4, and proceed as follows:

- Place the tractor's deck lift handle in the normally desired mowing height setting, then check the gauge wheels for contact or excessive clearance with the surface below.

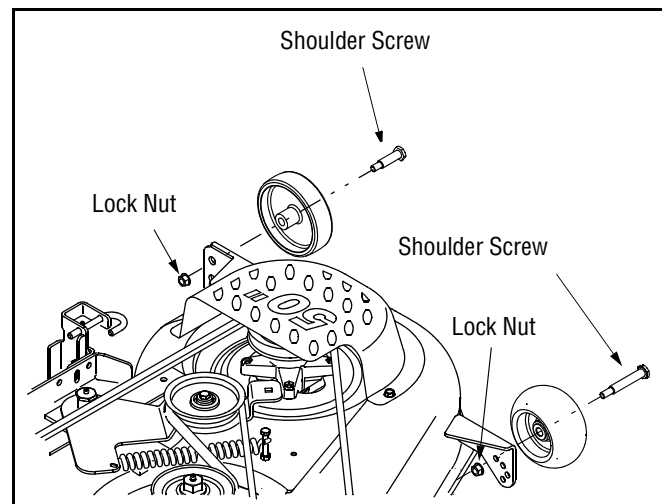

Figure 4

- If the wheels contact the surface adjust as follows:
 - a. Place the deck lift handle in its highest notch.
 - b. Remove the rear gauge wheels by removing the lock nuts and shoulder screws which secure them to the deck.
 - c. Remove the lock nuts and shoulder screws which secure the front gauge wheels.
 - d. Place the deck lift handle in the desired mowing height setting.
 - e. Insert the shoulder screw with the rear gauge wheel into the index hole that leaves approximately 1/2-inch between the bottom of the wheel and the pavement.
 - f. Note the position of the index hole used; then install the other rear gauge wheel and the front ball wheels into the corresponding index hole of the other gauge wheel brackets.
- If the gauge wheels have excessive clearance with the surface below, lower the wheels to the index hole that provides the approximate 1/2" clearance as described above.

Refer to **Leveling the Deck** on page 16 of this manual for more detailed instructions regarding deck adjustments.

SECTION 4: KNOW YOUR GARDEN TRACTOR

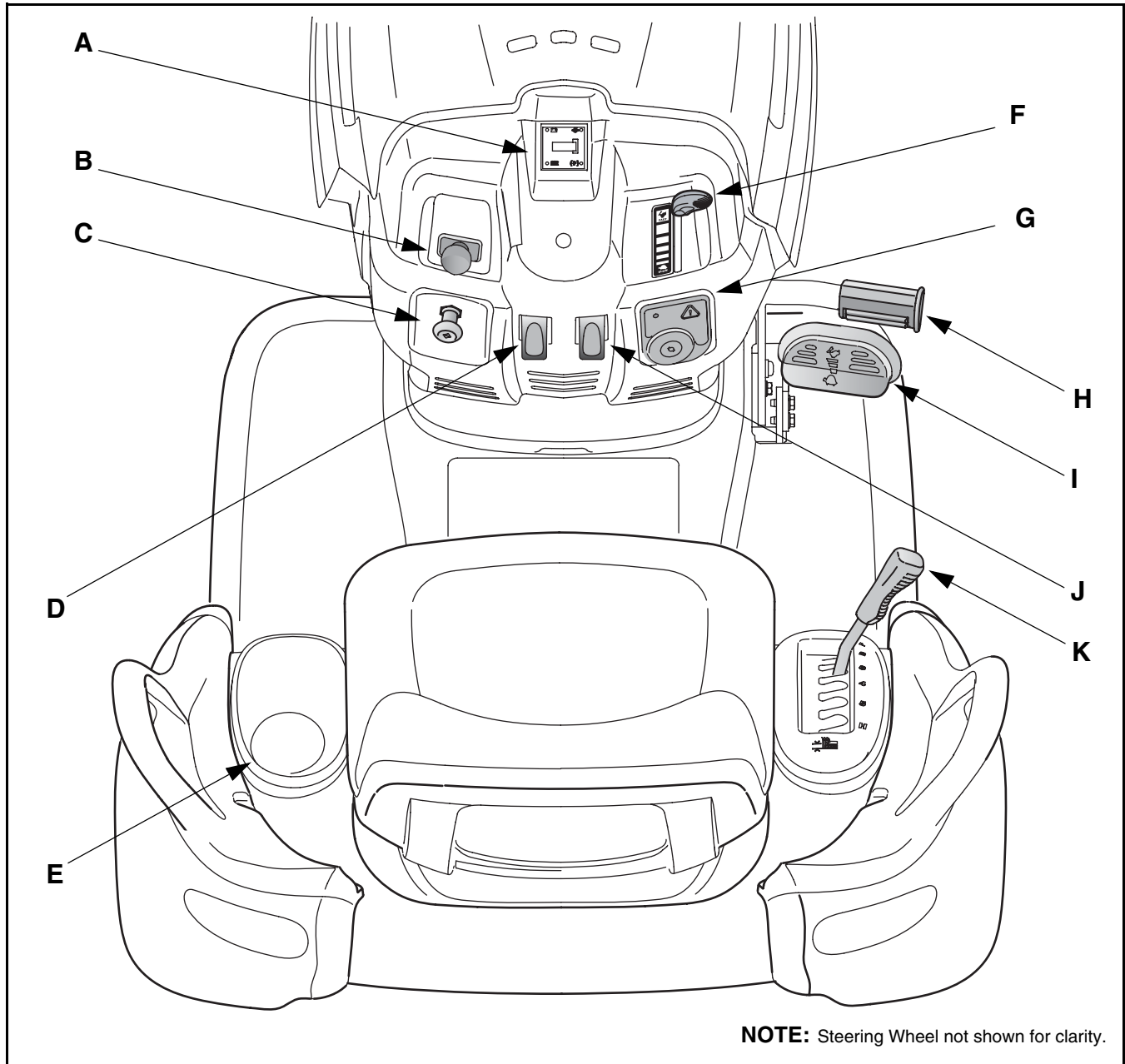

Figure 5

- | | |
|--|--------------------------|
| A Systems Indicator Monitor/Hour Meter | G Ignition Switch Module |
| B PTO (Blade Engage) Knob | H Brake Pedal |
| C Choke Control | I Drive Pedal |
| D Parking Brake Lever | J Cruise Control Lever |
| E Cup Holder | K Deck Lift Lever |
| F Throttle Control | |

NOTE: Any reference in this manual to the RIGHT or LEFT side of the tractor is observed from operator's position.

Throttle Control

The throttle control lever is located on the right side of the tractor's dash panel. This lever controls the speed of the engine. When set in a given position, the throttle will maintain a uniform engine speed.

IMPORTANT: When operating the tractor with the cutting deck engaged, be certain that the throttle lever is **always** in the FAST (rabbit) position.

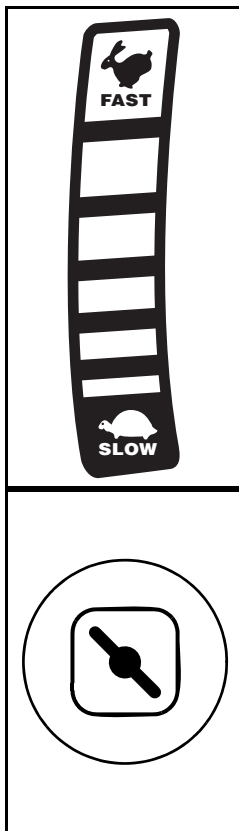

Choke Control

The choke control can be found on the left side of the dash panel and is activated by pulling the knob outward. Activating the choke control closes the choke plate on the carburetor and aids in starting the engine. Refer to **Starting The Engine** on page 14 of this manual for detailed starting instructions.

Brake Pedal

The brake pedal is located on the right front side of the tractor above the drive pedal along the running board. The brake pedal can be used for sudden stops or setting the parking brake.

NOTE: The brake pedal must be fully depressed when starting the tractor.

Shift Lever

The shift lever is located on the front of the fender between the operator's legs and has four positions. Placing the lever in FORWARD—HI, FORWARD—LO or REVERSE engages the tractor's transmission. When the shift lever is in none of these positions, the tractor's transmission is in NEUTRAL. The tractor must not be in motion when moving the shift lever. Always bring the tractor to a complete stop prior to moving the shift lever from FORWARD—HI to FORWARD—LO or vice-versa.

IMPORTANT: Never force the shift lever. Doing so may result in serious damage to the tractor's transmission.

Deck Lift Lever

Found on your tractor's right fender, the deck lift lever is used to change the height of the cutting deck. To use, move the lever to the left, then place in the notch best suited for your application.

Ignition Switch Module



WARNING: Never leave a running machine unattended. Always disengage PTO, move shift lever into neutral position, set parking brake, stop engine and remove key to prevent unintended starting.

To start the engine, insert the key into the ignition switch and turn clockwise to the **START** position. Release the key into the **NORMAL MOWING MODE** position once the engine has fired.

To stop the engine, turn the ignition key counterclockwise to the **STOP** position. See Figure 6.

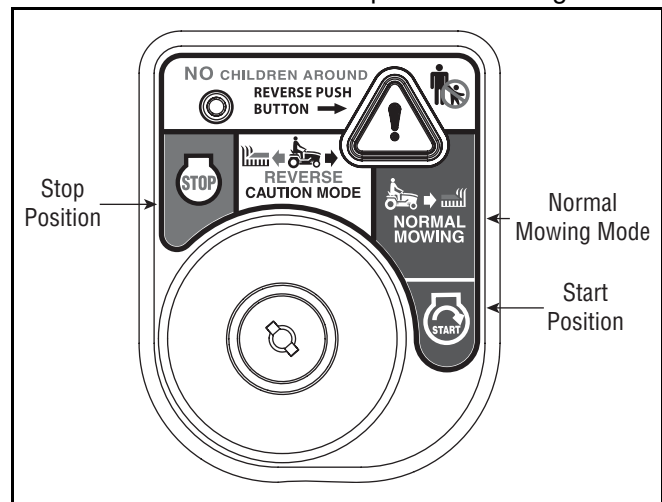

Figure 6

IMPORTANT: Prior to operating the tractor, refer to both **Safety Interlock Switches** on page 13 and **Starting The Engine** on page 14 of this manual for detailed instructions regarding the Ignition Switch Module and operating the tractor in **REVERSE CAUTION MODE**.

Drive Pedal

The drive pedal is located below the brake pedal on the right front side of the tractor along the running board. Depress the drive pedal with your right foot when the tractor shift lever is in either FORWARD or REVERSE to cause the tractor to move.

Ground speed is also controlled with the drive pedal. The further down the pedal is depressed, the faster the tractor will travel. The pedal will return to its original position when released.

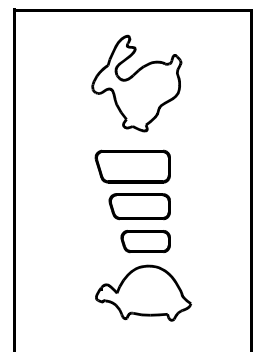

Systems Indicator Monitor / Hour Meter

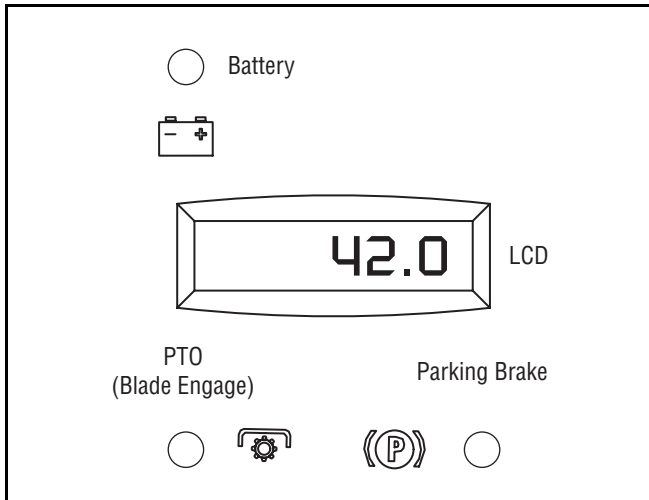

LCD

Located in the center of the tractor's console, the systems indicator monitor records, and displays on its LCD, hours of tractor operation whenever the ignition key is rotated out of the STOP position.

The Indicator Monitor will also remind the operator of maintenance intervals for changing the engine oil. The LCD will alternately flash the recorded hours, "CHG" and "OIL" for five minutes, after every 50 hours of recorded operation elapse. The maintenance interval lasts for two hours (from 50-52, 100-102, 150-152, etc.). The LCD will also flash as described above for five minutes every time the tractor's engine has been started during this maintenance interval. Before the interval expires, change the crankcase oil level as instructed in the **MAINTENANCE** section of this manual.

Brake

If the Brake light illuminates when attempting to start the tractor's engine, depress the brake pedal.

PTO (Blade Engage)

If the PTO light illuminates when attempting to start the tractor's engine, move the PTO knob into the disengaged (OFF) position.

Battery

It is normal for the Battery light to illuminate while the engine is **cranking** during start-up, but if it illuminates during operation, **while the engine is running**, the battery is in need of a charge or the engine's charging system is not generating sufficient amperage. Refer to the **MAINTENANCE** section of this manual for the proper battery charging procedure or have the charging system checked by an authorized *Troy-Bilt* Service Dealer.

Electric PTO / Blade Engage Knob

To engage the power to the cutting deck or other (separately available) attachments, pull outward on the PTO/Blade Engage knob. Push the PTO/Blade Engage knob inward to disengage the power to the cutting deck or other (separately available) attachments.

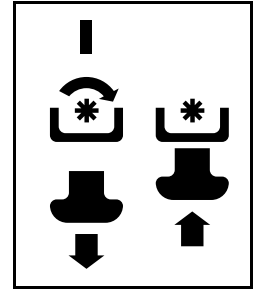

NOTE: The PTO/Blade Engage knob **must** be in the disengaged (OFF) position when starting the engine.

Cruise Control Lever

The cruise control lever is located on the tractor dash panel, below the steering wheel. Push the cruise control lever downward while traveling forward at a desired speed. While holding the lever down, release pressure from the drive pedal.

This will engage the cruise control and allow the tractor to remain at that speed without applying pressure to the drive pedal. Depress the brake pedal or the drive pedal to deactivate cruise control. Refer to page 15 for detailed instructions regarding cruise control.

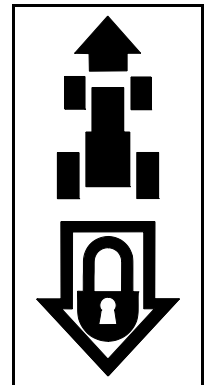

NOTE: Cruise control **cannot** be engaged at the tractor's fastest ground speed. If the operator should attempt to do so, the tractor will automatically decelerate to the fastest optimal mowing ground speed.

Parking Brake Lever

To set the parking brake, fully depress the brake pedal and push the parking brake lever down. Hold the lever down while taking your foot off the brake pedal. Both the parking brake lever and the brake pedal will then stay depressed. To release the parking brake, depress the brake pedal slightly. The parking brake lever will then return to its original position.

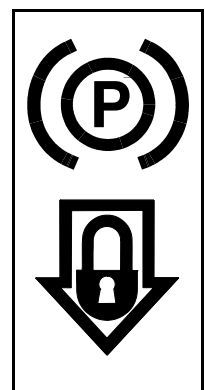

IMPORTANT: Always set the parking brake when leaving the tractor unattended.

SECTION 5: OPERATING YOUR GARDEN TRACTOR

Safety Interlock System

This tractor is equipped with a safety interlock system for the protection of the operator. Before each use, check the safety interlock system for proper operation. If the interlock system should ever malfunction, do not operate the tractor. Contact a *Troy-Bilt* service dealer.

- The safety interlock system prevents the engine from cranking or starting unless the parking brake is engaged, and the PTO (Blade Engage) knob is in the disengaged (OFF) position. To check for proper operation, move the PTO (Blade Engage) knob into the engaged (ON) position and release the parking brake. Attempts to start the tractor's engine should fail.
- The engine will automatically shut off if the operator leaves the seat before engaging the parking brake. To check for proper operation, start the tractor's engine, release the parking brake and momentarily raise yourself from the seat. The engine should stall.
- The engine will automatically shut off if the operator leaves the tractor's seat with the PTO (Blade Engage) knob in the engaged (ON) position, regardless of whether the parking brake is engaged. To check for proper operation, start the tractor's engine, move the PTO (Blade Engage) knob in the engaged (ON) position and momentarily raise yourself from the seat. The engine should stall.
- With the ignition key in the **NORMAL MOWING** position, the PTO clutch will automatically shut off if the PTO (Blade Engage) knob is moved into the engaged (ON) position with the shift lever in Reverse and the drive pedal depressed. To check for proper operation, start the tractor's engine with the ignition key in the **NORMAL MOWING** position, move the PTO (Blade Engage) knob into the engaged (ON) position, place the shift lever into REVERSE and depress the drive pedal. The cutting deck should disengage.



WARNING: Do not operate the tractor if the interlock system is malfunctioning. This system was designed for your safety and protection.

Reverse Caution Mode

The **REVERSE CAUTION MODE** position of the key switch module allows the tractor to be operated in reverse with the blades (PTO) engaged.

IMPORTANT: *Mowing in reverse is not recommended.*



WARNING: Use extreme caution while operating the tractor in the **REVERSE CAUTION MODE**. Always look down and behind before and while backing. Do not operate the tractor when children or others are around. Stop the tractor immediately if someone enters the area.

To use the **REVERSE CAUTION MODE:**

IMPORTANT: *The operator MUST be seated in the tractor seat.*

1. Start the engine as previously instructed in this Operator's Manual.
2. Turn the key from the **NORMAL MOWING** (Green) position to the **REVERSE CAUTION MODE** (Yellow) position of the key switch module. See Figure 7.
3. Depress the **REVERSE PUSH BUTTON** (Orange, Triangular Button) at the top, right corner of the key switch module. The red indicator light at the top, left corner of the key switch module will be **ON** while activated. See Figure 7.
4. Once activated (indicator light **ON**), the tractor can be driven in reverse with the cutting blades (PTO) engaged.
5. Always look down and behind before and while backing to make sure no children are around.
6. After resuming forward motion, return the key to the **NORMAL MOWING** position.

IMPORTANT: The **REVERSE CAUTION MODE** will remain activated until:

- a. The key is placed in either the **NORMAL MOWING** position or **STOP** position.
- b. The operator leaves the seat.

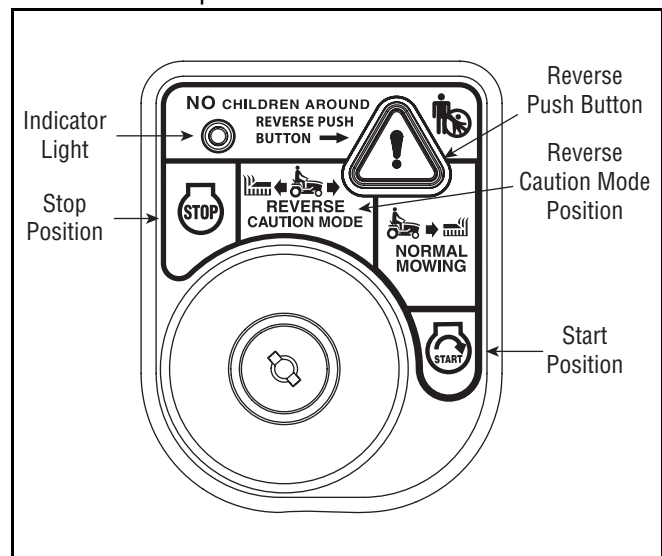

Figure 7

Starting the Engine



WARNING: Do not operate the tractor if the interlock system is malfunctioning. This system was designed for your safety and protection.

NOTE: Refer to the **TRACTOR SET-UP** on page 8 of this manual for Gasoline and Oil fill-up instructions.

1. Insert the tractor key into the ignition switch module.
2. Place the PTO (Blade Engage) knob in the disengaged (OFF) position.
3. Engage the tractor's parking brake.
4. Activate the choke control.
5. Turn the ignition key clockwise to the START position. After the engine starts, release the key. It will return to the **NORMAL MOWING** position.

IMPORTANT: Do NOT hold the key in the START position for longer than ten seconds at a time. Doing so may cause damage to your engine's electric starter.

6. After the engine starts, deactivate the choke control.

NOTE: Do NOT leave the choke control on while operating the tractor. Doing so will result in a "rich" fuel mixture and cause the engine to run poorly.

Stopping the Engine



WARNING: If you strike a foreign object, stop the engine and remove the key. Thoroughly inspect the machine for any damage. Repair the damage before restarting and operating

1. If the blades are engaged, place the PTO/Blade Engage knob in the disengaged (OFF) position.
2. Position the throttle/choke control between half-throttle and the FAST (rabbit) position
3. Turn the ignition key counterclockwise to the STOP position.
4. Remove the key from the ignition switch to prevent unintended starting.

Using the Deck Lift Lever

To raise the cutting deck, move the deck lift lever to the left, then place it in the notch best suited for your application.

Driving The Tractor



WARNING: Avoid sudden starts, excessive speed and sudden stops.



WARNING: Do not leave the seat of the tractor without first placing the PTO (Blade Engage) knob in the disengaged (OFF) position, depressing the brake pedal and engaging the parking brake. If leaving the tractor unattended, also turn the ignition key off and remove the key.

1. Depress the brake pedal to release the parking brake and let the pedal up.
2. Move the throttle/choke control into the FAST (rabbit) position.

IMPORTANT: Do NOT use the shift lever to change the direction of travel when the tractor is in motion. Always use the brake pedal to bring the tractor to a complete stop before shifting.

3. To move forward, place the shift lever in the FORWARD—HI or FORWARD—LO position, then slowly depress the drive pedal until the desired speed is achieved.

NOTE: Operate the tractor with the shift lever in the FORWARD—LO position when using ground-engaging attachments or when towing a cart.

4. To move in reverse, place the shift lever in the REVERSE position, check that the area behind is clear then slowly depress the drive pedal.

Driving On Slopes

Refer to the **SLOPE GAUGE** on page 7 to help determine slopes where you may operate the tractor safely.



WARNING: Do not mow on inclines with a slope in excess of 15 degrees (a rise of approximately 2-1/2 feet every 10 feet). The tractor could overturn and cause serious injury.

- Mow up and down slopes, NEVER across.
- Exercise extreme caution when changing direction on slopes.
- Watch for holes, ruts, bumps, rocks, or other hidden objects. Uneven terrain could overturn the machine. Tall grass can hide obstacles.
- Avoid turns when driving on a slope. If a turn must be made, turn down the slope. Turning up a slope greatly increases the chance of a roll over.
- Avoid stopping when driving up a slope. If it is necessary to stop while driving up a slope, start up smoothly and carefully to reduce the possibility of flipping the tractor over backward.

Setting The Cruise Control

NOTE: The cruise control feature should only be utilized while traveling in the forward direction.

1. Slowly depress the drive pedal until the desired speed is achieved.
2. Lightly depress the cruise control lever.
3. While continuing to hold the cruise lever down, lift your foot from the drive pedal (you should feel the cruise latch engage).
4. Once engaged, the cruise control lever and the drive pedal will lock in the “down” position, and the tractor will maintain the same forward speed.

NOTE: Cruise control can not be set at the tractor's fastest ground speed. If the operator should attempt to do so, the tractor will automatically decelerate to the fastest optimal mowing ground speed.

To disengage the cruise control, either:

- Depress the brake pedal to disengage the cruise control and stop the tractor, or
- Lightly depress the drive pedal.

To change to the reverse direction when operating with cruise control, depress the brake pedal to disengage the cruise control and bring the tractor to a complete stop. Place the shift lever in the REVERSE position and depress the drive pedal.

Engaging the Parking Brake

To engage the parking brake:

1. Fully depress the brake pedal and hold it while gently pushing the parking brake lever downward.
2. Hold the parking brake lever down while removing your foot from the brake pedal.
3. Once engaged, the parking brake lever and the brake pedal will lock in the “down” position.

To disengage the parking brake, slightly depress the brake pedal.

NOTE: The parking brake must be engaged if the operator leaves the seat with the engine running or the engine will automatically shut off.

Engaging the PTO (Blades)

Engaging the PTO transfers power to the cutting deck or other (separately available) attachments. To engage the PTO, proceed as follows:

1. Move the throttle control lever to the FAST (rabbit) position.
2. Pull the PTO/Blade Engage knob outward into the engaged (ON) position. See Figure 8.
3. Keep the throttle lever in the FAST (rabbit) position for the most efficient use of the cutting deck or other (separately available) attachments.

IMPORTANT: With the ignition key in the **NORMAL MOWING** position, the PTO clutch will automatically shut off if the PTO (Blade Engage) knob is moved into the engaged (ON) position with the shift lever in Reverse. Refer to **Safety Interlock System** on page 13.

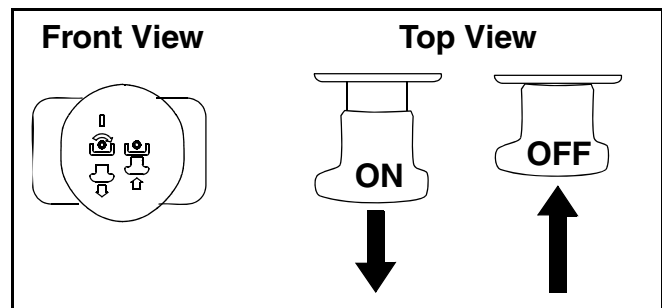

Figure 8

Mowing



WARNING: To help avoid blade contact or a thrown object injury, keep bystanders, helpers, children and pets at least 75 feet from the machine while it is in operation. Stop machine if anyone enters the area.

This tractor is equipped with one of *Troy-Bilt's* quality cutting decks. The following information will be helpful when using the cutting deck with your tractor.



WARNING: Plan your mowing pattern to avoid discharge of materials toward roads, sidewalks, bystanders and the like. Also, avoid discharging material against a wall or obstruction which may cause discharged material to ricochet back toward the operator.

- Do not mow at high ground speed, especially if a mulch kit or grass collector is installed.
- For best results it is recommended that the first two laps be cut with the discharge thrown towards the center. After the first two laps, reverse the direction to throw the discharge to the outside for the balance of cutting. This will give a better appearance to the lawn.
- Do not cut the grass too short. Short grass invites weed growth and yellows quickly in dry weather.
- Mowing should always be done with the engine at full throttle.
- Under heavier conditions it may be necessary to go back over the cut area a second time to get a clean cut.
- Do NOT attempt to mow heavy brush and weeds and extremely tall grass. Your tractor is designed to mow lawns, NOT clear brush.
- Keep the blades sharp and replace the blades when worn. Refer to **Cutting Blades** on page 19 of this manual for proper blade sharpening instructions.

SECTION 6: MAKING ADJUSTMENTS



WARNING: Never attempt to make any adjustments while the engine is running,

Leveling the Deck

NOTE: Check the tractor's tire pressure before performing any deck leveling adjustments. Refer to *Tires* on page 19 for information regarding tire pressure.

Front To Rear

The front of the cutting deck is supported by a stabilizer bar that can be adjusted to level the deck from front to rear. The front of the deck should be between 1/4-inch and 3/8-inch lower than the rear of the deck. Adjust if necessary as follows:

1. With the tractor parked on a firm, level surface, place the deck lift lever in the top notch (highest position) and rotate the blade nearest the discharge chute so that it is parallel with the tractor.
2. Measure the distance from the front of the blade tip to the ground and the rear of the blade tip to the ground.
3. The first measurement taken should be between 1/4" and 3/8" less than the second measurement.
4. Determine the approximate distance necessary for proper adjustment and proceed, if necessary, to the next step.
5. From the front of the tractor, loosen the outermost hex lock nut on the end of the deck hanger rod. See Figure 9.
6. Tighten the inner hex nut front against the front hanger bracket to raise the front of the deck; loosen the hex nut to lower the front of the deck. See Figure 9.

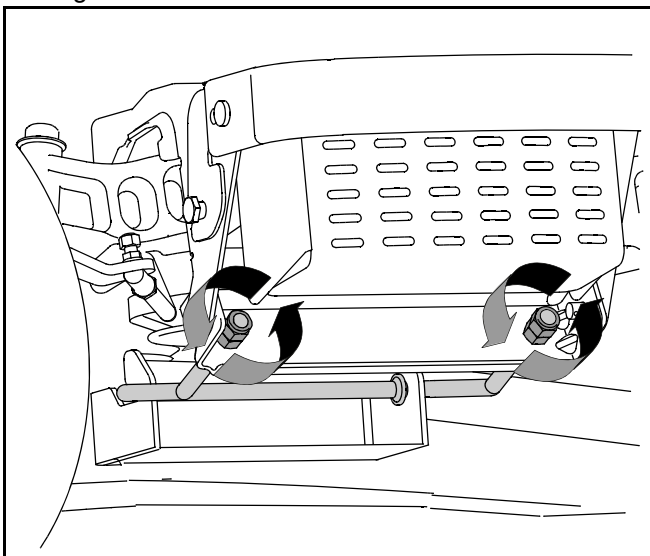

Figure 9

7. Retighten the two lock nuts against the inner hex nuts when proper adjustment is achieved.

Side to Side

If the cutting deck appears to be mowing unevenly, a side to side adjustment can be performed. Adjust if necessary as follows:

1. With the tractor parked on a firm, level surface, place the deck lift lever in the top notch (highest position) and rotate both blades so that they are perpendicular with the tractor.
2. Measure the distance from the outside of the left blade tip to the ground and the distance from the outside of the right blade tip to the ground. Both measurements taken should be equal. If they're not, proceed to the next step.
3. Loosen, but do NOT remove, the hex bolt on the left deck hanger bracket. See Figure 10.

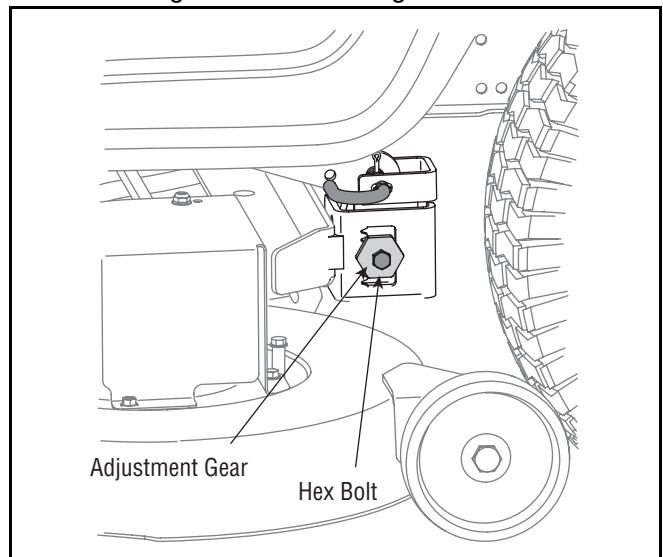

Figure 10

4. Balance the deck by using a wrench to turn the adjustment gear (See Figure 10) up or down.
5. The deck is properly balanced when both blade tip measurements taken earlier are equal.
6. Retighten the hex bolt on the left deck hanger bracket when proper adjustment is achieved.

Parking Brake Adjustment



WARNING: Never attempt to adjust the brakes while the engine is running. Always disengage PTO, move shift lever into neutral position, stop engine and remove key to prevent unintended starting.

If the tractor does not come to a complete stop when the brake pedal is completely depressed, or if the tractor's rear wheels can roll with the parking brake applied, the brake is in need of adjustment. The brake disc can be found on the right side of the transmission in the rear of the tractor. Adjust if necessary as follows:

1. Looking at the transmission from the rear of the tractor, locate the compression spring and brake disc. See Figure 11.

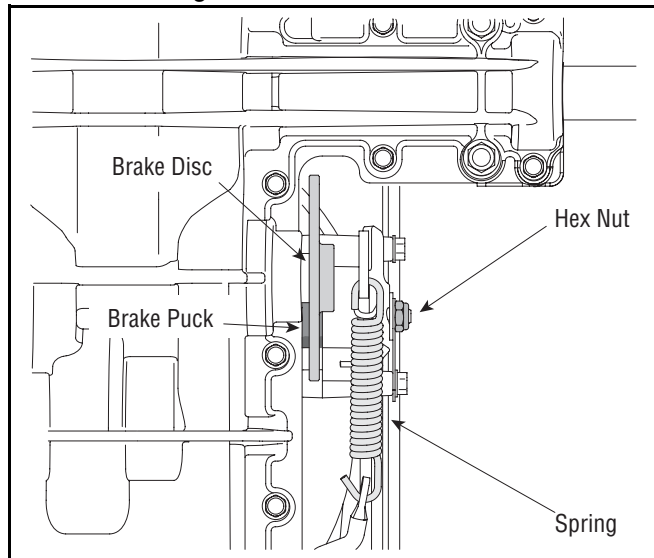

Figure 11

2. Loosen, but do NOT remove, the hex nut found on the right side of the brake assembly. See Figure 11.
3. Insert a feeler gauge (set at .011") between the brake disc and the brake puck.

NOTE: If a feeler gauge is unavailable, a typical business card is approximately .011" thick.

4. Retighten the hex nut loosened earlier, leaving a .011" gap between the brake disc and the brake puck.

Seat Adjustment



WARNING: Before operating this machine, make sure the seat is engaged in the seat stop, stand behind the machine and pull back on seat until fully engaged into stop.

To adjust the position of the seat, move the seat adjustment lever (Refer to Figure 5 on Page 10) to the left and slide the seat forward or rearward. Make sure seat is locked into position before operating the tractor.

Steering Adjustment

If the tractor turns tighter in one direction than the other, or if the ball joints are being replaced due to damage or wear, the steering drag links may need to be adjusted.

Adjust the drag links so that equal lengths are threaded into the ball joint on the left side and the ball joint on the right side:

1. Loosen the jam nut found on the drag link at the rear of the ball joint. See Figure 12.

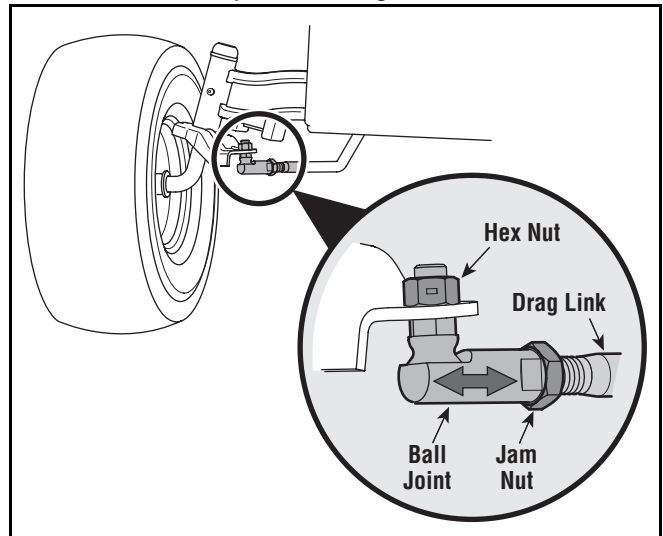

Figure 12

2. Remove the hex nut on the top of ball joint. See Figure 12.
3. Thread the ball joint toward the jam nut to shorten the drag link. Thread the ball joint away from the jam nut to lengthen the drag link.
4. Replace hex nut and lock washer and retighten the jam nut after proper adjustment is achieved.

NOTE: Threading the ball joints too far onto the drag links will cause the front tires to "toe-in" too far. Proper toe-in is between 1/16" and 5/16".

Front tire toe-in can be measured as follows:

1. Place the steering wheel in position for straight ahead travel.
2. In front of the axle, measure the distance horizontally from the inside of the left rim to the inside of the right rim. Note the distance.
3. Behind the axle, measure the distance horizontally from the inside of the left rim to the inside of the right rim. Note the distance.
4. The measurement taken in front of the axle should be between 1/16" and 5/16" less than the measurement taken behind the axle.
5. Adjust if necessary.

SECTION 7: MAINTAINING YOUR GARDEN TRACTOR



WARNING: Before performing any maintenance or repairs, disengage PTO, set parking brake, stop engine and remove key to prevent unintended starting.

Engine

Refer to the engine manual for maintenance details.

- Check engine oil level before each use as instructed in the engine manual.

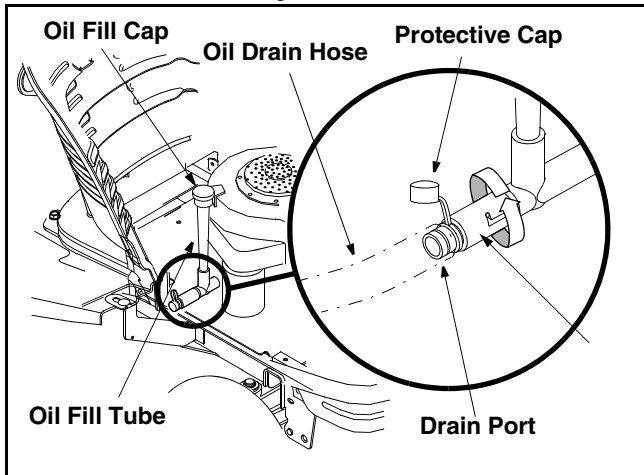

Figure 13

Changing Engine Oil

NOTE: Depending on the engine model found on your tractor, it may be necessary to remove the tractor's side panel in order to replace the oil filter (if so equipped).

- Unscrew oil fill cap and remove dipstick from the oil fill tube. See Figure 13.
- Pop open the protective cap on the end of the oil drain valve to expose the drain port. See Figure 13.
- Push the oil drain hose (packed with this manual) onto the oil drain port. Route the opposite end of the hose into an appropriate oil collection container with a capacity great enough to collect the used oil (approximately 64 oz.).
- Push the oil drain valve in slightly, then rotate counterclockwise and pull outward to begin draining oil. See Figure 13.
- Service the **oil filter** (if so equipped) as instructed in the engine manual.
- Perform the above steps in the opposite order after oil has finished draining.
- Refill the engine with new motor oil.

IMPORTANT: Refer to the engine manual for details about quantity and proper weight of motor oil.

Air Cleaner

- Service the pre-cleaner, if so equipped, and cartridge/air cleaner element as instructed in the engine manual.

Spark Plugs

- Clean the spark plugs and reset the gap once a season. Spark plug replacement is recommended at the start of each mowing season. Refer to the engine manual for correct plug type and gap specifications.

Cleaning the Engine and Deck

- Promptly wipe off any fuel or oil spilled on the machine.
- Do not allow grass, leaves, and dirt to accumulate around the cooling fins of the engine or on any other part of the machine, especially the pulleys and other moving parts.

IMPORTANT: The use of a pressure washer to clean your tractor is not recommended.

Lubrication



WARNING: Before lubricating, repairing, or inspecting, always disengage PTO, set parking brake, stop engine and remove key to prevent unintended starting.

Engine

Lubricate the engine with motor oil as instructed in the engine manual.

Wheels

The wheels should be removed from the axles once a season. Lubricate the axles and the rims well with an all-purpose grease before re-installing them.

Pivot Points & Linkage

Lubricate all the pivot points on the drive system, parking brake and lift linkage at least once a season with light oil.

Deck Idler

A grease fitting can be found on the pivoting idler bracket on the deck. Lubricate with a No. 2 multi-purpose grease applied with a grease gun after every 25 hours of tractor operation.

Deck Spindles

Grease fittings can be found on the front of each deck spindle. After every 25 hours of tractor operation, lubricate with 251H EP grease or an equivalent No. 2 multi-purpose lithium grease. Using a grease gun, apply two strokes (minimum) or sufficient grease to each spindle.

Transmission

The hydrostatic transmission is sealed at the factory. Oil level cannot be checked nor can the oil be changed.

SECTION 8: SERVICE



WARNING: Before servicing, repairing, or inspecting, always disengage PTO, set parking brake, stop engine and remove key to prevent unintended starting.

Tires



WARNING: Never exceed the maximum inflation pressure shown on the sidewall of the tire.

The recommended operating tire pressure is approximately 10 psi for the rear tires and 14 psi for the front tires. Do not overinflate. Uneven tire pressure could cause the cutting deck to mow unevenly.

Fuse

A 20 amp fuse is installed in your tractor's wiring harness to protect the tractor's electrical system from damage caused by excessive amperage.

If the electrical system does not function, or your tractor's engine will not crank, first check to be certain that the fuse has not blown.

It can be found under the hood mounted between the dash panel and fuel tank on the right-hand support bar.

IMPORTANT: Always use a 20 amp fuse for replacement.

Cutting Blades



WARNING: Be sure to shut the engine off, and remove ignition key to prevent unintended starting before removing the cutting blade(s) for sharpening or replacement. Protect your hands by using heavy gloves when grasping the blade.



WARNING: Periodically inspect the blade adapter and/or spindle for cracks or damage, especially if you strike a foreign object. Replace immediately if damaged.

The blades may be removed as follows.

- Remove the deck from beneath the tractor, (refer to **Cutting Deck Removal** on page 20) then carefully flip the deck over to expose its underside.
- Place a block of wood between the center deck housing baffle and the cutting blade to act as a stabilizer. See Figure 14.

- Use a wrench to remove the hex flange nut that secures the blade to the spindle assembly. See Figure 14.

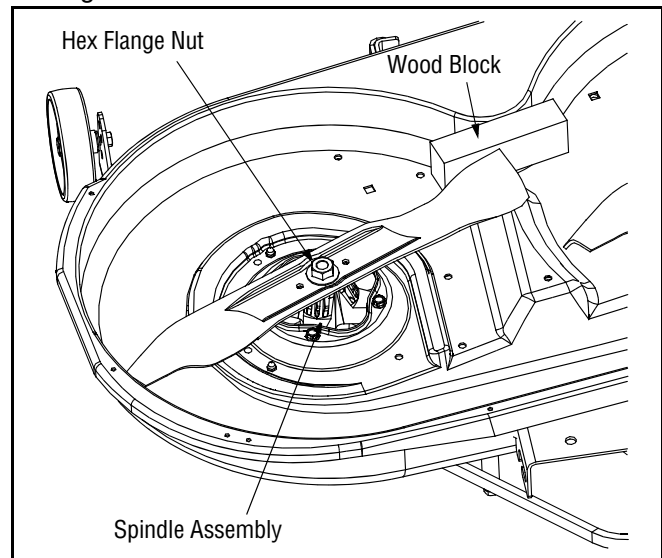

Figure 14

- To properly sharpen the cutting blades, remove equal amounts of metal from both ends of the blades along the cutting edges, parallel to the trailing edge, at a 25° to 30° angle. See Figure 15.

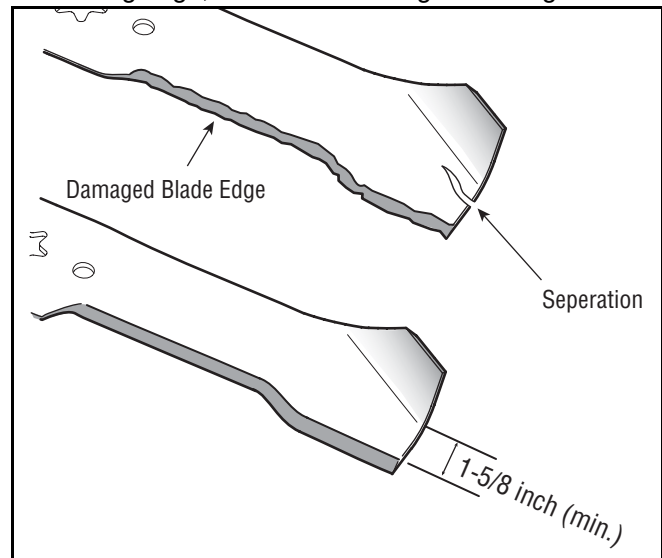

Figure 15

IMPORTANT: If the cutting edge of the blade has already been sharpened, or if any metal separation is present, replace the blades with new ones.

It is important that each cutting blade edge be ground equally to maintain proper blade balance. A poorly balanced blade will cause excessive vibration and may cause damage to the tractor and result in personal injury.

IMPORTANT: When replacing the blade, be sure to install the blade with the side of the blade marked “Bottom” (or with a part number stamped in it) facing the ground when the mower is in the operating position.

IMPORTANT: Use a torque wrench to tighten the blade spindle hex flange nut to between 70 lbs-ft. and 90 lbs-ft.

Battery



California Proposition 65 Warning: Battery posts, terminals, and related accessories contain lead and lead compounds, chemicals known to the State of California to cause cancer and reproductive harm. *Wash hands after handling.*

The battery is sealed and is maintenance-free. Acid levels cannot be checked and fluid can not be added.

- Always keep the battery cables and terminals clean and free of corrosive build-up.
- After cleaning the battery and terminals, apply a light coat of petroleum jelly or grease to both terminals
- Always keep the rubber boot positioned over the positive terminal to prevent shorting.

IMPORTANT: If removing the battery, disconnect the NEGATIVE (Black) wire from its terminal first, followed by the POSITIVE (Red) wire. When re-installing the battery, always connect the POSITIVE (Red) wire to the POSITIVE (+) terminal before connecting the NEGATIVE (Black) wire to the NEGATIVE (-) terminal. Be certain that the wires are connected to the correct terminals; reversing them could change the polarity and cause damage to your engine’s alternator.

Jump Starting



WARNING: Never jump start a damaged or frozen battery. Be certain the vehicles do not touch, and ignitions are off. Do not allow cable clamps to touch.

- Connect positive (+) cable to positive post (+) of your tractor’s discharged battery.
- Connect the other end of the (+) cable to the positive (+) post of the jumper battery.
- Connect the second negative (-) cable to the negative (-) post of the jumper battery.
- Make the final connection on the engine block of the stalled tractor, away from the battery. Attach to a unpainted part to assure a good connection.

IMPORTANT: If the jumper battery is installed on a vehicle (i.e. car, truck), do NOT start the vehicle’s engine when jump starting your tractor.

- Start the tractor (as instructed on page 14).
- Set the tractor’s parking brake before removing the jumper cables, in reverse order of connection.

- Allow the tractor’s engine to run for 15 minutes before shutting it off to allow the alternator time to charge the discharged battery.

Charging

If the unit has not been put into use for an extended period of time, charge the battery with an automotive-type 12-volt charger for a minimum of one hour at a maximum of six amps.



WARNING: Batteries give off an explosive gas while charging. Charge battery in a well ventilated area and keep away from an open flame or pilot light as on a water heater, space heater, furnace, clothes dryer or other gas appliances.

Cutting Deck Removal

To remove the cutting deck, proceed as follows:

- Place the PTO/Blade Engage knob in the disengaged (OFF) position and engage the parking brake.
- Lower the deck by moving the deck lift lever into the bottom notch on the right fender.
- Remove the deck belt from around the tractor’s electric PTO clutch (refer to **Changing the Deck Belt**).
- Looking at the cutting deck from the left side of the tractor, locate the deck support pin on the rear left side of the deck.
- Rotate the pin slightly toward the rear of the tractor and release it.
- Pull the deck support pin outward to release the deck from the deck lift arm. See Figure 16.

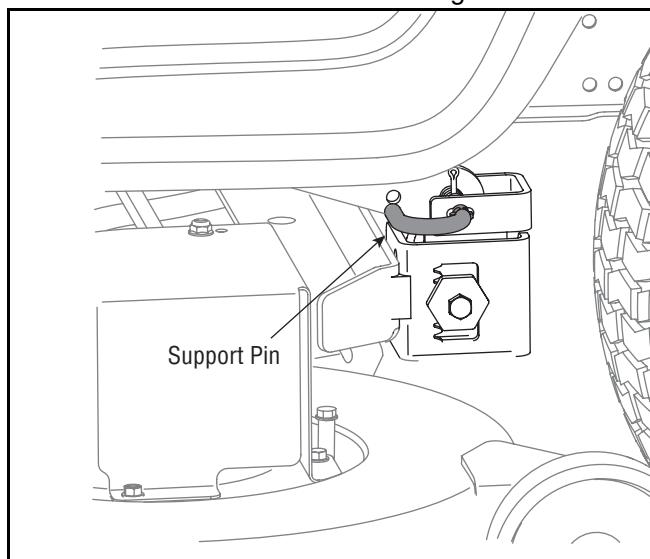

Figure 16

- Repeat the above steps on the tractor’s right side.
- Move the deck lift lever into the top notch to raise the deck lift arms up and out of the way.
- Gently slide the cutting deck toward the front of the tractor allowing the hooks on the deck to release themselves from the deck stabilizer rod.

- Gently slide the cutting deck (from the right side) out from underneath the tractor.

Changing the Deck Belt



WARNING: Be sure to shut the engine off, and remove ignition key to prevent unintended starting before removing the belt.



WARNING: Avoid the possibility of a pinching injury. Do not place your fingers on the idler spring or between the belt and a pulley while removing the belt.

All belts on your tractor are subject to wear and should be replaced if any signs of wear are present.

IMPORTANT: The V-belts found on your tractor are specially designed to engage and disengage safely. A substitute (non-OEM) V-belt can be dangerous by not disengaging completely. For a proper working machine, use factory approved belts.

To change or replace the deck belt on your tractor, proceed as follows:

- Lower the deck by moving the deck lift lever into the bottom notch on the right fender.
- Remove the belt guards by removing the self-tapping screws that fasten them to the deck.
- To ease in removing the belt in later steps, loosen, but do not remove, the bolt which secures the pivoting idler pulley to the idler bracket. See Figure 17.

- Insert a 3/8"-drive ratchet wrench (set to *tighten*) into the square hole found in the idler bracket on the left side of the deck's surface. See Figure 17.

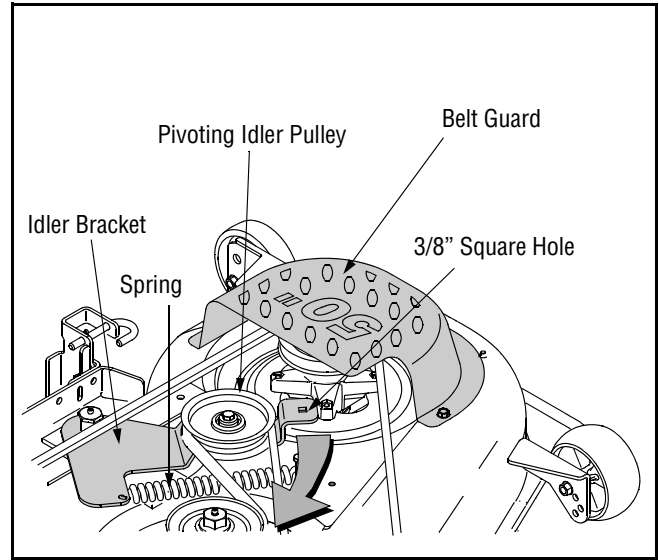

Figure 17

- Grasp the ratchet's handle and pivot it to relieve tension on the belt.
- With belt tension relieved, **carefully remove the belt from around the left-hand spindle pulley.**

IMPORTANT: Carefully allow the ratchet to pivot rearward before removing it from the square hole.

- Remove the deck belt from around all pulleys, including the deck idler pulley and the electric PTO clutch.

NOTE: The idler pulleys may have to be loosened in order to remove the belt from around them.

- Route the new belt as shown below.
- Remount the belt guards removed earlier.

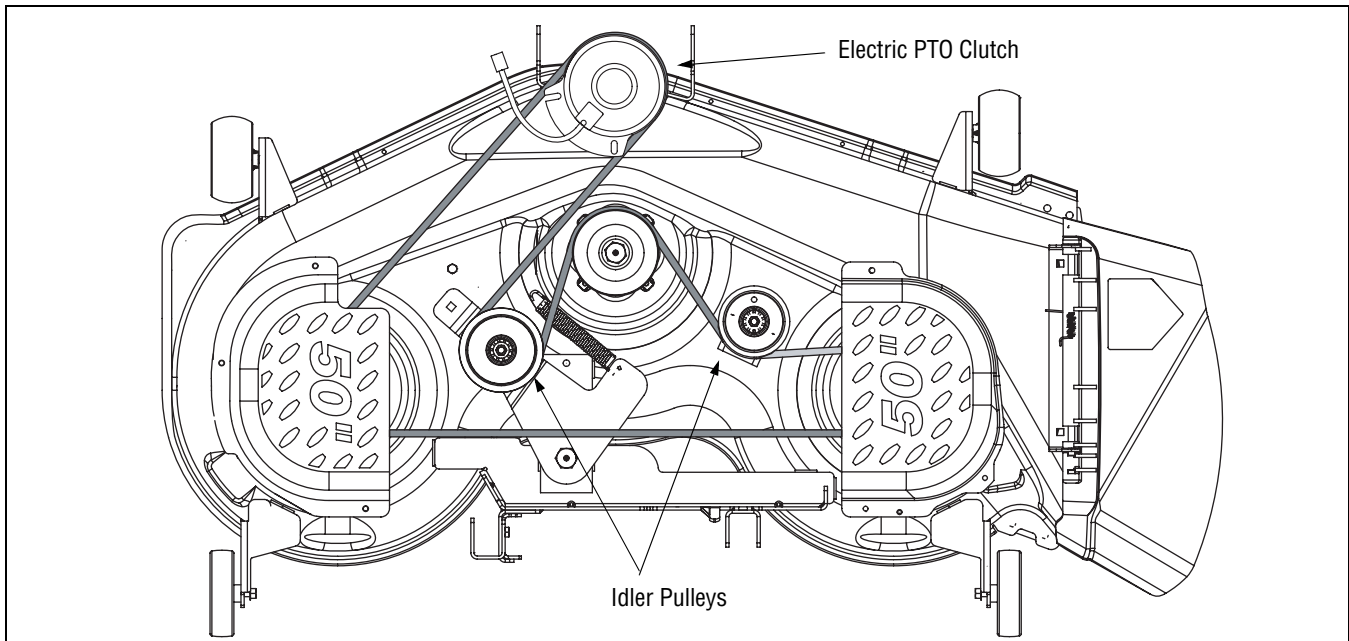

SECTION 9: OFF-SEASON STORAGE

Clean and lubricate the tractor as instructed in **Section 7: MAINTAINING YOUR GARDEN TRACTOR** on page 18 of this manual before storing for an extended period.

Engine

If the engine will be out of service for two months or more, use the following storage procedure:

- Clean the exterior surfaces of the engine.
- Change the oil and filter while the engine is still warm from operation. Refer to **Changing Engine Oil** on page 18.
- The fuel system must be completely emptied, or the gasoline must be treated with a fuel stabilizer such as *STA-BIL*® to prevent deterioration. If you choose to use a stabilizer, follow the manufacturers recommendations, and add the correct amount for the capacity of the fuel system. Fill the fuel tank with clean, fresh gasoline. Run the engine for 2-3 minutes to get stabilized fuel into the carburetor.

To empty the system, run the engine until the tank and system are empty.



WARNING: Drain fuel only into an approved container outdoors, away from an open flame. Allow engine to cool. Extinguish cigarettes, cigars, pipes, and other sources of ignition prior to draining fuel.

- Remove each spark plug. Add one tablespoon of engine oil into each spark plug hole. Install the plugs, but do not reconnect the plug wire. Crank the engine two or three revolutions.
- Store the engine in a clean, dry place.



WARNING: Never store the machine or fuel container indoors where there is an open flame, spark or pilot light such as on water heater, furnace, clothes dryer or other gas appliance.

SECTION 10: ATTACHMENTS & ACCESSORIES

See your dealer or the retailer from which you purchased your tractor for information regarding price and availability.

ATTACHMENTS

OEM-190-964	Rear Tire Chain Set
OEM-190-032	42-inch Two-stage Snow Thrower
OEM-190-833	46-inch Front Dozer Blade
OEM-190-608	Sleeve Hitch, Manual Lift
OEM-190-824	Sleeve Hitch with Electric Lift
OEM-190-192	Triple Bagger Grass Collector
OEM-190-193	Mulch Kit
OEM-190-784	Rear Wheel Weights
OEM-190-679	Bumper Kit
OEM-190-607*	Deluxe Tractor Sunshade
OEM-190-751*	Tractor Snow Cab
OEM-190-184	40" Dethatcher
	<i>*Not compatible with tractors equipped with a Grass Collector.</i>
	SLEEVE HITCH ATTACHMENTS
OEM-190-825	30-inch Hydraulic Tiller †
OEM-190-978	10-inch Mulboard Plow ‡
OEM-190-980	Single-disc Harrow ‡
OEM-190-984	Row Crop Cultivator ‡

† OEM-190-824 is required for use of this attachment. **190-608 can NOT be used in its place.**

‡ Either OEM-190-824 or OEM-190-608 is required for use of this attachment.

SECTION 11: TROUBLESHOOTING

Trouble	Possible Cause(s)	Corrective Action
Engine fails to start	PTO (Blade Engage) knob engaged. Parking brake not engaged. Spark plug wire(s) disconnected. Choke control not in correct starting position. Choke not activated Fuel tank empty, or stale fuel. Blocked fuel line. Faulty spark plug(s). Engine flooded.	Place PTO (Blade Engage) knob in disengaged (OFF) position. Engage parking brake. Connect wire(s) to spark plug. Pull Choke Control into CHOKE position. Pull Choke Control into CHOKE position. Fill tank with clean, fresh (less than 30 days old) gas. Clean fuel line or replace fuel filter. Clean, adjust gap or replace plug. Crank engine with throttle in FAST position.
Engine runs erratic	Unit running with CHOKE activated. Spark plug wire(s) loose. Blocked fuel line or stale fuel. Vent in gas cap plugged. Water or dirt in fuel system. Dirty air cleaner.	Push Choke Control out of CHOKE position. Connect and tighten spark plug wire(s). Clean fuel line; fill tank with clean, fresh (less than 30 days old) gasoline. Replace fuel filter, if so equipped. Clear vent or replace cap if damaged. Drain fuel tank. Refill with clean, fresh (less than 30 days old) gasoline. Replace air cleaner paper element or clean foam pre-cleaner.
Engine overheats	Engine oil level low. Air flow restricted.	Fill crankcase with proper capacity and weight of oil. Clean grass clippings and debris from around the engine's cooling fins and blower housing.
Engine hesitates at high RPM	Spark plug gap too close.	Remove spark plug and reset the gap.
Idles poorly	Spark plug fouled, faulty or gap too wide. Dirty air cleaner.	Replace spark plug. Set plug gap. Replace air cleaner element or clean pre-cleaner.
Excessive vibration	Cutting blade loose or unbalanced. Damaged or bent cutting blade.	Tighten blade and spindle. Balance blade. Replace blade.
Mower will not mulch grass	Engine speed too low. Wet grass. Excessively high grass. Dull blade.	Place throttle in FAST (rabbit) position. Do not mow when grass is wet; wait until later to cut. Mow once at a high cutting height, then mow again at desired height or make a narrower cutting swath. Sharpen or replace blade.
Uneven cut	Deck not balanced properly. Dull blade. Uneven tire pressure.	Perform side-to-side deck adjustment. Sharpen or replace blade. Check tire pressure in all four tires.

SECTION 12: ILLUSTRATED PARTS LIST FOR MODEL GT50

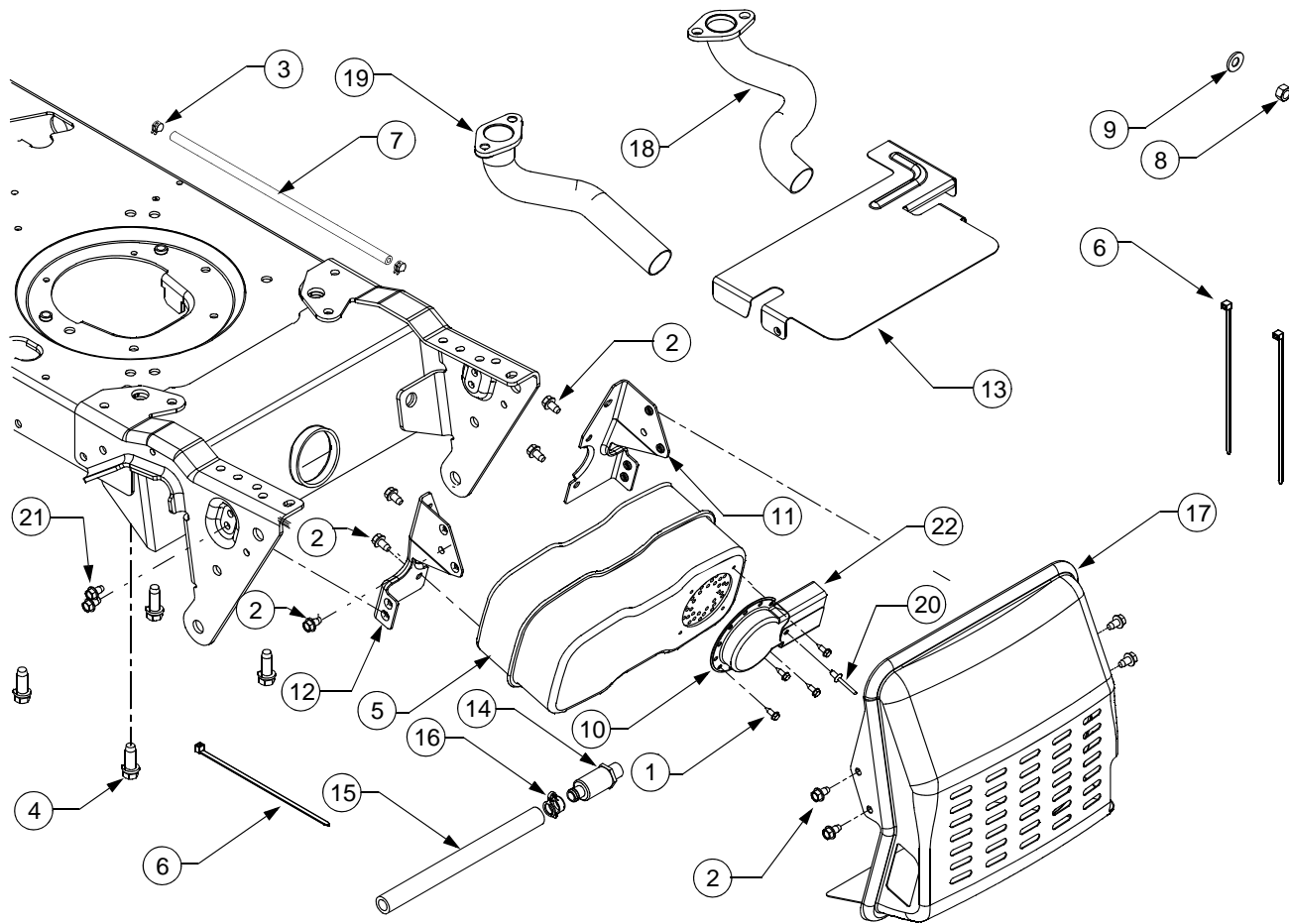

REF. NO.	PART NUMBER	DESCRIPTION
1	710-0227	Screw, #8-18, 0.500
2	710-0599	Screw, Hex, 1/4-20, 0.500
3	726-0205	Clamp
4	710-0654A	Screw, Hex, 3/8-16 x 1.00
5	751-10161	Muffler, Dual Inlet
6	725-0157	Cable, Tie, 3/16 x.05 x 7.4
7	751-10349	Fuel Hose, Low Permeation
8	712-3005	Hex Flange Nut, 3/8-16
9	736-0300	Lock Washer, .406 x.875 x.059
10	751-0564B	Deflector, Muffler
11	783-04573	Muffler Bracket, LH
12	783-04574	Muffler Bracket, RH
13	783-04783	Heat Shield
14	751-3140	Drain, Oil
15	751-3141	Extension Hose, Oil Drain
16	751-3142	Cap, Oil Drain
17	683-04256	Shield, Muffler
18	751-10007	Pipe, Exhaust, LH
19	751-10006	Pipe, Exhaust, RH
20	728-04000	Rivet, Pop., .188 x.325
21	710-0642	Screw, Hex, 1/4-20, 0.750
22	751-10353	Extension, Deflector

Model GT50

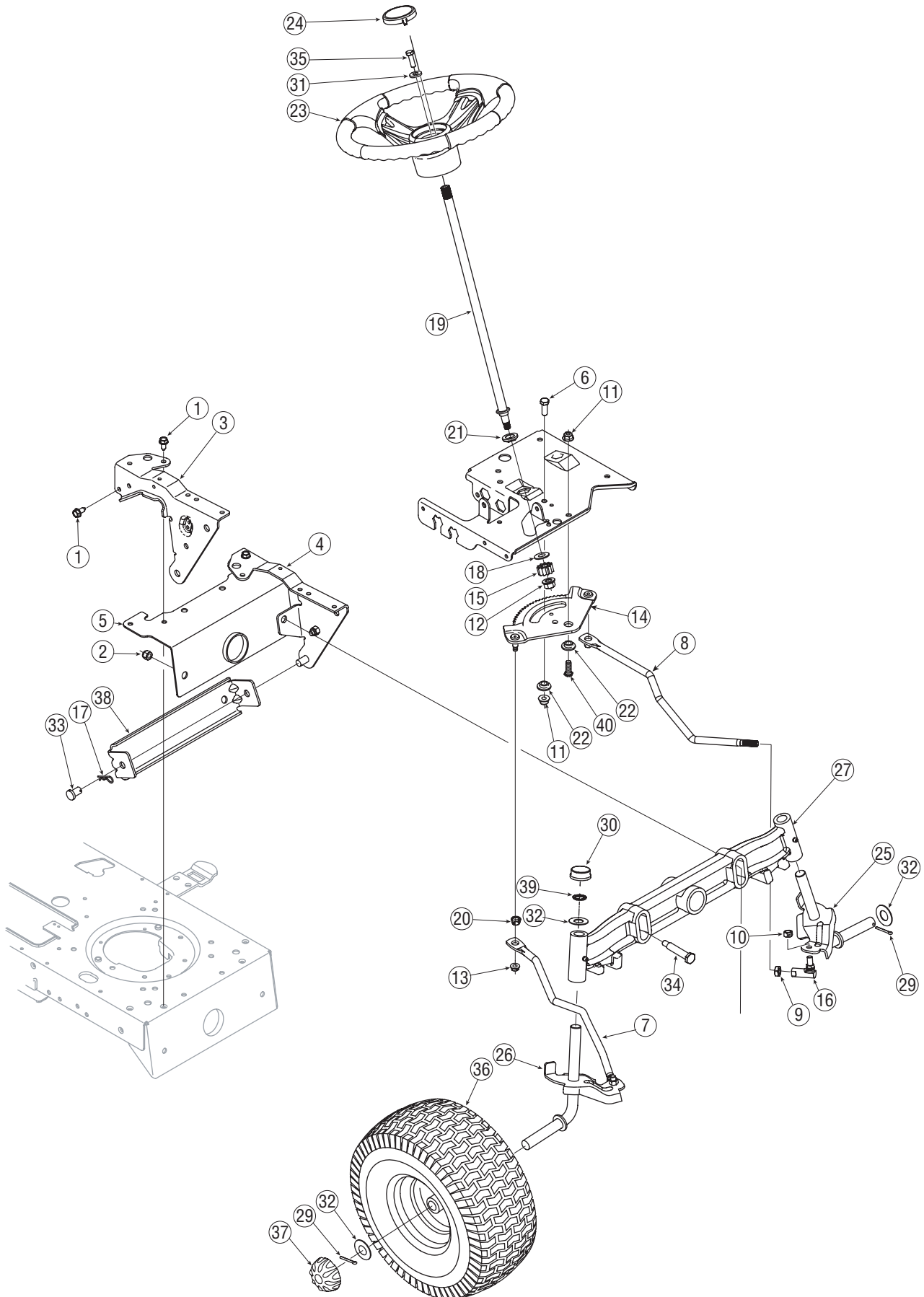

Model GT50

REF. NO.	PART NO.	DESCRIPTION
1	710-1260A	Self-tapping Screw, 5/16-18 x.75
2	712-04065	Nut, Flange Lock, 3/8-16
3	783-0726E	RH Pivot Support Bracket
4	783-0727D	LH Pivot Support Bracket
5	783-0728	Pivot Bar Bracket
6	710-0514	Hex Cap Screw, 3/8-16 x 1
7	711-1408	RH Drag Link
8	711-1409A	LH Drag Link
9	712-0240	Jam Nut, 7/16-20
10	712-0214	Hex Nut, 3/8-24
11	712-0431	Flange Lock Nut, 3/8-16
12	712-0459	Flange Lock Nut, 7/16-20
13	712-3004A	Flange Lock Nut, 5/16-18
14	717-1550E	Steering Gear, 11/90 Ratio
15	717-1554	Steering Pinion Gear
16	723-0448A	Ball Joint, 7/16-20
17	714-04023	Cotter Pin, Internal
18	736-3084	Flat Washer,.51 x 1.12 x.06
19	738-1001A	Steering Shaft,.625 OD x 24.4
20	741-0475	Plastic Bushing,.38 ID
21	741-0656A	Hex Flange Bearing, 5/8
22	738-04154	Shoulder Spacer,.38 x 1.00 x.31
23	631-04008	Steering Wheel, Soft Grip, Three Spoke
24	731-04681	Steering Wheel Cap
25	638-04003A	LH Axle Assembly,.75 Diameter
26	638-04004A	RH Axle Assembly,.75 Diameter
27	719-04177	Cast Iron Pivot Bar
29	714-04039	Cotter Pin
30	731-04693	Hub Cap
31	736-3004	Flat Washer,.406 x.875 x.105
32	736-0316	Flat Washer,.78 x 1.59 x.06
33	711-0332	Pin, Clevis,.50 Dia. x.78 Lg.
34	738-1011A	Shoulder Screw,.5 x 2.2, 3/8-16
35	710-0643	Hex Bolt, 5/16-18 X 1
36	634-04088A	Wheel Assembly Complete, 16 x 7.5 x 8
	634-04082	Rim Only w/ Plastic Bearing
	734-0255	Air Valve (Not Shown)
	734-04148	Tire Only, Square Shoulder
	741-0516A	Flange Bearing
	741-0990A	Flange Bearing w/ Grease Fitting
37	734-2290A	Hub Cap
38	783-0720A	Brkt., Adj., Frt.
39	726-04035	Nut, Push, 3/4 Dia.
40	710-04095	Hex Bolt 3/8-16 x 1.0 Special

Model GT50

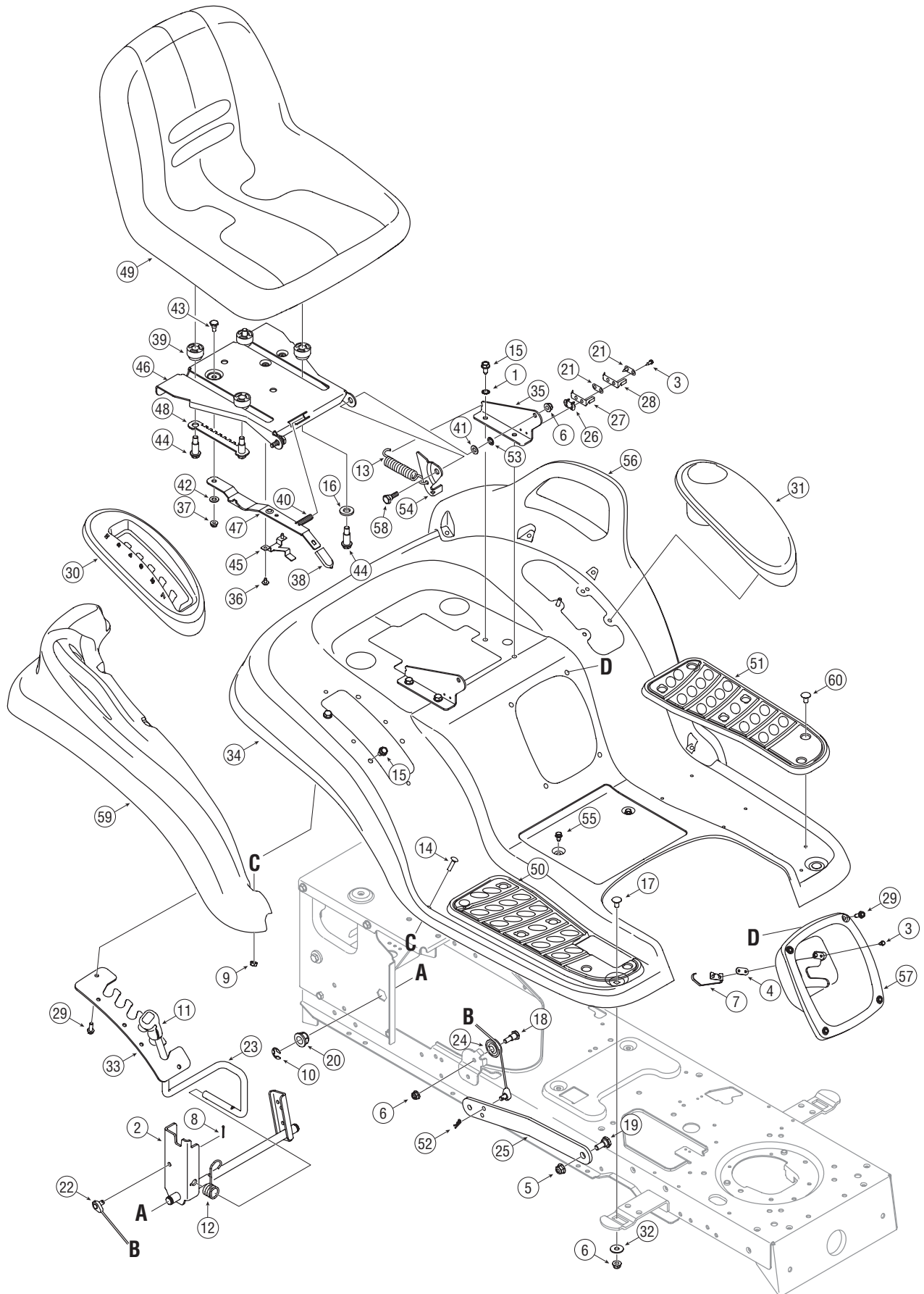

Model GT50

REF. NO.	PART NO.	DESCRIPTION	REF. NO.	PART NO.	DESCRIPTION
1	736-0607	Wash, Lock, 5/16	31	731-1993A	Cover w/ Cup Holder
2	683-04079	Lift Shaft Assembly	32	736-3078	Flat Washer,.349 x 1.0 x.063
3	710-0227	Screw, AB #8-18 x.500	33	783-0677B	Lift Adjustment Bracket
4	726-0320	Plate, Insulator Nut	34	783-04331A	Fender
5	712-04065	Flange Lock Nut, 3/8-16	35	783-1489B	Seat Mounting Bracket
6	712-04063	Flange Lock Nut, 5/16-18	36	710-1268	Screw, #10-16 x.375
7	725-1713	Switch, Spring	37	712-04064	Flange Lock Nut, 1/4-20
8	714-0104	Internal Cotter Pin	38	720-0309A	Seat Adjuster Grip
9	712-0271	Nut, Sems, 1/4-20	39	731-04074	Spacer
10	716-0106A	E-Ring	40	732-0499	Compression Spring,.41 x 1.5
11	720-0311	Handle Grip	41	736-0242	Washer, Bell,.340 x.872 x.060
12	732-0874	Torsion Spring	42	736-0204	Flat Washer,.344 x.62 x.03
13	732-1184	Extension Spring,.84 x 4.6	43	738-0137A	Shoulder Screw,.340 x.285,1/4-20
14	710-0932	Screw, Carriage, 1/4-20 x 1.00	44	738-0966A	Shoulder Bolt,.50 x.925, 3/8-16
15	710-0604A	Screw, TT, 5/16-18 x.625	45	783-0611	Seat Stop
16	736-3019	Flat Washer,.31 x 1.062 x.134	46	783-0738C	Seat Pivot Bracket
17	710-0451	Bolt, Carriage, 5/16-18 x.750	47	783-0739A	Seat Adjustment Lever
18	738-0138A	Hex Cap Screw, 5/16-18 x.62	48	783-0753	Seat Adjustment Selector
19	738-0380	Shoulder Screw, 3/8-16	49	757-04010	High Back Seat, Black
20	741-0225	Hex Flange Bearing	50	735-0656	RH Foot Pad
21	726-0279	Plate, Insulator	51	735-0657	LH Foot Pad
22	746-0968	Lift Cable, 16.16	52	714-0111	Cotter Pin
23	747-04155	Lift Handle	53	726-0201	Nut, Spd.,.3125 ID
24	756-1154	Roller Pulley	54	783-0209D	Seat Lift Bracket
25	783-0678A	Arm Lift	55	710-0599	Screw, TT, 1/4-20 x 0.5
26	726-0278	Plate, Insulator Boss	56	731-2619	LH Fender Flare
27	725-1439	Switch, Inner, Seat Spring	57	731-2480A	Shift Lever Cover
28	725-1303	Switch, Outer, Seat Spring	58	738-0296	Shoulder Screw,.437 x.286
29	710-0895	Self-tapping Screw, 1/4-15 x.75	59	731-2618	RH Fender Flare
30	731-1990	Lift Lever Cover	60	726-3046	Foot Pad Clips

Model GT50

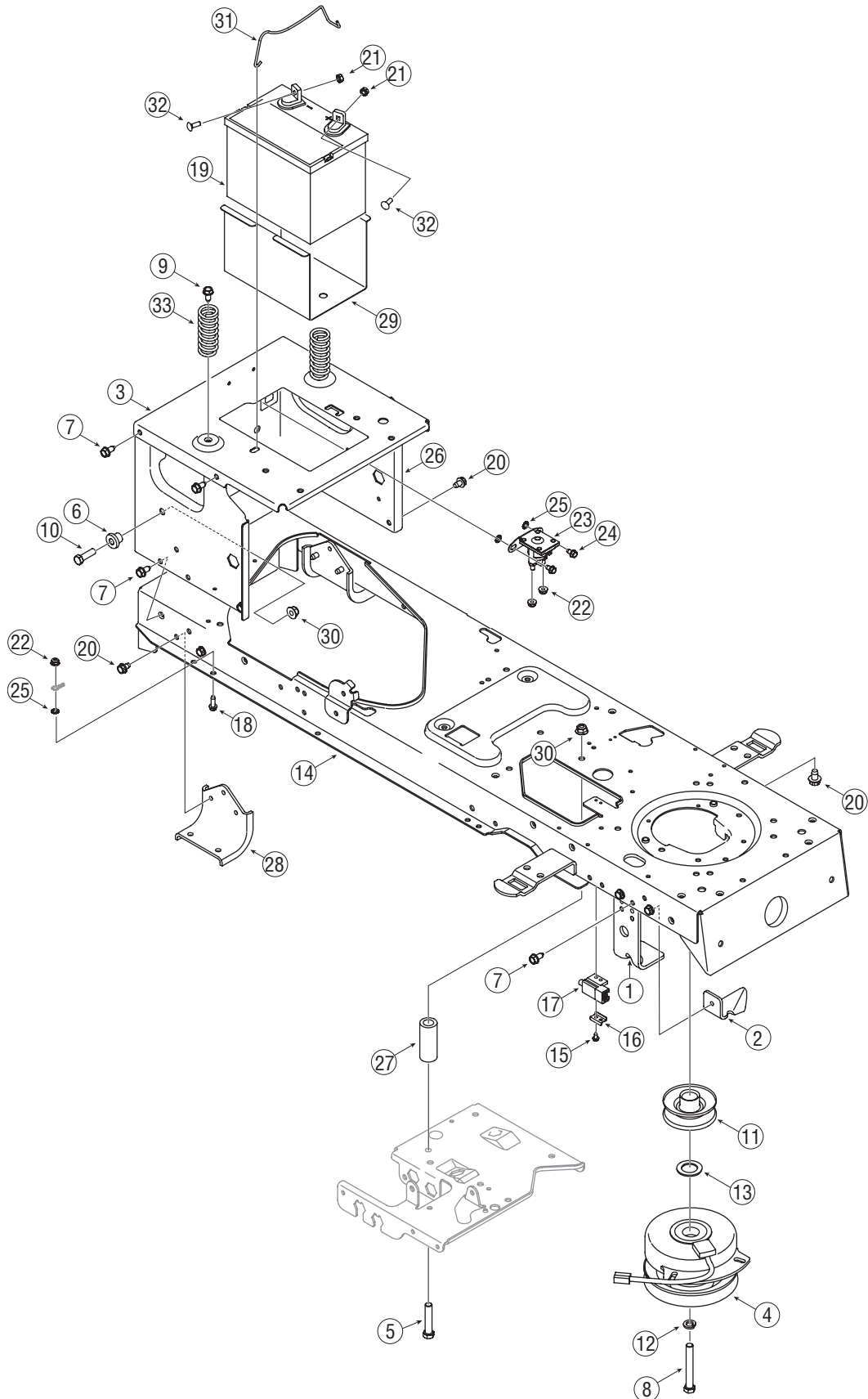

Model GT50

Ref.No.	Part No.	Description
1.	783-04467	Up Stop Deck Bracket
2.	783-04419B	Clutch Bracket
3.	783-04329A	Seat Frame Bracket
4.	717-04174	Electric Clutch
5.	710-3011	Hex Screw, 3/8-16 x 2.25
6.	738-04058	Spacer, Shldr,.38 x 1.0 x.70
7.	710-0726	AB Screw, 5/16-12 x.75
8.	710-04379A	Hex Screw, 7/16-20 x 3.50
9.	710-1260A	Screw, LD, 5/16-18 x.750
10.	710-3005	Screw, 3/8-16 x 1.25
11.	756-0639A	Engine Pulley
12.	736-0171	Lock Washer
13.	736-0277	Flat Washer, 1.031 x 1.620 x.095
14.	683-04173A	Lower Frame Assembly
15.	710-0224	AB Screw #10-16 x 0.5
16.	17962	Switch Plate
17.	725-04039	Switch
18.	710-0642	TT Screw 1/4-20 x 0.75
19.	725-1750A	12 V Battery, 235 CCA
20.	710-0607	TT Screw 5/16-18 x 0.5
21.	712-0271	Hex Sems Nut, 1/4-20
22.	712-04064	Flange Lock Nut, 1/4-20
23.	725-1426A	Solenoid, 12-Volt, 100 Amp
24.	710-0599	Self Tapping Screw, 1/4-20 x.5
25.	736-0222	Lock Washer, 1/4
26.	783-04811A	Upper Frame
27.	748-0415B	Spacer
28.	783-0693	Axle Bracket
29.	783-0349	Battery Tray
30.	712-04065	Flange Lock Nut, 3/8-16
31.	747-04121A	Battery Hold Rod
32.	710-0703	Screw, Carriage, 1/4-20 x.75
33.	732-04035	Compression Spring, 1.28 x 3.125

Model GT50

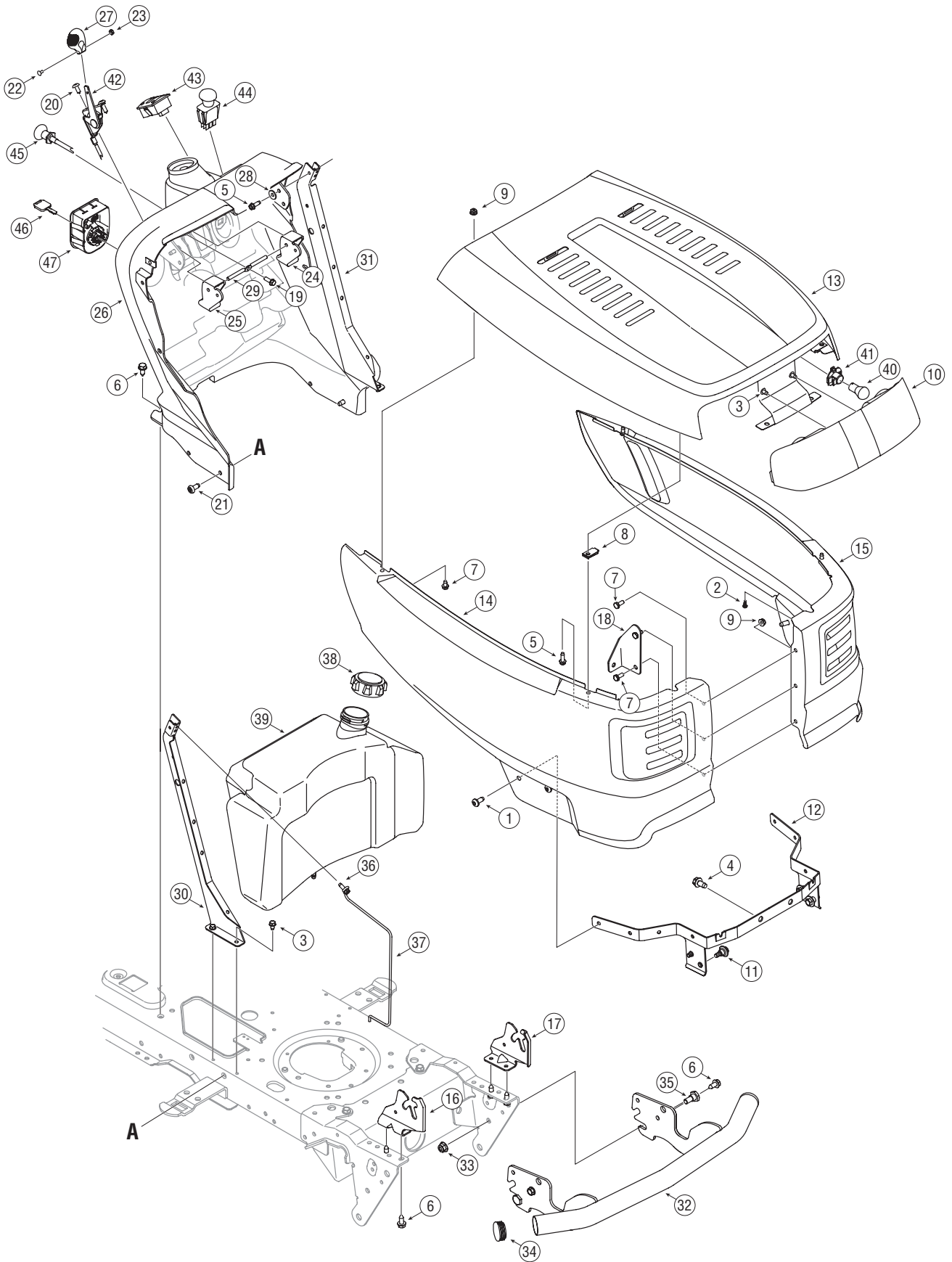

Model GT50

REF. NO.	PART NO.	DESCRIPTION	REF. NO.	PART NO.	DESCRIPTION
1	710-04593	Screw TT, 5/16-18 x.375	27	731-1857	Control Knob
2	710-04599	Screw #8-18 x.500	28	736-0270	Bell Washer.265 x.75 x.062
3	710-0599	Screw TT, 1/4-20 x.500	29	747-1196	Lever Rod
4	710-0623	Screw TT, 3/8-16 x.750	30	783-04285D	RH Plate Dash Support
5	710-0642	Screw TT, 1/4-20 x.750	31	783-04323D	LH Plate Dash Support
6	710-0726	Screw AB, 5/16-12 x.750	32	683-04219	Bumper
7	710-0751	HH Cap Screw 1/4-20 x.620	33	712-04065	Flange Lock Nut 3/8-16
8	712-0292	Clip Nut 1/4-20	34	731-05598	Bumper Cap
9	712-04064	Flange Lock Nut 1/4-20	35	738-0143	Shoulder Screw.498 x.340 x 3/8-16
10	731-05357	Lens	36	710-0642	Screw TT, 1/4-20 x.75
11	738-04091	Shoulder Screw.43x.29:TT:5/16-18	37	747-04161	Tank Support Rod
12	783-04606A	Pivot Bracket	38	751-0603	Fuel Cap
13	783-04827	Hood	39	751-10283	Fuel Tank, 3 Gal.
14	783-04828	RH Side Panel	40	725-0963	Miniature Lamp, 12V
15	783-04829	LH Side Panel	41	725-1649	Socket, Lamp
16	783-04840	RH Hood Pivot Bracket	42	746-1086	Throttle Cable 39-inch
17	783-04841	LH Hood Pivot Bracket	43	725-04036B	Systems Indicator Monitor w/Hour Meter
18	783-05116	Support Hood Bracket	44	725-04174	Electric PTO Switch
19	710-0895	Screw HL, 1/4-15 x.750	45	746-04132	Choke Control 37.5" x 2
20	710-1017	Screw AB, 1/4-14 x.625	46	725-1744	Ignition Key
21	710-1611B	Screw TT, 5/16-18 x.750		725-1745	Ignition Key w/ Plastic Cover
22	710-3217	Screw #8-32 x.375	47	725-04227A	Ignition Switch Module
23	712-0142	Hex Nut #8-32	—	629-04083	Headlight Wire Harness <i>(not pictured)</i>
24	731-04728	Brake Dash Lever	—	725-04336	Tractor Wire Harness <i>(not pictured)</i>
25	731-04729	Cruise Dash Lever	—	725-0157	Cable Tie <i>(not pictured)</i>
26	731-05005B	Dash Panel			

Model GT50

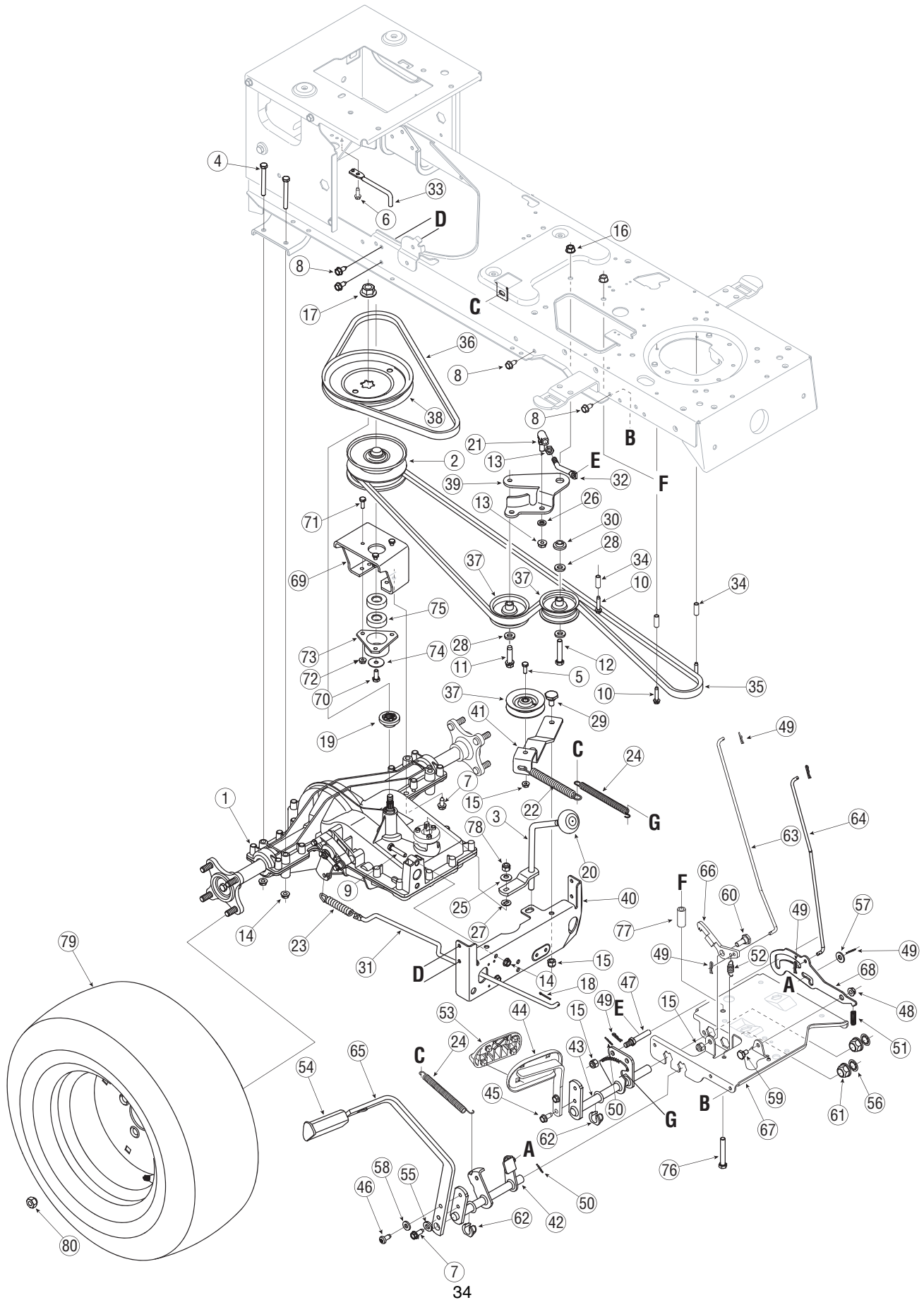

Model GT50

REF. NO.	PART NUMBER	DESCRIPTION	REF. NO.	PART NUMBER	DESCRIPTION
1	753-05002	Transmission Assembly, 2-Speed	42	647-0031B	Control Assembly, Brake
2	656-04015	Pulley Assembly, Variable Speed	43	647-0032A	Control Assembly, Speed
3	647-04023	Rod Assembly, Shift, 2-Speed	44	683-0266	Pedal Assembly, Control
4	710-0176	Screw, 5/16-18, 2.75, Gr5	45	710-1260A	Screw, 5/16-18, 0.750
5	710-0347	Screw, 3/8-16, 1.75, Gr5	46	710-1611B	Screw, 5/16-18, 0.750
6	710-0642	Screw, 1/4-20, 0.750	47	711-04159B	Pin, 3/8-16 x 2.68
7	710-0650	Screw, 5/16-18, 0.875	48	712-3004A	Nut, Flange Lock, 5/16-18, Gr5
8	710-0726	Screw, 5/16-12, 0.750	49	714-0104	Pin, Cotter, .072 Dia. x 1.13
9	710-0805	Screw, 5/16-18, 1.50, Gr5	50	714-0111	Pin, Cotter, 3/32, 1.0
10	710-0809	Screw, 1/4-20, 1.250	51	732-0335	Spring, Compression, .405 x 1.17
11	710-1007	Screw, Sems, 3/8-16, 1.500	52	732-0955	Spring, Extension, .50 OD x 1.41
12	710-3011	Screw, 3/8-16, 2.25, Gr5	53	735-0662	Pad, Drive Control
13	712-0241	Nut, Hex, 3/8-24, Gr5	54	735-3049	Pad, Brake
14	712-04063	Nut, Flange Lock, 5/16-18, GrF, Nylon	55	736-0119	Washer, Lock, 5/16, Regular Duty
15	712-04065	Nut, Flange Lock, 3/8-16, GrF, Nylon	56	736-0187	Washer, Flat, .64 x 1.24 x .06
16	712-0431	Nut, Flange Lock, 3/8-16, GrF,	57	736-0262	Washer, Flat, .385 x .870 x .092
17	712-0702	Nut, Flange, 7/16-20, Gr2	58	736-3008	Washer, Flat, .344 x .750 x .120
18	714-0507	Pin, Cotter, 3/32 x .750	59	738-0155	Shoulder Screw, .437 Dia x .162
19	718-0771A	Hub, Pulley, 1/2 Spline	60	738-0380	Screw, Shoulder, .50 x .27, 3/8-16
20	720-04028	Knob, Shift	61	741-0225	Bearing, Hex Flange
21	723-3018	Ball, Joint	62	741-3065B	Bearing, Hex Flange, .628 ID, Split
22	732-0478	Extension, Spring 6.12	63	747-04093	Control Rod, Brake Lock
23	732-0716C	Spring, Extension, .59 OD x 4.00	64	747-04096	Control Rod, Cruise
24	732-0963	Spring, Extension, .50 Dia x 6.37	65	747-04521	Pedal, Brake
25	736-0105	Washer, Bell, .375 x .870 x .063	66	748-04039B	Latch, Cruise
26	736-0169	Washer, Lock, 3/8, Regular Duty	67	783-04612	Bracket, Steering Support
27	736-0642	Washer, Flat, .44x.75x.06, Ht Spcl	68	783-0732A	Bracket, Lockout
28	736-3010	Washer, Flat, .407x.812x.135, Ht	69	618-04200	Pulley Bracket
29	738-0322	Screw, Shoulder, .625 Dia x .217	70	710-0627	Screw, 5/16-24, .75
30	738-0372B	Spacer, Shoulder, 1.00 x .38 x .38	71	710-3015	Screw, 1/4-20, .75
31	747-04136	Brake Rod	72	712-3027	Nut, Flange Lock, 1/4-20
32	747-1127	Adjustment Rod, Idlr, 3/8	73	718-04012	Bearing Cup
33	747-1185A	Rod, Belt Guard	74	736-0362	Washer, Flat, .330 x 1.25 x .06
34	750-0566A	Spacer, .260 x .372 x 1.030	75	741-0600	Ball Bearing
35	754-0467	Belt, V-Type	76	710-3011	Screw, 3/8-16, 2.25
36	754-0468	Belt, V-Type	77	748-0415B	Spacer, .385 x .635 x 1.54
37	756-04224	Pulley, Flat Idler, 2.75	78	712-0181	Nut, Jam Lock, 3/6-16
38	756-0665	Pulley, V-Type, 8.50	79	634-0202A	Wheel Assembly, 23 x 10.5 x 12
39	783-04442	Idler Bracket, Center Double		734-04147	Tire, 23 x 10.5 x 12
40	783-0667B	Torque Bracket, Transmission,		634-3178	Rim Assembly
41	783-0669	Bracket, Idler	80	712-3050	Lug Nut, 7/16-14

Model GT50

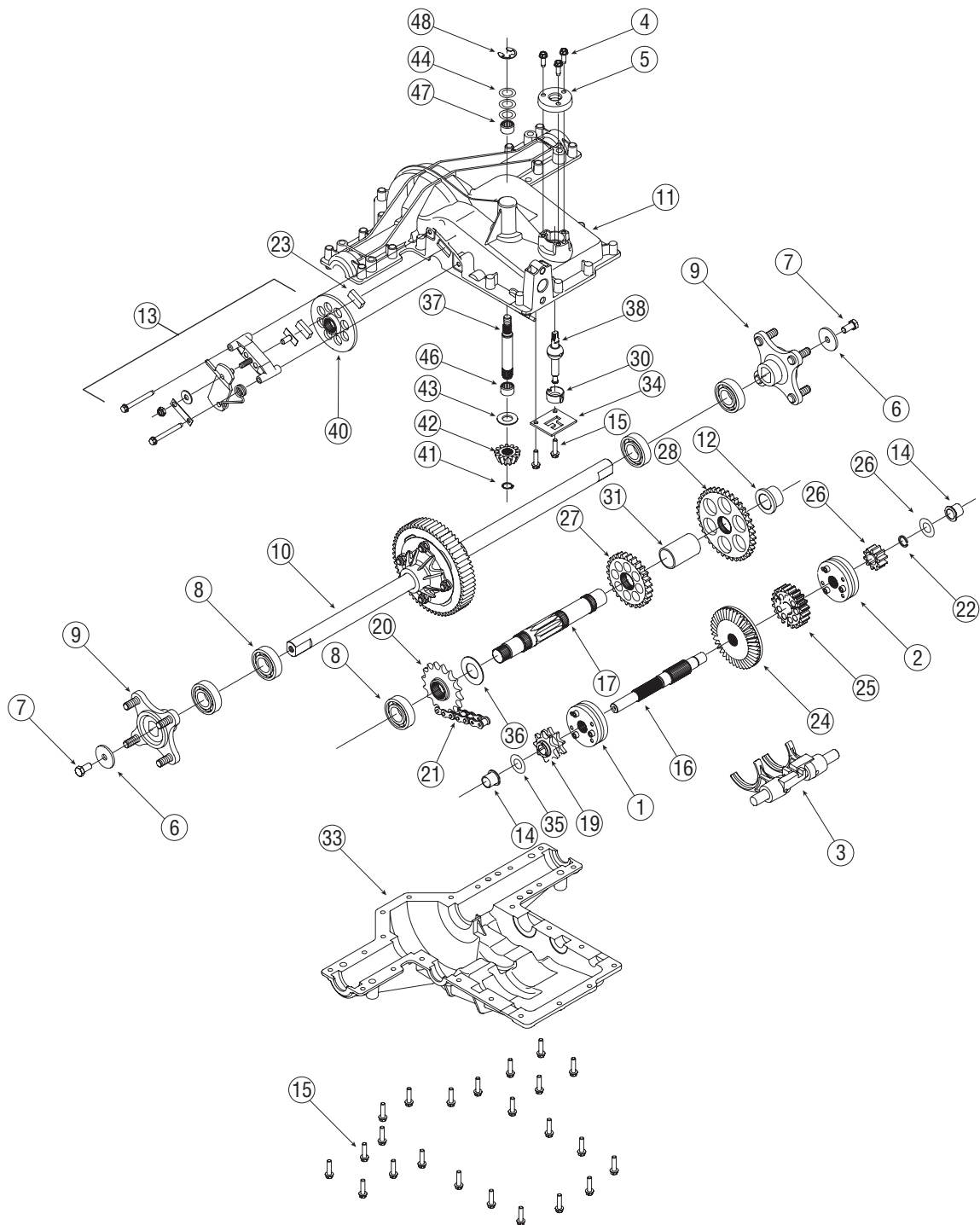

Model GT50

REF. NO.	PART NO.	DESCRIPTION
1	618-0225	Reverse Collar Assembly
2	618-0226	Hi-Lo Collar Assembly
3	918-04156	Shift Fork Assembly
4	910-0642	Self-tapping Screw, 1/4-20 x.75
5	718-04053	Shift Cover
6	936-0227	Flat Washer
7	710-3119	Lock bolt 3/8-16 x 0.75
8	741-0681	Ball Bearing
9	918-04317	Wheel Hub Assembly
10	918-04142	Differential Axle Assembly
11	619-04081	Upper Housing
12	941-0476	Flanged Bearing
13	961-0012	Brake Assembly
14	741-04085	Flanged Bearing
15	710-0788	Screw 1/4-20 x 1.0
16	711-1051A	Drive Shaft
17	711-1216	Output Shaft
19	913-0446	9-tooth Sprocket
20	913-0447	16-tooth Sprocket
21	913-0448	22-link Chain,.625
22	916-0131	External Snap Ring
23	917-0678	Brake Pad
24	917-1438A	41-tooth Bevel Gear
25	917-1439A	20-tooth Spur Gear
26	717-1440	10-tooth Spur Gear
27	717-04109	27-tooth Spur Gear
28	717-04110	37-tooth Spur Gear
30	718-0504	Shifter Insert
31	718-0505	Shifter Cover
33	753-05002	Lower Housing
34	718-0540	Lockout Plate
35	936-0337	Flat Washer, 5/8 x 1.0
36	736-3046A	Flat Washer, 1.01 x 1.86 x.060
37	711-1235	Input Shaft
38	747-1140	Shift Lever
40	761-0215	Disc Brake
41	916-0114	Retaining Ring,.56
42	717-1463A	13-tooth Bevel Gear
43	936-0335	Flat Washer
44	936-0336	Flat Washer, 5/8 x 1.0 x.030*
	936-0337	Flat Washer, 5/8 x 1.0 x.040*
	936-0349	Flat Washer,5/8 x 1.0 x.020*
46	941-0335	Needle Bearing
47	741-0696	Needle Bearing
48	916-0231	E-ring,.75

Model GT50

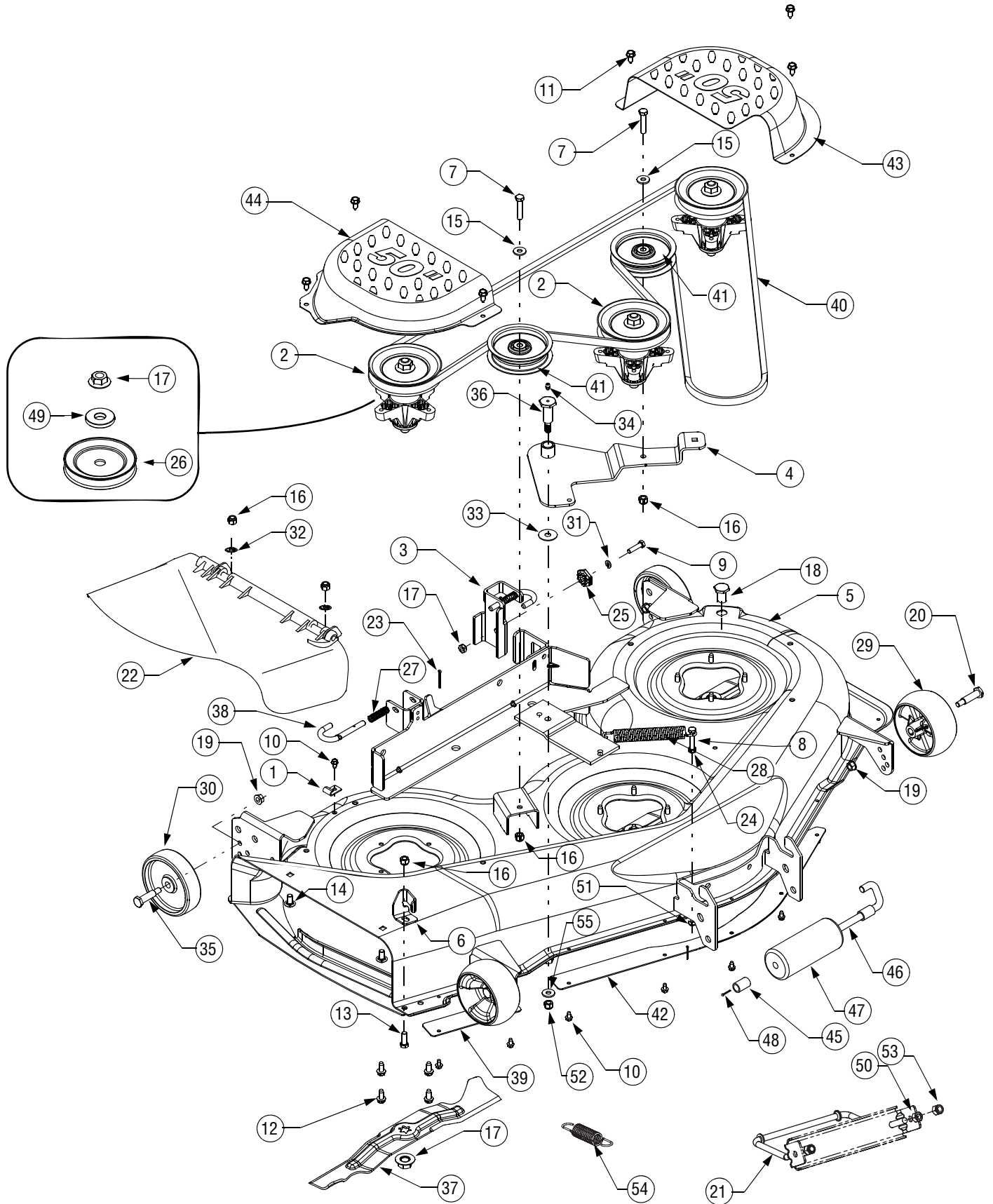

Model GT50

REF. NO.	PART NUMBER	DESCRIPTION
1	16606	Hook, Retainer
2	618-04126	Spindle Assembly
3	683-0254B	Hanger Bracket Assembly
4	683-04239	Idler Bracket
5	683-04109B	Deck Assembly, 50-inch
6	703-3279	Deflector Chute Stop
7	710-0347	Screw, 3/8-16, 1.75
8	710-3103	Screw, 5/16-18 x 2.00
9	710-0528	Screw, 5/16-18, 1.25, Gr5
10	710-0599	Screw, 1/4-20 x 0.5
11	710-0607	Screw, 5/16-18 x.500
12	710-1260A	Screw, 5/16-18 x.75
13	710-04095	Screw, 3/8-16 x 1.0
14	710-3178	Screw, Carriage, 3/8-16 x.75
15	736-0300	Washer, Flat,.406 x.875 x.059
16	712-04065	Nut, Nylon Lock, 3/8-16
17	712-0417A	Nut, Hex, Flange, 5/8-18
18	738-04146	Plug, Screw, M16 x 1.5
19	712-0431	Nut, Flange Lock, 3/8-16
20	738-3056	Shld, Screw, 1/2 Dia. x 2.50 Lg.
21	747-1324	Rod, Deck, Front
22	631-04070A	Chute Assembly, Side Discharge
23	714-0470	Pin, Cotter, 1/8 x 1.25
24	712-3010	Nut, Hex, 5/16-18
25	717-04074	Deck Adjustment Gear
26	756-1171	Pulley, 5.39"
27	732-0306A	Spring, Compression,.531 x 1.75
28	732-0459B	Spring, Extension,.94 x 6.74
29	734-04155	Deck Wheel, 5.0
30	734-0973	Deck Wheel, 5.0
31	736-0119	Washer, Lock, 5/16
32	712-0229	Push Nut, 3/8
33	736-0406	Washer, Flat,.442 x 1.38 x.060
34	737-3000	Fitting, Lube, 3/16
35	738-0373	Shoulder Screw
36	738-3005A	Screw, Shoulder,.68 x 1.59
37	742-04053A	Blade, 17.90
38	747-1116	Rod, Deck Release.375 Dia.
39	783-04415	Deck Skirt, RH
40	754-04107	Belt, V-Type, Aramid
41	756-04129	Pulley, Idler, 3.5"
42	783-04414A	Deck Skirt, Center
43	783-04399	LH Belt Cover
44	783-04400	RH Belt Cover
45	750-0151	Spacer, 1.1"
46	711-1737	Roller Pin
47	731-3005	Roller
48	714-0111	Pin, Cotter, 3/32 x 1.00
49	736-0315	Wash, Flat,.760 x 1.50 x.120
50	712-0206	Nut, Hex, 1/2-13
51	712-04063	Nut, Flange Lock, 5/16-18
52	712-3019	Nut, Hex, 7/16-14
53	712-3083	Nut, Hex Lock, 1/2-13
54	732-0934	Spring, Extension, 1.15 Dia. x 5.99
55	736-0407	Wash, Bell,.45 x 1.00 x.062

NOTES

NOTES

NOTES

**CALIFORNIA EMISSION CONTROL WARRANTY STATEMENT
YOUR WARRANTY RIGHTS AND OBLIGATIONS**

The California Air Resources Board and MTD Consumer Group Inc are pleased to explain the evaporative emission control system warranty on your 2006 lawn mower. In California, new lawn mower must be designed, built and equipped to meet the State's stringent anti-smog standards. MTD Consumer Group Inc must warrant the EECS on your lawn mower for the period of time listed below provided there has been no abuse, neglect or improper maintenance of your lawn mower.

Your EECS may include parts such as the carburetor, fuel-injection system, the ignition system, catalytic converter, fuel tanks, fuel lines, fuel caps, valves, canisters, filters, vapor hoses, clamps, connectors, and other associated emission-related components.

Where a warrantable condition exists, MTD Consumer Group Inc will repair your lawn mower at no cost to you including diagnosis, parts and labor.

MANUFACTURER'S WARRANTY COVERAGE:

This evaporative emission control system is warranted for two years. If any evaporative emission-related part on your equipment is defective, the part will be repaired or replaced by MTD Consumer Group Inc.

OWNER'S WARRANTY RESPONSIBILITIES:

As the lawn mower owner, you are responsible for performance of the required maintenance listed in your owner's manual. MTD Consumer Group Inc recommends that you retain all receipts covering maintenance on your lawn mower, but MTD Consumer Group Inc cannot deny warranty solely for the lack of receipts.

As the lawn mower owner, you should however be aware that MTD Consumer Group Inc may deny you warranty coverage if your lawn mower or a part has failed due to abuse, neglect, or improper maintenance or unapproved modifications.

You are responsible for presenting your lawn mower to MTD Consumer Group Inc's distribution center or service center as soon as the problem exists. The warranty repairs should be completed in a reasonable amount of time, not to exceed 30 days. If you have a question regarding your warranty coverage, you should contact the MTD Consumer Group Inc Service Department at 1-800-800-7310.

GENERAL EMISSIONS WARRANTY COVERAGE:

MTD Consumer Group Inc warrants to the ultimate purchaser and each subsequent purchaser that the lawn mower is: Designed, built and equipped so as to conform with all applicable regulations; and free from defects in materials and workmanship that cause the failure of a warranted part to be identical in all material respects to that part as described in MTD Consumer Group Inc's application for certification.

The warranty period begins on the date the lawn mower is delivered to an ultimate purchaser or first placed into service. The warranty period is two years.

Subject to certain conditions and exclusions as stated below, the warranty on emission-related parts is as follows:

1. Any warranted part that is not scheduled for replacement as required maintenance in the written instructions supplied, is warranted for the warranty period stated above. If the part fails during the period of warranty coverage, the part will be repaired or replaced by MTD Consumer Group Inc according to subsection (4) below. Any such part repaired or replaced under warranty will be warranted for the remainder of the period.
2. Any warranted part that is scheduled only for regular inspection in the written instructions supplied is warranted for the warranty period stated above. Any such part repaired or replaced under warranty will be warranted for the remaining warranty period.
3. Any warranted part that is scheduled for replacement as required maintenance in the written instructions supplied is warranted for the period of time before the first scheduled replacement date for that part. If the part fails before the first scheduled replacement, the part will be repaired or replaced by MTD Consumer Group Inc according to subsection (4) below. Any such part repaired or replaced under warranty will be warranted for the remainder of the period prior to the first scheduled replacement point for the part.
4. Repair or replacement of any warranted part under the warranty provisions herein must be performed at a warranty station at no charge to the owner.
5. Notwithstanding the provisions herein, warranty services or repairs will be provided at all of our distribution centers that are franchised to service the subject engines or equipment.
6. The lawn mower owner will not be charged for diagnostic labor that is directly associated with diagnosis of a defective, emission-related warranted part, provided that such diagnostic work is performed at a warranty station.
7. MTD Consumer Group Inc is liable for damages to other engine or equipment components proximately caused by a failure under warranty of any warranted part.
8. Throughout the lawn mower warranty period stated above, MTD Consumer Group Inc will maintain a supply of warranted parts sufficient to meet the expected demand for such parts.
9. Any replacement part may be used in the performance of any warranty maintenance or repairs and must be provided without charge to the owner. Such use will not reduce the warranty obligations of MTD Consumer Group Inc.
10. Add-on or modified parts that are not exempted by the Air Resources Board may not be used. The use of any non-exempted add-on or modified parts by the ultimate purchaser will be grounds for disallowing a warranty claims. MTD Consumer Group Inc will not be liable to warrant failures of warranted parts caused by the use of a non-exempted add-on or modified part.

WARRANTED PARTS:

The repair or replacement of any warranted part otherwise eligible for warranty coverage may be excluded from such warranty coverage if MTD Consumer Group Inc demonstrates that the lawn mower has been abused, neglected, or improperly maintained, and that such abuse, neglect, or improper maintenance was the direct cause of the need for repair or replacement of the part. That notwithstanding, any adjustment of a component that has a factory installed, and properly operating, adjustment limiting device is still eligible for warranty coverage. The following emission warranty parts list are covered: Fuel Line, Fuel Line Clamps

MANUFACTURER'S LIMITED WARRANTY FOR:



The limited warranty set forth below is given by MTD LLC with respect to new merchandise purchased and used in the United States, its possessions and territories.

"MTD" warrants this product against defects in material and workmanship for a period of two (2) years commencing on the date of original purchase and will, at its option, repair or replace, free of charge, any part found to be defective in materials or workmanship. This limited warranty shall only apply if this product has been operated and maintained in accordance with the Operator's Manual furnished with the product, and has not been subject to misuse, abuse, commercial use, neglect, accident, improper maintenance, alteration, vandalism, theft, fire, water, or damage because of other peril or natural disaster. Damage resulting from the installation or use of any part, accessory or attachment not approved by MTD for use with the product(s) covered by this manual will void your warranty as to any resulting damage.

Normal wear parts are warranted to be free from defects in material and workmanship for a period of thirty (30) days from the date of purchase. Normal wear parts include, but are not limited to items such as: batteries, belts, blades, blade adapters, grass bags, rider deck wheels, seats, snow thrower skid shoes, shave plates, auger spiral rubber and tires.

HOW TO OBTAIN SERVICE: Warranty service is available, WITH PROOF OF PURCHASE, through your local authorized service dealer. To locate the dealer in your area, check your Yellow Pages, or contact MTD LLC at P.O. Box 361131, Cleveland, Ohio 44136-0019, or call 1-866-840-6483 or log on to our Web site at www.troybilt.com.

This limited warranty does not provide coverage in the following cases:

- a. The engine or component parts thereof. These items may carry a separate manufacturer's warranty. Refer to applicable manufacturer's warranty for terms and conditions.
- b. Log splitter pumps, valves, and cylinders have a separate one year warranty.
- c. Routine maintenance items such as lubricants, filters, blade sharpening, tune-ups, brake adjustments, clutch adjustments, deck adjustments, and normal deterioration of the exterior finish due to use or exposure.
- d. Service completed by someone other than an authorized service dealer.

- e. MTD does not extend any warranty for products sold or exported outside of the United States, its possessions and territories, except those sold through MTD's authorized channels of export distribution.
- f. Replacement parts that are not genuine MTD parts.
- g. Transportation charges and service calls.

No implied warranty, including any implied warranty of merchantability of fitness for a particular purpose, applies after the applicable period of express written warranty above as to the parts as identified. No other express warranty, whether written or oral, except as mentioned above, given by any person or entity, including a dealer or retailer, with respect to any product, shall bind MTD. During the period of the warranty, the exclusive remedy is repair or replacement of the product as set forth above.

The provisions as set forth in this warranty provide the sole and exclusive remedy arising from the sale. MTD shall not be liable for incidental or consequential loss or damage including, without limitation, expenses incurred for substitute or replacement lawn care services or for rental expenses to temporarily replace a warranted product.

Some states do not allow the exclusion or limitation of incidental or consequential damages, or limitations on how long an implied warranty lasts, so the above exclusions or limitations may not apply to you.

In no event shall recovery of any kind be greater than the amount of the purchase price of the product sold. **Alteration of safety features of the product shall void this warranty.** You assume the risk and liability for loss, damage, or injury to you and your property and/or to others and their property arising out of the misuse or inability to use the product.

This limited warranty shall not extend to anyone other than the original purchaser or to the person for whom it was purchased as a gift.

HOW STATE LAW RELATES TO THIS WARRANTY: This limited warranty gives you specific legal rights, and you may also have other rights which vary from state to state.

IMPORTANT: Owner must present Original Proof of Purchase to obtain warranty coverage.

MTD LLC, P.O. BOX 361131 CLEVELAND, OHIO 44136-0019; Phone: 1-800-949-4483