

For Kawasaki Discount Parts Call 606-678-9623 or 606-561-4983

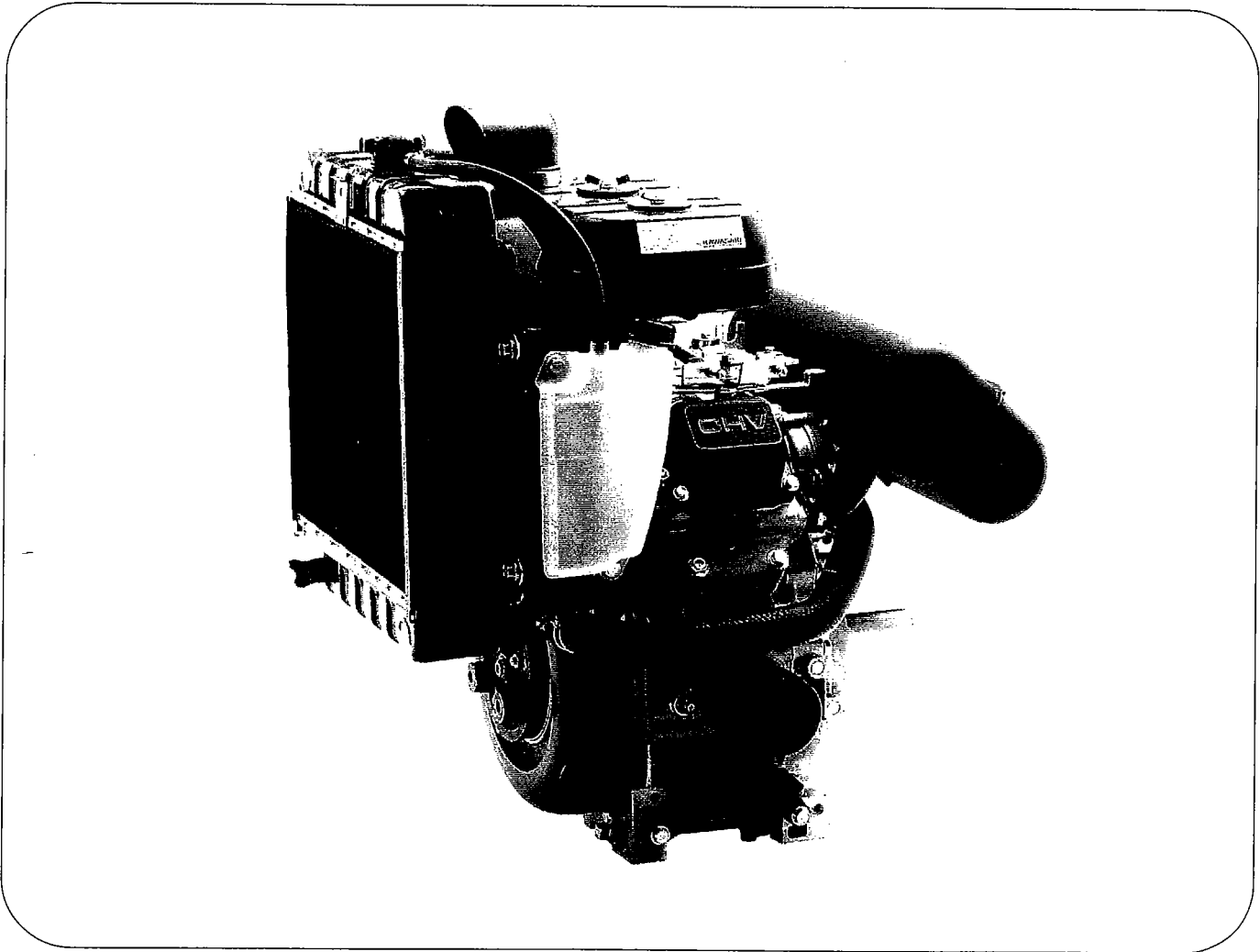

FD620D
FD661D











4-stroke liquid-cooled v-twin gasoline engine

Service Manual

www.mymowerparts.com

For Kawasaki Discount Parts Call 606-678-9623 or 606-561-4983

Quick Reference Guide

General Information	1	
Fuel System	2	
Cooling System	3	
Engine Top End	4	
Lubrication System	5	
Camshaft / Crankshaft	6	
Electric System	7	
Trouble Shooting	8	
Supplement - FD661D MODEL	9	

This quick reference guide will assist you in locating a desired topic or procedure.

- Bend the pages back to match the black tab of the desired chapter number with the black tab on the edge at each table of contents page.
- Refer to the sectional table of contents for the exact pages to locate the specific topic required.

For Kawasaki Discount Parts Call 606-678-9623 or 606-561-4983



FD620D
FD661D

4-stroke liquid cooled v-twin gasoline engine

Service Manual

All rights reserved. No parts of this publication may be reproduced, stored in a retrieval system, or transmitted in any form or by any means, electronic mechanical photocopying, recording or otherwise, without the prior written permission of Quality Assurance Department/Consumer Products & Machinery Group/Kawasaki Heavy Industries, Ltd., Japan.

No liability can be accepted for any inaccuracies or omissions in this publication, although every possible care has been taken to make it as complete and accurate as possible.

The right is reserved to make changes at any time without prior notice and without incurring an obligation to make such changes to products manufactured previously.

All information contained in this publication is based on the latest product information available at the time of publication. Illustrations and photographs in this publication are intended for reference use only and may not depict actual model component parts.

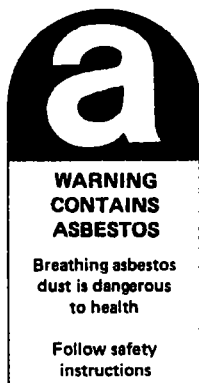

**WARNING
CONTAINS
ASBESTOS**

Breathing asbestos
dust is dangerous
to health

Follow safety
instructions

This warning may apply to any of the following components or any assembly containing one or more of these components:-

- Brake Shoes or Pads
- Clutch Friction Material
- Gaskets
- Insulators

SAFETY INSTRUCTIONS

- Operate if possible out of doors or in a well ventilated place.
- Preferably use hand tools or low speed tools equipped, if necessary, with an appropriate dust extraction facility. If high speed tools are used, they should always be so equipped.
- If possible, dampen before cutting or drilling.
- Dampen dust and place it in properly closed receptacle and dispose of it safely.

LIST OF ABBREVIATIONS

A	ampere(s)	lb	pound(s)
ABDC	after bottom dead center	m	meter(s)
AC	alternating current	min	minute(s)
ATDC	after top dead center	N	newton(s)
BBDC	before bottom dead center	Pa	pascal(s)
BDC	bottom dead center	PS	horsepower
BTDC	before top dead center	psi	pound(s) per square inch
°C	degree(s) Celsius	r	revolution
DC	direct current	rpm	revolution(s) per minute
F	farad(s)	TDC	top dead center
°F	degree(s) Fahrenheit	TIR	total indicator reading
ft	foot, feet	V	volt(s)
g	gram(s)	W	watt(s)
h	hour(s)	Ω	ohm(s)
L	liter(s)		

Read OWNER'S MANUAL before operating.

Foreword

This manual is designed primarily for use by trained mechanics in a properly equipped shop. However, it contains enough detail and basic information to make it useful to the owner who desires to perform his own basic maintenance and repair work. A basic knowledge of mechanics, the proper use of tools, and workshop procedures must be understood in order to carry out maintenance and repair satisfactorily. Whenever the owner has insufficient experience or has doubts as to his ability to do the work, all adjustments, maintenance, and repair should be carried out only by qualified mechanics.

In order to perform the work efficiently and to avoid costly mistakes, read the text, thoroughly familiarize yourself with the procedures before starting work, and then do the work carefully in a clean area. Whenever special tools or equipment are specified, do not use makeshift tools or equipment. Precision measurements can only be made if the proper instruments are used, and the use of substitute tools may adversely affect safe operation.

To get the longest life out of your engine:

- Follow the Periodic Maintenance Chart in the Service Manual.
- Be alert for problems and non-scheduled maintenance.
- Use proper tools and genuine Kawasaki engine parts. Genuine parts provided as spare parts are listed in the Parts Catalog.
- Follow the procedures in this manual carefully. Don't take shortcuts.
- Remember to keep complete records of maintenance and repair with dates and any new parts installed.

How to Use this Manual

In preparing this manual, we divided the product into its major systems. These systems became the manual's chapters. All information for a particular system from adjustment through disassembly and inspection is located in a single chapter.

The Quick Reference Guide shows you all of the product's system and assists in locating their chapters. Each chapter in turn has its own comprehensive Table of Contents.

The Periodic Maintenance Chart is located in the General Information chapter. The chart gives a time schedule for required maintenance operations.

If you want spark plug information, for example, go to the Periodic Maintenance Chart first. The chart tells you how frequently to clean and gap the plug. Next, use the Quick Reference Guide to locate the electric System chapter. Then, use the Table of Contents on the first page of the chapter to find the Spark Plug section.

Whenever you see these WARNING and CAUTION symbols, heed their instructions! Always follow safe operating and maintenance practices.

▲WARNING

This warning symbol identifies special instructions or procedures which, if not correctly followed, could result in personal injury, or loss of life.

CAUTION

This caution symbol identifies special instructions or procedures which, if not strictly observed, could result in damage to or destruction of equipment.

This manual contains four more symbols (in addition to WARNING and CAUTION) which will help you distinguish different types of information.

NOTE

- *This note symbol indicates points of particular interest for more efficient and convenient operation.*
- Indicates a procedural step or work to be done.
- Indicates a procedural sub-step or how to do the work of the procedural step it follows. It also precedes the text of a WARNING, CAUTION, or NOTE.
- ★ Indicates a conditional step or what action to take based on the results of the test or inspection in the procedural step or sub-step it follows.

In most chapters an exploded view illustration of the system components follows the Table of Contents. In these illustrations you will find the instructions indicating which parts require specified tightening torque, oil, grease or a locking agent during assembly.

General Information

Table of Contents

Before Servicing	1-2
Model Identification	1-5
General Specifications	1-6
Periodic Maintenance Chart except U.S.	1-7
Periodic Maintenance Chart for U.S.	1-8
Torque and Locking Agent	1-9

1-2 GENERAL INFORMATION

Before Servicing

Before starting to service the engine, carefully read the applicable section to eliminate unnecessary work. Photographs, diagrams, notes, cautions, warnings, and detailed descriptions have been included wherever necessary. Nevertheless, even a detailed account has limitations, a certain amount of basic knowledge is required for successful work.

Especially note the following:

(1) Dirt

Before removal and disassembly, clean the engine. Any dirt entering the engine, carburetor, or other parts, will work as an abrasive and shorten the life of engine. For the same reason, before installing a new part, clean off any dust or metal filings.

(2) Battery Ground

Remove the ground (-) lead from the battery before performing any disassembly operations on the equipment. This prevents:

- (a) the possibility of accidentally turning the engine over while partially disassembled.
- (b) sparks at electrical connections which will occur when they are disconnected.
- (c) damage to electrical parts.

(3) Tightening Sequence

Generally, when installing a part with several bolts, nuts, or screws, start them all in their holes and tighten them to a snug fit. Then tighten them evenly, in a staggered sequence. This is to avoid distortion of the part and/or causing gas or oil leakage. Conversely, when loosening the bolts, nuts, or screws, first loosen all of them by about a quarter of a turn and then remove them. Where there is a tightening sequence indication in this Service Manual, the bolts, nuts, or screws must be tightened in the order and method indicated.

(4) Torque

When torque values are given in this Service Manual, use them. Either too little or too much torque may lead to serious damage. Use a good quality, reliable torque wrench.

(5) Force

Common sense should dictate how much force is necessary in assembly and disassembly. If a part seems especially difficult to remove or install, stop and examine what may be causing the problem. Whenever tapping is necessary, tap lightly using a wooden or plastic-faced mallet. Use an impact driver for screws (particularly for the removal of screws held by a locking agent) in order to avoid damaging the heads.

(6) Edges

Watch for sharp edges, especially during major engine disassembly and assembly. Protect your hands with gloves or a piece of thick cloth when lifting the engine or turning it over.

(7) High-Flash Point Solvent

A high-flash point solvent is recommended to reduce fire danger. A commercial solvent commonly available in North America is Stoddard solvent (generic name). Always follow manufacturer and container directions regarding the use of any solvent.

(8) Gasket, O-Ring

Do not reuse a gasket or O-ring once it has been in service. The mating surfaces around the gasket should be free of foreign matter and perfectly smooth to avoid oil or compression leaks.

(9) Liquid Gasket, Non-Permanent Locking Agent

Follow manufacturer's directions for cleaning and preparing surfaces where these compounds will be used. Apply sparingly. Excessive amounts may block engine oil passages and cause serious damage. An example of a non-permanent locking agent commonly available in North America is Loctite Lock'n Seal (Blue).

(10) Press

A part installed using a press or driver, such as a journal, should first be coated with oil on its outer or inner circumference so that it will go into place smoothly.

(11) Ball Bearing

When installing a ball bearing, the bearing race which is affected by friction should be pushed by a suitable driver. This prevents severe stress on the balls and races, and prevents races and balls from being dented. Press a ball bearing until it stops at the stop in the hole or on the shaft.

(12) Oil Seal, Grease Seal

Replace any oil or grease seals that were removed with new ones, as removal generally damages seals.

When pressing in a seal which has manufacturer's marks, press it in with the marks facing out. Seals should be pressed into place using a suitable driver, which contacts evenly with the side of seal, until the face of the seal is even with the end of the hole.

(13) Seal Guide

A seal guide is required for certain oil or grease seals during installation to avoid damage to the seal lips. Before a shaft passes through a seal, apply a little oil, preferably high temperature grease on the lips to reduce rubber to metal friction.

(14) Circlip, Retaining Ring

Replace any circlips and retaining rings that were removed with new ones, as removal weakens and deforms them. When installing circlips and retaining rings, take care to compress or expand them only enough to install them and no more.

(15) Cotter Pin

Replace any cotter pins that were removed with new ones, as removal deforms and breaks them.

(16) Lubrication

Engine wear is generally at its maximum while the engine is warming up and before all the rubbing surfaces have an adequate lubricative film. During assembly, oil or grease (whichever is more suitable) should be applied to any rubbing surface which has lost its lubricative film. Old grease and dirty oil should be cleaned off. Deteriorated grease has lost its lubricative quality and may contain abrasive foreign particles.

Don't use just any oil or grease. Some oils and greases in particular should be used only in certain applications and may be harmful if used in an application for which they are not intended. This manual makes reference to molybdenum disulfide grease (MoS₂) in the assembly of certain engine parts. Always check manufacturer recommendations before using such special lubricants.

(17) Electrical Wires

All the electrical wires are either single-color or two-color and, with only a few exceptions, must be connected to wires of the same color. On any of the two-color wires there is a greater amount of one color and a lesser amount of a second color, so a two-color wire is identified by first the primary color and then the secondary color. For example, a yellow wire with thin red stripes is referred to as a "yellow/red" wire; it would be a "red/yellow" wire if the colors were reversed to make red the main color.

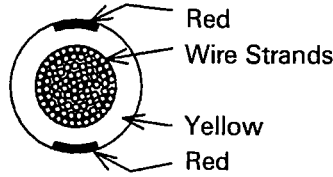
Wire (cross-section)	Name of Wire Color
	Yellow/Red

(18) Replacement Parts

When there is a replacement instruction, replace these parts with new ones every time they are removed. These replacement parts will be damaged or lose their original function once removed.

(19) Inspection

When parts have been disassembled, visually inspect these parts for the following conditions or other damage. If there is any doubt as to the condition of them, replace them with new ones.

- | | | | |
|--------------|---------------|-----------|------|
| Abrasion | Crack | Hardening | Warp |
| Bent | Dent | Scratch | Wear |
| Color change | Deterioration | Seizure | |

(20) Specifications

Specification teams are defined as follows:

"Standards": show dimensions or performances which brand-new parts or systems have.

"Service Limits" Indicate the usable limits. If the measurement shows excessive wear or deteriorated performance, replace the damaged parts.

1-4 GENERAL INFORMATION

KAWASAKI Hand Tester :

KAWASAKI Hand Tester (P/N 57001-1394) is recommended for the electrical system check because a meter of other type may indicate different value.

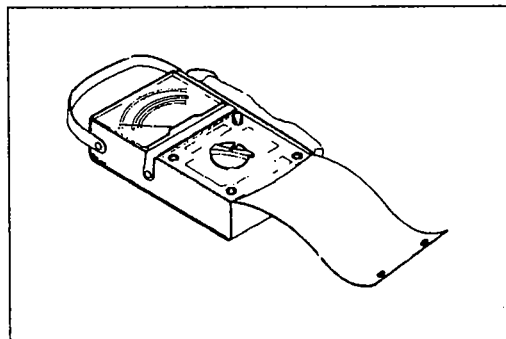

Model Identification

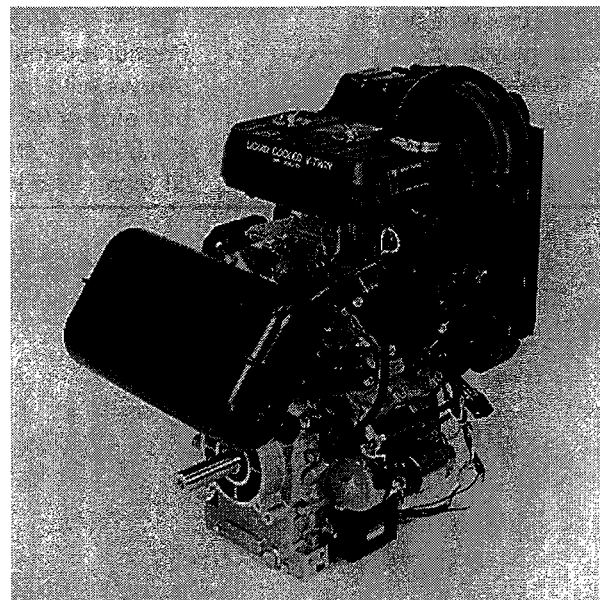
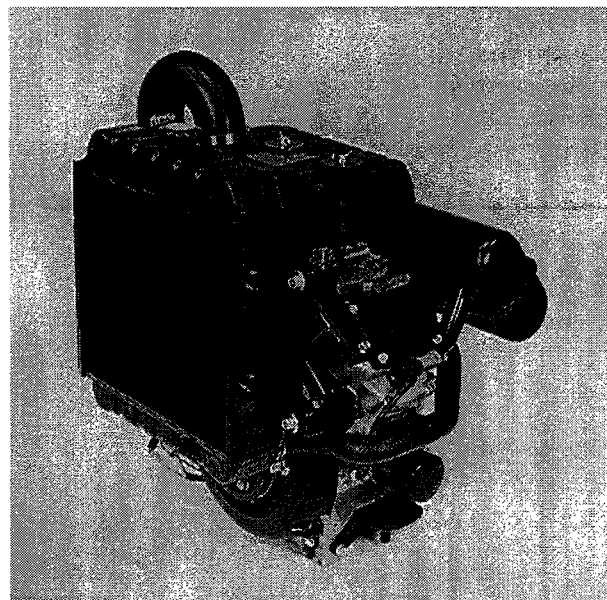
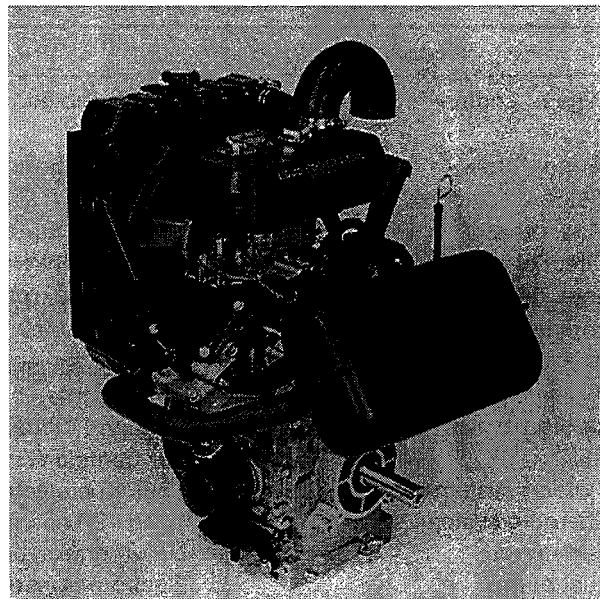
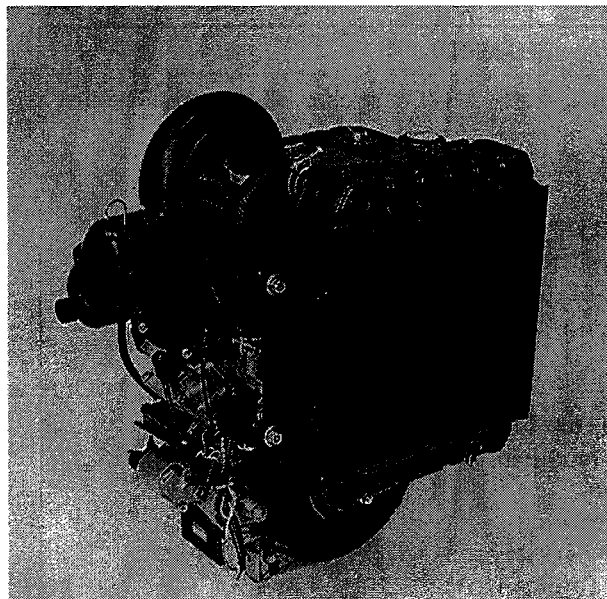

Cylinder Number Designation:

- No.1 Cyl. is the right-hand cylinder viewed from the flywheel.
- No.2 Cyl. is the left-hand cylinder viewed from the flywheel.

1-6 GENERAL INFORMATION

General Specifications

Items	FD620D
Type of engine	Liquid-cooled, Horizontal shaft, OHV, 4-stroke, 90°V-twin, Gasoline engine.
Bore x Stroke	76 mm x 68 mm (2.99 in x 2.66 in)
Piston displacement	617 mL (37.7 cu. in)
Max. output	14.9 kW/3 600 rpm (20 HP/3 600 rpm)[SAE J1349]
Direction of rotation	Counterclockwise facing PTO shaft end
Low idle speed except U.S.	1550 ± 100 (rpm)
Low idle speed for U.S.	1450 (rpm) to 1650 (rpm)
High idle speed except U.S.	3600 ± 75(rpm)
High idle speed for U.S.	3600 (rpm)
Ignition system	Battery, Full transistor, Fixed timing
RFI	Per Canada and U.S.A. requirements
Starting system	Shift type electric starter
Charging system	12 V - 20 amps with regulator
Carburetor	Down draft type, Fixed main jet
Fuel pump	Electro magnetic pump (in-line type)
Air cleaner	Dual stage element
Governor	All speed mechanical fly weights
Lubrication system	Pressure feed by positive displacement pump
*Oil filter	Cartridge type full flow filter
*Oil pressure switch	ON-OFF switch
Cooling system	Pressurized forced circulation type
*Radiator	3-rows with louverless corrugated fin
Dimensions (H x W x L)	624 mm x 448 mm x 556 mm (24.6 in x 17.6 in x 21.9 in)
Dry weight	41.5 kg (91.5 lb)

*Specifications are subject to change without notice.

Periodic Maintenance Chart except U.S.

To ensure satisfactory operation over an extended period of time, any engine requires normal maintenance regular intervals. The Periodic Maintenance Chart below shows periodic inspection and maintenance items and suitable intervals. The bullet mark (●) designates that the corresponding item should be performed at that interval.

Some adjustments require the use of special tools or other equipment. An electronic tachometer will facilitate setting idle and running speeds.

▲WARNING

Always remove the spark plug cap from spark plug when servicing the engine to prevent accidental starting.

MAINTENANCE	INTERVAL							
	Daily	First 20 hr.	Every 25 hr.	Every 50 hr.	Every 100 hr.	Every 200hr.	Every 300hr	Every 400 hr.
Check and add engine oil, coolant and fuel	●							
Check for loose or lost nuts and screws	●							
Check for fuel, oil and coolant leakage	●							
Check battery electrolyte level	●							
Check or clean air intake screen	●							
Clean air cleaner foam element (1)				●				
Clean air cleaner paper element (1)					●			
Change engine oil		●			●			
Tighten nuts and screws					●			
Clean and regap spark plug					●			
Change oil filter		●				●		
Change air cleaner paper element (1)							●	
Change spark plugs							●	
Clean combustion chamber*							●	
Inspect radiator and hoses*						●		
Check fan belt conditions and tension*						●		
Change coolant*								●
Valve maintenance*							●	
Check and lap valve seating surface*							●	

(1) Service more frequently under dusty conditions.

* These items must be performed with the proper tools. See your authorized Kawasaki engine dealer for service, unless you have the proper equipment and mechanical proficiency.

1-8 GENERAL INFORMATION

Periodic Maintenance Chart for U.S.

To ensure satisfactory operation over an extended period of time, any engine requires normal maintenance regular intervals. The Periodic Maintenance Chart below shows periodic inspection and maintenance items and suitable intervals. The bullet mark (●) designates that the corresponding item should be performed at that interval.

Some adjustments require the use of special tools or other equipment. An electronic tachometer will facilitate setting idle and running speeds.

▲ WARNING

Always remove the spark plug cap from spark plug when servicing the engine to prevent accidental starting.

MAINTENANCE	INTERVAL							
	Daily	First 8 hr.	Every 25 hr.	Every 50 hr.	Every 100 hr.	Every 200hr.	Every 300hr	Every 400 hr.
Check and add engine oil	●							
Check for loose or lost nuts and screws	●							
Check for fuel and oil leakage	●							
Check battery electrolyte level	●							
Check or clean air intake screen	●							
Tighten nuts and screws			●					
★ Clean air cleaner foam element			●					
★ Clean air cleaner paper element					●			
Clean fuel filter element				●				
Change engine oil (without oil filter)		●		●				
Change engine oil (with oil filter)		●			●			
Clean and regap spark plug					●			
Change oil filter						●		
★ Replace air cleaner paper element							●	
★ Clean dust and dirt from cylinder and cylinder head fins							●	
K Clean combustion chamber							●	
K Check and adjust valve clearance							●	
K Clean and lap valve seating surface							●	
K Inspect radiator and hoses						●		
K Check fan belt conditions and tension						●		
K Change coolant								●

Note: The service intervals indicated are to be used as a guide. Service should be performed more frequently as necessary by operating condition.

★ : Service more frequently under dusty conditions.

K : Have an authorized Kawasaki engine dealer perform those services.

Torque and Locking Agent

The following tables list the tightening torque for the major fasteners, and the parts requiring use of a non-permanent locking agent or liquid gasket.

Letters used in the "Remarks" column mean*

- L : Apply a non-permanent locking agent to the threads.
- M : Apply a molybdenum disulfide lubricant (grease or oil) to the threads, seated surface, or washer.
- O : Apply an oil to the threads, seated surface, or washer.
- S : Tighten the fasteners following the specified sequence.

Fastener	Torque			Remarks
	N-m	kg-m	ft-lb	
Fuel System:				
Carburetor Mounting Nuts	17.0	1.7	12.0	
Governor Arm Nut	7.8	0.8	69 in-lb	
Fuel Shut-Off Solenoid Valve	9.8	1.0	7.0	
Cooling System:				
Radiator Mounting Bolts	17.0	1.7	12.0	
Cooling Fan Shaft Nut	20.0	2.0	14.5	
Water Pump Cover Bolts	7.8	0.8	69 in-lb	
Thermo Switch	27.0	2.8	20.0	L
Engine Top End:				
Cylinder Head Bolts and Nuts	21.0	2.1	15.0	S
Valve Clearance Adjust Nuts	8.8	0.9	78 in-lb	
Spark Plugs	25.0	2.5	18.0	
Lubrication System:				
Oil Drain Plug	23.0	2.3	16.5	
Oil Pressure Switch	15.0	1.5	11.0	L
Camshaft/Crankshaft:				
Case Cover to Block Bolts	21.0	2.1	15.0	S
Con-Rod Cap Bolts	21.0	2.1	15.0	O
Electrical System:				
Flywheel Nut	110.0	11.0	80.0	
Starter Motor "B" Terminal	9.8	1.0	7.0	

The table below, relating tightening torque to thread diameter, lists the basic torque for the bolts and nuts. Use this table for only the bolts and nuts which do not require a specific torque value. All of the values are for use with dry solvent-cleaned threads.

Basic Torque General Fasteners

Threads dia. (mm)	Torque		
	N-m	kg-m	ft-lb
4	1.2 ~ 2.2	0.12 ~ 0.22	10 ~ 19 in-lb
5	3.4 ~ 4.9	0.35 ~ 0.50	30 ~ 43 in-lb
6	5.9 ~ 7.8	0.60 ~ 0.80	52 ~ 69 in-lb
8	14 ~ 19	1.4 ~ 1.9	10 ~ 14

For Kawasaki Discount Parts Call 606-678-9623 or 606-561-4983

Fuel System

Table of Contents

Exploded View	2-2
Specifications	2-4
Governor Link Mechanism	2-5
Control Panel Assembly/Removal	2-5
Control Panel Assembly Installation Notes	2-5
Governor Arm Removal	2-5
Governor Arm Installation	2-5
Governor Assembly Removal	2-6
Governor Assembly Installation Notes	2-6
Governor Assembly Inspection	2-6
Governor Shaft Removal	2-6
Governor Shaft Installation Notes	2-7
Carburetor	2-8
Fuel and Air Flow	2-8
Fuel Shut Off Solenoid Valve	2-8
Idle Mixture Screw (Pilot Screw) and Idle Speed Adjustment	2-9
Fast Idle Speed Adjustment	2-9
High Altitude Operation	2-10
Main Jet Replacement	2-10
Fuel System Cleanliness Inspection	2-11
Carburetor Removal	2-11
Installation Notes	2-11
Disassembly Assembly Notes	2-12
Cleaning	2-12
Inspection	2-13
Fuel Shut-Off Solenoid Valve Test	2-14
Intake Manifold	2-15
Removal:	2-15
Installation Notes	2-15
Inspection	2-15
Fuel Pump	2-16
Fuel Pump Test	2-16
Air Cleaner	2-17
Element Removal	2-17
Element Installation Notes	2-17
Element Cleaning and Inspection	2-17
Cleaner Body and Bracket Removal	2-18
Cleaner Body and Bracket Installation Notes	2-18
Housing (Case and Body) Inspection	2-18

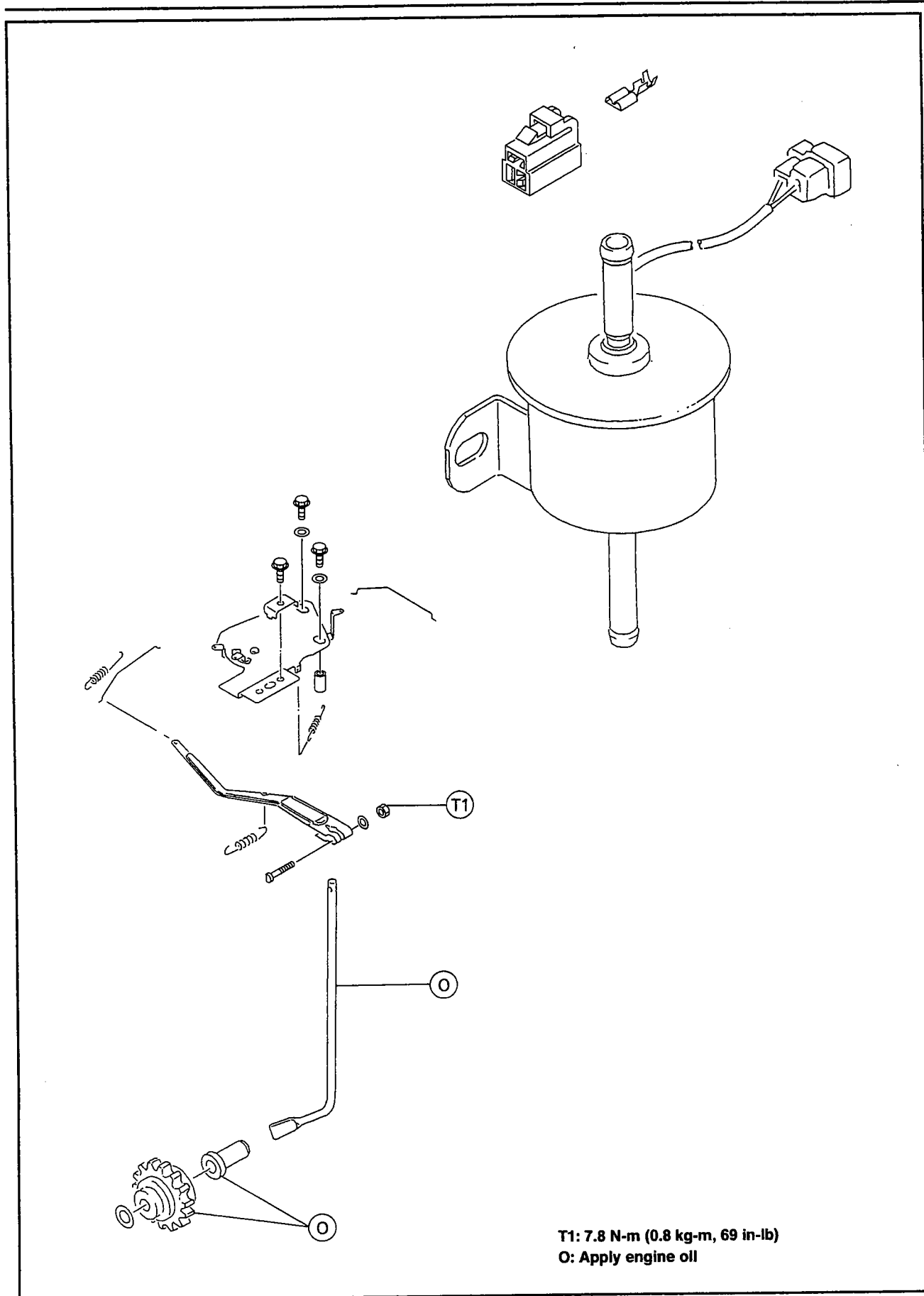

2-4 FUEL SYSTEM

Specifications

Item	Standard
Carburetor Specifications: Make/type Main bore diameter Venturi diameter Main jet (MJ) Pilot jet (PJ) Main air jet (MAJ) Pilot air jet (PAJ) Pilot Screw turns out (PS) (Idle mixture screw turns out) Float level	TEIKEI/FD22K-1A 26 mm (1.02 in) 22 mm (0.87 in) #112 #58 #1.8 #0.9 1 3/4 19 to 21 mm (0.748 to 0.826 in)
Idle Speed except U.S. Low idle speed High idle speed Idle Speed for U.S. Low idle speed High idle speed	1550 ± 100 (rpm) 3600 ± 75 (rpm) 1450 (rpm) to 1650 (rpm) 3600 (rpm)
Air Cleaner: Type Pre-cleaner Two-stage cleaner	Dual stage filtration system Foam element Paper element
Fuel: Fuel requirement except U.S. Fuel requirement for U.S.	Leaded or unleaded automotive grade gasoline Unleaded regular grade gasoline
Fuel Pump: Type Rated voltage Delivery (MIN) Shut-off delivery pressure	Electro-magnetic Pump (in-line type) 12 VDC 400 mL (0.4 qt) / (MIN) at free flow 19.6 to 26.5 kPa (2.8 to 3.8 psi)
Governor: Type	Flyweight all speed governor

Governor Link Mechanism

Control Panel Assembly/Removal

- Remove:
 - Air Cleaner (see Air Cleaner)
 - Muffler (see Muffler Assembly Removal)
 - Carburetor (see Carburetor Removal)
- Unscrew the M6 mounting screws (A) and take off the control panel assembly (B) while unhooking the governor spring (C) end loop at the middle of the governor arm (D).

NOTE

○ Note the position of the different length of the screws. The longer screw has a collar (E) between control panel and the crankcase.

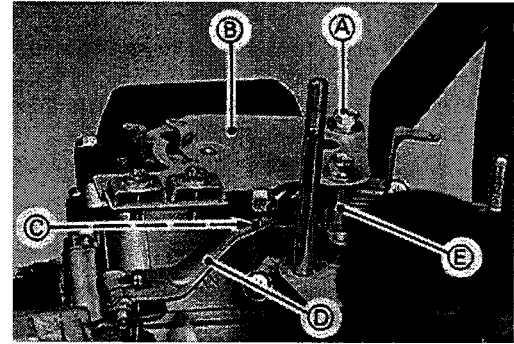

Control Panel Assembly Installation Notes

- Before installing the control panel assembly, check to see that the choke lever and engine speed control lever move smoothly all the ways.
 - ★ If any part is worn or damaged, replace the control panel assembly.
 - After installation, adjust the low and fast idle speeds to the specifications (see Idle Speed and Fast Idle Speed adjustment).
- | | |
|-------------------------------|--------------------|
| A. Choke Lever | C. Choke Spring |
| B. Engine Speed Control Lever | D. Governor Spring |

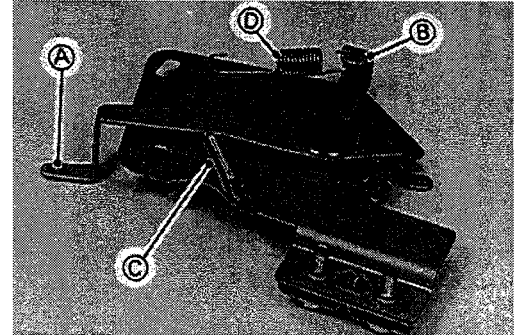

Governor Arm Removal

- Remove:
 - Control Panel Assembly
- Loosen the clamp nut, and take off the governor arm.

A. Clamp Nut	B. Governor Arm
--------------	-----------------

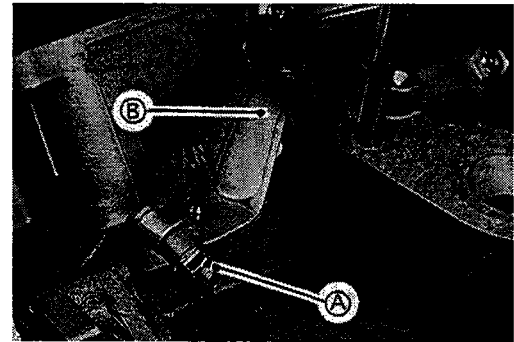

Governor Arm Installation

- Install the governor arm onto the governor shaft temporarily.
- Install the control panel assembly, and connect the governor arm with the governor spring.
- Install the carburetor except for the air cleaner bracket.
- Be sure the link spring around the throttle link rod is in place and that it pulls the governor arm and throttle lever each other.
- Loosen the clamp nut on the governor arm enough to move the governor shaft.
- Turn Top end of the governor arm counterclockwise to fully open the carburetor throttle valve and hold it there.
- Turn the governor shaft counterclockwise by inserting a needle into shaft end hole. Fully turn the shaft to end of its travel and tighten the clamp nut to the specification (see Exploded View).
- Be sure the governor shaft extend from the governor arm is approximately 7mm (0.3in).

- | | |
|----------------------|--------------------|
| 1. Link Spring | 6. Governor Shaft |
| 2. Throttle Link Rod | 7. Clamp Nut |
| 3. Throttle Lever | 8. Small Hole |
| 4. Governor Arm | 9. Governor Sleeve |
| 5. Carburetor | |
- (Control panel is removed for clarity)

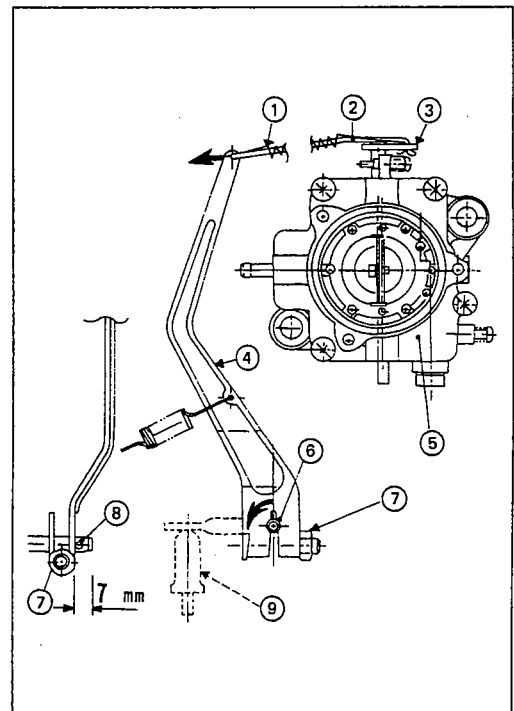

2-6 FUEL SYSTEM

Governor Assembly Removal

- Split the crankcase (see Crankcase Splitting in the Camshaft/Crankshaft chapter).
- Remove the governor assembly (A) with the sleeve (B) by prying the gear with two proper size screw drivers.
- To avoid damaging the parting surface of the casecover, use a suitable soft mats (C) as shown.

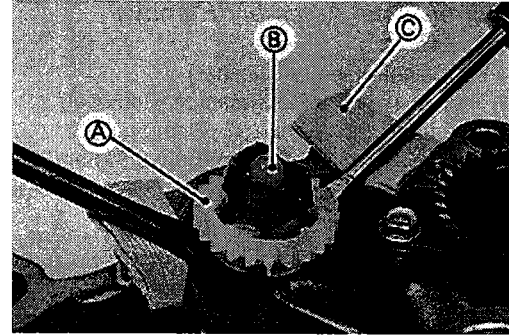

CAUTION

Do not remove the governor assembly unless it is necessary. Once it has been removed, it must be replaced.

- Remove the thrust washer.

Governor Assembly Installation Notes

- Fit the sleeve into the governor assembly, and install them as a set.

NOTE

○ The sleeve and the governor assembly cannot be installed separately. Push the set onto the shaft until inner flange snaps into the groove securely.

1. Sleeve
2. Governor Assembly
3. Inner Flange
4. Thrust Washer
5. Groove
6. Shaft

- Spin the governor assembly by hand and check that the flyweights operate freely and the center sleeve moves outward.

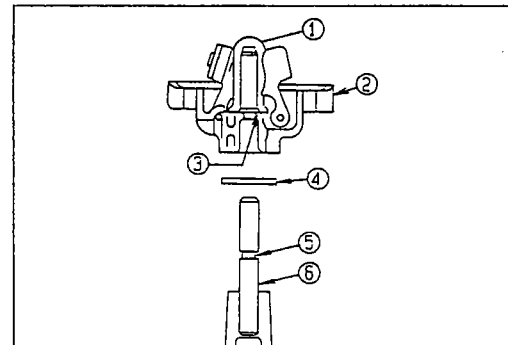

Governor Assembly Inspection

- Visually check the assembly for wear and damage.
- ★ If any part is worn or damaged, replace the assembly.

Governor Shaft Removal

- Remove:
 - Camshaft (see Camshaft Tappet Removal in the camshaft/Crankshaft chapter).
- Unscrew the governor arm clamp nut, and remove the governor arm.
- Turn the governor shaft clockwise 1/4 turn to remove governor shaft.

NOTE

○ It is not necessary to remove the governor shaft unless it is being replaced.

- Replace the oil seal only if the lip shows signs of leakage or it has been damaged.

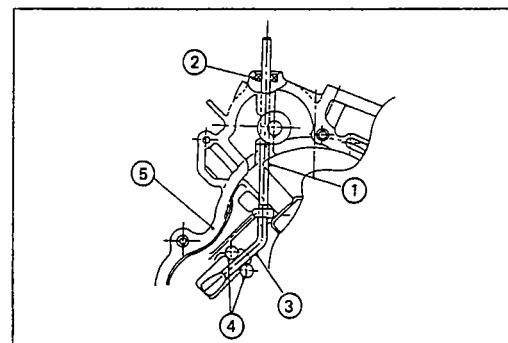

- The oil seal must be assembled with seal lip towards inside of the engine.
- Press in the oil seal 1.0mm (0.04 in) below the crankcase surface.
 1. Governor Shaft
 2. Oil Seal
 3. Shaft Arm
 4. Projections
 5. Crankcase

Governor Shaft Installation Notes

- Install the governor shaft (A) by properly positioning shaft arm between projections (B) as shown (see above PHOTO).

NOTE

- *Install the governor shaft before installing the camshaft to the crankcase.*
- Check that the governor shaft moves freely in its operating range.

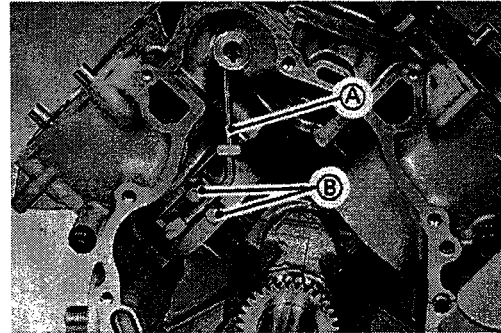

Carburetor

Fuel and Air Flow

The main system of the carburetor consists of the main jet, main nozzle, and the main air passage (main air jet). The main system meters fuel to the engine during moderate to heavy load conditions. Fuel flows through the main jet and into the main nozzle, where it is joined by air from the main air passage (main air jet). The resulting mixture flows out the end of the main nozzle into the carburetor bore, where it is atomized by the high speed air flow, and carried into the engine.

The pilot system includes the pilot jet, pilot screw (Idle mixture screw), pilot air jet, pilot outlet, and the bypass outlet. The pilot system meters the fuel/air mixture while the engine is idling and running under a light load. Under these conditions there is very little air flow through the carburetor bore; so little that it is not enough to draw fuel through the main system of the carburetor and atomize it. Instead, the fuel is drawn through the pilot system, since the nearly closed throttle valve causes high speed air flow past the pilot outlet and bypass holes (even at low engine speed).

Fuel flow in the pilot system is metered by the pilot jet. Air for better atomization is admitted via the pilot air jet in the mouth of the carburetor. The fuel/air mixture passes into the bore of the carburetor downstream of the throttle valve through the bypass holes and pilot outlet. While the throttle valve is almost closed, it covers the small bypass holes opening into the bore from the pilot system. As the throttle valve begins to open, it uncovers the bypass holes, allowing more fuel/air mixture to flow. The extra flow is needed because the engine starts to run faster as the throttle is opened. The pilot screw controls the amount of fuel/air mixture allowed through the pilot outlet, but does not meter the bypass holes. A moderate amount of air comes in around the throttle valve at an idle, so adjusting the pilot screw changes the fuel/air ratio. Turning the pilot screw (Idle mixture screw) out (Counterclockwise) enriches the mixture; turning it in (clockwise) leans the mixture.

- | | |
|------------------|----------------------|
| 1. Main Jet | 8. Bypass Holes |
| 2. Main Air Jet | 9. Pilot Outlet |
| 3. Emersion Tube | 10. Pilot Screw |
| 4. Float | (Idle Mixture Screw) |
| 5. Ball Plugs | 11. Throttle Valve |
| 6. Pilot Jet | 12. Main Nozzle |
| 7. Pilot Air Jet | 13. Plate Plug |

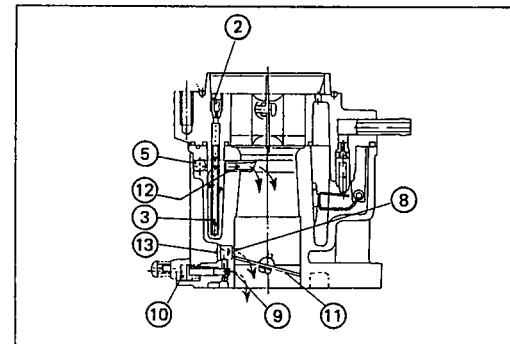
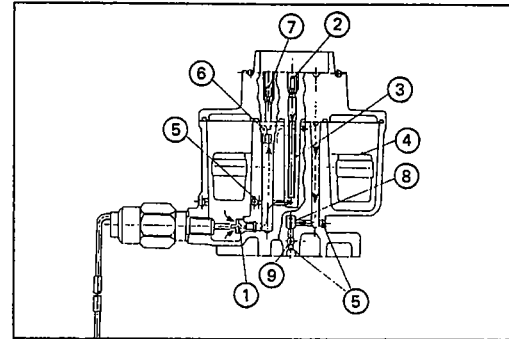
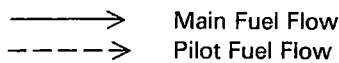

Fuel Shut Off Solenoid Valve

To avoid after firing when stopping the engine, a solenoid actuated fuel shut off valve is installed in the carburetor bowl. The valve shuts off the fuel supply to the main jet simultaneously when the switch key turned to the "OFF" position.

The valve opens automatically when the switch key is turned to the "Run" position.

1. Solenoid Valve
2. Main Jet

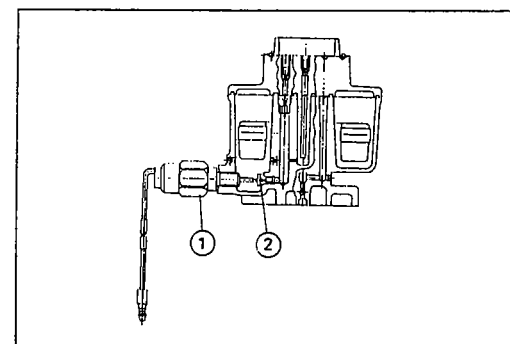

Idle Mixture Screw (Pilot Screw) and Idle Speed Adjustment

CAUTION

Do not attempt to adjust idle mixture screw with air cleaner removed

- Stop the engine.
- Turn the idle mixture screw (A) all the way in until it seats lightly.

CAUTION

Do not turn the idle mixture screw in too far or the carburetor body will be damaged and require replacement

- Back the idle mixture screw out the specified number of turns (1 3/4). This setting is approximately correct. To make fine adjustment, follow the steps below.
- Disconnect all possible external loads from the engine.
- Start the engine and warm it up thoroughly.

▲WARNING

Always keep your hands clear of the moving parts

- Move the throttle lever on dash in the idle position, and hold the throttle lever on the carburetor in closed position (turn the governor arm clockwise all the way) and adjust the idle speed screw (A) until the engine idles at specified speed.
- Keep on throttle lever on the carburetor in the closed position, and search for the point at which the engine speed gets the highest by slowly turning the idle mixture screw in or out and then turn the idle mixture screw back out additional 1/4 turn.
- Make adjustment by turning the idle speed screw so that the engine may be kept at specified idle speed while keeping the throttle lever on the carburetor in the closed position.

Idle Mixture Screw Turns Out

1 3/4 (nearly about)

Idle Speed except U.S.

1550 ± 100 (rpm)

Idle Speed for U.S.

1450 to 1650 (rpm)

NOTE

○ A remote throttle control cable must be made the idle speed respectively correspond to that of the equipment.

- | | |
|---------------------------|-----------------------|
| 1. Throttle Cable | 5. Governor Arm |
| 2. Choke Cable | 6. Idle Speed Screw |
| 3. Idle Position | 7. Idle Mixture Screw |
| 4. Throttle Lever (Carb.) | |

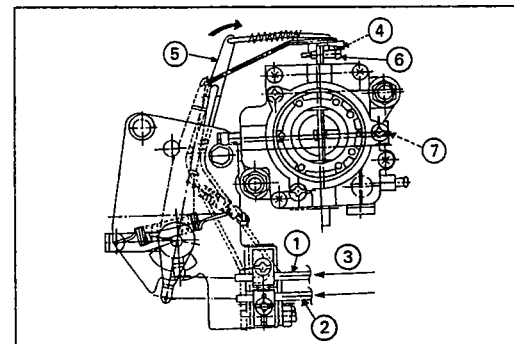
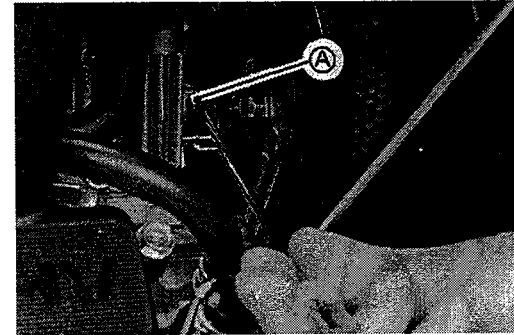
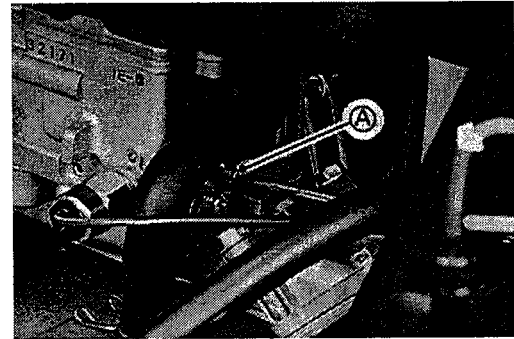

Fast Idle Speed Adjustment

NOTE

○ Fast idle speed adjustment should be made after the idle speed adjustment is performed.

CAUTION

Do not adjust fast idle speed with the air cleaner removed

- Start and warm up the engine thoroughly.

▲WARNING

Always keep your hands clear of the moving parts.

- Move the throttle lever on dash in the fast idle position and leave it there.
- Loosen two M6 control panel mounting bolts enough to move the control panel assembly.
- Carefully move the control panel assembly left or right to obtain the specified fast idle speed.
- Tighten the M6 Mounting bolts.

Fast Speed

3600 ± 75 rpm

- Check the idle speed, and readjust the idle speed if necessary.

CAUTION

Be sure to make the idle and fast idle speeds respectively correspond to those of the equipment.

- A. Control Panel C. Fast Idle
B. M6 Mounting Bolts D. Open Choke
(Air cleaner is removed for clarity)

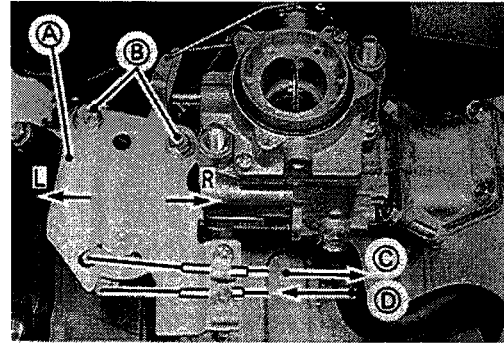

High Altitude Operation

At high altitude, the standard carburetor air-fuel mixture will be excessively rich. Performance will decrease, and fuel consumption will increase. High altitude performance can be improved by installing a smaller diameter main-jet in the carburetor and readjusting the pilot screw (idle mixture screw) to meet good idling and idle speed is the specified rpm.

NOTE

- The main jet high altitude kits are available if the equipment is to be used in the high altitudes. The main jet numbers are stamped on ends of the main jets.

High Altitude Main Jet

Altitude	Main Jet No.
0 ~ 1000 m (0~3000 ft)	#112 (STD)
1000 ~ 2000 m (3000~6000 ft)	#110
2000 m (6000 ft) and higher	#108

Main Jet Replacement

- Place the engine (equipment) on a level surface.
- Close the fuel shut off valve in the equipment.
- Drain the fuel in the carburetor completely by unscrewing the drain screw (C) at the bottom of the float chamber.
- Remove the carburetor (see Carburetor Removal).
- Unscrew the solenoid valve (A), and take off the valve and gasket.
- Using a proper blade screw driver, carefully replace the main jet (B) with a new one for altitude expected.
- Tighten the main jet to the specification (see Carburetor Disassembly Assembly Notes).
- Install the gasket and solenoid valve.

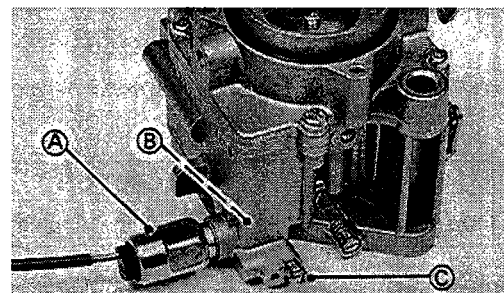

Fuel System Cleanliness Inspection

▲WARNING

Gasoline is extremely flammable and can be explosive under certain conditions. Turn the ignition switch OFF. Do not smoke. Make sure the area is well ventilated and free from any source of flame or sparks; this includes any appliance with a pilot light.

- Place a suitable drain hose (B) under the drain screw (A) on the carburetor.
- Run the lower end of the hose into a container.
- Turn out the drain screw a few turns to drain the carburetor and check to see if water or dirt has accumulated in the carburetor.
- Tighten the drain screw.
- ★ If any water or dirt come out, clean the carburetor (see carburetor Cleaning), and fuel tank, and check the fuel filter.

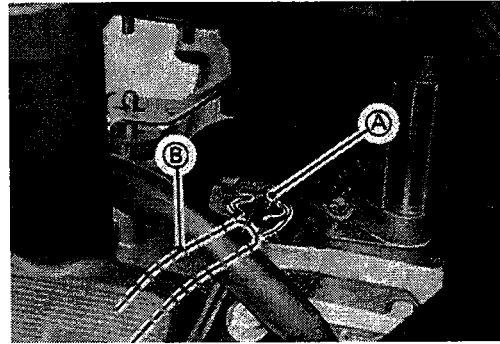

Carburetor Removal

▲WARNING

Gasoline is extremely flammable and can be explosive under certain conditions. Turn the ignition switch OFF. Do not smoke. Make sure the area is well ventilated and free from any source of flame or sparks; this includes any appliance with a pilot light.

- Remove:
 - Air Cleaner and Related Parts (see Air Cleaner).
- Turn the fuel shut off valve to the OFF position.
- Drain the carburetor.
- Disconnect the fuel tube at the fuel inlet joint (A) of the carburetor.
- Disconnect the solenoid valve lead terminal.
- Unscrew the carburetor mounting nuts.
- Unhook the throttle link spring (B) at the governor arm (C) top end with a long nose plier.
- Unhook the throttle and choke link rods (D,E) at the top ends of their arms while lifting off the carburetor.

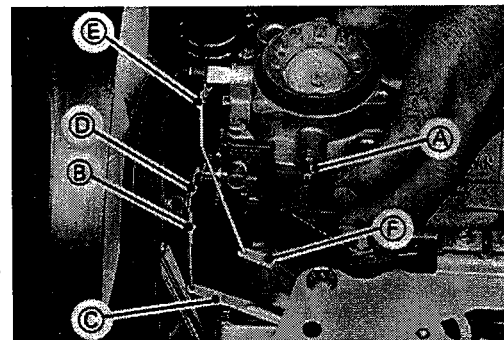

Installation Notes

- Clean the mating surfaces of the carburetor and intake manifold and fit a new gasket.
- Take care not to bend the throttle and choke link rods during installation. Make sure the link spring around the throttle link rod is in place and that it pulls the governor arm and carburetor throttle lever toward each other.
- Adjust:
 - Carburetor Idle Mixture screw
 - Idle Speed

Disassembly Assembly Notes

- Refer to the illustration shown for disassembly and assembly.
- There are a number of the plate or boll plugs in the carburetor. None of these should be removed.
- Turn in the idle mixture screw and count the number of turns until it seats fully but not tightly, and then remove the screw. This is to set the screw to its original position when assembling.
- Turn the idle mixture screw all the way in until it seats lightly, and then back it out the same number of turns counted during disassembly.
- Install the throttle valve on the shaft as the numerical mark on the valve facing out side.
- Note the metering hole in the choke valve, install the choke valve on the shaft so that the metering hole towards fuel inlet joint of the carburetor.
- Drive in the float pin so that the pin extends the same distance on both side of the float hinge bracket.
- The fuel inlet valve seat is pressed into the carburetor body and is not replaceable.
- When assembling the carburetor parts which are attached to the carburetor with the recommended tightening torque of a bolts and screws. (see Exploded View)

- | | |
|----------------------|-------------------------|
| 1. Choke Shaft | 19. Spring |
| 2. Seal | 20. Screws |
| 3. Collar | 21. Throttle Valve |
| 4. Collar | 22. Solenoid Valve |
| 5. Air Hone | 23. Gasket |
| 6. Emarsion Tube | 24. Main Jet |
| 7. Float | 25. Carb. Body |
| 8. Gasket | 26. Carb. Mounting Nuts |
| 9. Pilot Jet | 27. Float Pin |
| 10. Screw | 28. Float Valve |
| 11. Stopper | 29. Screws |
| 12. Throttle Shaft | 30. Pilot Air Jet |
| 13. Seal | 31. O-ring |
| 14. Spring | 32. Screw |
| 15. Idle Speed Screw | 33. Choke Valve |
| 16. Spring | 34. Main Air Jet |
| 17. Pilot Screw | |
| 18. Drain Screw | |

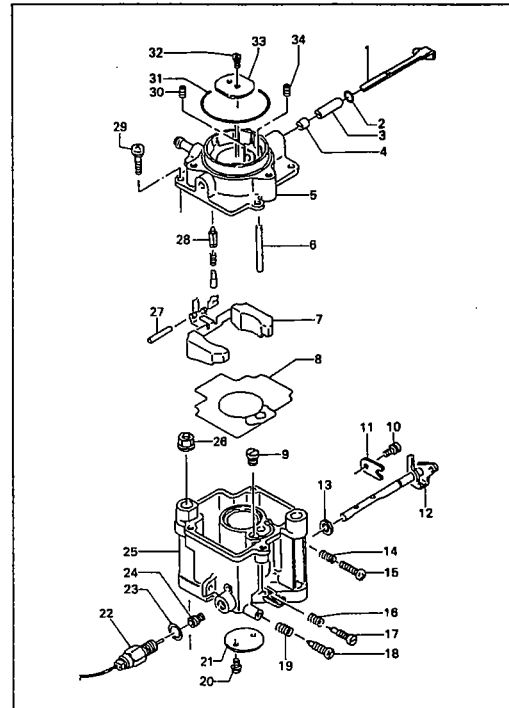

Cleaning

⚠ WARNING

Clean the carburetor in a well-ventilated area and take care that there is no spark or flame anywhere near the working area; this included any appliance with a pilot light. Because of the danger of highly flammable liquids, do not use gasoline or low flash-point solvents to clean the carburetors.

CAUTION

Do not use compressed air on an assembled carburetor, the float may be crushed by the pressure. Remove as many rubber or plastic parts from the carburetor as possible before cleaning the carburetor with a cleaning solution. This will prevent damage or deterioration of the parts. The carburetor body has plastic parts that cannot be removed. Do not use a strong carburetor cleaning solution which could attack these parts; instead, use a mild high flash-point cleaning solution safe for plastic parts. Do not use wire or any other hard instrument to clean carburetor parts, especially jets, as they may be damaged.

- Disassemble the carburetor.
- Immerse all the carburetor metal parts in a carburetor cleaning solution and clean them.
- Rinse the carburetor parts in water and dry them with compressed air.
- Do not use a rags or paper to dry parts. Lint may plug the holes or passages.
- Blow air through the holes and fuel passages with the compressed air. All holes must be open.
- Assemble the carburetor.

Inspection

⚠ WARNING

Gasoline is extremely flammable and can be explosive under certain conditions. Turn the ignition switch OFF. Do not smoke. Make sure the area is well ventilated and free from any source of flame or sparks; this includes any appliance with a pilot light.

- Inspect the carburetor body for damage. Flange sealing surfaces should be smooth and free of burrs and nicks. Replace the gasket if necessary.
- Turn the throttle and choke shafts to check that the throttle and choke butterfly valves move smoothly.
- ★ If the valves do not move smoothly, replace the carburetor body and/or throttle shaft and choke shaft assembly.
- Check that the gasket on the carburetor body.
- ★ If the gasket is not in good condition, replace it.
- Check the other parts of the carburetor for wear or damage. Replace the part if necessary.
- Clean and check the float level as follows.

CAUTION

Do not push down on the float during float level checking.

- With the float (3) assembly installed onto the air hone (1), hold the air hone upside down at an eye level. Gently support the float with a finger and bring it down slowly so that the float arm tab (4) just touches the float valve needle (5). The float lower surface should be parallel with the carburetor body to the air hone mating surfaces (2).
- ★ If the float position is not correct, bend the tab as required for correct adjustment.

Float Level

H = 19 to 21 mm (0.748 to 0.826 in)

- Inspect the inlet needle valve for excessive wear or damage. The tip should be smooth, without any grooves, scratches, or tears. The rod at the other end of the needle should move smoothly when pushed in and released.
- ★ If either the needle or the seat is worn or damaged, replace the float assembly and carburetor body as a set.

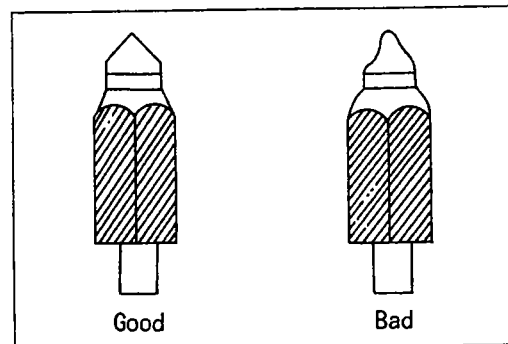
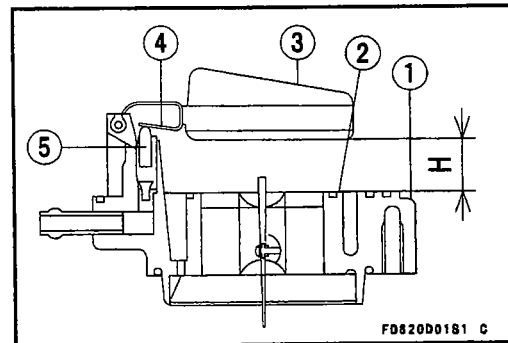

- Inspect the tapered portion (B) of the screw for wear or damage.
- ★ If the pilot screw (A) is worn or damaged, on the taper portion, replace it.
- Check the spring for weakened condition, replace it, if necessary.

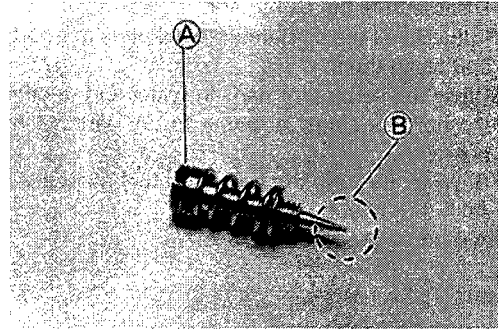

Fuel Shut-Off Solenoid Valve Test

- Unscrew the fuel shut off valve and remove the valve.
- Connect a 12 VDC source to the solenoid as shown.
- ★ If the actuate solenoid plunger (Needle Valve) does not pop in when the Test Voltage is applied, replace it.

NOTE

- If may be necessary to push the plunger slightly for the plunger to withdraw.

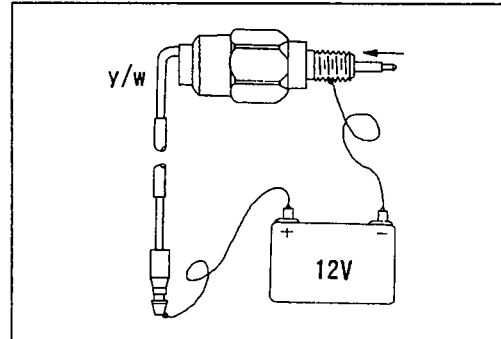

Intake Manifold

Removal:

- Remove:
 - Air Cleaner
 - Carburetor
 - Control Panel Assembly
- Drain the coolant in the engine (see coolant Draining)
- Unscrew the manifold mounting bolts in numerical sequence, 1/4 turn at a time, until all bolts are loose.
- ★ If the mounting bolts removal sequence is not followed, manifold mating surfaces may be warped.
- Remove the manifold and gaskets.

A. No.1 Cyl. Head	C. Gaskets
B. No. 2 Cyl. Head	D. Intake Manifold

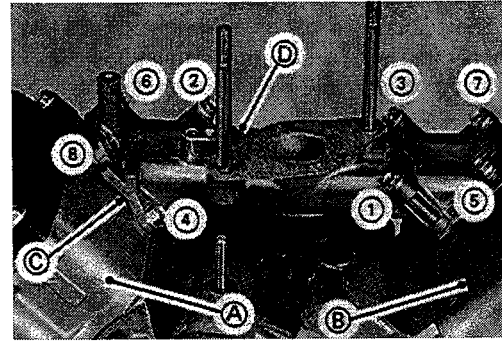

Installation Notes

- Before assembling the manifold, install the cylinder heads on each cylinder and tighten the head bolts in the specified sequence temporarily (see Cylinder Head Installation Notes).
- Place a new gaskets on each mating surface, and install the manifold.
- Follow the sequence shown, tighten the mounting bolts to 4 N-m (35 in-lb).
- Tighten the bolts in sequence 3 N-m (26 in-lb) at a time until the torque on each bolt in 7.8 N-m (69 in-lb).
- Note the position of the different length of bolts.
- Then tighten the cylinder head bolts to the specified torque. (Cylinder Head Assembly Installation Note).

Inspection

- Visually inspect the coolant passage in the manifold for deposits or corrosion in layers inside the passage, clean the passage if necessary.
- An improperly installed gaskets can cause coolant leakage and air drawn into the induction passage. Check the gaskets for correct installation.

NOTE

○ *Small coolant leaks appear only as a rust, corrosion or stain.*

- Inspect the intake manifold for cracks or porous casting.
- Cracks not visible to the eye may be detected by coating the suspected area with mixture of 25 % kerosene and 75 % light engine oil.
- Wipe the area dry and immediately apply a coating of zinc oxide dissolved in wood alcohol. If a cracks is present, the coating will become discolored at the defective area.
- ★ If a cracks is present in the intake manifold, replace it.
- Inspect the gasket surfaces for burrs and nicks.

2-16 FUEL SYSTEM

Fuel Pump

The optional location fuel pump (A) is not installed in the engine when shipped. The fuel pump must be installed onto an equipment as inlet and outlet pipes are horizontal or vertical (Outlet is up side).

- The fuel pump cannot be disassembled, if any damage for the pump is appeared replace it with a new one.

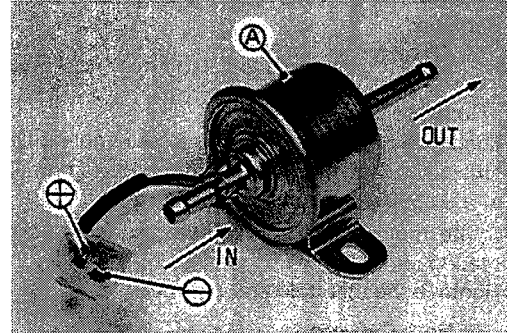

Fuel Pump Test

Before this test, be sure the battery is fully charged.

⚠ WARNING

Gasoline is explosive. Do not expose to spark or flame. Personal injury could result.

- Disconnect and plug the fuel pump outlet pipe.
 - Connect proper pressure gauge to the fuel pump outlet pipe.
 - Turn the engine switch to the "RUN" position, the fuel pump will operate. Record the pressure reading. Stop the fuel pump.
 - Remove the pressure gauge and connect the outlet fuel tube.
 - Disconnect the fuel pump outlet tube from the carburetor inlet.
 - Put the tube end in a graduated container.
 - Run the fuel pump for 30 seconds. Stop the fuel pump. Record the container measurement.
 - Compare the readings to the specifications.
- ★ If low, check for clogged or damaged tubes, fuel filter, or fuel tank. Replace faulty fuel pump.

Minimum Specifications

Fuel Pressure	19kPa (2.76 psi)
Fuel Flow	180mL/30 seconds

Air Cleaner

Element Removal

- Remove the wing bolts, washers and air cleaner case.
- Take off the air cleaner elements from the body.

- | | |
|---------------|-------------|
| A. Wing Bolts | D. Elements |
| B. Washers | E. Body |
| C. Case | |

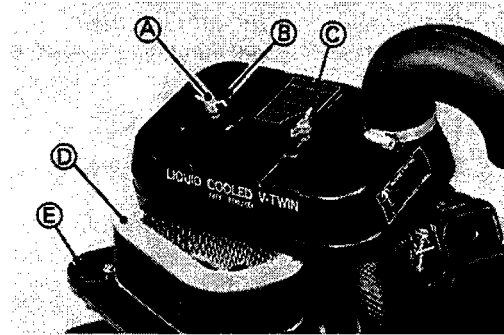

Element Installation Notes

- Install the elements correctly on the air cleaner body.
- The elements can be installed either way on the air cleaner body. Be sure the elements is inplace on the air cleaner body.

Element Cleaning and Inspection

NOTE

- In dusty areas, the elements should be cleaned more frequently than the recommended intervals.

▲ WARNING

Clean the element in a well-ventilated area, and take ample care that there are no sparks or flame anywhere near the working area. Because of the danger of highly flammable liquids, do not use gasoline or a low flash-point solvent to clean the element.

- Remove the air cleaner element, and separate the foam element (A) from the paper element (B).
- Clean the foam element in a bath of detergent and water, and then dry it with compressed air or by shaking it.
- After cleaning, saturate the foam element with clean engine oil, squeeze out the excess, then wrap it in a clean rag and squeeze it as dry as possible. Be careful not to tear the foam element.
- Clean the paper element by tapping it gently on a flat surface to remove dust. If the element is very dirty, replace it with a new one or wash the element in a detergent and water.
- Rinse the element until a water is clear. Let the element air-dry thoroughly before install it.

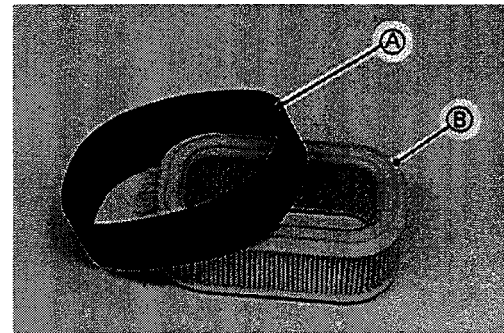

CAUTION

Do not use compressed air to clean the paper element. Do not oil the paper element.

2-18 FUEL SYSTEM

Cleaner Body and Bracket Removal

- Remove the cleaner body mounting screws, spring washers and plain washers.

NOTE

- Do not let the screws, spring washers and plain washers fall into the carburetor bore.
- Pull the breather hose off the pipe at the back of the body, and remove the cleaner body.
- Unscrew the carburetor mounting nuts, then take off the bracket.

- | | |
|-------------------|------------------|
| A. Screws | E. Bracket |
| B. Spring Washers | F. Breather Hose |
| C. Plain Washers | G. Pipe |
| D. Body | H. U-bend Hose |
| | I. Mounting Nuts |

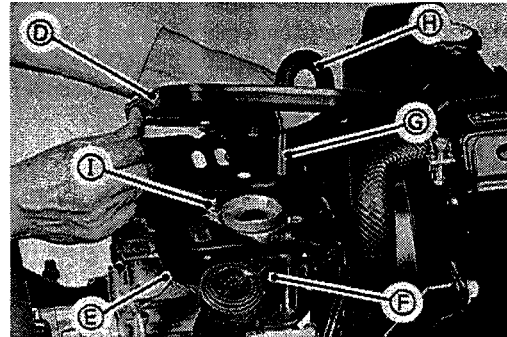
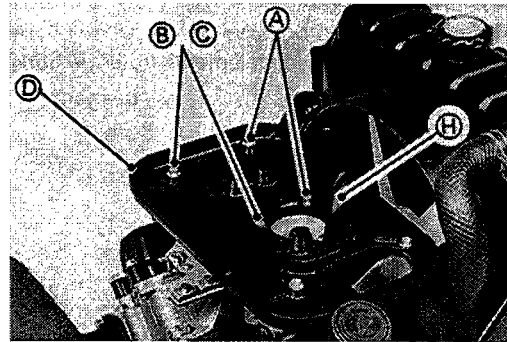

Cleaner Body and Bracket Installation Notes

CAUTION

When assembling the cleaner body onto the bracket, do not let the screws, spring washers and plain washers fall into the carburetor bore.

- Note the positions of different length of screws and different diameter of the plain washers.
- Install the U-bend breather hose so that the end of the hose positions just above the carburetor bore.
- Connect the breather hose from the crankcase to the pipe at the back of the cleaner body.

Housing (Case and Body) Inspection

- Clean the housing with detergent and water and dry thoroughly.
- Check the housing for deformation or other damage. The housing must seal well and permit only filtered air to reach the carburetor.
- ★ If the housing is damaged, it must be replaced.
- Check that no foreign material is obstructing the air passage.

Cooling System

Table of Contents

Exploded View	3-2
Specifications	3-4
Cooling System	3-5
Coolant	3-6
Coolant Deterioration.....	3-6
Coolant Level Inspection.....	3-6
Coolant Draining.....	3-6
Coolant Filling.....	3-7
Air Bleeding	3-8
Visual Leak Inspection.....	3-8
Cooling System Pressure Testing.....	3-8
Flushing.....	3-9
Disassembly and Assembly Precautions	3-9
Water Pump	3-10
Water Pump Removal.....	3-10
Installation Notes.....	3-10
Disassembly	3-10
Pump Parts Inspection	3-11
Assembly Notes	3-11
Radiator	3-12
Removal	3-12
Radiator Inspection.....	3-12
Radiator Cap Inspection.....	3-13
Radiator Hose Inspection.....	3-14
Radiator Hose Installation Notes.....	3-14
Cooling Fan, Fan Belt.....	3-15
Belt Tension Check.....	3-15
Belt Replacement Notes.....	3-15
Removal	3-16
Installation Notes.....	3-16
Inspection	3-16
Fan Bearing Removal	3-17
Fan Bearing Installation Notes.....	3-17
Thermostat.....	3-18
Thermostat Removal.....	3-18
Thermostat Inspection	3-18
Thermo Switch.....	3-19
Thermo Switch Removal and Installation Notes.....	3-19
thermo Switch Inspection	3-19

Exploded View

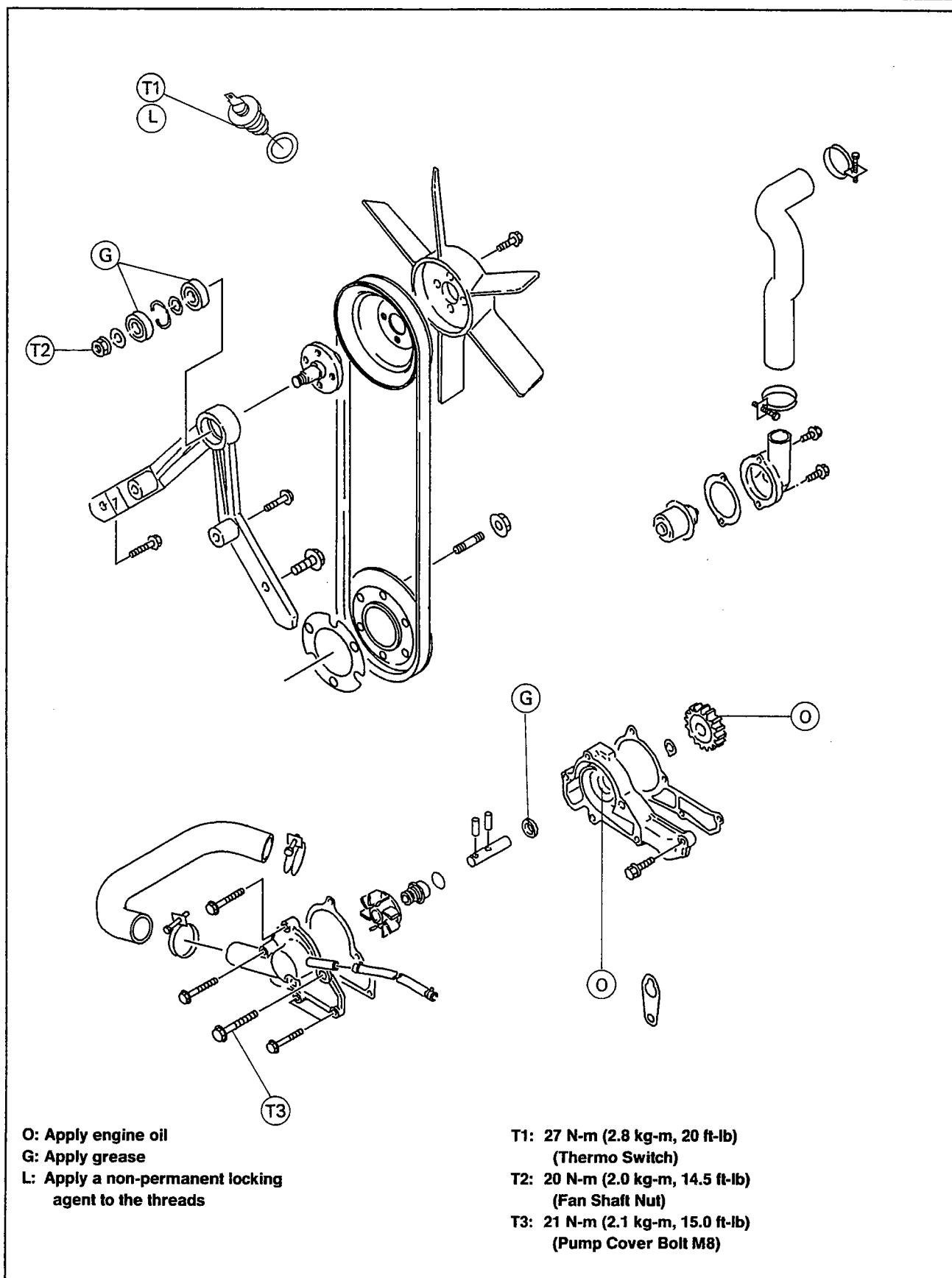

O: Apply engine oil
G: Apply grease
L: Apply a non-permanent locking agent to the threads

T1: 27 N-m (2.8 kg-m, 20 ft-lb)
(Thermo Switch)
T2: 20 N-m (2.0 kg-m, 14.5 ft-lb)
(Fan Shaft Nut)
T3: 21 N-m (2.1 kg-m, 15.0 ft-lb)
(Pump Cover Bolt M8)

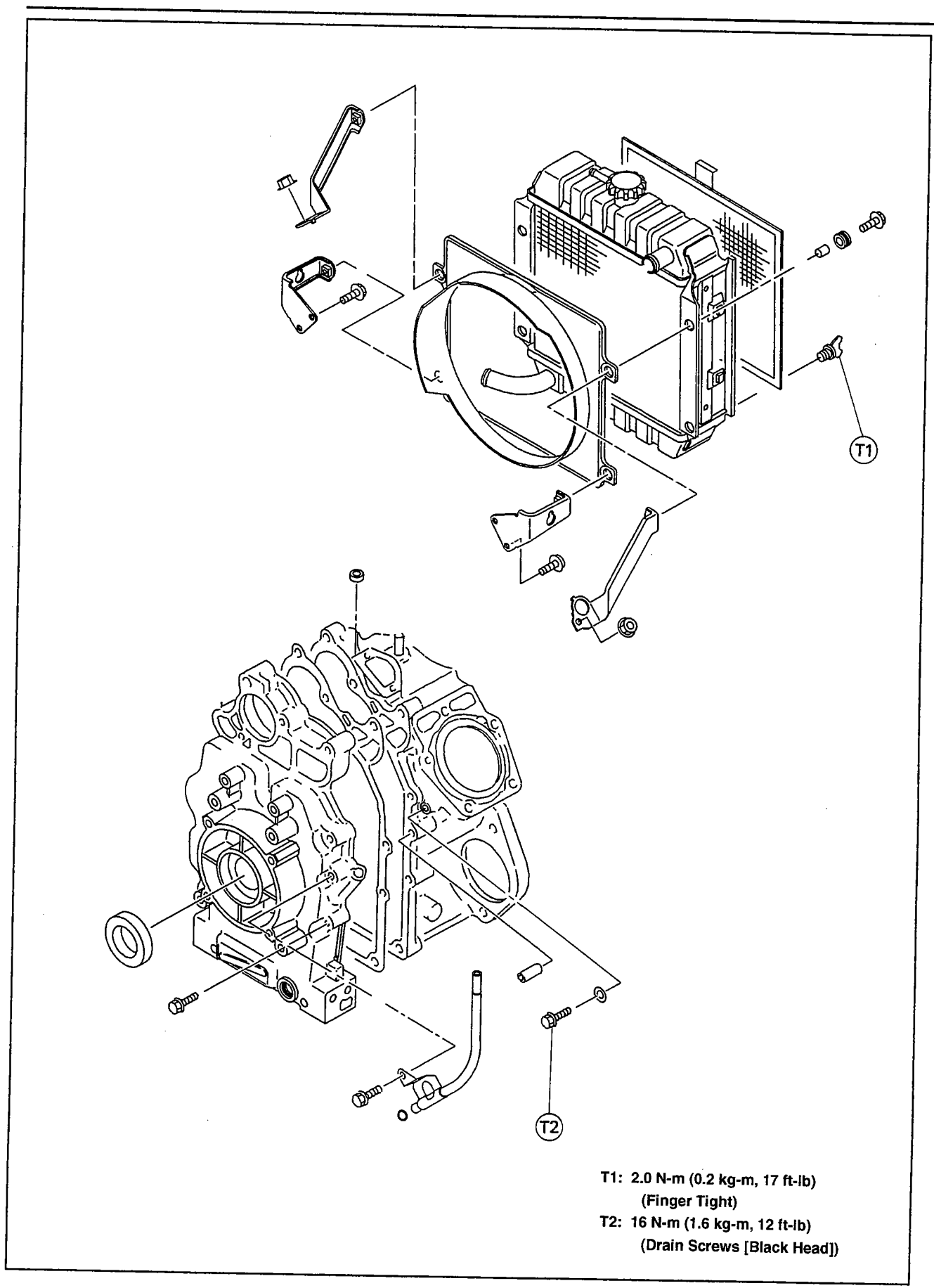

T1: 2.0 N-m (0.2 kg-m, 17 ft-lb)
(Finger Tight)
T2: 16 N-m (1.6 kg-m, 12 ft-lb)
(Drain Screws [Black Head])

3-4 COOLING SYSTEM

Specifications

Item	Standard
*Coolant: Type Color Mixed ratio Freezing point Total amount	Permanent type of antifreeze for aluminum engine and radiator Green 50% solution of ethylene glycol -35°C (-31°F) 2.7 L (0.7 us gallon)
Radiator Cap Relief Pressure: Pressure valve (positive) Vacuum Valve (negative)	73.3 to 102.7 kPa (10.6 to 14.9 psi) 4.90 kPa (0.71 psi)
Thermostat: Valve opening temperature Valve full opening lift	63 to 66°C (145 to 150°F) not less than 7mm (0.28 in) at 80°C (176°F)
Thermo Switch: Detect Temperature	108 to 114°C (226 to 237°F)

*A permanent type of antifreeze is not installed in the cooling system when shipped.

Cooling System

This engine is equipped with a highly efficient pressurized cooling system using a thermostat to maintain an optimum operating temperature. Coolant bypasses the closed thermostat when cold until operating temperature is attained, causing the engine to warm up more quickly. If the coolant temperature becomes too high, a thermo switch on the engine activates the coolant warning lamp to alert the operator or cooling problem.

- 1. Water Pump
- 2. Cylinder Jackets
- 3. Cylinder Heads
- 4. Intake Manifold
- 5. Thermostat
- 6. Bypass Tube
- 7. Thermo Switch
- 8. Radiator
- 9. Radiator Cap
- 10. Cooling Fan
- 11. Cylinder Block

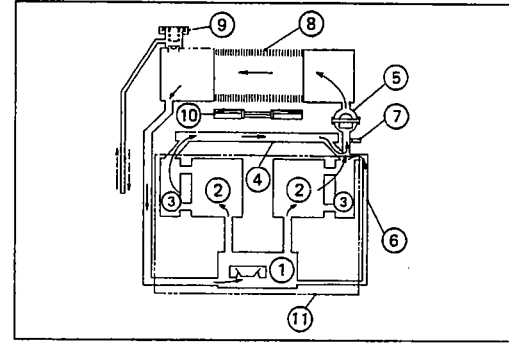

3-6 COOLING SYSTEM

Coolant

Coolant Deterioration

- Visually inspect the coolant in the radiator.
- If whitish cotton-like wafts are observed, aluminum parts in the cooling system are corroded. If the coolant is brown, iron or steel parts are rusting. In either case, flush the cooling system.
- If the coolant gives off an abnormal smell when changing, check for a cooling system leak. It may be caused by exhaust gas leaking in to the cooling system.

Coolant Level Inspection

- Put the engine on a level surface.
- Remove the radiator cap turning it counterclockwise and check the coolant level in the radiator.

⚠ WARNING

Always allow the engine to cool before removing the radiator cap. Then remove the cap slowly and carefully to avoid a possible fast discharge of hot coolant which could cause severe burns.

- Coolant level must be maintained a level of the filler neck bottom (A).
- ★ If the amount of the coolant is insufficient, fill the radiator up to the bottom of the radiator filler neck (A) with the coolant, and install the cap turning it clockwise.

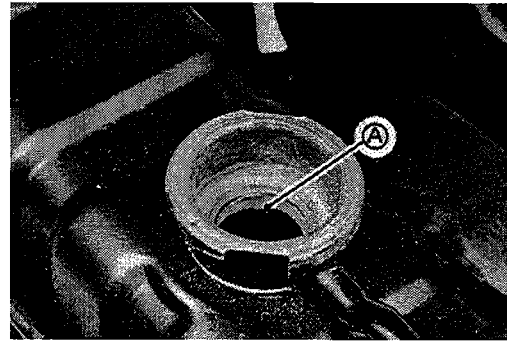

CAUTION

For refilling, add the specified mixture of coolant and soft water. Adding water alone dilutes the coolant and degrades its anticorrosion properties. The diluted coolant can attack the aluminum engine parts. In an emergency, soft water can be added. But the diluted coolant must be returned to the correct mixture ratio within a few days.

If coolant must be added often, there is probably leakage in the cooling system. Check the system for leaks (see Visual Leak Inspection, and pressure Testing).

Coolant Draining

The coolant should be changed periodically to ensure long engine life.

CAUTION

Use coolant containing corrosion inhibitors made specifically for aluminum engines and radiators in accordance with the instructions of the manufactures (see Coolant Filling Section).

⚠ WARNING

To avoid burns do not remove the radiator cap or try to change the coolant when the engine is still hot. Wait until it cools down. Since coolant is harmful to the human body, do not use for drinking.

- Remove the radiator cap (A) as follows.
 - First turn the cap counterclockwise to the first stop and wait there for a few seconds.
 - Push down the cap, then turn the cap counterclockwise to the next stop.
 - Lift off the cap.
- Place a suitable container under the radiator. Turn the drain screw (B) few turns counterclockwise to drain the coolant in the radiator.

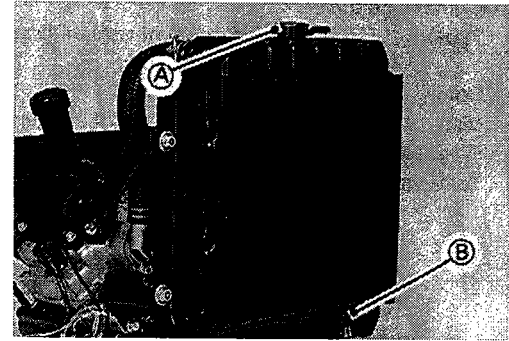

- Remove the muffler (see Muffler Removal).
- Remove one of the cascover mounting bolts (A) which attaches the dipstick tube bracket (B) and cascover to the block together, and then take off the dipstick assembly.
- To drain the coolant in the engine, place a suitable chute under the drain screws (black head) (C) located at the lowest water jacket of the each cylinder to avoid a possible contamination of the starting motor (D) and igniter.
- Inspect the old coolant for color and smell (see Coolant Deterioration).

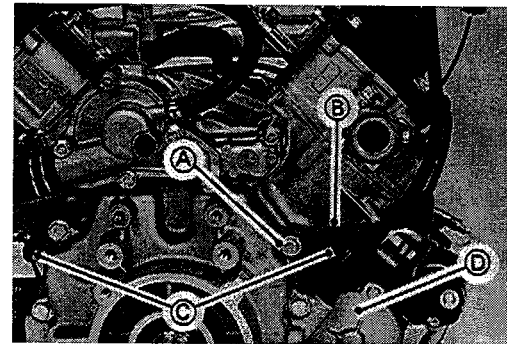

Coolant Filling

- Install the drain plugs. Always replace the gaskets with a new ones, if they are damaged.
- Tighten the drain screws to the specification (see Exploded Views).
- Fill the radiator up to bottom of the radiator filler neck (A) with coolant, and install the cap turning it clockwise.

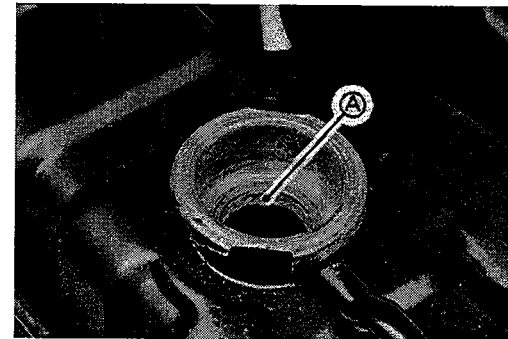

NOTE

- Pour in the coolant slowly so that it can expel the air from the engine and radiator.
- To install the radiator cap, push down it and then turn the cap clockwise to the rest of the way.

CAUTION

Soft or distilled water must be used with the antifreeze in the cooling system. If hard water is used in the system, it causes scales accumulation in the water passages, and considerably reduces the efficiency of the cooling system.

NOTE

- Choose a suitable mixture ratio by referring to the coolant manufacturer's instructions.

3-8 COOLING SYSTEM

Original Coolant

Type:	Permanent type antifreeze for aluminum engine and radiator
Color:	Green
Mixed ratio:	50% solution of ethylene glycol
Freezing Point:	-35°C (-31°F)
Total amount:	2.7L (0.7 U.S. gallon)

Air Bleeding

Before putting the engine into operation, any air trapped in the cooling system must be removed as follows.

- Remove the radiator cap.
- Fill the radiator up to the radiator filler neck with coolant.
- Check the cooling system for leaks.
- Install the radiator cap.
- Start the engine, warm it up thoroughly, and then stop it.
- Check the coolant level in the radiator after the engine cools down.
- ★ If the coolant level is low, add coolant up to the filler neck bottom (A). Install the cap.

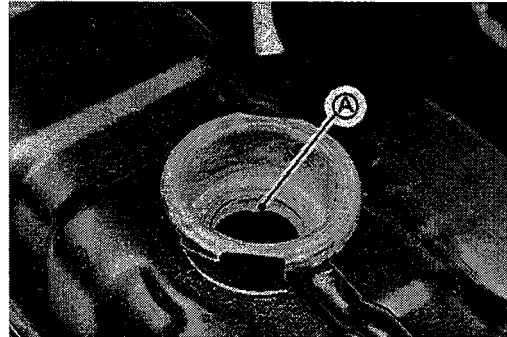

Visual Leak Inspection

Any time the system slowly loses water, inspect for leaks. Small leaks may appear only a rust, corrosion or stain due to evaporation. Watch for these trouble spots.

- Check the water pump housing drainage outlet passage (1) for coolant leaks.
- ★ If the mechanical seal is damaged, the coolant leaks through the seal and drain through the passage. Replace the mechanical seal (2).
- ★ If there are no apparent leaks, pressure test the system.

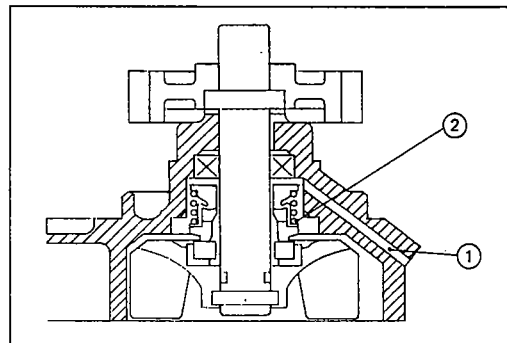

Cooling System Pressure Testing

Air pressure leakage tester can help locate external leaks but they cannot be depended upon to locate small combustion leaks.

CAUTION

During pressure testing, do not exceed the pressure for which the system is designed. The maximum pressure is 97.8 kPa (14.2 psi).

- Remove the radiator cap, and install a cooling system pressure tester (A) on the radiator filler neck.
- Wet the cap sealing surfaces with water or coolant to prevent pressure leaks.
- Build up pressure in the system carefully until the pressure reaches 60 kPa (8.7 psi).
- Watch the pressure gauge for at least 6 seconds. If the pressure holds steady, the system is all right.
- Remove the pressure tester, replenish the coolant, and install the cap.
- ★ If the pressure drops and no external source is found, check for internal leaks. Droplets in the engine oil indicate internal leakage. Check the cylinder head gaskets.

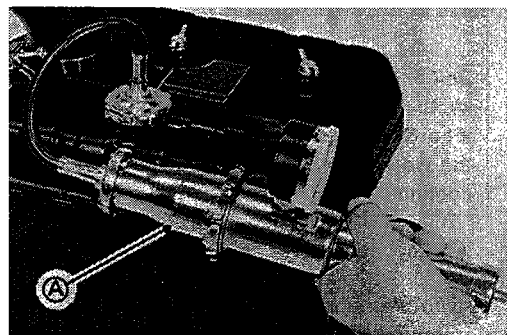

Flushing

Over a period of time, the cooling system accumulates rust, scale, and lime in the water jacket and radiator. When this accumulation is suspected or observed, flush the cooling system. If this accumulation is not removed, it will clog up the water passage and considerably reduce the efficiency of the cooling system.

- Drain the cooling system.
- Fill the cooling system with fresh water mixed with a flushing compound.

CAUTION
Avoid the use of a flushing compound which is harmful to the aluminum engine and radiator. Carefully follow the instructions supplied by the manufacturer of the cleaning product.

- Warm up the engine, and run it at normal operating temperature for about ten minutes.
- Stop the engine, and drain the cooling system.
- Fill the system with fresh water.
- Warm up the engine and drain the system.
- Repeat the previous two steps once more.
- Fill the system with a permanent type coolant, and bleed the air from the system.

Disassembly and Assembly Precautions

- Prior to disassembly of cooling system parts (radiator, pump, sensor, etc), wait until the coolant cools down, and then drain the coolant.
- After assembling and filling the system with a coolant, purge any air from the system.

3-10 COOLING SYSTEM

Water Pump

Water Pump Removal

- Remove:
 - Muffler (see Muffler Assembly Removal)
- Loosen the hose clamp (A) and disconnect the radiator hose (B) at the coolant inlet port of the water pump (C).
- Loosen the tube clamp (D), and pull off the coolant by-pass tube (E).
- Unscrew the water pump mounting bolts, and remove the water pump assembly.

NOTE

○ Note the position of different length of bolts so they can be installed in their original positions.

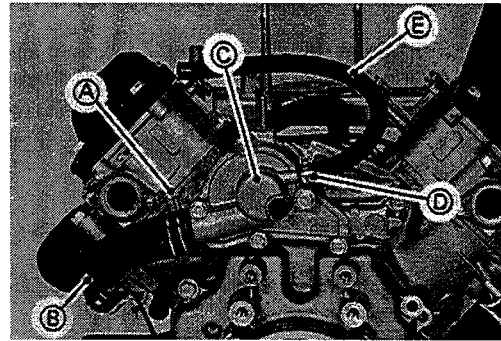

Installation Notes

- Chip the old gasket off the mating surfaces of the casecover and pump housing.
- Put a new gasket on the pump housing.
- Be sure to suitable set the pump gear to be meshed with the cam gear when installing the pump assembly. Do not force the pump into position.
- Install the mounting bolts and tighten them to the specification (see Torque Table).
- Note the position of different length of bolts.

Bolt Dimensions

- A. Bolt M6 l = 75 mm (2.95 in)
- B. Bolt M6 l = 65 mm (2.56 in)
- C. Bolt M8 l = 70 mm (2.76 in)
- D. Bolt M6 l = 45 mm (1.77 in)

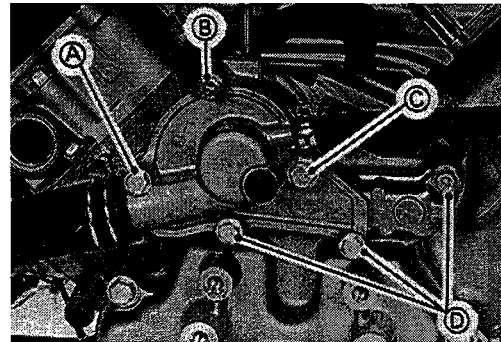

Disassembly

For disassembly, follow the steps (A ~ J) below (see Illustration).

NOTE

○ Do not attempt to remove the mechanical seal, oil seal and O-ring unless they are to be replaced.

- A. Plastic pump gear (1)
- B. Dowel pin (2)
- C. Claw washer (3)
- D. Extract the impeller subassembly (12)(11)(10)(9)(8)(7) from the pump housing (13).
- E. Mechanical seal cartridge (6)
- F. Oil seal (4)
- G. Dowel pin (11)
- H. Impeller (12)
- I. Mating ring (7) and cup-gasket (8)
- J. O-ring (10)

- | | |
|----------------------------|-------------------|
| 1. Pump Gear | 8. Cup Gasket |
| 2. Dowel Pin (1) | 9. Pump Shaft |
| 3. Claw Washer | 10. O-Ring |
| 4. Oil Seal | 11. Dowel Pin (2) |
| 5. Drainage outlet passage | 12. Impeller |
| 6. Cartridge | 13. Pump Housing |
| 7. Mating Ring | |

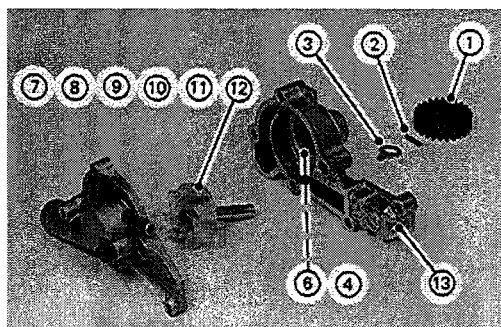
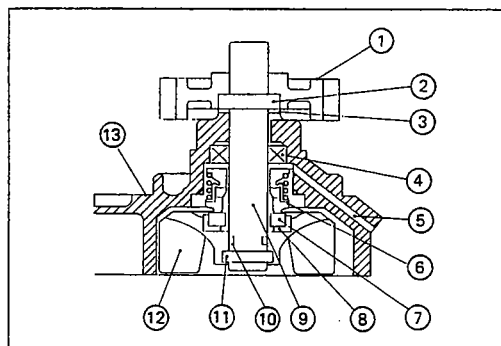

Internal Parts – Mechanical Seal

1. Mating Ring (Floating Seat)
2. Cup Gasket (Chusion Ring)
3. Seal Ring
4. Bellows
5. Spring Retainer
6. Coil Spring
7. Casing
8. Cartridge

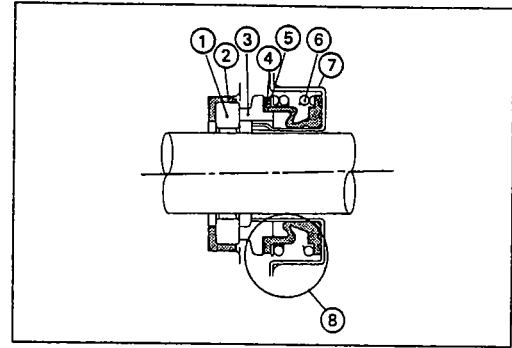

Pump Parts Inspection

- Clean All parts except plastic and rubber parts in a bath of high flash-point solvent and dry them with compressed air. Clean non-metal parts with detergent and water, and dry them.
- Inspect the pump housing for damage. Mating surfaces should be smooth and free of burrs and nicks. Replace the gasket if necessary.
- Check the other parts for wear or damage, replace the parts if necessary.
- ★ If the mechanical seal is damaged, the coolant leaks through the seal, and drain through the drainage outlet passage.
- ★ If the oil seal is damaged, the engine oil drain through the drainage passage.
- ★ If the mechanical seal parts are damaged, replace the seal as a set.
- Visually check the impeller.
- ★ If the surface is corroded, or if the blades are damaged, replace all internal pump parts.

- Measure the outside diameter (B) of the impeller shaft (A) end with a micrometer at several points.
- ★ If the shaft end diameter is less than service limit, replace the shaft.

Outside Diameter of Impeller Shaft End
Service Limit: 9.935 mm (0.3911 in)

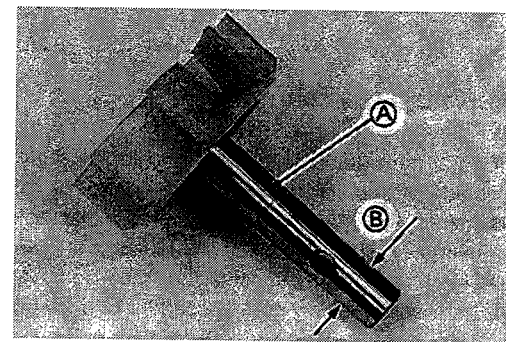

Assembly Notes

- When installing the mating ring (1) into the cup gasket (2), moisten outside surface of the mating ring with fresh water and then push the ring into the stop end. Do not damage mating surfaces.
- Pack some amount of high temperature grease into the oil seal (3). Press in the oil seal using a suitable tools so that the oil seal is flush with the shoulder surface.

NOTE

- The oil seal must be assembled with spring loaded lip toward inside of the engine.

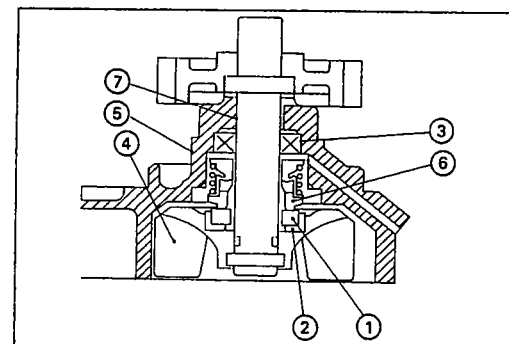

3-12 COOLING SYSTEM

- When installing the impeller (4) sub assembly to the housing (5), coat mating surfaces between the mating ring and seal ring (6) with a clean water.
- To avoid oil seal damage, coat thin film of engine oil on the pump shaft (7), and then carefully insert pump shaft into the housing.

Radiator

Removal

⚠ WARNING

Always allow the engine to cool before removing the radiator cap. Then remove the cap slowly and carefully to avoid a possible fast discharge of hot coolant which could cause severe burns.

- Remove the radiator cap and drain the coolant in the radiator (A) (see Coolant Draining).
- Loosen the hose clamps (B), and disconnect the radiator hoses (C) at the coolant inlet and outlet of the radiator.
- Unscrew the radiator mounting bolts (D), and remove the distance collars (E).
- Carefully remove the radiator with cooling air duct (F) to avoid damaging the fan blades.

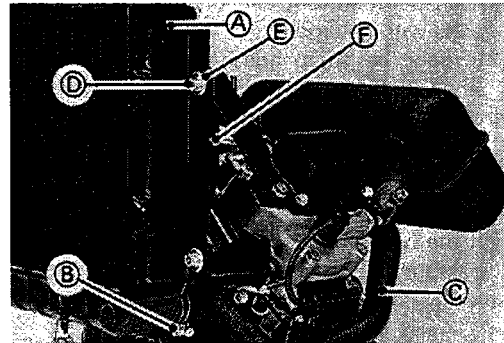

Radiator Inspection

- Check the radiator core.
- ★ If the corrugated fins are deformed, carefully straighten them with the blade of thin screw driver (A).
- Inspect the inlet and outlet tubes for cracks, kinks, dents, and fractured seams. Repair or replace the radiator, if necessary.
- Check for dirt and insects that may be lodged in the radiator. Clean them out by using compressed air or a low-pressure washer.

CAUTION

Using high-pressure water, as from a car wash facility, could damage the radiator fins and impair the radiator's effectiveness.

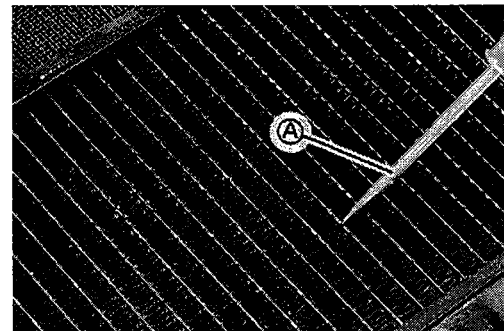

● If the air passages of the radiator core are blocked more than 30% by unremoval obstructions or irreparably deformed fins, replace the radiator with a new one.

★ If a radiator leak is detected, but cannot be spotted visually, test it as follows:

1. Install the radiator cap, and plug the overflow tube (3) and inlet pipe (1). Attach an air hose (4) to the outlet connection (2).
2. Pressurize the inside of the radiator with compressed air to about 50 to 70 kpa (7 to 10 psi).
3. Submerge the radiator in water and look for bubbles (5) which indicate the location of the leak.
4. Repair any leaks or replace it with a new one.

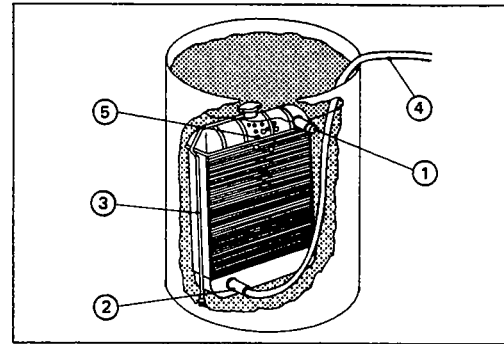

- Check the radiator filler neck for signs of damage.
- Check the condition of the top (A) and bottom (B) sealing seats in the filler neck. They must be smooth and clean for the radiator cap to function properly.

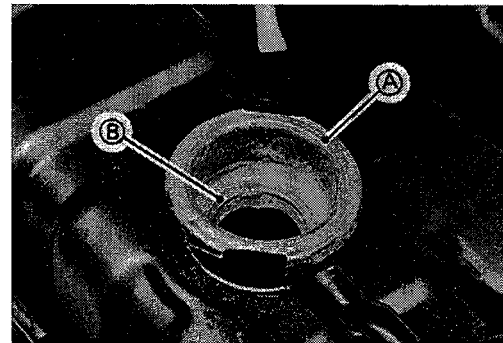

Radiator Cap Inspection

The radiator cap has two functions:

1. Allow atmospheric pressure to enter the cooling system.
 2. Prevents coolant escape at normal operating pressure.
- A pressure valve (D) in the cap permits the escape of coolant or steam when the pressure in the system rises above the relief pressure.
- A vacuum valve (E) in the cap opens when needed to prevent a vacuum in the cooling system.

● Check the condition of the valve spring (A), and the top (B) and bottom (C) valve seats of the radiator cap.

★ If any one of them shows visible damage, replace the cap.

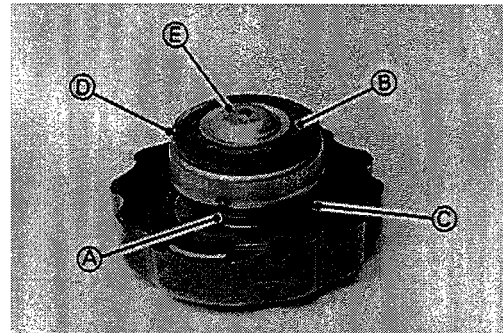

- Wet the radiator cap (B) sealing surfaces with water or coolant to prevent pressure leaks.
- Install the cap on a cooling system pressure tester (A).
- Watching the pressure gauge, pump the pressure tester to build up the pressure. The cap must retain the pressure at least 6 seconds. Also the cap must open at the pressure shown in the table.

Radiator Cap Relief Pressure

Pressure Valve: 78.2 to 97.8 kPa (11.4 to 14.2 psi)

Vacuum Valve: 4.90 kPa (0.71 psi) (vacuum)

★ If the cap cannot hold the specified pressure, or if it holds too much pressure, replace it with a new one.



3-14 COOLING SYSTEM

Radiator Hose Inspection

- In accordance with the Periodic Maintenance Chart, visually inspect the hoses (A) for signs of deterioration. Squeeze the hose. A hose should not be hard and brittle, nor should it be soft or swollen.
- Replace any damaged hose.

NOTE

- Hoses can deteriorate on the inside and still appear to be in good condition on the outside.

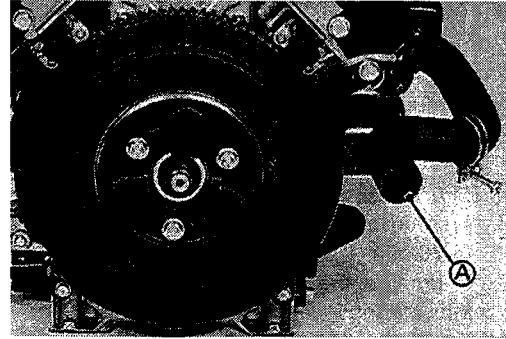

Radiator Hose Installation Notes

- Install the radiator hoses being careful to follow bending direction (see Exploded View). Avoid sharp bending, kinking, flattening, or twisting.

NOTE

- Locate the hose clamps (A) properly over the connections. A pressurized cooling system will blow a hose that is not installed properly. Tighten the hose clamps securely.

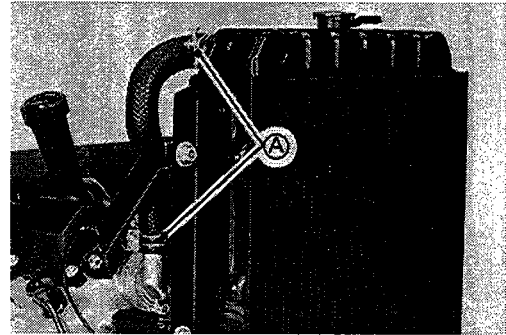

Cooling Fan, Fan Belt

The only service on the cooling fan is to be sure the fan blades are not deformed, and the blade tips are far enough from the air duct to not strike the duct.

The fan belt should be neither too tight nor too loose.

Belt Tension Check

- Remove:
 - Radiator (see Radiator Removal)
- Measure the belt tension using a proper belt tension gauges (1). Follow the manufacturer's instructions for use of the belt tension gauge. The belt tension is adjusted between 25 kg (55 lb) and 40 kg (88 lb) in the factory for the manufacturing standard.
- ★ If the belt tension is less than specified limit, adjust or replace the belt (2).

Belt Tension Service Limit
18 kg (40 lb)

- ★ If the belt tension gauge is not available, push (3) the belt with a thumb strongly at the middle between sheaves (1)(2). The slack (4) of the belt correspond the measurements of the belt tension gauge are as follow. Use the table as a guide line.

Belt Tension Measurements	Slacks
25 kg (55 lb)	12 mm (0.47 in)
40 kg (88 lb)	9 mm (0.35 in)
18 kg (40 lb)	17 mm (0.67 in)

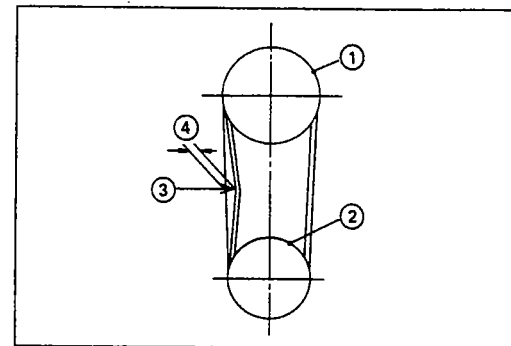
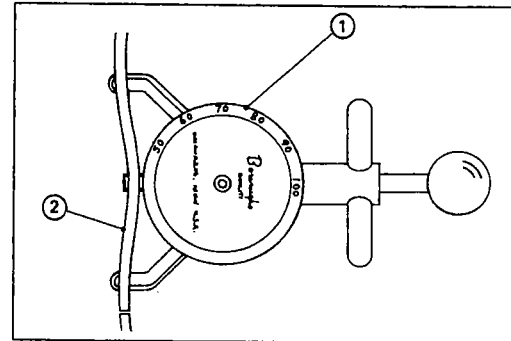

Belt Replacement Notes

- When replacing the fan belt, use only factory recommended belt with the proper length. To compensate for the belt length allowance, select appropriately sized shim(s) (A) from the table to obtain proper level of the belt tension (25 ~ 40 kg).

Fan Belt		A	B	C	D
No of shim	92180-2013*	1	2	1	2
	t = 0.6 mm				
	92180-2014*	-	-	1	1
	t = 1.2 mm				

* Part Number
t = Thickness of shim

A Belt: Smaller allowance
D Belt: Bigger allowance

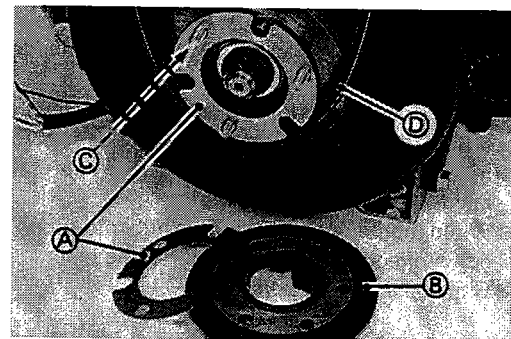

NOTE

- When tightening the sheave/hub (B) mounting nuts (C), rotate the fan in either direction to avoid pinching the belt (D).

Drive Belt Specification

MITSUBOSHI - 59011-2056

3-16 COOLING SYSTEM

Removal

- Remove:
 - Radiator (see Radiator Removal)
- Remove the radiator brackets (E).
- Disconnect the wire tie (D) which binding the pressure switch, pulser coil and primary ignition coil leads to the radiator bracket (E).
- Disconnect the thermo switch (A) lead and coolant bypass tube (B).
- Remove the thermo switch.
- Unscrew the bracket mounting bolts (C) and nuts (F), then remove the radiator mounting brackets.

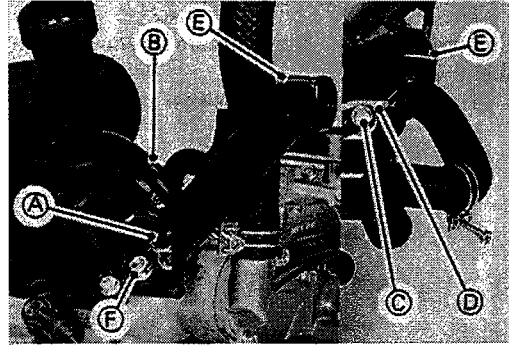

- Hold the fan drive sheave/hub (A) with a suitable spanner (D) to prevent rotating the sheave/hub.
- Unscrew the sheave/hub mounting nuts (B), and take off the sheave/hub and shims (C).
- Remove the fan belt rolling over the fan sheave.

NOTE

- When removing the fan belt, note the belt so that it may be reinstalled on the sheaves to rotate same direction as original installation.

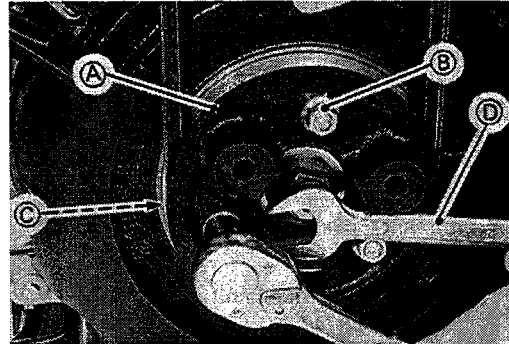

- Unscrew the mounting bolts (A), and take off the cooling fan (C) and fan sheave (B).

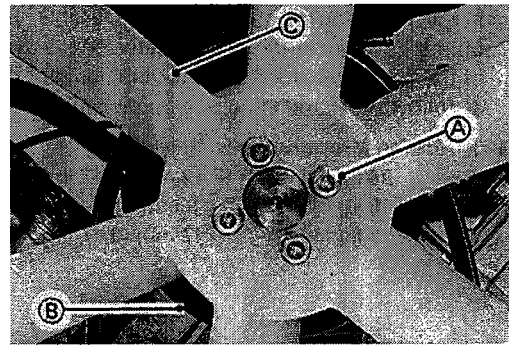

Installation Notes

- Install the cooling fan as "AISHIN" raised lettering (A) on the fan boss facing toward the radiator.
- Clean the drive belt by wiping with a clean cloth. Immediately wipe off any spilled oil or grease. Do not use solvent.
- Install the belt on the sheave to rotate same direction as original installation.
- When tightening the sheave/hub mounting nuts, rotate the fan in either direction to avoid pinching the belt.
- Check the belt tension.

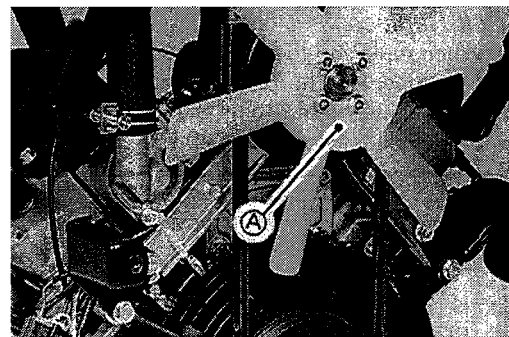

Inspection

- Be sure the fan blades are straight. Deformed blades reduce the cooling system efficiency and throw the fan out of balance.
- Check for excessive side wall wear of the sheaves and belt, replace if necessary. The belt and sides of the sheaves should wear evenly.
- Check to be sure dirt has not lodged and packed in the sheave V-grooves.
- Check the belt for swells or lumps, replace if necessary.

Fan Bearing Removal

- Remove:
 - Fan Mounting Bracket (4)
- Unscrew the fan shaft nut (1), and remove the shaft (3) and washer (2).
- To check the ball bearing (5), rotate the bearing slowly by finger; if any roughness is noted, the bearing should be replaced.

⚠ WARNING

Do not allow a flame or heating element to come in direct contact with the oil. Heat the oil in a well-ventilated area. Plan a safe handling procedure to avoid burns.

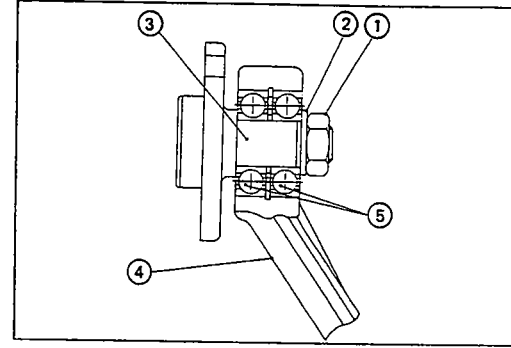

- To remove the ball bearing, heat the bearing housing in a hot 150°C (302°F) oil.
- Use a heat shield gloves to prevent burns.
- Place the bearing housing on a bench with bearing side up and take off the bearing with a suitable tools.

CAUTION

Do not remove the bearing unless it is necessary. Once it has been removed, it must be replaced.

Fan Bearing Installation Notes

- Coat the bearing surfaces with a light film of engine oil.
- Use a bearing driver, press in the fan side bearing flush with the housing (1).
- Install opposite side of bearing using a bearing driver until it stops at the stop [spacer(2)] in hole.
- Install the fan shaft (6), washer (5) and nut (4), then tighten the nut to the specified torque (see Exploded View).

- | | |
|------------|--------------|
| 1. Housing | 4. Nut |
| 2. Spacer | 5. Washer |
| 3. Circlip | 6. Fan Shaft |

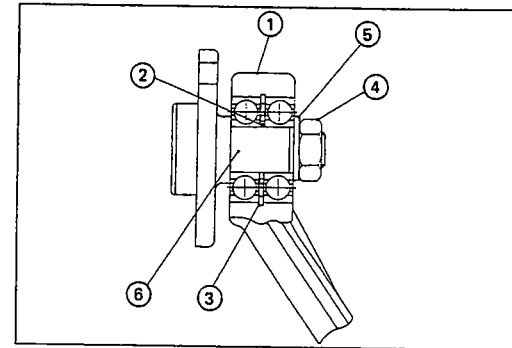

3-18 COOLING SYSTEM

Thermostat

This cooling system is equipped with a thermostat to maintain a optimum operating temperature. Coolant bypasses the closed thermostat when cold until operating temperature is attained.

Thermostat Removal

- Remove
 - Radiator (see Radiator Removal)
 - Cooling Fan (see Cooling Fan Removal)
- Loosen the hose clamp (A) and disconnect the radiator hose (B) at the thermostat cover.
- Unscrew the thermostat cover bolts (C), and remove the cover.
- Take off the thermostat (D).

NOTE

- With the thermostat installed, the jiggle valve may be positioned up-side of the thermostat when installing.

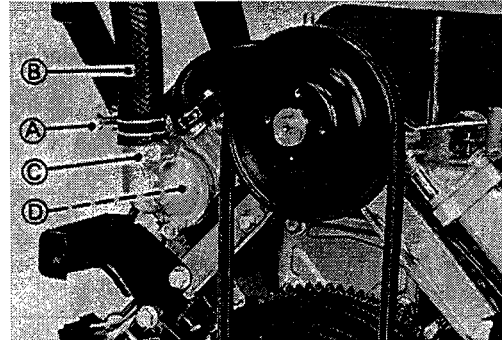

Thermostat Inspection

- Remove the thermostat, and check the jiggle valve (A) for sticking or binding on the flange (B) due to accumulation of a rust, scale or lime. Clean up the valve to ensure free movement of the valve (C), if necessary.

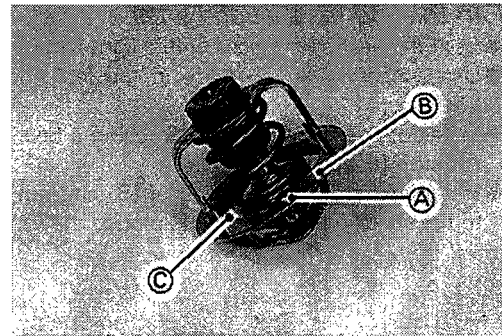

- Inspect the thermostat valve (1) at room temperature.
- ★ If the valve is open, replace the valve with a new one.
- To check valve opening temperature, suspend the thermostat and an accurate thermometer (2) in a container filled with a water.
- Place the container over a source of heat and gradually raise the temperature of the water while stirring the water gently.
- Watch the valve. The valve should begin to open at the temperature specified.
- It should be fully opened to 7mm (0.28 in) or more at the temperature specified.

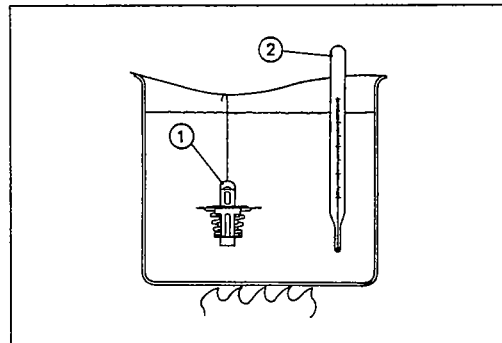

Thermostat Valve Specification

Begin Opening	80.5 to 83.5°C (177 to 182°F)
Full Open	95°C (203°F)

- The thermostat and thermometer must not touch the container sides.
- ★ If the thermostat fails any of these check, replace it.

Thermo Switch

When coolant temperature rises above 111°C (232°F), the thermo switch detects this and turns on a warning light on dash. Whenever you start the engine, make sure the warning light is not on in started engine.

If the warning light comes on, stop the engine immediately, and check the cooling system for over heating. Over heating can caused by:

- Lack of coolant
- Loose or slipping fan belt
- Clogging of cooling system
- Malfunction water pump or thermostat

Check the coolant level and temperature frequently.

Thermo Switch Removal and Installation Notes

- Drain the coolant (see Coolant Draining).
- Disconnect switch lead terminal (A).
- Loosen the bypass tube clamp (C) and disconnect the tube (B).
- Unscrew the thermo switch and remove it.
- When installing the thermo switch (D), apply a non-permanent locking agent to the threads and tighten the switch to the specified torque (see Exploded View).

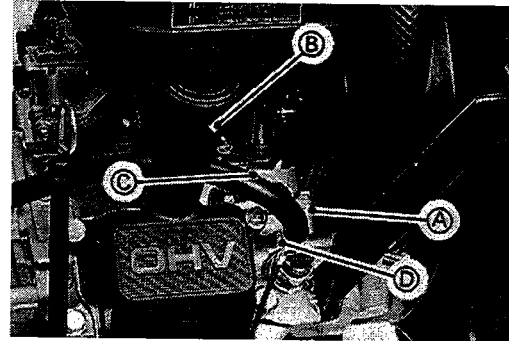

thermo Switch Inspection

- Using a ohmmeter, check to see that only the connections in the table have continuity.
- ★ If the switch has an open or short, repair it or replaced it with a new one.

Thermo Switch Connections

- **Rising temperature:**
From Off to On at 108 – 114°C (226 – 237°F)
- **Falling temperature:**
From On to FF at 101 – 107°C (214 – 225°F)
ON: Continuity
OFF: Infnit

- Suspend the switch (2) in a container of coolant (3) so that the temperature sensing projection and threaded portion are submerged.
- Suspend an accurate thermometer (1) in the coolant.

NOTE

- The switch and thermometer must not touch the container sides or bottom.
- Place the container over a source of heat (4) and gradually raise the temperature of the coolant while stirring the coolant gently.

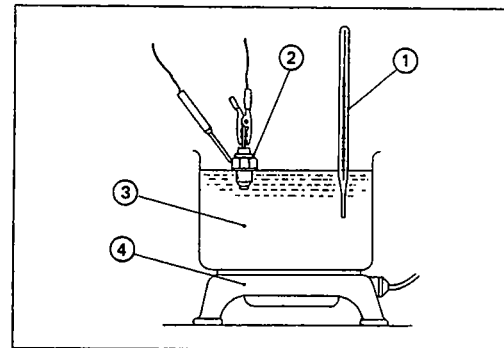

For Kawasaki Discount Parts Call 606-678-9623 or 606-561-4983

Engine Top End

Table of Contents

Exploded View	4-2
Specifications	4-4
Special Tools	4-5
Cylinder Head	4-6
Compression Measurement	4-6
Cylinder Head Assembly Removal	4-6
Installation Notes	4-7
Push Rod Installation Notes	4-8
Push Rod Inspection	4-8
Disassembly and Assembly	4-8
Cleaning and Inspection	4-9
Valves	4-11
Clearance Inspection	4-11
Clearance Adjustment	4-11
Valve Seat Inspection	4-12
Valve Seat Repair	4-12
Valve Head Thickness	4-15
Valve Stem Run Out	4-15
Valve Stem Diameter	4-15
Valve Guide Inside Diameter	4-15
Valve Spring Inspection	4-15
Cylinder, Piston	4-16
Piston Removal	4-16
Piston Installation Notes	4-17
Piston/Cylinder Seizure	4-18
Piston Cleaning	4-18
Piston Ring and Ring Groove Wear	4-18
Piston Ring End Gap	4-19
Piston Pin, Piston Pin Hole, and Connecting Rod Wear	4-20
Piston Diameter	4-20
Cylinder Inside Diameter	4-20
Cylinder Boring and Honing	4-21
Muffler	4-23
Muffler Assembly Removal	4-23
Muffler Assembly Installation Notes	4-23
Inspection	4-23

4-2 ENGINE TOP END

Exploded View

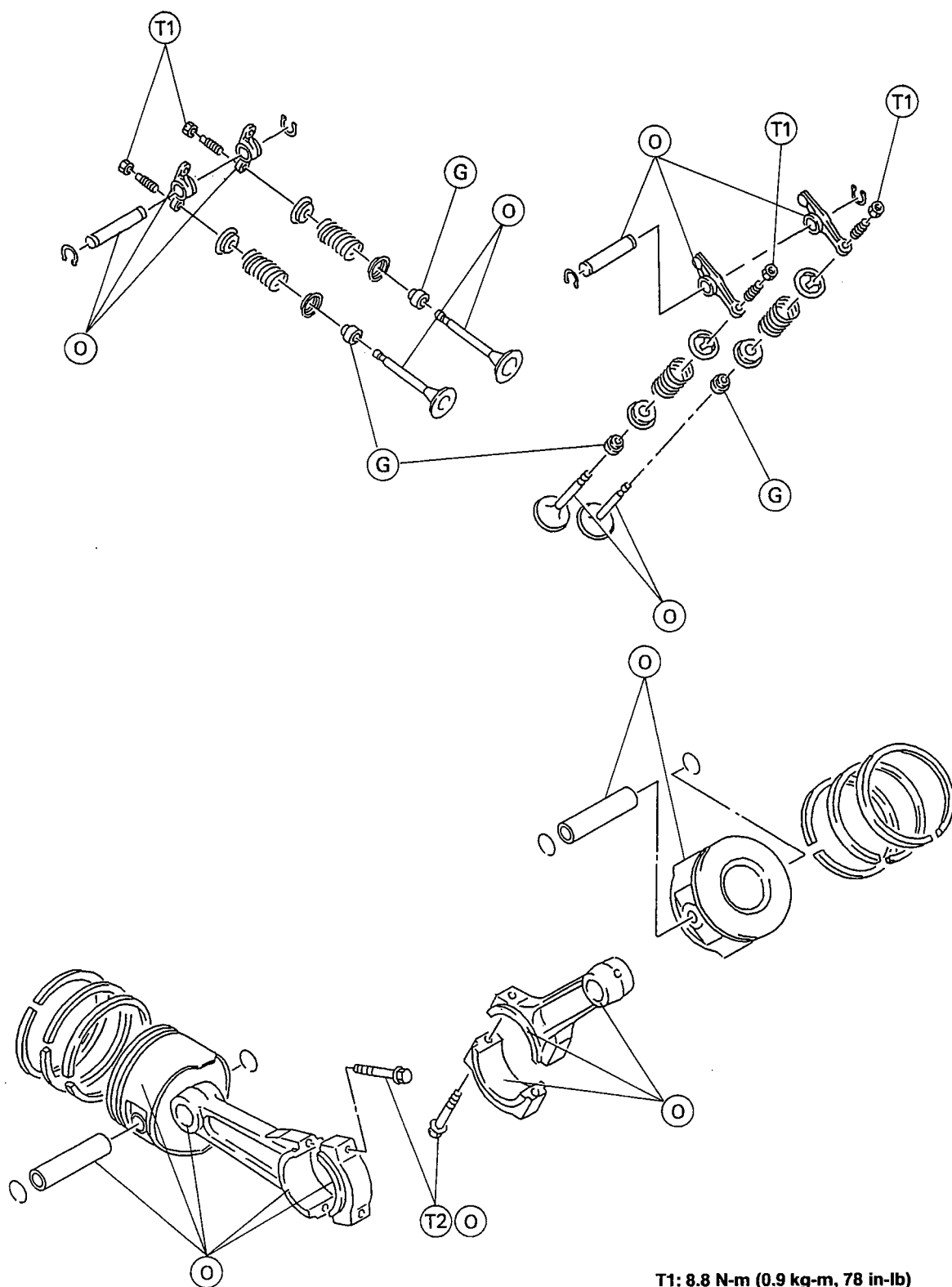

T1: 8.8 N-m (0.9 kg-m, 78 in-lb)
T2: 21.0 N-m (2.1 kg-m, 15 ft-lb)

O: Apply engine oil
G: Apply Grease

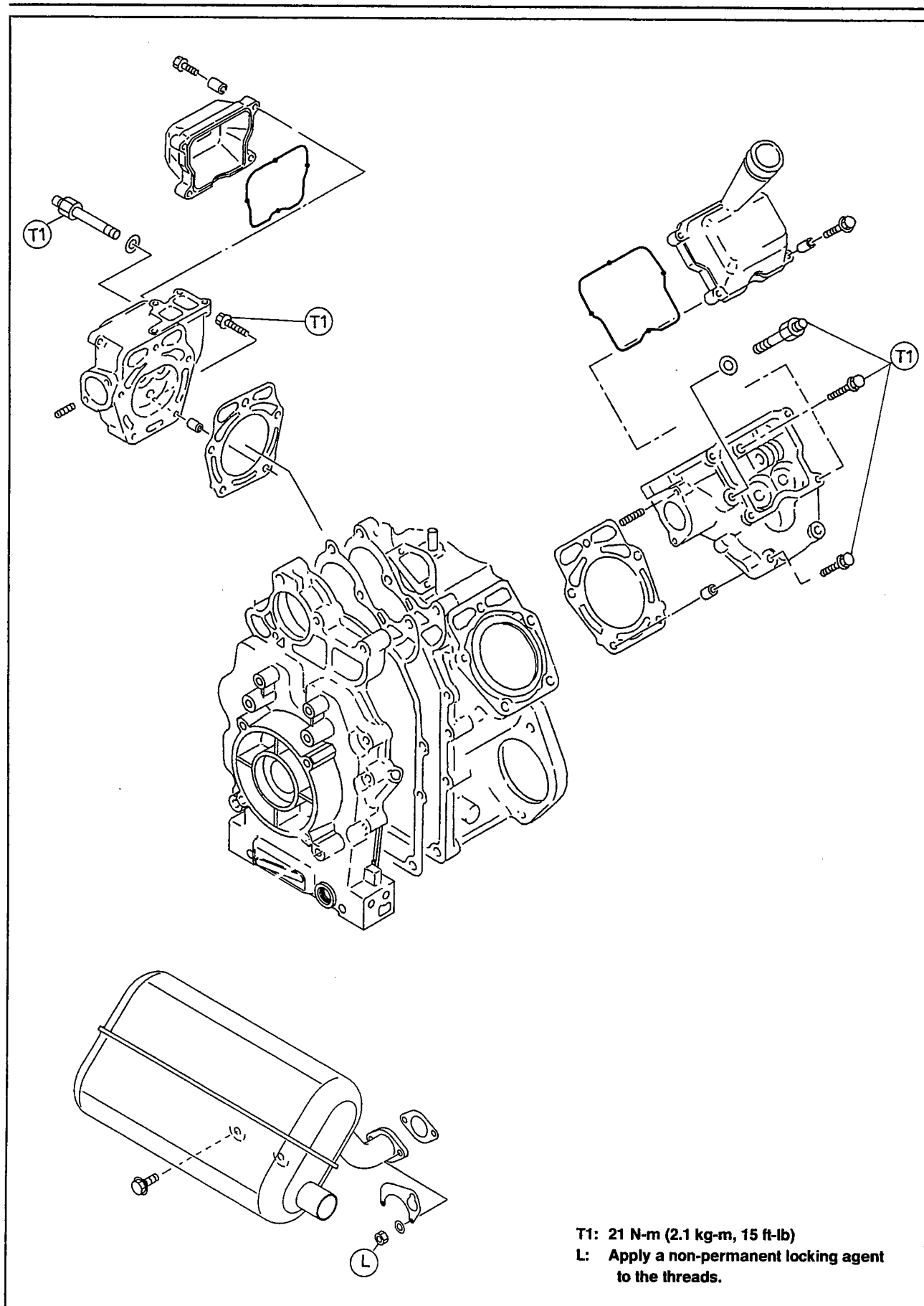

T1: 21 N-m (2.1 kg-m, 15 ft-lb)

L: Apply a non-permanent locking agent to the threads.

4-4 ENGINE TOP END

Specifications

Item		Service Limit
Cylinder Head:		
Cylinder compression (MIN)		[1171 kpa (170 psi)] (MIN)
Cylinder head warp		0.06 mm (0.002 in.)
Valves:		
Valve seating surface width	Intake, Exhaust	2.0 mm (0.08 in)
Valve head thickness	Intake, Exhaust	0.6 mm (0.024 in)
Valve stem run out	Intake, Exhaust	0.05mm (0.002 in)
Valve stem diameter	Intake	5.945 mm (0.2341 in)
	Exhaust	5.925 mm (0.2332 in)
Valve guide inside diameter	Intake	6.045 mm (0.2379 in)
	Exhaust	6.055 mm (0.2384 in)
Valve spring free length	Intake, Exhaust	29.70 mm (1.17 in)
Rocker arm push rod runout	Intake, Exhaust	0.80 mm (0.03 in)
Rocker shaft outside diameter	Intake, Exhaust	11.949 mm (0.4704 in)
Rocker arm bearing inside diameter	Intake, Exhaust	12.074 mm (0.4754 in)
Cylinder, Piston:		
Piston ring/groove clearance	Top	0.15 mm (0.006 in)
	Second	0.12 mm (0.005 in)
Piston ring thickness	Top, Second	1.12 mm (0.044 in)
Piston ring end gap	Top, Second	1.2 mm (0.05 in)
	Oil	1.5 mm (0.06 in)
Piston pin outside diameter		16.975 mm (0.6683 in)
Piston pin hole inside diameter		17.041 mm (0.6709 in)
Connecting rod small end inside diameter		17.051 mm (0.6713 in)
Cylinder inside diameter:	Standard Cylinder	76.067 mm (2.9948 in)
	0.25 mm Oversize	76.317 mm (3.0046 in)
	0.50 mm Oversize	76.567 mm (3.0144 in)
	0.75 mm Oversize	76.817 mm (3.0242 in)
Cylinder bore out of round		0.056 mm (0.0022 in)

Item		Standard
Valve Clearance	Intake, Exhaust	0.25 mm (0.01 in)
Valve Seating Surface Angle	Intake, Exhaust	45°
Valve Seating Surface Width	Intake, Exhaust	0.5 to 1.1 mm
		(0.02 to 0.043 in)
Valve Guide Inside Diameter	Intake, Exhaust	6.00 to 6.012 mm
		(0.2362 to 0.2367 in)
Cylinder Bore Diameter		
Standard cylinder		76.000 to 75.980 mm (2.9921 to 2.9913 in)
0.25 mm Over size		76.250 to 76.230 mm (3.0020 to 3.0012 in)
0.50 mm Over size		76.500 to 76.480 mm (3.0118 to 3.0110 in)
0.75 mm Over size		76.750 to 76.730 mm (3.0216 to 3.0209 in)

Special Tools

Compression Gauge Assembly, M14 x 1.25: 57001-123

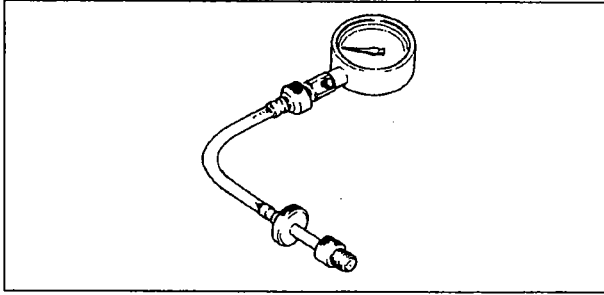

Valve Seat Cutter Holder, $\phi 6$: 57001-1360

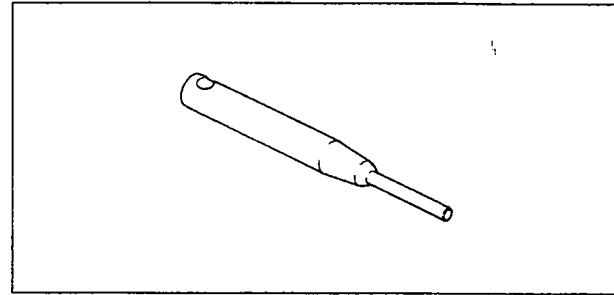

Piston Ring Pliers: 57001-115

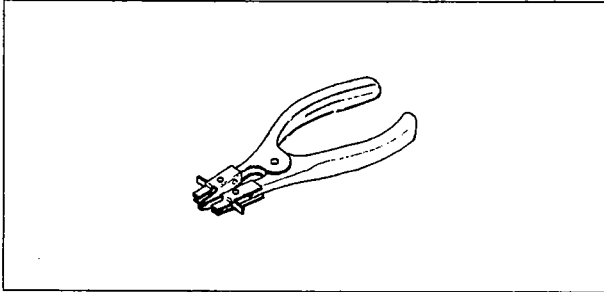

Valve Seat Cutter, 45° - $\phi 35$: 57001-1116

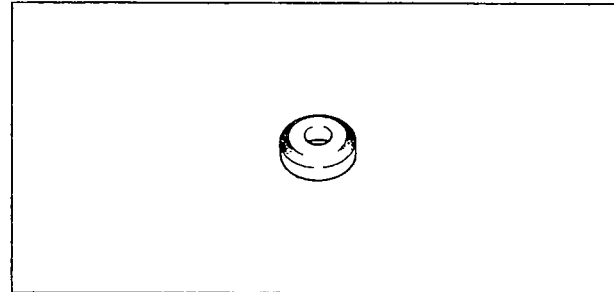

Piston Ring Compressor Grip: 57001-1095

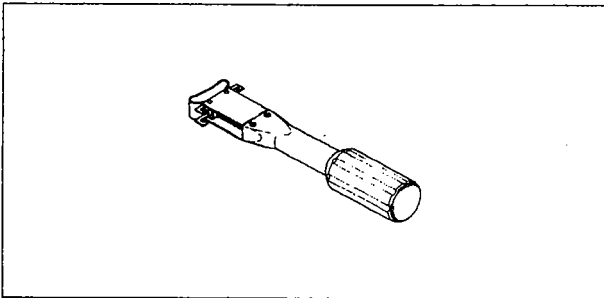

Valve Seat Cutter, 30° - $\phi 33$: 57001-1199

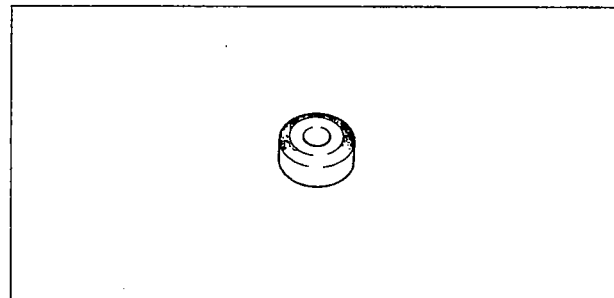

Piston Ring Compressor Belt, $\phi 67 \sim \phi 79$: 57001-1097

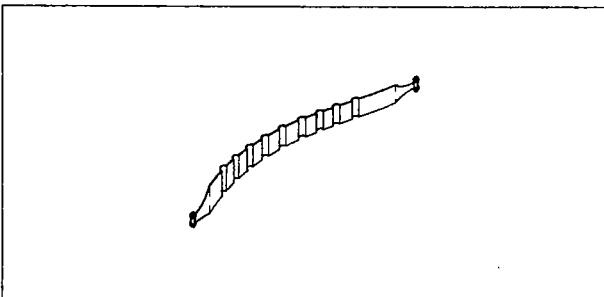

Valve Seat Cutter, 45° - $\phi 30$: 57001-1187

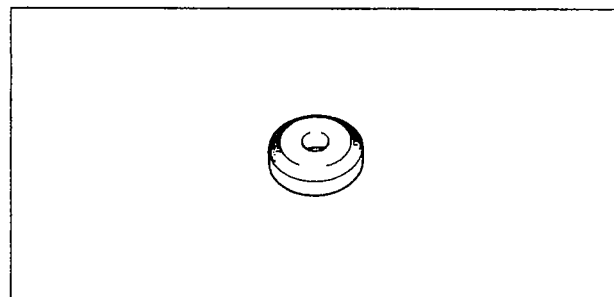

Valve Seat Cutter Holder Bar: 57001-1128

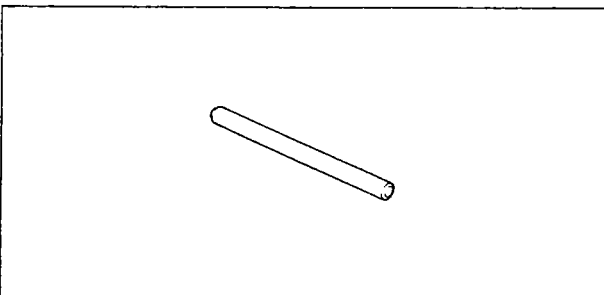

Valve Seat Cutter, 30° - $\phi 30$: 57001-1120

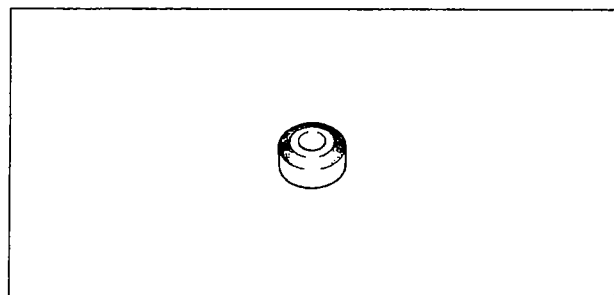

4-6 ENGINE TOP END

Cylinder Head

Compression Measurement

- Before measuring compression, do the following.
- Be sure the battery is fully charged.
- Thoroughly warm up the engine so that engine oil between the piston and cylinder wall will help seal compression as it does during normal running.
- Stop the engine.
- Disconnect the spark plug caps of each cylinder and remove the spark plugs.
- Attach the compression gauge assembly (A) (Special Tool: 57001-123) firmly into the one plug hole.
- Ground the spark plugs to the engine.

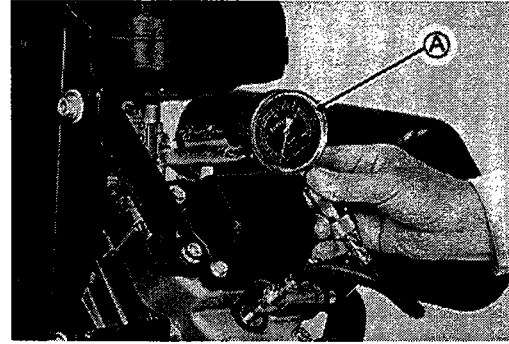

⚠ WARNING

To avoid fire, do not ground the spark plugs in closed positions to the plug holes. Keep the plugs as far away as possible from the plug holes.

- Using the starter motor, turn the engine over with the throttle fully open until the compression gauge stops rising; the compression reading obtainable.
- Repeat the measurement to the other cylinder.

Cylinder Compression (MIN) 1171 kPa (170 psi)

- ★ If the compression is higher than the specified value, the piston rings, cylinder and valves are probably in good condition.
- ★ If the compression is too high, check the following.
 - (1) Carbon build-up on the piston head and cylinder head - clean off any carbon on the piston head and cylinder head.
 - (2) Cylinder head gasket - use only the proper gasket. The use of a gasket of incorrect thickness will change the compression.
 - (3) Valve guides and piston rings - rapid carbon accumulation in the combustion chamber may be caused worn valve guides and/or worn piston oil rings. This may be indicated by white exhaust smoke.
- ★ If cylinder compression is lower than the (MIN), check the following:
 - (1) Gas leakage around the cylinder head - replace the damaged gasket and check the cylinder head warp.
 - (2) Condition of the valve seating.
 - (3) Valve clearance.
 - (4) Piston/cylinder wear, piston seizure.
 - (5) Piston ring, piston ring groove.

Cylinder Head Assembly Removal

- Remove:
 - Radiator and it's Bracket
 - Air Cleaner and Carburetor
 - Muffler
 - Intake Manifold
 - Thermostat (No. 2 Cylinder)
 - Spark Plug
- Unscrew the rocker cover mounting bolts, and remove the cover and gasket (o-ring). Do not lose the distance collars in the bolt holes.
 - A. Rocker Cover (No. 1 Cylinder)
 - B. Rocker Cover (No. 2 Cylinder)
 - C. Mounting Bolts
 - D. Collars

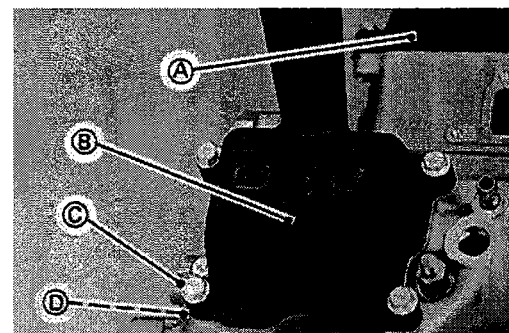

- Loosen the cylinder head bolts 1/4 turn in the sequence shown.

CAUTION

If the above procedure is not followed, the cylinder head may be warped during removal.

- Repeat the sequence until all bolts are removed and lift off the cylinder head assembly.

NOTE

- Mark the push-rods so they can be installed in their original position during assembly.
- Note the position of the special bolt (A) for reinstalling the cylinder head.

(No.2 Cyl. shown)

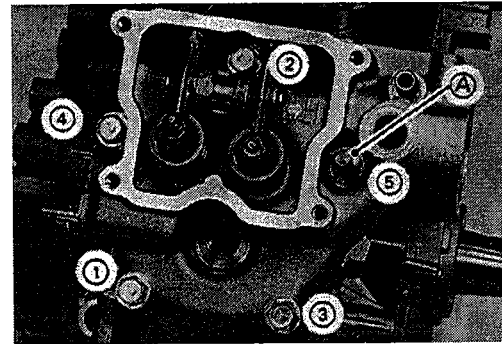

Installation Notes

- Clean the mating surfaces of the cylinder heads and cylinder.
- Install the push rods in their original positions on each cylinder. (see Push Rod Installation)
- Put a new gaskets and the cylinder head assemblies on each cylinder, then let the cylinder heads with push rods aligned under the rocker arms.

NOTE

○ As the head gaskets are coated with sealing agents, be carefull not to injure the surface of them.

- Install the head bolts noting the position of special bolts (A) and tighten them temporarily.

(No.1 Cyl. shown)

- Install the intake minifold onto cylinder heads. (see Intake Manifold Installation Note)
- Then tighten the head bolts to the specification (see Exploded View).
- Follow the sequence shown, tighten the head bolts to 21 N-m (15 ft-lb).
- Tighten the bolts in sequence 3.0 N-m (27 in-lb) at a time until torque on each bolt is 21 N-m (15 ft-lb).

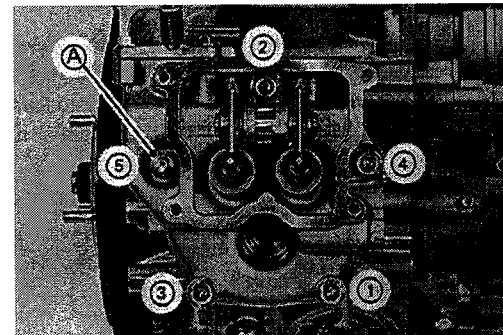

CAUTION

A torque wrench must be used to prevent loose or overtight the head bolts which may result in warping of the cylinder head.

Push Rod Installation Notes

● Align (R) mark on the flywheel (1) with (▲) mark on the breather chamber cover (2) turning the flywheel clockwise.

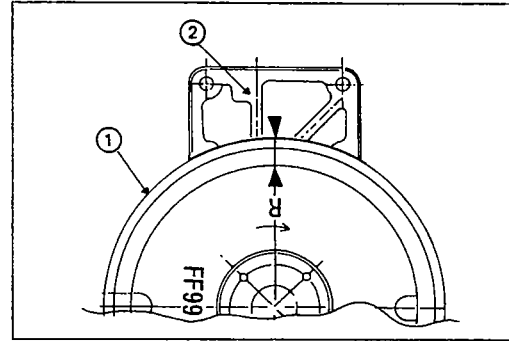

- Install the push rods in their original positions on each cylinder.
- To install the push rod in a correct position on the tappet, insert the push rod so end of the push rod is sliding down along inside wall of the crankcase and position the push rod end on to the tappet.
- Check both intake and exhaust push rods on each cylinder are lowest position on the cam lobes, if not turn the flywheel clockwise one turn (360°) and align both marks on the flywheel and breather chamber cover again.
- Be sure the end of the push rods are correctly seated on the tappets.

- | | |
|---------------------|-----------------|
| 1. Push Rods | 4. Inside Walls |
| 2. Tappets | 5. Sliding Down |
| 3. Lowest Cam Lobes | |

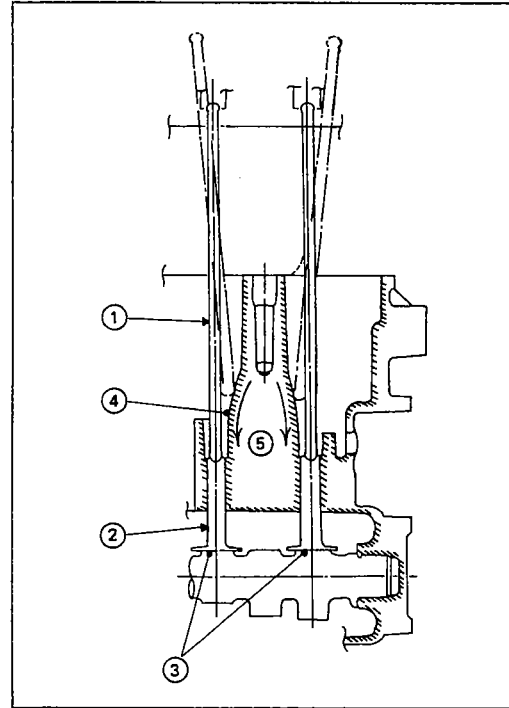

Push Rod Inspection

● Place the rocker arm push rod in V blocks that are as far apart as possible, and set a dial gauge on the rod at a point halfway between the blocks. Turn the rod to measure the runout. The difference between highest and the lowest dial readings is the amount of runout.

★ If the runout exceeds the service limit, replace the rod.

Rocker Arm Push Rod Runout
Service Limit: 0.8 mm (0.03 in)

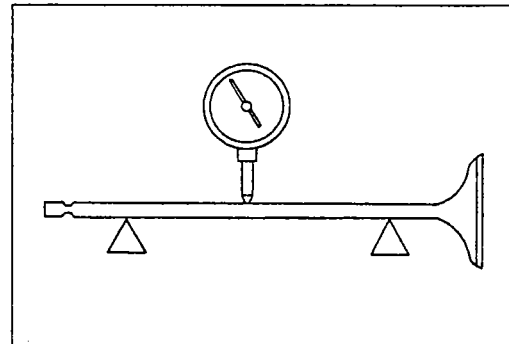

Disassembly and Assembly

(Valve Mechanism Removal and Installation)

NOTE

○ When removing the valve mechanism parts, note the position of them so that they may be reinstalled in their original position during assembly.

- Remove one of the rockershaft circlip (A) with a circlip pliers.
- Remove the rocker arms (B) by pushing the rocker shaft (C) out the side from which the circlip was removed.

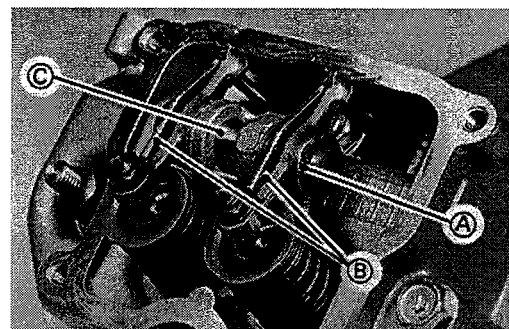

- Support the valve head in the combustion chamber with a suitable block.
- To remove the spring retainer (A), push down the retainer with thumbs and shift (C) the retainer to a side hole (B) on the retainer.
- Remove the spring and valve.

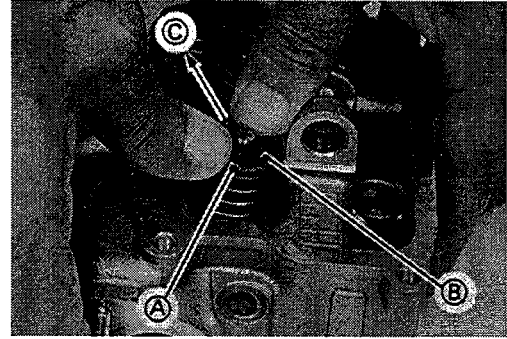

- Remove the stem seals (A) and bottom spring retainers (C).

NOTE

- It is not necessary to remove the stem seal unless it is being replaced.
- Bottom spring retainer can only be removed with stem seal.
- Valve guide (B) is not replaceable, do not remove it.

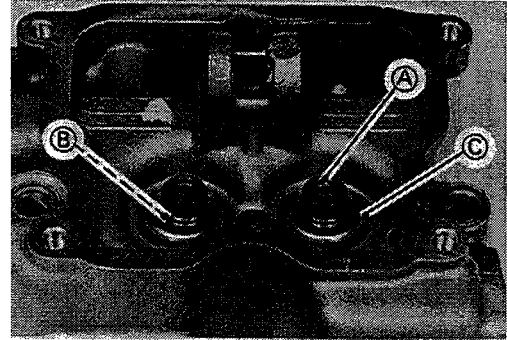

- Valve Installation
 - Apply engine oil to the valve stem to avoid damaging the stem seal.
 - Check to see that the valve moves smoothly up and down in the guide.
 - Check to see that the valve seats properly in the valve seat. If it does not, repair the valve seat.
- Rocker Arm Installation
 - Apply engine oil to the bearing surface of rocker arm.
 - Put engine oil to the rocker arm where it touches the push rod and valve stem end.
 - Install the rocker arm.

Cleaning and Inspection

- Scrape the carbon deposits from the head and exhaust port with a suitable tool.
- To avoid gouging, use scrapers that are made of a material that will not cause damage.
- Clean the head in a bath of high flash-point solvent and dry it with compressed air.

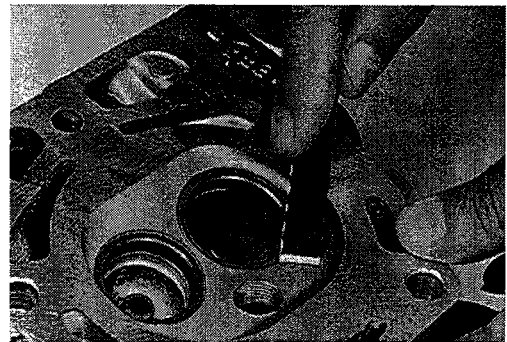

▲ WARNING

Clean the cylinder head in a well-ventilated area, and take care that there are no sparks or flame anywhere near the working area; this includes any appliance with a pilot light. Do not use gasoline or a low flash-point solvent to clean the cylinder head. A fire or explosion could result.

- Lay a straightedge (A) across the gasket surface of the head at several different points, and measure warp by inserting a thickness gauge (B) between the straightedge and head.
- ★ If warp exceeds the service limit, repair the gasket surface. Replace the cylinder head if the mating surface is badly damaged.

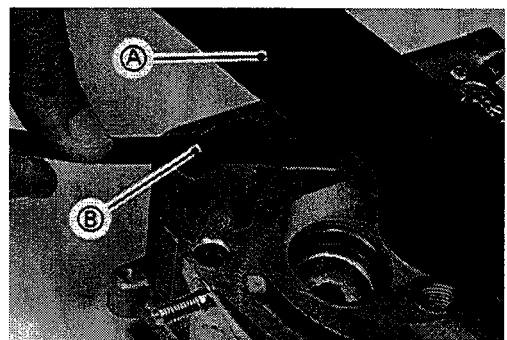

Cylinder Head Warp

Service Limit: 0.06 mm (0.002 in)

4-10 ENGINE TOP END

- Check the cylinder head for cracks or other damage.
- Cracks not visible to the eye may be detected by coating the suspected area with mixture of 25% kerosene and 75% light engine oil.
- Wipe the area dry and immediately apply a coating of zinc oxide dissolved in wood alcohol. If a crack is present, the coating will become discolored at the defective area.
- ★ If a crack is present in the cylinder head, replace it.
- Inspect the gasket surface for burrs and nicks.

- Inspect the cylinder head for accumulation of rust, scale and lime in the water jacket (A).
- ★ If this accumulation is observed, flush the cooling system (see Flushing in Cooling System chapter).

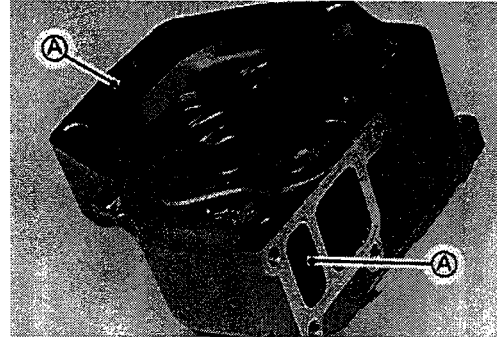

- Clean and measure the diameter of the rocker shaft (A) with a micrometer at several points.
- ★ If the outside diameter is less than the service limit, replace the shaft.

Rocker Shaft Outside Diameter

Service Limit: 11.949 mm (0.4704 in)

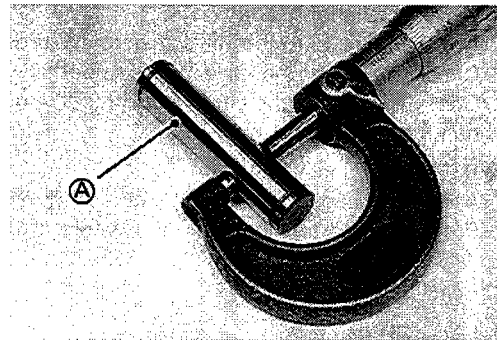

- Clean and inspect the rocker arm where it touches the push rod and valve stem.
- ★ If the contact points (A) are worn or damaged, replace the rocker arm.
- Measure the inside diameter of the rocker arm bearing (B) at several points using a dial bore gauge or inside micrometer.
- ★ If the inside diameter is more than the service limit, replace the rocker arm.

Rocker Arm Bearing Inside Diameter

Service Limit: 12.074 mm (0.4754 in)

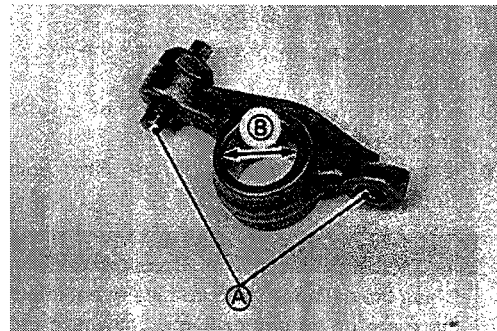

Valves

Clearance Inspection

NOTE

○ Valve clearance must be checked when the engine is cold (at room temperature).

- Remove the rocker chamber cover (see Cylinder Head Removal).
- Place the piston at top dead center (TDC) of the compression stroke turning the crankshaft clockwise facing the flywheel.

No. 1 Cylinder:

- Align (1) mark on the flywheel (1) with (▲) mark on the breather chamber cover (2) as shown.
- Check the intake and exhaust valves are closed completely, if not turn the flywheel one turn (360°) clockwise and align both marks on the flywheel and cover again.

No. 2 Cylinder:

- Align (2) mark on the flywheel with (▲) mark on the breather chamber cover. Follow No. 1 Cylinder alignment procedure described above.
- Then check the clearance.
- Using a thickness gauge (A), measure the valve clearance between the rocker arm and the valve stem end.
- ★ If the valve clearance is incorrect, adjust it.

Valve Clearance (when cold)

Intake, Exhaust: 0.25 mm (0.01 in)

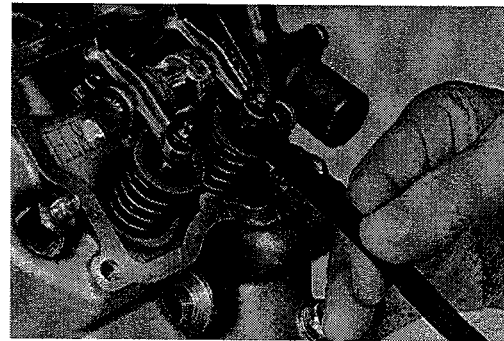
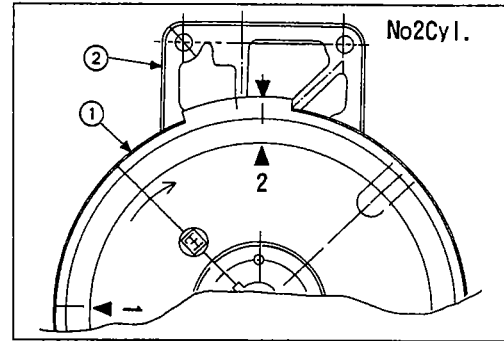
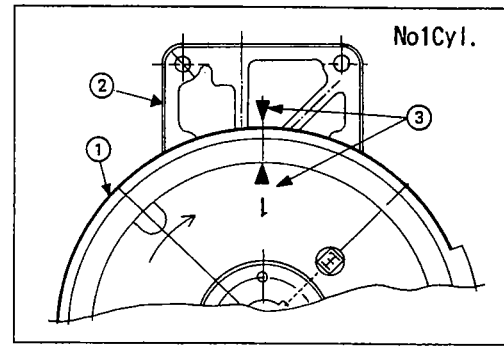

Clearance Adjustment

- Since the valve repairs change the valve clearance, adjust the valve clearance to the specification.
- Assemble the cylinder head and install the cylinder head assembly on the block (see cylinder Head Installation Notes).
- Turn the crankshaft proper direction until the piston is at TDC of the compression stroke (described above).
- Loosen the locknut (C) and valve clearance adjusting screws (B).
- Insert a 0.25 mm (0.01 in) thickness gauge (A) between the adjusting screw and valve stem, and tighten the adjusting screw until the thickness gauge begin to bind between the rocker arm and valve stem end. Use a sweeping motion with the thickness gauge while making this adjustment.
- Holding the adjusting screw with a spanner, tighten the locknut to the specified torque (see Exploded View).
- Do not overtighten.

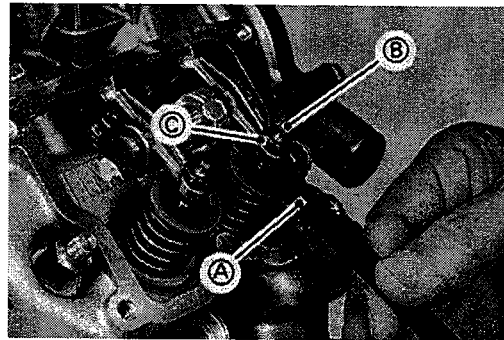

4-12 ENGINE TOP END

NOTE

○ For designing an adjustment tools, refer to the following dimensional specifications.

- 1: 8.80 to 9.00 mm (0.346 to 0.354 in)
- 2: 3.85 to 4.25 mm (0.15 to 0.17 in)
- 3: 2.80 to 3.00 mm (0.11 to 0.12 in)
- 4: 2.00 to 2.50 mm (0.08 to 0.10 in)
- 5: M5 P0.5 screw
- 6: Rocker Arm

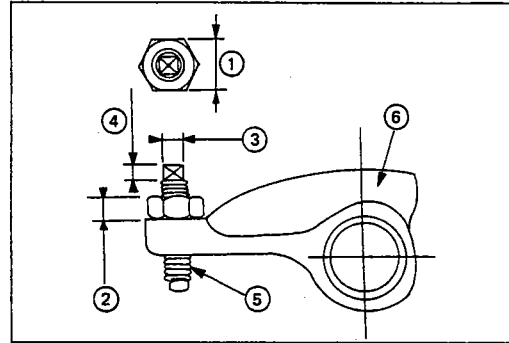

Valve Seat Inspection

- Remove the valve.
- Inspect the valve seats for damage.
- ★ If the seats are warped or distorted by beyond reconditioning, replace the cylinder head.
- Pitted or worn the valve seats can be refaced. Lap the valves to the seats after refacing.
- Coat the valve seat with machinist's dye.
- Push the valve into the guide.
- Rotate the valve against the seat with a lapping tool.
- Pull the valve out, and check the seating pattern on the valve head. It must be the correct width and even all the way around.

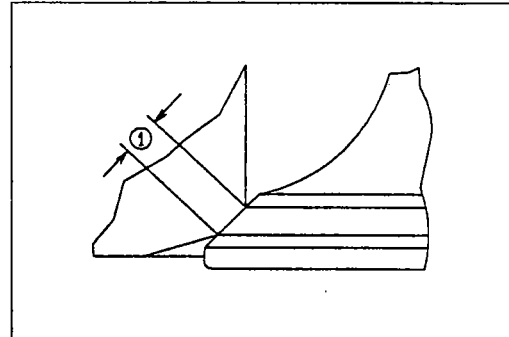

NOTE

○ The valve stem and guide must be in good condition or this check will not be valid.

★ If the valve seating pattern is not correct, repair the seat.

Valve Seating Surface Width (STD)

Inlet, Exhaust: 0.5 ~ 1.1 mm (0.02 ~ 0.043 in)

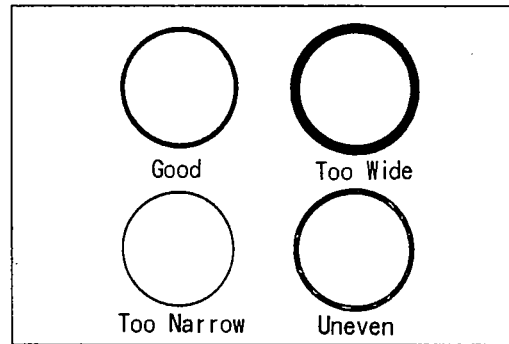

Valve Seat Repair

- Follow the manufacture's instructions for use of valve seat cutters (special tools).

Use these Cutters

Intake Valve

Seat Cutter	45° - ϕ 35.0	57001-1116
Outside Cutter	30° - ϕ 33.0	57001-1199

Exhaust Valve

Seat Cutter	45° - ϕ 30.0	57001-1187
Outside Cutter	30° - ϕ 30.0	57001-1120

Use this Holder and Bar

Holder - ϕ 6.0	57001-1360
Bar	57001-1128

★ If the manufacture's instructions are not available, use the following procedure.

Seat Cutter Operating Cares:

1. This valve seat cutter is designed only for valve seat repair. Therefore the cutter must not be used for other purposes.

2. Do not drop or hit the valve seat cutter, or the diamond particles may fall off.
3. Do not fail to apply engine oil to the valve seat cutter before grinding the seat surface. Also wash off ground particles sticking to the cutter with washing oil.

NOTE

○ Do not use a wire brush to remove the metal particles from the cutter. It will take off the diamond particles.

4. Setting the valve seat cutter holder in position, operate the cutter with one hand. Do not apply too much force to the diamond portion.

NOTE

○ Prior to grinding, apply oil to the cutter, and during the operation wash off any ground particles sticking to the cutter with washing oil.

1. Cutter
 2. Cutter Holder
 3. Bar
5. After use wash the cutter with washing oil and apply a thin layer of engine oil before storing.

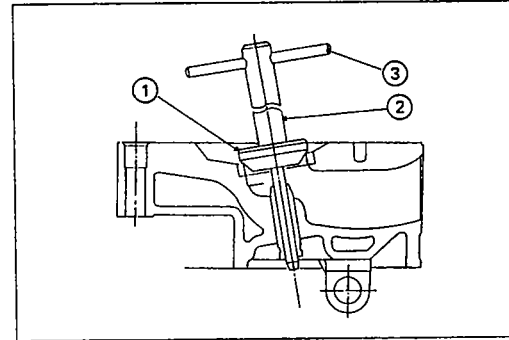

Marks Stamped on the Cutter:

The marks stamped on the back of the cutter represent the following.
 1Cutter number, selected from 1 to 12
 30°Cutter angle
 37.5Outer diameter of cutter
 KS8BManufactured lot number

1. Cutter Outside Diameter
2. Cutter Angle

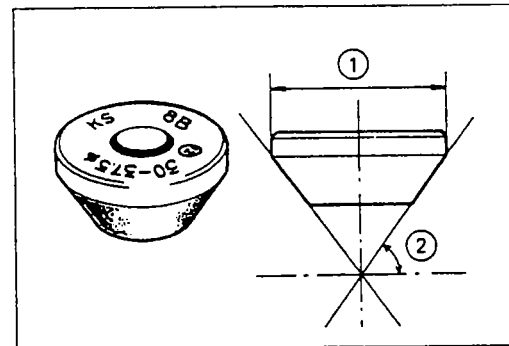

Operating Procedures:

- Clean the seat area carefully.
- Recondition the valve seats with the valve seat cutters (45°, 30°) and lap the valves.
- Check the seats for good contact all the way around with machinist's dye.
- Measure the seat width is more than 2.0 mm (0.08 in) the seating surface should be refaced.
- ★ If the valve seating pattern is not correct, repair the seat.

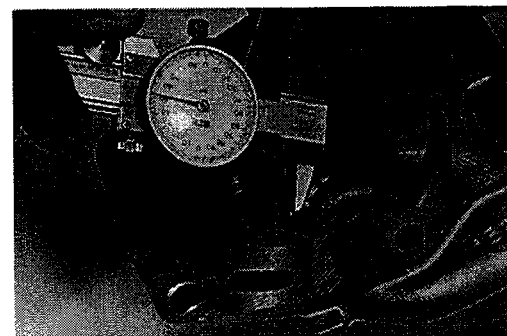

- Coat the seat with machinist's dye.
- Fit a 45 ° cutter (A) to the holder and slide it into the valve guide.
- Resurface the valve seat with a 45 ° cutter, removing only enough material to produce a smooth and concentric seat.

CAUTION

Do not grind the seat too much. Overgrinding will reduce valve clearance by sinking the valve into the head. If the valve sinks too far into the head, it will be impossible to adjust the clearance and the cylinder head must be replaced.
Do not turn the cutter counterclockwise or drop it against the seat, or it will be dulled.

- Use a 30 ° seat cutter (A) to narrow the seat width to the STD width.
- Turn the seat cutter one turn at a time while pressing down very lightly. Check the seat width after each turn.

CAUTION

The 30 ° cutter removes material very quickly. Check the seat width frequently to prevent over grinding.

NOTE

- *Keep the seat width as closely as possible to 0.8 mm (0.03 in).*
- Make a light pass with the 45° cutter to remove any possible burrs at the edge of the seat.
- After resurfacing the seat, inspect for even valve seating.
- Apply a machinist's dye to the valve face, insert the valve, and snap it closed against the seat several times. The valve surface should show good contact all the way around. Be sure the valve seat is centered on the valve face. The position of the valve in the seat is evident after lapping the valve.
- ★ If the seat does not make proper contact, lap the valve into seat with a vacuum cap tool (A).
- Coat the face of valve sparingly with a fine lapping compound.
- Use the vacuum cup tool, to grip top of the valve. Rotate the valve in a circular motion to lap the valve to the seat.
- Lift the valve slightly from the seat every 8 to 10 strokes, continue lapping operation until a uniform ring appears around entire surface of the valve face.

- When lapping is completed, wash all parts in solvent to remove lapping compound. Dry the parts thoroughly.
- Note the position of the lapping mark on the valve face. The lapping mark should appear on or near the center of the valve face.
- When the engine is assembled, be sure to adjust the valve clearances (see Valve Clearance Adjustment).

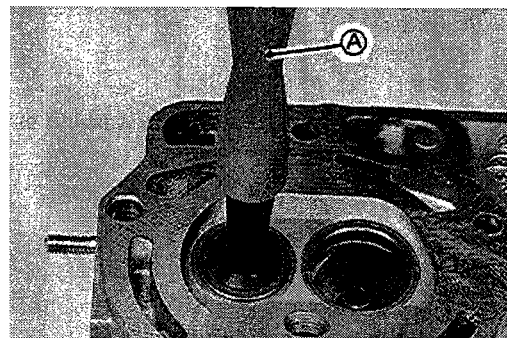
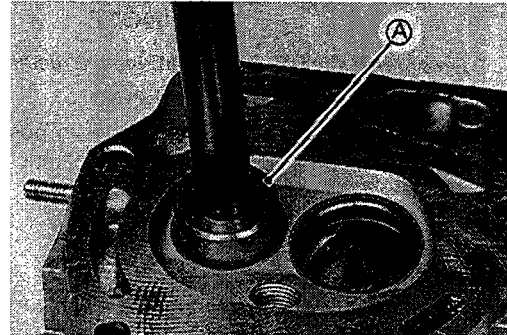
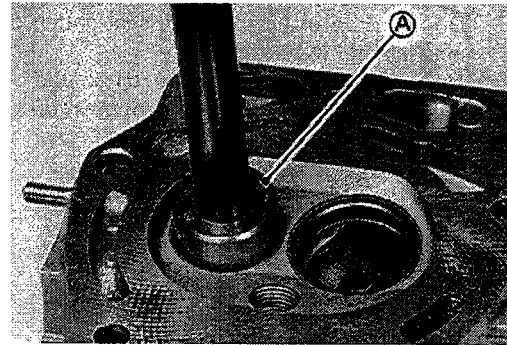

Valve Head Thickness

- Remove the valve.
- Measure the thickness of the valve head.
- ★ If the valve head thickness (valve margin) (1) is less than the service limit, replace the valve.

Valve Head Thickness
Service Limit (IN, EX): 0.6 mm (0.024 in)

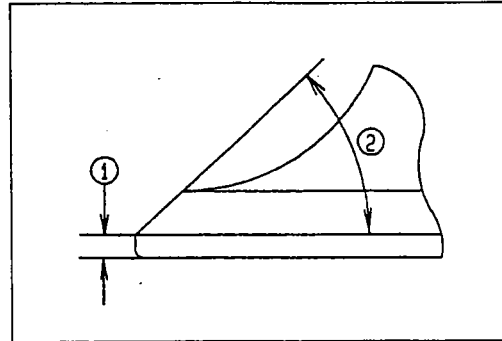

Valve Stem Run Out

- Support the valve in V blocks at each end of the stem.
- Position a dial gauge perpendicular to the stem.
- Turn the valve and read the variation on the dial gauge.
- ★ If the stem run out is greater than service limit, replace the valve.

Valve Stem Run Out
Service Limit (IN, EX): 0.05mm (0.002 in)

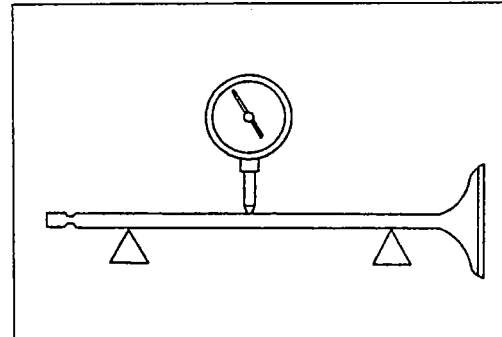

Valve Stem Diameter

- Measure the diameter of the valve stem (A) in two directions at right angles, at four different positions on the stem.
- ★ If any single measurement is less than the service limit, replace the valve.

Valve Stem Diameter
Service Limit:
Intake: 5.945 mm (0.2341 in)
Exhaust: 5.925 mm (0.2332 in)

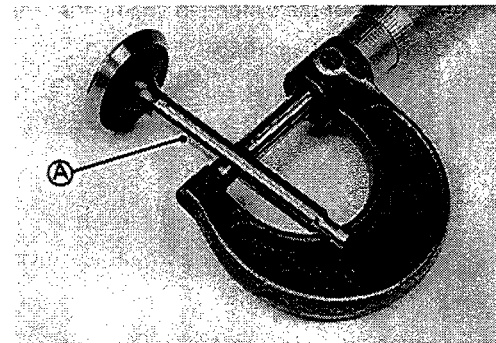

Valve Guide Inside Diameter

- Use a small bore gauge or a micrometer to measure the inside diameter of the valve guide a three places down the length of the guide.
- ★ If the measurement is more than the service limit, replace the cylinder head with a new one.

Valve Guide Inside Diameter
Service Limit
Intake: 6.045 mm (0.2379 in)
Exhaust: 6.055 mm (0.2384 in)

Valve Spring Inspection

- Inspect the valve spring for pitting, cracks, rusting, and burrs. Replace the spring if necessary.
- Measure the free length of the spring.
- ★ If the measurement is less than the service limit, replace the spring.

Valve Spring Free Length
Service Limit: 29.70 mm (1.17 in)

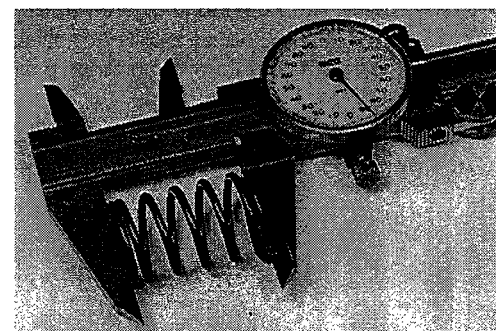

Cylinder, Piston

Piston Removal

- Split the crankcase (see Camshaft/Crankshaft chapter).
- Remove the camshaft (see Camshaft/Crankshaft chapter).
- Turn the crankshaft to expose the connecting rod cap bolts.
- Remove the bolts and take off the connecting rod caps.

A. Cap Bolts
B. Caps
C. Pry Points

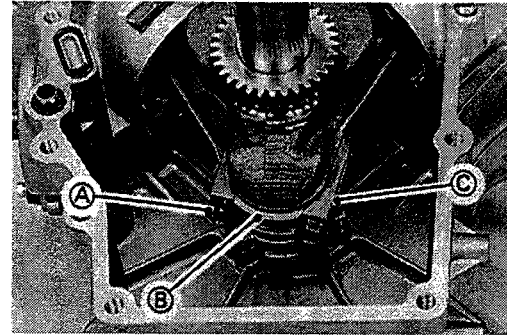

- Push the connecting rod end into the cylinder, and pull the piston and connecting rod out of the cylinder.

CAUTION

Note a location of the arrow match mark on the piston head in relation to **MADE IN JAPAN** on the connecting rod. No. 1 cyl. piston is opposite of No. 2 cyl. piston. Keep parts together as a set.

1. Arrow Match Marks
2. Flywheel Side
3. Large Chamfers
4. Raised Letters
(MADE IN JAPAN)

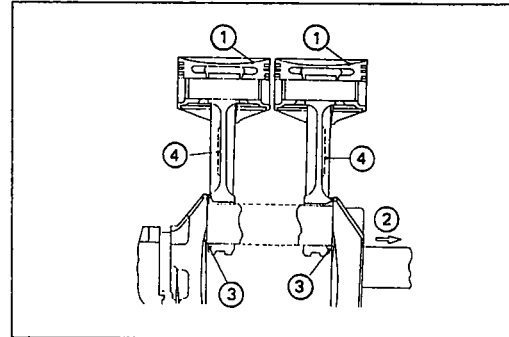

- Remove one of the piston pin snap rings with needle nose pliers.

A. Piston Pin Snap Rings
B. Pliers

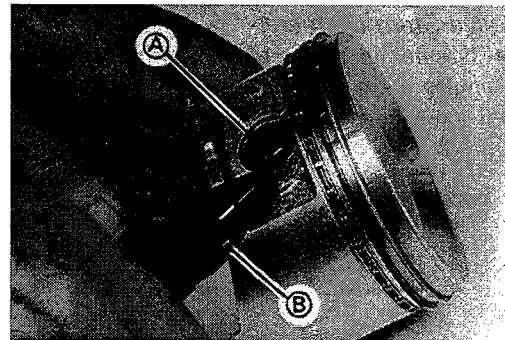

- Remove the piston by pushing the piston pin out the side from which the snap ring was removed.

A. Piston Pin



- Remove the top and second rings with a piston ring pliers (special tool: 57001-115). If the special tool is not available, carefully spread the ring opening with your thumbs and then push up on the opposite side of the ring to remove it.
- Remove the 3-piece oil ring with your thumbs in the same manner.

A. Piston Ring Pliers

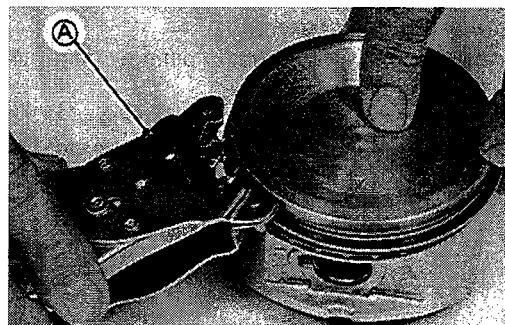

Piston Installation Notes

● **Oil Ring Installation:**

- First install the expander in the piston oil ring groove so that the expander ends butt together.
- Install the upper and lower steel rails. There is no UP or Down to the rails. They can be installed either way.

A. Expander ends

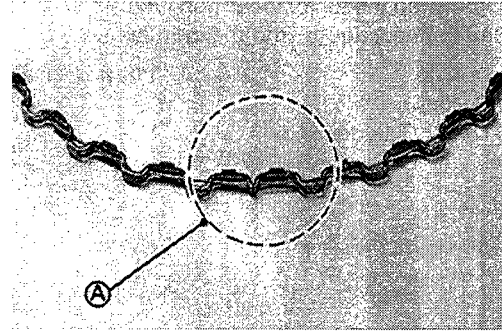

- Install the chrome-plated top ring and second ring with "N" mark facing up. The rings should turn freely in the grooves.
- Align the piston and rings with the piston ring end gap as shown.

1. Arrow Match Mark
2. Top Ring End Gap, Upper Side Rail End Gap
3. 45°
4. Second Ring End Gap, Lower Side Rail End Gap

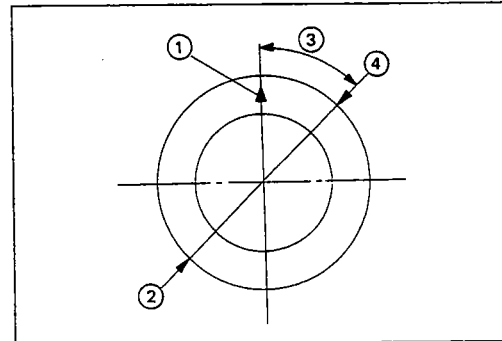

● Apply engine oil to the piston pins.

● Assemble the pistons onto the connecting rods as follow:

No. 1 Cyl. piston, align the arrow match mark on the piston head with the raised letters (MADE IN JAPAN) on the connecting rod.

No. 2 Cyl. piston, align the arrow match mark on the piston head with opposite MADE IN JAPAN on the connecting rod.

- | | |
|----------------------|---------------------------|
| A. No. 1 Cyl. Piston | D. MADE IN JAPAN |
| B. No. 2 Cyl. Piston | E. Opposite MADE IN JAPAN |
| C. Arrow Match Marks | |

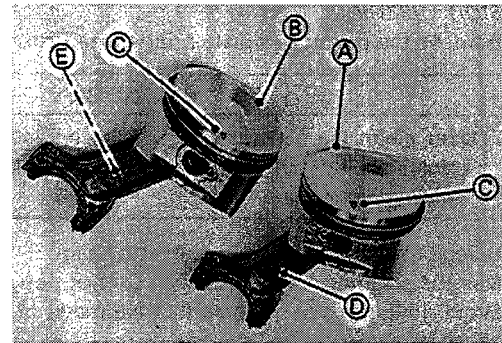

● When installing a piston pin snap ring, compress it only enough to install it and no more.

● Fit a new piston pin snap ring into the side of the piston so that the ring opening (A) does not coincide with the notch (B) in the edge of the piston pin hole.

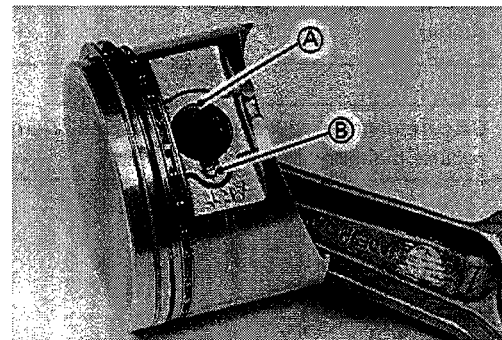

CAUTION

Do not reuse snap rings, as removal weakens and deforms them. They could fall out and score the cylinder wall.

● Apply engine oil to the piston skirt and the cylinder bore.

● Using the piston ring compressor grip (special tool: 57001-1095) and the belt (special tool: 57001-1097), insert the piston and connecting rod into the cylinder.

○ Insert the piston and connecting rod so that the arrow match mark on the top of the piston facing the flywheel side.

- A. Arrow Match Mark
 - B. Flywheel Side
- No. 1. Cylinder Shown

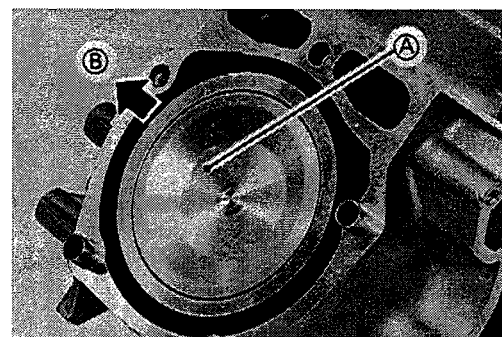

○ Lightly tap the top of the piston with a plastic mallet to insert the piston and connecting rod into the cylinder.

- A. Grip
 - B. Belt
 - C. Plastic Mallet
- No. 1. Cylinder Shown

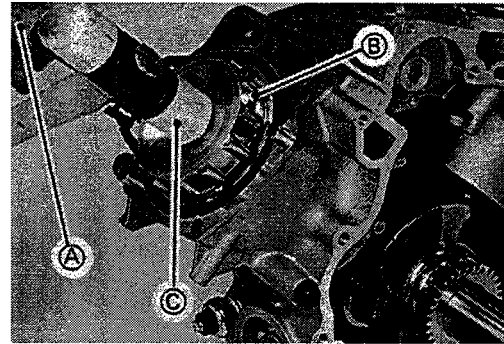

Piston/Cylinder Seizure

- In case of seizure, remove the piston.
- Visually inspect the cylinder and piston damage.
- ★ If there is only light damage, smooth the piston with #400 emery cloth. Remove the small aluminum deposits from the cylinder with #400 emery cloth or light honing.
- ★ If the damage is severe, the both cylinders must be bored oversize and an oversized pistons installed.

Piston Cleaning

- Remove the piston and piston rings (see Piston and Ring Removal).

CAUTION

<p>Never clean the piston head with the engine assembled. Carbon particles will fall between the piston and cylinder, and damage the crankshaft bearings.</p>

- Scrape the carbon off (A) the piston head.
- Use the scraping tools carefully. Do not gouge the piston head. To avoid gouging, use scrapers that are made of a material that will not cause damage.
- Clean the piston ring grooves (A) with a broken piston ring or other suitable tools.

CAUTION

<p>Be careful not to widen the ring grooves. Damaged ring grooves will require piston replacement.</p>
--

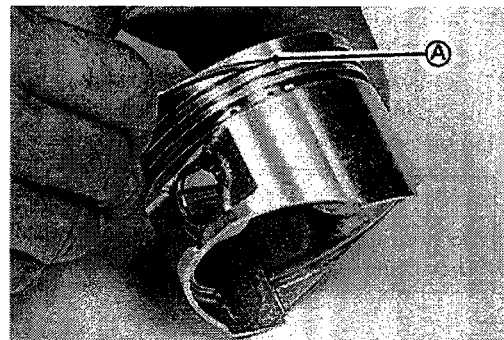
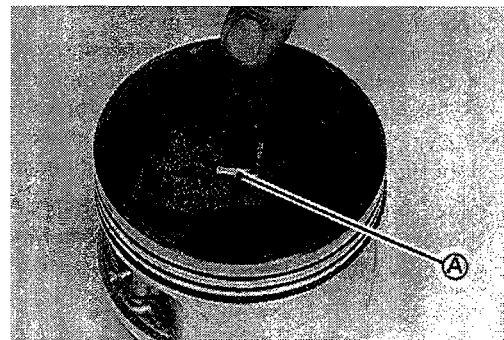

Piston Ring and Ring Groove Wear

- Clean the piston (see Piston Cleaning).
- Visually inspect the piston rings and ring grooves.
- ★ If the piston rings are worn unevenly or damaged, replace them.
- ★ If the ring grooves are worn unevenly or damaged, replace both the piston and piston rings.
- Check ring grooves for wear by inserting a new ring in the proper groove at several points around the piston.
- Measure the clearance between the top and second rings and their grooves using a thickness gauge (A).



★ If the piston ring/groove clearance is greater than the specified value, replace the piston.

Piston Ring/Groove Clearance

	Service Limit
Top	0.15 mm (0.006 in)
Second	0.12 mm (0.005 in)

NOTE

○ The oil ring is a three piece assembled ring. Difficult to measure the ring groove clearance and thickness, visually inspect only.

● Measure the piston ring thickness.

○ Use a micrometer to measure at several points around the rings.

★ If any of the measurement are less than the service limit, replace the entire set of rings.

Piston Ring Thickness

	Service Limit
Top	1.12 mm (0.044 in)
Second	1.12 mm (0.044 in)

NOTE

○ When using new rings in a used piston, check for uneven groove wear. The rings should fit perfectly parallel to the groove sides. If not, replace the piston.



Piston Ring End Gap

● Remove the piston rings.

● Push each ring (one at a time) in the cylinder bore to a point close to the bottom of the cylinder bore.

○ Use the piston to push it in to be sure it is square.

● Measure the gap between the ends of the ring (A) with a thickness gauge (B).

★ If the end gap of any ring is greater than the service limit, replace the entire set of rings.

Piston Ring End Gap

	Service Limit
Top, Second	1.2 mm (0.05 in)
Oil	1.5 mm (0.06 in)

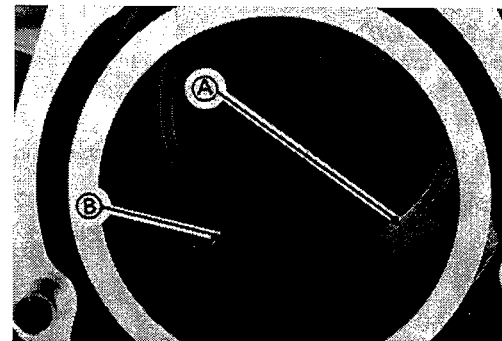

4-20 ENGINE TOP END

Piston Pin, Piston Pin Hole, and Connecting Rod Wear

- Remove the piston pin.
- Measure the diameter of the piston pin with a micrometer at several points.
- ★ If the outside diameter is less than service limit, replace the piston pin.

Piston Pin Outside Diameter

Service Limit: 16.975 mm (0.6683 in)

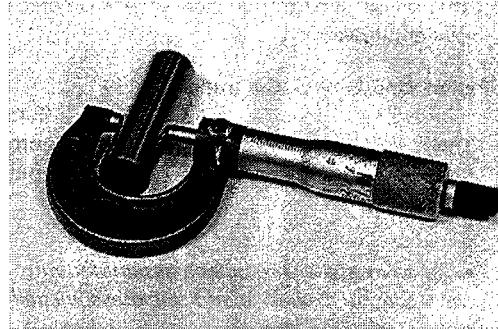

- Measure the inside diameter of the piston pin hole at several points on both side. Use a dial bore gauge.

★ If the inside diameter is more than the service limit, replace the piston.

Piston Pin Hole Inside Diameter

Service Limit: 17.041 mm (0.6709 in)

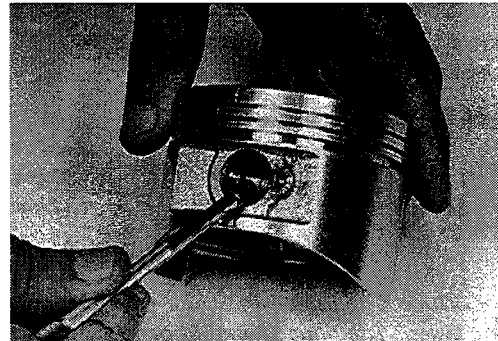

- Measure the inside diameter (A) of the small end of the connecting rod at several points. Use a dial bore gauge.

★ If the inside diameter is more than the service limit, replace the connecting rod.

Connecting Rod Small End Inside Diameter

Service Limit: 17.051 mm (0.6713 in)

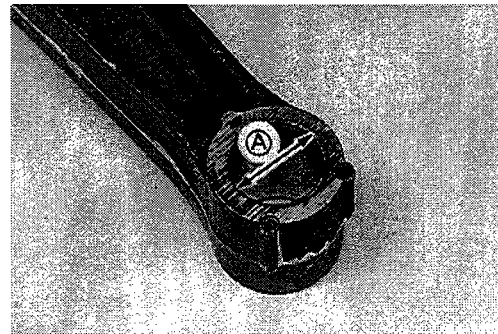

Piston Diameter

- Measure the outside diameter of the piston 11 mm (0.43 in) up from the bottom of the piston at a right angle to the direction of the piston pin hole.

★ If the measurement is less than the service limit, replace the piston.

Piston Diameter

Service Limit: 75.875 mm (2.9872 in)

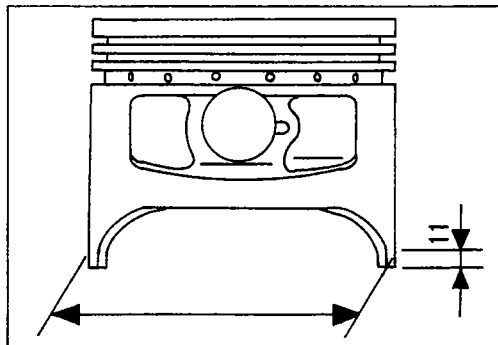

Cylinder Inside Diameter

- Clean and measure the cylinder inside diameter.
- Use a dial bore gauge to measure front-to-back and side-to-side at the points shown below.

★ If any of the cylinder bore measurements is greater than the service limit, the cylinder must be bored to the next oversize and then honed (see Cylinder Boring and Honing).

Cylinder Inside Diameter

Standard: 76.000 mm (2.9921 in)

Service Limit: 76.067 mm (2.9948 in)

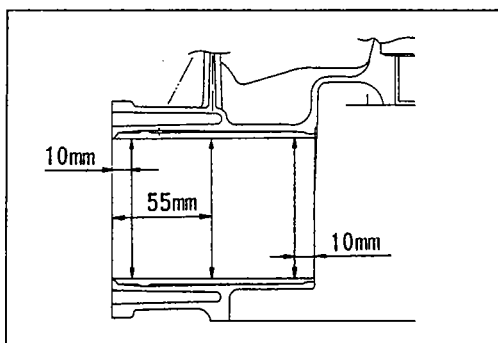

0.25 mm Oversize:	76.250 mm (3.0020 in)
Service Limit:	76.317 mm (3.0046 in)
0.5 mm Oversize:	76.500 mm (3.0118 in)
Service Limit:	76.567 mm (3.0144 in)
0.75 mm Oversize:	76.750 mm (3.0217 in)
Service Limit:	76.817 mm (3.0242 in)

Cylinder Bore Out-of-Round

Standard:	0.01 mm (0.0004 in)
Service Limit:	0.056 mm (0.0022 in)

Cylinder Boring and Honing

Always resize to exactly 0.25 mm (0.01 in), or 0.5 mm (0.02 in), 0.75 mm (0.03 in) over the standard bore size.

If this is done accurately, the stock oversize rings and pistons will fit perfectly and proper clearance will be maintained.

Resizing the cylinder bore can be done by reliable repair shop or by using a drill press and honing tool.

Use the stone recommended by the hone manufacturers to produce correct cylinder wall finish.

Machine-bore first, the bore diameters should be shown in the table.

Change to a honing stone for finishing, the final bore diameter should be as shown in the table.

Be sure the correct stone is used and the stone is not worn.

- Clean the cylinder at the top and bottom of the cylinder to remove burrs and pieces of the base and head gasket.
- Anchor the cylinder (block) on the drill press table before honing.
- Align the center of the cylinder bore to the press center. Set the press to operate from 200 to 250 rpm.
- Connect the drive shaft to the hone and set the stop on the drill press so the hone can only extend 20 to 25 mm (3/4 to 1.0 in) above the top or below the bottom of the cylinder liner.
- Rotate the adjusting nut (knob) on the hone until the stones contact snugly against the cylinder wall at the narrowest point. "Do not Force."
- Turn the stone by hand. If you cannot turn it, the stone is too tight. Loosen the hone until it can be turned by hand.
- Be sure that the cylinder and hone are centered and aligned with the drive shaft and drill spindle.
- Pour honing oil inside of the cylinder during the honing operation. Start the drill press. Move the hone up and down in the cylinder approximately 20 cycles-per-minute.
- Check the diameter of the cylinder bore regularly during honing, using an inside micrometer.

CAUTION

Stop the drill press before measuring and remove the hone from the cylinder.

NOTE

- The finish should not be smooth, but have a 40 to 60 degree crosshatch pattern.
- Hone the cylinder until it is about 0.007 to 0.009 mm (0.0003 to 0.0004 in) large to allow for shrinkage when the cylinder cools.

Fine Boring Bore Diameter

Oversize	Bore Diameter
0.25 mm	76.230 to 76.210 mm (3.0012 to 3.0004 in)
0.50 mm	76.480 to 76.460 mm (3.0110 to 3.0102 in)
0.50 mm	76.730 to 76.710 mm (3.0209 to 3.0201 in)

Final Bore Diameter

Oversize	Bore Diameter
0.25 mm	76.250 to 76.230 mm (3.0020 to 3.0012 in)
0.50 mm	76.500 to 76.480 mm (3.0118 to 3.0110 in)
0.50 mm	76.750 to 76.730 mm (3.0216 to 3.0209 in)

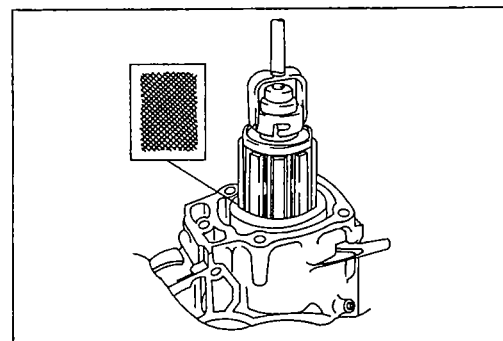

4-22 ENGINE TOP END

NOTE

- *Do not use gasoline, kerosene, or commercial solvent to clean the cylinder bore. These fluids only wash all the oil from the cylinder wall. They do not remove the metal particles produced during honing.*
- Clean the cylinder thoroughly. Use soap warm water and clean rags. Clean the cylinder wall for "white glove" inspection. A clean white rag should not show soil from the cylinder wall.
- Dry the cylinder and coat with a engine oil.

CAUTION

The cylinder must be thoroughly cleaned after honing to eliminate all grit.
--

Muffler

Muffler Assembly Removal

- Unscrew the exhaust pipe mounting nuts, and remove the spring washes and engine hook (B) [No. 2 Cylinder(C)]. Use a penetrating oil if necessary to breaking threads.
- Remove the bolts on the muffler bracket and take off the muffler assembly.
- Do not use unnecessary force on the exhaust pipes when removing the muffler assembly, or they could become damaged or distorted.

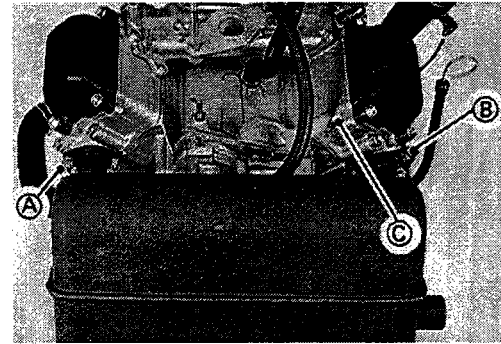

Muffler Assembly Installation Notes

- Clean the exhaust pipe flanges to the exhaust port gasket surfaces and install a new gaskets each time the muffler installed.
- Apply a non-permanent locking agent to the threads of the exhaust pipe mounting nuts.,
- To prevent mis-threading, finger tight the bolts (A) and nuts first. Next tighten the nuts, then the bracket (B) mounting bolts.
- After installation, thoroughly warm up the engine, wait until the engine cools down and retighten the bolts and nuts.

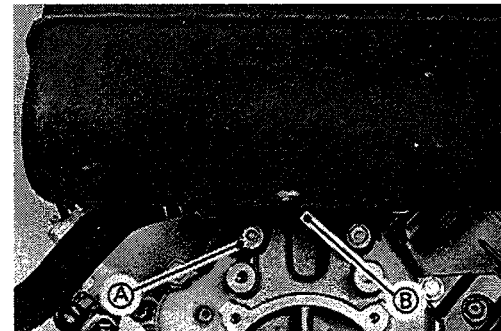

Inspection

- Inspect the exhaust pipes or muffler for dents, cracks, rust and holes.
- ★ If the exhaust pipes or muffler is damaged, it should be replaced for best performance and least noise.
- Check the muffler for distortion and/or loose internal components. Loss of power could develop if the muffler loose the internal components restricting the exhaust flow.
- Check for breaks in the seams and check weld at the junction of the exhaust pipes and muffler.
- Tap the muffler with a plastic hammer to decarbonize.

For Kawasaki Discount Parts Call 606-678-9623 or 606-561-4983

Lubrication System

Table of Contents

Exploded View	5-2
Engine Oil Flow Chart.....	5-3
Specifications	5-4
Engine Oil and Oil Filter.....	5-5
Oil Level Inspection	5-5
Oil Change	5-6
Oil Filter Removal	5-6
Oil Filter Installation Notes	5-7
Pressurized Lubrication System.....	5-8
Oil Pressure Measurement.....	5-8
Oil Pressure Switch Inspection	5-8
Oil Pump and Relief Valve	5-9
Removal	5-9
Installation Notes	5-9
Inspection.....	5-9
Oil Screen Filter	5-12
Removal	5-12
Installation Notes	5-12
Cleaning and Inspection.....	5-12

Engine Oil Flow Chart

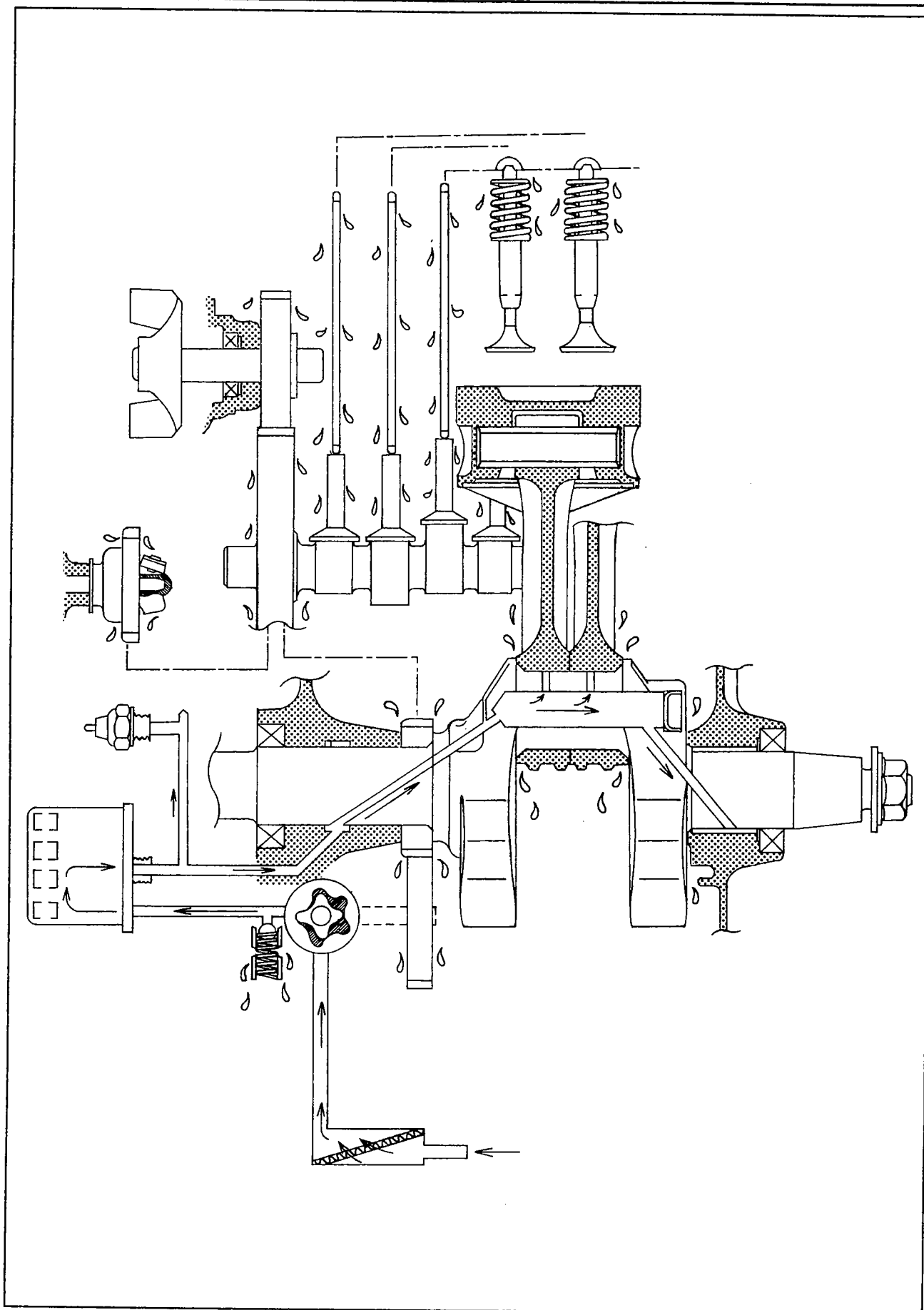

5-4 LUBRICATION SYSTEM

Specifications

Item	Standard
Engine Oil: Grade Viscosity Capacity Level Oil Pressure (MIN) Oil Pressure Switch: Detect pressure Screw Oil Filter By-pass Valve Opening Pressure	API Service Classification ; SC, SD, SE, SF, SG, or SH SAE40, SAE30, SAE10W-30 / SAE10W-40, or SAE5W-20 (see Oil Change) 1.8L (3.80 US pt) [When filter is not removed] 1.5L (3.17 US pt) [When filter is removed] Between upper and Lower level line 276 kPa (40 psi) 98 kPa (14.2 psi) PT 1/8 pipe thread 78.5 to 117.5 kPa (11.4 to 17.1 psi)

Item	Service Limit
Oil Pump: Inner and outer rotor clearance Outer rotor outside diameter Outer rotor thickness Pump housing inside diameter Pump housing depth Pump shaft outside diameter Relief valve spring free length Pump shaft bearing inside diameter	0.3 mm (0.012 in) 40.470 mm (1.5933 in) 9.830 mm (0.387 in) 40.801 mm (1.606 in) 10.230 mm (0.4028 in) 10.923 mm (0.4300 in) 19.50 mm (0.77 in) 11.072 mm (0.4359 in)

Engine Oil and Oil Filter

CAUTION

Engine operation with insufficient, deteriorated, or contaminated engine oil will cause accelerated wear and may result in engine seizure and accident.

Oil Level Inspection

- Place the engine on a level surface and check the oil level.
- Clean area around the dipstick (A) before removing it.
- Remove the dipstick and wipe it with a clean cloth.
- Insert the dipstick into tube (B) following the tube bend and let it's plug firmly fit into the tube, then check the oil level.
- The oil level should be between the "H" and "L" marks on the dipstick.
- ★ If the oil level is near or below the "L" mark, remove the oil filler cap (C) and add enough engine oil to bring oil level to the "H" mark.

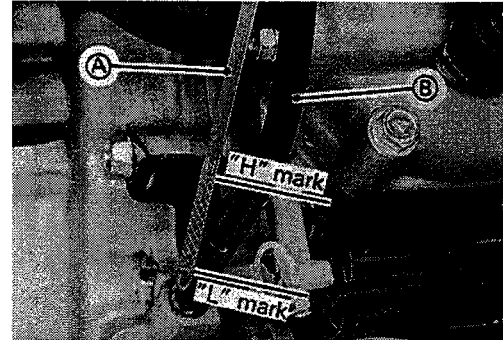

CAUTION

Do not fill above the "H" mark. Excess oil will cause a smoking condition, and may cause the engine to overheat.

- ★ If the oil level is too high, remove the excess oil by loosening the drain plug (D).

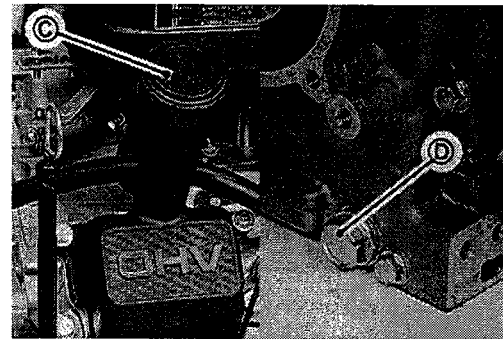

CAUTION

Before starting the engine for the first time, add oil: The engine is shipped dry. Preoil the engine to force all air from the internal oil passages and the oil filter.

- Fill fresh engine oil to the specified level.
- Run the engine at slow speed 2 minutes.
- Stop the engine and check the oil level.
- Add oil only to the "H" mark on the dipstick. Use the same type and make of oil that is already in the engine.

NOTE

- If the engine oil type and make are unknown, use any brand of the specified oil to top up the level in preference to running the engine with the oil level low. Then at your earliest convenience, change the oil completely.

5-6 LUBRICATION SYSTEM

Oil Change

- Change oil after first 8 or 20 hours of operation. Thereafter change oil every 100 hours.
- Check that there is oil in the crankcase.
- Start and warm up the engine so the oil will drain easily. Stop the engine.
- Place the engine on a level surface.
- Tilt the engine and place a suitable container under the engine.
- Remove the drain plug (A), and let the oil drain completely.

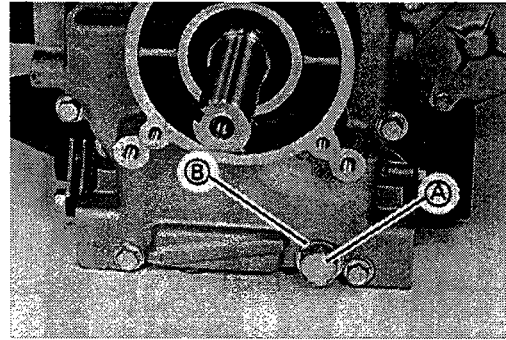

▲ WARNING

Be careful with not oil being drained. If may be not enough to burn you severely.

- Check the gasket (B) at the drain plug for damage. Replace the gasket with a new one if it is damaged.
- Install the drain plug with the gasket and tighten it to the specified torque (see Exploded View).

- Remove the oil filler cap and refill the engine with a high quality oil of recommended viscosity in the chart.

CAUTION

Use a good quality SC, SD, SE, SF, SG or SH class oil. Choose the viscosity of oil for temperature expected.

- Check the oil level (see Oil Level Check).

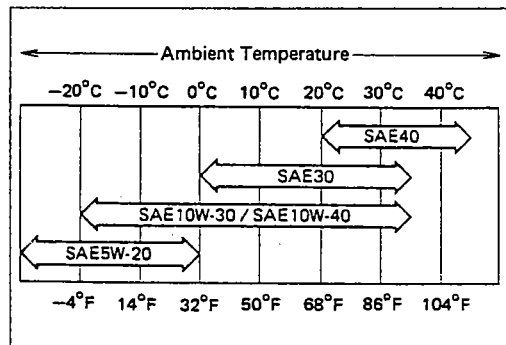

NOTE

○ Some increase in oil consumption may be expected when a multi grade engine oil is used. Check the oil level frequently.

Engine Oil Capacity

- Capacity: **1.8 L (3.80 U.S. Pt)**
[When filter is not removed]
- 1.5 L (3.17 U.S. Pt)**
[When filter is removed]

Engine Oil Level

Between upper and lower level line

Oil Filter Removal

- Using a strap wrench (B), remove the oil filter.
- When unscrewing the oil filter (A), place a suitable container beneath the oil drip tray (C) to receive oil from the oil filter and oil passages in the engine. Turn the filter counterclockwise to remove it.

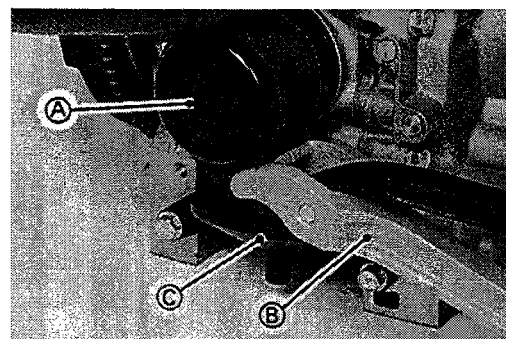

Oil Filter Installation Notes

- Apply a thin coat of grease to the seal (A).
- Install a new filter.
- Turn the filter until the seal contacts mounting surface (B) of the engine. Then turn the filter BY HAND(S) 3/4 turn more.
- Run the engine at slow idle speed 2 minutes. Check for leaks around the engine.
- Stop the engine. Check the oil level (see Oil Level Check). Add oil only to the "H" mark on the dipstick.

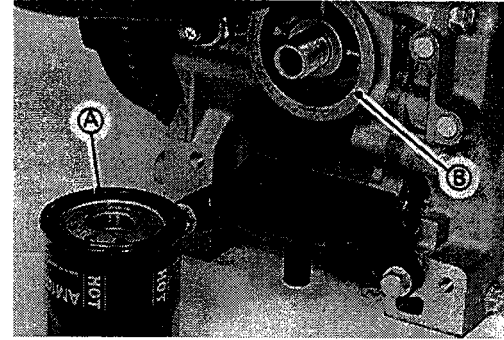

5-8 LUBRICATION SYSTEM

Pressurized Lubrication System

The engine lubrication circuit is a pressurized system consisting of a positive displacement pump which picks up oil through a filter screen from the crankcase. The oil is pumped to a replaceable oil filter cartridge, through the engine's oil passages to lubricate internal components, and return to the crankcase. A bypass valve is incorporated in the oil filter to allow oil to circulate if the filter becomes clogged. A pressure relief valve is used between the oil pump and oil filter to relieve excessive oil pressure by returning excess oil to the crankcase (see Oil Flow Chart).

Oil Pressure Measurement

- Remove the oil pressure switch (A) from the crankcase.
- Install an appropriately sized oil pressure gauge adapter and oil pressure gauge.
- Run the engine and allow warm up completely.
- Run the engine at fast idle speed and read the oil pressure gauge.
- Stop the engine.
- Remove the oil pressure gauge and adapter.
- Apply a non-permanent locking agent to the taper threads of the pressure switch and install the switch.
- ★ If the oil pressure is below the specification, inspect the oil pump and relief valve.
- ★ If the oil pump and relief valve are not at fault, inspect the rest of the lubrication system.

Oil Pressure (Minimum)
276 kPa (40 psi)

Oil Pressure Switch
PT 1/8 (Taper Pipe Threads)

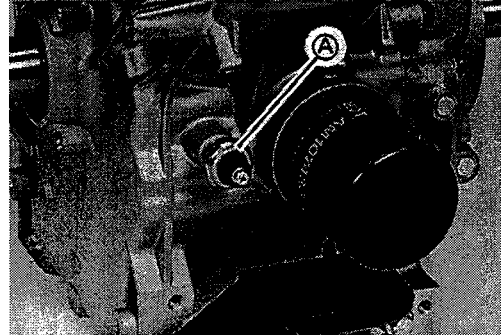

Oil Pressure Switch Inspection

When the oil pressure falls below 69 kPa (10 psi), the oil pressure switch activates the oil warning lamp to alert the operator of a lubricating problem.

- To check the oil warning system, insert the switch key into the "OFF" position of the engine switch, then turn it to the "RUN" position. The warning light must be illuminated.
- Whenever start the engine, make sure the warning light is not on in started engine.
- ★ If the warning light comes on, stop the engine immediately and check the oil level.
- When starting the engine, note the warning light on dash carefully.
- ★ If the warning light is on in the started engine in spite of adequate oil level, check the lead from the pressure switch to the warning light for short circuit and/or check the pressure switch and replace damaged part.
- ★ If the light is not on at the moment of the engine switch operation, check all leads of the warning light circuit or bulb and replace damaged parts.

Oil Pump and Relief Valve

Removal

- Split the crankcase (see Camshaft/Crankshaft chapter).
- Unscrew the mounting screws and take off the oil pump parts assembly (pump gear, pump cover plate, pump shaft, pins and rotors).
- Take off the relief valve spring and ball.
- Disassemble the pump parts assembly

- | | |
|-------------------|----------------------|
| 1. Pins | 6. Pump Shaft |
| 2. Pump Gear | 7. Relief Valve Ball |
| 3. Mounting Bolts | 8. Spring |
| 4. Outer Rotor | 9. Pump Cover Plate |
| 5. Inner Rotor | 10. 6mm DIA Hole |

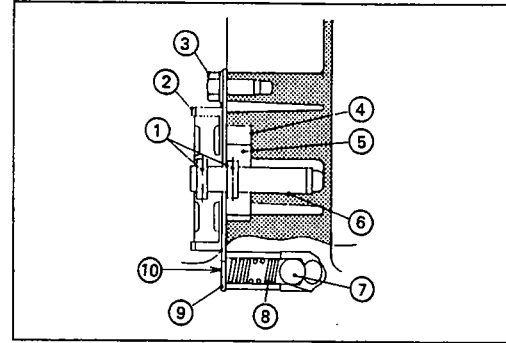

Installation Notes

- Fill the rotor housing with engine oil for initial lubrication.
- Install the relief valve ball and spring in position, then install the pump parts assembly in the crankcase cover.

NOTE

○ When Installing the pump parts assembly, align the 6mm DIA hole (A) on the cover plate with center of the relief valve.

- Install the mounting bolts and tighten them securely.

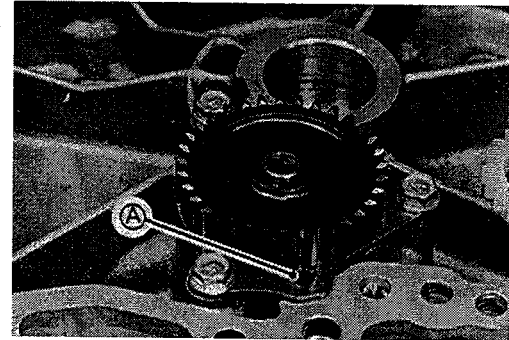

Inspection

- Remove the oil pump.
- Visually inspect the pump gear, outer and inner rotor, and cover plate.
- ★ If there is any damage or uneven wear, replace them.
- Check the clearance (A) between the inner and outer rotor with a feeler gauge. Measure the clearance between the high point of the inner rotor and the high point of the outer rotor.
- ★ If the measurement exceed the service limit, replace the rotors as a set.

Inner and Outer Rotor Clearance

Service Limit: 0.3mm (0.012 in)

- Measure the outside diameter (A) of the outer rotor with a micrometer at several points.
- ★ If the rotor diameter is less than the service limit, replace both the inner and outer rotor.

Outer Rotor Diameter

Service Limit: 40.470 mm (1.5933 in)

- Measure the thickness (B) of the outer rotor with a micrometer at several points.
- ★ If the rotor thickness is less than the service limit, replace both the inner and outer rotor.

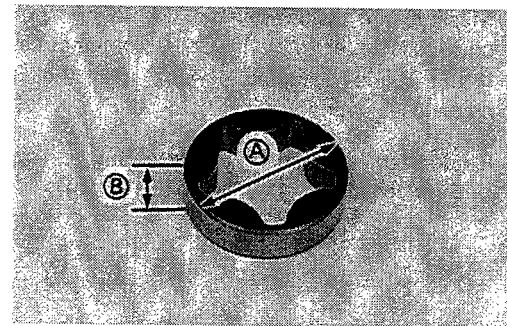
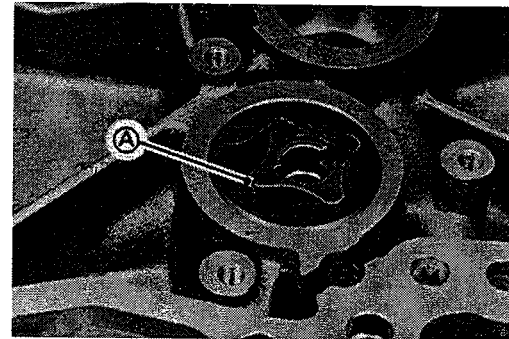

Outer Rotor Thickness

Service Limit: 9.830 mm (0.3870 in)

5-10 LUBRICATION SYSTEM

- Measure the inside diameter (A) of the pump housing with a inside micrometer at several points.
- ★ If the inside diameter is more than the service limit, replace the crankcase cover.

Pump Housing Inside Diameter

Service Limit: 40.801 mm (1.6063 in)

- Measure the depth (B) of the pump housing with a depth micrometer at several points.
- ★ If any of measurement is more than the service limit, replace the crankcase cover.

Pump Housing Depth

Service Limit: 10.230 mm (0.4028 in)

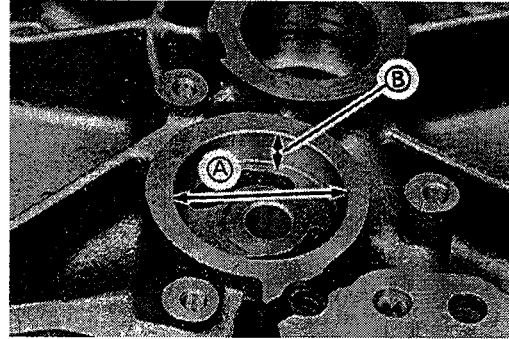

- Measure the outside (A) diameter of the pump shaft with a micrometer at several points.
- ★ If the diameter is less than the service limit, replace the pump shaft.

Pump Shaft Diameter

Service Limit: 10.923 mm (0.4300 in)

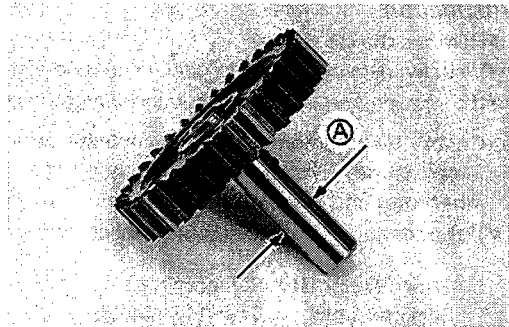

- Measure the inside diameter (A) of the pump shaft bearing in the crankcase cover with a inside micrometer at several points.
- ★ If the inside diameter is more than the service limit replace the crankcase cover.

Inside Diameter of Pump Shaft Bearing

Service Limit: 11.072 mm (0.4359 in)

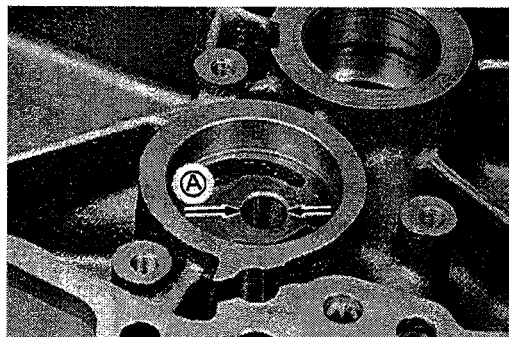

- Visually inspect the relief valve spring, steel ball and valve seat in the crankcase cover.
- ★ If any rough spots are found during above inspection, wash the valve clean with a high flash-point solvent and blow out any foreign particles that may be in the valve with compressed air.

⚠WARNING

Clean the parts in a well ventilated areas and take care that there is no spark or flame anywhere near the working areas. Because of the danger of highly flammable liquids, do not use gasoline or low flash-point solvents.

- ★ If cleaning does not solve the problem, replace the relief valve parts.
- ★ If necessary, put the ball in position and lightly tap the ball with a suitable tool to form a perfect seat.
- Measure free length (A) of the spring with a vernier caliper.
- ★ If the free length of the spring is less than the service limit, replace the spring.

Free Length of Spring

Service Limit: 19.50 mm (0.77 in)

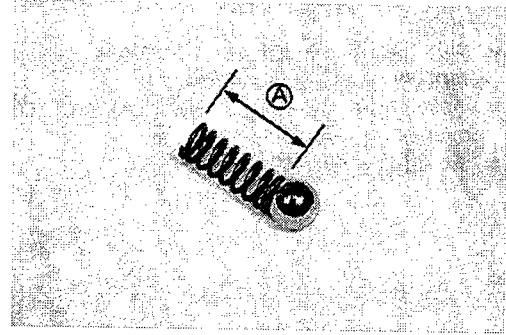

5-12 LUBRICATION SYSTEM

Oil Screen Filter

Removal

- Split the crankcase and remove the crankcase cover (see Camshaft/Crankcase chapter).
- Unscrew the mounting screws (A) and remove the filter chamber cover (B) with oil induction pipe.
- Pick up the filter screen.

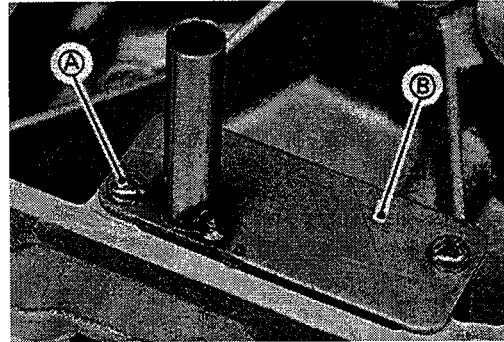

Installation Notes

- Clean the oil filter screen (A) thoroughly whenever it is removed for any reason.
- Insert the screen in position and install the chamber cover.
- Install the screws and tighten them securely.

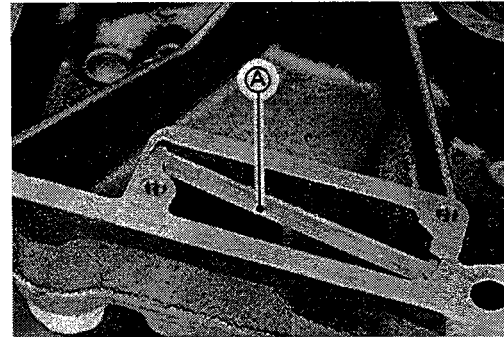

Cleaning and Inspection

- Clean the oil screen with high flash-point solvent and remove any particles stuck to it.

⚠ WARNING

Clean the screen in a well-ventilated area, and take care that there is no spark or flame anywhere near the working area. Because of the danger of highly flammable liquids, do not use gasoline or low flash-point solvents.

NOTE

- While cleaning the screen, check for any metal particles that might indicate internal engine damage.
- Check the screen carefully for any damage: holes and broken wire.
- ★ If the screen is damaged, replace it.

Camshaft/Crankshaft

Table of Contents

Exploded View	6-2
Specifications	6-3
Crankcase	6-4
Splitting	6-4
Assembly	6-4
Inspection	6-5
Journal Bushing Replacement	6-6
For Designing Bushing Tools	6-7
Breather	6-8
Removal	6-8
Installation Notes	6-8
Inspection	6-8
Camshaft Tappet	6-9
Removal	6-9
Installation Notes	6-9
Inspection	6-9
Camshaft Bearing/Journal Wear	6-9
Crankshaft, Connecting Rod	6-11
Connecting Rod Removal	6-11
Connecting Rod Installation Notes	6-11
Crankshaft Removal/Installation Notes	6-11
Cleaning/Inspection	6-12
Connecting Rod Bend/Twist	6-12
Connecting Rod Big End/Crankpin Width Wear	6-12
Connecting Rod Big End Bearing/Crankpin Wear	6-13
Crankshaft Runout	6-13
Crankshaft Main Journal/Wear	6-14
Crankpin Resizing	6-14

6-2 CAMSHAFT/CRANKSHAFT

Exploded View

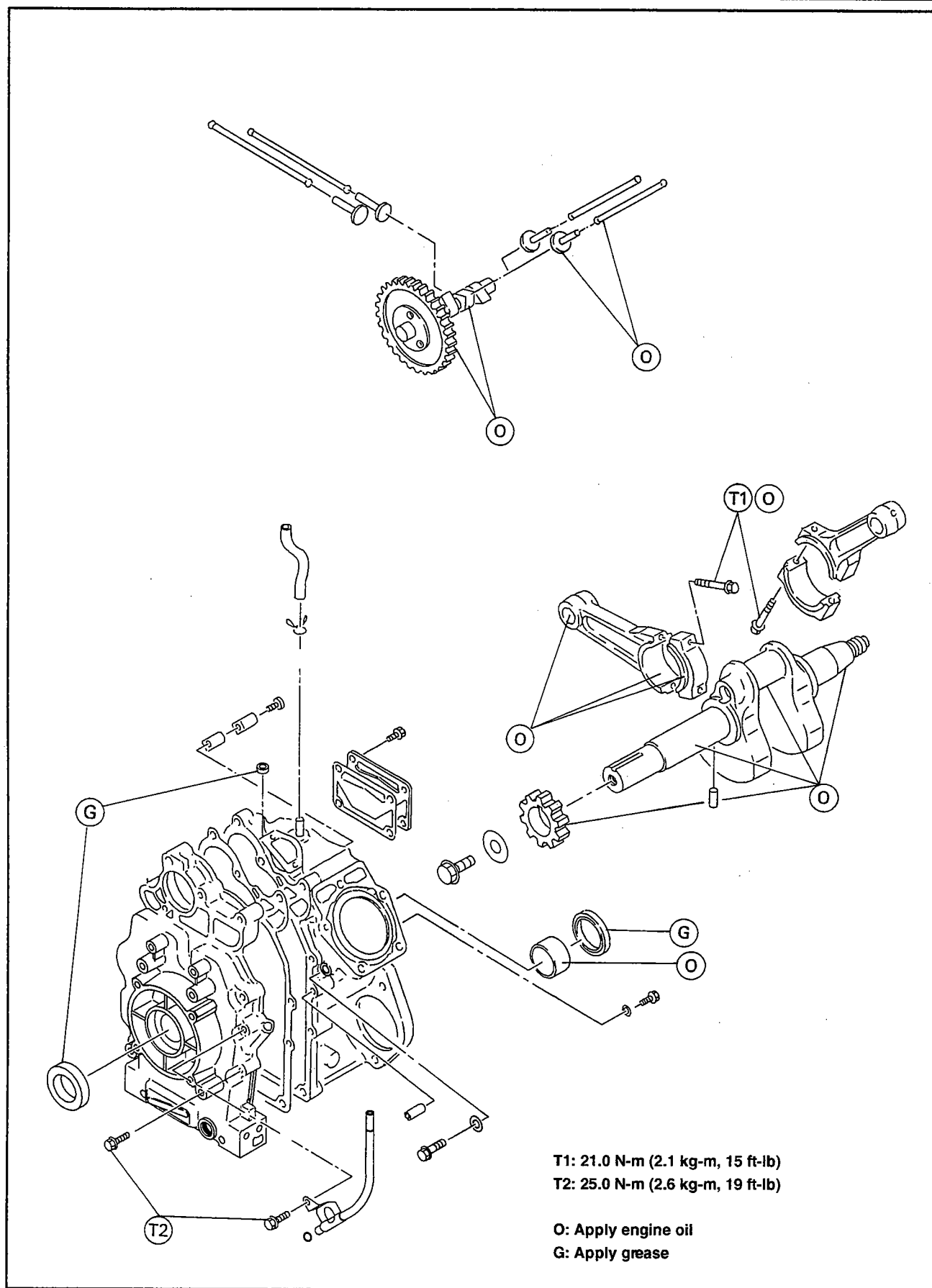

CAMSHAFT/CRANKSHAFT 6-3

Specifications

Item		Service Limit
Camshaft, Tappet:		
Cam lobe height	Intake	25.21 mm (0.993 in)
	Exhaust	25.46 mm (1.002 in)
Camshaft journal diameter	PTO side	15.907 mm (0.6263 in)
	Flywheel side	15.917 mm (0.6267 in)
Camshaft bearing inside diameter	Crankcase	16.068 mm (0.6326 in)
	Crankcase cover	16.068 mm (0.6326 in)
Crankshaft, Connecting Rod:		
Connecting rod bend		0.15/100 mm (0.006/3.94 in)
Connecting rod twist		0.15/100 mm (0.006/3.94 in)
Connecting rod big end width		21.20 mm (0.83 in)
Crankpin width		44.5 mm (1.75 in)
Connecting rod big end inside dia.		34.055 mm (1.3407 in)
Crankpin outside diameter		33.927 mm (1.3357 in)
Crankshaft runout		0.05 mm (0.002) TIR
Crankshaft journal diameter	PTO side	33.909 mm (1.3350 in)
	Flywheel side	33.909 mm (1.3350 in)
Crankcase:		
PTO shaft bearing inside diameter	Crankcase cover	34.066 mm (1.3412 in)
Water pump shaft bearing inside dia.		10.088 mm (0.3972 in)
Crankshaft journal bearing Inside dia.	Crankcase	34.114 mm (1.3431 in)

6-4 CAMSHAFT/CRANKSHAFT

Crankcase

Splitting

- Set the engine on a clean surface while parts are being removed.
- Remove (see appropriate chapter).
 - Muffler Assembly
 - Air Cleaner Assembly
 - Carburetor Assembly
 - Throttle Control panel
 - Radiator
 - Radiator Hoses and Bypass Tube
 - Water pump Assembly
 - Cooling Fan and Brackets
 - Cylinder Head Assemblies
 - Intake Manifold
 - Flywheel
 - Stator coil
 - Pulser coils
 - Ignition coils
 - Igniter
 - Starter Motor
 - Igniter and Bracket
 - Oil Drip Tray
 - Oil Filter
- Unscrew the mounting bolts in the order shown and pull the crankcase cover from the crankcase.
- There are two knock pins on the crankcase mating surface. A wooden or plastic mallet may be used to gently tap loose the crankcase cover.

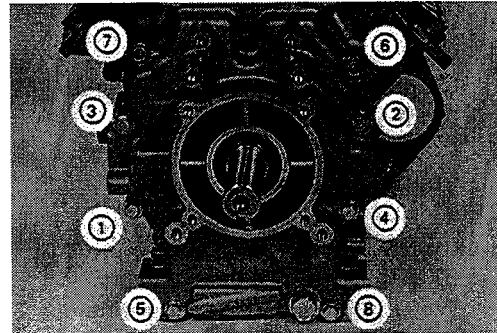

Assembly

- Before fitting the cover onto the crankcase, note the following.
- Chip the old gasket off the mating surfaces of the crankcase and cover, and clean off the crankcase, crankshaft and other internal components. After cleaning apply engine oil to any rubbing surface of these components.
- Be sure to replace any oil seal removed with a new one. The oil seal must be assembled with spring (1) loaded lip toward inside of the engine.
- Pack some amount of a high temperature grease (5) into the space between the seal lip (2) and dust lip (3). Press in the new oil seal using a press or suitable tools until it is flush with flange surface (4). Do not damage the seal lips.

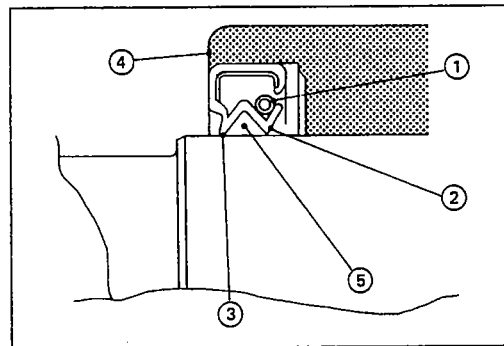

- Check that the governor weights are closed.
- Be sure to suitably set the governor gear to be meshed with the cam gear and the oil pump gear to be meshed with the crank gear when installing crankcase cover. Do not force the crankcase cover into position.

Gear train: viewed from PTO side

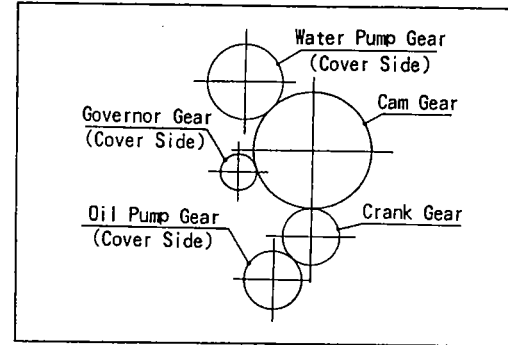

- Note the position of different length of the bolts.
- Install the crankcase cover and tighten the case cover bolts to the specified torque (see Exploded View) in the sequence as shown. Do not turn one screw down completely before the others, as it may cause a warped the crankcase cover.

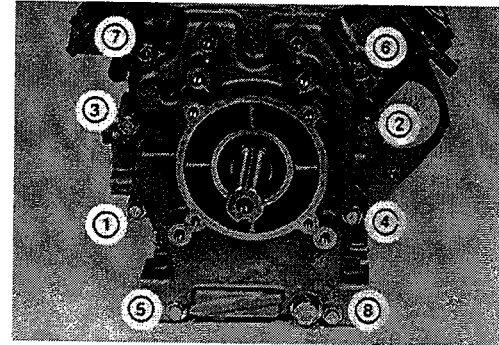

Inspection

- Clean up the crankcase and cover with a high flash-point solvent, and blow out any foreign particles that may be in the pockets inside of the crankcase with compressed air.

▲ WARNING

Clean the crankcase and cover in a well-ventilated area, and take care that there is no spark or flame anywhere near the working area. Because of the danger of highly flammable liquids, do not use gasoline or low flash-point solvents.

- Inspect the crankcase for accumulation of rust, scale and lime in the water jacket.
- ★ If this accumulation is observed, flush the cooling system (see Flushing in Cooling System chapter).
- Inspect the crankcase for coolant leakage out side water jacket. Small leaks may appear only as rust, corrosion or stains, due to evaporation.
 - Gaskets: Tighten a parts or install a new gasket. Use a sealing compound when required.
 - Bolts: Apply sealing compound when required.
- Inspect the crankcase for coolant leakage into the engine.
 - A. Water Jacket
 - B. Gasket Surfaces
 - C. Push Rod Compartment
- A coolant leaks into the engine through:
 - A loose cylinder head
 - A cracked or porous casting
 - The push rod compartment
- Give special attention to the cylinder head gasket.
- ★ If coolant leaks from the gasket surfaces:
 - Check the gasket surfaces for burn and traces of the gas leakage, replace the gasket if necessary.
 - Check the cylinder head and block surfaces are clean, level and smooth. (see Engine Top End chapter)
 - Check the cylinder head for correct installation (see Engine Top End chapter).

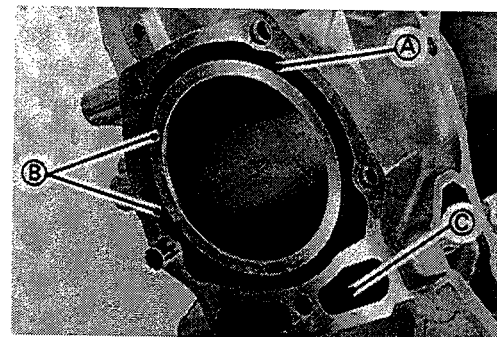

6-6 CAMSHAFT/CRANKSHAFT

- A cracked or porous casting are not visible to eye, an evidence of leakage of the coolant from suspected area are found, replace the crankcase (block).
- ★ If a coolant leakage from the push rod compartment is appeared replace the crankcase (block).

- Measure the inside diameter (A) of the PTO shaft bearing on the crankcase cover at several points. This bearing is not replaceable. Replace the crankcase cover if the inside diameter is more than the service limit.

PTO Shaft Bearing Inside Diameter
Service Limit: 34.066 mm (1.3412 in.)

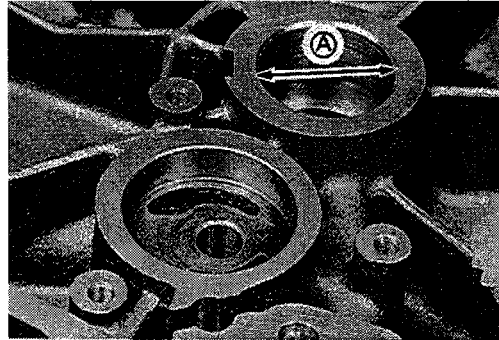

- Measure the inside diameter (A) of the water pump shaft bearing on the crankcase at several points. This bearing is not replaceable. Replace the crankcase cover if the inside diameter is more than the service limit.

Water Pump Shaft Bearing Inside Diameter
Service Limit: 10.088 mm (0.3972 in.)

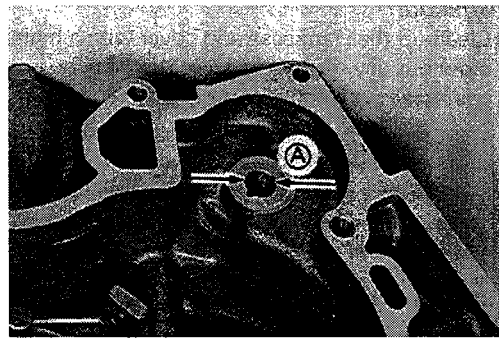

- Measure the inside diameter (A) of the crankshaft journal bearing on the crankcase at several points. Replace the journal Bushing if the inside diameter is more than the service limit.

Crankshaft Journal Bearing Inside Diameter
Service Limit: 34.114 mm (1.3431 in.)

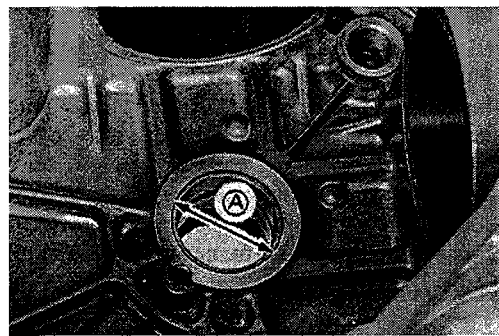

Journal Bushing Replacement

- The journal bushing (2) is press fit into the crankcase (1).
- Remove the oil seal on the crankcase.
The oil seal should not be reused once removed.
 - Place the crankcase on a support block (4) with the oil seal side up.
 - Using a bushing tool (3), drive out the bushing as shown.

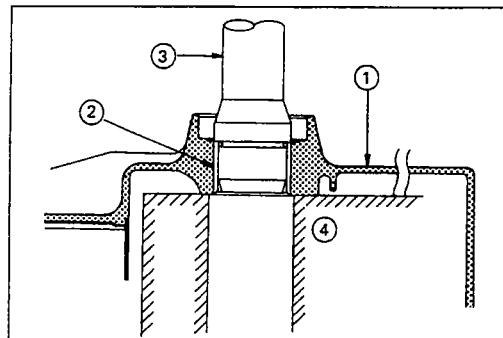

- The service bushing is to be reinstalled using a bushing tool as shown.
- Coat the bushing and flange surface with light film of oil, press in the new bushing flush with the flange surface.
- No finish reaming is required.

- | | |
|-------------------|------------------|
| 1. Flange Surface | 3. Bushing Tool |
| 2. New Bushing | 4. Support Block |

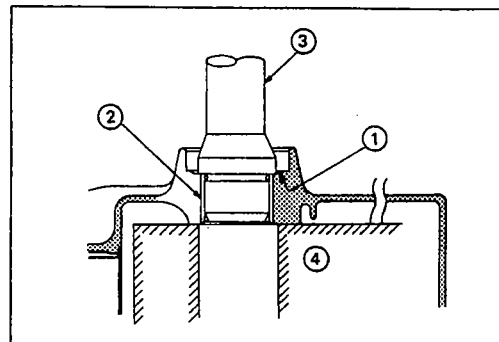

For Designing Bushing Tools

- | | |
|----------------------------------|------------------------|
| 1. Bushing Inside Diameter (MIN) | 33.997 mm (1.3385 in.) |
| 2. Housing Inside Diameter (MIN) | 38.000 mm (1.4961 in.) |
| 3. Bushing Width | 26.0 mm (1.02 in.) |
| 4. Bushing Counter Sunk | 1.0 mm (0.04 in.) |

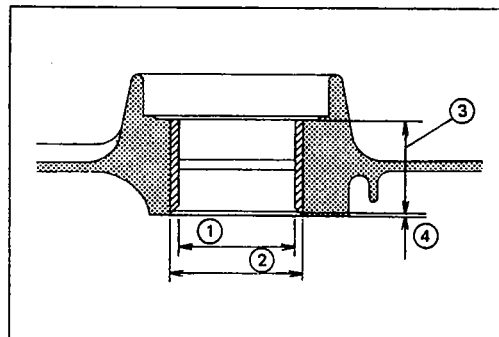

6-8 CAMSHAFT/CRANKSHAFT

Breather

The function of the breather is to create a vacuum in the crankcase which prevent oil from being forced out of the engine through the piston rings, oil seals or gaskets. The breather has a reed valve (C), which limits the direction of air flow caused by the piston moving up and down. Air can flow out of the crankcase, but the one way reed valve blocks return flow. It thus maintains a vacuum in the crankcase.

Oil laden air in the crankcase passes through the reed valve and expand into the breather chamber. Here most oil separates from the air and drains back to the crankcase. The air passes through a maze (E) and vents to the air cleaner (F).

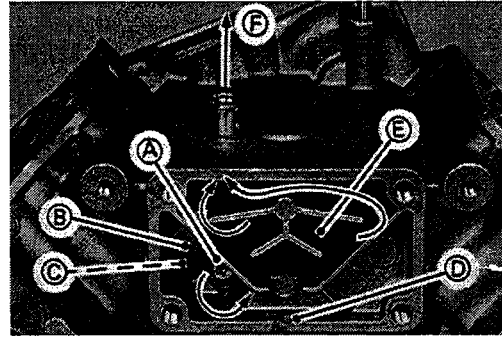

Removal

- Remove the breather chamber cover.
- Unscrew the mounting screw (A), and remove the back plate (B) and reed valve.

Installation Notes

- Be sure the drain back hole (D) does not accumulate with sludges before installing the breather valve.
- Align center of the valve seat with center of the reed valve and back plate, then tighten the mounting screw.

NOTE

- *The mounting screw is a self-tapping one. Be aware that misthreading or overtightening screw will strip the female threads and ruin the hole.*

Inspection

- Inspect the reed valve for breakage, hair cracks or distortion, replace it if necessary.
- Inspect the back plate for damage or rough contact surface, replace it if necessary.
- Inspect the valve seating surface. The surface should be free of nicks or burrs.

Camshaft Tappet

Removal

- split the crankcase (see Crankcase Splitting).
- Turn the crankcase up side down so that the tappets will fall away from the cam lobes.
- Pull the camshaft out of the crankcase.

NOTE

○ Before removing, align the punch mark (A) on the crankgear with the projection (B) on the camgear.

- Remove the tappets and mark them so they can be installed in their original positions during assembly.

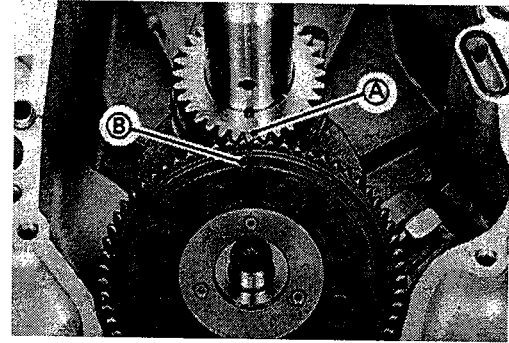

Installation Notes

- Apply engine oil to the following.
 - Tappet Journal
 - Camshaft Journal
 - Cam Lobe Surface
 - Cam shaft Gear
- Align the punch mark on the crankgear with the projection on the camgear.

Inspection

- Check the camshaft gear (A) for pitting, fatigue cracks, burrs or an evidence of improper tooth contact. Replace the shaft if necessary.
- Check the top of the cam lobes (B) for wear, burrs or uneven contact. Replace the shaft if necessary.

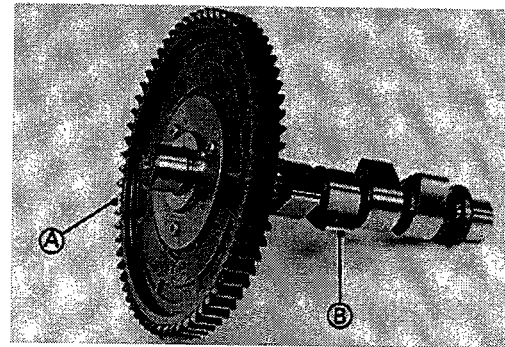

Camshaft Bearing/Journal Wear

- Measure the height of each cam lobe.
- ★ If the cam height is less than the service limit for either lobe, replace the camshaft.

Cam Lobe Height

Service Limit: IN. 25.21 mm (0.993 in.)
EX. 25.46 mm (1.002 in.)

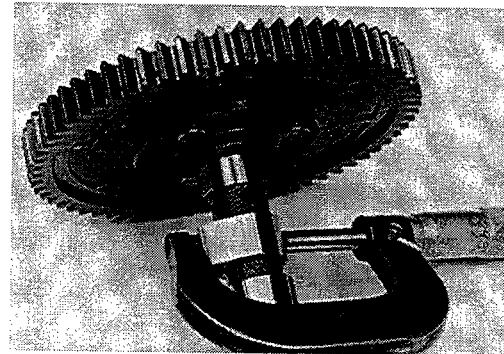

- With a micrometer, measure both camshaft journals at several points around the journal circumference.
- ★ If the journal diameter is less than the service limit, replace the camshaft.

PTO Side Journal Diameter

Service Limit: 15.907 mm (0.6263 in.)

Flywheel Side Journal Diameter

Service Limit: 15.917 mm (0.6267 in.)

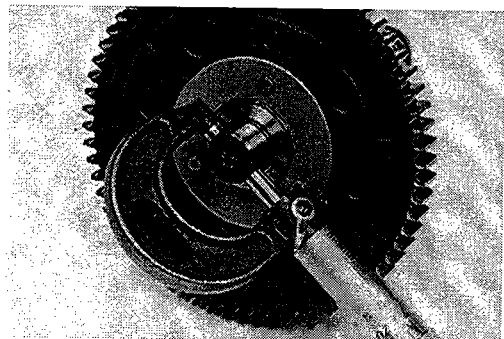

6-10 CAMSHAFT/CRANKSHAFT

- Measure the inside diameter of the camshaft bearing (A) on the crankcase at several points. This bearing is not replaceable. Replace the crankcase if the inside diameter more than the service limit.

Camshaft Bearing Inside Diameter

Service Limit: 16.068 mm (0.6326 in.)

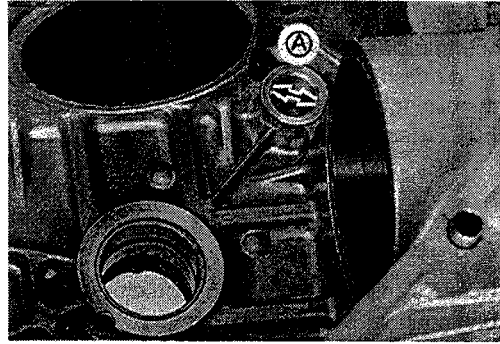

- Measure the inside diameter of the camshaft bearing (A) on the crankcase cover at several points.

This bearing is not replaceable. Replace the crankcase cover if the inside diameter is more than the service limit.

Camshaft Bearing Inside Diameter

Service Limit: 16.068 mm (0.6326 in.)

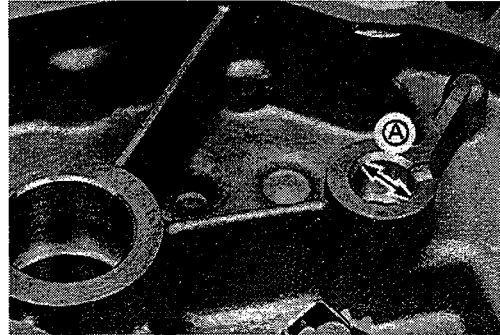

Crankshaft, Connecting Rod

Crankshaft, Connecting Rod Removal/Installation:

Connecting Rod Removal

- Remove the connecting rod during the piston removal (see Piston Removal in the Engine Top End chapter).

Connecting Rod Installation Notes

- See Piston Installation Notes in the Engine Top End chapter for assembling the piston onto the connecting rod and insert the assembly into the cylinder.
- Turn the crankshaft until the crankpin is lowest position.
- Apply engine oil to the bearing portion of each connecting rod big end and cap.
- Install each connecting rod big end onto the crankpin.
- Place the connecting rod caps over the crankpin so the pilot grooves (B) on the caps and rods are aligned.
- Be sure the large chamfers on the connecting rods facing toward each crank web.
- Coat a light film of oil on the threads of connecting cap bolts (A).
- Install cap bolts and tighten them to the specified torque (see Exploded View)

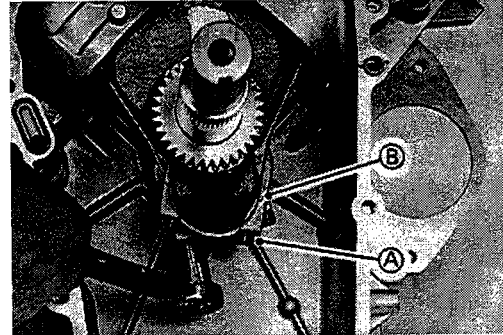

Crankshaft Removal/Installation Notes

- Remove
 - Flywheel
 - Camshaft
 - Connecting rod and piston assembly
- Pull the crankshaft out of the crankcase. Tap gently with a wooden or plastic mallet if necessary to loosen the crankshaft.
- Clean up the crankshaft and crankcase thoroughly, especially at the bearing contact surfaces.
- Pack some amount of high temperature grease into the oil seal on the crankcase.
- Apply engine oil to the journal and bearing.
- Carefully insert the crankshaft flywheel end into the main bearing and oil seal in the crankcase, if necessary, cover the key way on the crankshaft taper with a tape to avoid damaging these parts.
- Be sure to fit the woodruff key correctly on the crankshaft taper.

- A. Woodruff Key
- B. Crankshaft Taper
- C. Oil Seal

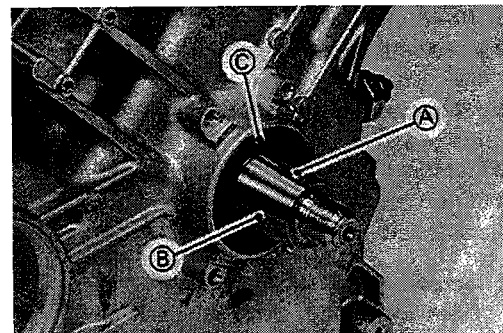

Crankshaft, Connecting Rod Inspection/Maintenance:

Cleaning/Inspection

- After removing, clean the crankshaft and connecting rods with a high flash-point solvent and dry them with compressed air.
- Inspect the teeth of the crankgear for pitting, fatigue cracks, burrs and evidence of improper tooth contact.
Replace the gear if necessary.
- Inspect the crankshaft and connecting rods especially at the bearing surfaces for wear, scratches, evidence of improper contact or other damages. Replace them if necessary.

Connecting Rod Bend/Twist

- Measure connecting rod bend.
 - Select an arbor of the same diameter as the connecting rod big end, and insert the arbor through the connecting rod big end.
 - Select an arbor of the same diameter as the piston pin and at least 100 mm long, and insert the arbor through the connecting rod small end.
 - On a surface plate, set the big-end arbor on V blocks.
 - With the connecting rod held vertically, use a height gauge to measure the difference in the height of the small end arbor above the surface plate over a 100 mm length to determine the amount of connecting rod bend.
- ★ If connecting rod bend exceeds the service limit, the connecting rod must be replaced.

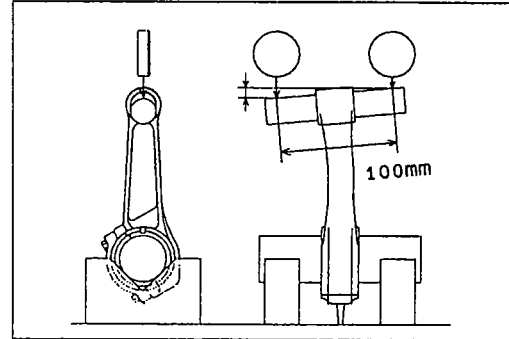

Connecting Rod Bend

Service Limit: 0.15/100 mm (0.006/3.94 in)

- Measure connecting rod twist.
 - With the big-end arbor still on the V blocks, hold the connecting rod horizontally and measure the amount that the small end arbor varies from being parallel with the surface plate over a 100 mm length of length of the arbor to determine the amount of connecting rod twist.
- ★ If connecting rod twist exceeds the service limit, the connecting rod must be replaced.

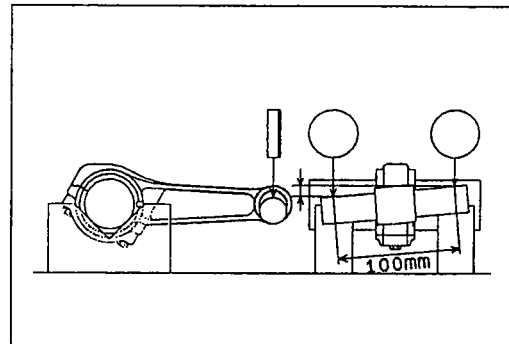

Connecting Rod Twist

Service Limit: 0.15/100 mm (0.006/3.94 in)

Connecting Rod Big End/Crankpin Width Wear

- Measure the connecting rod big end width (A) with a micrometer or dial caliper.
- ★ If the measurement is less than the service limit, replace the connecting rod.
- Measure the crankpin width (B) with a dial caliper.
- ★ If the crankpin width is more than the service limit, replace the crankshaft.

Connecting Rod Big End Width

Service Limit: 21.20 mm (0.83 in)

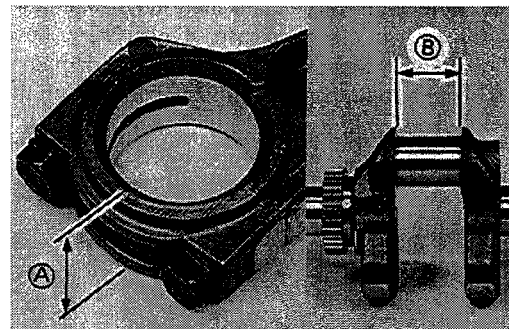

Crankpin Width

Service Limit: 44.5 mm (1.75 in)

Connecting Rod Big End Bearing/Crankpin Wear

- Place the connecting rod cap over its big end to align the pilot grooves on the cap and rod.
 - Coat a light film of oil on the thread of the cap bolts.
 - Install the cap bolts and tighten bolts to the specified torque (see Exploded View).
 - Measure the inside diameter (A) of big end at several points with a telescoping gauge or inside micrometer.
- ★ If the inside diameter is more than the service limit, replace the connecting rod with a new one.

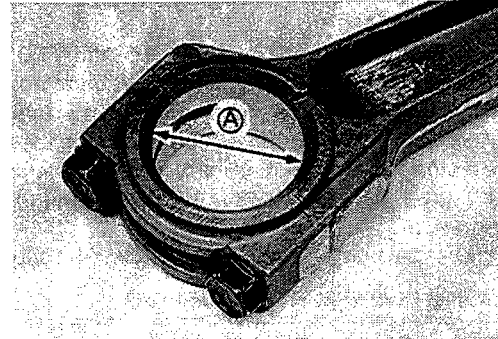

Connecting Rod Big End Inside Dia.

Service Limit: 34.055 mm (1.3407 in)

- Measure the crankpin diameter.
 - Use a micrometer to measure several points around the crankpin circumference.
- ★ If the crankpin diameter is less than the service limit, replace the crankshaft with a new one.

Crankpin Outside Diameter

Service Limit: 33.927 mm (1.3357 in)

A. Outside Diameter

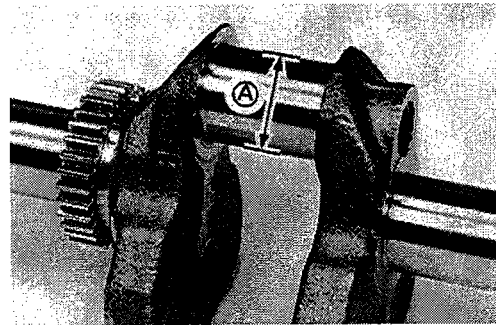

Crankshaft Runout

- Measure the crankshaft runout.
 - Set the crankshaft in a flywheel alignment jig or on V blocks gauge.
 - Set a dial gauge against both bearing journals.
 - Turn the crankshaft slowly to measure the runout. The difference between the highest and lowest dial gauge readings (TIR) is the amount of runout.
- ★ If the measurement exceeds the service limit, replace the crankshaft.

Crankshaft Runout

Service Limit: 0.05 mm (0.002 in) TIR

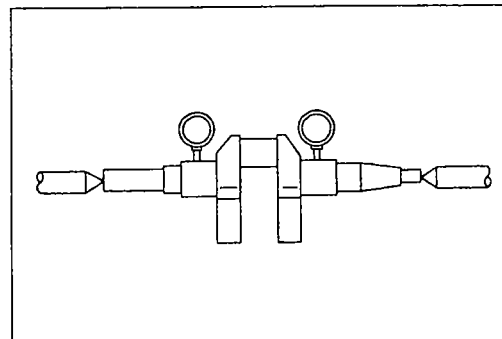

Crankshaft Main Journal/Wear

- With a micrometer, measure the both main journals at several points around the journal circumference.
- ★ If the journal diameter (A) is less than the service limit, replace the crankshaft with a new one.

PTO Main Journal Diameter

Service Limit: 33.909 mm (1.3350 in)

Flywheel Side Journal Diameter

Service Limit: 33.909 mm (1.3350 in)

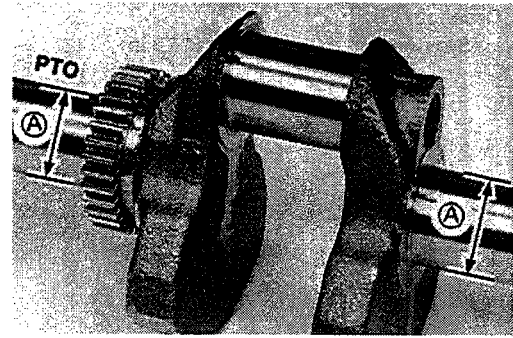

Crankpin Resizing

Crankpin can be to accept 33.5 mm (1.3189 in) dia under size connecting rod. The crankpin should be reground if the crankpin is so much undersize and so much scored that a lapping operation will prove unsatisfactory. Reground can be done by a reliable repair shop.

- Before sending the crankshaft, inspect the crankpin for cracks.
- ★ If any cracks, no matter how small, are found, the crankshaft must be rejected.
- The final finishing dimensions should be shown in the table.

Finishing Dimensional Specifications

1.	<u>33.480 to 33.467 mm</u> (1.318 to 1.3176 in)
2.	<u>2.30 to 2.70 mm</u> (0.09 to 0.11 in)
3.	<u>44.40 mm MAX</u> (1.748 in MAX)
4.	<u>34.000 to 33.950 mm</u> (1.3386 to 1.3366 in)

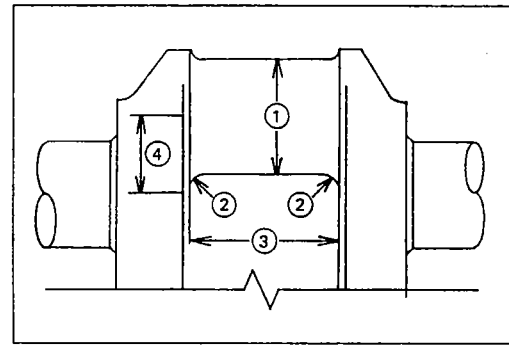

- The crankpin surface should be concentric and parallel to each other within 0.006 mm (0.0002 in.) full indicator reading.
- Finish the crankpin surface with a super finishing stone.

Electrical System

Table of Contents

Exploded View	7-2
Specifications	7-3
Special Tools	7-4
Wiring Diagram	7-5
Wire Harness	7-6
Precautions	7-9
Charging System	7-10
Alternator Rotor and Stator Removal	7-10
Alternator Stator (Charging Coil)	7-10
Alternator Rotor and Stator Installation	7-10
Charging System Operational Inspection	7-11
Stator Coil Resistance	7-11
Unregulated Stator Output	7-11
Regulator Resistance	7-12
Ignition System	7-13
Pulser Coil Removal	7-14
Installation Notes	7-14
Pulser Coil Resistance	7-14
Igniter Inspection	7-15
Ignition Coil Inspection	7-16
Spark Plug Cleaning and Inspection	7-16
Spark Plug Gap Inspection	7-17
Electric Starter System	7-18
Starter Motor Removal	7-18
Starter Motor Installation	7-18
Starter Solenoid and Circuit Test	7-18
Starter Motor Test	7-19
No-Load Starter Draw Bench Test	7-19
Starter Motor Disassembly	7-20
Starter Motor Assembly Notes	7-21
Starter Motor Brush Inspection	7-22
Brush Spring Inspection	7-23
Armature Inspection	7-23
Yoke Assembly Inspection	7-24
Pinion Clutch Inspection	7-25

Exploded View

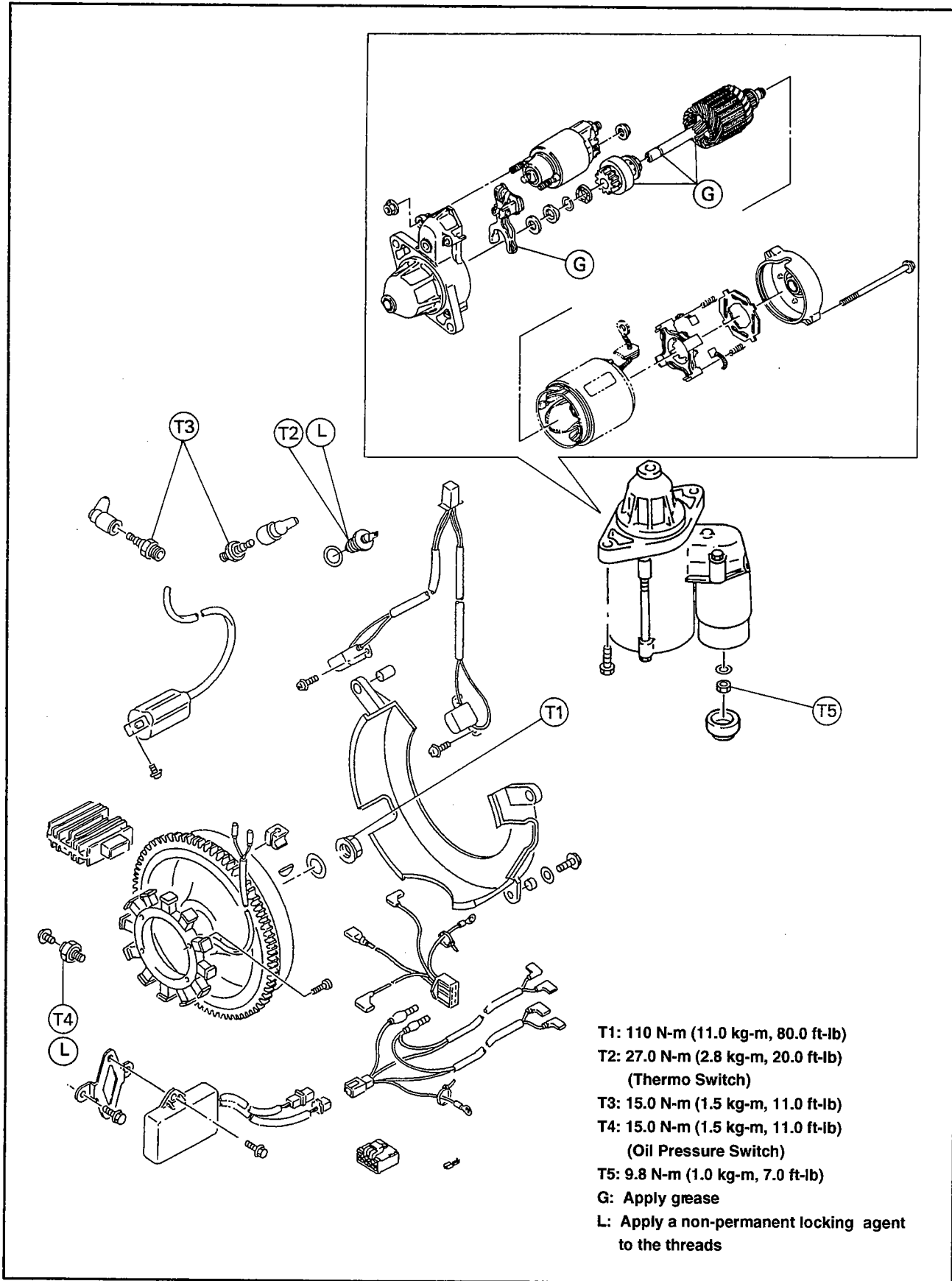

Specifications

Item	Standard	Service Limit
Charging System: Regulated output voltage Alternator stator coil resistance Unregulated stator output Regulator resistance	Battery voltage to 15V DC 0.11 to 0.18 Ω --- See charging system	--- --- 26VAC/3 000 rpm
Ignition System: Pulser Coil: Coil air gap Coil resistance Igniter resistance Ignition coil: Primary winding resistance Secondary winding resistance Spark plug Plug gap	 0.3 to 1.2 mm (0.012 to 0.05 in.) (not adjustable) 85 to 270 Ω See ignition system 3.4 to 4.6 Ω 10.4 to 15.6 k Ω NGK BMR4A 0.6 to 0.7 mm (0.024 to 0.028 in.)	 --- --- --- --- --- ---
Electric Starter System: Starter motor: Carbon brush length Commutator groove depth Commutator diameter Commutator runout	 10 mm (0.394 in.) 0.5 to 0.8 mm (0.02 to 0.031 in.) 28 mm (1.102 in.) ---	 6.0 mm (0.24 in.) 0.2 mm (0.008 in.) 2.7 mm (1.06 in.) 0.4 mm (0.016 in.)

7-4 ELECTRICAL SYSTEM

Special Tools

KAWASAKI Hand Tester

(P/N : 57001-1394)

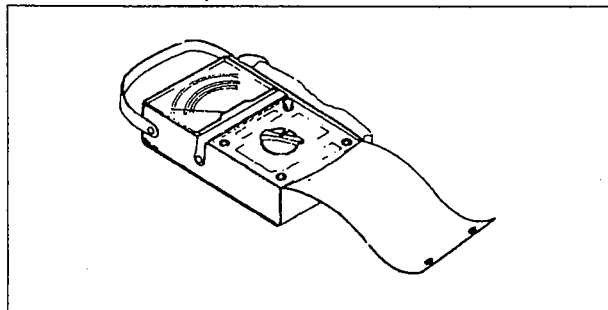

Wiring Diagram Revised

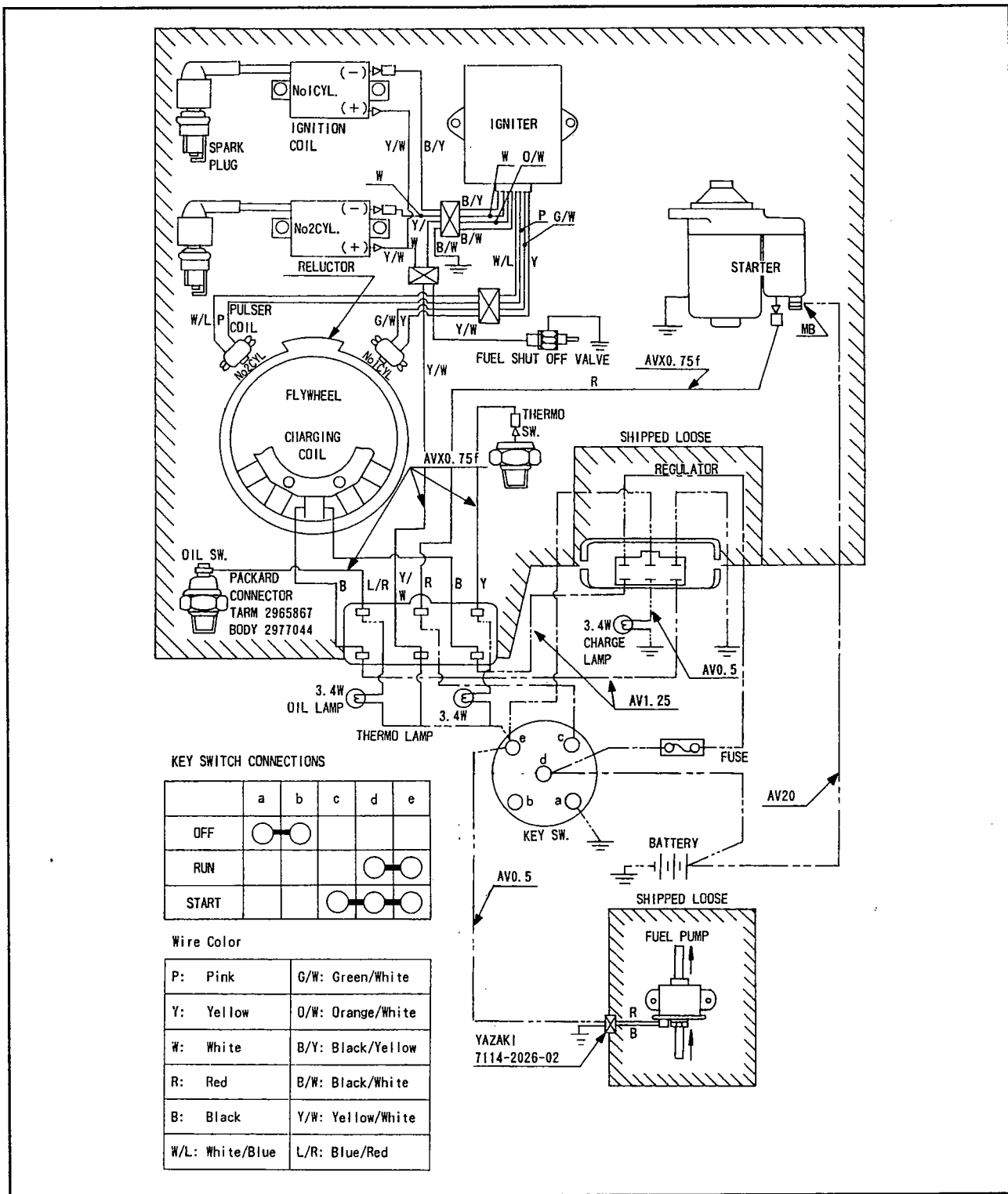

Note: PORTION SURROUNDED BY // shows KAWASAKI PROCUREMENT PARTS

Wire Harness

WIRE-HARNESS

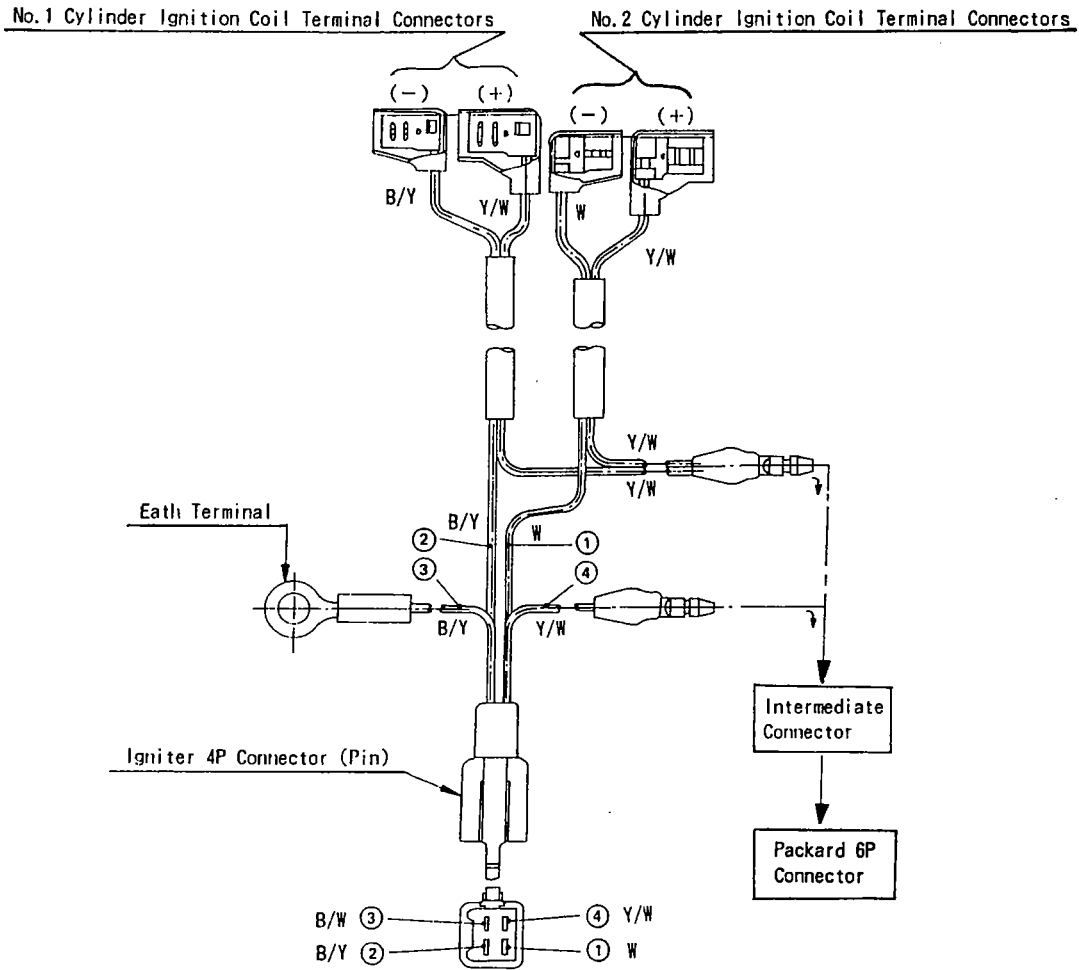

IGNITION COILS

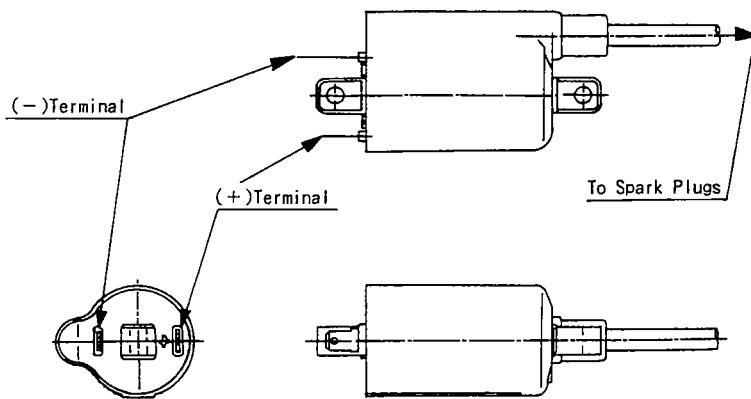

CHARGING COIL

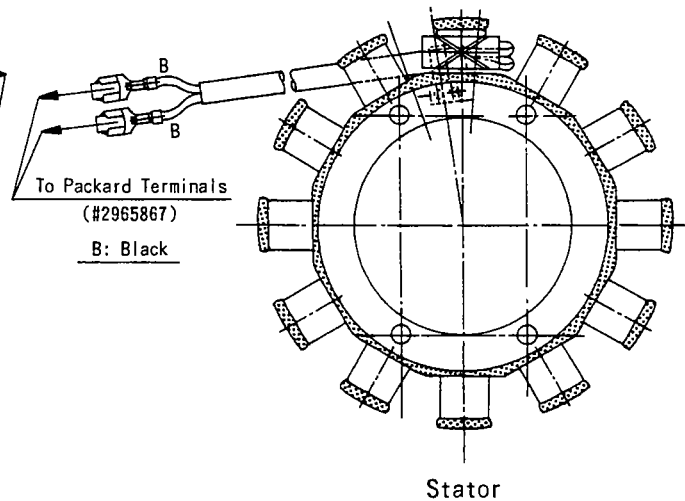

IGNITER

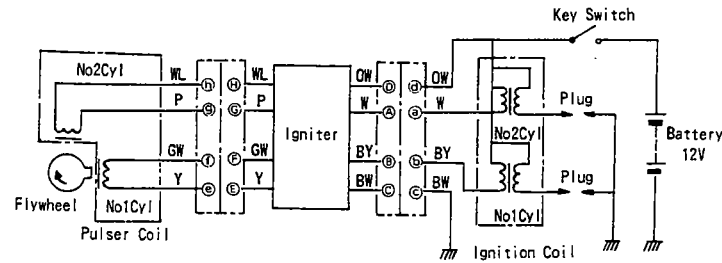
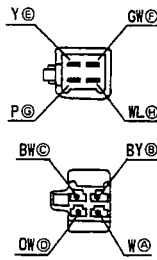
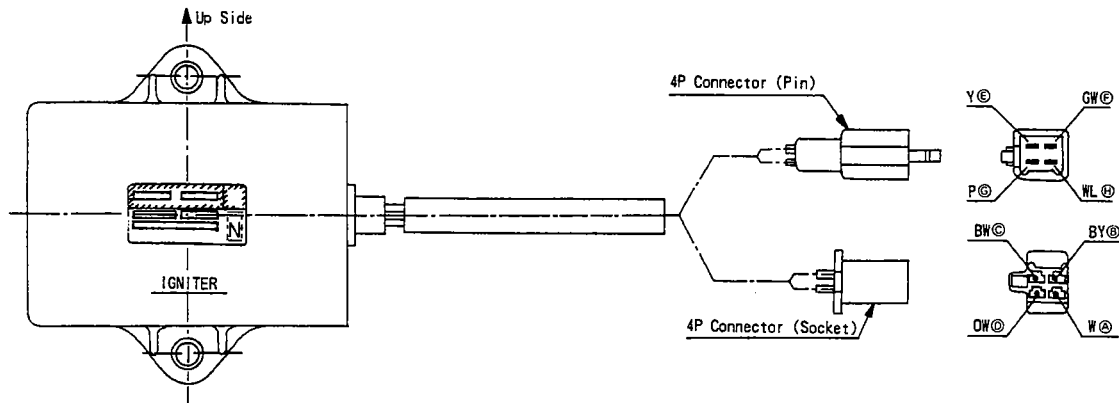

Wiring Diagram

PULSER COILS

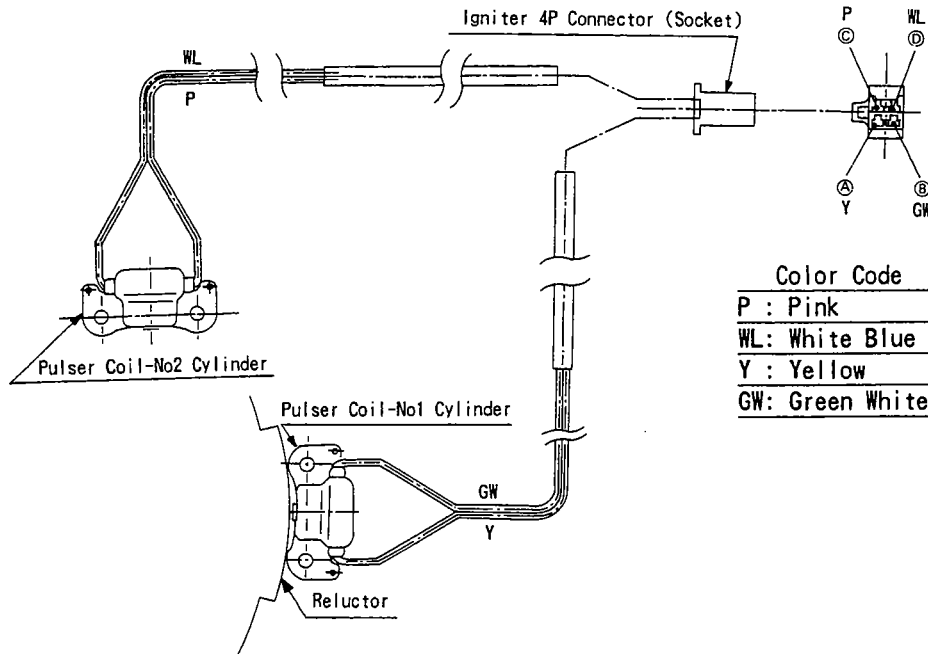

WIRE-HARNESS

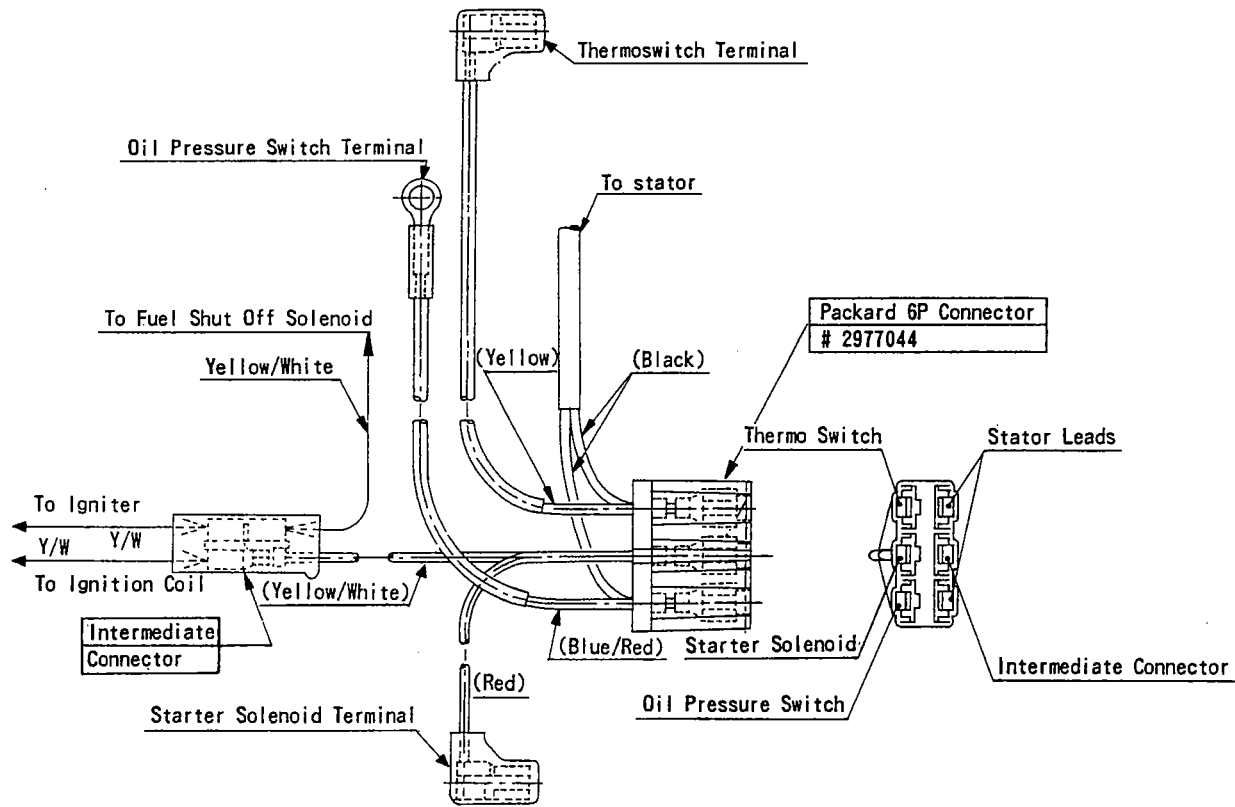

VOLTAGE REGULATOR

CHG Monitor Lamp (MAX): 12V-3.4W

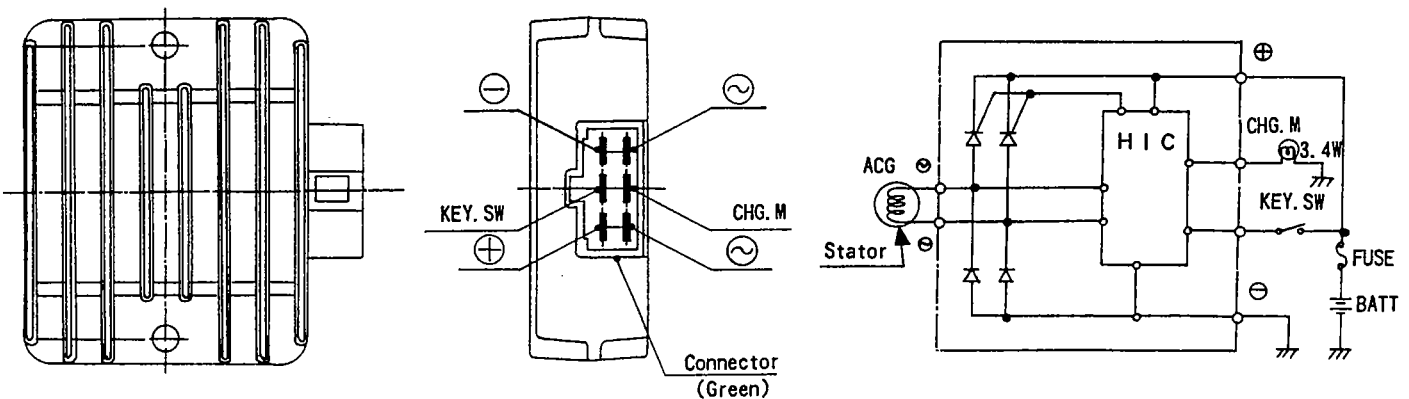

Precautions

There are a number of important precautions that are musts when servicing electrical systems. Learn and observe all the rules below.

- Do not reverse the battery lead connections. This will burn out the diodes in the electrical parts.
- Always check battery condition before condemning other parts of an electrical system. A fully charged battery is a must for conducting accurate electrical system tests.
- The electrical parts should never be struck sharply, as with a hammer, or allowed to fall on a hard surface. Such a shock to the parts can damage them.
- To prevent damage to electrical parts, do not disconnect the battery leads or any other electrical connections when the engine switch is on, or while the engine is running.
- Because of the large amount of current, never keep the engine switch turned to the start position when the starter motor will not turn over, or the current may burn out the starter motor windings.
- Take care not to short the leads that are directly connected to the battery positive (+) terminal to the chassis ground.
- Troubles may involve one or in some cases all items. Never replace a defective part without determining what CAUSED the failure. If the failure was brought on by some other item or items, they too must be repaired or replaced, or the replacement part will soon fail again.
- Make sure all connectors in the circuit are clean and tight, and examine wires for signs of burning, fraying, etc. Poor wires and bad connections will affect electrical system operation.
- Measure coil and winding resistance when the part is cold (at room temperature).
- Electrical Connectors:

Female Connectors

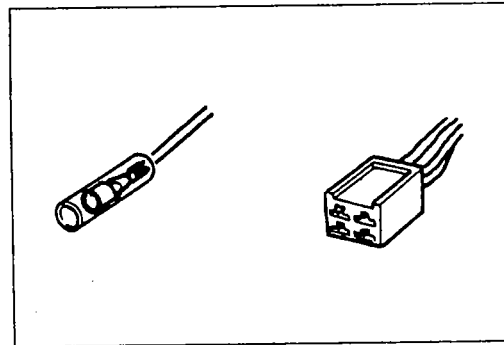

Male Connectors

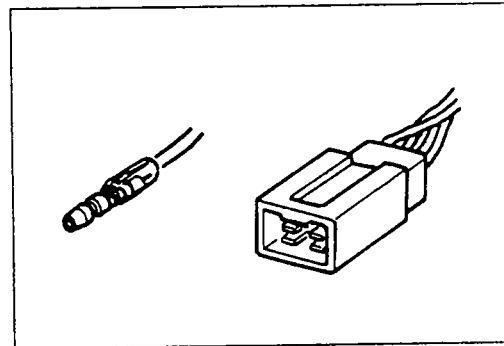

Charging System

Alternator Rotor and Stator Removal

- Remove the followings.
 - Radiator
 - Cooling Fan
 - Starter Motor
 - Pulser Coils
 - Fan Drive Sheave/Hub
- Hold the rotor (flywheel) with a suitable tools, remove the flywheel mounting nut.
- Using a flywheel puller, remove the flywheel.
 - A. Flywheel Nut

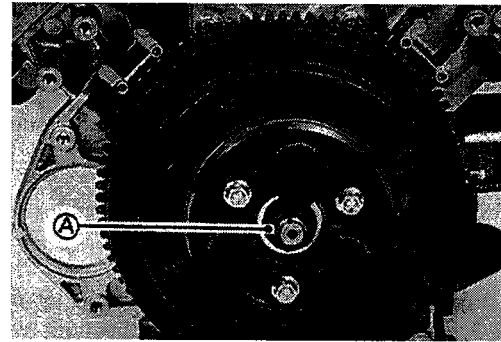

NOTE

- If a flywheel puller is not available, screw the flywheel mounting nut flush with the shaft end to prevent damaged shaft end threads and tap sharply and squarely on the nut to break the flywheel loose. Flywheel will loosen.
- A. Tap sharply and Squarely

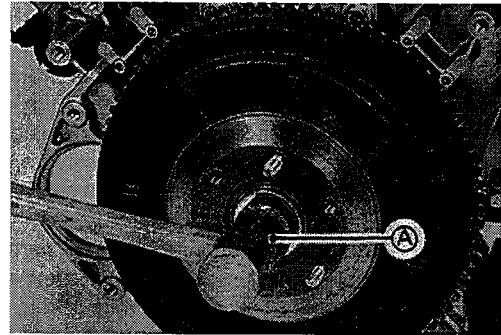

Alternator Stator (Charging Coil):

- Note the charging coil output leads position for reinstalling the charging coil.
- Unscrew the coil mounting screws and remove the charging coil.
 - A. Charging Coil Output Leads
 - B. Mounting Screws

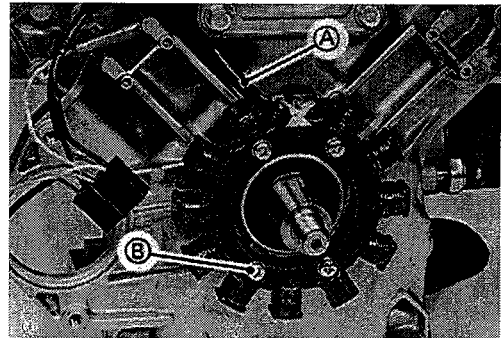

Alternator Rotor and Stator Installation

- Clean the inside of the flywheel and end of the crankshaft or the taper will not fit snugly.
- Fit the flywheel onto the crankshaft taper so that the woodruff key fits in the key way in the hub of the flywheel.
- Torque the following.
 - Alternator Rotor Nut
- Tighten the nut to the specified torque once, loosen it, and then retighten it to the specified torque (see Exploded View).
 - Alternator Stator
- To reset the charging coil core onto the mounting flanges, firmly push the charging coil assembly against the mounting flanges and tighten the screws securely.
 - A. Mounting Flanges
 - B. Mounting Screws

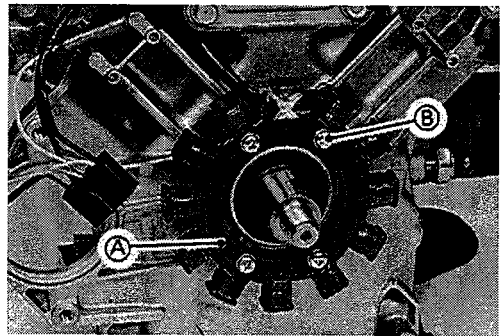

Charging System Operational Inspection

- Check battery condition.

NOTE

○ Always check battery condition before condemning other parts of the charging system. The battery must be fully charged in order to conduct accurate charging system tests.

- Warm up the engine to bring the components up to their normal operating temperatures.
- Measure regulated output voltage at various engine speeds.
- Connect a voltmeter across the battery terminals.
- ★ The readings should show nearly battery voltage when the engine speed is low, and as the engine speed rises, the readings should also rise. But they must stay within the specified range.
- ★ If the output voltage is much higher than the specification, the regulator is defective, or the regulator leads are loose or open.
- ★ If the output voltage does not rise as the engine speed increase, the regulator is defective or the alternator output is insufficient for the loads.

**Regulated Output Voltage
Battery Voltage to 15 VDC**

Stator Coil Resistance

- Disconnect the PACKARD 6P connector.
- Measure the stator coil resistance.
- Connect the KAWASAKI hand tester between stator pins.

**Stator Coil Resistance
0.11 to 0.18 Ω**

- ★ If the tester does not read as specified, replace the alternator stator.
- ★ If the coil has normal resistance, but the voltage inspect showed the alternator to be defective; the rotor magnets have probably weakened, and the rotor must be replaced.
- Check for continuity between each stator pin and ground. There should be no continuity (infinite ohm).
- ★ If the stator coil fails any of these tests, replace the coil with a new one.

1. To Stator
2. PACKARD 6P Connector

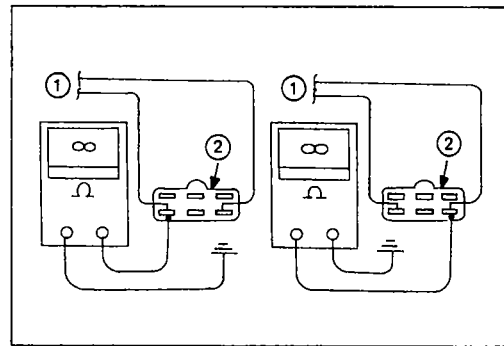
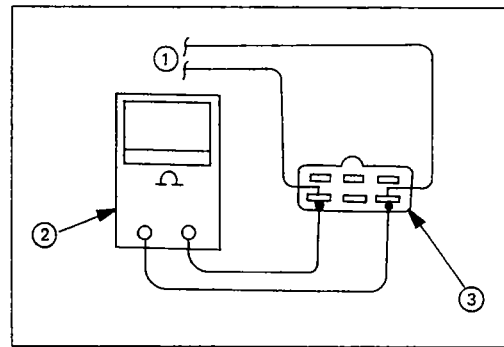

Unregulated Stator Output

- Disconnect the PACKARD 6P connector.
- Connect KAWASAKI hand tester to the stator pins.
- Start the engine. Run the engine at the 3000 rpm speed.
- Voltage reading should be minimum 26 VAC/3000 rpm.
- ★ If the AC voltage reading is less than the specification, replace the stator.

**Unregulated Stator Output (MIN)
26 VAC/3000 rpm**

1. PACKARD 6P Connector
2. To Stator
3. Hand Tester

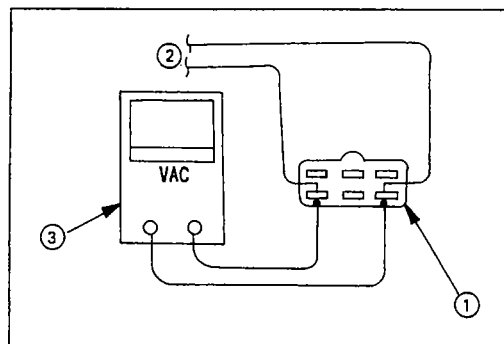

7-12 ELECTRICAL SYSTEM

Regulator Resistance

- Set the KAWASAKI Hand Tester selector switch to the R x 100Ω position.
- Connect the test leads to the points shown on the chart and read the resistance.
- ★ If the resistance is not as specified, replace the regulator.

NOTE

○ This voltage regulator is an open type one.

- A. Regulator
- B. 6P Connector

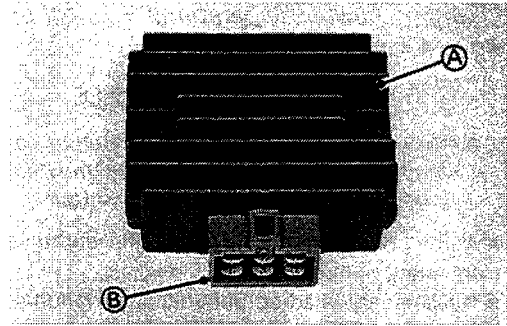

Range: R x 100Ω By KAWASAKI TESTER

(-) TESTER (+)	~ 1	~ 2	+	-	Key.SW	CHG.M
~ 1	--	50kΩ ~ 1MΩ	∞	500Ω ~ 5kΩ	1kΩ ~ 20kΩ	1kΩ ~ 20kΩ
~ 2	50kΩ ~ 1MΩ	--	∞	500Ω ~ 5kΩ	1kΩ ~ 20kΩ	1kΩ ~ 20kΩ
+	∞	∞	--	∞	∞	∞
-	50kΩ ~ 1MΩ	50kΩ ~ 1MΩ	∞	--	500Ω ~ 10kΩ	500Ω ~ 10kΩ
Key.SW	∞	∞	∞	∞	--	∞
CHG.M	50kΩ ~ 1MΩ	50kΩ ~ 1MΩ	∞	500Ω ~ 5kΩ	1kΩ ~ 20kΩ	--

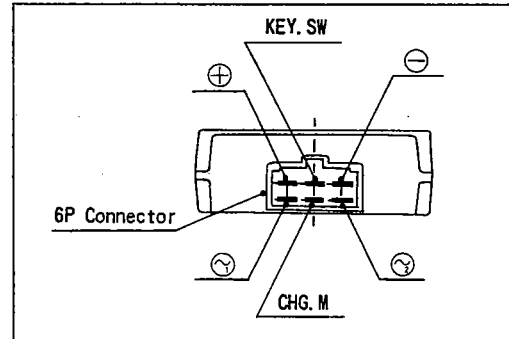

NOTE

○ Resistance value may vary with individual meters.

Ignition System

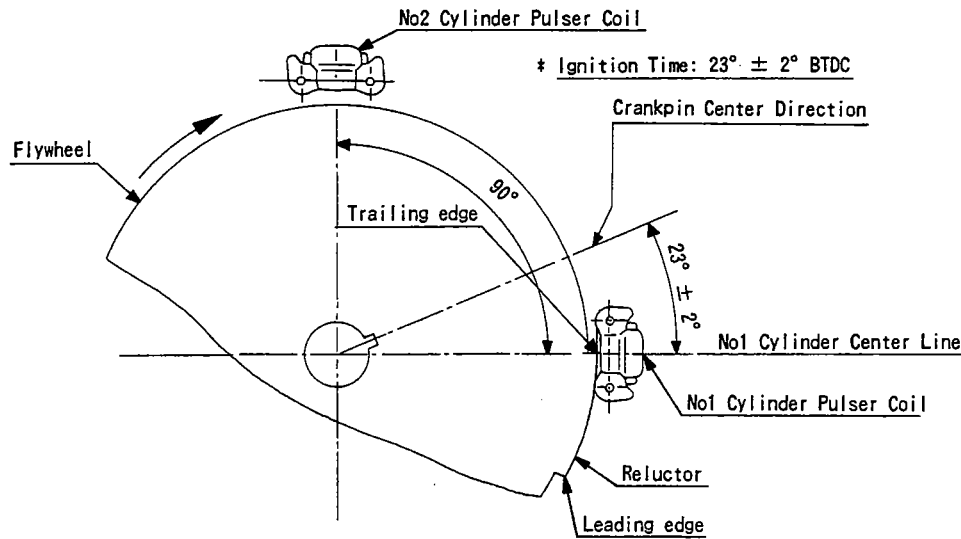
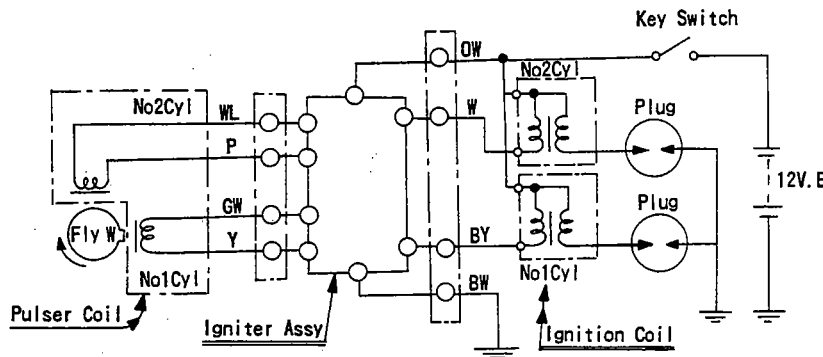

Transistor controlled battery ignition system is used in this engine. This ignition system is essentially a battery-ignition coil system where the battery supplies the current to the primary circuit in the system. This ignition system is transistorized and controls the current for the primary circuit by use of a electronic switching unit integrated into the igniter. The switching unit is triggered by the pulser coils (pick up coils) on each cylinder and contains no mechanical parts. This system consists of the following components.

- Ignition coil units
- Igniter (ignition Control Unit)
- Flywheel reductor
- Pulser coils (pick up coils)
- 12 V Battery
- Spark plugs

As the starter turns the flywheel, the reductor in the flywheel runs past the pulser coils, this creates a magnetic field in the pulser coils and close the switching unit in the igniter and allow the current flow through the primary circuit in the ignition coils.

As the flywheel turns, the trailing reductor passes under pulser coils, opening switching unit in the igniter and causing the primary coil current to stop suddenly. This creates an induced high voltage in a secondary coil windings, which fire the spark plugs.

Each spark plug fires every time the piston rises. When a spark does jump across the electrodes during the exhaust stroke, it will not affect on engine operation, since there is no compression and no combustible fuel/air mixture. The transistor controlled ignition system contains no mechanical parts, no wear occurs and no periodic maintenance is required except for the spark plug.

7-14 ELECTRICAL SYSTEM

Pulser Coil Removal

- Remove:
 - Radiator and its Brackets
 - Flywheel Cover
 - Cooling Fan and its Brackets
- Disconnect the wire ties.
- Unscrew the pulser coil mounting screws and pull the pulser coils out of the cylinder block and leave them there.
- Disconnect the 4P coupler of the pulser coil leads end.
- Take off the pulser coils and its wire leads together.

- A. Pulser Coils
- B. Wire Tie
- C. Mounting Screws

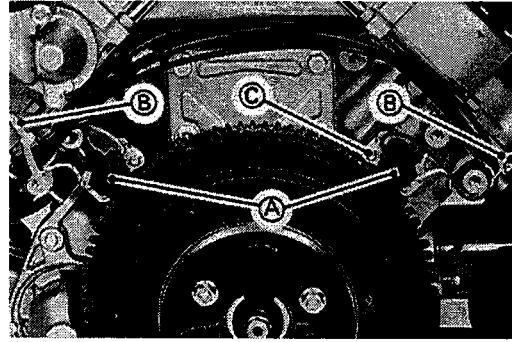

Installation Notes

- Installation is the reverse of removal.
- The pulser coils are mounted in a fixed position on each cylinder. No adjustment of the coil air gaps are required.
- When installing the coils on each cylinder, do not take the coil for another noting the wire color (see Wiring Diagram in this chapter).

Pulser Coil Air Gap (STD)

0.3 to 1.2 mm (0.012 to 0.05 in.)

Pulser Coil Resistance

- Set the KAWASAKI hand tester selector switch to the R x 1 Ω position.
- Connect the test leads to the points shown on the chart and read the resistance.
- ★ If the resistance is not as specified, replace the pulser coil,

Resistance Between	
[A] and [B]	[C] and [D]
85 Ω to 270 Ω	85 Ω to 270 Ω
←-----R x 1 Ω-----→	

NOTE

○ Resistance value may vary with individual meters.

Wire Color

- Y : Yellow
- GW : Green/White
- P : Pink
- WL : White/Blue

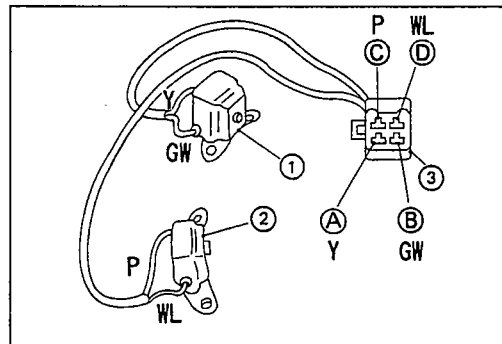

Igniter Inspection

- Remove the igniter.
- Unfasten the igniter lead connectors.
- Unscrew the mounting screws and remove the igniter.

- A. Igniter
- B. Lead Connectors (4P Couplers)
- C. Mounting Screws

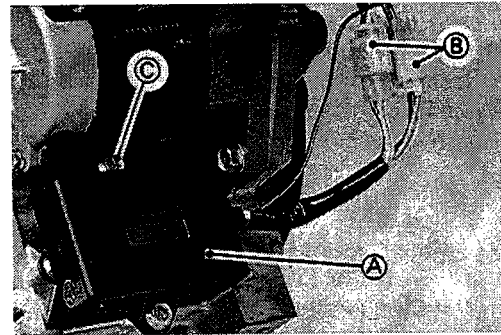

- To inspect the igniter resistance, perform the following.
- Set the KAWASAKI hand tester selector switch to the R x 1 kΩ position.
- Connect the test leads to the points shown on the chart and drawing and read the resistance.
- ★ If the meter readings are not as specified, replace the igniter.

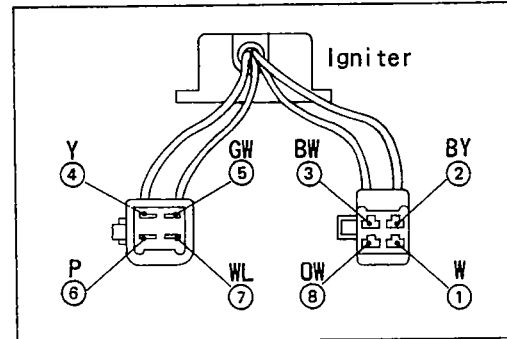

CAUTION

Use only Kawasaki hand tester (special tool:57001-1394) for this test. A tester other than the Kawasaki hand tester may show different readings.

If a megger or a meter with a large-capacity battery is used, the igniter will be damaged.

Meter Range : kΩ
Ambient Temperature (20 °C)

kΩ		Tester (+) Terminal (Red)							
Terminal		1	2	3	4	5	6	7	8
(-)*	1	-	∞	1 ~ 8kΩ	4 ~ 16	2 ~ 8	4 ~ 16	2 ~ 8	2 ~ 10
	2	∞	-	1 ~ 8	4 ~ 16	2 ~ 8	4 ~ 16	2 ~ 8	2 ~ 10
	3	∞	∞	-	1 ~ 6	0	1 ~ 6	0	0.5 ~ 2
	4	∞	∞	1 ~ 6	-	0	3 ~ 12	1 ~ 6	2 ~ 8
	5	∞	∞	0	1 ~ 6	-	1 ~ 6	0	0.5 ~ 2
	6	∞	∞	1 ~ 6	3 ~ 15	0.5 ~ 2	-	1 ~ 6	1 ~ 6
	7	∞	∞	0	1 ~ 6	2 ~ 8	1 ~ 6	-	0.5 ~ 2
	8	∞	∞	0.5 ~ 2	2 ~ 8	0.5 ~ 2	2 ~ 8	0.5 ~ 2	-

(-)*: Tester (-) Terminal (Black)

Wire Color	
W:	White
BY:	Black/yellow
BW:	Black/White
Y:	Yellow
GW:	Green/White
P:	Pink
WL:	White/Blue
OW:	Orange/White

Ignition Coil Inspection

- Remove the ignition coils.
- Disconnect the plug caps.
- Disconnect the primary coil lead terminals.
- Unscrew the mounting bolts and take off the ignition coils.

- A. Ignition Coils
 - B. Plug Caps
 - C. Mounting Bolts
 - D. Primary Coil Lead Terminals
- (Not Cylinder's Ignition Coil Shown)

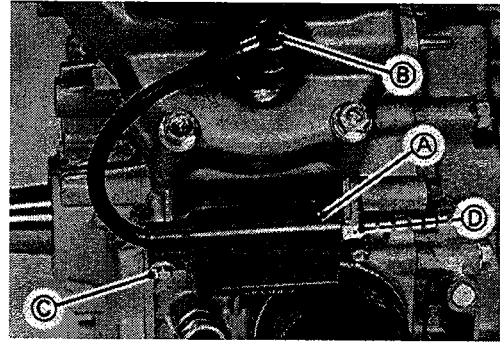

- Unfasten the plug cap from the high tension lead.
- Set the KAWASAKI hand tester selector switch to the specified range.
- Connect the test leads to the points shown on the chart and drawing and read the resistance. If the meter reading falls within the values shown in the chart, the coil is functioning properly.

Resistance Between	
[A] and [B]	[A] and [C]
3.4 Ω to 4.6 Ω	10.4 Ω to 15.6 kΩ
←----- R x 1 Ω -----→	←----- R x 1 kΩ -----→

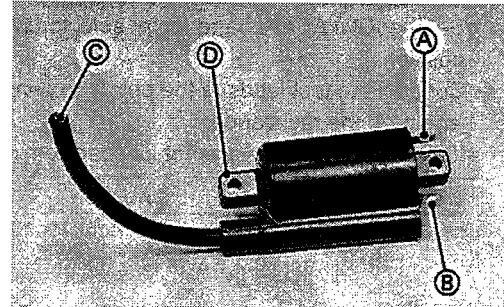

Resistance Between	
[A (or [B])] and [D]	[C] and [D]
∞	∞
←----- R x 1 kΩ -----→	

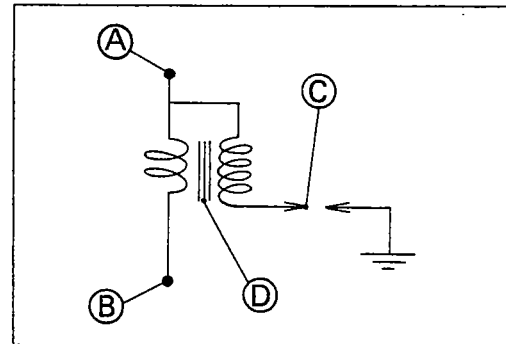

- ★ If the meter does not read as specified, replace the coil.
- ★ If the meter reads as specified, the ignition coil windings are probably good. However, if the ignition system still does not perform as it should after all other components have been checked, replace the coil with one known to be good.
- Check the spark plug lead for visible damage.
- ★ If the spark plug lead is damaged, replace the coil.

Spark Plug Cleaning and Inspection

- Carefully pull the plug cap from the spark plug, and remove the spark plug.
- ★ If the plug is oily or has carbon built up on it, clean the plug using a high flash-point solvent and a wire brush or other suitable tool.
- ★ If the spark plug electrodes are corroded or damaged, or if the insulator is cracked replace the plug. Use the standard spark plug or its equivalent.

- 1. Insulator
- 2. Center Electrode
- 3. Plug Gap
- 4. Side Electrode

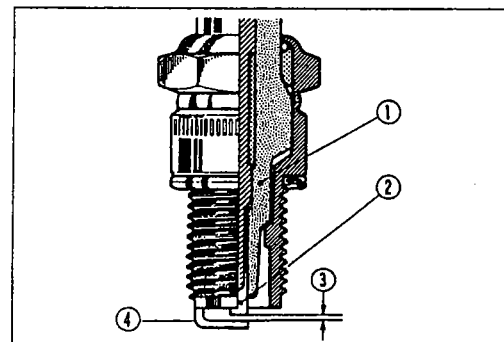

Spark Plug Gap Inspection

- Measure the gap with a wire-type thickness gauge.
- ★ If the gap is incorrect, carefully bend the side electrode with a suitable tool to obtain the correct gap.

Spark Plug Gap

Standard: 0.6 to 0.7 mm (0.024 to 0.028 in)

7-18 ELECTRICAL SYSTEM

Electric Starter System

Starter Motor Removal

- Disconnect the wires shown (A).
- Remove the mounting bolts (C) and pull the starter motor from the engine with the switch lead (B) attached.

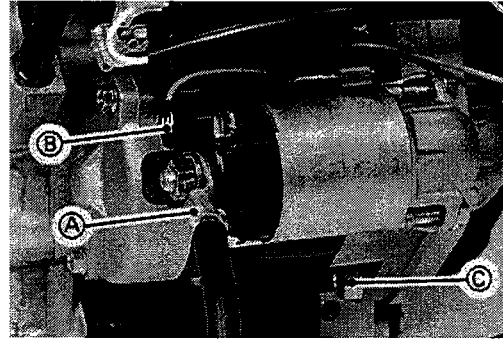

Starter Motor Installation

- Clean the starter motor and engine mounting flanges to ensure good electrical contact and tighten the mounting bolts to the specified torque (see Exploded View).

Starter Solenoid and Circuit Test

NOTE

○ Before this test, be sure the battery is fully charged.

- Disconnect the starter motor lead (A) from the solenoid terminal as shown and keep the lead away from the solenoid terminal.

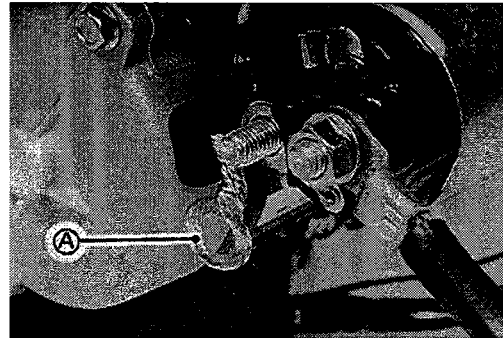

- Measure the continuity of the solenoid when activated.
- Set the hand tester selector switch to the $R \times 1 \Omega$ position and connect the leads across the large terminals (A) as shown.
- Turn the engine switch to the START (II) position and read the meter.
- ★ If the solenoid does not click or if the meter reads more than 0Ω the solenoid is faulty. Replace it.
- ★ If the solenoid makes a single clicking sound, the meter reads 0Ω and the pinion gear moves outward the solenoid and the rest of the starter circuit is good.
- ★ If solenoid clicks once but the meter does not read 0Ω , the solenoid is faulty. Replace it.
- ★ If the solenoid does not click at all, proceed with the following.
- Disconnect the switch lead (A) shown.

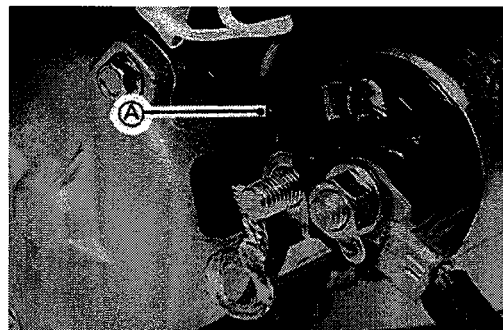
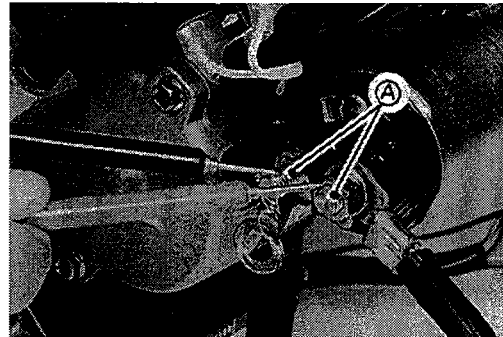

- Set the hand tester to the $R \times 1 \Omega$ position and connect the leads as shown.
- ★ If the meter does not read close to 0Ω , the solenoid is faulty. Replace it.
- ★ If the meter reads close to 0Ω , the solenoid may be good. Check the voltage to the solenoid from the engine switch.
 - A. Switch Terminal
 - B. To Ground

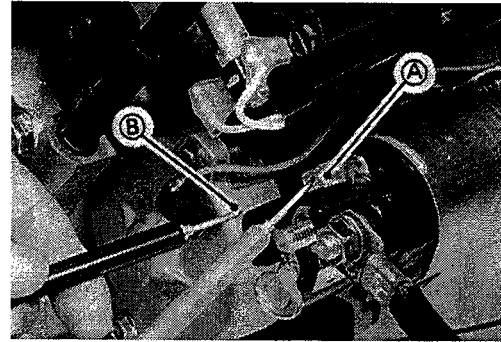

- Set the hand tester selector switch to the 25 VDC position and connect it as shown.
- Turn the engine switch to the START (II) position and read the meter.
- ★ If the meter reads battery voltage, the circuit is good. If the solenoid would not click in the previous test, it is faulty. Replace it.
- ★ If the meter reads much less than battery voltage or no voltage at all, either the wiring or the engine switch is bad. Check the engine switch or the wiring for damaged or broken wires and replace as required.
 - A. Switch Lead Connector
 - B. To Ground

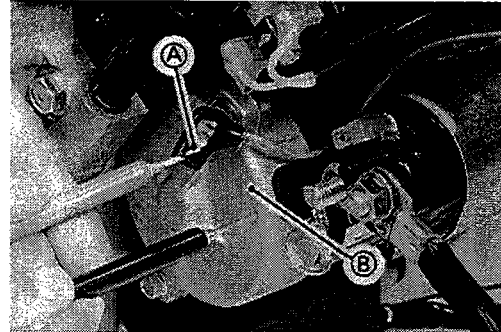

Starter Motor Test

CAUTION

Be careful not to deform the starter motor body when holding it with a vice.

- Remove the starter motor.
- Hold the starter motor with a vice as shown.
- Connect the first jumper cable to the battery (+) terminal and the other end of the cable to the starter motor terminal (A) on the solenoid.
- Connect the second jumper cable to the battery (-) terminal.
- Touch the starter body with the other end of the second jumper cable intermittently for one second intervals.
- The pinion should rotate freely.
- ★ If the pinion does not rotate freely, replace the starter motor.

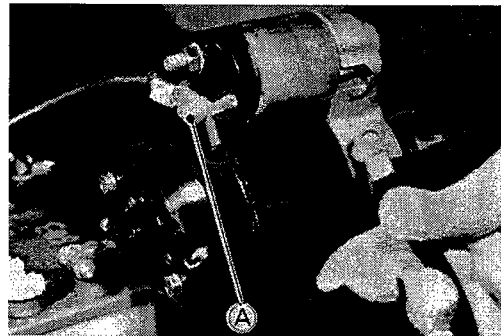

No-Load Starter Draw Bench Test

Needed for the test are;

- A tachometer capable of reading 15 000 r/min (rpm.)
- 12 V, 32 AH battery or more.
- An ammeter capable of reading 100 A.

▲WARNING

Battery electrolyte is poisonous and corrosive. It is injurious to eyes, skin and clothing. Handle it carefully.
If electrolyte is spilled, flush immediately with a solution of one part baking soda to four parts water.

7-20 ELECTRICAL SYSTEM

- Connect the starter motor, battery and ammeter as shown.

NOTE

○ *Starter motor should not be loaded. The test should be quickly conducted, as the rating is 30 seconds.*

- Active the starter motor. The starter motor in good condition will be within following specifications.

Terminal Voltage	11.5 V
Starter Motor RPM	6 000 (MIN)
Current Draw (A)	50 (MAX)

- ★ If not, check for the following and correct if necessary.

- A binding or seizing condition in the starter motor bearings.
- Starter Motor brushes sticking in the brush holders.
- A dirty or worn armature commutator or brushes.
- A shorted, open, or grounded armature or field coil.
- A defective starter motor switch.

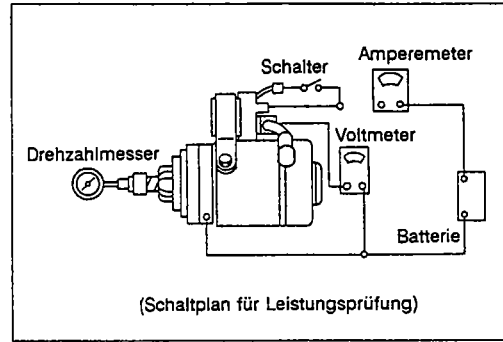

Starter Motor Disassembly

- Pull back the rubber boot and remove the lead (A) from the starter motor to the solenoid.

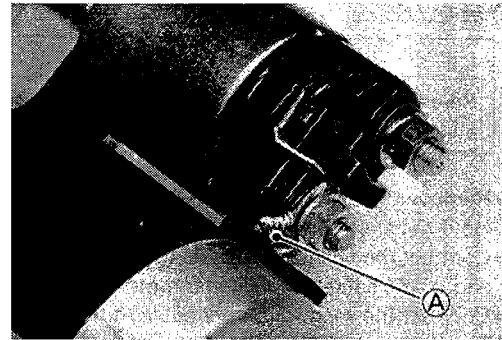

- Unscrew the mounting nuts (A) and remove the solenoid assembly (B).

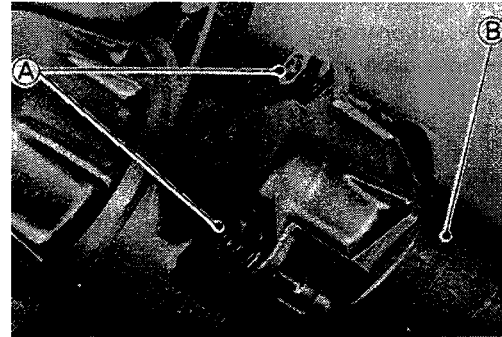

- Pull the rubber insert from the starter motor and remove the pinion gear cover as shown.
- Slip the actuating arm from the pinion gear.

- | | |
|------------------|----------------------|
| A. Through Bolts | C. Pinion Gear Cover |
| B. Rubber Insert | D. Actuating Arm |

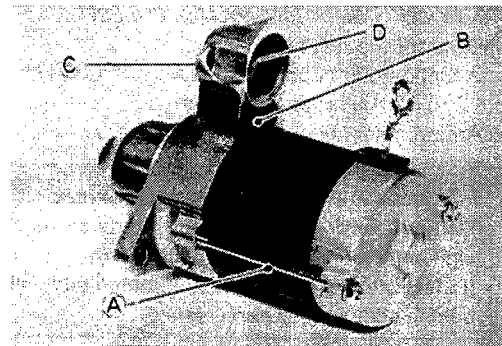

- Pull the armature from the yoke.

A. Armature
B. Thrust Washer
C. Front Stopper

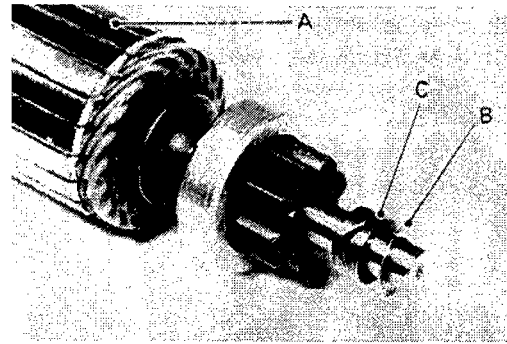

- Slide the thrust washer from the front of the shaft.
- Separate the front and rear stoppers each other using a screw driver and remove the front stopper.
- Push the rear stopper down the shaft and remove the snap ring.
- Slide the stopper and pinion gear from the armature shaft.

A. Thrust Washer
B. Front Stopper
C. Snap Ring
D. Rear Stopper
E. Pinion Gear

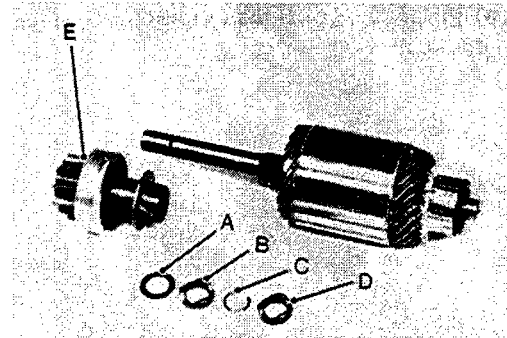

- Gently pull the end cover from the yoke and remove the insulator (A).

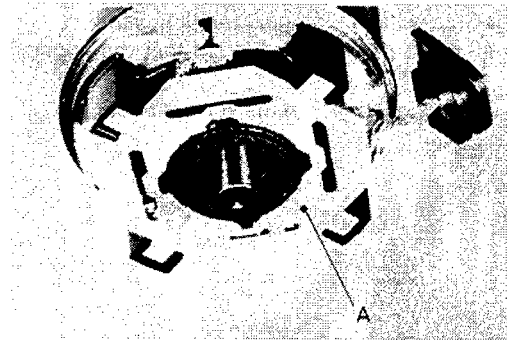

- Using a needle nose pliers, remove the brush springs from the brush holder.
- Separate the brushes from the holder and remove the holder from the yoke.

A. Brush Spring
B. Brush Holder
C. Brush
D. Yoke

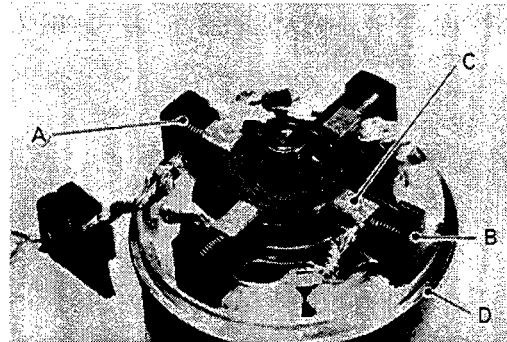

Starter Motor Assembly Notes

- Apply a small amount of grease to the armature shaft (A) as shown.
- Do not reuse the snap ring (B). Replace it with a new one.

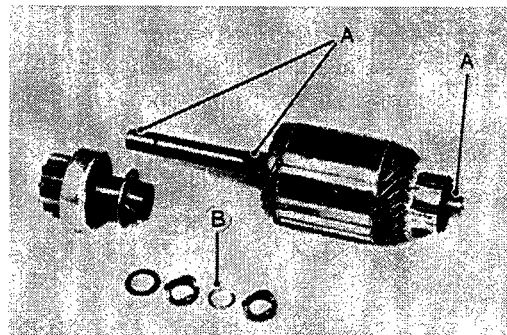

- Inspect the rubber insert (B) and/or boot (A) for visible damage.
- ★ If they are damaged, replace them.

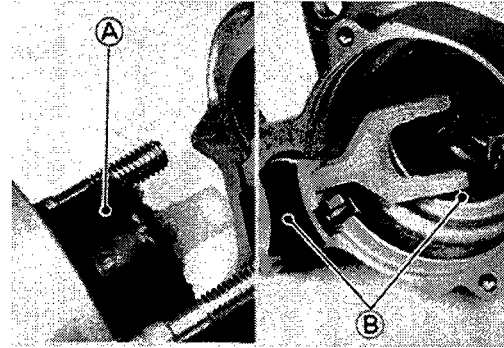

- Fit the notch (A) in the (-) lead grommet onto the projection (B) on the yoke.

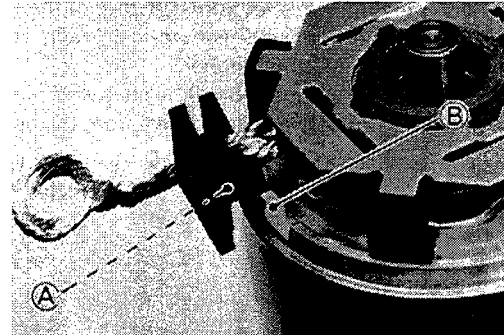

- Grease the pinion gear fork fingers.
- Set the pinion gear fork so that the fingers fit into the groove in the gear.
- Fit the notch (A) in the yoke onto the projection (B) on the pinion gear fork.

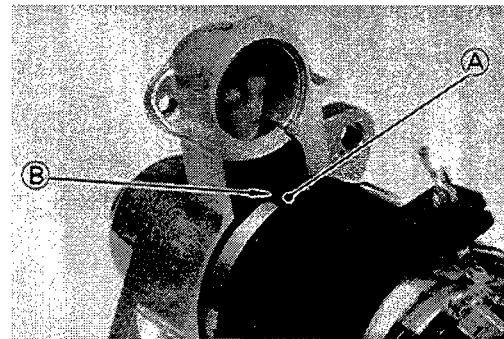

- Engage the hook (A) on the starter solenoid with the hook (A) on the pinion gear fork.

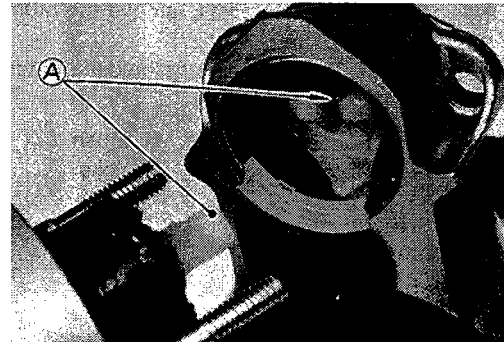

Starter Motor Brush Inspection

- Measure the overall length of each brush (A).
- ★ If the brushes are shorter than the service limit, replace them.

Brush Length

Service Limit: 6.0 mm (0.24 in)

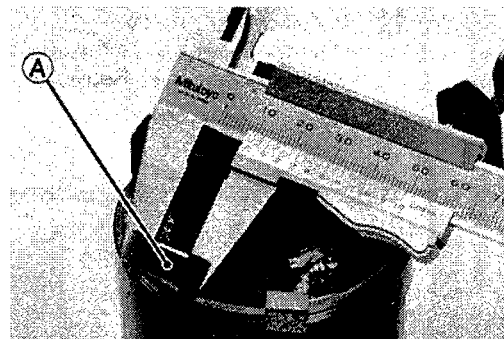

Brush Spring Inspection

- Inspect the brush springs for pitting, cracks, rusting and burrs. Replace the spring if necessary.
- Inspect the springs for weakened conditions and distortion. Replace the springs if necessary.
- ★ If the brush springs are able to press the brushes firmly into place, they may be considered serviceable. If they cannot, replace them.

Armature Inspection

- Inspect the surface of the commutator.
- ★ If it is scratched or dirty, polish it with a piece of very fine emery cloth, and clean out the grooves.

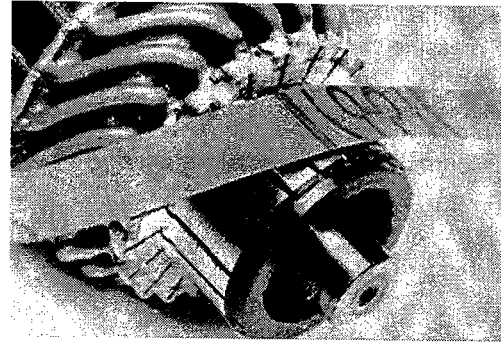

- Measure the depth of the grooves between the commutator segments.
- ★ If the grooves are shallower than the specified limit, undercut the insulating material to the standard depth 0.5 to 0.8 mm (0.012 to 0.031 in) using a thin file.
- ★ If the grooves are only dirty, clean them carefully.

Commutator Groove Depth Limit
Less than 0.2 mm (0.008 in)

- | | |
|------------|----------------------------|
| 1. Bad | 4. 0.2 mm (0.008 in) limit |
| 2. Segment | 5. Mica |
| 3. Good | |

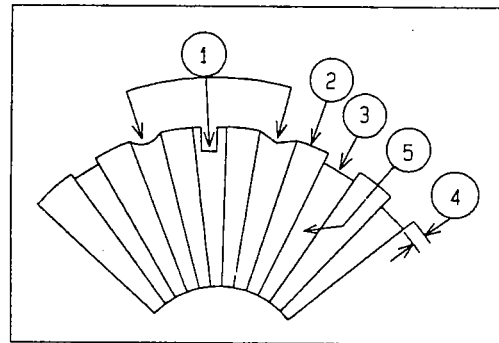

- Measure the commutator outside diameter at several points.
- ★ If the diameter is less than the service limit, replace the armature with a new one.

Commutator Outside Diameter
Service Limit: 27 mm (1.06 in)

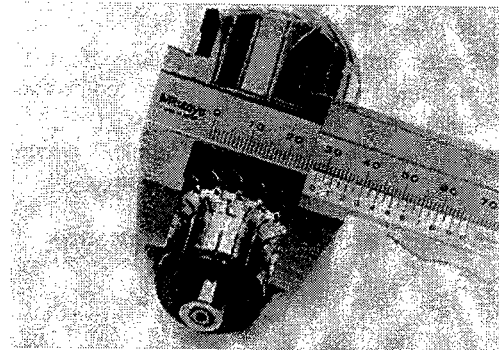

- Support the armature in an alignment jig at each end of the shaft as shown. Position a dial indicator perpendicular to the commutator.
- Rotate the armature slowly and read the commutator runout.
- ★ If runout is more than the service limit, turn down the commutator or replace the armature with a new one.

Commutator Runout
Service Limit: 0.4 mm (0.016 in)

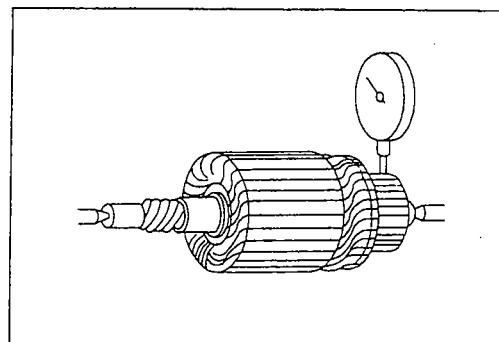

7-24 ELECTRICAL SYSTEM

- Measure the armature winding resistance.
- Set the hand tester selector switch to the R x 1 Ω position and check the resistance between each segment and all the others,
- ★ If the resistance is too high or even infinite, the armature winding has an open circuit. Replace the starter motor.

Armature Winding Resistance

Close to 0 Ω

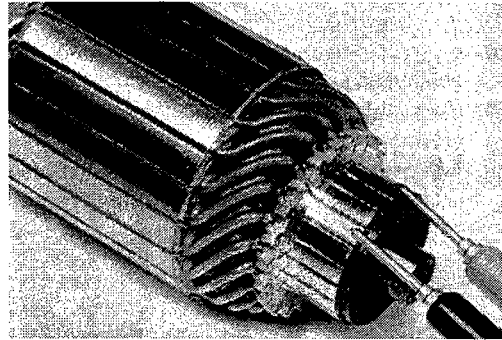

- Set the hand tester selector switch to the R x 1k Ω position and measure the resistance between the commutator and the armature shaft.
- ★ If the resistance is less than infinite, the armature is shorted.

Commutator to shaft Resistance

(∞)

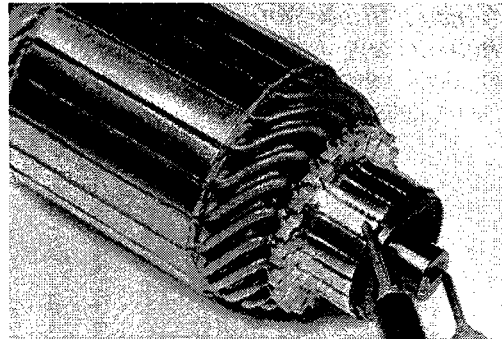

- Test the armature winding for shorts.
- Place the armature on a growler (A).
- Hold a thin metal strip (e.g., hack saw blade) on top of the armature.
- Turn on the growler and rotate the armature one complete turn.
- ★ If the metal strip vibrates, the windings are internally shorted to each other and the starter motor must be replaced.

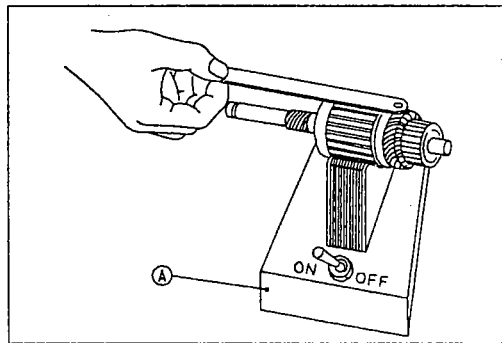

Yoke Assembly Inspection

- Set the hand tester selector switch to the R x 1k Ω position and measure the resistance between the positive brush(es) and the stator motor yoke.
- ★ If the resistance is less than infinite, the positive brush is shorted to ground. Replace the yoke assembly.

Positive Brush to Ground Resistance

(∞)

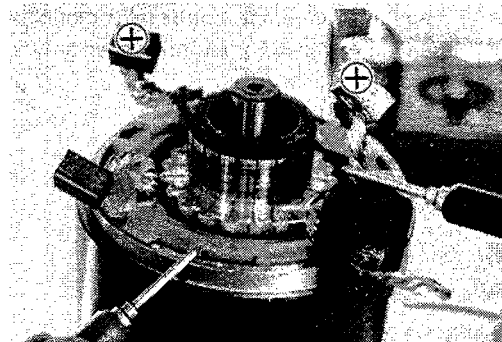

- Set the hand tester selector switch to the R x 1 Ω position and measure the resistance between the negative brush(es) and the starter motor yoke.
- ★ If the meter does not read close to 0 Ω , the yoke assembly is faulty. Replace it.

Negative Brush to Ground Resistance

Close to 0 Ω

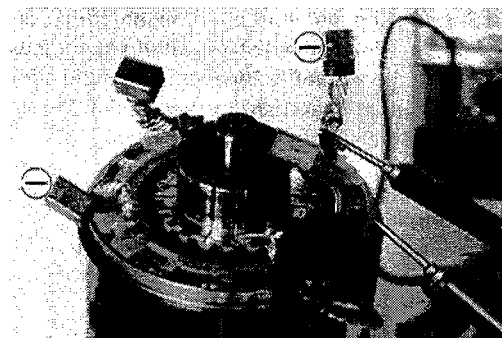

Pinion Clutch Inspection

- Remove the pinion clutch.
- Turn the pinion gear by hand. The pinion gear should turn counter-clockwise freely, but should not turn clockwise (→).
- ★ If the pinion clutch does not operate as it should, or if it makes noise, replace the pinion clutch.

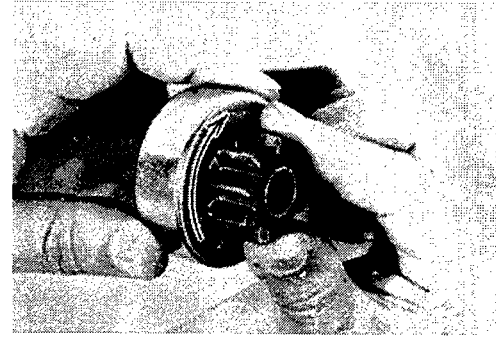

For Kawasaki Discount Parts Call 606-678-9623 or 606-561-4983

Troubleshooting

Table of Contents

Engine Troubleshooting Guide	8-2
Starter Motor Troubleshooting Guide	8-7

Engine Troubleshooting Guide

If the engine malfunctions, check if the way the engine is used is correct. If engine malfunctions even if engine is used correctly, systematically carry out troubleshooting starting with simple points.

This chart describes typical troubleshooting procedures.

Do not unnecessary disassemble carburetor, magneto or engine unless it has been found to be the cause of malfunctioning.

[Engine hard to start]

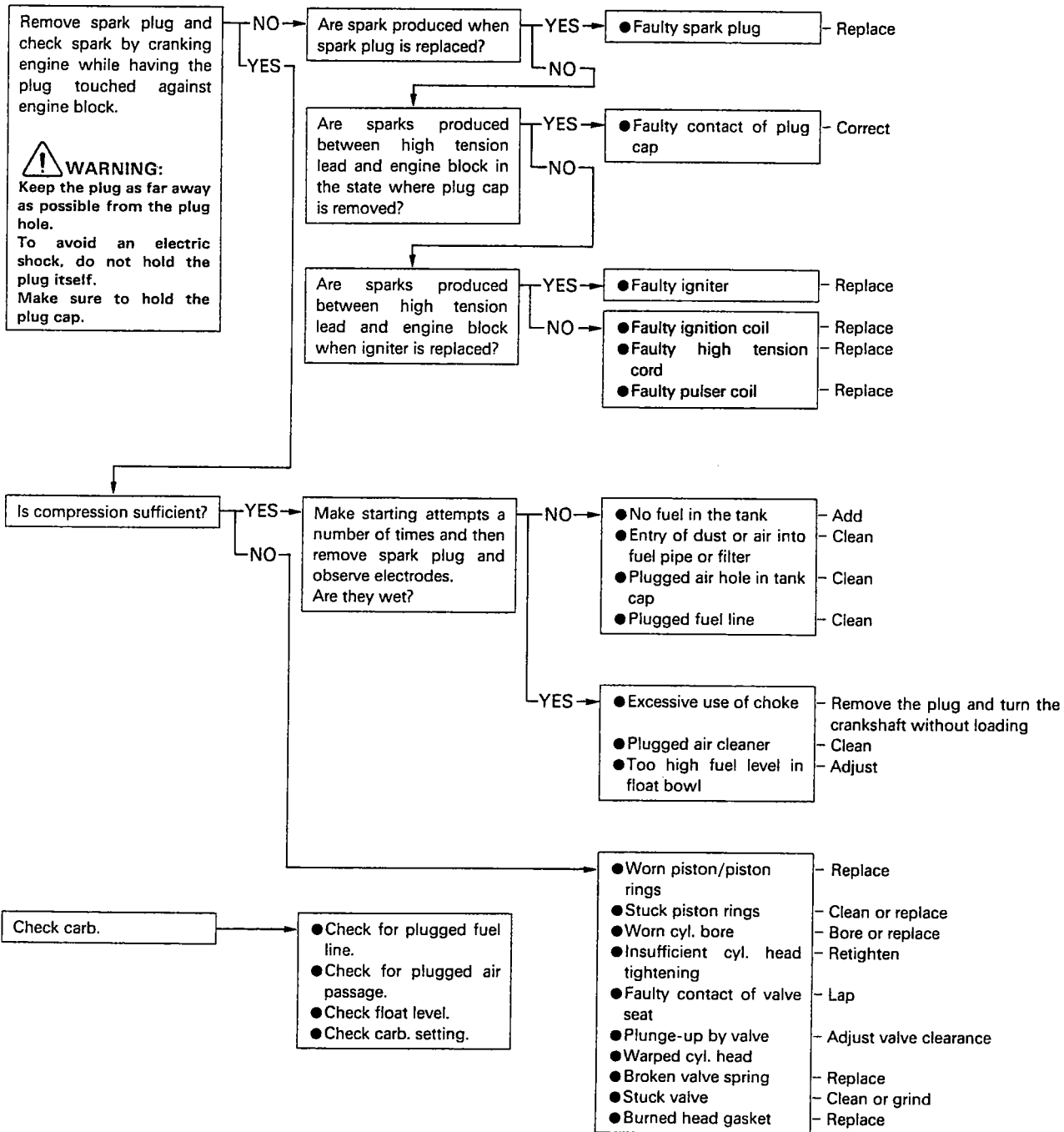

[Engine loss power]

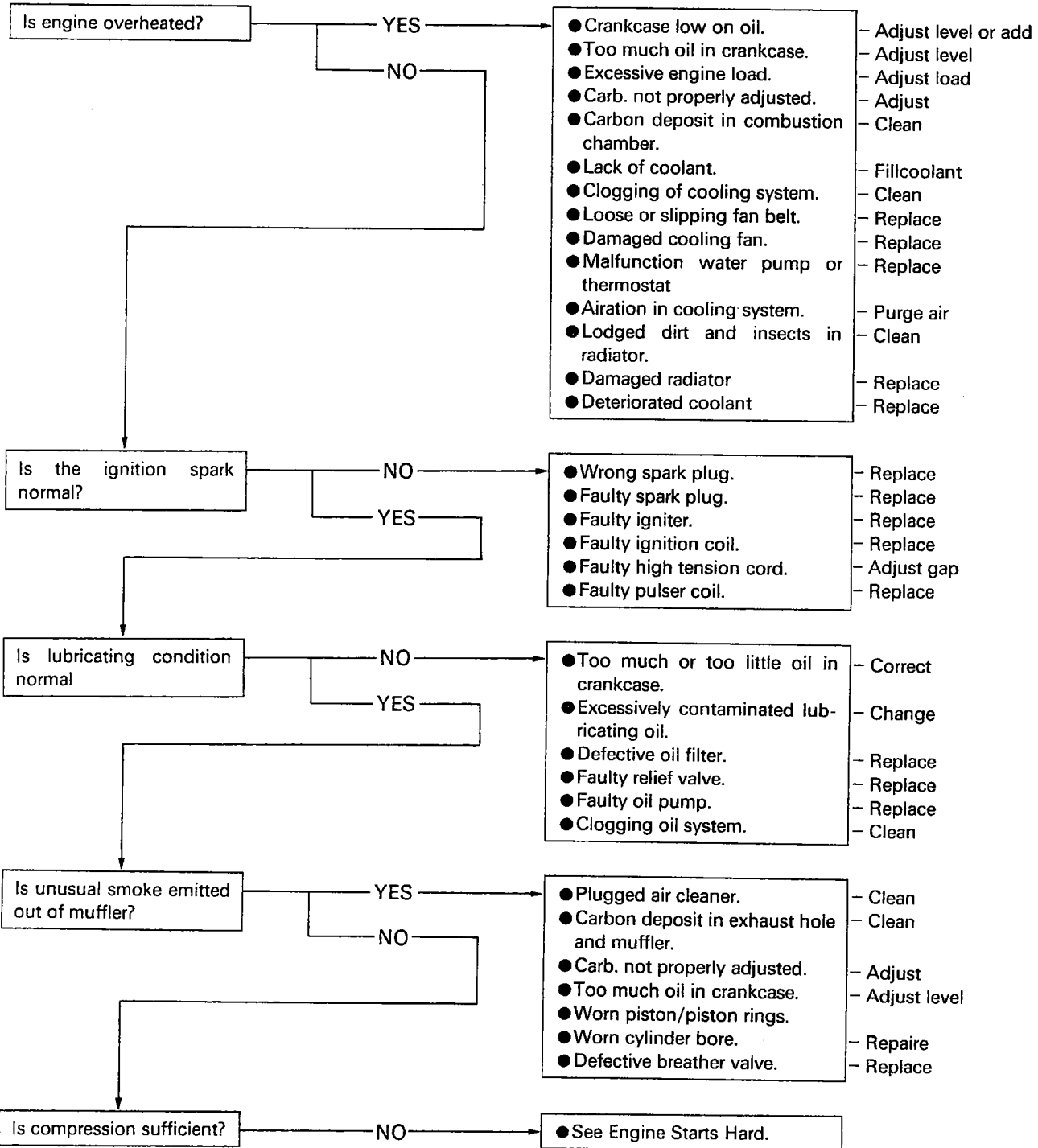

[Engine runs erratically]

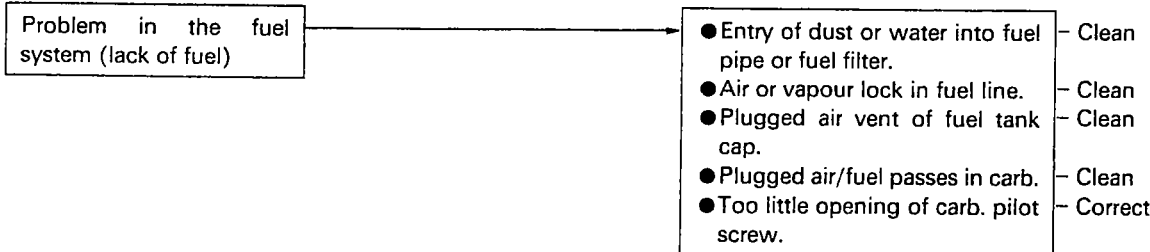

8-4 TROUBLESHOOTING

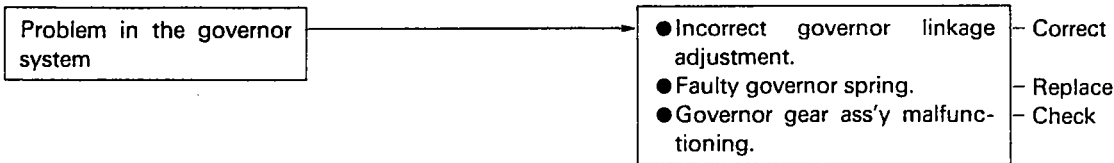

[Engine malfunctions at high speed]

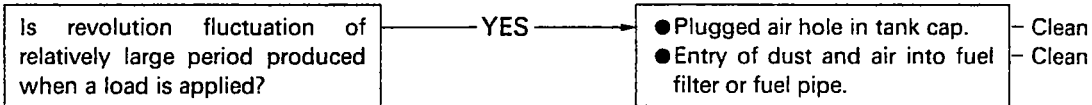

[Engine malfunctions at low speed]

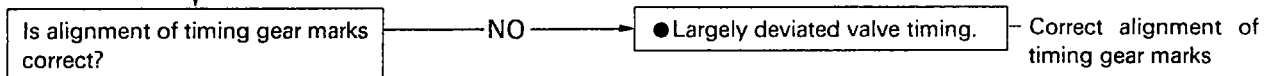
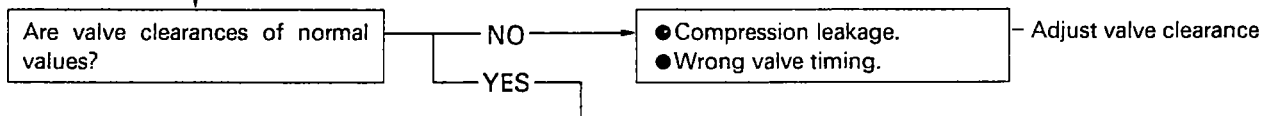
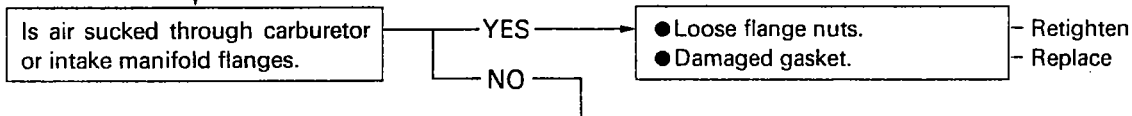
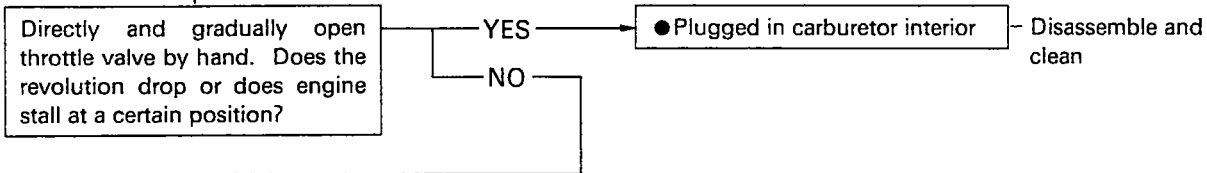
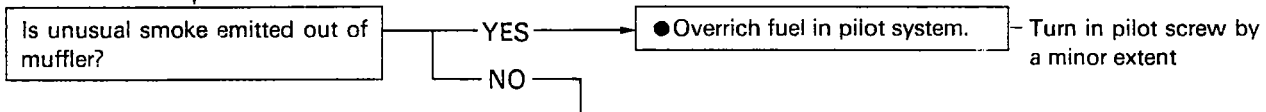
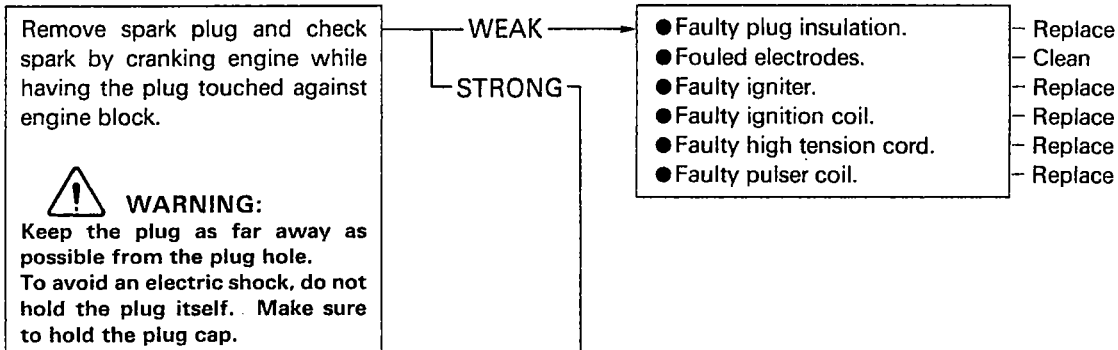

[Fuel consumption is excessive]

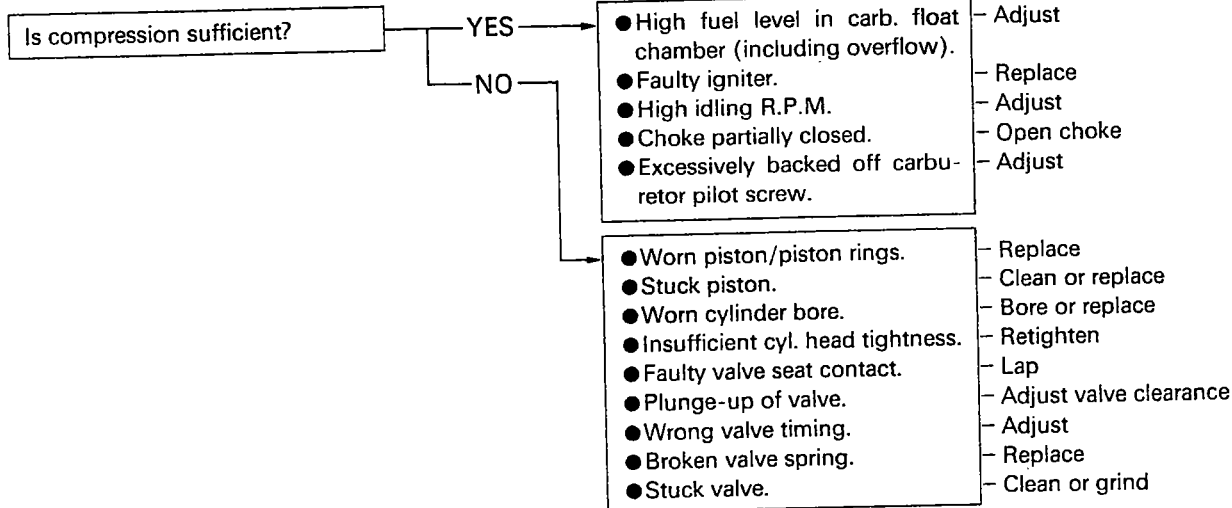

[Oil consumption is excessive]

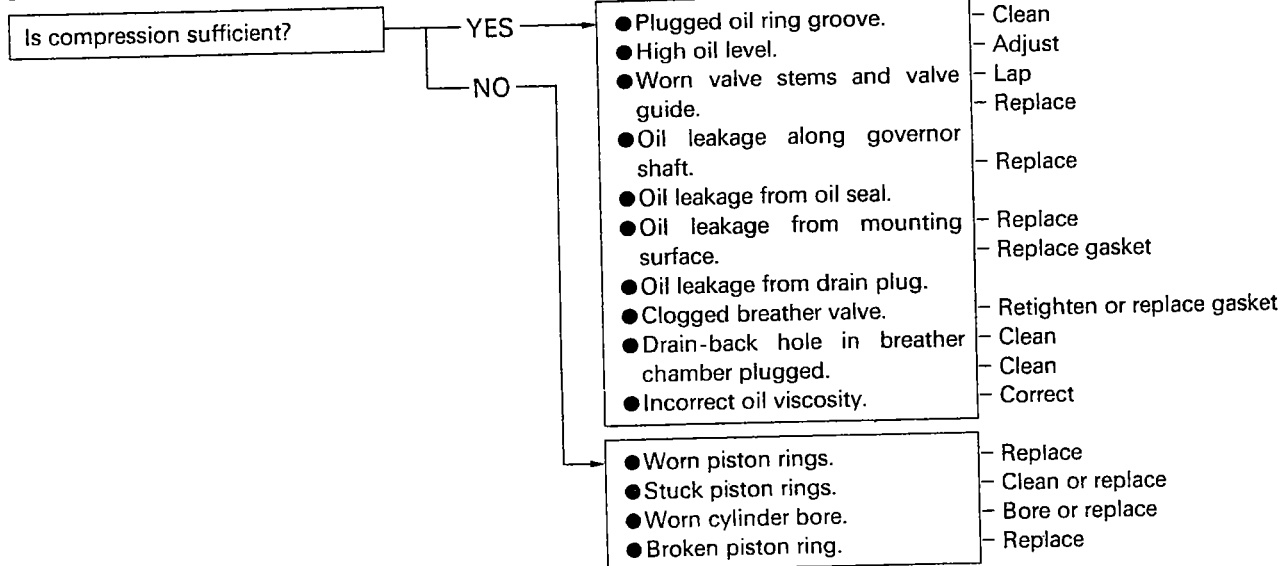

[Engine runs erratically]

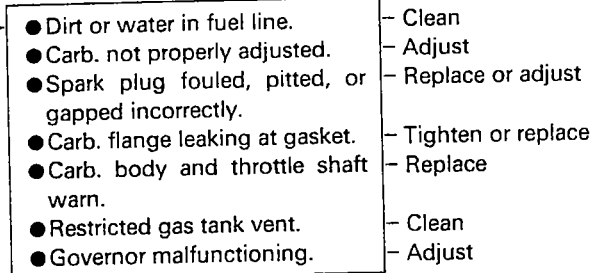

[Engine backfires]

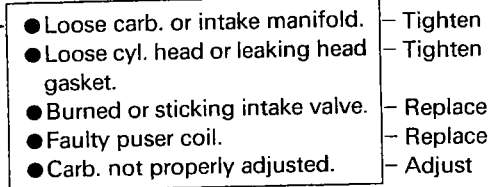

[Engine knocks]

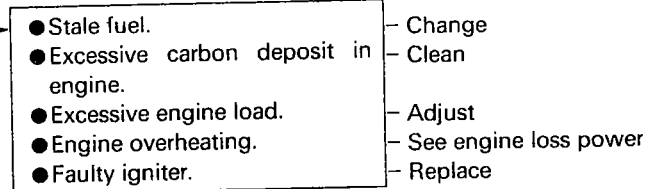

[Coolant leakage]

- | | |
|-----------------------------------|-------------------------|
| ● Deteriorated radiator hose. | - Replace |
| ● Mechanical failure of radiator. | - Repair or Replace |
| ● Loose cylinder head. | - Tighten |
| ● Cracked or porous casting. | - Replace |
| ● Loose stud bolts and cap screw. | - Repair |
| ● Engine overheating. | - See engine loss power |
| ● Damaged water pump sealings. | - Replace |
| ● Improperly installed gasket. | - Correct or Replace |
| ● Multifunction radiator cap. | - Replace |

Starter Motor Troubleshooting Guide

1. Disconnect spark plug cap, and ground the cap terminal.
2. Turn engine switch to "START" position and check condition.

⚠ WARNING
Engine may be cranked in this test. Do not touch any rotating parts of engine and equipment during test.

CAUTION
If starter does not stop by engine switch "OFF", disconnect negative (-) lead from battery as soon as possible.

[STARTER DOES NOT ROTATE]

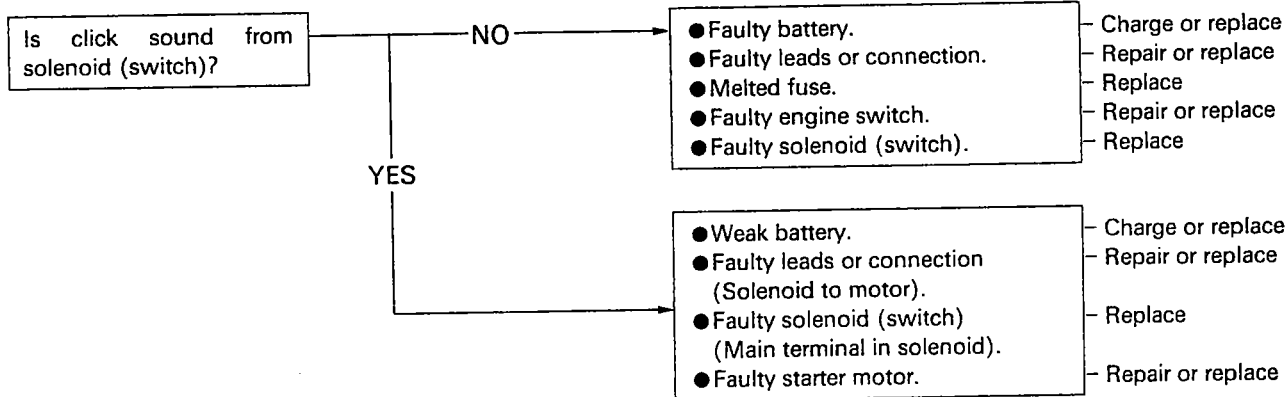

[STARTER ROTATES BUT SLOW]

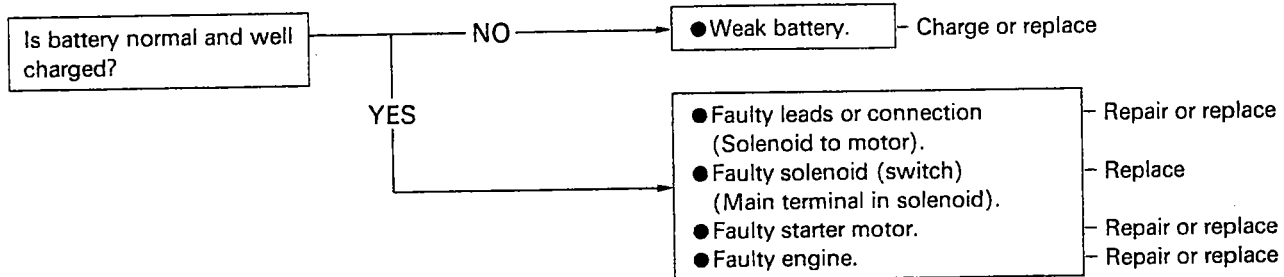

[STARTER ROTATES BUT CAN NOT CRANK ENGINE]

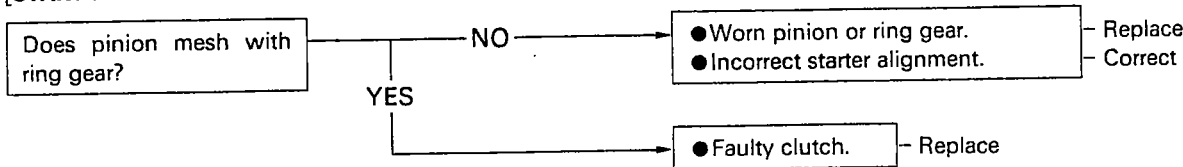

[STARTER DOES NOT STOP IN ENGINE SWITCH "OFF"]

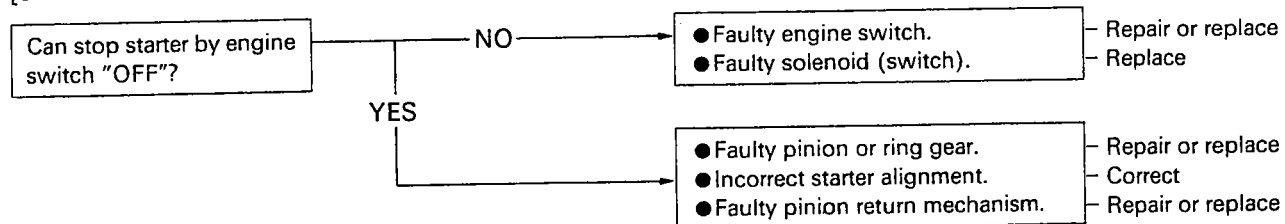

For Kawasaki Discount Parts Call 606-678-9623 or 606-561-4983

Supplement - FD661D Model

Table of Contents

Foreword	9-2
Model Identification	9-3
General Specifications	9-4
Periodic Maintenance Chart	9-5
Torque and Locking Agent	9-6
Fuel System	9-7
Exploded View	9-7
Specifications	9-9
Carburetor	9-10
Cooling System	9-12
Exploded View	9-12
Specifications	9-13
Engine Top End	9-13
Specifications	9-13
Lubrication System	9-14
Exploded View	9-14
Specifications	9-15
Camshaft / Crankshaft	9-16
Camshaft, Tappet	9-16
Electrical System	9-17
Specifications	9-17
Wiring Diagram	9-18
Charging System	9-20
Ignition System	9-21

Foreword

How to Use this Manual

This "Supplement - FD661D Model" designed to be used in conjunction with the front part of this manual (up to 8-7). The specifications and maintenance procedures described in this chapter are only those that are unique to the FD620D, FD661D models.

Complete and proper servicing the FD620D, FD661D models therefore requires mechanics to read both this chapter and the front of this manual.

General Information

Model Identification

FD620D Left Side View

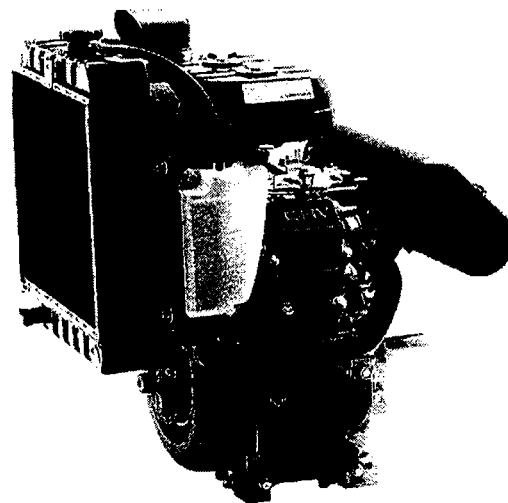

FD661D Left Side View

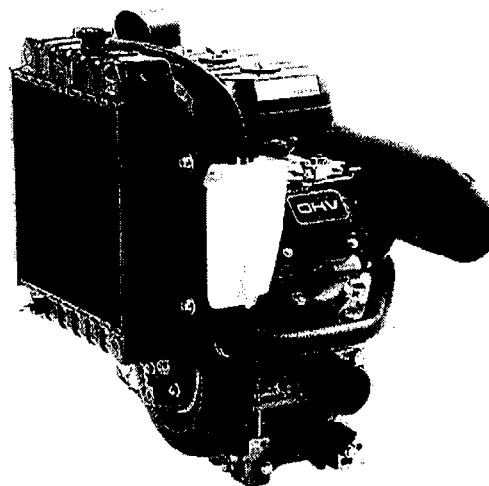

9-4 SUPPLEMENT - FD661D MODEL

General Specifications

Items	FD620D	FD661D
Type of engine	Liquid Cooled, Horizontal shaft, OHV, 4-stroke, 90° V-twin, Gasoline engine	←
Borexstroke	76 x 68 mm (2.99 x 2.66 in)	←
Piston displacement	617 mL (37.6 cu. in)	←
Direction of rotation	Counter-clockwise facing the PTO Shaft	←
Low idle speed	1475 ~ 1625 (rpm)	1550 ~ 1650 (rpm)
High idle speed	3575 ~ 3650 (rpm)	←
Carburetor	Float (Down draft) type, Fixed main jet	←
Fuel pump	Electro magnetic pump (in - line type)	←
Air cleaner	Dual element	←
Lubrication system	Pressure feed by positive displacement pump	←
Oil filter	Cartridge type full flow filter	←
Oil pressure switch	ON - OFF Switch	←
Oil capacity	1.5 L (3.2 U.S.A. Pint)	←
Cooling system	Pressurized forced circulation type	←
Radiator	3-rows with louverless corrugated fin	←
Ignition system	Battery, Fuel transistor, Fixed timing	←
RFI	Per Canada and U.S.A. requirements	←
Spark plug	NGK BMR4A	NGK BMR6A
Charging system	12V-20A with regulator	←
Starting system	Shift type electric starter	←
Governor	All speed mechanical fly weights	←
Dry weight	41.5 Kg (91.5 lbs) with muffler	←

Specifications are subject to change without notice.

Periodic Maintenance Chart

To ensure satisfactory operation over an extended period of time, any engine requires normal maintenance regular intervals. The Periodic Maintenance Chart below shows periodic inspection and maintenance items and suitable intervals. The bullet mark (●) designates that the corresponding item should be performed at that interval.

Some adjustments require the use of special tools of other equipment. An electronic tachometer will facilitate setting idle and running speeds.

▲ WARNING

Always remove the spark plug cap from spark plug when servicing the engine to prevent accidental starting.

MAINTENANCE	INTERVAL							
	Daily	First 8 hr.	Every 25 hr.	Every 50 hr.	Every 100 hr.	Every 200 hr.	Every 300 hr.	Every 400 hr.
Check and add engine oil	●							
Check for loose or lost nuts and screws	●							
Check for fuel and oil leakage	●							
Check battery electrolyte level	●							
Check or clean air intake screen	●							
Tighten nuts and screws			●					
★ Clean air cleaner foam element			●					
★ Clean air cleaner paper element					●			
Clean fuel filter element				●				
Change engine oil (without oil filter)		●		●				
Change engine oil (with oil filter)		●			●			
Clean and regap spark plug					●			
Change oil filter						●		
★ Replace air cleaner paper element							●	
★ Clean dust and dirt from cylinder and cylinder head fins							●	
K Clean combustion chamber							●	
K Check and adjust valve clearance							●	
K Clean and lap valve seating surface							●	
K Inspect radiator and hoses						●		
K Check fan belt conditions and tension						●		
K Change coolant								●

Note: The service intervals indicated are to be used as a guide. Service should be performed more frequently as necessary by operating condition.

★: Service more frequently under dusty conditions.

K: Have an authorized Kawasaki engine dealer perform those services.

Torque and Locking Agent

The following tables list the tightening torque for the major fasteners, and the parts requiring use of a non-permanent locking agent or liquid gasket.

Letters used in the "Remarks" column mean*

L : Apply a non-permanent locking agent to the threads.

M : Apply a molybdenum disulfide lubricant (grease or oil) to the threads, seated surface, or washer.

O : Apply an oil to the threads, seated surface, or washer.

S : Tighten the fasteners following the specified sequence.

Fastener	Torque			Remarks
	N-m	Kg-m	ft-lb	
Fuel System:				
Carburetor Mounting Nuts	17.0	1.7	12.0	
Governor Arm Nut	7.8	0.8	69 in-lb	
Fuel Shut-Off Solenoid Valve	9.8	1.0	7.0	
Intake Manifold Bolt	7.8	0.8	69 in-lb	
Cooling System:				
Radiator Mounting Bolts	17.0	1.7	12.0	
Cooling Fan Shaft Nut	20.0	2.0	14.5	
Water Pump Cover Bolts (M6)	9.8	1.0	87 in-lb	
Water Pump Cover Bolts(M8)	25.5	2.6	8.8	
Thermo Switch	27.0	2.8	20.0	L
Engine Top End:				
Cylinder Head Bolts and Nuts	21.0	2.1	15.0	S
Valve Clearance Adjust Nuts	8.8	0.9	78 in-lb	
Spark Plugs	15.0	1.5	11.0	
Lubrication System:				
Oil Drain Plug	23.0	2.3	16.5	
Oil Pressure Switch	9.8	1.0	87 in-lb	L
Oil Receiver Bolt	11.0	1.1	95 in-lb	
Camshaft/Crankshaft:				
Case Cover to Block Bolts	25.0	2.6	19.0	S
Con-Rod Cap Bolts	21.0	2.1	15.0	O
Electrical System				
Flywheel Nut	110.0	11.0	80.0	
Starter Motor "B" Terminal	9.8	1.0	7.0	

The right table, relating tightening torque to thread diameter, lists the basic torque for the bolts and nuts. Use this table for only the bolts and nuts which do not require a specific torque value. All of the values are for use with dry solvent-cleaned threads.

Basic Torque for General Fasteners

Threads dia. (mm)	Torque		
	N-m	kg-m	ft-lb
4	1.2 ~ 2.2	0.12 ~ 0.22	10 ~ 19 in-lb
5	3.4 ~ 4.9	0.35 ~ 0.50	30 ~ 43 in-lb
6	5.9 ~ 7.8	0.60 ~ 0.80	52 ~ 69 in-lb
8	14 ~ 19	1.4 ~ 1.9	10 ~ 14

Fuel System

Exploded View

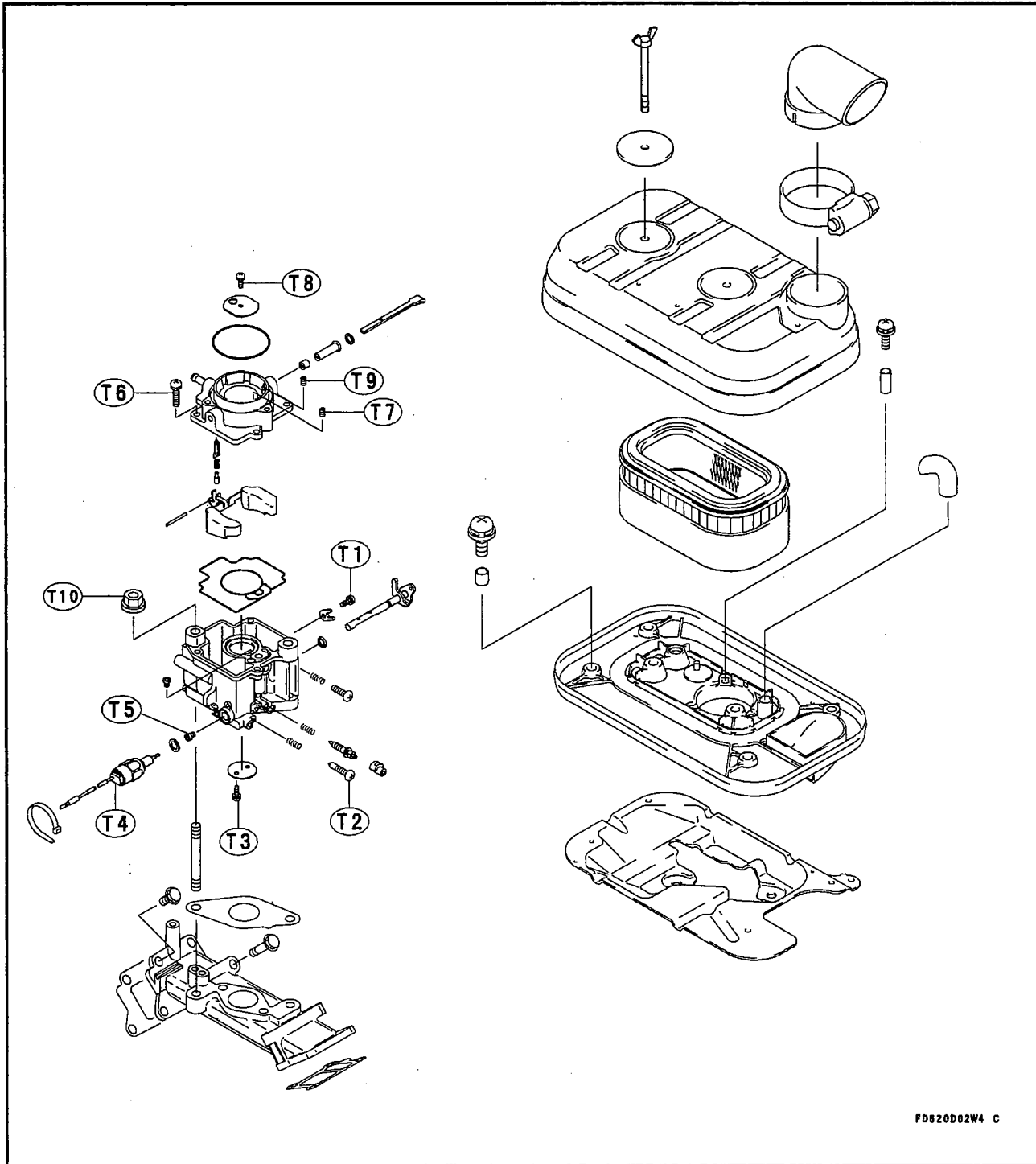

FD820D02W4 C

- T1: 2.00 N-m (0.20 kg-m, 17.0 in-lb)
(Stopper Screw)
- T2: 1.16 N-m (0.13 kg-m, 10.3 in-lb)
(Drain Screw)
- T3: 0.88 N-m (0.09 kg-m, 7.8 in-lb)
(Throttle Valve Screws)
- T4: 9.80 N-m (1.00 kg-m, 87.0 in-lb)
(Solenoid Valve)
- T5: 1.00 N-m (0.10 kg-m, 8.9 in-lb)
(Main Jet)

- T6: 2.94 N-m (0.30 kg-m, 26.0 in-lb)
(Air Hone Mounting Screws)
- T7: 1.00 N-m (0.10 kg-m, 8.9 in-lb)
(Pilot Air Jet)
- T8: 0.88 N-m (0.09 kg-m, 7.8 in-lb)
(Choke Valve Screw)
- T9: 1.00 N-m (0.10 kg-m, 8.9 in-lb)
(Main Air Jet)
- T10: 17.00 N-m (1.7 kg-m, 12.0 ft-lb)
(Carb. Mounting Nuts)

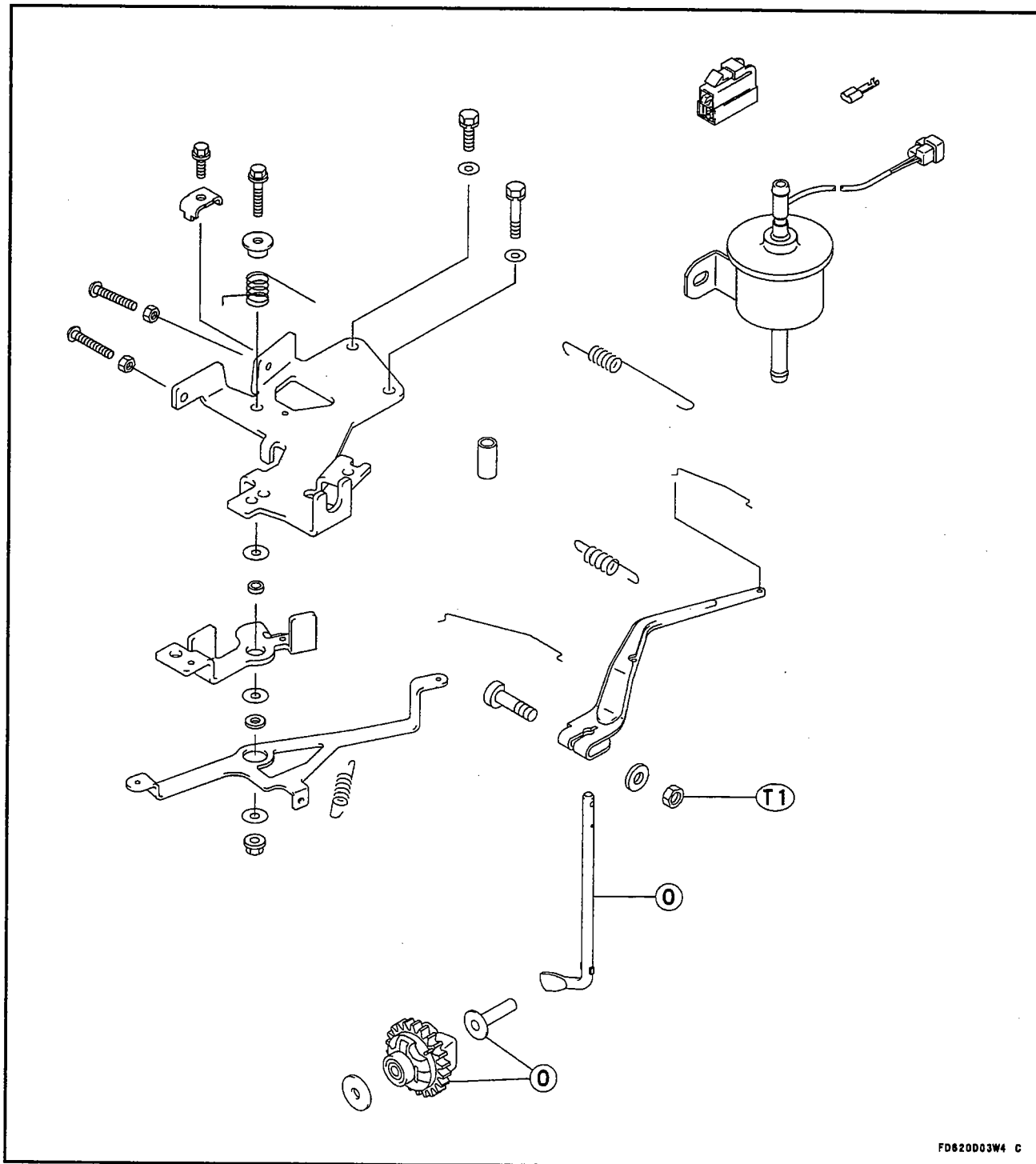

T1: 7.8 N-m (0.8 kg-m, 69 in-lb)

O: Apply engine oil

FD620D03W4 C

Specifications

Item	FD620D	FD661D
Carburetor Specifications: Make/type Main bore diameter Venturi diameter Main jet (MJ) Pilot jet (PJ) Main air jet (MAJ) Pilot air jet (PAJ) Pilot Screw turns out (PS) (Idle mixture screw turns out) Float level	TEIKEI/FD22K-1L 26 mm (1.02 in) 22 mm (0.87 in) #112 #58 ϕ 1.8 ϕ 0.9 1 1/4 \pm 1/4 19 to 21 mm (0.748 to 0.826 in)	TEIKEI/FD22K-1K ← ← #110 ← ϕ 1.4 ϕ 0.8 ← ←
Idle Speed: Low idle speed High idle speed	1475 (rpm) to 1625 (rpm) 3575 (rpm) to 3650 (rpm)	1550 (rpm) to 1650 (rpm) ←
Air Cleaner: Type Pre-cleaner Two-stage cleaner	Dual stage filtration system Foam element Paper element	
Fuel: Fuel requirement	Unleaded regular grade gasoline	
Fuel Pump: Type Rated voltage Delivery (MIN) Shut-off delivery pressure	Electro-magnetic Pump (in-line type) 12 VDC 400 mL (0.4 qt)/(MIN) at free flow 19.6 to 26.5 kPa (2.8 to 3.8 psi)	
Governor: Type	Flyweight all speed governor	

9-10 SUPPLEMENT - FD661D MODEL

Carburetor

Idle Mixture Screw (Pilot Screw)

▲ CAUTION

Do not attempt to adjust idle mixture screw with air cleaner removed

- Stop the engine.
- Turn the idle mixture screw (A) all the way in until it seats lightly.

▲ CAUTION

Do not turn the idle mixture screw in too far or the carburetor body will be damaged and require replacement

- Back the idle mixture screw out the specified number of turns (1 1/4).

Idle Mixture screw Turns Out

1 1/4 (Nearly About)

Low Idle Speed Adjustment

- Disconnect all possible external loads from the engine.
- Start the engine and warm it up thoroughly.

▲ WARNING

Always keep your hands clear of the moving parts.

- Move the throttle lever on dash to the idle position, and hold the throttle lever on the carburetor in closed position (turn the governor arm clockwise all the way) and adjust the low idle speed screw [A] until the engine idles at specified speed.

Low Idle Speed (Carburetor idle rpm)

FD661D- 1550 to 1650 (rpm)

FD620D- 1475 to 1625 (rpm)

- Release the throttle lever and adjust the low idle speed set screw [B] on the control plate to obtain the specified governed low idle speed.

Low Idle Speed (Governed idle rpm)

FD661D- 1650 to 1750 (rpm)

FD620D- 1575 to 1725 (rpm)

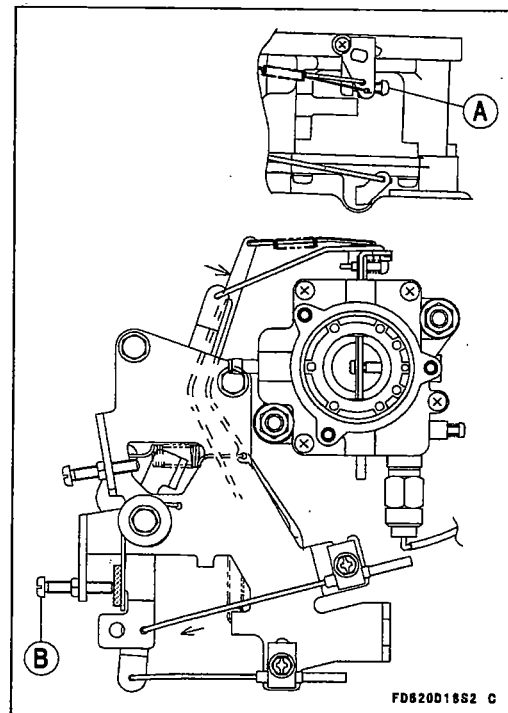

Fast Idle Speed Adjustment

NOTE

- Fast idle speed adjustment should be made after the idle speed adjustment is performed.

▲ CAUTION

Do not adjust fast idle speed with the air cleaner removed

- Start and warm up the engine thoroughly.

▲ WARNING

Always keep your hands clear of the moving parts.

- Turn the screw (C) counterclockwise 3 ~ 4 turns after loosening the lock nut.
- Move the throttle lever on dash to the high idle position, and adjust the throttle lever to obtain the specified high idle speed.

Fast Idle Speed

3575 to 3650 (rpm)

- Turn the screw (C) clockwise until touching the lever (D), and tighten the lock nut holding the screw (C) at this point.
- Check the idle speed, and readjust the idle speed if necessary.

▲ CAUTION

Be sure to make the idle and fast idle speeds respectively correspond to those of the equipment.

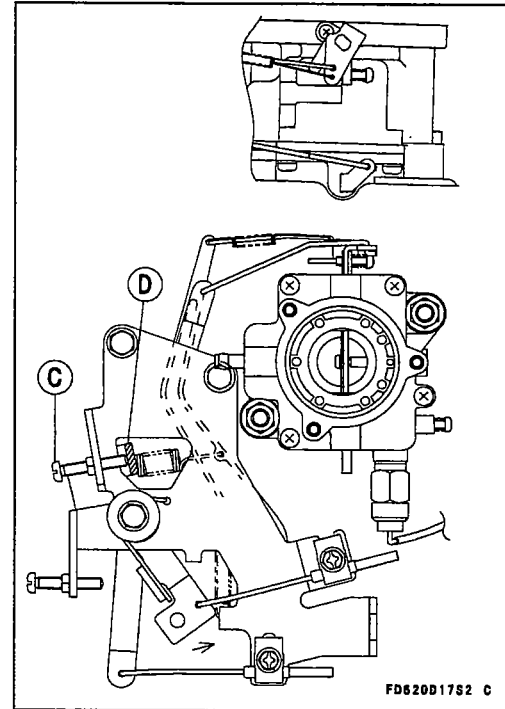

High Altitude Operation

At high altitude, the standard carburetor air-fuel mixture will be excessively rich. Performance will decrease, and fuel consumption will increase. High altitude performance can be improved by installing a smaller diameter main-jet in the carburetor and readjusting the pilot screw (idle mixture screw) to meet good idling and idle speed is the specified rpm.

NOTE

- The main jet high altitude kits are available if the equipment is to be used in the high altitudes. The main jet numbers are stamped on ends of the main jets.

High Altitude Main Jet	Main Jet No.	
	FD620D	FD661D
0 ~ 1000 m (0 ~ 3000 ft)	#112 (STD)	#110 (STD)
1000 ~ 2000 m (3000 ~ 6000 ft)	#110	#108
2000 m (6000 ft) and higher	#108	#106

9-12 SUPPLEMENT - FD661D MODEL

Cooling System

Exploded View

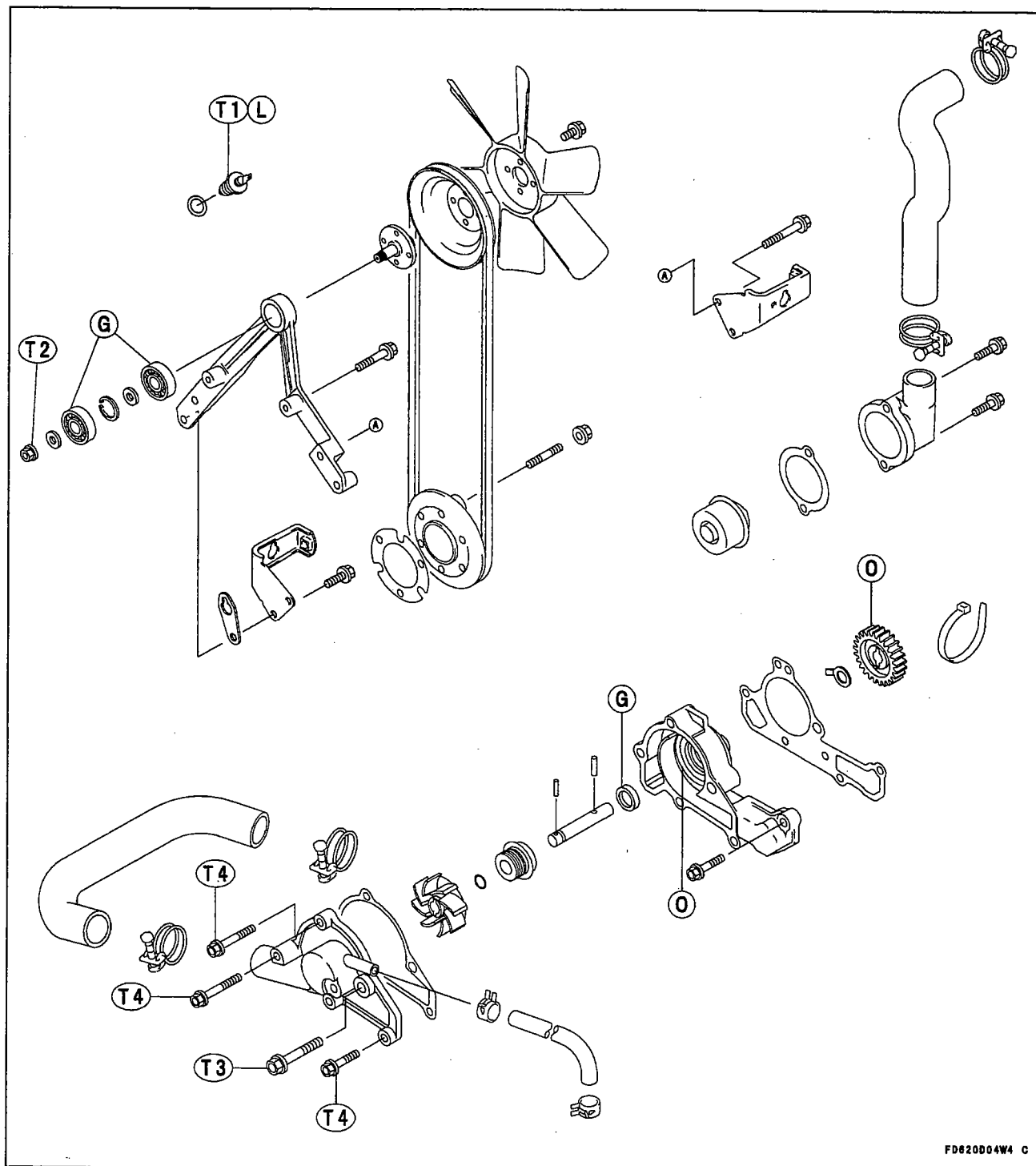

O: Apply engine oil

G: Apply grease

L: Apply a non-permanent locking agent to the threads

T1: 27 N-m (2.8 kg-m, 20 ft-lb)
(Thermo Switch)

T2: 20 N-m (2.0 kg-m, 14 ft-lb)
(Fan Shaft Nut)

T3: 25 N-m (2.6 kg-m, 19 ft-lb)
(Pump Cover Bolt M8)

T4: 9.8 N-m (1.0 kg-m, 87 in-lb)
(Pump Cover Bolt M6)

Specifications

Item	Standard
*Coolant: Type Color Mixed ratio Freezing point Total amount	Permanent type of antifreeze for aluminum engine and radiator Green 50% solution of ethylene glycol -35°C (-31°F) 2.7 L (0.7 us gallon)
Radiator Cap Relief Pressure: Pressure valve (positive) Vacuum valve (negative)	78.2 to 97.8 kPa (11.4 to 14.2 psi) 4.90 kPa (0.71 psi)
Thermostat: Valve opening temperature Valve full opening lift	80.5 to 83.5°C (177 to 182°F) not less than 8mm (0.31 in) at 95°C (203°F)
Thermo Switch: Detect Temperature	108 to 114°C (226 to 237°F)

*A permanent type of antifreeze is not installed in the cooling system when shipped.

Engine Top End

Specifications

Item	Service Limit
Cylinder Head: Cylinder compression	1470 kPa (213 psi)

9-14 SUPPLEMENT - FD661D MODEL

Lubrication System

Exploded View

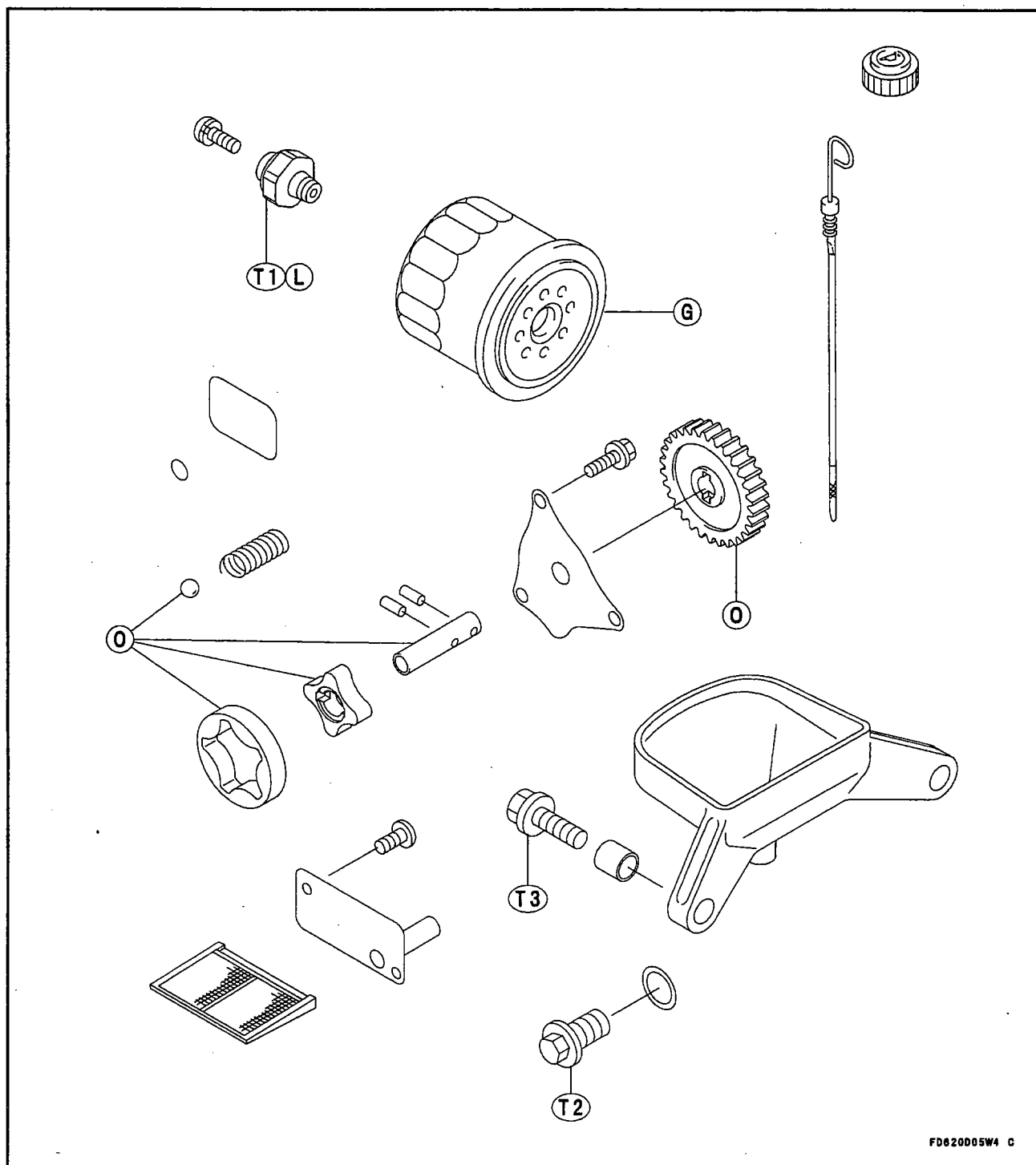

FD62005W4 C

T1: 9.8 N-m (1.0 kg-m, 87 in-lb)

T2: 23.0 N-m (2.3 kg-m, 16.5 ft-lb)

T3: 11 N-m (1.1 kg-m, 95 in-lb)

O: Apply engine oil

G: Apply grease

L: Apply a non-permanent locking agent to the threads.

Specifications

Item	Standard
Engine Oil:	
Grade	API Service Classification ; SC, SD, SE, SF, SG. or SH
Viscosity	SAE40, SAE30, SAE10W-30 / SAE10W-40, or SAE5W-20 (see Oil Change)
Capacity	1.8L (3.80 US pt) [When filter is not removed] 1.5L (3.17 US pt) [When filter is removed]
Level	Between upper and Lower level line
Oil Pressure (MIN)	276 kPa (40 psi)
Oil Pressure Switch:	
Detect pressure	69 ~127 kPa (10 ~18.5 psi)
Screw	PT 1/8 pipe thread
Oil Filter By-pass Valve Opening Pressure	78 to 118 kPa (11 to 17.1 psi)

Item	Service Limit
Oil Pump:	
Inner and outer rotor clearance	0.3 mm (0.012 in)
Outer rotor outside diameter	40.470 mm (1.5933 in)
Outer rotor thickness	9.830 mm (0.387 in)
Pump housing inside diameter	40.801 mm (1.606 in)
Pump housing depth	10.230 mm (0.4028 in)
Pump shaft outside diameter	10.923 mm (0.4300 in)
Relief valve spring free length	19.50 mm (0.77 in)
Pump shaft bearing inside diameter	11.072 mm (0.4359 in)

Camshaft / Crankshaft

Camshaft Tappet

Removal

- Split the crankcase (see Crankcase Splitting).
- Turn the crankcase up side down so that the tappets will fall away from the cam lobes.
- Pull the camshaft out of the crankcase.

NOTE

- Before removing, align the punch mark (A) on the crankgear with the punch mark (B) on the camgear.
- Remove the tappets and mark them so they can be installed in their original positions during assembly.

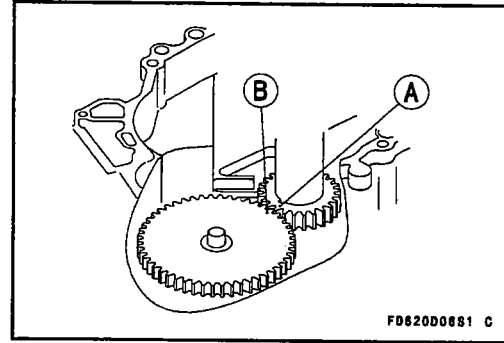

Installation Notes

- Apply engine oil to the following.
 - Tappet Journal
 - Camshaft Journal
 - Cam Lobe Surface
 - Camshaft Gear
- Align the punch mark on the crankgear with the projection on the camgear.

Inspection

- Check the camshaft gear (A) for pitting, fatigue cracks, burrs or an evidence of improper tooth contact. Replace the shaft if necessary.
- Check the top of the cam lobes (B) for wear, burrs or uneven contact. Replace the shaft if necessary.

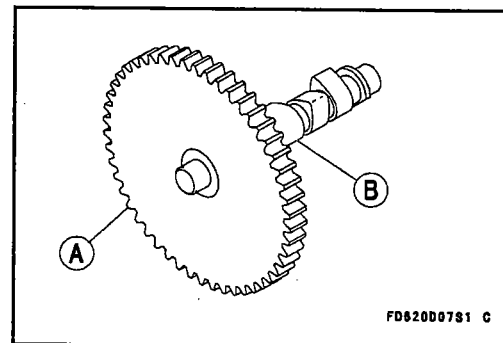

Camshaft Bearing/Journal Wear

- Measure the height of each cam lobe.
- ★ If the cam height is less than the service limit for either lobe, replace the camshaft

Cam Lobe Height

Service Limit: IN.25.21 mm (0.993 in.)
EX.25.46 mm (1.002 in.)

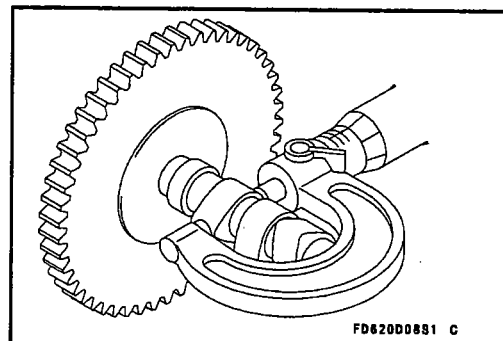

- With a micrometer, measure both camshaft journals at several points around the journal circumference.
- ★ If the journal diameter is less than the service limit, replace the camshaft.

PTO Side Journal Diameter

Service Limit: 15.907 mm (0.6263 in.)

Flywheel Side Journal Diameter

Service Limit: 15.917 mm (0.6267 in.)

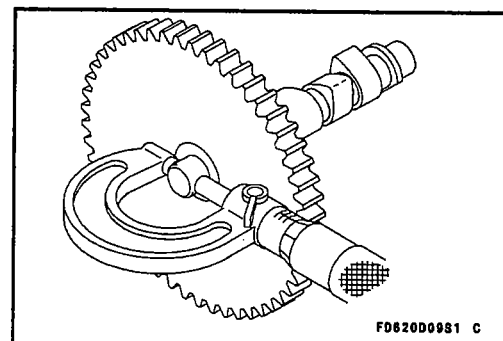

Electrical System

Specifications

Item	Standard	Service Limit
Charging System:		
Regulated output voltage	14~15V @3000 rpm	---
Alternator stator coil resistance	0.15~0.23Ω	---
Unregulated stator output	---	26VAC/3000 rpm
Regulator resistance	See charging system	
Ignition System:		
Pickup Coil:		
Coil air gap	0.45 to 0.95mm (0.012 to 0.037 in) (not adjustable)	---
Coil resistance	88 to 132Ω	---
Igniter resistance	See ignition system	---
Ignition coil:		
Primary winding resistance	3.4 to 4.6Ω	---
Secondary winding resistance	10.4 to 15.6 kΩ	---
Spark plug	(FD620D)NGK BMR4A, (FD661D)NGK BMR6A	---
Plug gap	0.6 to 0.7 mm (0.024 to 0.028 in.)	---
Electric Starter System:		
Starter motor:		
Carbon brush length	10 mm (0.394 in.)	6.0 mm (0.24 in.)
Commutator groove depth	0.5 to 0.8 mm (0.02 to 0.031 in.)	0.2 mm (0.008 in.)
Commutator diameter	28 mm (1.102 in.)	27 mm (1.06 in.)
Commutator runout	---	0.4 mm (0.016 in.)

FD620D Wiring Diagram

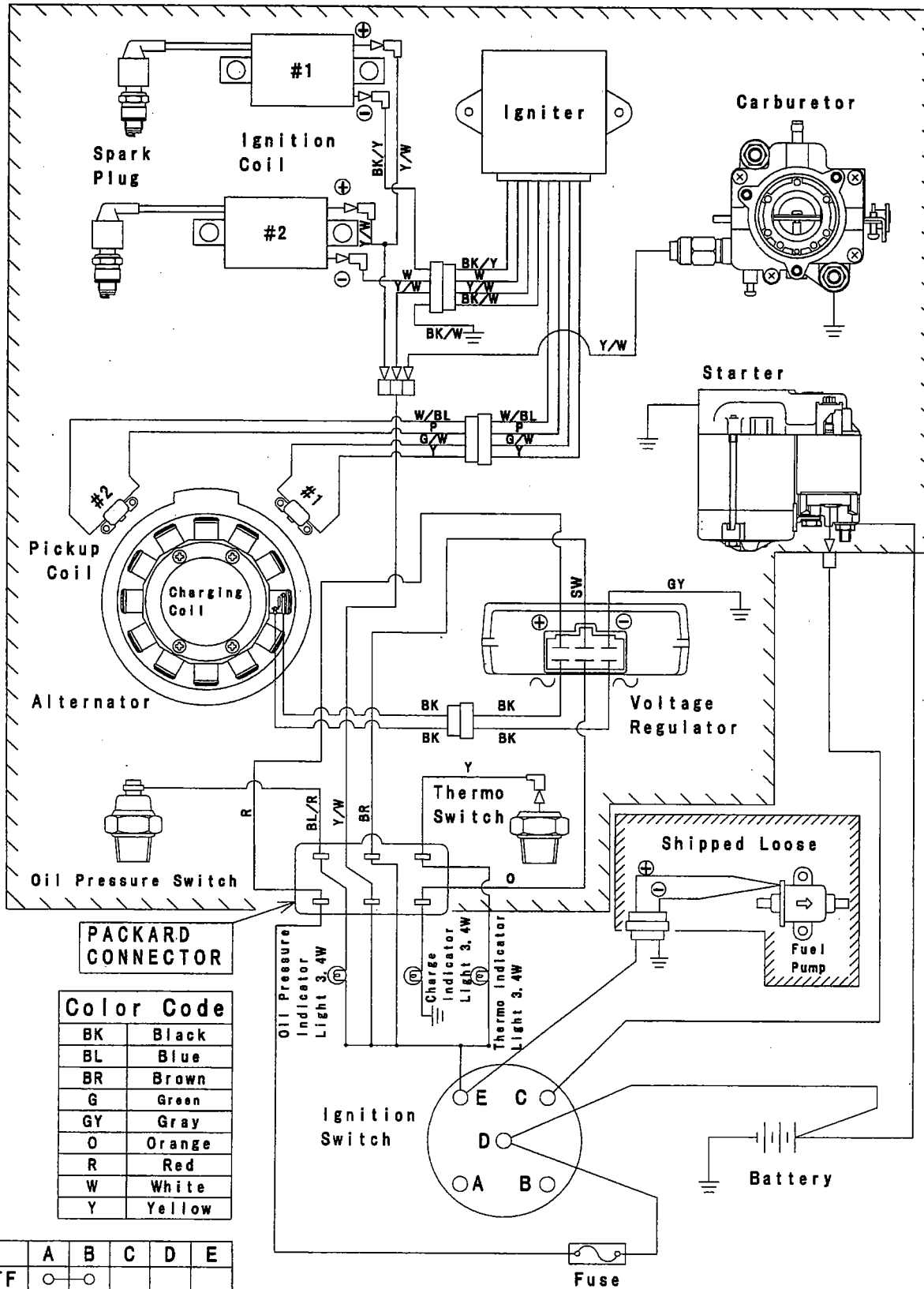

PACKARD CONNECTOR

Shipped Loose
Fuel Pump

Note: PORTION SURROUNDED BY // // // SHOWS KAWASAKI PROCURMENT PARTS

FD661D01W5 C

FD661D Wiring Diagram

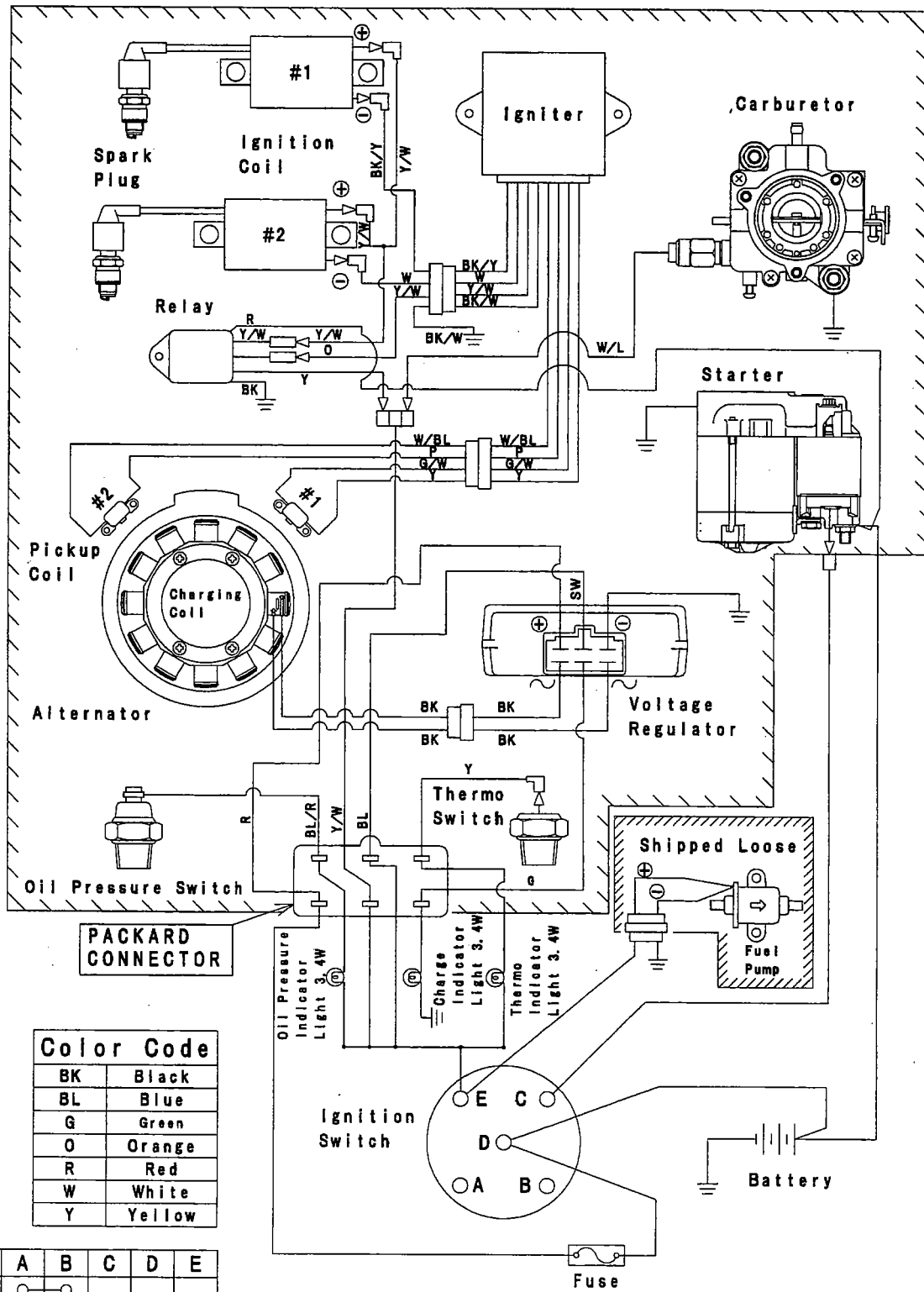

PACKARD CONNECTOR

Fuse

Note: PORTION SURROUNDED BY SHOWS KAWASAKI PROCURMENT PARTS

(49128-2537A)

FD661D02W5 C

Charging System

Charging System Operational Inspection

Regulated Output Voltage : 14 ~ 15V/3000 rpm

Charging Coil Resistance

- Disconnect the 2p connector of charging coil.
- Measure the charging coil resistance using Kawasaki Hand Tester.

Charging coil resistance : 0.15 ~ 0.23 Ω

- ★ If the meter does not read as specified, replace the charging coil.
 1. Charging coil, 2. 2p connector, 3. Hand tester
- Check for continuity between each charging coil pin and ground. There should be no continuity (infinite ohm.).
- ★ If the charging coil fails any of these tests, replace the coil with a new one.
 1. Charging coil, 2. 2p connector, 3. Hand tester

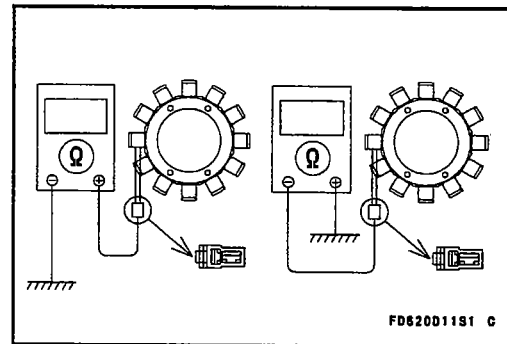
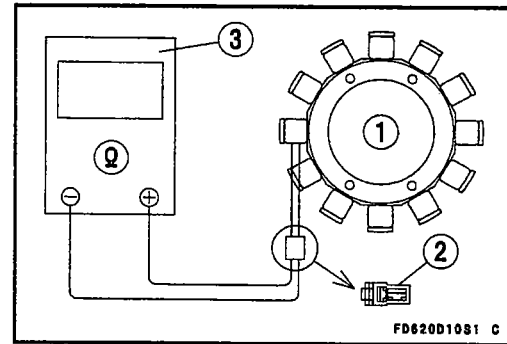

Unregulated Stator Output

- Disconnect the 2p connector of charging coil.
- Connect the Kawasaki Hand Tester to the 2p connector of charging coil.
- Start the engine. Run the engine at the 3000 rpm of speed.

Unregulated Stator Output : 26V AC/3000 rpm

- ★ If the AC voltage reading is less than the specification, replace the stator.
 1. Charging coil, 2. 2p connector, 3. Hand tester

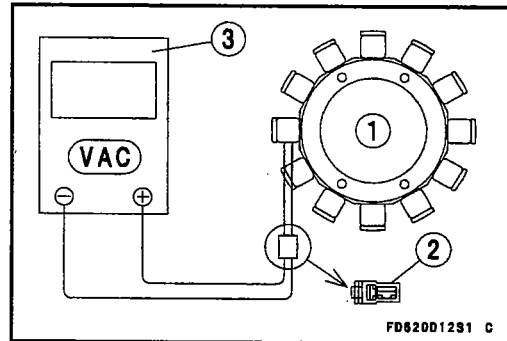

Ignition System

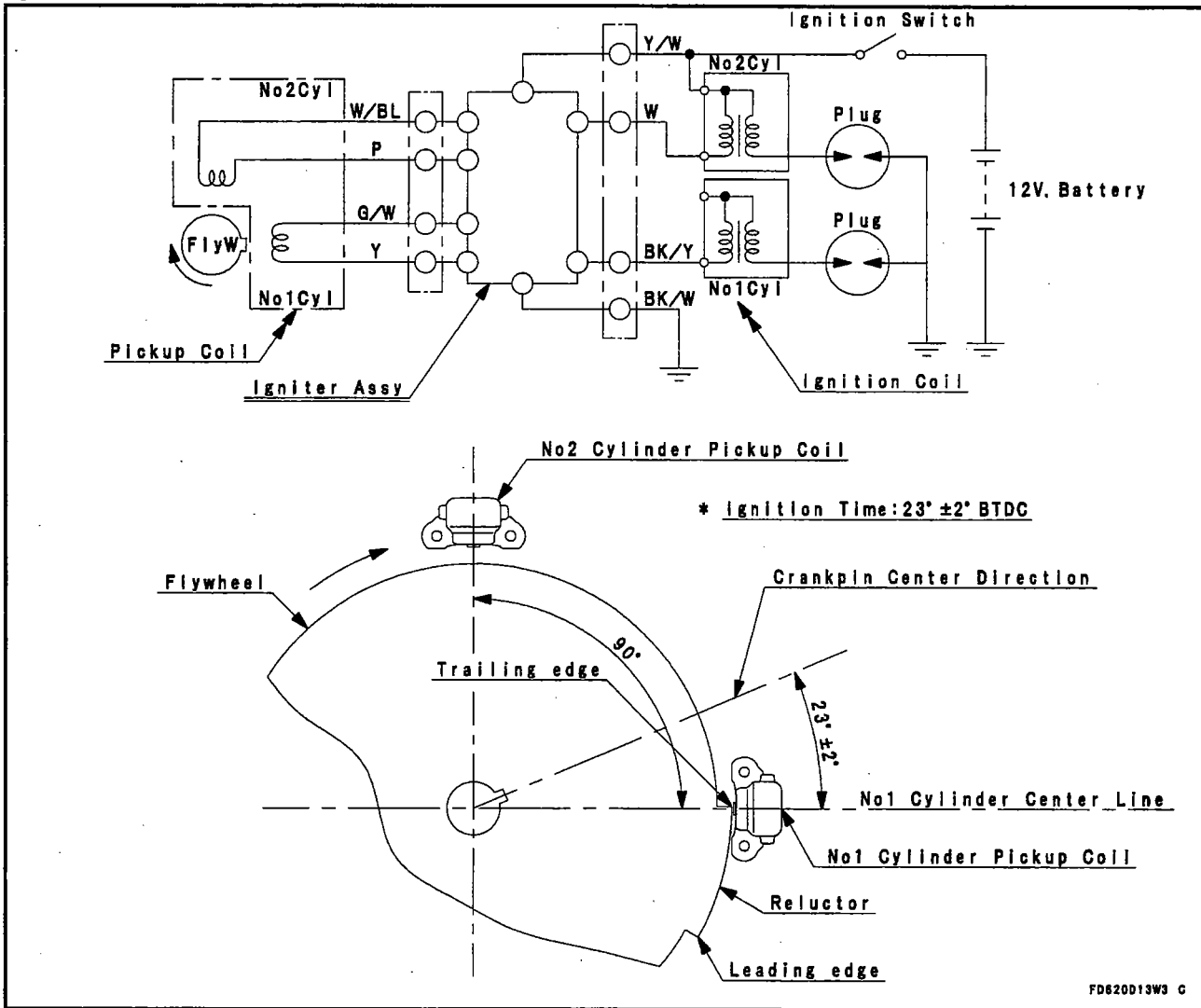

Transistor controlled battery ignition system is used in this engine. This ignition system is essentially a battery-ignition coil system where the battery supplies the current to the primary circuit in the system. This ignition system is transistorized and controls the current for the primary circuit by use of a electronic switching unit integrated into the igniter. The switching unit is triggered by pickup coils on each cylinder and contains no mechanical parts. This system consists of the following components.

- Ignition coil units
- Igniter (ignition Control Unit)
- Flywheel reluctor
- Pickup coils
- 12 V Battery
- Spark plugs

As the starter turns the flywheel, the reluctor in the flywheel runs past the pickup coils, this creates a magnetic field in the pickup coils and close the switching unit in the igniter and allow the current flow through the primary circuit in the ignition coils.

As the flywheel turns, the trailing reluctor passes under pickup coils, opening switching unit in the igniter and causing the primary coil current to stop suddenly. This creates an induced high voltage in a secondary coil windings, which fire the spark plugs.

Each spark plug fires every time the piston rises. When a spark does jump across the electrodes during the exhaust stroke, it will not affect on engine operation, since there is no compression and no combustible fuel/air mixture. The transistor controlled ignition system contains no mechanical parts, no wear occurs and no periodic maintenance is required except for the spark plug.

Pickup Coil Removal

- Remove:
 - Radiator and its Brackets
 - Flywheel Cover
 - Cooling Fan and its Brackets
- Disconnect the wire ties.
- Unscrew the pickup coil mounting screws and pull the pickup coils out of the cylinder block and leave them there.
- Disconnect the 4P coupler of the pickup coil leads end.
- Take off the pickup coils and its wire leads together.
 - A. Pickup Coils
 - B. Wire Tie
 - C. Mounting Screws

Installation Notes

- Installation is the reverse of removal.
- The pickup coils are mounted in a fixed position on each cylinder. No adjustment of the coil air gaps are required.
- When installing the coils on each cylinder, do not take the coil for another noting the wire color (see Wiring Diagram in this chapter).

Pickup Coil Air Gap (STD)

0.45 to 0.95 mm (0.012 to 0.037 in)

Pickup Coil Resistance

- Set the KAWASAKI hand tester selector switch to the R x 1 Ω position.
- Connect the test leads to the points shown on the chart and read the resistance.
- ★If the resistance is not as specified, replace the pickup coil.

Resistance Between	
[A] and [B]	[C] and [D]
88 Ω to 132 Ω	88 Ω to 132 Ω
←----- R x 1 Ω -----→	

NOTE

○Resistance value may vary with individual meters.

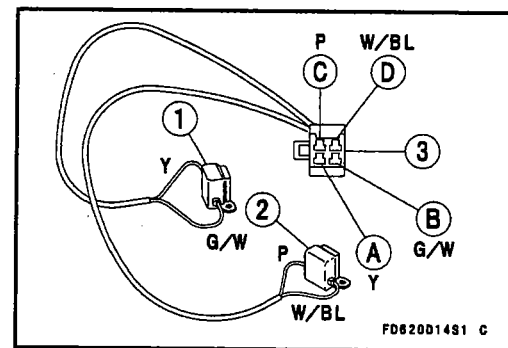

Igniter Inspection

- Remove the igniter.
- Unfasten the igniter lead connectors.
- Unscrew the mounting screws and remove the igniter.

- A. Igniter
- B. Lead Connectors (4P Couplers)
- C. Mounting Screws

- To inspect the igniter resistance, perform the following.
- Set the KAWASAKI hand tester selector switch to the R x 1 k Ω position.
- Connect the test leads to the points shown on the chart and drawing and read the resistance.
- ★ If the meter readings are not as specified, replace the igniter.

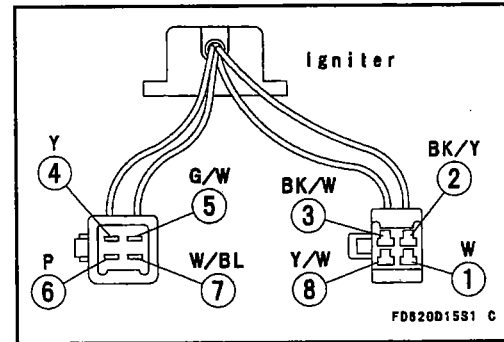

▲ CAUTION

Use only Kawasaki hand tester (special tool:57001-1394) for this test. A tester other than the Kawasaki hand tester may show different readings.

If a megger or a meter with a large-capacity battery is used, the igniter will be damaged.

Meter Range : k Ω
 Ambient Temperature (20°C)

k Ω		Tester (+) Terminal (Red)							
		Terminal	1	2	3	4	5	6	7
(-)*	1	-	∞	1 ~ 8	4 ~ 16	2 ~ 8	4 ~ 16	2 ~ 8	2 ~ 10
	2	∞	-	1 ~ 8	4 ~ 16	2 ~ 8	4 ~ 16	2 ~ 8	2 ~ 10
	3	∞	∞	-	1 ~ 6	0	1 ~ 6	0	0.5 ~ 2
	4	∞	∞	1 ~ 6	-	0	3 ~ 12	1 ~ 6	2 ~ 8
	5	∞	∞	0	1 ~ 6	-	1 ~ 6	0	0.5 ~ 2
	6	∞	∞	1 ~ 6	3 ~ 15	0.5 ~ 2	-	1 ~ 6	1 ~ 6
	7	∞	∞	0	1 ~ 6	2 ~ 8	1 ~ 6	-	0.5 ~ 2
	8	∞	∞	0.5 ~ 2	2 ~ 8	0.5 ~ 2	2 ~ 8	0.5 ~ 2	-

(-)*: Tester (-) Terminal (Black)

Relay Operation Inspection

The relay is equipped in the ignition system so that the engine continue to run from 0.7 second to 1.5 second without stopping after the ignition key switch off in order to avoid an after-burn or run-on of the engine

- Measure the resistance between each terminals of the relay using Kawasaki hand tester.
- Connect the tester as shown.
- ★ If the tester does not read as specified, replace the relay.

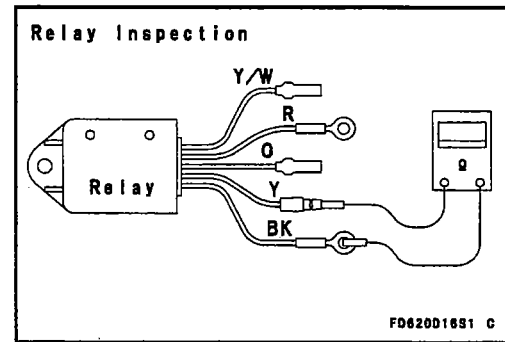

Relay Resistance

RX1 kΩ

- \ +	BK	R	Y	Y/W	O
BK		6.0 ~ 10 kΩ	∞	6.0 ~ 10 kΩ	∞
R	∞		∞	0 ~ 10 Ω	∞
Y	9.0 ~ 20 kΩ	10 ~ 100 kΩ		10 ~ 100 kΩ	∞
Y/W	∞	0 ~ 10 Ω	∞		∞
O	∞	150 ~ 500 Ω	∞	150 ~ 500 Ω	

For Kawasaki Discount Parts Call 606-678-9623 or 606-561-4983

For Kawasaki Discount Parts Call 606-678-9623 or 606-561-4983



Part No. 99924-2030-03

Printed in Japan

www.mymowerparts.com