

109638  
352-2400R

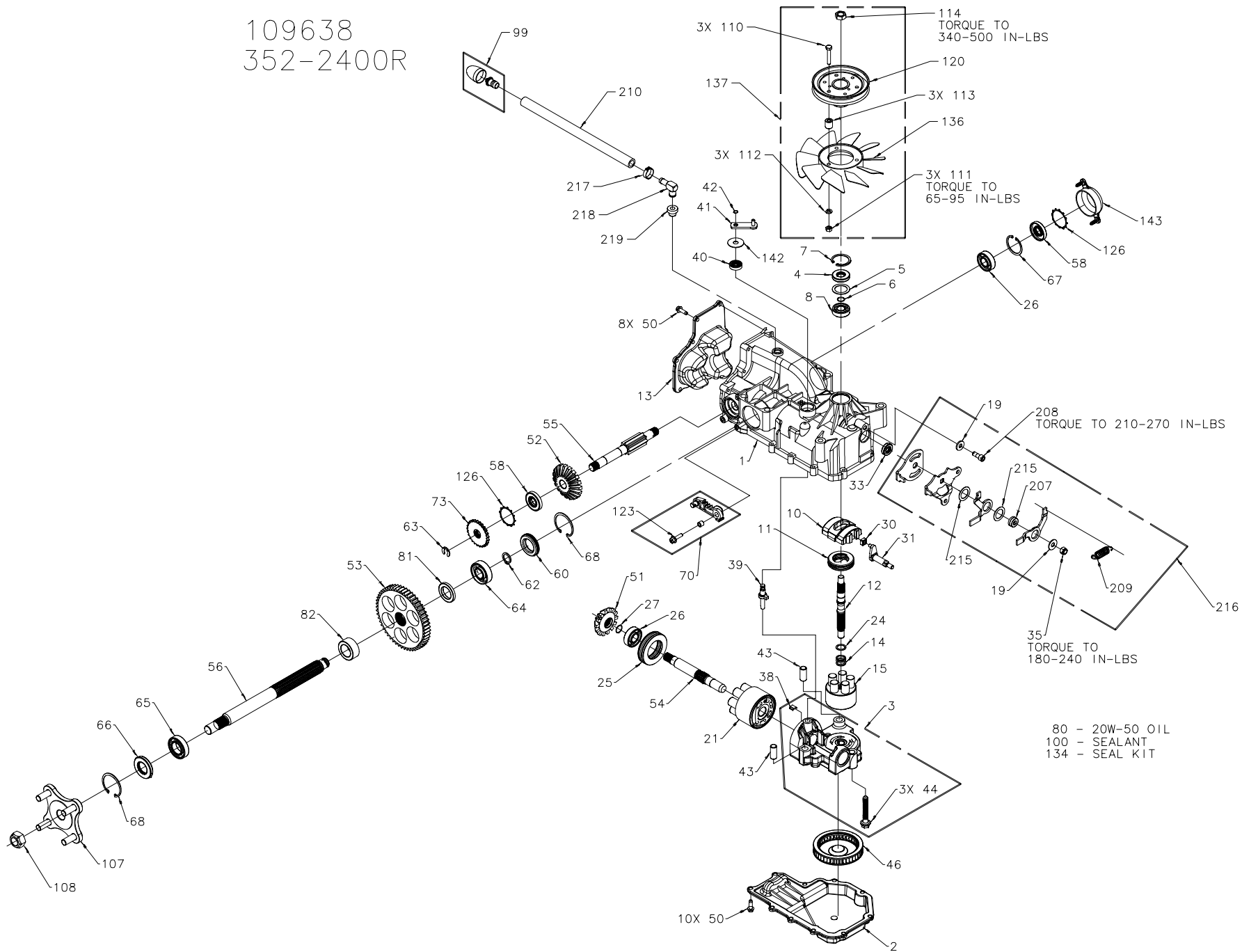

80 - 20W-50 OIL  
100 - SEALANT  
134 - SEAL KIT



109638  
352-2400R

For Hydro-Gear Parts Call K&T 606-678-9623 or 606-561-4983

ITEM NO.	HYDRO-GEAR PART NO.	QTY.	DESCRIPTION
1	70627	1	KIT, HOUSING-MAIN
		1	HOUSING, MAIN
		2	CRADLE BEARING
		1	SEAL, LIP 12 X 25 X 7
		1	TRUNNION BUSHING
		1	SCREW, HFHC 1/4-28 X 7/8 (PATCH)
2	50890RM	1	LOWER HOUSING
3	70667	1	KIT, CENTER SECTION
		1	CENTER SECTION
		1	BUSHING .67 X 1.03 X .75
		1	PLATE, BYPASS
		3	SCREW 3/8-24 X 2.5
		2	CHECK PLUG ASSEMBLY, .027
		1	LIP SEAL
4	9008000-0128	1	SPACER
5	2003018	1	WIRE RETAINING RING
6	2003016	1	RETAINING RING
7	2003052	1	BALL BEARING
8	2003043	1	VARIABLE SWASHPLATE
10	2003087	1	THRUST BEARING 30 X 52 X 13
11	50551	1	INPUT SHAFT
12	50005	1	COVER-BACK
13	50891RM	1	SPRING, BLOCK
14	2003014	1	10cc CYLINDER BLOCK ASS'Y
15	70331	1	10cc CYLINDER BLOCK
		5	10cc PISTON SPRING
		5	PISTON SEAT WASHER
		5	10cc PISTON
19	44130	2	WASHER
21	70082	1	21cc CYLINDER BLOCK ASS'Y
		1	21cc CYLINDER BLOCK
		7	21cc PISTON SPRING
		7	PISTON SEAT WASHER
		7	10cc PISTON
24	2003017	1	WASHER, BLOCK THRUST
25	50552	1	THRUST BEARING 42 X 68 X 16
26	50315	2	BALL BEARING
27	2000022	1	WIRE RETAINING RING
30	2000015	1	SLOT GUIDE
31	50807	1	TRUNNION ARM
33	9008000-0126	1	LIP SEAL
35	50108	1	NUT
38	70680	1	KIT, BYPASS PLATE
39	2003555	1	BYPASS ACTUATOR
40	45074	1	LIP SEAL
41	50270	1	BYPASS ARM
42	44870	1	RETAINING RING
43	50002	2	PIN
44	50016	3	SCREW
46	50990	1	FILTER
50	50752	18	SCREW, 1/4-20 X .75 LONG
51	50744	1	14T BEVEL GEAR
52	50745	1	19T BEVEL GEAR

ITEM NO.	HYDRO-GEAR PART NO.	QTY.	DESCRIPTION
53	50746	1	53T SPUR GEAR
54	50757	1	MOTOR SHAFT
55	51298	1	BRAKE SHAFT
56	50748	1	AXLE SHAFT
58	51161	2	SEAL, LIP 17 X 40 X 7
60	50995	1	SEAL PLUG - SIDE
62	50759	1	RETAINING RING - AXLE
63	51109	1	RING, RETAINING
64	50743	1	BEARING-BALL 20X47X14(6204)
65	50740	1	BEARING-BALL 25X47X12(6005)
66	50751	1	SEAL
67	50329	1	RETAINING RING
68	50760	2	RETAINING RING-AXLE
70	71087	1	KIT, BRAKE ARM (LH)
		1	BRAKE ARM
		1	CLEVIS PIN
		1	BUSHING 0.255 X 0.381 X 0.330
		1	SCREW, HFHCS 1/4-28
73	50754	1	BRAKE DISC
80		79oz	20W-50 OIL
81	51939	1	WASHER, AXLE 1.04 X 1.65 X .22
82	51940	1	WASHER, AXLE 1.04 X 1.65 X .70
99	70921	1	CAP VENT ASSEMBLY
		1	CAP, PLASTIC
		1	VENT, PLASTIC
100	50928	1	SEALANT
107	70314	1	HUB ASSEMBLY
		1	HUB
		4	LUG BOLT
108	50863	1	NUT, HEX 3/4-16
110	44276	3	SCREW, 1/4-20 X 1-1/2
111	43178	3	NUT, 1/4-20
112	43177	3	LOCKWASHER
113	50259	3	SPACER
114	44133	1	NUT, 1/2-20
120	50302	1	PULLEY, Ø4.50 X 1.625
123	51576	1	SCREW, HFHC 1/4-28 X 7/8 (PATCH)
126	51316	2	RING, RETAINING
134	70553	1	KIT, SEAL
		1	SEAL, LIP 15 X 35 X 7
		1	RING, RETAINING
		1	SEAL, LIP 12 X 25 X 7
		1	SEAL, LIP 10 X 25 X 7
		1	RING, RETAINING
		2	SEAL, LIP 17 X 40 X 7
		1	SEAL, LIP 1.85 X .32
		1	RING, RETAINING
		1	RING, RETAINING .440 EXTERNAL
		1	SEAL, LIP .98 X 1.85 X .276
		1	RING, RETAINING
		2	RING, RETAINING
		2	RING, RETAINING

ITEM NO.	HYDRO-GEAR PART NO.	QTY.	DESCRIPTION
136	50307	1	FAN, 7 INCH, 10 BLADE
137	70243	1	KIT,FAN/PULLEY
		1	WASHER (LOCK) 1/4
		1	NUT, HEX 1/4-20
		1	NUT, HEX 1/2-20 PATCH
		1	HHCS 1/4-20X1.5 (PATCH)
		1	SPACER .26X.57X.62
		1	PULLEY 4.5 X 1.625
		1	FAN 7.0 (10 BLADE)
142	51813	2	WASHER, .39 X 1.27 X .05
143	51774	1	CAP, BRAKE
207	51604	1	SPACER, RTN
208	51400	1	SCREW, 5/16-24 X (PATCH)
209	51399	1	SPRING, EXTENSION
210	50632	1	HOSE, .5 X 12.0
215	51408	2	WASHER, NYLON
216	70609	1	KIT, RTN
		1	WASHER
		1	HEX LOCK NUT, 5/16-24 UNJF (NYLON INSERT)
		1	SPACER, RTN
		1	SCREW, 5/16-24 X .75 (PATCH)
		1	SPRING EXTENSION
		1	WASHER, NYLON
		1	CONTROL ARM
		1	ARM, RTN SCISSOR, OUTER
		1	ARM, RTN SCISSOR, INNER
		1	ARM RETURN
217	50590	1	PINCH CLAMP, SINGLE EAR
218	50308	1	FITTING, METAL VENT
219	50133	1	VENT, BUSHING

www.mymowerparts.com