

D48001  
325-0500

For Hydro-Gear Parts Call K&T 606-678-9623 or 606-561-4983

www.mymowerparts.com

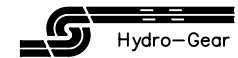
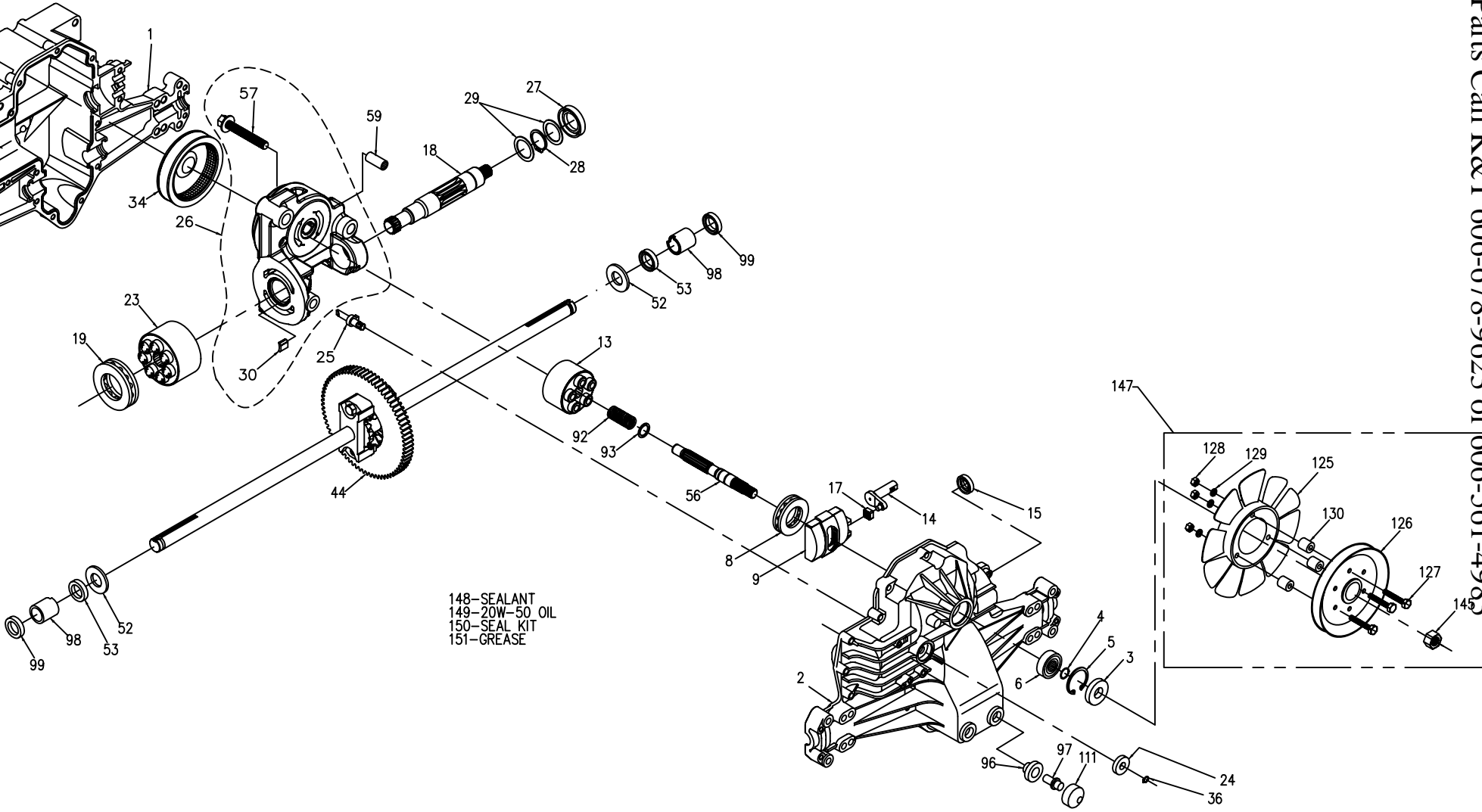

D48001  
325-0500

ITEM NO	HYDRO-GEAR PART NO	QTY	DESCRIPTION
1	44863RM	1	HOUSING, LOWER
2	70124	1	ASSEMBLY, UPPER HOUSING
		1	UPPER HOUSING
		1	TRUNNION JOURNAL BEARING
		2	CRADLE BEARING
3	9008000-0128	1	SEAL-LIP
4	2003016	1	RING-WIRE RETAINING
5	2003052	1	RING-RETAINING
6	2003043	1	BEARING-SHAFT BALL
8	50551	1	BEARING-THRUST 30X52X13
9	2003087	1	SWASHPLATE-VARIABLE
13	70331	1	BLOCK-CYLINDER ASS'Y.
		1	BLOCK-CYLINDER
		5	PISTON
		5	PISTON SPRING
		5	PISTON SPRING WASHER
14	2003005	1	ARM-TRUNNION
15	9008000-0126	1	SEAL-LIP
17	2000015	1	GUIDE-SLOT
18	50449	1	SHAFT-MOTOR
19	50552	1	BEARING-THRUST 42X68X16
23	70608	1	BLOCK-CYLINDER ASS'Y.
		1	BLOCK-CYLINDER
		7	PISTON
		7	PISTON SPRING
		7	PISTON SPRING WASHER
24	45074	1	SEAL-LIP 10X25X7
25	2003555	1	ACTUATOR-BYPASS
26	70494	1	KIT, CENTER SECTION
		1	PLATE, BYPASS
		2	CHECK PLUG ASSEMBLY
		1	CENTER SECTION
		2	BUSHINGS
		3	BOLT, 3/8-24 X 2.5
27	45075	1	SEAL-LIP 26X42X8
28	50007	1	RING-RETAINING
29	44872	2	WASHER-26X35X1
30	70680	1	KIT, BYPASS PLATE
34	50990	1	FILTER
36	44870	1	RING-RETAINING

ITEM NO	HYDRO-GEAR PART NO	QTY	DESCRIPTION
44	70126	1	DIFFERENTIAL ASSEMBLY
		2	AXLE SHAFT
		1	72T DIFFERENTIAL GEAR
		2	DIFFERENTIAL HOUSING
		2	14T BEVEL GEAR
		2	10T PLANET GEAR
		2	RETAINING RING
		2	DIFFERENTIAL LOCKING BOLT
		1	DIFFERENTIAL SPACER
52	44875	2	WASHER-3/4 X 1.5 X .13
53	45076	2	SEAL- .75 X 1.25 X .250
56	50005	1	SHAFT-INPUT
57	50016	3	BOLT, 3/8-24 X 2.5
58	44876	20	BOLT- 1/4-20 X 1.38
59	50002	2	PIN- .5 OD X .43 ID X .750
92	2003014	1	SPRING, BLOCK
93	2003017	1	WASHER, BLOCK THRUST
96	50133	1	BUSHING, VENT
97	50134	1	VENT
98	50137	2	SLEEVE BEARING
99	50941	2	SEAL, LIP .75 X 1.00 X .158
111	50196	1	VENT CAP
125	50307	1	FAN
126	51173	1	PULLEY
127	44276	3	SCREW, 1/4-20 X 1-1/2
128	43178	3	NUT, 1/4-20
129	43177	3	LOCK WASHER
130	50259	3	SPACER
145	44133	1	HEX NUT 1/2-20 (PATCH)
147	70418	1	FAN/PULLEY KIT
		1	FAN
		1	PULLEY
		3	SCREW, 1/4-20 X 1-1/2
		3	NUT, 1/4-20
		3	LOCK WASHER
		3	SPACER
		1	HEX NUT 1/2-20 (PATCH)
148	50928	1	SEALANT
149		77oz	20W-50 OIL
150	70312	1	SEAL KIT
151	50416	1	GREASE

For Hydro-Gear Parts Call K&T 606-678-9623 or 606-561-4983

www.mymowerparts.com

