

314-2600L

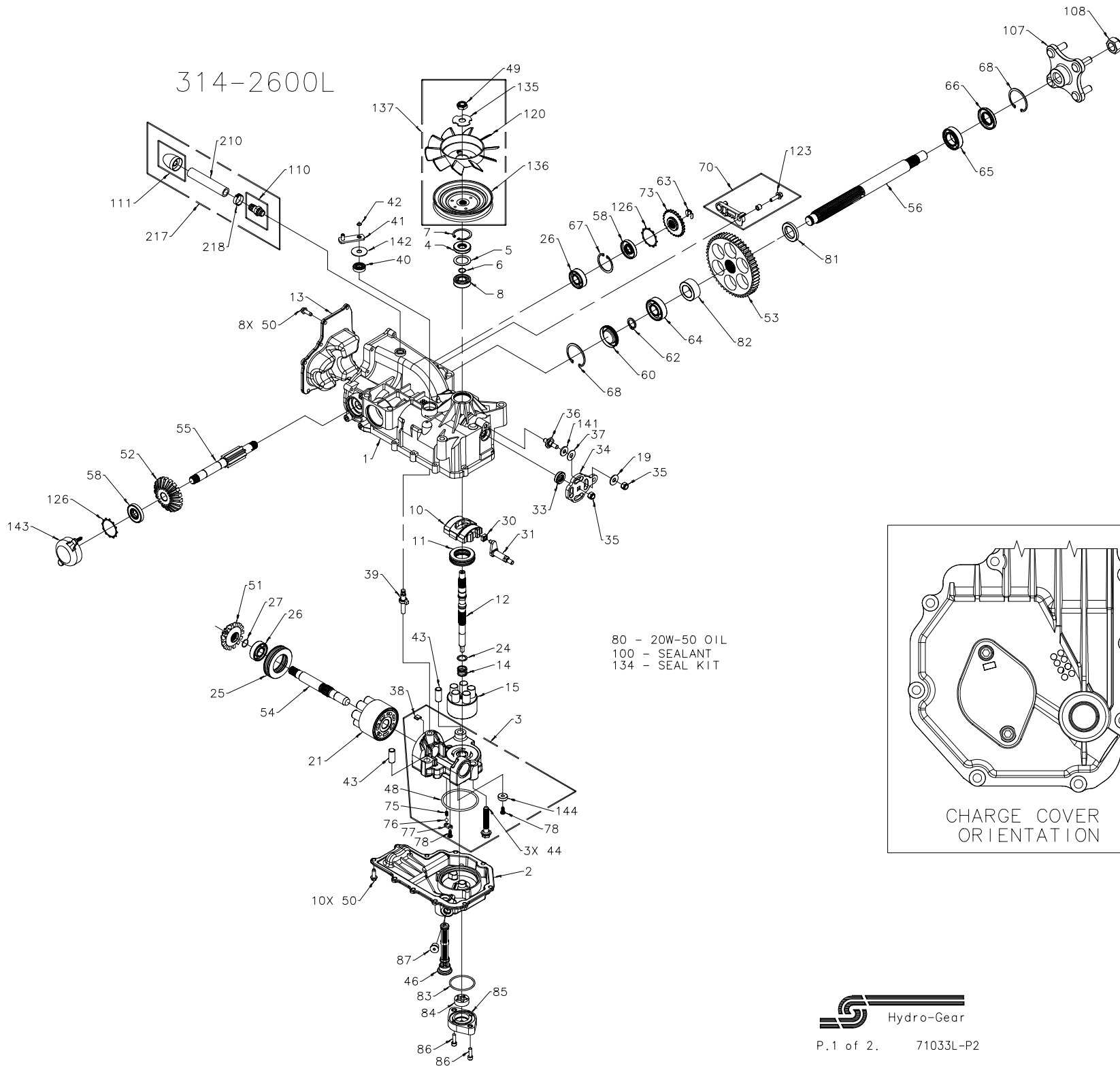

80 - 20W-50 OIL
 100 - SEALANT
 134 - SEAL KIT

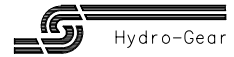
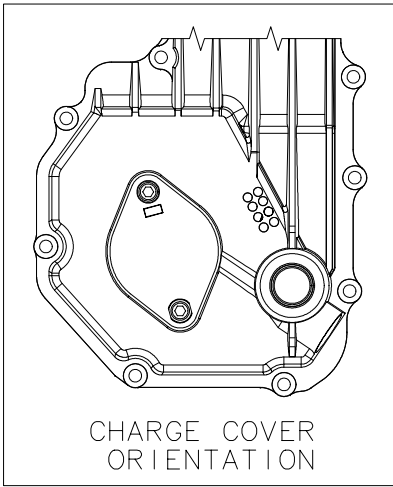

314-2600L

ITEM #	PART #	QTY	DESCRIPTION
1	70652	1	KIT, HOUSING-MAIN
		1	HOUSING, MAIN
		2	CRADLE BEARING
		1	TRUNNION BUSHING
		1	SHAFT, BRAKE
		1	SEAL, LIP 12 X 25 X 7
		1	SCREW, HFHC 1/4-28 X 7/8 (PATCH)
		1	WASHER, .34 X .88 X .03
2	51866	1	HOUSING, LOWER
3	70903	1	KIT, CENTER SECTION
		1	CENTER SECTION
		1	BUSHING .673 X 1.03 X .75
		1	PLATE, BYPASS
		3	HFHCS, 3/8-24 X 2.5 (PATCH)
		2	ASSEMBLY, SHOCK VALVE .027
		1	CHARGE RELIEF SPRING
		1	BALL, 1/4
		1	O-RING, .139 X 2.984 X 7
		1	PLATE, RELIEF
		2	BOLT, SELF-TAPPING 10-32 X .5
		1	MAGNET, RING
4	9008000-0128	1	LIP SEAL
5	2003018	1	SPACER
6	2003016	1	WIRE RETAINING RING
7	2003052	1	RETAINING RING
8	2003043	1	BALL BEARING
10	2003087	1	VARIABLE SWASHPLATE
11	50551	1	THRUST BEARING 30 X 52 X 13
12	51771	1	SHAFT, INPUT
13	50891RM	1	COVER-BACK
14	2003014	1	SPRING, BLOCK
15	70331	1	10cc CYLINDER BLOCK ASS'Y
		1	10cc CYLINDER BLOCK
		5	10cc PISTON SPRING
		5	PISTON SEAT WASHER
		5	10cc PISTON
19	44130	1	WASHER
21	70082	1	21cc CYLINDER BLOCK ASS'Y
		1	21cc CYLINDER BLOCK
		7	21cc PISTON SPRING
		7	PISTON SEAT WASHER
		7	21cc PISTON
24	2003017	1	WASHER, BLOCK THRUST
25	50552	1	THRUST BEARING 42 X 68 X 16
26	50315	2	BALL BEARING
27	2000022	1	WIRE RETAINING RING
30	2000015	1	SLOT GUIDE
31	50807	1	TRUNNION ARM
33	9008000-0126	1	LIP SEAL
34	50749	1	CONTROL ARM
35	50317	2	NUT
36	50426	1	STUD - SHORT 5/16-24
37	50281	1	FRICTION PUCK
38	70680	1	KIT, BYPASS PLATE
39	2003555	1	BYPASS ACTUATOR
40	45074	1	LIP SEAL
41	50270	1	BYPASS ARM
42	44870	1	RETAINING RING
43	50002	2	PIN
44	50016	3	SCREW
46	51931	1	ASSEMBLY, FILTER
49	51244	1	HEX LOCK NUT 1/2-20 (NYLON INSERT)
50	50752	18	SCREW, 1/4-20 X .75 LONG
51	50744	1	14T BEVEL GEAR
52	50745	1	19T BEVEL GEAR

ITEM #	PART #	QTY	DESCRIPTION
53	50746	1	53T SPUR GEAR
54	50757	1	MOTOR SHAFT
55	51298	1	BRAKE SHAFT
56	50748	1	AXLE SHAFT
58	51161	2	SEAL, LIP 17 X 40 X 7
60	50995	1	SEAL PLUG - SIDE
62	50759	1	RETAINING RING - AXLE
63	51109	1	RETAINING RING
64	50743	1	BEARING-BALL 20X47X14(6204)
65	50740	1	BEARING-BALL 25X47X12(6005)
66	50751	1	SEAL
67	50329	1	RETAINING RING
68	50760	2	RETAINING RING-AXLE
70	71087	1	LH, BRAKE ARM SERVICE ASSEMBLY
		1	BRAKE ARM
		1	CLEVIS PIN
		1	BUSHING .255 X .381 X .330
		1	SCREW, HFHC 1/4-20 X 7/8 (PATCH)
73	50754	1	BRAKE DISC
80		79oz	20W-50 OIL
81	51939	1	SPACER 1.04 X 1.65 X .22
82	51940	1	SPACER 1.04 X 1.65 X .70
83	9004101-1340	1	O-RING .103 X 1.862
84	50273	1	ASSEMBLY, GEROTOR
85	50260	1	COVER GEROTOR
86	50095	2	SHCS M6 X 20
87	9005110-5600	1	PLUG, 9/16-18 (METAL)
100	50928	1	SEALANT
107	70314	1	HUB ASSEMBLY
		1	HUB
		4	LUG BOLT
108	50863	1	NUT, HEX 3/4-16
110	70110	1	FITTING O-RING ASSEMBLY
		1	PLASTIC HOSE FITTING
		1	O-RING .08 X .468
111	70921	1	CAP-VENT ASSEMBLY
		1	CAP-POPPET VALVE
		1	ST .5 BARB VENT
120	51434	1	PULLEY, 4.79 INCH
123	51576	1	SCREW, HFHC 1/4-20 X 7/8 (PATCH)
126	51316	2	RING, RETAINING
134	70553	1	KIT, SEAL
		1	SEAL, LIP 15 X 35 X 7
		1	RING, RETAINING 37 INT
		1	SEAL, LIP 12 X 25 X7
		1	SEAL, LIP 10 X 25 X 7
		1	RING, RETAINING .31 EXT
		18	HFHCS 1/4-20 X .75
		1	SEAL PLUG
		2	RING, RETAINING .75 EXT
		1	RING, RETAINING .440 EXT
		1	SEAL, LIP 25 X 47 X 7
		1	RING, RETAINING 1.56 INT
		2	RING, RETAINING 1.87 INT
		2	RING, RETAINING 1.43
135	51523	1	WASHER, OD SLOTTED .53 X 1.63 X .06
136	51362	1	FAN, 6", 10 BLADE
137	71032	1	KIT, FAN-PULLEY
		1	WASHER, OD SLOTTED .53 X 1.63 X .06
		1	FAN, 6", 10 BLADE
		1	HEX LOCK NUT 1/2-20 (NYLON INSERT)
		1	PULLEY, 4.79 INCH

ITEM #	PART #	QTY	DESCRIPTION
141	51575	1	WASHER .34 X .88 X .03
142	51813	1	WASHER .39 X 1.27 X .05
143	51774	1	CAP, BRAKE
144	51100	1	MAGNET, RING
210	51401	1	HOSE Ø.50 X 4.00
217	71004	1	KIT, BREATHER ASSEMBLY
		1	FITTING, O-RING ASSEMBLY
		1	CAP VENT ASSEMBLY
		1	HOSE, Ø.50 X 4.00
218	50590	1	PINCH CLAMP, SINGLE EAR, 13/16
		1	PINCH CLAMP, SINGLE EAR, 13/16

