

187776
311-0410

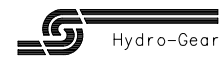
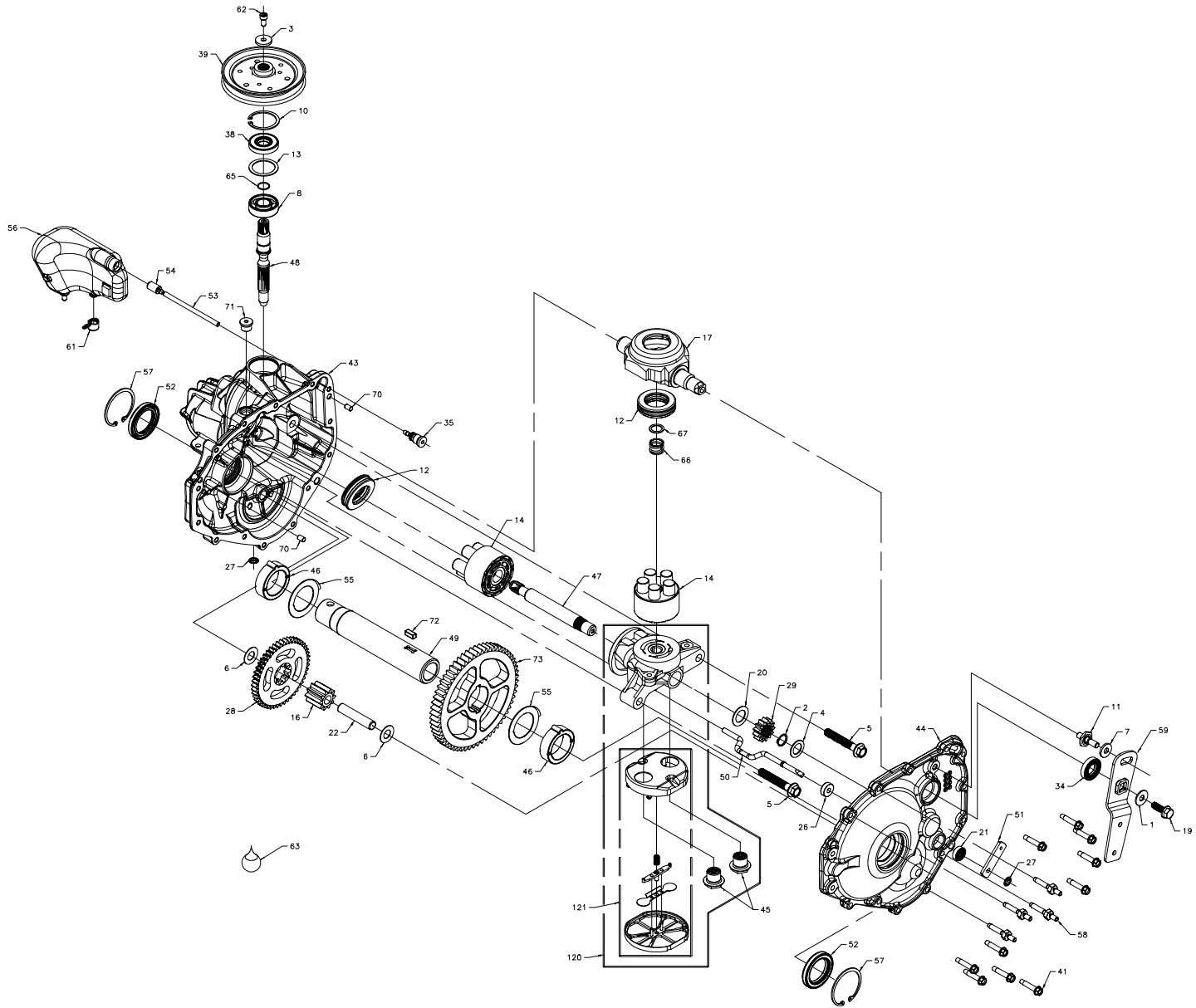

187776
311-0410

ITEM	PART #	QTY	DESCRIPTION
1	44130	1	FLAT - WASHER 11/32 ID X 7/8 OD
2	44145	1	RETAINING RING
3	44278	1	WASHER, 7/8 OD X .260 ID X 1/8 THK
4	44371	1	FLAT WASHER 5/8 ID X 1.0 OD X .05 THK
5	50016	2	HYDRO MTG SCREW 3/8-24 X 2.5 LONG
6	50132	2	WASHER, HT .5 ID X 1 OD X .032
7	50281	1	PUCK, FRICTION
8	50315	1	BALL BEARING 17MM ID X 40MM OD X 12MM
10	50329	1	RING, RETAINING
11	50426	1	STUD 5/16-24
12	50551	2	BEARING, THRUST 30 X 52 X 13
13	50951	1	SPACER
14	70331	2	BLOCK - CYLINDER
		10	SPRING, COMPRESSION
		10	WASHER - THRUST
		10	PISTON
16	51043	1	GEAR, 10T JACK SHAFT
17	51048	1	SWASHPLATE, TRUNNION MACHINED
19	51064	1	BOLT, HEX FLANGE HEAD 5/16-24 X .94 (PATCH)
20	51069	1	WASHER, MOTOR SHAFT .71 ID X 1.6 OD X .04 THK
21	51081		LIP SEAL .250 X .750 X .250 TC
22	51083	1	PIN, JACKSHAFT
26	51100	1	MAGNET, RING
27	51116	2	RETAINING RING .250 EXTERNAL
28	51129	1	10T / 48T GEAR
29	51130	1	GEAR - PINION 13T
34	51140	1	LIP SEAL 18 X 32 X 7
35	51143	1	FITTING 5/16 SAE, 5/32 TUBE
36	51144	1	O-RING .103 X .299 ID
37	51147	1	HOSE, EXPANSION TANK
38	51161	1	SEAL, LIP 17 X 40 X 7
39	51182	1	PULLEY Ø4.40 X .665
40	51186	10.5 OZ	SEALANT
41	51190	10	HEX WASHER SCREW 1/4-20 X 1.125
42	51208	1	CENTER SECTION
		1	BUSHING .707 X .786 X .591
43	70830	1	MAIN HOUSING ASSEMBLY
		1	HOUSING, MAIN
		1	BUSHING .865 X .985 X .790
44	70831	1	SIDE HOUSING ASSEMBLY
		1	HOUSING, SIDE
		1	BUSHING .624 X .719 X .562
		1	BUSHING .865 X .985 X .790
45	51485	2	PLUG, CHECK .027 WASHER SPRING
46	51658	2	BEARING, SLEEVE (INBOARD)
47	51661	1	SHAFT, MOTOR
48	51662	1	SHAFT, INPUT
49	51665	1	TUBE-BULL GEAR WELDED ASSEMBLY
50	51668	1	ROD, BYPASS ACTUATOR
51	51669	1	ARM, BYPASS
52	51671	2	SEAL, LIP 1.220 X 1.929 X .276
53	51672	1	HOUSE, EXPANSION TANK 3/16

ITEM	PART #	QTY	DESCRIPTION
54	51674	1	WEIGHT, Ø5/32 BARBED
55	51675	2	WASHER, 2.225 X 1.280 X .138
56	52067	1	TANK, EXPANSION
57	51678	2	RING, RETAINING
58	52041	4	STUD, 1/4-20 X 1 SELF TAP, 1/4-20 X .75
59	51680	1	ARM, CONTROL
61	51687	1	CAP, BARBED EXPANSION
62	51546	1	SCREW, SOCKET HEAD CAP M6 X 1.0-12 (PATCH)
63		48OZ	OIL, DRIVE CLEAN 5W30
65	2000022	1	RING, RETAINING
66	2003014	1	SPRING, HELICAL COMPRESSION
67	2003017	1	WASHER
70	9004800-2506	2	PIN, STRAIGHT HEADLESS
71	9005110-5600	1	PLUG, STRAIGHT THREAD SOCKET HEAD
120	70829	1	CENTER SECTION - FILTER - BYPASS ASSEMBLY
		1	CENTER SECTION
		2	PLUG, CHECK .027 WASHER SPRING
		1	KIT, FILTER
121	71029	1	KIT, FILTER
		1	FILTER
		1	FILTER BASE
		1	DEFLECTOR
		1	SPRING, BYPASS
		1	BYPASS ACTUATOR
122	70832		KIT, SEAL - O-RING
		1	LIP SEAL .250 X .750 X .250 TC
		1	LIP SEAL 18 X 32 X 7
		1	O-RING .103 X .299 ID
		2	SEAL, LIP 1.220 X 1.929 X .276
		1	SEAL, LIP 17 X 40 X 7
128	70833	1	KIT, EXPANSION TANK
		1	CAP, BARBED EXPANSION
		1	HOSE, EXPANSION TANK
		1	CLUNKER
		1	RETAINING RING .250 EXTERNAL
129	51252	1	CAP, EXPANSION TANK SHIPPING