

1001321  
334-3000

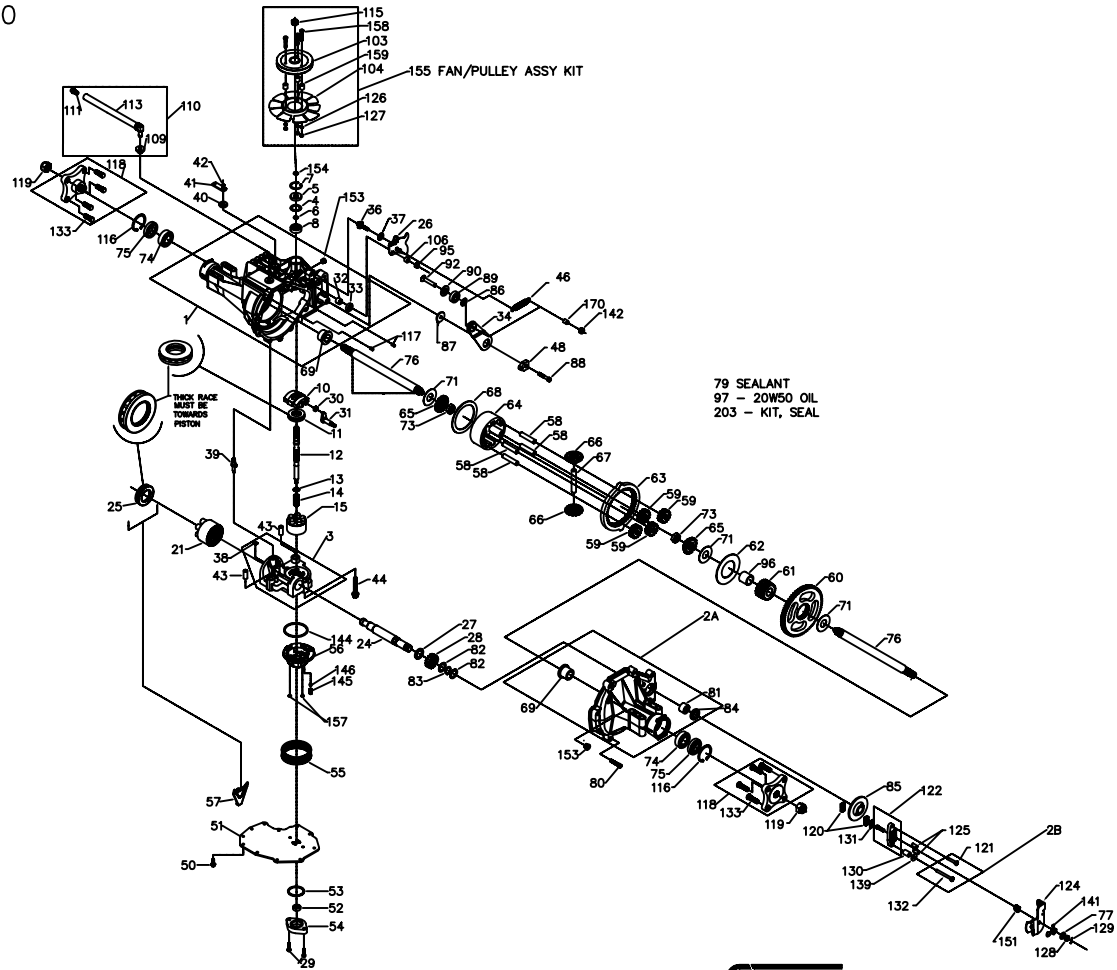

EON #8

5

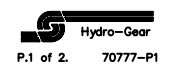

1001321  
334-3000

ITEM #	PART #	QTY	DESCRIPTION
1	70433	1	MAIN HOUSING ASSEMBLY
		1	MAIN HOUSING
		1	LIP SEAL
		1	FLANGE BEARING
		1	TRUNNION BUSHING
		2	CRADLE BEARING
2A	71120	1	R.H. HOUSING ASSEMBLY
		1	R.H. HOUSING
		1	FLANGE BEARING
		1	NEEDLE BEARING (SCE1412)
		1	LIP SEAL (.875I.D.x1.30.D.x.25)
2B	71139	1	KIT, BRAKE BOLT
		1	BOLT, HEX HD 1/4-20 X 1.25 W/PATCH
		1	BOLT, HEX HD 1/4-20 X 2.25 W/PATCH
3	70683	1	CENTER SECTION ASSEMBLY
		1	CENTER SECTION
		1	BUSHING .50X.60X.50
		1	BUSHING .90X1.02X.75
		1	PLATE, BYPASS
		2	CHECK PLUG ASSEMBLY, .027
4	2003018	1	SPACER
5	9008000-0128	1	SEAL-LIP
6	2003016	1	WIRE RETAINING RING
7	2003052	1	RETAINING RING
8	2003043	1	BALL BEARING
10	2003087	1	VARIABLE SWASHPLATE
11	50551	1	THRUST BEARING 30 X 52 X 13
12	50795	1	INPUT SHAFT
13	2003017	1	BLOCK THRUST WASHER
14	2003014	1	BLOCK SPRING
15	70331	1	10cc CYLINDER BLOCK ASSEMBLY
		1	10cc CYLINDER BLOCK
		5	10cc PISTON
		5	10cc PISTON SPRING
		5	PISTON SEAT WASHER
21	70082	1	21cc CYLINDER BLOCK ASSEMBLY
		1	21cc CYLINDER BLOCK
		7	PISTON SEAT WASHER
		7	21cc PISTON
		7	21cc PISTON SPRING
24	50662	1	OUTPUT (MOTOR) SHAFT
25	50552	1	THRUST BEARING 42 X 68 X 16
26	51564	1	CONTROL ARM
27	50774	1	SPACER
28	50661	1	16T PINION GEAR
29	50975	2	CAPSCREW, M6 X 1-25
30	2000015	1	SLOT GUIDE
31	50807	1	TRUNNION ARM
32	2003009	1	TRUNNION BUSHING
33	9008000-0126	1	LIP SEAL
34	51565	1	RETURN ARM
36	50426	1	STUD 5/16-24
37	50281	1	PUCK, FRICTION
38	70680	1	KIT, BYPASS PLATE
39	2003555	1	BYPASS ACTUATOR
40	45074	1	LIP SEAL
41	44866	1	BYPASS ARM
42	44870	1	RETAINING RING
43	50002	2	PIN
44	50016	3	SCREW
46	51566	1	RETURN SPRING
48	51097	1	ADJUSTING PUCK

ITEM #	PART #	QTY	DESCRIPTION
50	50752	11	SCREW, 1/4-20 X .75
51	50972	1	LOWER COVER
52	50273	1	GEROTOR ASSEMBLY
53	9004101-1340	1	O-RING
54	50260	1	GEROTOR COVER
55	70538	1	KIT, FILTER
56	51156	1	CHARGE MANIFOLD
57	50796	1	RETAINER, MOTOR BEARING
58	50776	4	PIN, CARRIER
59	50763	4	15T PLANET GEAR
60	50646	1	67T SPUR GEAR
61	50645	1	21 TOOTH SUN GEAR
62	50769	1	PLANET THRUST PLATE
63	50764	1	51T RING GEAR
64	50765	1	PLANETARY CARRIER
65	50647	2	MITER GEAR, DIFF. (SPLINED)
66	50648	2	MITER GEAR, DIFF.
67	50766	1	SHAFT, DIFFERENTIAL
68	50767	1	DIFF. THRUST PLATE
69	50768	2	FLANGE BEARING
71	50788	3	WASHER 1.0 X 2.25 X .04
73	50791	2	HEX JAM NUT, 5/8-18
74	50771	2	BALL BRG 6205-1
75	50772	2	SEAL 1"ID x 2.0472" x 0.375"
76	50825	2	SHAFT, AXLE
77	44130	1	WASHER
79	50928	1	SEALANT
80	50868	9	TORX HEAD SCREW, 5/16-18
81	44752	1	NEEDLE BEARING (SCE1412)
82	50777	2	WASHER
83	50775	1	RETAINING RING
84	50773	1	LIP SEAL (.875 I.D. X 1.3 O.D. X .25)
85	50779	1	BRAKE DISK
86	50132	1	WASHER .5 X 1.0 X .03
87	50836	1	WASHER .32 X 2.02 X .14
88	50837	1	SCREW, 5/16-24 X 1.5
89	44147	1	BEARING
90	51200	1	SPACER, LOCATING
92	51567	1	COUNTERSUNK SCREW 5/16 -18 X 1.75
95	50108	1	HEX LOCK NUT 5/16-24
96	50866	1	SLEEVE BEARING
97		122 OZ	OIL-20W50 BLN-50283
103	50302	1	PULLEY
104	50307	1	FAN
106	50850	1	SPACER, TRUNNION
109	50133	1	BUSHING, RUBBER
110	70776	1	FITTING KIT
		1	BUSHING, RUBBER
		1	CAP-VENT ASSEMBLY
		1	HOSE/FITTING ASSEMBLY
111	70109	1	CAP-VENT ASSEMBLY
		1	PLASTIC VENT
		1	CAP-VENT
113	70775	1	HOSE/FITTING ASSEMBLY
		1	FITTING, 90°
		1	#1/2 HOSE, 8.75" LONG
		1	PINCH CLAMP
115	44133	1	HEX NUT 1/2-20
116	50859	2	RETAINING RING
117	9004800-2506	2	STD HDLS PIN
118	70314	4	HUB ASSEMBLY
		4	WHEEL STUD, 1/2-20
		1	HUB

ITEM #	PART #	QTY	DESCRIPTION
119	50863	2	NUT, HEX 3/4-16
120	44132	2	PUCK, BRAKE
121	51927	1	BOLT, HEX HD 1/4-20 X 1.25 W/PATCH
122	70633	1	YOKE, BRAKE ASSEMBLY
124	50916	1	ARM, BRAKE
125	44127	2	PINS, BRAKE
126	43177	3	LOCKWASHER, 1/4"
127	43178	3	NUT, 1/4-20
128	44142	1	NUT, CASTLE
129	44101	1	COTTER PIN
130	23711	1	SPACER
131	44134	1	PUCK PLATE
132	51928	1	BOLT, HEX HD 1/4-20 X 2.25 W/PATCH
133	44431	8	WHEEL STUD 1/2-20
139	44278	1	WASHER, 7/8OD X .265ID X .125 THK
141	50884	1	SPRING, BRAKE ARM BIAS
142	43064	1	HEX LOCK NUT, 5/16-18
144	50974	1	O-RING, 2.987 X 0.103
145	51157	1	SPRING, RELIEF
146	9001214-4400	1	BALL, 7/16
151	50919	1	COMP. SPRING, BRAKE ANTI-DRAG
153	9005110-5600	1	PLUG, STRAIGHT THREAD
155	70243	1	FAN/PULLEY ASSY KIT
		1	PULLEY
		1	FAN
		3	SCREW
		3	NUT
		3	LOCK WASHER
		3	SPACER
		1	NUT
		2	O-RING, 0.070X0.239
157	50977	1	SPACER, TUBE
170	51568	1	KIT, SEAL
203	70492	1	SEAL-LIP
		1	SEAL-LIP
		1	SEAL-LIP
		1	O-RING
		2	SEAL 1" ID X 2.0472" X .375"
		1	LIP SEAL (.875 I.D.X1.3 O.D. X.25)
		2	O-RING, .070X.239
		2	SCREW O-RING
		1	KIT, O-RING, MANIFOLD

