

For Husqvarna Parts Call 606-678-9623 or 606-561-4983

 **Husqvarna**

Workshop manual

250 PS



For Husqvarna Parts Call 606-678-9623 or 606-561-4983

Technical specification

Engine

Cylinder volume	cm ³	49
Cylinder diameter	mm	44
Stroke	mm	32
Idle speed	rpm	2 500
Max. recommended speed	rpm	11 000

Hydraulic transmission

Hydraulic motor capacity	cm ³ /rev	1,4
Hydraulic pump capacity	cm ³ /rev	1,2
Working pressure, high pressure hose	MPa	6-9
Pulse pressure, high pressure hose	MPa	9
Pressure in return hose	Mpa	0,2-0,8
Flow	l/min	2-13

Ignition system

Manufacturer/type of ignition system		Electrolux, ET
Spark plug	mm	Champion RCJ7Y
Electrode gap		0,5

Fuel/Oil system

Manufacturer/type of carburettor		Walbro/HDA 86
Fuel tank capacity litre	liter	0,9
Hydraulic oil tank capacity	liter	1,3
Method of chain lubrication		Automatic

Weight

Engine unit without cutting attachment	kg	7,0
--	----	-----

Cutting attachment

Shaft length	m	2-3-4-5-6
Weight	kg	2,2-2,4-2,9-3,5-4,0
Bar length	inch/cm	6/16
Pitch	inch	3/8
Thickness of drive links	mm	1,3

Husqvarna 250 PS

<i>Chapter</i>	<i>Page</i>
1. Service data	4
2. Starter unit	12
3. Fuel system	14
4. Throttle lock	24
5. Ignition system	25
6. Clutch	28
7. Cylinder and piston	30
8. Crankcase and crankshaft	33
9. Hydraulics	38

1. Service data

Remember...

...never start the pruning saw if the hydraulic oil tank or hoses/shaft are not fitted. If the hydraulic oil tank is not fitted the clutch may come loose and cause injury. If the hoses or shaft are not fitted the engine cannot be revved up and the hydraulic pump and clutch may be damaged.

...the pressure relief valve in the hydraulic motor must open if there is a blockage in the return hose. If it opens without reason then it must be replaced. (See page 45.)

...you must be able to turn the pulley on the starter unit at least a further 1 1/2 turns when the starter cord is fully extended.

...do not use the pruning saw until it has been properly adjusted or repaired.

...the pruning saw is fitted with an electronic ignition system. This produces a powerful spark with a short burn time. If the performance of the pruning saw is poor, if the saw is difficult to start, or if it idles unevenly, first check the spark plug before taking any other action.

...the pruning saw consists of an engine unit and a hydraulic unit. It is often easier to handle the pruning saw when the hydraulic oil tank has been separated from the engine unit. (See page 38.)

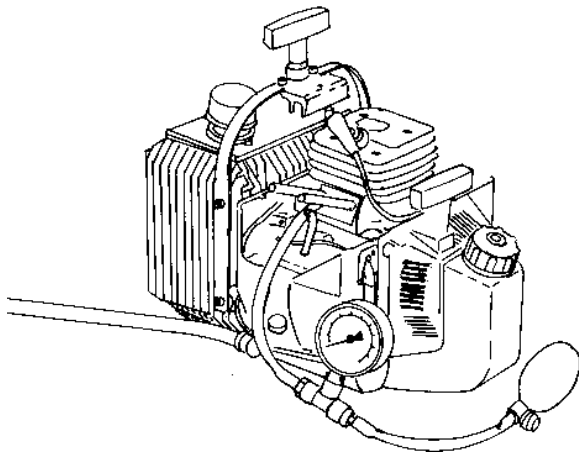

Leak testing

Crankcase, cylinder

Remove the silencer, air filter and carburettor assembly. Use the carburettor bolts and spacers 502 50 45-01 to attach cover plate 502 50 72-01 to the inlet side of the cylinder. Attach cover plate 502 50 71-01 to the exhaust side of the cylinder. Use pressure tester 502 50 38-01.

Pressure: 0.08 MPa (0.8 kp/cm²)

Max. leakage: 0.02 MPa in 30 sec. (0.2 kp/cm² in 30 sec.)

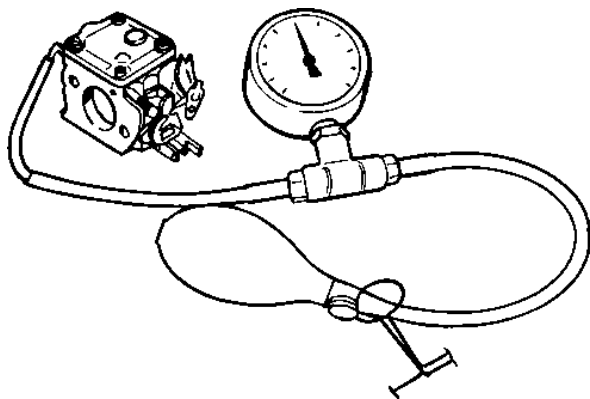

Leak testing

Carburettor

Remove the carburettor from the pruning saw. Connect the hose of the pressure tester to the fuel hose nipple on the carburettor.

Pressure: 0.03 MPa (0.3 kp/cm², 4.3 psi)

Leakage: no leakage is permitted.

Tools: 502 50 38-01 Pressure tester

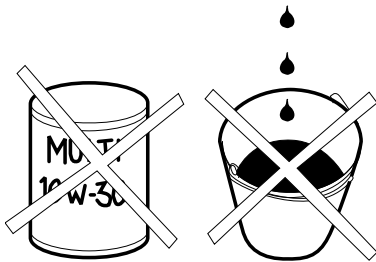
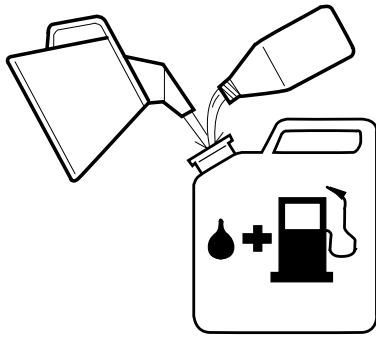

Fuel



WARNING! The pruning saw is equipped with a two-stroke engine and should always be run on a mixture of petrol and two-stroke oil. To ensure the correct mixture always measure out the amount of oil that is needed accurately. If you mix small amounts of fuel small errors in the amount of oil will have a large effect on the mixture ratio. Always ensure good ventilation when mixing fuel.

Petrol

Use good quality unleaded or leaded fuel. The minimum recommended octane is 90. If the fuel is less than 90 octane it may cause knocking. This will lead to a higher engine temperature and may result in severe engine damage.

Two-stroke oil

For best results use Husqvarna two-stroke oil, which is specially developed for pruning saws. Mixture ratio: 1:50 (2%).

If Husqvarna two-stroke oil is not available you may use another high quality two-stroke oil made for air-cooled engines.

Mixture ratio: 1:33 (3%) - 1:25 (4%).

Never use outboard oil, i.e. oil intended for water cooled outboard engines.



Never use oil designed for four-stroke engines.

Mixing

Always mix petrol and oil in a clean container designed for petrol.



Start by pouring half the petrol into the container. Then add all the oil. Shake the fuel mixture well. Now add the remaining petrol. Shake the fuel mixture thoroughly. Then pour the fuel into the fuel tank of the pruning saw. Never mix more fuel than you need for around 2 months work. If you do not intend to use the pruning saw for a long period the fuel tank should be drained and cleaned.

The table on the left shows the various mixture ratios.



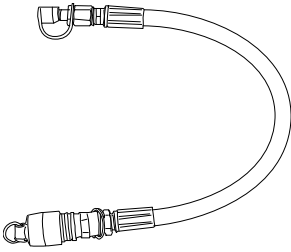

 Gasolin Benzin Essence Gasolina Lit.	 Oil • Öl Huile • Aceite Lit.		
	2%(1:50)	3%(1:33)	4%(1:25)
5	0,10	0,15	0,20
10	0,20	0,30	0,40
15	0,30	0,45	0,60
20	0,40	0,60	0,80
US gallon	US fl. oz.		
	2%(1:50)	3%(1:33)	4%(1:25)
1	2 1/2	3 3/4	5 1/8
2 1/2	6 1/2	9 3/4	12 7/8
5	12 7/8	19 1/4	25 3/4

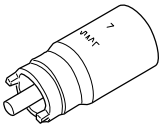
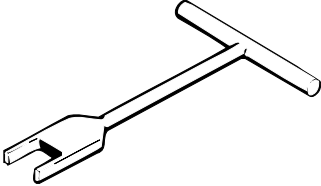
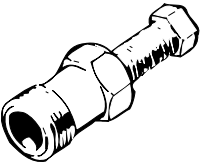
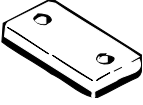
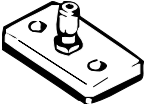
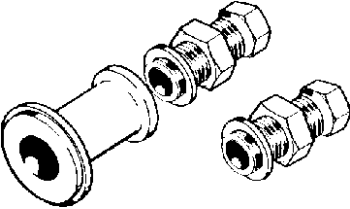
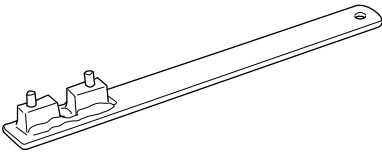
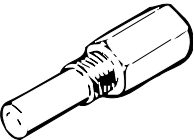
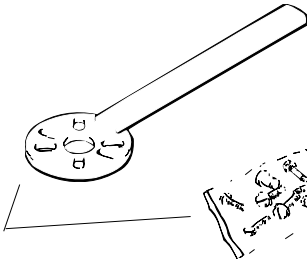
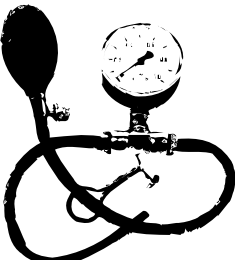
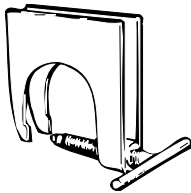
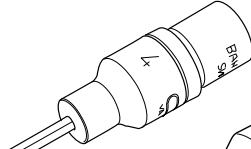
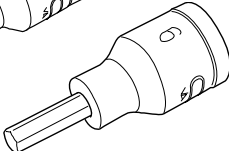
1

Tools

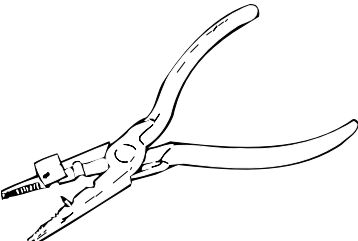
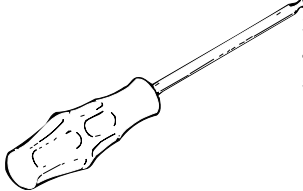
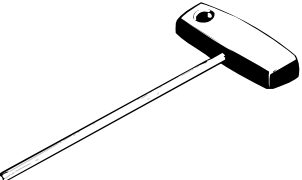
	<p>502 42 45-01 Test hose</p>		<p>502 50 46-01 Spacer</p>
	<p>502 42 50-01 Tool for pressure relief valve</p>		<p>502 50 66-02 U key</p>
	<p>502 50 26-01 Puller</p>	 	<p>502 50 71-01 Cover plate, exhaust</p> <p>502 50 72-01 Cover plate, inlet</p>
	<p>502 50 30-12 Crankshaft fitting tool</p>		<p>502 52 16-01 Locking tool for clutch drum</p>
	<p>502 50 33-01 Piston plug</p>		<p>502 51 49-01 Key</p> <p>502 51 54-01 Bolts for key</p>
	<p>502 50 38-01 Pressure tester assy.</p>		<p>502 51 61-01 Tool for removing crankcase and crankshaft</p>
		 	<p>4 mm 6 mm</p> <p>502 52 13-01 502 52 14-01 Allen key with square socket</p>

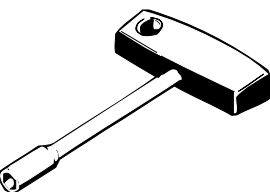
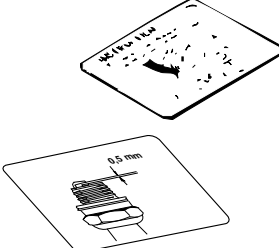
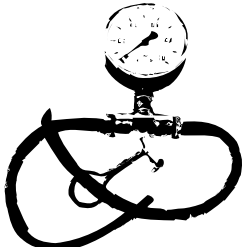
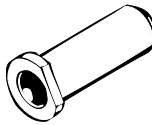
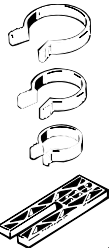
Tools

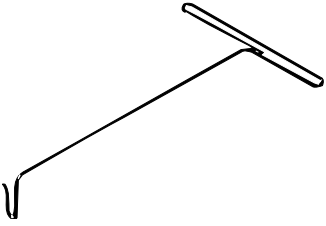
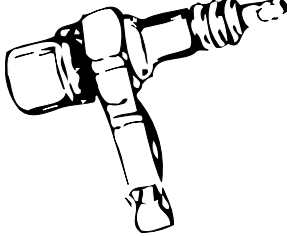
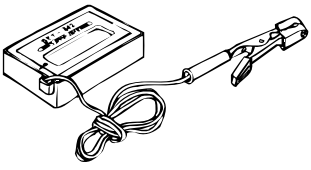
	<p>502 50 06-01 Pliers, ignition cable</p>	 <p>3 mm 4 mm 5 mm</p>	<p>502 50 86-01 502 50 87-01 502 50 88-01 Allen screwdriver with ball</p>
	<p>6 mm 4 mm 3 mm 3/6" 5 mm 502 50 16-01 502 50 18-01 502 50 19-01 502 50 57-01 502 50 64-01 Allen key</p>		<p>502 50 91-02 Touch-up paint, orange</p>
	<p>8 mm 10 mm 502 50 22-01 502 50 23-01 Socket spanner</p>	 <p>0,3 mm 0,5 mm</p>	<p>502 51 34-02 Feeler gauge 502 51 91-01 Feeler gauge</p>
	<p>502 50 37-01 Vacuum tester</p>		<p>502 50 79-01 Mandrel for sealing ring</p>
	<p>502 50 70-01 Assembly kit for cylinder assy.</p>		<p>502 70 09-01 Pressure tester bulb</p>
	<p>502 50 83-01 Hook for tank</p>		<p>502 71 13-01 Test plug</p>
			<p>502 71 14-01 Tachometer</p>

1

Bolt torques

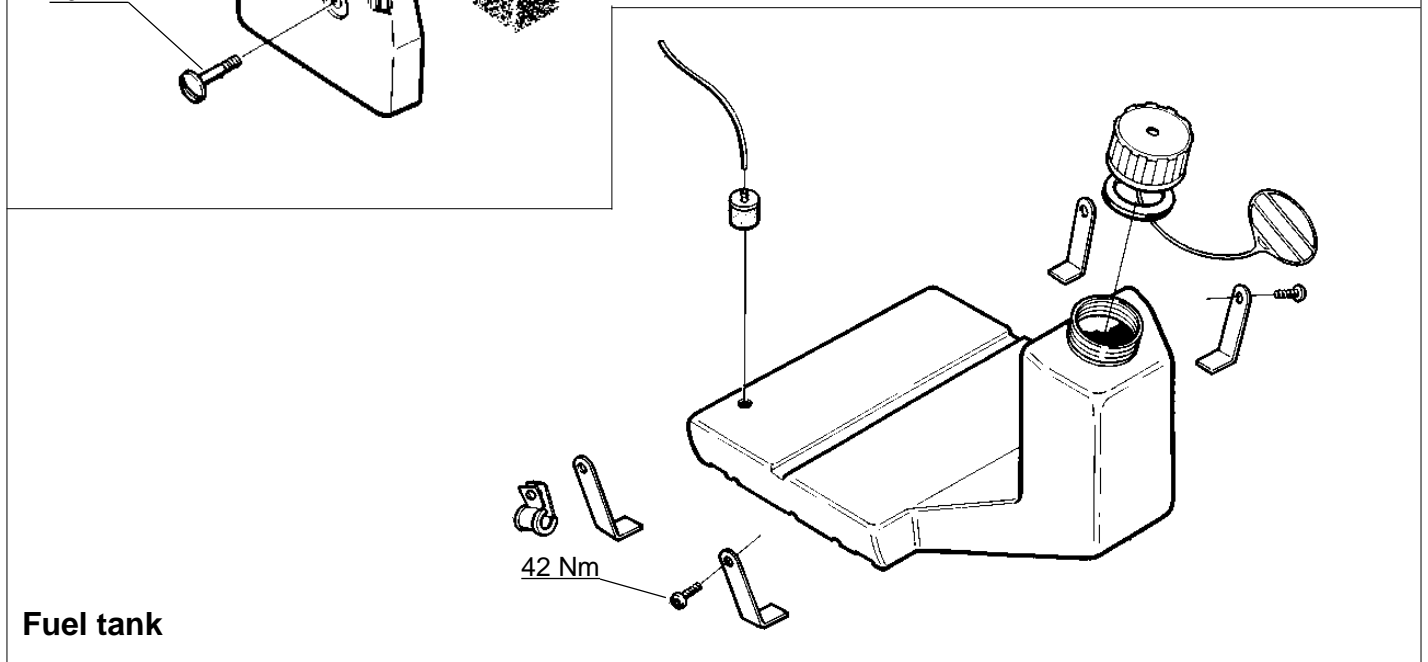
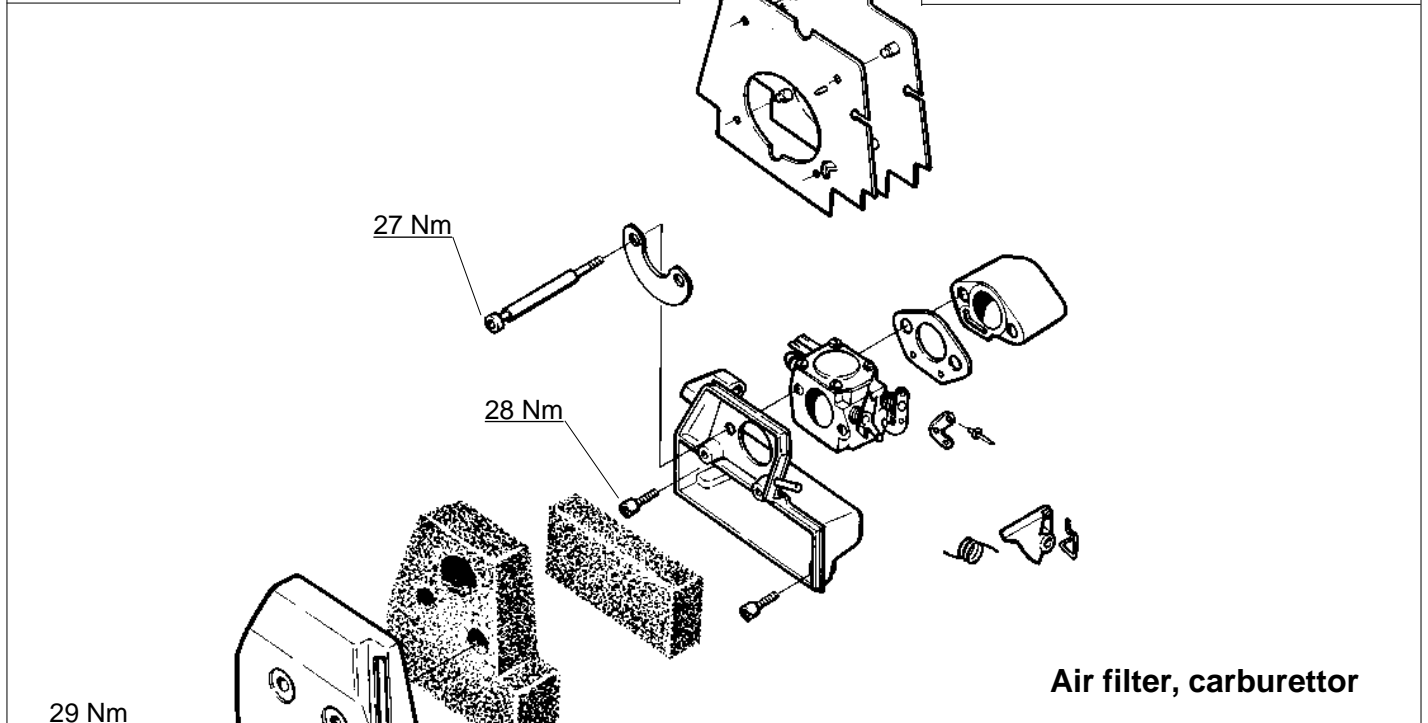
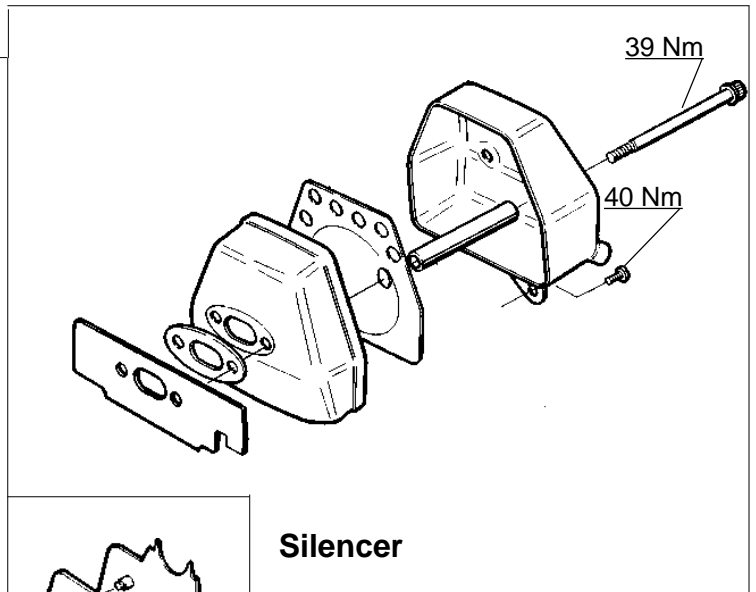
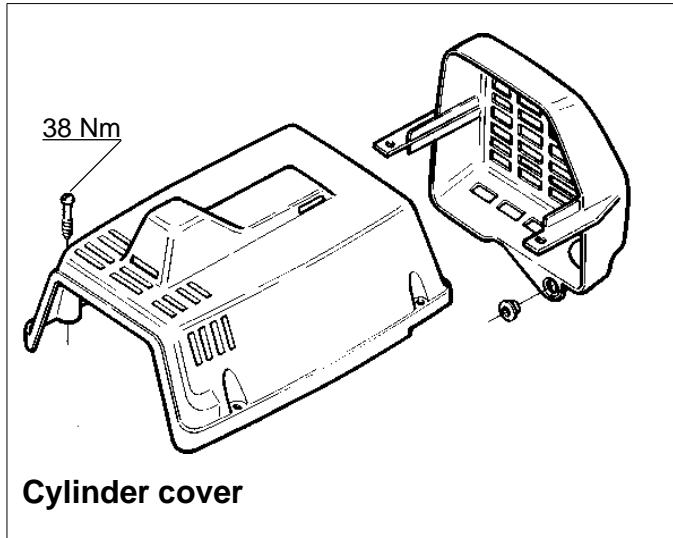

Bolt torques

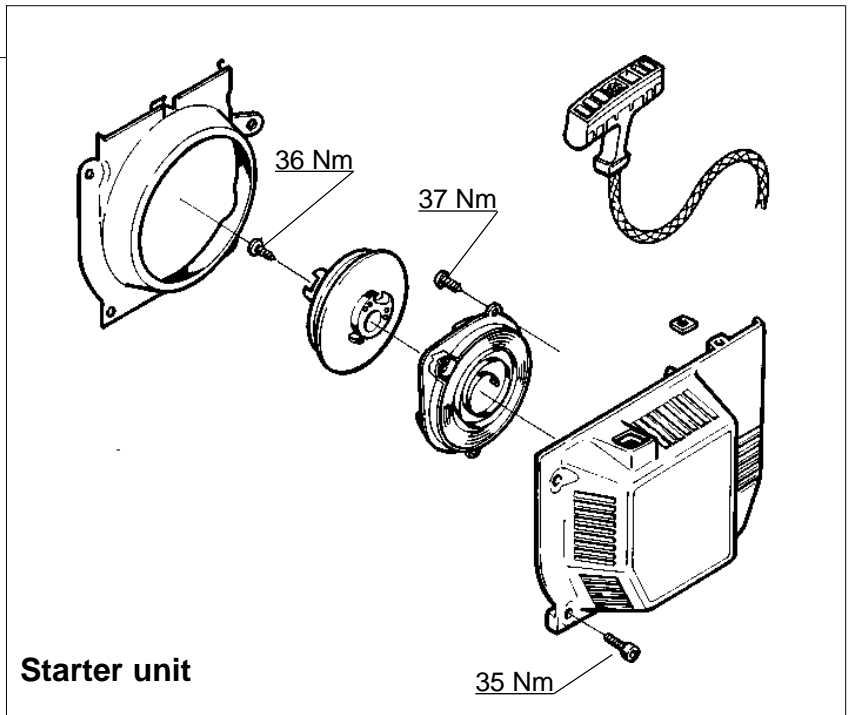
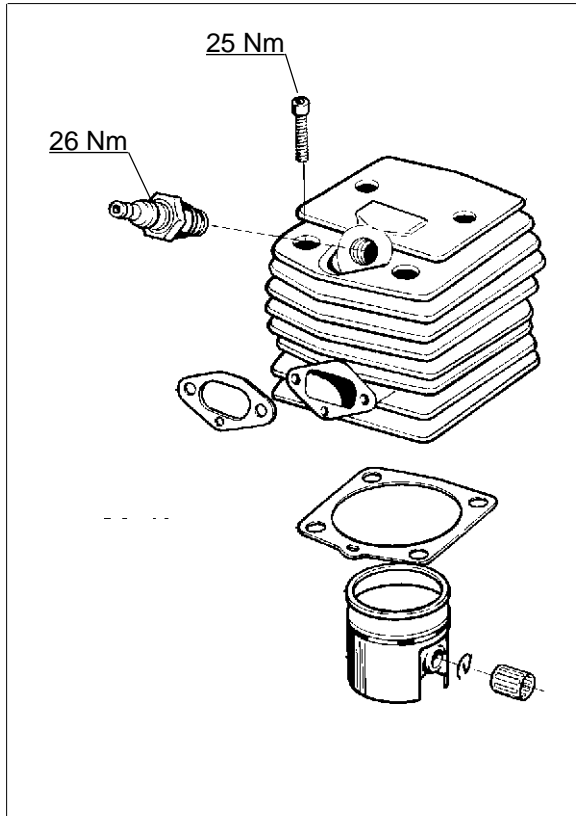

Starter unit

Cylinder, piston

Crankcase, crankshaft

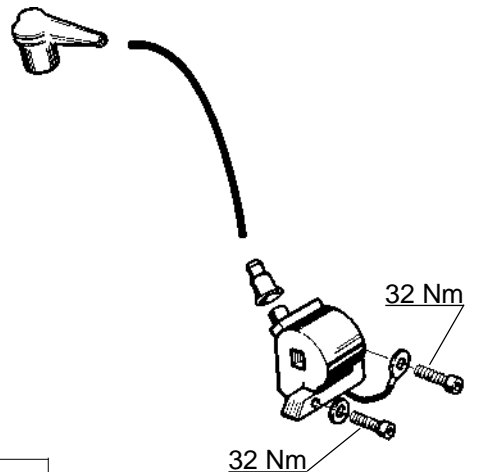
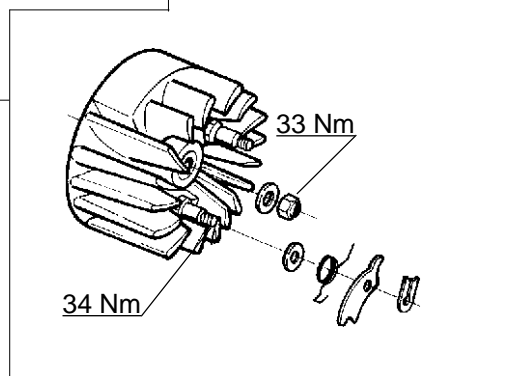

Flywheel, ignition module

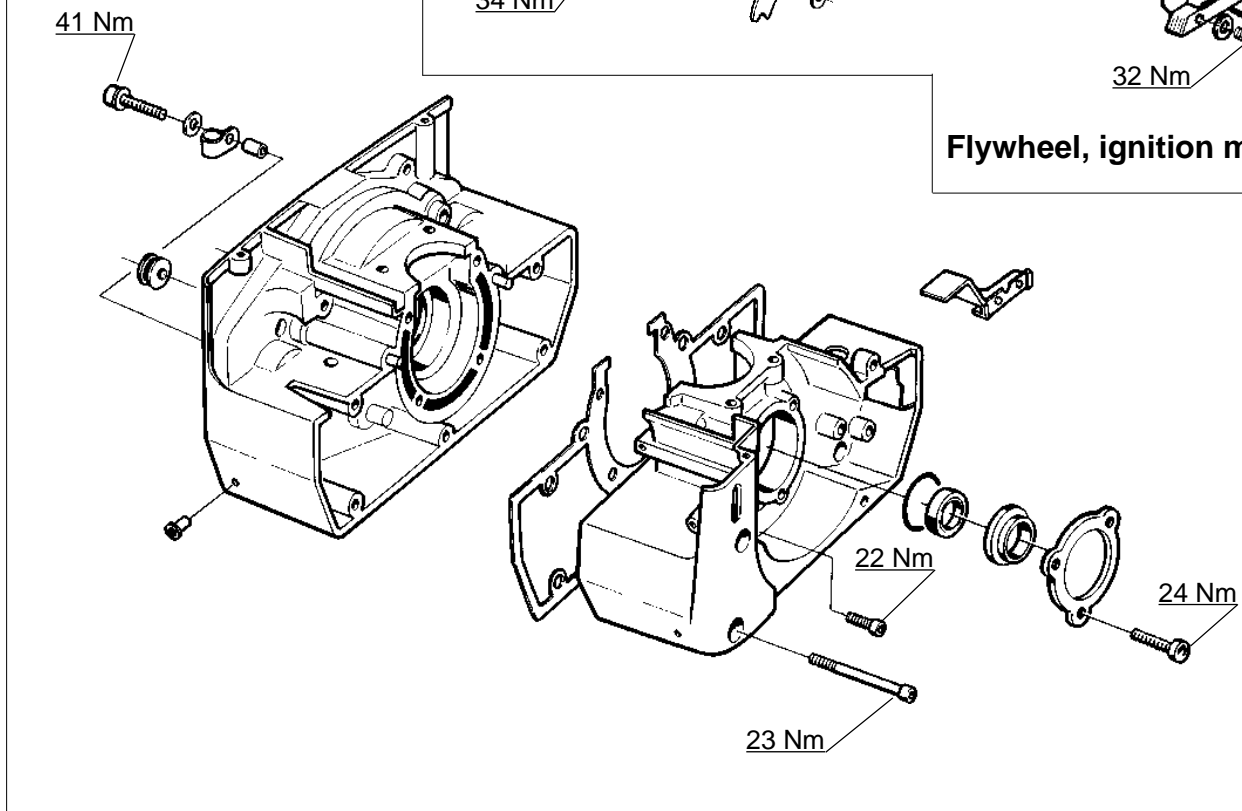

1

Bolt torques

Hydraulic oil tank

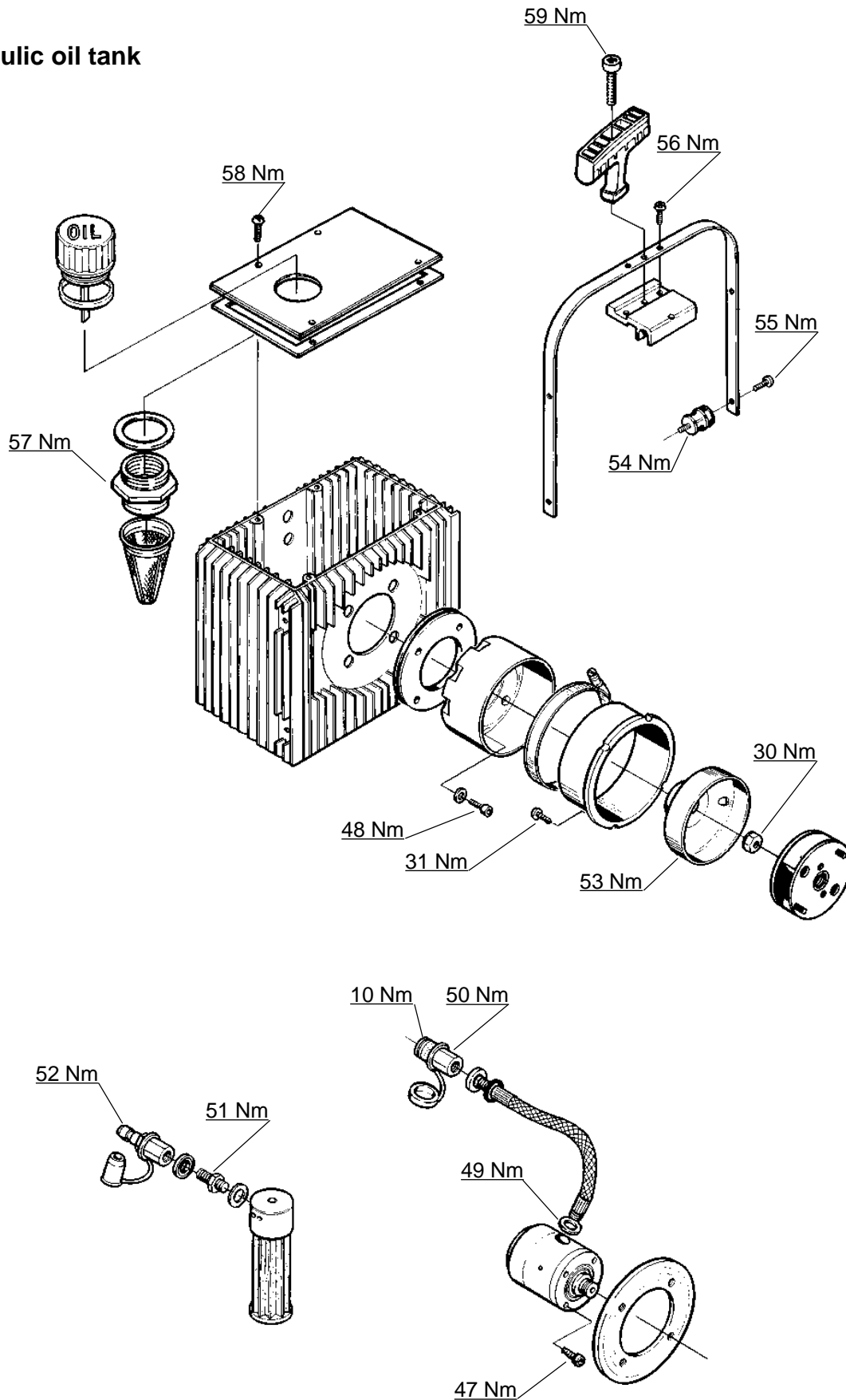

Bolt torques

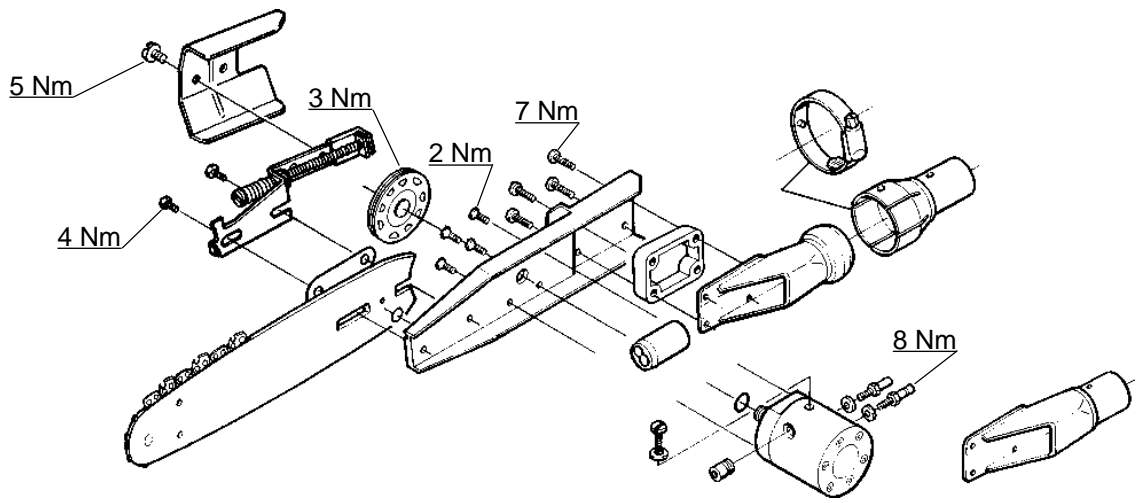

Bar

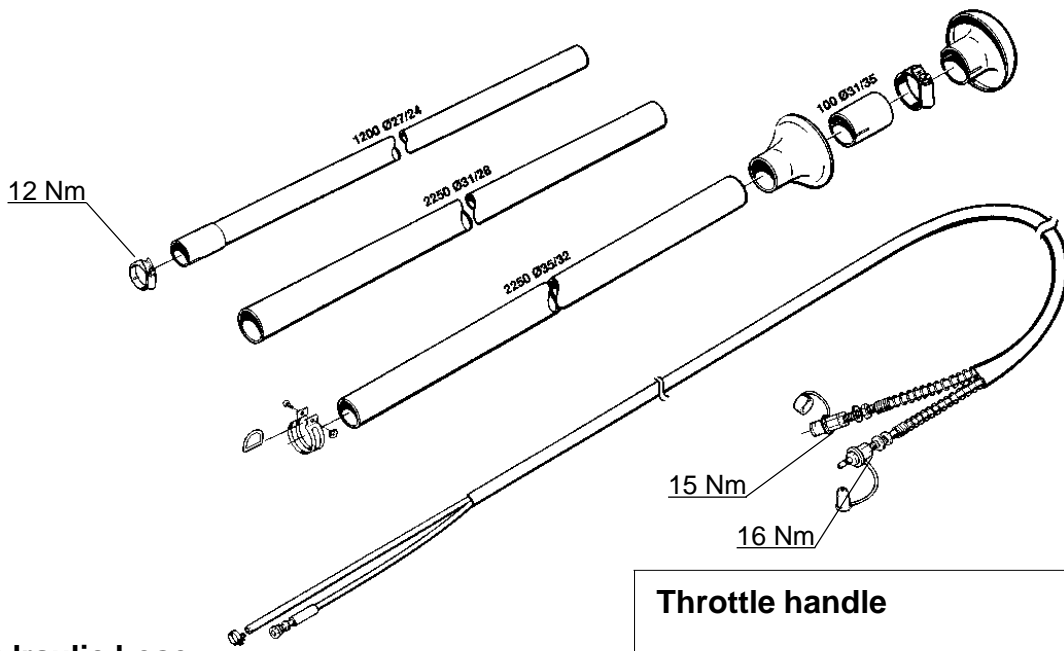

Shaft, hydraulic hose

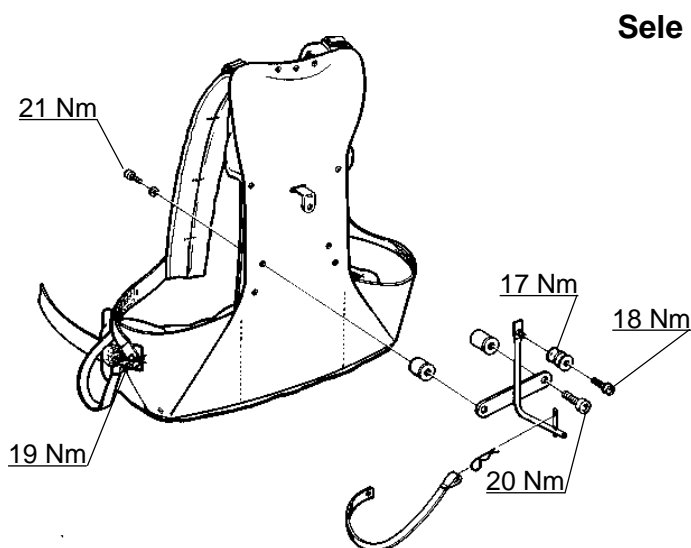

Sele

Throttle handle

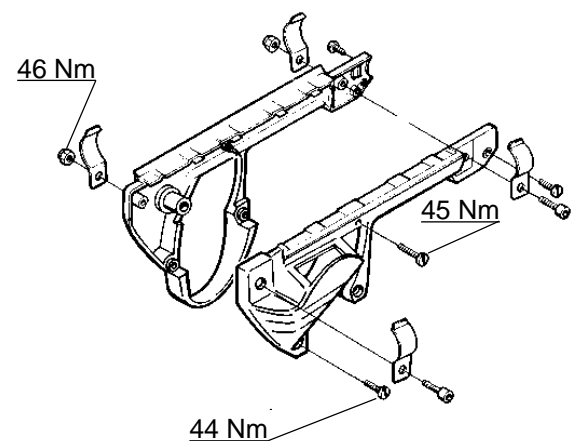

2. Starter unit

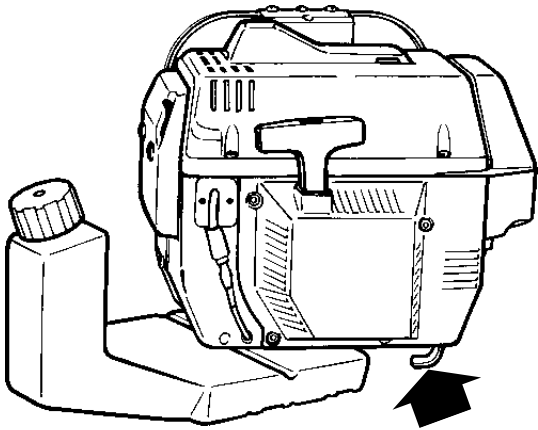

WARNING! If handled carelessly the return spring may spring out and cause injury. Always take care when you replace the starter cord or spring. Wear safety goggles!

Removal

Undo the four fuel tank clamps and move the fuel tank out of the way. Undo the cylinder cover. Unscrew the bolts that hold the starter unit against the crankcase and lift off the starter unit.

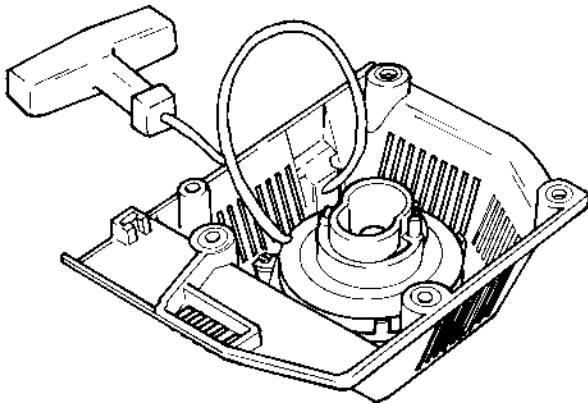

Release the spring by lifting up the cord and letting the pulley rotate clockwise. Undo the bolt at the centre of the pulley and the screws that hold the spring cassette.

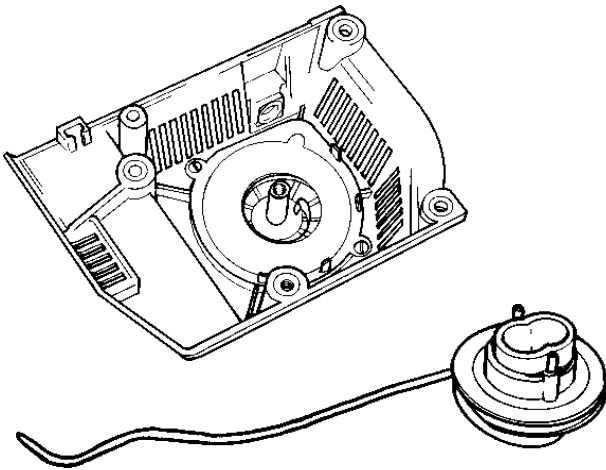

Carefully lift out the pulley and spring cassette. Clean them. Replace the cord and/or spring (with cassette) if necessary. Lubricate the return spring with light oil.

Assembly

Replace the spring cassette in the starter casing.

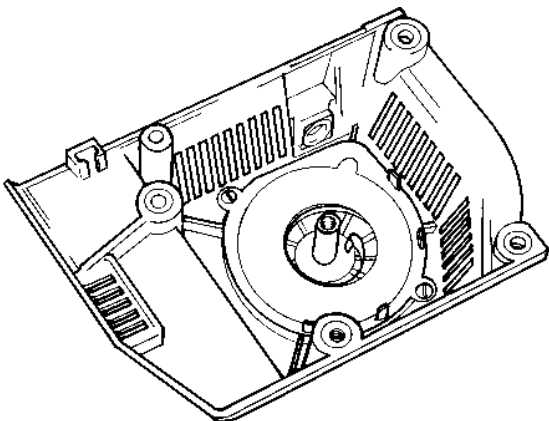

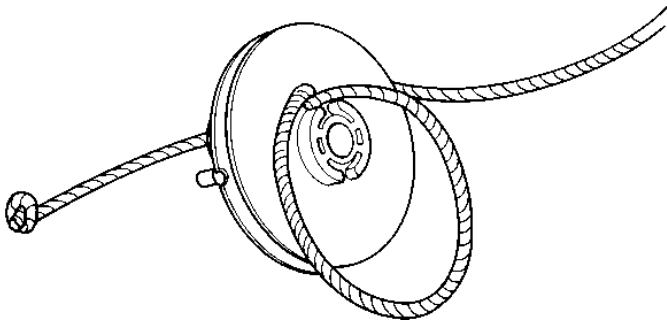

Thread in a new cord and attach it to the pulley. Wind about 4 turns of the cord around the pulley, anticlockwise. Fit the pulley above the spring cassette so that the end of the return spring engages in the pulley. Fit the bolt through the centre of the pulley.

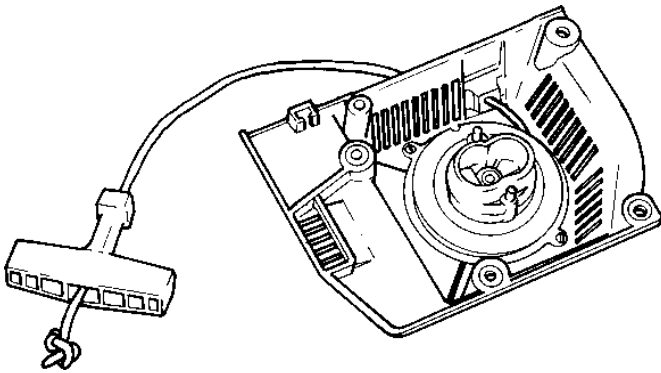

Thread the starter cord through the hole in the starter casing, then through the starter handle. Tie a good knot in the end of the cord.

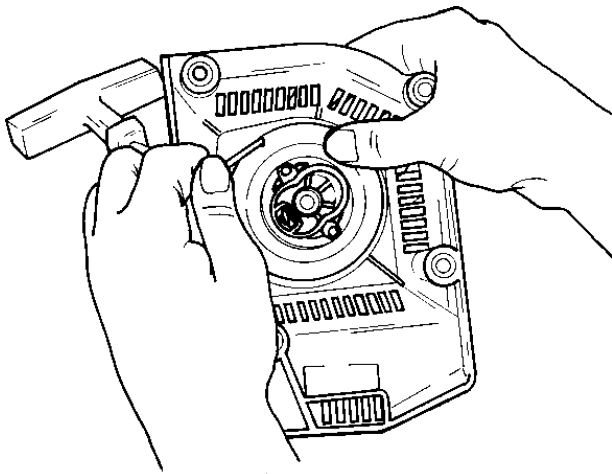

Run the cord through the cut-out in the pulley and wind the spring up a couple of turns. Make sure the pulley is free to rotate a further 1 1/2 turns when the cord is fully extended.

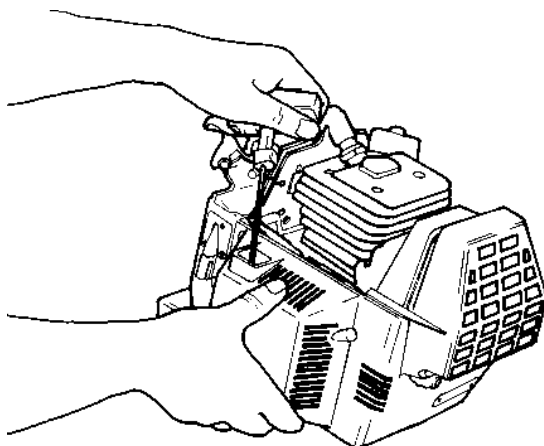

Refit the starter unit by first pulling out the starter cord and then placing the starter unit in position on the crankcase. Now release the starter cord slowly so that the starter lugs engage on the pulley. (Starter lugs, see page 26.) Tighten the bolts that hold the starter unit. Refit the cylinder cover and tank.

3. Fuel system

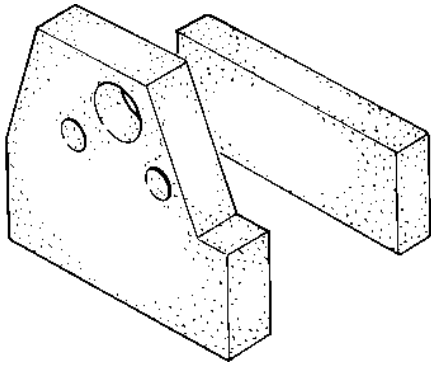

Cleaning the air filter

The air filter has two components. A low resistance pre-filter and the air filter itself. Regularly clean any dust or dirt from the air filter to prevent:

- Carburettor problems
- Starting problems
- Reduced performance
- Unnecessary wear to engine components
- Excessive fuel consumption

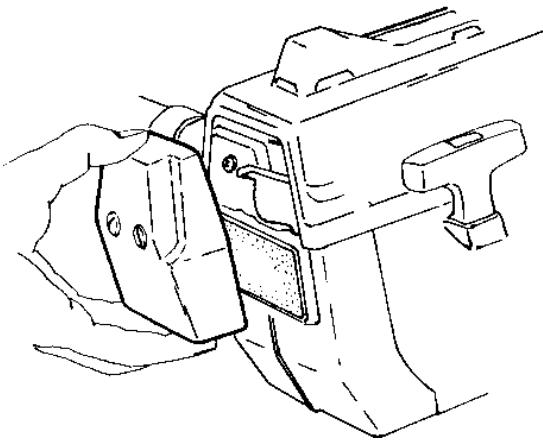

Remove the filter cover and take out the filter. Wash the filter in soapy water. Soak in filter oil 503 47 73-01 then squeeze out the excess. Always replace a damaged air filter.

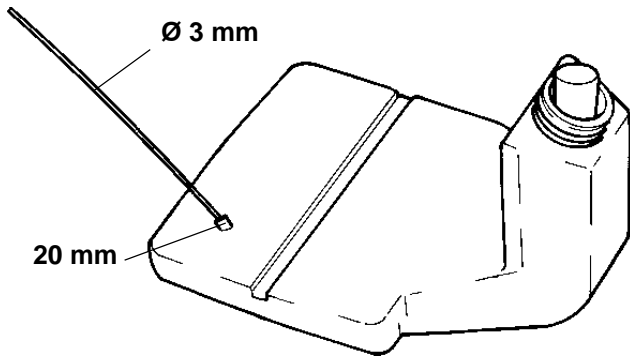

Replacing the fuel filter

Push the hose into the tank until only about 20 mm of the hose projects from the tank. Insert a 3 mm diameter steel cable into the hose. Pull the filter out of the filler hole using pliers.

NOTE! Make sure the hose does not fall into the tank. Replace the filter. Pull the hose back to its original position. Remove the cable.

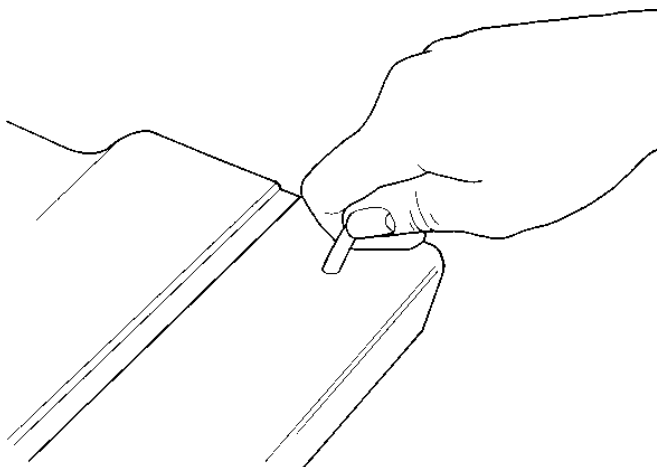

Replacing the fuel hose

Push the old hose into the tank. Pull the hose and filter out through the filler hole of the tank. Fit a new hose through the tank opening. Push the hose in until only about 20 mm projects from the tank. Insert a 3 mm diameter cable into the hose and out through the filler hole. Pull the end of the hose out of the filler hole using pliers. Fit the filter and pull the hose back to its original position. Remove the cable.

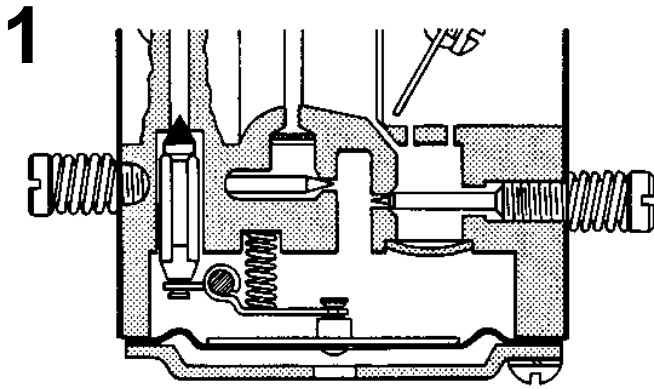

Carburettor

The carburettor is of the membrane type. It is divided into three units or main functions.

1. Metering unit

This includes the fuel jets and control mechanism.

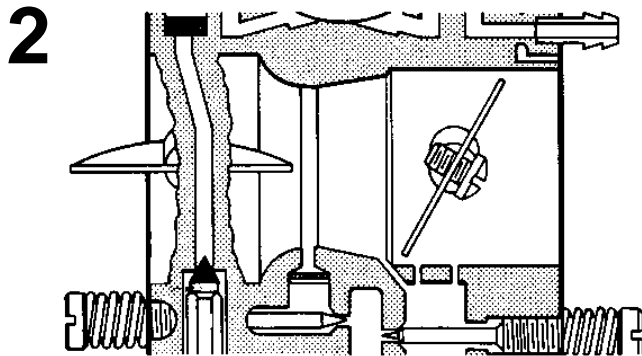

2. Mixture unit

This is where fuel and air are mixed in the venturi and includes the choke and throttle flap.

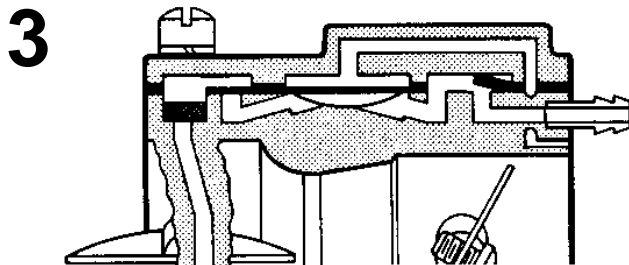

3. Pump unit

Here fuel is pumped from the tank to the metering unit.

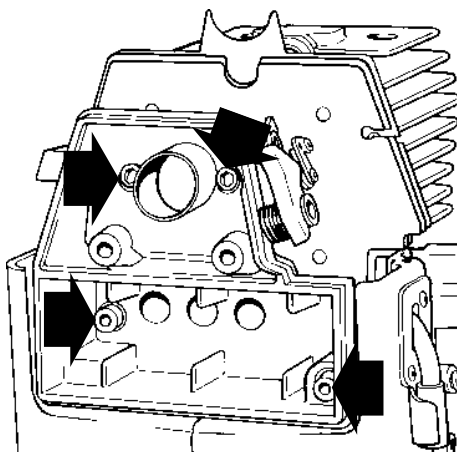

Removal

Remove the air filter, throttle cable and fuel hose.

Unscrew the 2 bolts from the air filter mounting, unscrew the carburettor bolts and remove the carburettor with air filter mounting and spacer. Clean all components.

3

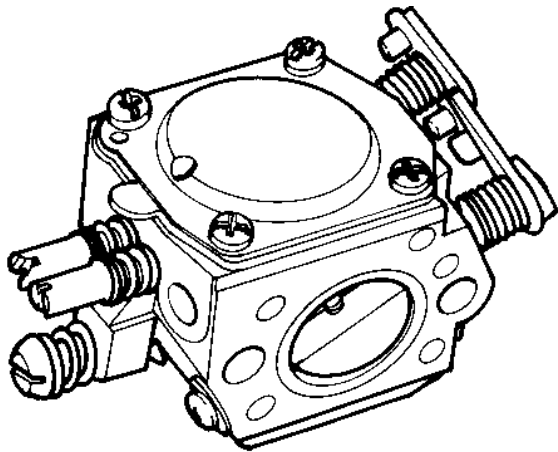

Remove the membrane cover and carefully lift off the control membrane.

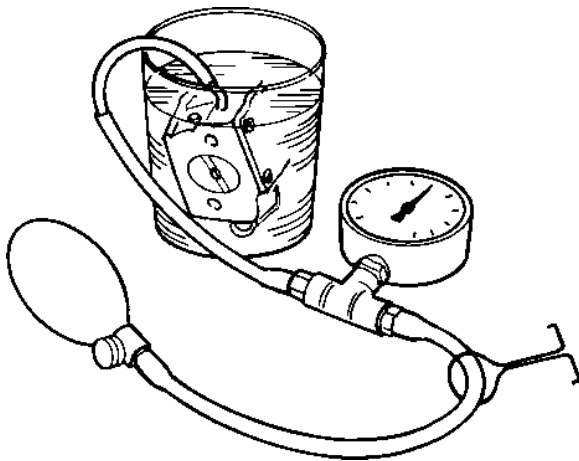

Connect the pressure tester to the fuel hose nipple. Lower the carburettor into a container filled with petrol. Pressure test to 0.4 bar (40 kPa). No leakage is permitted.

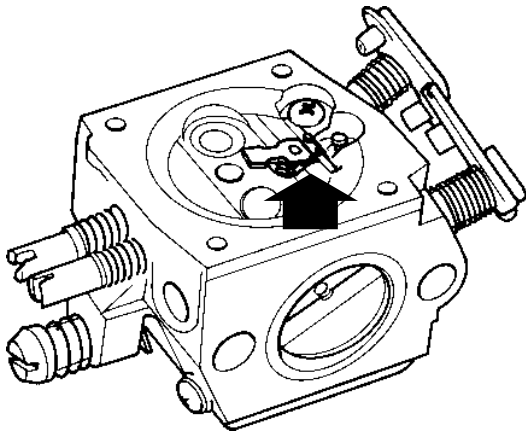

If there is a leak, remove the needle valve. Undo the screw and lift off the lever, spindle, needle valve and spring.

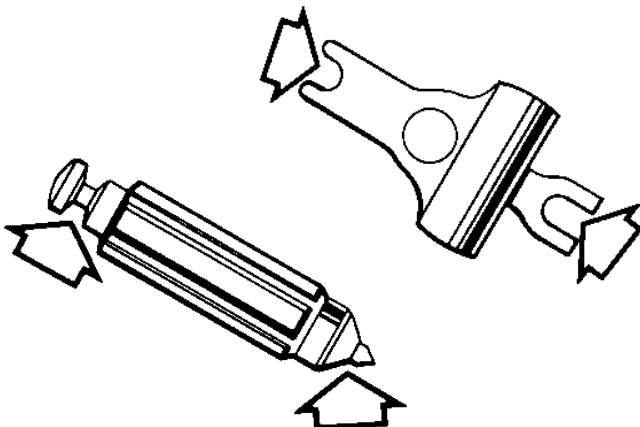

Examine the needle valve for wear. Replace the needle if worn or damaged. Examine the lever for wear. Replace the lever if worn or damaged.

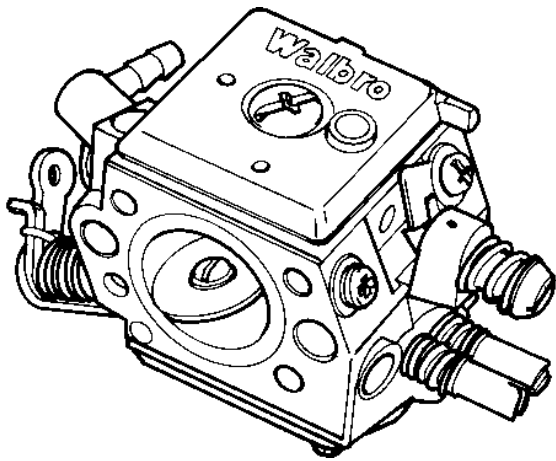

Remove the screw and lift the cover off the pump membrane

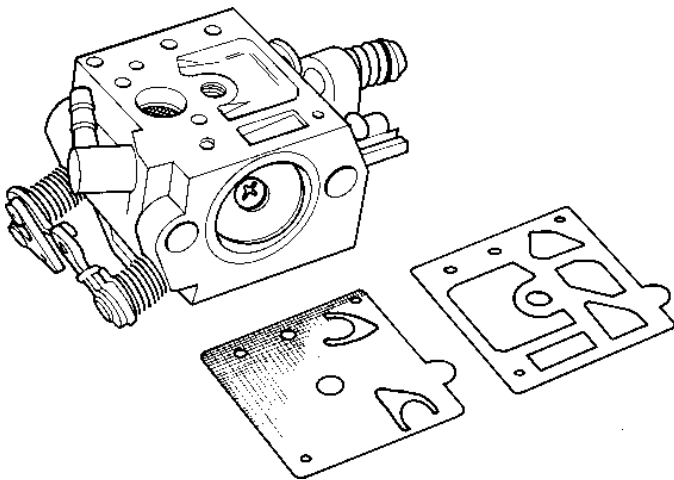

Lift off the gasket and pump membrane.

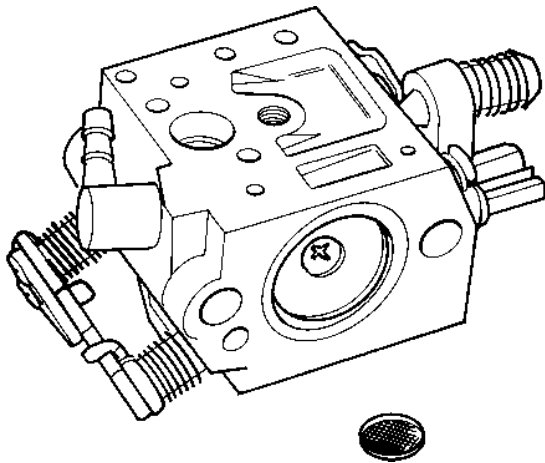

Carefully remove the fuel mesh using a needle, for example.

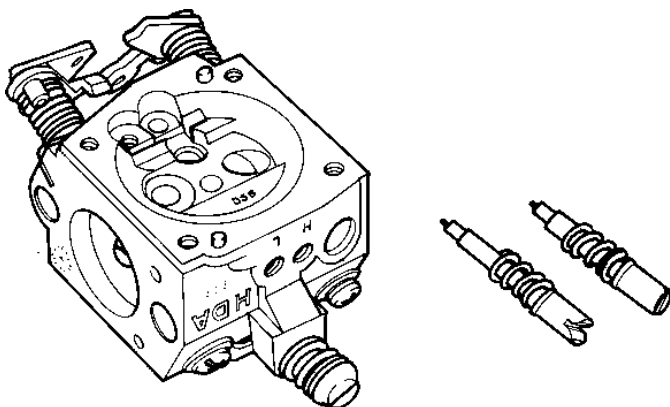

Unscrew the jet needles. (H=long, L=short). Clean all components.

3

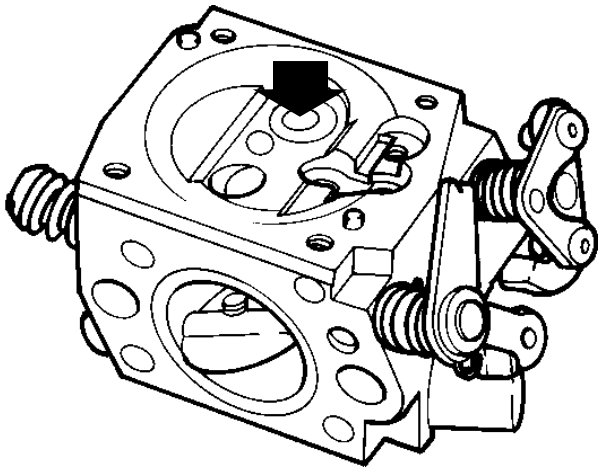

If the carburettor is very dirty the chamber under the blind plug must also be cleaned. Drill a small hole in the centre of the blind plug and carefully prise it out. Clean the carburettor housing and blow all channels clean using compressed air.

Assembly

Fit a new blind plug. Use a suitable mandrel to drive in the plug and give an airtight seal.

Inspect the throttle flaps and their spindles for wear. If they are worn it will be difficult to set the idle speed. Always replace the flap and spindle at the same time.

Make sure the flaps are fitted correctly.

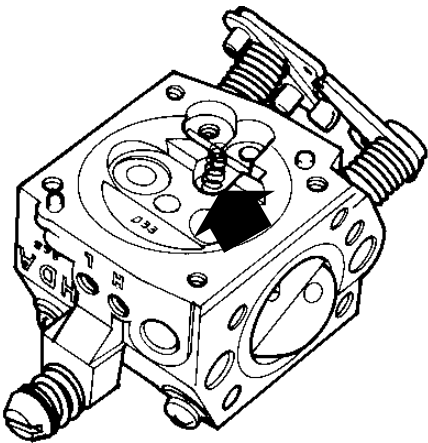
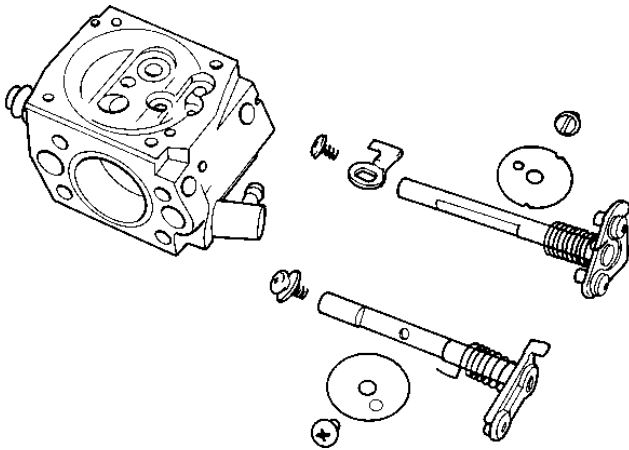

Fit the various components of the metering unit in the reverse order to removal.

NOTE! Make sure the lever springs are replaced the right way round

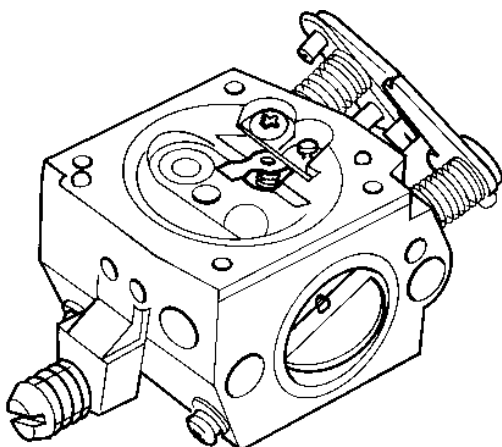

Check that the lever is level with the top of the carburettor. Adjust the lever if necessary.

If lever is too high = too much fuel.

If lever is too low = too little fuel.

Fit the cover.

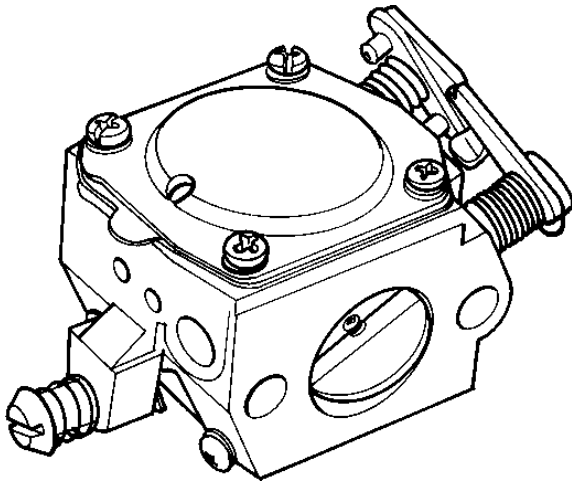

Fit the pump unit components. Replace the fuel mesh if it is damaged. Fit a new pump membrane and new gasket if necessary. Fit the H and L needles.

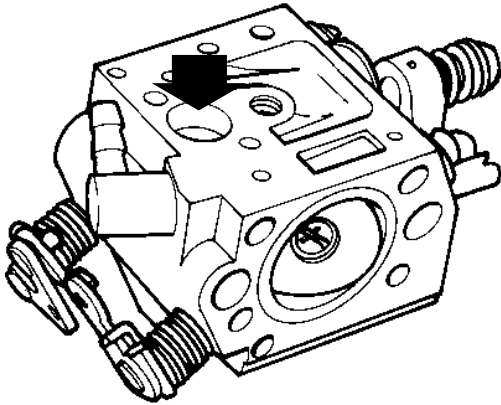

Check the angle of the fuel hose nipple if it was moved during servicing. Check that the carburettor is airtight. Pressure test to 0.4 bar (40 kPa.) No leakage is permitted.

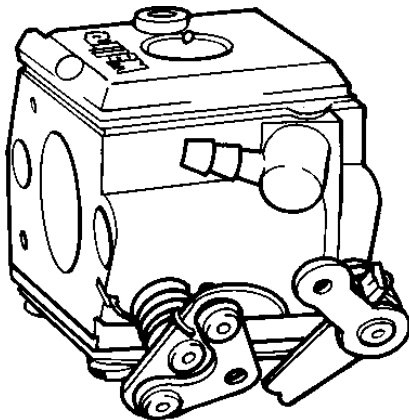

Check that the automatic choke levers are not worn and that they engage in each other.

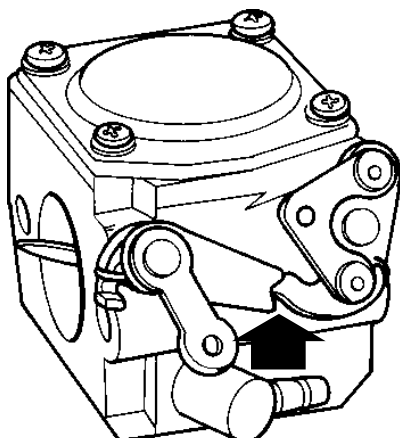

3

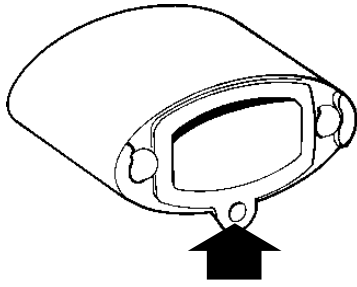

Check that the spacer is undamaged and that the pulse channel is not blocked.

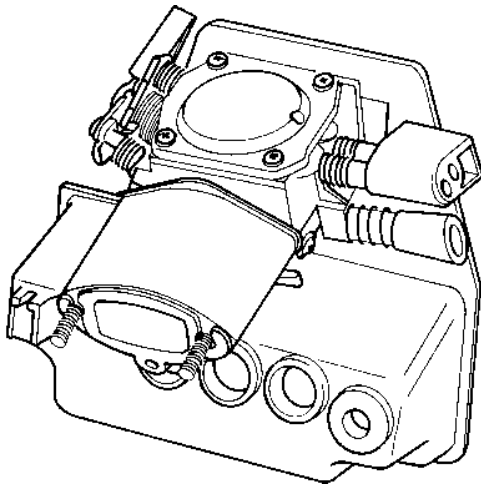

Fit the filter holder and carburettor bolts (with insulating sleeves) to the carburettor. Fit the gaskets and spacer.

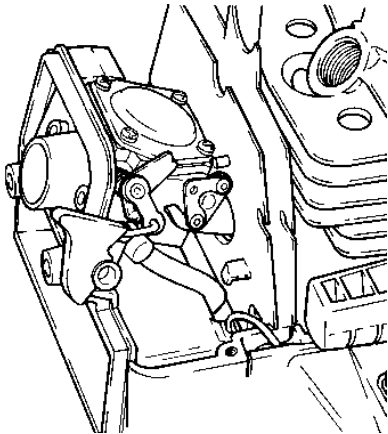

Insert the spacer through the baffle.

NOTE! Make sure the gasket between the cylinder and spacer is correctly positioned.

Screw the carburettor bolts in alternately. Do not tighten. Tighten the bolts for the air filter holder. Then tighten the carburettor bolts.

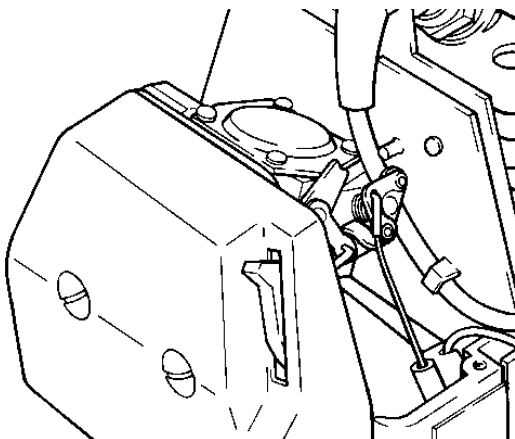

Connect the fuel hose and throttle cable.

Fit the choke/start control and check its operation. Fit the air filter and air filter cover.

Carburettor operation and adjustment



WARNING! Never start the pruning saw if the hydraulic oil tank and hoses are not fitted. If the hydraulic oil tank is not fitted the clutch may come loose and cause injury. If the hoses are not fitted the engine cannot be revved up and the hydraulic pump and clutch may be damaged.

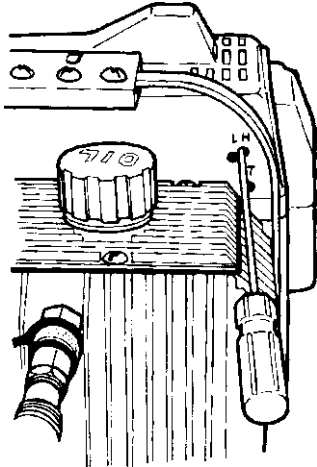

The carburettor controls engine speed via the throttle. Fuel is mixed with air in the carburettor. The L and H needles are used to adjust the amount of fuel that is mixed with air when the throttle is activated. If they are turned clockwise the fuel/air mixture is made richer (more fuel). The T screw controls the throttle setting at idle; turning it anticlockwise reduces the idle speed.



WARNING! Do not operate the pruning saw until it has been correctly adjusted or repaired.

When the carburettor is correctly adjusted the pruning saw should accelerate smoothly without hesitating and the engine will burble slightly at full throttle. This indicates that the pruning saw is working at maximum efficiency.

NOTE! The chain must not rotate at idle.

Before adjusting

NOTE! Before making any adjustment make sure the air filter is clean and that the hydraulic tank and hoses are connected.

Place the pruning saw on a flat surface and make sure the bar and chain are pointing away from you and cannot touch the surface or any other object.

Gently screw the L and H needles clockwise all the way in. Then unscrew both needles one turn. The carburettor setting is now H=1 and L=1. Start the pruning saw and let it run for ten minutes to warm up.

NOTE! If the chain rotates at idle, turn the T screw clockwise until it stops.

Basic setting

Gently screw the H and L needles all the way in. Then open H 1 1/4 turns and open L 1 turn. The basic setting can vary between H=1 to 1 1/4 turns and L=1 to 1 1/4 turns.

NOTE! If the chain rotates at idle, turn the T screw clockwise until it stops.

The basic setting is richer than the optimum setting and should be maintained for the first 3-4 hours the saw is used. The carburettor adjustment can then be fine tuned.

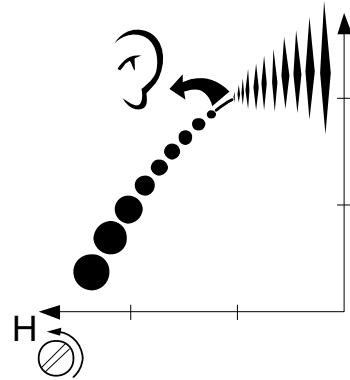
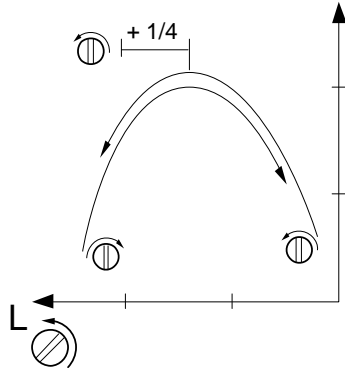

Fine tuning

First adjust the L needle, followed by the T needle, and finally the idle screw T. The recommended engine speeds are as follows:

Max. engine speed 11,000 rpm

Idle speed 2,500 rpm

Low speed needle L

Find the highest idle speed by slowly turning the low speed needle clockwise, then anticlockwise. When you have found the highest idle speed turn the L needle 1/4 turn anticlockwise.

NOTE! If the chain rotates at idle, turn the T screw clockwise until it stops.

High speed needle H

The high speed needle affects the power and engine speed of the pruning saw.

Run the pruning saw at full throttle for about 10 seconds.

Then turn the H needle 1/4 turn anticlockwise.

Run the pruning saw at full throttle again for about 10 seconds and listen for any difference in speed.

Repeat this procedure after turning the H needle a further 1/4 turn anticlockwise. You have now run the pruning saw at H=1, H=1 1/4 and H=1. At full throttle the engine should sound different at each setting.

The H needle is correctly set when the engine "bubbles" slightly. If smoke comes from the silencer and the engine bubbles too much then the mixture is too rich. If the pruning saw "screams" then the setting is too weak. Turn the H needle clockwise until the engine sounds right. Do not exceed the recommended engine speed of 11,000 rpm.

Fine tuning the idle setting T

If it is necessary to adjust the idle setting, turn the idle screw T clockwise with the engine running until the chain starts to rotate. Then turn the idle screw anticlockwise until the chain stops. The idle setting is correct (around 2,500 rpm) when the engine runs smoothly in all positions and there is a good margin to the speed at which the chain starts turning.

Trouble shooting chart

	<i>Dirt in channels</i>	<i>Loose blind plug</i>	<i>Dirt in screen</i>	<i>Worn metering components</i>	<i>Lever set too high</i>	<i>Lever worn</i>	<i>Leakage from pump section</i>	<i>Fuel mesh blocked</i>	<i>Leakage from spacer, gasket</i>	<i>Air filter blocked</i>	<i>Fuel filter blocked</i>	<i>Hole in fuel hose</i>	<i>Fuel hose loose or damaged</i>	<i>Dirt in fuel hose</i>	<i>Adjuster needles bent or broken</i>	<i>Needle seats damaged</i>	<i>Worn choke spindle, flap</i>
Difficulty starting									•	•			•				•
Fuel drips from carburettor				•								•					
No idle		•								•		•	•				
Idles irregularly				•	•							•	•				
Idle setting too rich				•	•	•			•								
Acceleration poor (needs choke)	•		•					•		•	•						
Engine fades								•		•	•						
Not getting fuel						•			•								
Difficult to adjust		•												•	•		
Needle setting out of range	•	•	•						•								

4. Throttle lock

Removal

Undo the six screws that hold the handle together.

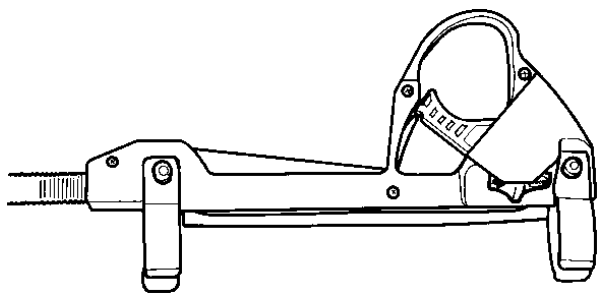

Open up the handle. Remove the throttle lock and check the spring underneath it.

Assembly

Secure the spring under the throttle lock and lay the cable and leads as shown in the diagram. Assemble the two halves of the handle and tighten the 6 screws.

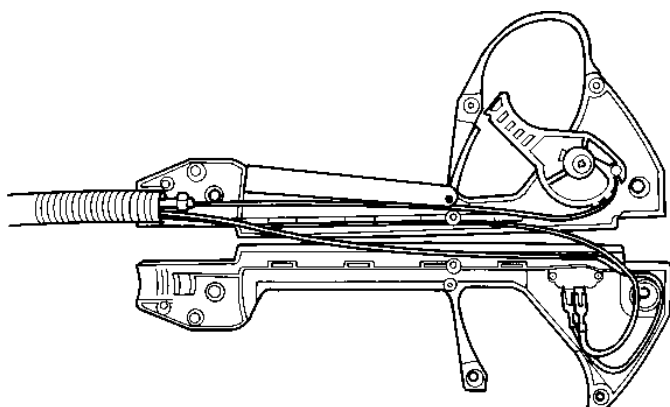

Replacing the throttle cable

Take the handle apart and disconnect the throttle cable. Disconnect the throttle cable from the carburettor and pull it out through the sleeve.

Thread a new cable through the sleeve, connect it to the carburettor and the handle. Refit the throttle lock and spring. Reassemble the halves of the handle and tighten the screws.

5. Ignition system

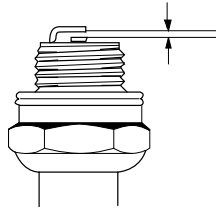

Checking the spark

Remove the spark plug and clean off any carbon deposits. Check the electrode gap. It should be 0.5 mm. If the electrodes are worn you should replace the spark plug.

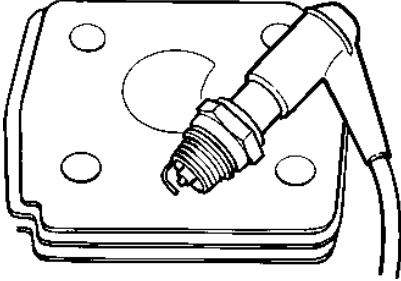

Trouble shooting

Set the stop switch to the stop position. Earth the spark plug cable against the cylinder and pull sharply on the starter handle. A spark should jump between the electrodes.

If there is no spark

Repeat with a new spark plug or test with test plug no. 502 71 13-01.

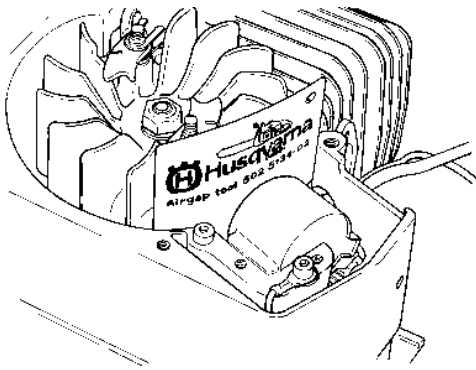

- If there is still no spark, disconnect the short circuit lead from the stop switch. (See page 24.) Pull the starter. If a spark appears now then the fault lies in the stop switch. Replace the switch.
- If there is still no spark check the spark plug cap, cables and connections for poor contact (dirt), a break in the circuit or damaged insulation.
- Using a feeler gauge 502 51 34-02 check that the air gap between the ignition module and the flywheel magnets is 0.3 mm. Adjust if necessary. Loosen the screws on the ignition module. Position the feeler gauge and push the ignition module towards the flywheel. Tighten the screws and check the air gap once again. If there is still no spark then you must replace the ignition system.

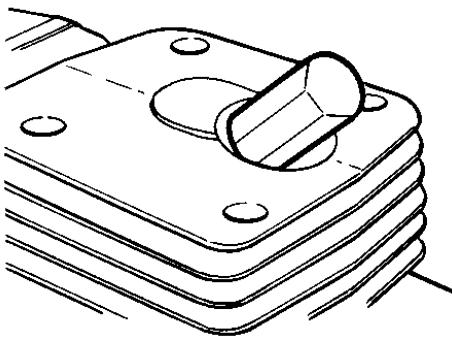

Removal

Disconnect the ignition cable from the spark plug. Remove the baffle, the screws that hold the ignition module and the lead from the stop switch. Fit the piston plug in the spark plug hole. NOTE! Use the full thread length.

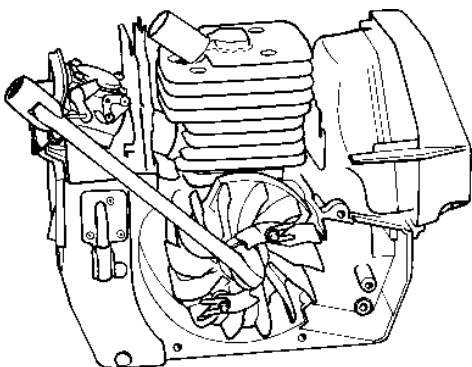

Unscrew the flywheel nut anticlockwise and remove it and the washer.

5

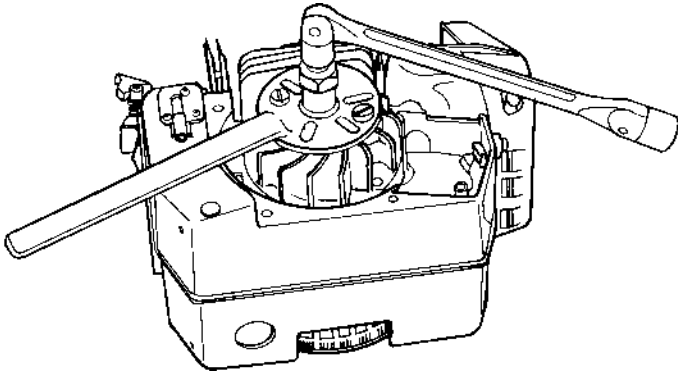

Unscrew the piston stop. Fit the key over the flywheel using the two M5 bolts. Centre the key, tighten the M5 bolts and screw in the puller. Remove the flywheel.

Assembly

Remove the key from the flywheel. Check that the starter lugs move freely, that they are not worn or damaged and that the return springs provide the required tension. Replace if necessary.

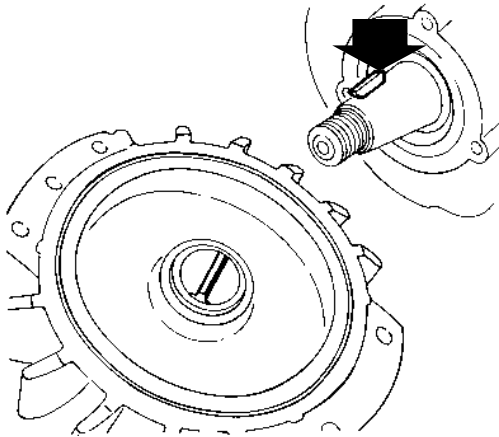
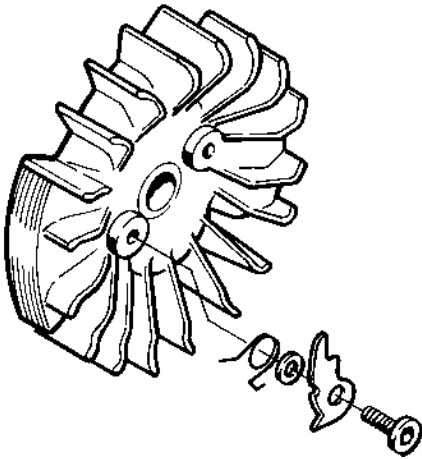

Place the key in the slot in the crankshaft. Line up the slot in the flywheel with the key.

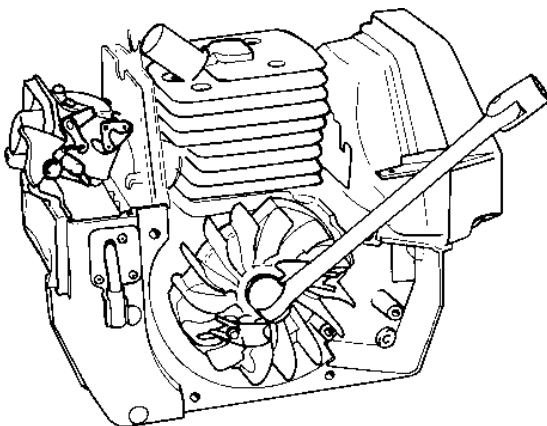

Screw the piston plug into the cylinder. Place the washer and nut on the flywheel. Tighten the nut (clockwise). Bolt torque: 24-29 Nm. Remove the piston stop.

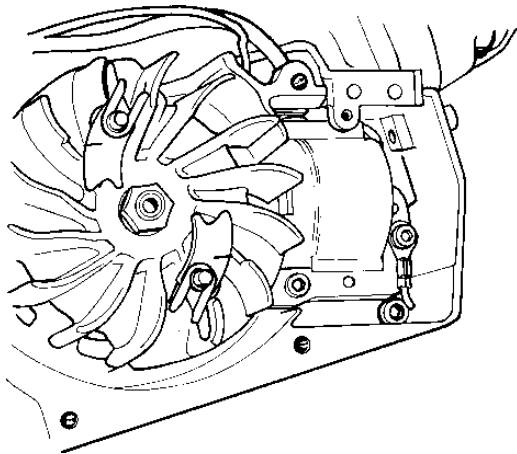

Connect the short circuit lead to the ignition module and fit the module on the crankcase without tightening the screws. Place the feeler gauge between the module and the flywheel magnets. Push the module against the flywheel and tighten the screws.

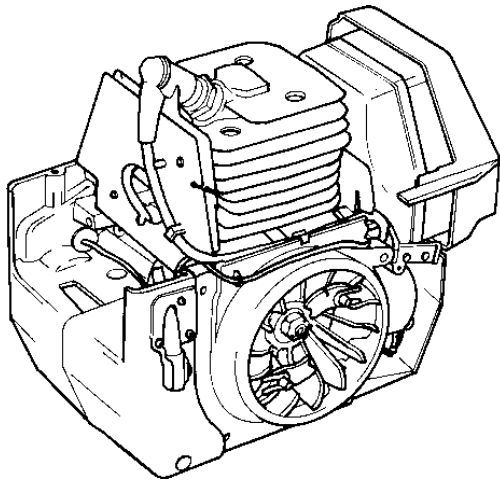

Fit the air baffle. Make sure the leads are routed correctly and cannot become trapped. Fit the starter unit.

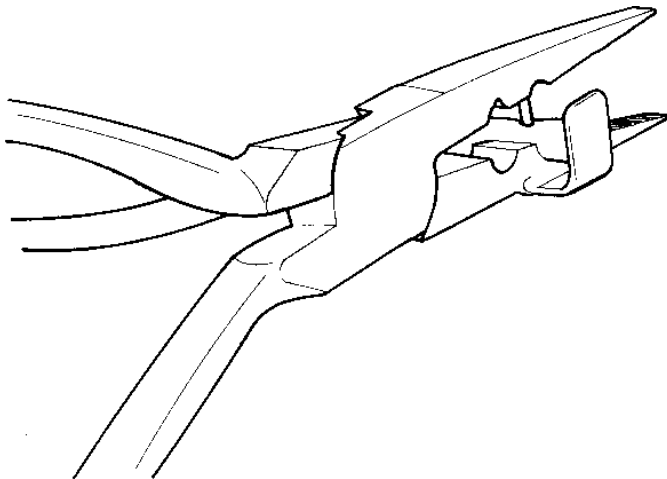

Fitting the spark plug cap

Make a hole in the ignition lead using pliers 502 50 06-01.

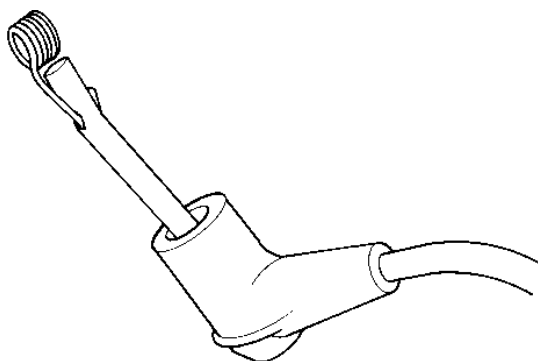

Push the ignition lead through the spark plug cap and fit the connector spring using the tongs. Slide the cap back over the connector spring.

6. Clutch



WARNING! Never start the pruning saw if the hydraulic oil tank and hoses are not fitted. Otherwise the clutch may come loose and cause injury.

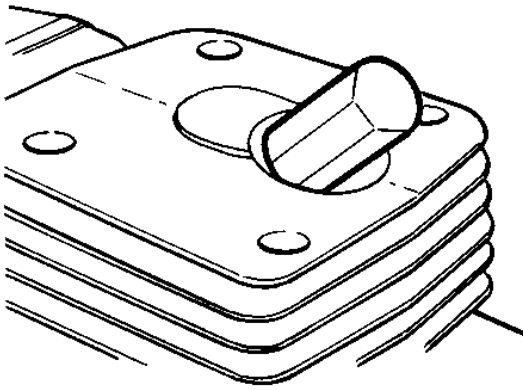

Removal

Fit the piston plug in the spark plug hole. Use the full thread length!

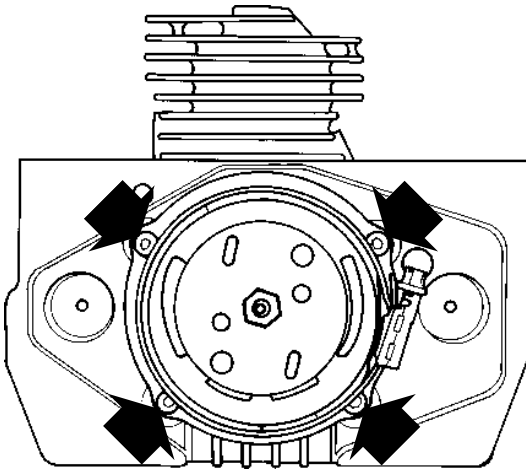

Unscrew the 4 engine adapter bolts.

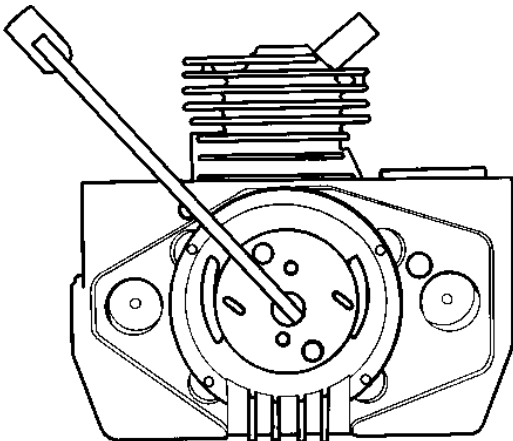

Unscrew the centre nut anticlockwise. Remove the clutch. The complete clutch assembly should be replaced to prevent imbalance.

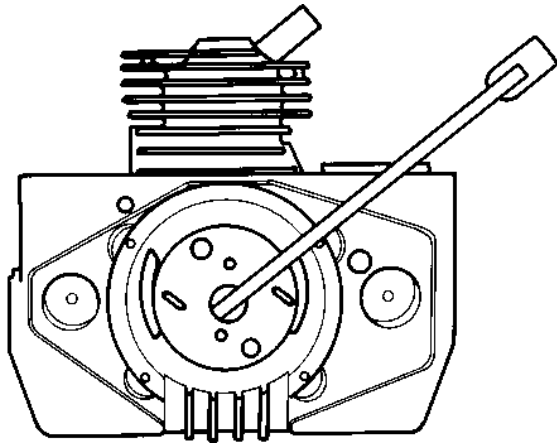

Assembly

Fit the clutch in place and tighten the nut (clockwise).

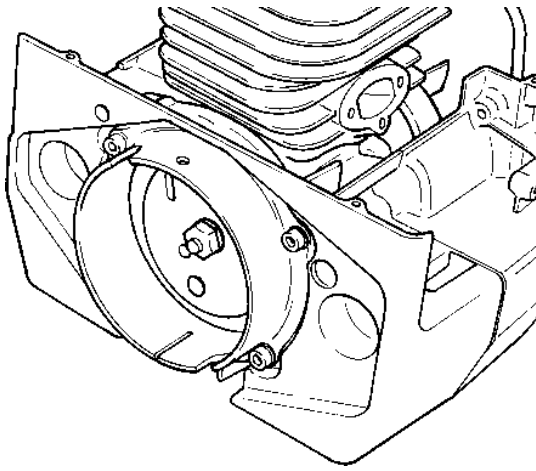

Fit the engine adapter with the hole on top and the slot at the bottom.

7. Cylinder and piston

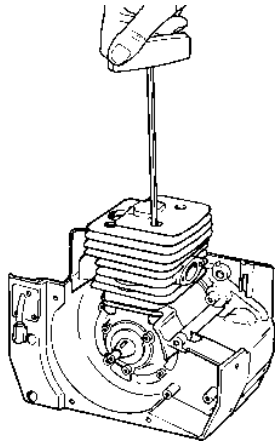

Removal

Remove the cylinder cover. Remove the air filter, carburettor assembly, silencer cover, silencer and spark plug.

Undo the cylinder bolts in diagonal sequence and lift off the cylinder. Clean any carbon deposits from the cylinder.

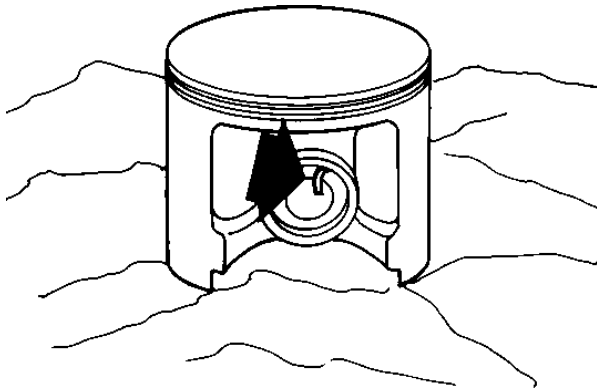

Cover the crankcase opening with a rag and clean any carbon deposits from the top of the piston. Remove the locking rings and push the gudgeon pin out of the needle bearing.

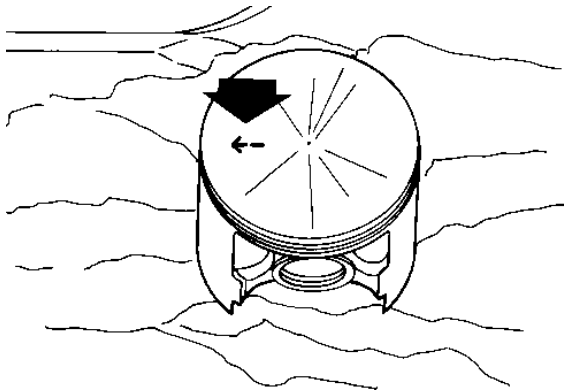

Assembly

NOTE! Replace old gaskets. Lubricate the gudgeon pin needle bearing with a few drops of oil.

Make sure the arrow on top of the piston points towards the exhaust side.

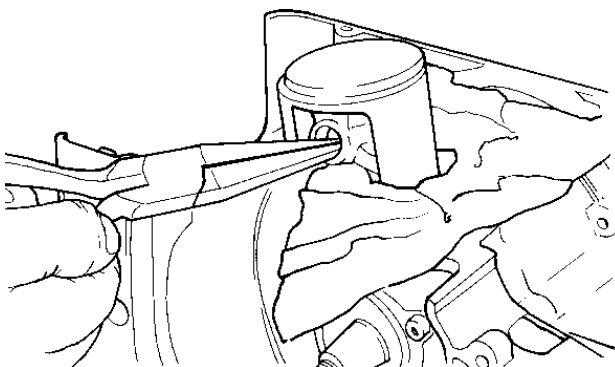

Push in the gudgeon pin and fit the locking rings using pliers.

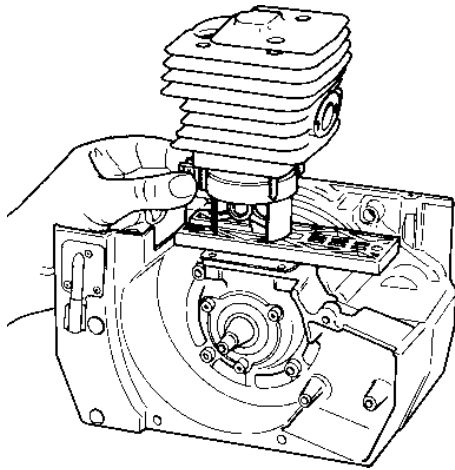

Fit the cylinder with the aid of assembly kit 502 50 70-01 making sure that the opening in the piston ring is in line with the guide pin. Do not forget the cylinder base gasket. Tighten the cylinder bolts in diagonal sequence.

Fit the silencer and silencer cover. Bolt the carburettor in place. Fit the fuel hose, short circuit lead, spark plug and spark plug cable. Refit the air filter followed by the cylinder cover.

Defect

Broken cooling fins, damaged threads or broken bolt near exhaust port.

Signs of seizing in cylinder barrel (especially near exhaust port).

Surface coating in cylinder barrel worn through (especially near top of cylinder).

Piston shows signs of seizing.

Piston ring seized in slot.

Remedy

If severe - replace cylinder. Repair thread with Heli-Coil.

Polish the damaged area with fine emery cloth to remove seized particles of aluminium. If gouging is excessive the cylinder and piston must be replaced.

Replace cylinder and piston.

Polish the damaged area carefully using a fine file or emery cloth. Polish the cylinder as described above. If gouging is excessive the cylinder and piston must be replaced.

Remove the piston ring carefully and clean the slot thoroughly before refitting. Check piston ring wear by inserting it into the bottom of the cylinder. The gap between the ends of the piston ring must not exceed 0.6 mm.

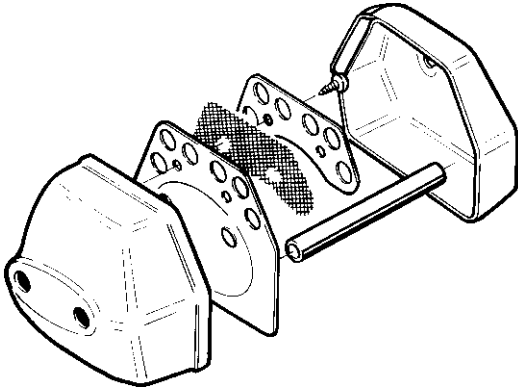

Silencer

It is a legal requirement in some countries that the silencer is fitted with a spark arrester mesh. Check the mesh, clean or replace it if it is damaged. If a spark arrester mesh is not required by law then a silencer without spark arrester mesh should be used.

NOTE! A blocked spark arrester mesh can cause overheating and result in damage to the cylinder.

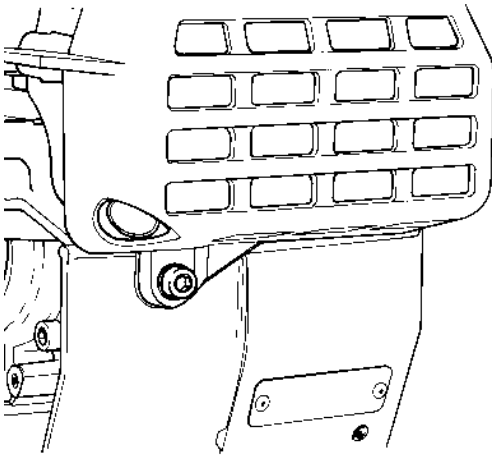

Removal

Remove the cylinder cover. Unbolt the silencer cover.

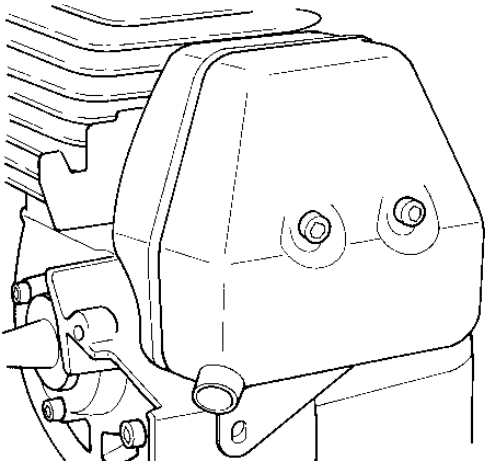

Undo the two silencer bolts and remove the silencer. Open up the silencer and clean it. Refit in the reverse order to removal.

8. Crankcase and crankshaft

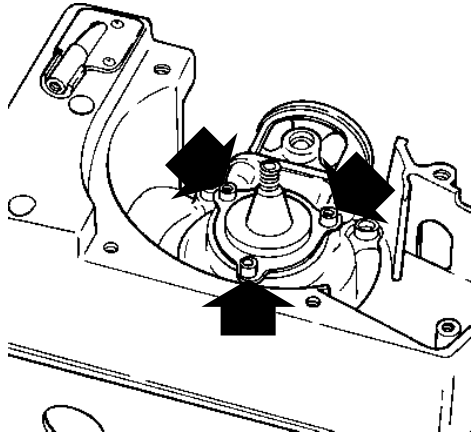

Replacing sealing rings

Magnet side

Remove the cylinder cover, air filter, starter unit and baffle. Remove the flywheel. (See pages 25-26.)

Undo the 3 bolts that hold the housing onto the crankcase.

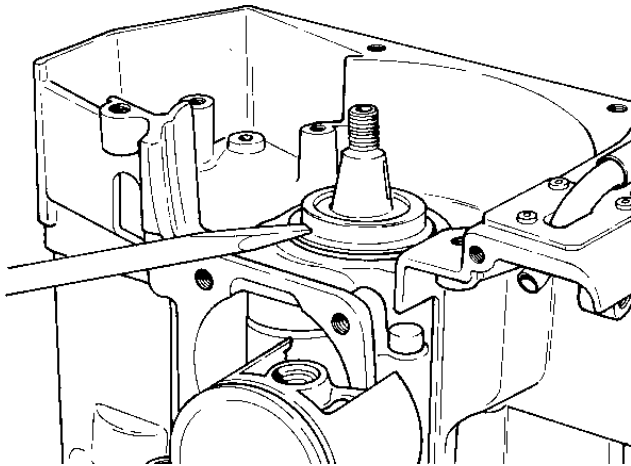

Prise off the sealing ring housing using a screwdriver or the like.

Press the new sealing ring into place with a suitable mandrel.

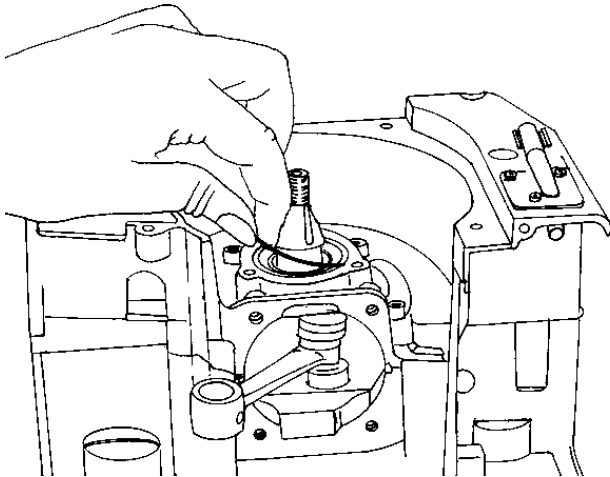

Always fit a new O ring under the housing.

Refit the sealing ring housing.

NOTE! Smear the 3 bolts that secure the housing with Loctite or a similar locking agent.

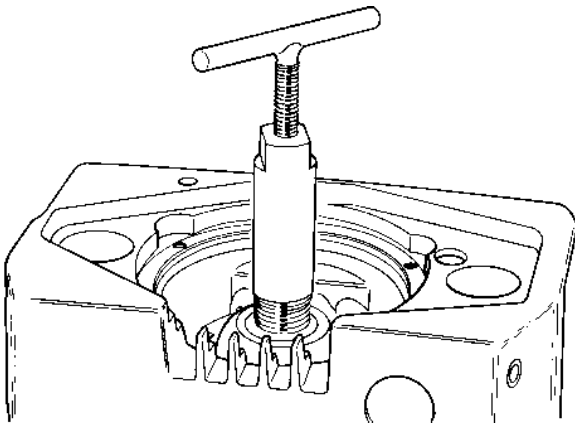

Drive side

Remove the clutch. Remove the sealing ring using tool 502 50 78-01. Use a suitable mandrel to fit the new sealing ring. The sealing ring must be flush with the surface of the crankcase.

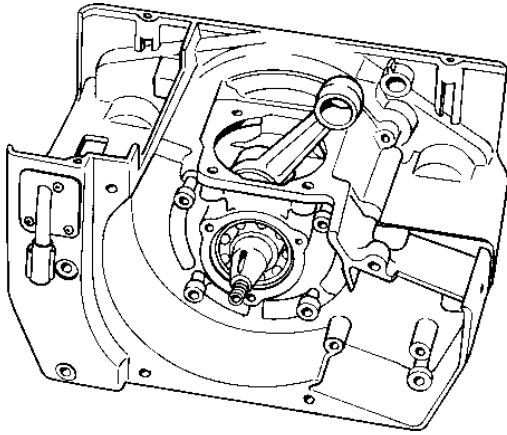

Opening the crankcase

Remove the ignition system, clutch, cylinder assembly, piston and cylinder base gasket.

Undo the seven crankcase bolts, unscrewing them a short distance at a time.

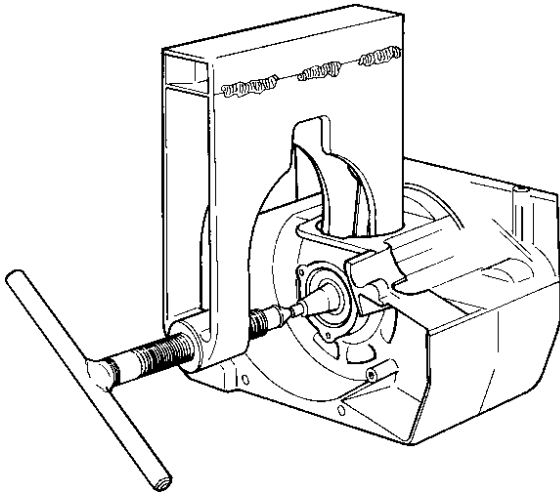

Fit tool 502 51 61-01 and separate the two crankcase halves.

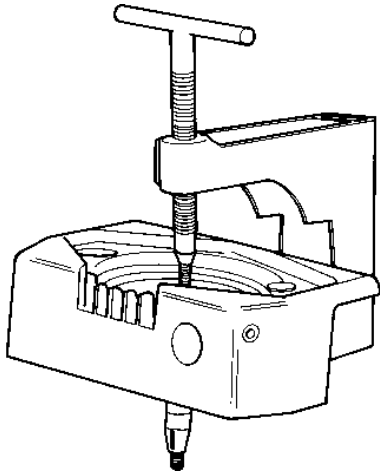

Use the same tool to press the crankshaft out of the crankcase.

Drive the sealing ring out of the drive side of the crankcase using a mandrel and remove the bearings by applying heat.

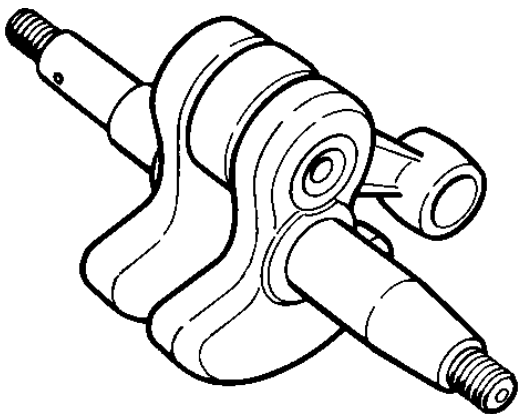

Checking the crankshaft

The crankshaft cannot be repaired and must be replaced if it is defective or damaged. On some crankshafts there may be a slight blue discoloration around the crank-pin. This is entirely normal and is due to a heat treatment applied around the crank-pin hole.

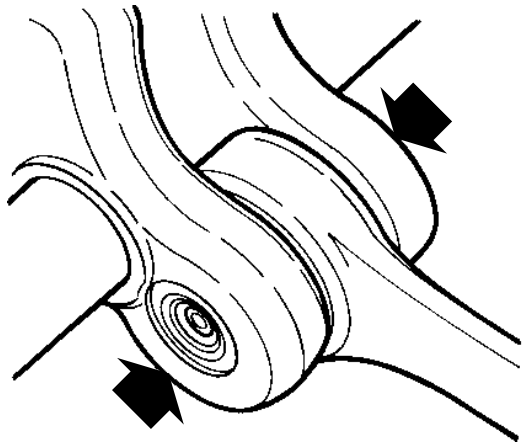

Check the big end of the piston rod. Replace the crankshaft if there are signs of seizing or discoloration on the sides.

The piston rod should not show any noticeable radial play (up and down movement) although sideways play is acceptable.

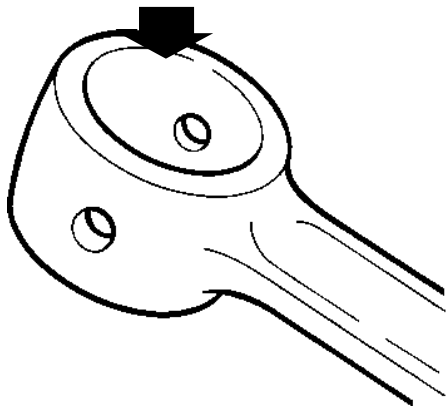

Check the small end of the piston rod. Replace the crankshaft if there are signs of seizing or discoloration on the bearing surface.

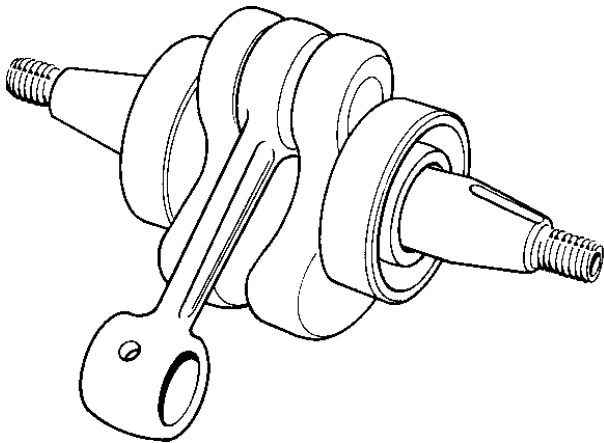

Assembly

Clean all components before assembly. Fit the casing bearings onto the crankshaft.

NOTE! It is important that the bearings are drawn tight up against the crankshaft.

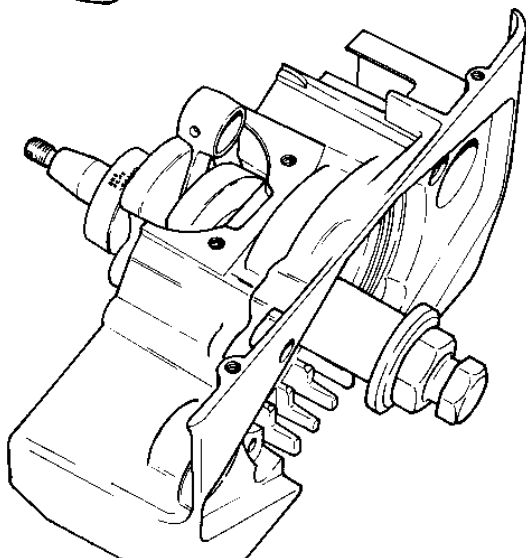

Heat the drive side of the crankcase and pull in the crankshaft using fitting tool 502 50 30-12.

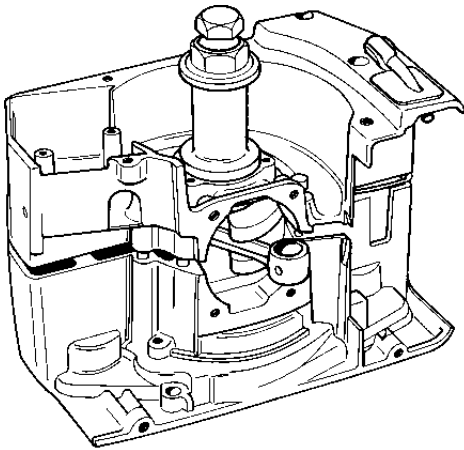

Heat the magnet side of the crankcase.
Grease and fit a new crankcase gasket. Place it on the drive side of the crankcase, line up the gasket with the bolts and pull the two crankcase halves together using the fitting tool.

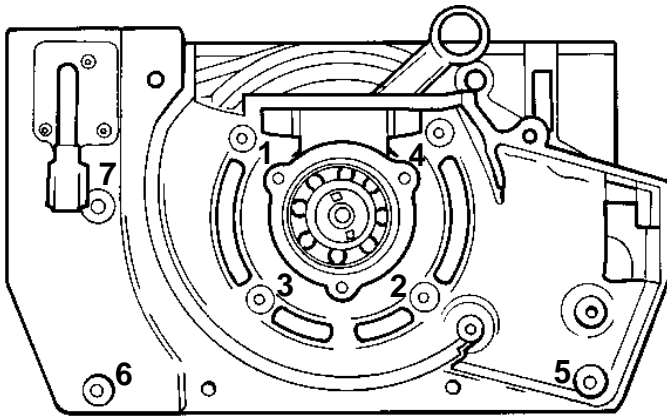

The crankcase bolts are of different length and should be fitted as follows:
1-5 l=30 mm
6-7 l=60 mm
Tighten all the bolts, starting with the ones closest to the crankshaft.

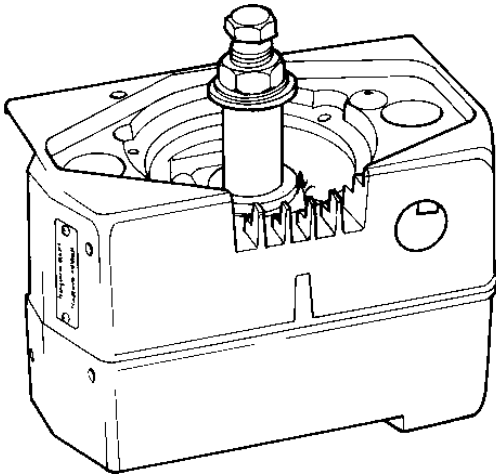

Fit the drive side sealing ring using the sleeve on the fitting tool (no. 502 50 30-12). The sealing ring must be flush with the crankcase surface.

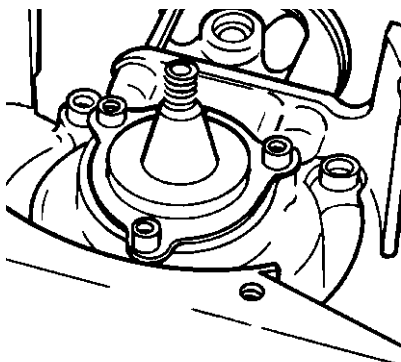

Always fit a new, greased O ring. Smear the 3 housing bolts with Loctite. Then tighten.

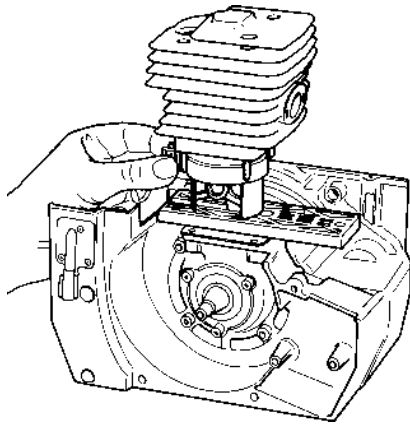

Fit the piston (arrow points towards exhaust port) and the cylinder assembly. Use a new cylinder base gasket.

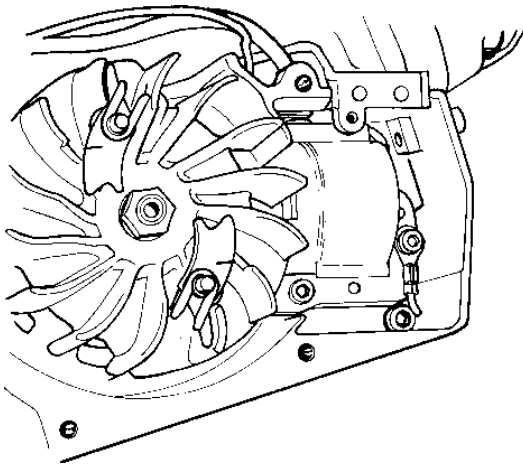

Fit the ignition system. Smear the bolts with Loctite. Fit the starter unit.

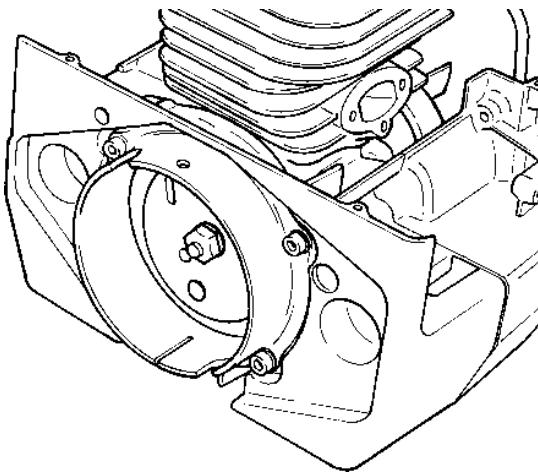

Fit the clutch and engine adapter.

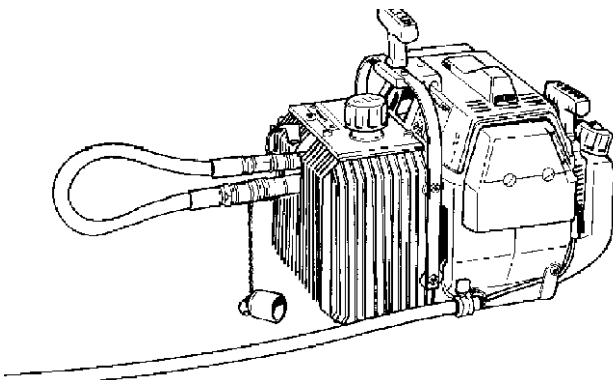

Fit the carburettor fuel hose, short circuit lead, choke control and air filter.

Fit the cylinder cover, hydraulic oil tank and shaft or test hose before testing.

9. Hydraulics



WARNING! Whenever you handle hydraulic components take care to ensure that no dirt enters the system. Dirt will cause operating problems in the hydraulic system.

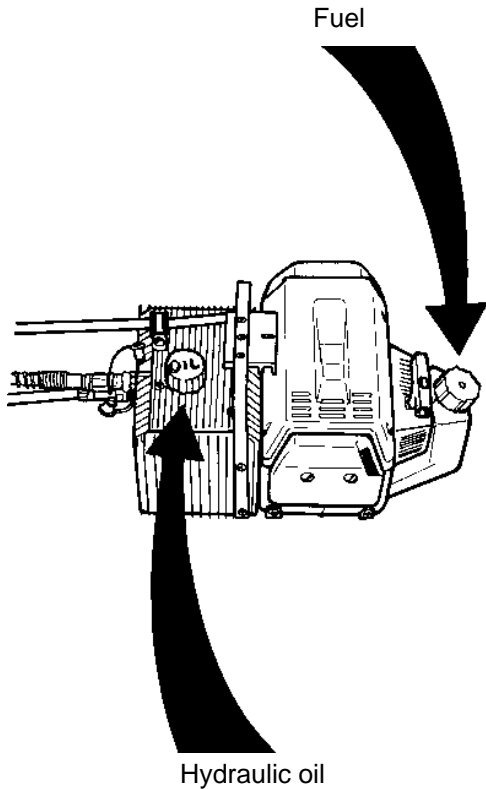

Recommended hydraulic oil

Hydraulic oil such as ISO grade Shell Tellus T32 is recommended if the air temp. is below +20°C. Hydraulic oil such as ISO grade Shell Tellus T45 is recommended if the air temp. is above +20°C. If the pruning saw is used in winter and/or in temperatures below -10°C then a lower viscosity oil should be used. Contact your hydraulic oil supplier.

The saw can also be used with a vegetable based or synthetic hydraulic oil of an equivalent grade.

NOTE! The flame point of the oil must exceed +160°C. The oil should also be non-conductive.

Fill with hydraulic oil so that the level is between the min and max marks on the dipstick.

If the hydraulic tank is new and unused it should be completely filled so that there is enough oil to fill the hoses. Top up with hydraulic oil after the machine has been run for the first 2-3 minutes. Check the level of the hydraulic oil each time you refuel.

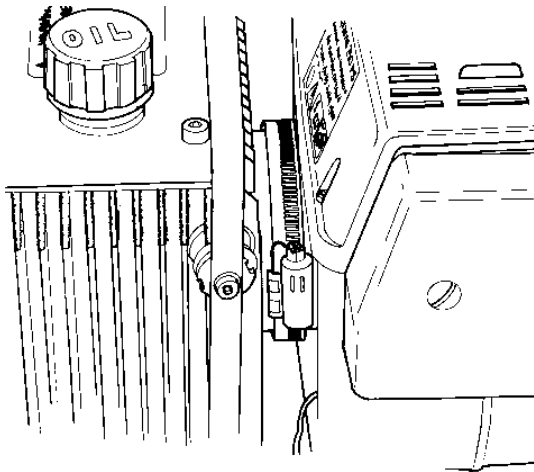

Hydraulic oil tank

Separate the hydraulic oil tank from the engine by undoing the jubilee clip and pulling the hydraulic tank away.

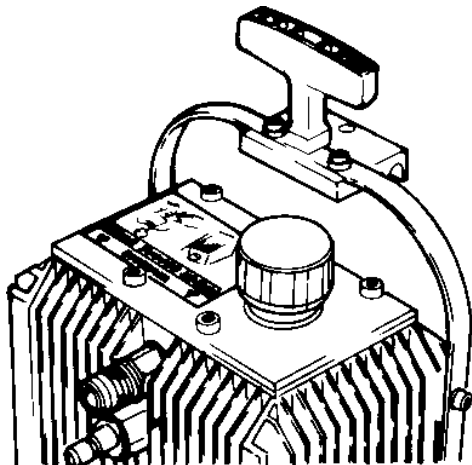

Undo the four bolts on the cover of the hydraulic oil tank and lift off the cover. Empty the oil.

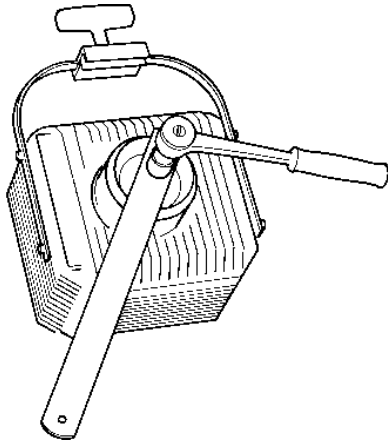

Use tool no. 502 52 16-01 and tool no. 502 52 13-01 (with square socket) to remove the clutch drum.
NOTE! Turn the Allen key clockwise!

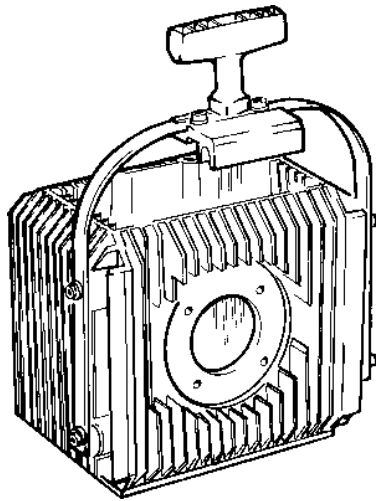

Undo all 8 bolts and remove the tank adapter.
Make sure the rubber sleeve is undamaged and makes a good seal. If not, replace the rubber sleeve.

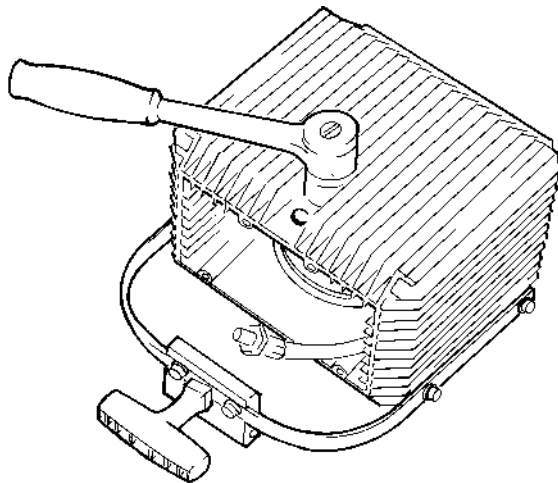

Disconnect the quick coupling at the top and pull the hydraulic hose out of the tank wall.

Disconnect the quick coupling at the bottom (17 socket) and remove the diffuser from the tank.

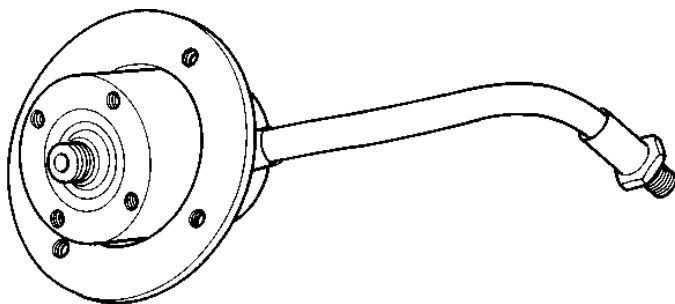

Now remove the hydraulic pump and support ring.

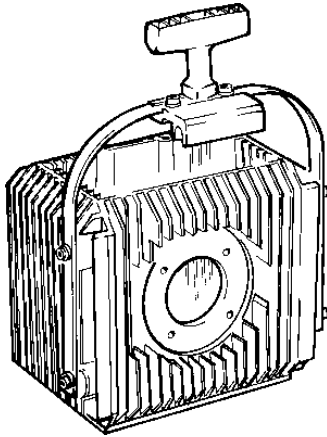

Assembly

Fit the rubber sleeve in the opening.

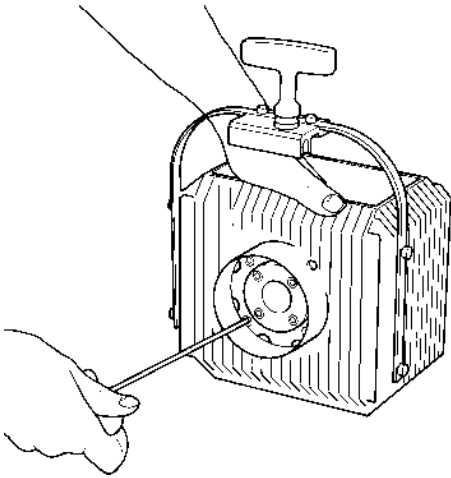

Hold the knurled side of the support ring against the rubber sleeve on the inside of the tank and bolt the tank adapter in place. Make sure the locating studs on the adapter are correctly positioned.

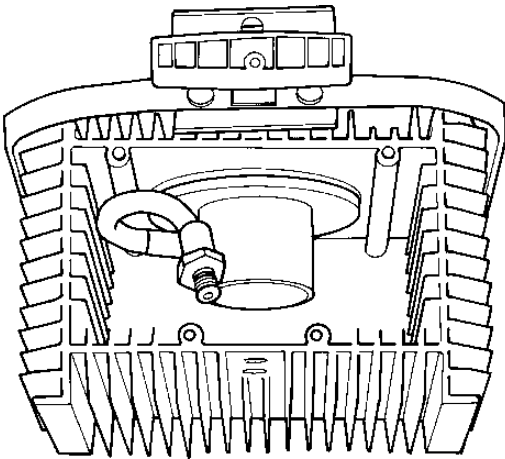

Lower the hydraulic pump into the tank (the hydraulic hose must be attached). Push the pump out through the opening against the tank adapter and tighten the four bolts.

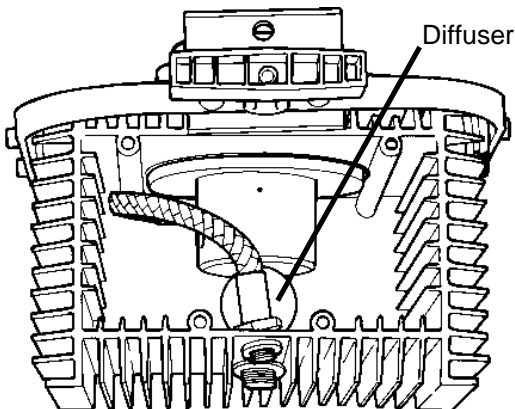

Fit the diffuser (17 socket).

Feed the hydraulic hose out through the upper hole in the tank wall. Fit the quick couplings.

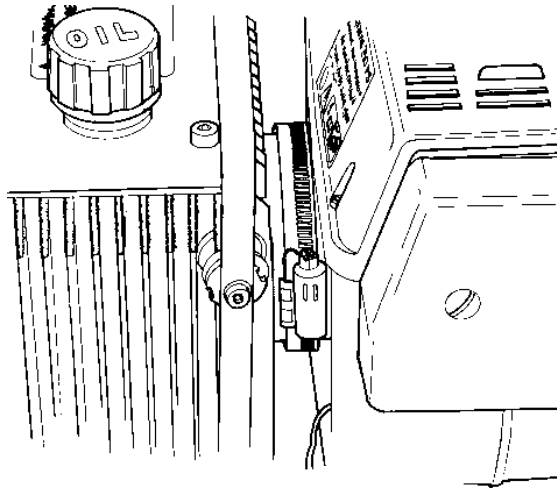

Screw the clutch drum on by turning it clockwise.
Connect the hydraulic oil tank to the engine unit.

Hydraulic pump Removal

Remove the clutch drum, tank adapter and diffuser.
Detach the hydraulic pump and lift it out. Disconnect the hydraulic hose.
Unscrew the 6 bolts in the cover and lift the cover off.

Remove the O ring, cog and pump cogs.

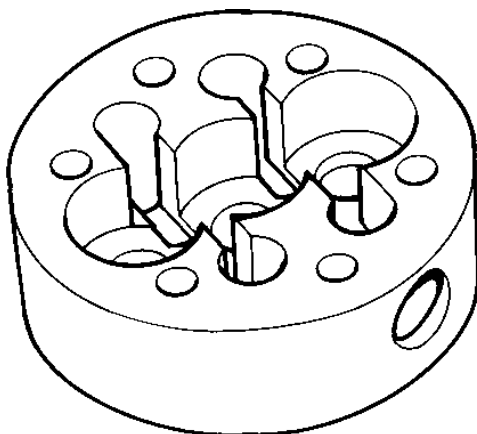
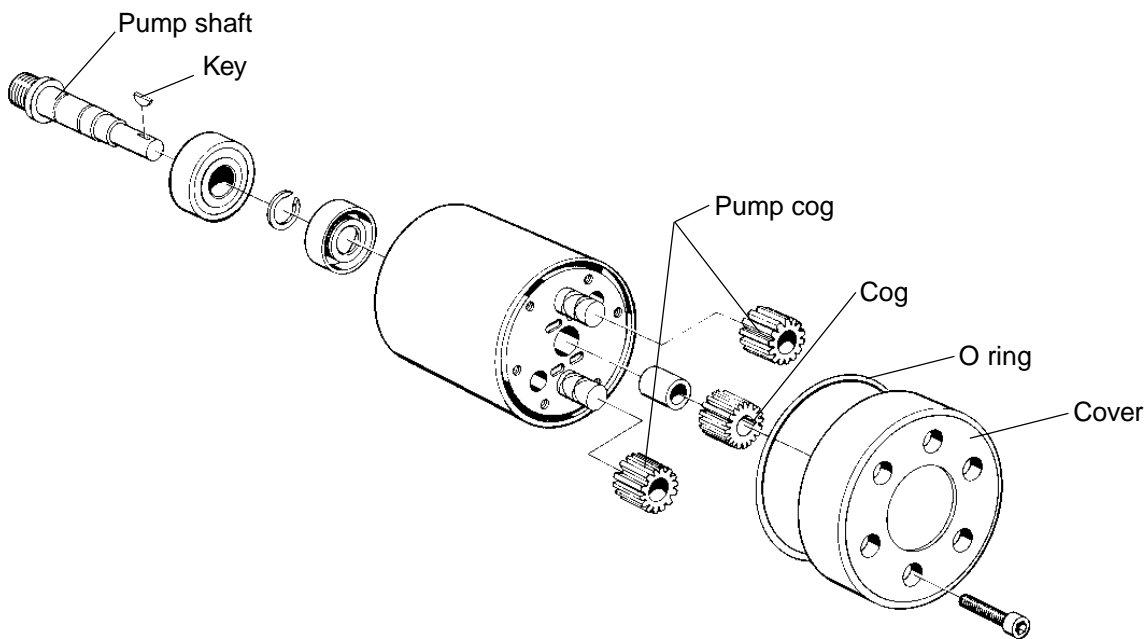

Check that the pump cams are free from gouges. If not, both pump cogs and the cover must be replaced. Make sure the pump cogs are not cracked or otherwise damaged.

9

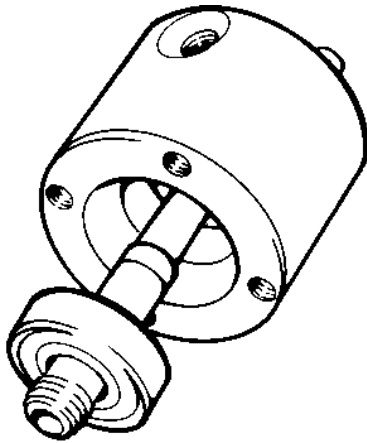

Heat the pump around the shaft and gently tap the shaft with a copper or lead mallet. If the shaft with its bearing and sealing ring does not come out then apply more heat.

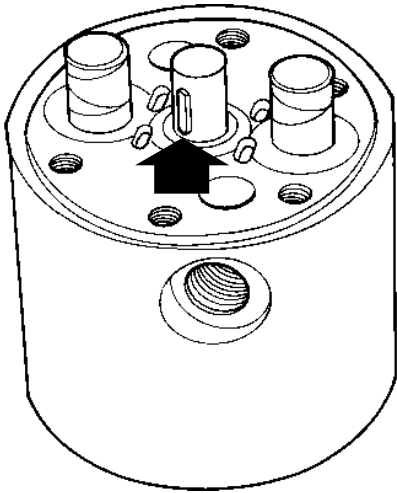

Assembly

Heat the pump and gently tap the pump shaft in. Place the key in the pump shaft. Fit the cog, pump cogs and O ring, then bolt on the cover. Fit the pump in the tank.

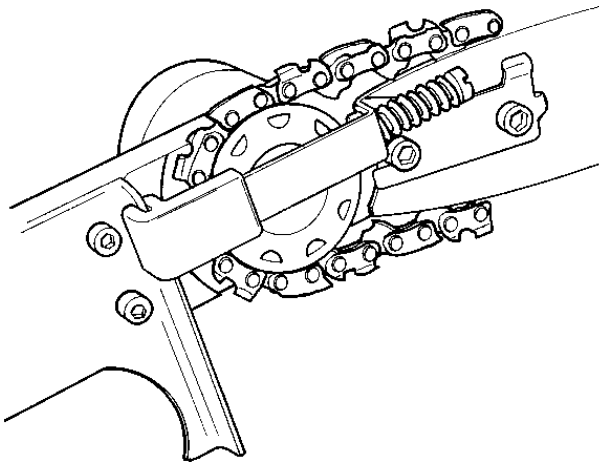

Bar and shaft

Removal

Remove the cover from the chain drive cog. Loosen the tensioning bolts and remove the chain tensioner, bar and chain.

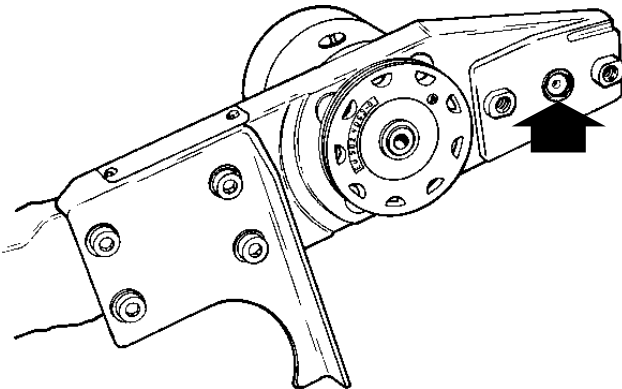

Do not lose the O ring that sits under the chain tensioner.

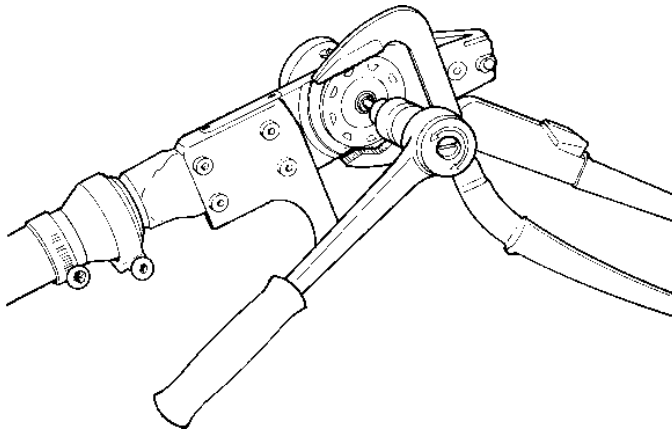

Undo the chain drive cog by holding the cog with a polygrip and inserting tool no. 502 52 13-01 (4 mm Allen key) into the shaft of the hydraulic motor. Turn the Allen key clockwise.

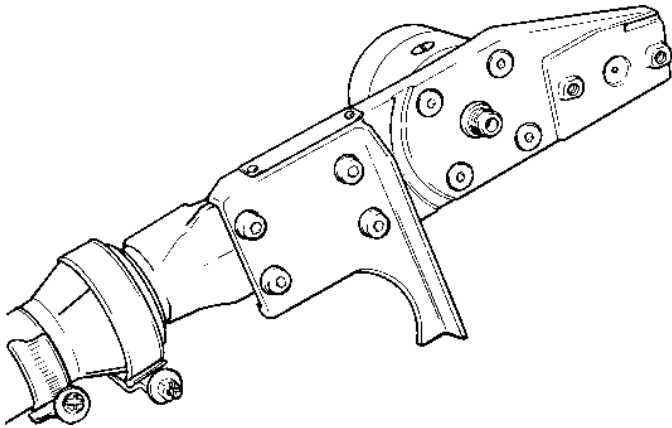

Remove the 4 bolts that hold the motor and the 4 bolts that hold the bar plate to the ball joint mounting.

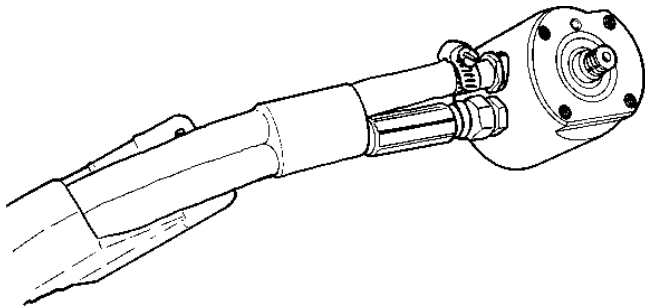

Disconnect the hoses from the motor (return hose = jubilee clip, pressure hose = hose coupling).

Slide off the rubber sheath that holds the two hoses together.

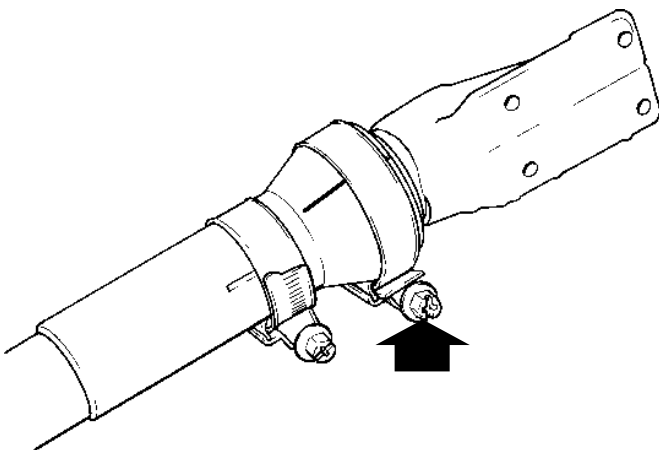

If necessary, dismantle the ball joint by first removing the jubilee clip, then prising off the ball joint mounting.

9

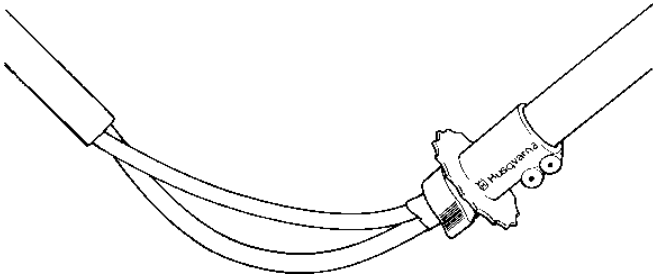

Separate the shaft tubes so that you can pull one hose at a time through the first tube. Start with the return hose.

Remove the shaft clips, if fitted.

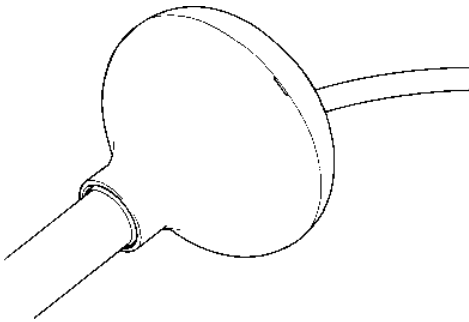

Pull the hoses through the second tube and third tube, if fitted. Replace the protective guards if necessary.

Assembly

Slide the protective guards onto the hose. Feed the hose through the larger shaft(s) and fit the shaft clips.

Feed both hoses through the smaller shaft, positioning the pressure hose slightly in front of the pressure hose.

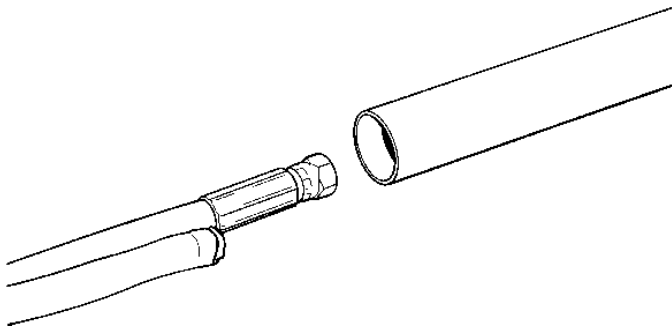

Fit the ball joint. The locating stud on the jubilee clip fits in the hole in the ball joint.

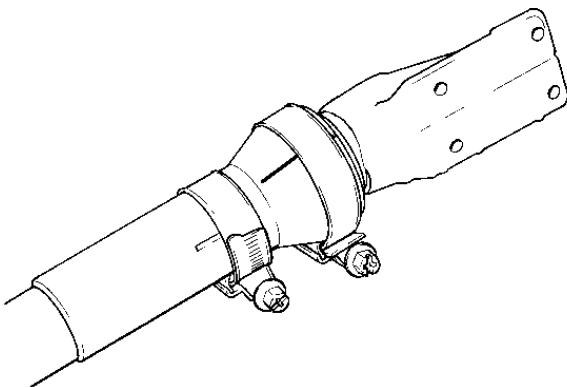

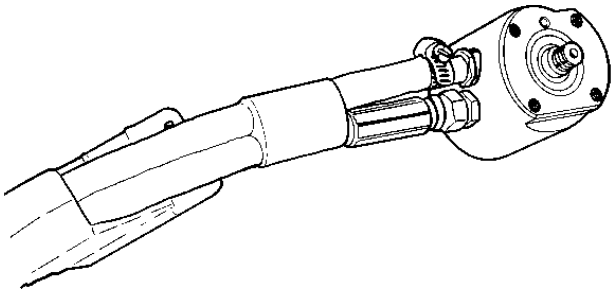

Fit the rubber sheath back in place and connect the hoses to the motor. Do not forget the jubilee clamp on the return hose.

Bolt the bar plate onto the ball joint mounting, fit the motor to the bar plate and screw on the chain drive cog.

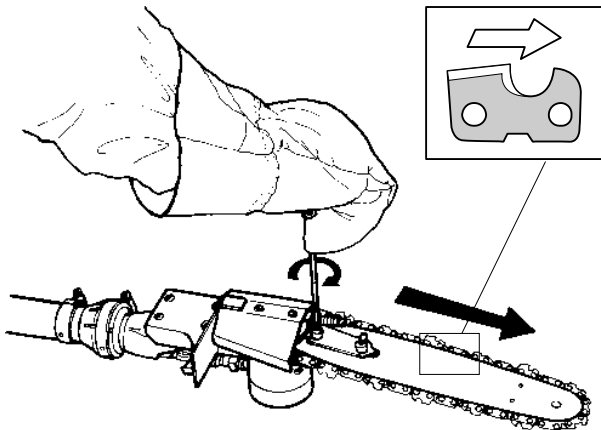

Place the bar as far back as it will go on the bar plate. Fit the gasket, chain tensioner, and bar bolts, tighten with your fingers.



WARNING! Always wear gloves when handling the chain.

Place the chain around the drive cog and the bar, making sure it sits correctly in the groove in the bar. The cutting edge on the chain links must face forward on top of the bar. Tighten the bolts.

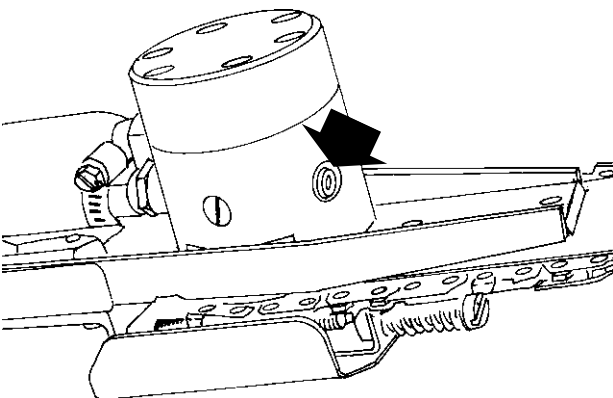

Hydraulic motor

The hydraulic motor is equipped with a small pressure relief valve. This opens if there is a blockage in the return hose. If it opens without cause it must be replaced. Use tool 502 42 50-01.

NOTE! The pressure relief valve may leak when the hydraulic oil is cold.

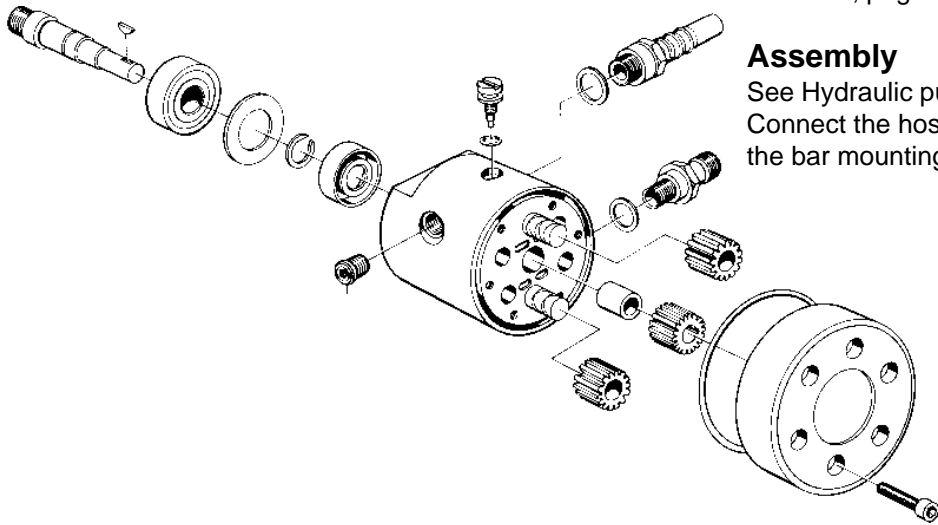

Removal

Disconnect the hydraulic motor from the bar mounting and hoses. For more information see Hydraulic pump, Removal, pages 41-42.

Assembly

See Hydraulic pump, Assembly, page 42. Connect the hoses to the motor and bolt the motor onto the bar mounting.

Replacing hose couplings.

If a hydraulic hose breaks near a hose coupling it can be repaired with a repair hose coupling. This hose coupling can be found in the list of spare parts, square P.

Remove the bar and detach the motor. (see page 43.) Disconnect the pressure hose and pull it out a short distance. Cut the hose square and fit the new hose coupling.



Start by screwing the left-hand threaded outer component of the hose coupling onto the hose as far as it will go. (Thread can be lubricated with engine oil or grease.)

NOTE! The black outer casing must not roll up. Screw the right-hand threaded inner component of the hose coupling inside the outer part.

Testing

Use the test hose, part no. 502 42 45-01 to test run the pruning saw.

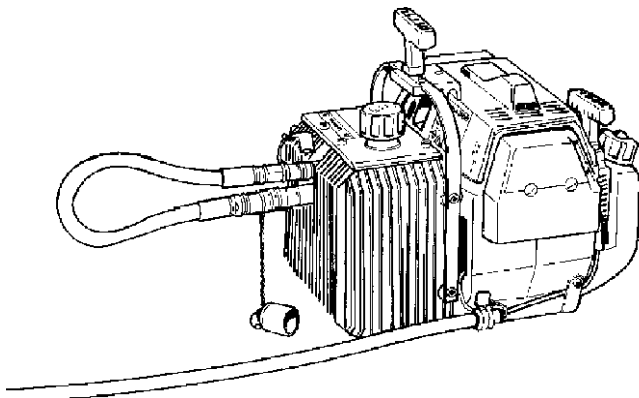

WARNING! Never start the pruning saw if the hydraulic oil tank and hoses are not fitted. If the hydraulic oil tank is not fitted the clutch may come loose and cause injury. If the hoses are not fitted the engine cannot be revved up and the hydraulic pump and clutch may be damaged.

Connect one end of the test hose (red cover) to the upper quick coupling on the hydraulic oil tank, and the other end (grey cover) to the lower quick coupling. Make sure the couplings click in place. Start the pruning saw.

For Husqvarna Parts Call 606-678-9623 or 606-561-4983



www.mymowerparts.com