

Complement to the spare parts list 1.1989

TECHNICAL UPDATING OF THE MODELS 40 AND 45

40/45

1. Crankshaft, Flywheel, Ignition Module

We have introduced two different ignition systems for the models 40 and 45. The changes are introduced on the model 40 from serial number 9101116 and on the model 45 from serial number 9251168.

On both models the conventional location of the key, in a keyway, have been replaced by a flywheel with a cast-in key. This means besides a new type of keyway in the crankshaft (see ill.) also that it is more easy to assemble.

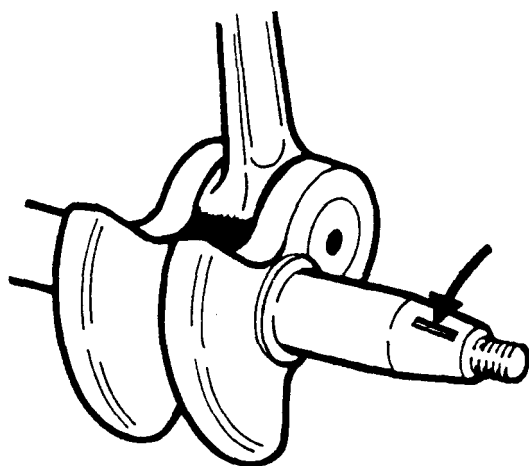

503 11 21-01

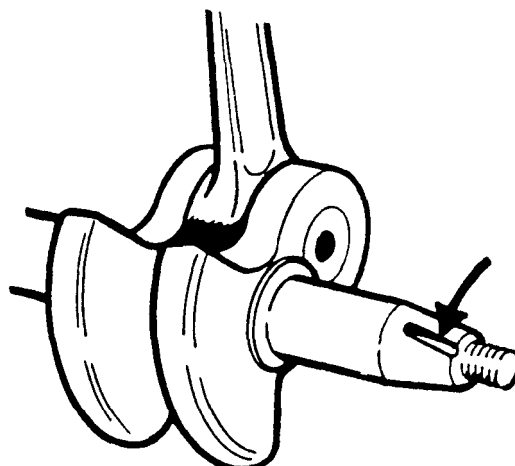

503 57 38-02

Please turn over

We have also introduced a Phelon-module on the models 40, where as the model 45 keep the present ignition module. This means two different flywheels which when mounted on a saw are separated by the different design of the ignition modules. Identification of not mounted flywheels is done by the casted-in Ref. No. (See ill.)

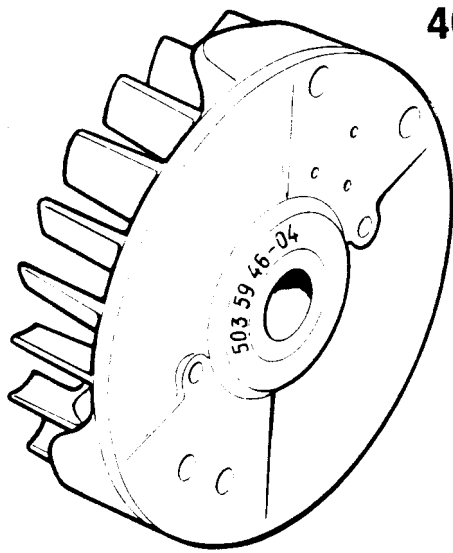

40

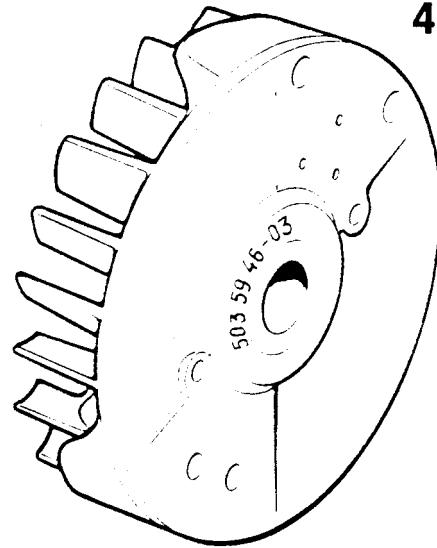

45

The table below and the following illustrations show what the change means:

40	45	New	Ref. No.	Description	Excluded Ref. No.	Remark
x	x	503 57	38-02	Crankshaft compl. Key	503 11 21-01 735 88 04-00	1 1
x		503 59	46-04	Flywheel compl.	506 03 13-09	1
	x	503 59	46-03	Flywheel compl.	506 313-09	1
x	x	503 23	01-01	Washer		
x	x	503 22	10-11	Nut	503 22 21-02	
x		503 58	05-01	Ignition module Phelon	506 02 72-01	2
x		501 48	54-03	Spark plug conn. compl. Phelon	501 48 54-02	2
x		506 01	37-01	Short circuit lead Phelon	506 01 37-02	2
x		503 60	62-01	Repair kit ign. lead Phelon	501 53 16-01	2, 3
x		506 01	06-07	Cylinder compl.	506 01 06-06	4

Please turn over

Remarks:

- 1 = Excluded Ref. No's remain as spare parts
- 2 = Excluded Ref. No's are still included in the model 45
- 3 = The Phelon ignition lead has a bigger diameter than the EM-module, and the end is casted-in. Therefore a repair kit is available with the Ref. No. 503 60 62-01 (see ill.)

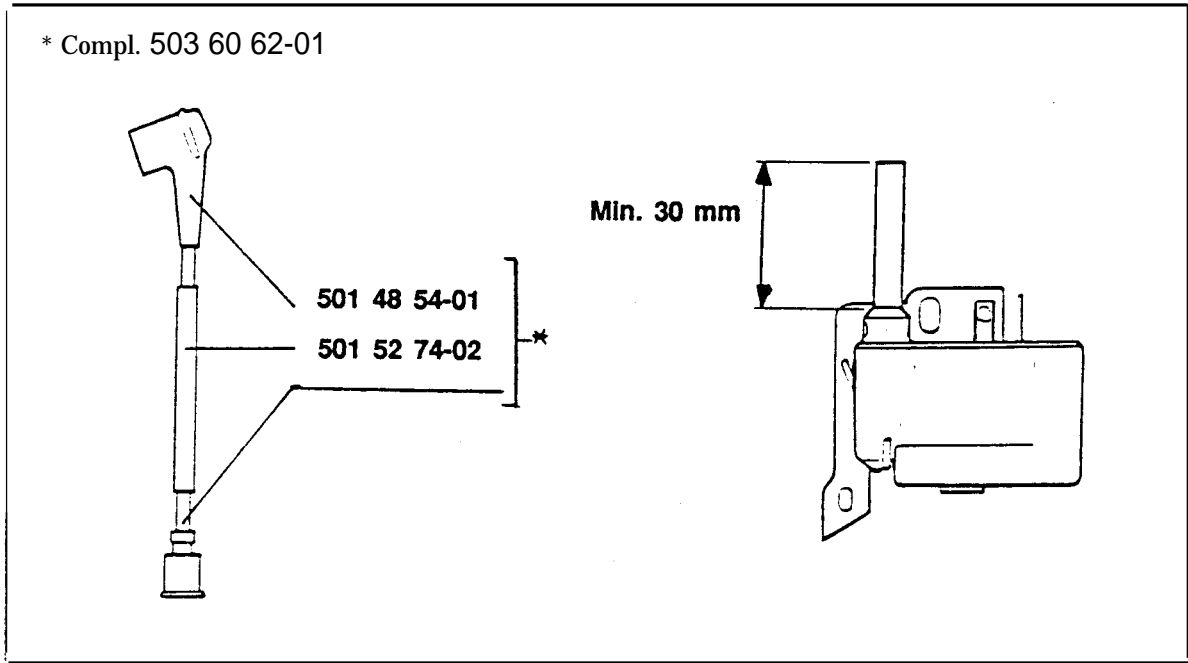

- 4 = A new cylinder is introduced together with the Phelon module. The cooling fins are made somewhat smaller behind the ignition module, comparing to the previous cylinder.
The Phelon-module only fits on cylinder Ref. No. 506 01 06-07.

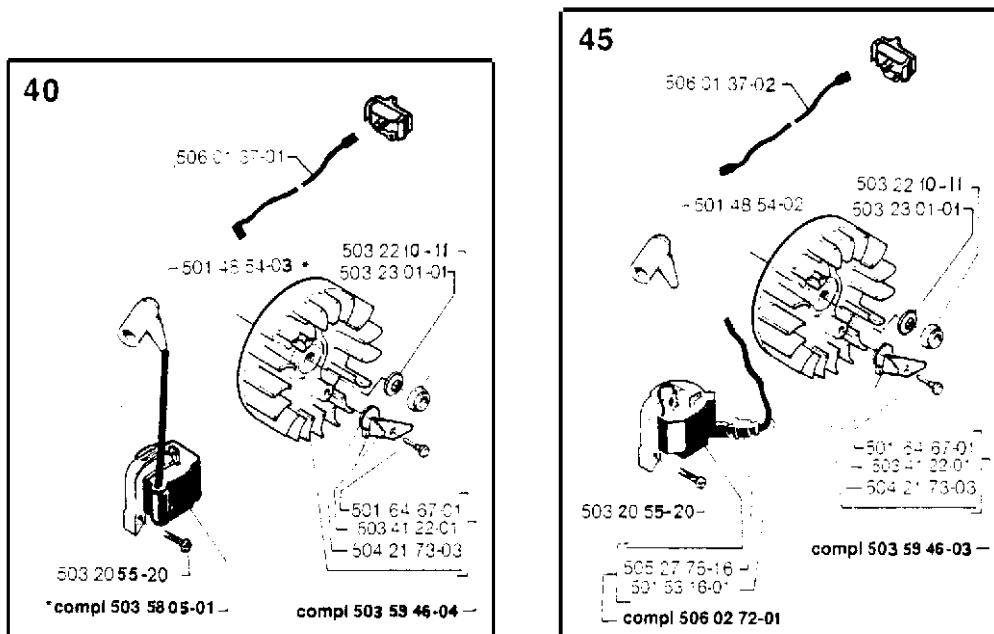

Please turn over

2. Carburetor

To improve the function of the carburetor and to increase the reliability, WT 99 replaces WT 17 D.

The difference between the two models is different main check nozzle valves. WT 99 has a mechanical valve, whereas WT 17 D has a screen. WT 99 has the advantage of not so easily being affected by dirt particles in the fuel.

New Ref. No.	Description	Excluded Ref. No.	Remark
503 28 13-20	Carburettor	502 10 03-03	1

Remark:

1 = The carburetors are fully interchangeable.

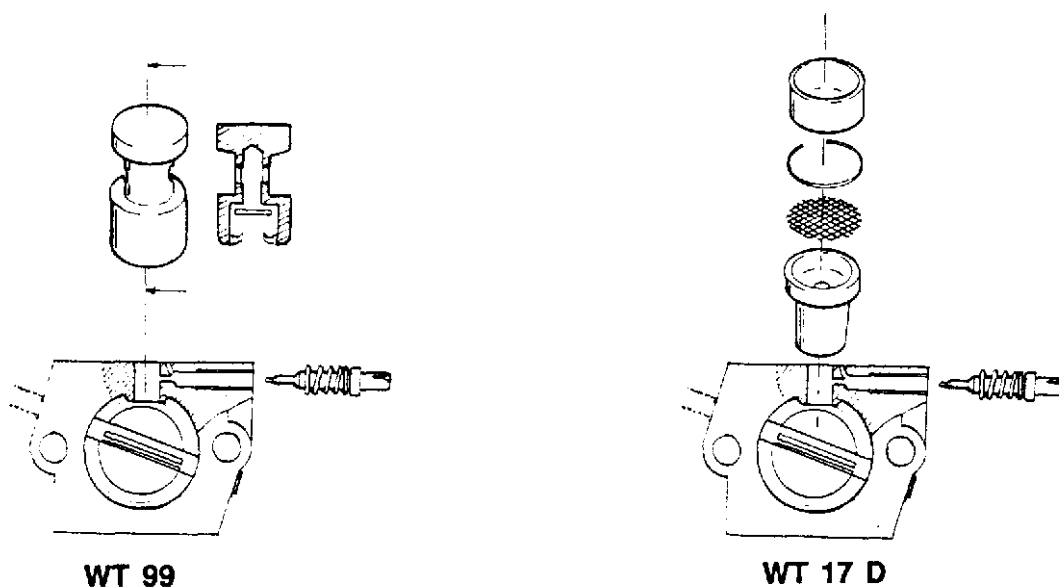

The change is introduced on the model:

40 from serial number 8390888

45 from serial number 8380395

Please turn over

3. Hand guard

In order to secure the return of the handguard to neutral position after tensioning, a positioning spring is placed inside the hand guard.

New Ref. No.	Description	Excluded Ref. No.	Remark
503 10 66-02	Hand guard compl.	503 10 66-01	1
503 53 91-01	Positioning spring		

Remark:

1 = -02 is fully interchangeable with -01.

The changed is introduced on the model: 40 from serial number 8520252
45 from serial number 9010351

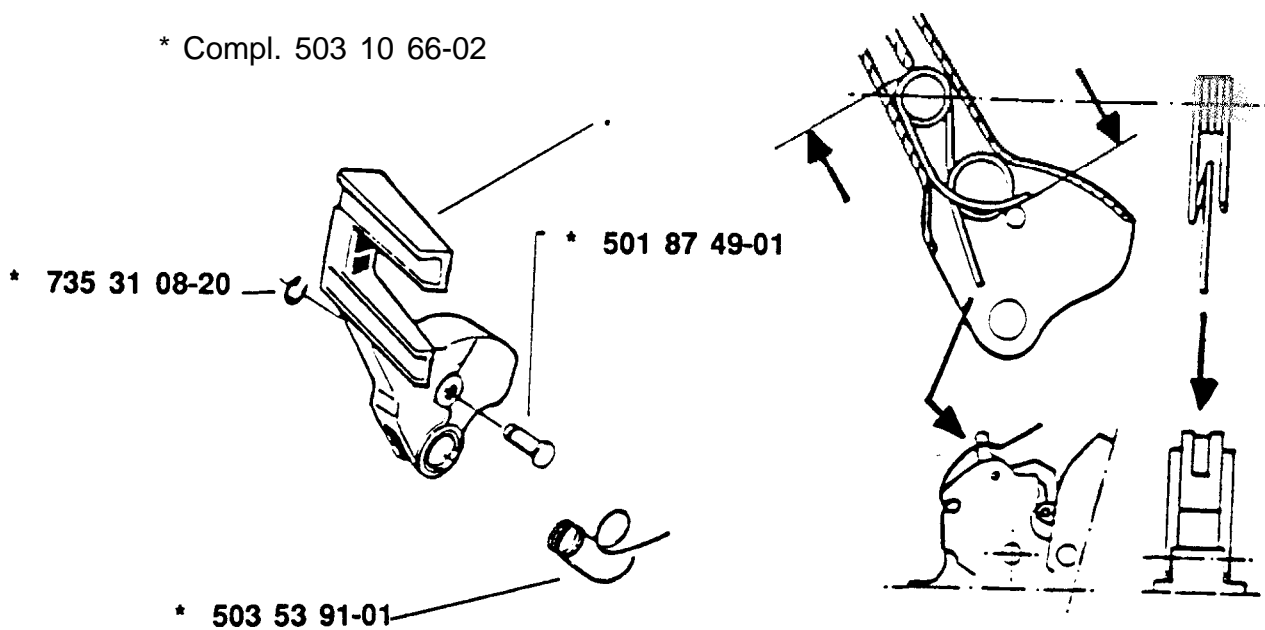

4. Throttle catch

In order to improve the positioning of the throttle cable cover in the rear handle, a stop cleat is introduced on the throttle catch.

New Ref. No.	Description	Excluded Ref. No.
506 01 45-04	Throttle catch	506 01 45-02

The change is introduced on the model: 40 from serial number 9050401
45 from serial number 9050297



Please turn over

5. Air filter

A new air filter is introduced. The filter has both an improved filtering capacity and longer life. The new airfilter has the Ref. No. 503 41 32-03 and is called "Non Woven". The previous filter Ref. No. 503 41 32-01 "Medium Mesh" and Ref. No. 503 41 32-02 "Flock" are excluded.

However Medium Mesh remains as a spare part.

The change is introduced on the models:

- 40 (version 01) from serial number 9020001
- 45 (version 11) from serial number 9020501

On the other versions the change will be introduced during autumn -89.

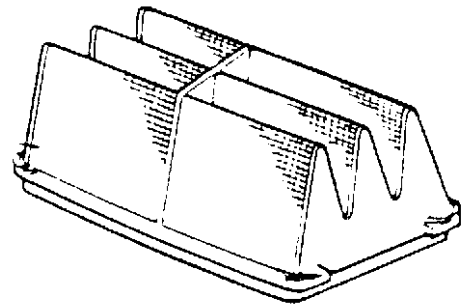

6. Silencer compl.

Silencer compl. has changed Ref. No. and the exhaust outlet to the SA-silencer is now available as a spare part.

New Ref. No.	Description	Excluded Ref. No.	Remark
503 59 51-01	Silencer (Standard)	506 01 17-01	-
503 59 51-02	Silencer (SA)	506 01 17-02	-
506 01 20-02	Exhaust outlet (SA)		

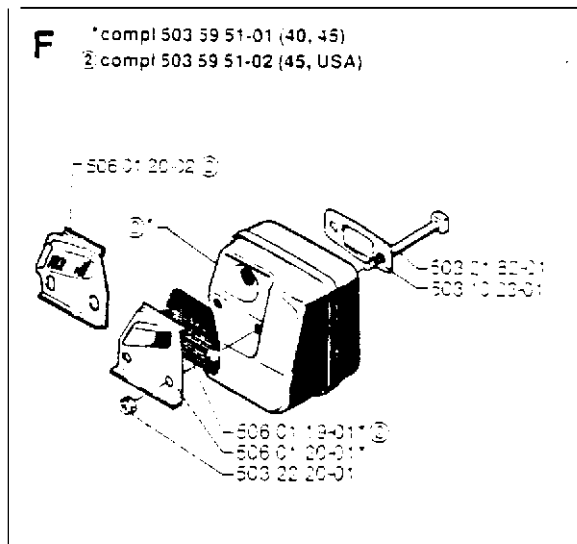

Spare parts list 1:1989

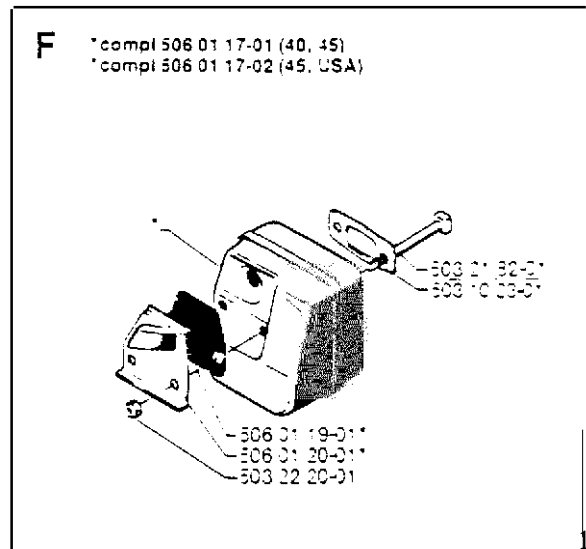

Spare parts list 1:1988

Please turn over

7. Stop switch

We have modified the stop switch, which means that the grip will be more accessible. The change was introduced on both models during the middle of November 1988. All saws, with serial number starting on 846, are equipped with the new stop switch.

New Ref. No.	Description	Excluded Ref. No.	Remark
503 48 65-02	Stop switch	503 48 65-01	-

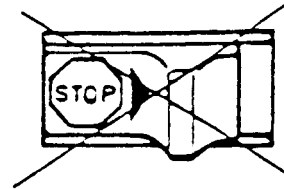
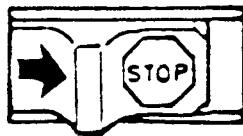

8. Fuel filter and fuel hose

The models 40 and 45 have earlier had special types of fuel filters. They have been equipped with a Walbro-filter and the other models have had a 70 microns standard filter. Now a finer mesh, 40 micron filter will replace the 70 micron filter, gradually on all models. This filter also replaces the Walbro filter.

New Ref. No.	Description	Excluded Ref. No.	Remark
503 44 32-01	Fuel filter	506 09 60-01	1
501 76 83-18	Fuel hose	501 76 83-19	-

Remark:

1 = Excluded Ref. No. remains as a spare part

The change is introduced on the model: 40 from serial number 9220001
45 from serial number 9220001

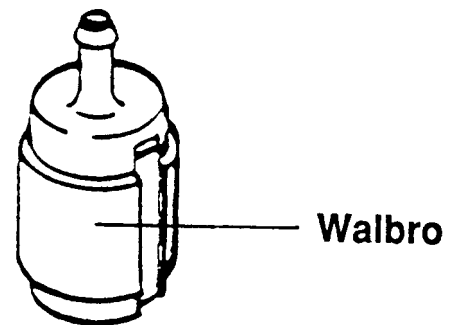
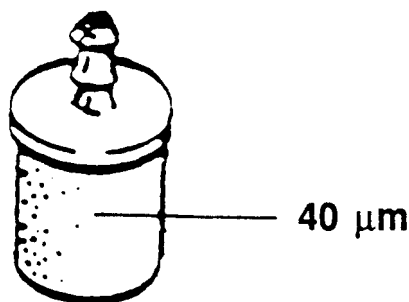

Please turn over

9. Inlet tube

On the contact surfaces of the inlet tube, against cylinder and the insulation wall of the carburettor, an inside radius is introduced in order to simplify mounting at service work.

New Ref. No.	Description	Excluded Ref. No.	Remark
506 01 32-02	Inlet tube	506 02 32-01	-

The change is introduced on the model: 40 from serial number 9080242
 45 from serial number 9090390

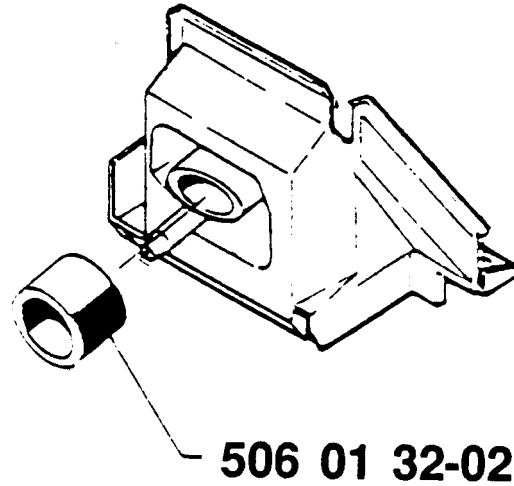

10. Chain catcher

When a new tank unit was introduced, the mounting of the chain catcher was changed also. Even the design was changed. In Service Bulletin X 88.129-26 sent out earlier, it was mentioned that the new tank unit is equipped with chain catcher Ref. No. 506 03 16-04. The old one has the Ref. No. 506 03 16-02.

In order to reduce your parts inventory Ref. No. 506 03 16-02 is excluded, because -04 can also fit the old tank after a small modification. The two chain catchers are identical with the exception of a post on the -04. The post has to be removed before it is put on the old tank. This is easily done by using a knife.



506 03 16-04

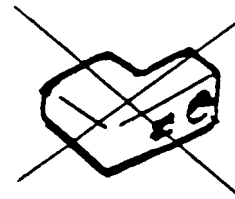

506 03 16-02