

For Husqvarna Parts Call 606-678-9623 or 606-561-4983

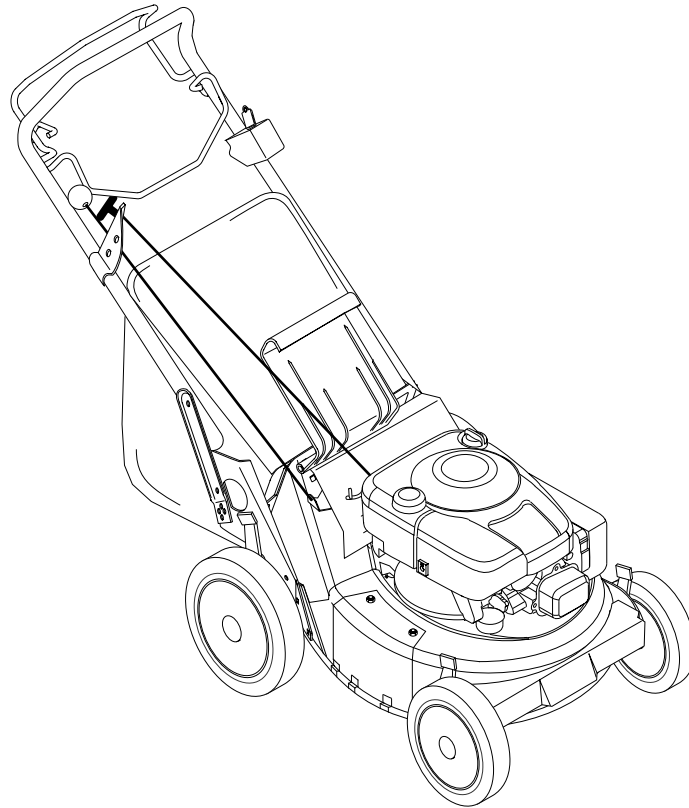

**580 R, 580 RS, 580 RSE,
580 RSW, 580 BBC, 600 C**

Part's Manual

606 00 02 97 6/01
Printed in USA

www.mymowerparts.com

THE MANUAL

Before you operate your unit, carefully and completely read manuals supplied with the unit. The contents will provide you with an understanding of safety instructions and controls during normal operation and maintenance.

For your safety and the safety of others always read, understand, and follow all DANGER, WARNING, and CAUTION messages found in manuals and on safety decals.

Hardware descriptions are given in decimals.

Decimals to Fractions			
.063	1/16	.563	9/16
.125	1/8	.625	5/8
.188	3/16	.688	11/16
.250	1/4	.750	3/4
.313	5/16	.813	13/16
.375	3/8	.875	7/8
.438	7/16	.938	15/16
.500	1/2	1.00	1

SERVICE AND REPLACEMENT PARTS

When ordering replacement parts or making service inquiries, know the Model and Serial numbers of your unit and engine.

Numbers are located on the product registration card in the unit literature package. They are printed on a serial number label, located on the frame of your unit.

- Record Unit Model and Serial numbers here:

- Record Engine Model and Serial numbers here:

UNAUTHORIZED REPLACEMENT PARTS

Use only Husqvarna replacement parts. The replacement of any part on this vehicle with anything other than a Husqvarna authorized replacement part may adversely affect the performance, durability, or safety of this unit and may void the warranty. Husqvarna disclaims liability for any claims or damages, whether warranty, property damage, personal injury or death arising out of the use of unauthorized replacement parts.

PRODUCT REGISTRATION

Please fill out and return the Warranty Registration Card to Husqvarna. This card activates the warranty. Claims meeting requirements during limited warranty period will be honored.

YOUR SATISFACTION IS IMPORTANT

Questions? Please follow these helpful steps:

1. Refer to the manuals supplied with your unit.
They will guide you through safe and proper operation and maintenance.
They contain specifications on your unit.
If your questions are not answered in these manuals, go to step number two.
2. Contact Your Dealer.
Our dealers will be happy to supply any service or advice required to keep your unit operating at peak efficiency.
A factory trained staff is available to support your equipment needs. They stock genuine Husqvarna parts and lubricants manufactured with the same precision and skill as the original.
If your questions are not resolved by the support staff, ask for the manager or owner.
When contacting your Dealer supply your model and serial numbers.

TO SPEED PARTS ORDERING:

1. Know the model and serial numbers of your unit.
2. Know the part number required.
3. Know the quantity required.
4. Know the part description.

MODELS

Model 601 10 00 20 (580 RS)

4 Cycle-Briggs & Stratton Intek OHV 6.5 HP
Recoil, Self-Propelled
Serial No. 000101 and up

Model 601 10 00 21 (580 RSE)

4 Cycle-Briggs & Stratton Intek OHV 6.5 HP
Electric, Self-Propelled
Serial No. 000101 and up

Model 601 10 00 22 (580 RSW)

4 Cycle-Briggs & Stratton Intek OHV 6.5 HP
Recoil, Self-Propelled, Swivel
Serial No. 000101 and up

Model 601 10 00 23 (600 C)

4 Cycle-Robin 6.0 HP
Recoil, Self-Propelled, Commercial
Serial No. 000101 and up

Model 601 10 00 24 (580 R)

4 Cycle-Briggs & Stratton Intek OHV 6.5 HP
Recoil
Serial No. 000101 and up

Model 601 10 00 25 (580 BBC)

4 Cycle-Briggs & Stratton Intek OHV 6.5 HP
Recoil, Self-Propelled
Serial No. 000101 and up

TABLE OF CONTENTS

DECALS

Decals 4

MAIN FRAME & ENGINE

Handlebar and Controls 6
Mower Pan and Bag 8
Blade and Belt 10
Engine and Electrical 11
Engine-BBC 12

WHEELS

Swivel Wheels and Brackets 13
Wheels and Adjusters 14
Friction Wheel and Adjusters 16

ELECTRICAL AND CONTINUITY DIAGRAMS

Electrical and Continuity Diagram 18

DECALS

Model 580 R, 580 RS, 580 RSE, 580 RSW, 580 BBC, 600 C

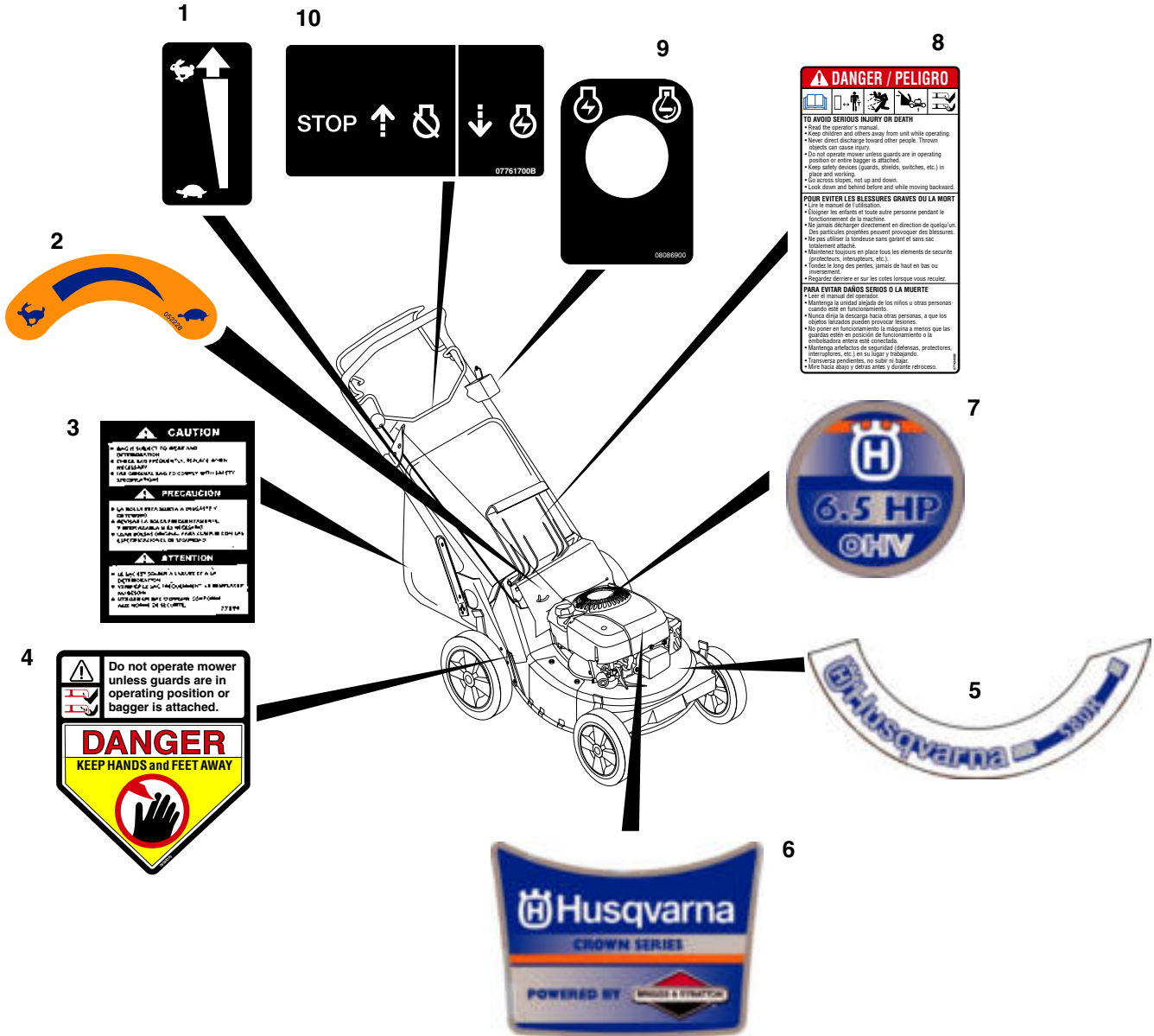

PM0191

DECALS

Model 580 R, 580 RS, 580 RSE, 580 RSW, 580 BBC, 600 C

Item	Part No.	Qty.	Description
1	606 00 00 12	1	Decal, Speed Control
2	606 00 00 04	1	Decal, Swoosh Husqvarna
3	606 00 00 07	1	Label, Bagger 21"
4	606 00 00 09	1	Decal, Danger
5	606 00 02 99	1	Decal, 580 R
	606 00 00 05	1	Decal, 580 RS
	606 00 02 48	1	Decal, 580 RSE
	606 00 02 49	1	Decal, 580 RSW
	606 00 03 01	1	Decal, 580 BBC
	606 00 02 50	1	Decal, 600 C
6	606 00 02 51	1	Decal, Husqvarna & Robin (600 C)
	606 00 02 52	1	Decal, Husqvarna-Briggs & Stratton Intek OHV (580 R, 580 RS, 580 RSE, 580 RSW, 580 BBC)
7	606 00 02 53	1	Decal, Robin 6HP OHV-Commercial (600 C)
	606 00 02 54	1	Decal, OHV 6.5 Husqvarna (580 R, 580 RS, 580 RSE, 580 RSW, 580 BBC)
8	606 00 00 08	1	Decal, Bilingual Danger
9	606 00 03 18	1	Decal, Key Switch (580 RSE)
10	606 00 00 13	1	Decal, Engine Control

HANDLEBAR AND CONTROLS

Model 580 R, 580 RS, 580 RSE, 580 RSW, 580 BBC, 600 C

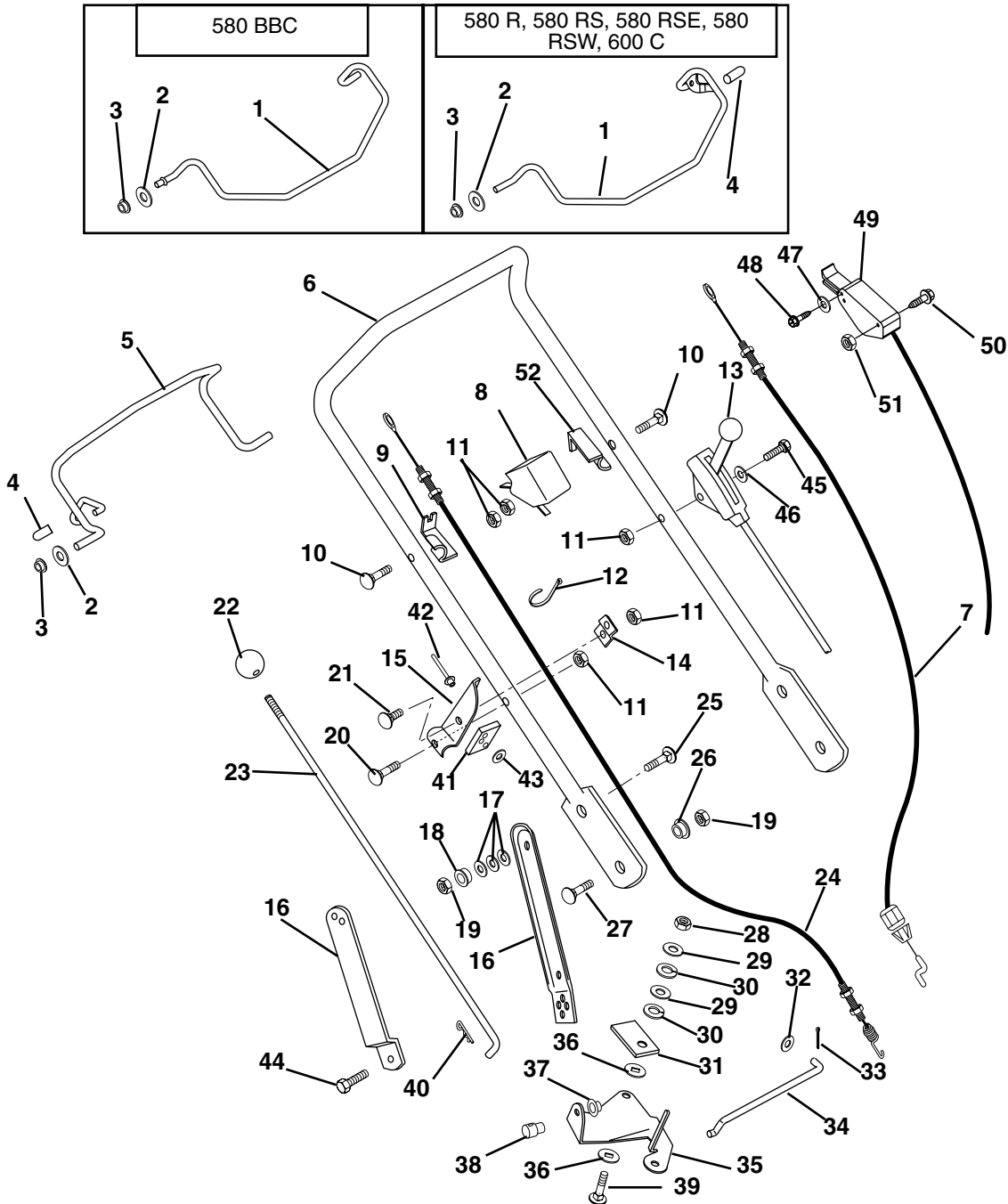

PM0026

Item	Part No.	Qty.	Description
1	606 00 00 30	1	Engine Bail Weldment(580 R, 580 RS, 580 RSE, 580 RSW, 600 C)
	606 00 02 89	1	Bail- Blade Brake/Clutch(580 BBC)
2	606 00 00 45	4	Washer-Flat-Steel .32 x .44 x .44 x .56 (580 R, 580 RS, 580 RSE, 580 RSW, 600 C)
	606 00 00 45	3	Washer-Flat-Steel .32 x .44 x .44 x .56(580 BBC)
3	606 00 00 34	4	Bushing-Flange .325 x .688 x .560 (580 R, 580 RS, 580 RSE, 580 RSW, 600 C)
	606 00 00 34	3	Bushing-Flange .325 x .688 x .560(580 BBC)
4	606 00 00 60	2	Cap, Vinyl .25 I.D. (580 R, 580 RS, 580 RSE, 580 RSW, 600 C)
	606 00 00 60	1	Cap, Vinyl .25 I.D. (580 BBC)
5	606 00 00 29	1	Traction Bail(580 RS, 580 RSE, 580 RSW, (580 BBC, 600 C)
6	606 00 00 31	1	Handlebar

HANDLEBAR AND CONTROLS

Model 580 R, 580 RS, 580 RSE, 580 RSW, 580 BBC, 600 C

Item	Part No.	Qty.	Description
7	606 00 00 56	1	Engine Control Cable(580 R, 580 RS, 580 RSE, 580 RSW)
	606 00 00 57	1	Engine Control Cable(600 C)
8	606 00 00 26	1	Switch-Cable Anchor(580 RSE)
9	606 00 00 19	1	Cable Anchor-Right Hand
10	606 00 00 39	2	Bolt-Round Head Square Neck .25-20 x 1.25(580 R, 580 RS, 580 RSE, 580 RSW, 600 C)
	606 00 00 39	1	Bolt-Round Head Square Neck .25-20 x 1.25(580 BBC)
11	606 00 00 49	5	Nut-Locking-Center .25-20(580 R, 580 RS, 580 RSE, 580 RSW, 600 C)
	606 00 00 49	4	Nut-Locking-Center .25-20(580 BBC)
12	606 00 00 61	3	Cable Tie
13	606 00 00 58	1	Throttle Cable(600 C)
	606 00 03 03	1	Throttle Cable(580 BBC)
14	606 00 00 22	1	Brace-Speed Control
15	606 00 00 18	1	Bracket-Speed Control
16	606 00 00 23	1	Link-Handlebar Adjuster Left Hand (580 R, 580 RS, 580 RSE, 580 RSW, 580 BBC)
	606 00 00 24	1	Link-Handlebar Adjuster Right Hand (580 RS, 580 RSE, 580 RSW, 580 BBC)
	606 00 00 27	2	Handlebar Bracket(600 C)
17	606 00 00 32	6	Washer-Bellville Spring(580 R, 580 RS, 580 RSE, 580 RSW, 580 BBC)
18	606 00 00 35	2	Bushing-Flange .325 x .50 x .513 x .875(580 R, 580 RS, 580 RSE, 580 RSW, 580 BBC)
19	606 00 00 50	4	Nut-Locking-Center .31-18
20	606 00 00 42	1	Bolt-Round Head Square Neck .25-20 x 1.38
21	606 00 00 40	1	Bolt-Round Head Square Neck .25-20 x .50 Grade 5
22	606 00 00 59	1	Knob (511, 514-516, 522)
23	606 00 00 21	1	Rod-Speed Control(580 RS, 580 RSE, 580 RSW, 580 BBC, 600 C)
24	606 00 00 55	1	Traction Cable(580 RS, 580 RSE, 580 RSW, 580 BBC, 600 C)
25	606 00 00 38	2	Bolt-Round Head Square Neck .31-18 x 1.00 Grade 5(580 R, 580 RS, 580 RSE, 580 RSW, 580 BBC)
26	606 00 00 33	2	Shoulder Spacer
27	606 00 00 37	2	Bolt-Round Head Square Neck .31-18 x .75 Grade 5(580 R, 580 RS, 580 RSE, 580 RSW, 580 BBC)
	606 00 00 38	2	Bolt-Round Head Square Neck .31-18 x 1.00 Grade 5(600 C)
28	606 00 00 48	1	Nut-Locking-Center .38-16(580 RS, 580 RSE, 580 RSW, 580 BBC, 600 C)
29	606 00 00 44	2	Washer-Flat-Steel .406 x .812 x .065(580 RS, 580 RSE, 580 RSW, 580 BBC, 600 C)
30	606 00 02 74	2	Washer-Lock .375 x .115 Heavy(580 RS, 580 RSE, 580 RSW, 580 BBC, 600 C)
31	606 00 00 25	1	Pressure Flange(580 RS, 580 RSE, 580 RSW, 580 BBC, 600 C)
32	606 00 00 46	1	Washer-Flat-Steel .281 x .620 x .065(580 RS, 580 RSE, 580 RSW, 580 BBC, 600 C)
33	606 00 00 51	1	Pin-Cotter .06 x .50(580 RS, 580 RSE, 580 RSW, 580 BBC, 600 C)
34	606 00 00 17	1	Shift Link(580 RS, 580 RSE, 580 RSW, 580 BBC, 600 C)
35	606 00 00 16	1	Bell Crank-Speed Control(580 RS, 580 RSE, 580 RSW, 580 BBC, 600 C)
36	606 00 00 15	2	Friction Washer(580 RS, 580 RSE, 580 RSW, 580 BBC, 600 C)
37	606 00 00 14	1	Cap, Rod .375(580 RS, 580 RSE, 580 RSW, 580 BBC, 600 C)
38	606 00 00 20	1	Swivel(580 RS, 580 RSE, 580 RSW, 580 BBC, 600 C)
39	606 00 00 41	1	Bolt-Round Head Square Neck .38-16 x 1.25(580 RS, 580 RSE, 580 RSW, 580 BBC, 600 C)
40	606 00 00 52	1	Pin-Hair-Internal .08 x .18 x 1.18(580 RS, 580 RSE, 580 RSW, 580 BBC, 600 C)
41	606 00 00 28	1	Support Pad(580 RS, 580 RSE, 580 RSW, 580 BBC, 600 C)
42	606 00 00 53	2	Rivet .187 x .575(580 RS, 580 RSE, 580 RSW, 580 BBC, 600 C)
43	606 00 00 47	2	Washer-Flat Steel .219 x .50 x .049(580 RS, 580 RSE, 580 RSW, 580 BBC, 600 C)
44	606 00 00 36	2	Bolt-Hex .31-18 x .75 Grade 5(600 C)
45	606 00 02 76	1	Bolt-Round Head Square Neck .25-20 x 1.75 Grade 5(600 C)
	606 00 03 21	1	Bolt-Round Head Square Neck .25-20 x 1.75 XL(580 BBC)
46	606 00 02 75	1	Washer-Flat-Steel .250 x .562 x .049(600 C)
	606 00 03 22	1	Washer-Flat-Steel .281 x .62 x .065(580 BBC)
47	606 00 00 47	1	Washer-Flat-Steel .219 x .50 x .049(580 BBC)
48	606 00 03 23	1	Screw-Tapping 10-24 x .50 Hex Washer Head(580 BBC)
49	606 00 03 04	1	Control- Blade Brake/Clutch(580 BBC)
50	606 00 03 24	2	Screw-Machine 10-24X2.00 Hex Washer Head(580 BBC)
51	606 00 03 25	2	Nut-Hex 10-24(580 BBC)
52	606 00 02 72	1	Cable Anchor-Left Hand(580 R, 580 RS, 580 RSW, 600 C)

MOWER PAN AND BAG

Model 580 R, 580 RS, 580 RSE, 580 RSW, 580 BBC, 600 C

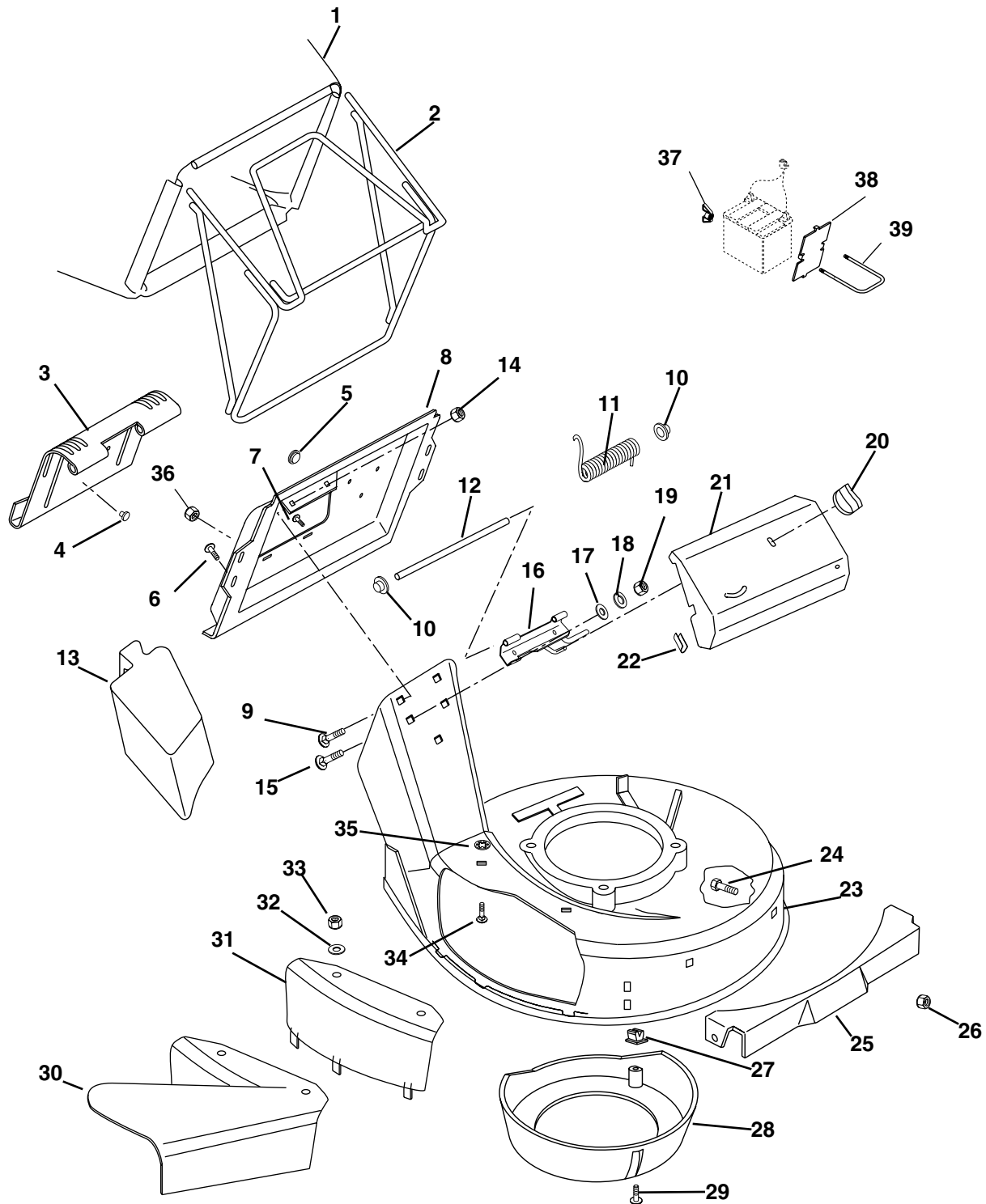

PM0033

MOWER PAN AND BAG

Model 580 R, 580 RS, 580 RSE, 580 RSW, 580 BBC, 600 C

Item	Part No.	Qty.	Description
1	606 00 00 76	1	Bag-ConsumerSilver
2	606 00 00 63	1	Bagger Frame
3	606 00 00 62	1	Door-Catcher Plate
4	606 00 00 97	1	Button Bumper
5	606 00 00 96	2	Bumper
6	606 00 00 92	4	Screw-Tapping 12-24 x .50 Hex Washer (580 R, 580 RS, 580 RSE, 580 RSW, 580 BBC)
7	606 00 00 93	2	Screw-Tapping 10-24 x .38 Pan Head
8	606 00 00 70	1	Plate-Catcher(580 R, 580 RS, 580 RSE, 580 RSW, 580 BBC)
9	606 00 00 79	2	Bolt-Round Head Square Neck .25-20 x .38
10	606 00 00 78	2	Nut-Push
11	606 00 00 98	1	Spring-Torsion .120 x .68 x 3.09
12	606 00 00 64	1	Pin-Door
13	606 00 01 00	1	Mulch Master Mulcher Accessory
14	606 00 00 88	2	Nut-Locking-Flange .25-20
15	606 00 00 81	2	Bolt-Round Head Square Neck .25-20 x .75 Grade 5
16	606 00 00 67	1	Hinge Base Weldment(580 RS, 580 RSW, 580 BBC, 600 C)
	606 00 03 16	1	Hinge Base (580 R)
17	606 00 00 85	1	Washer-Flat-Steel .328 x .87 x .179
18	606 00 00 83	2	Washer-Locking .25 x .077
19	606 00 00 90	2	Nut-Hex .25-20
20	606 00 00 69	1	Nut-Wing(580 RS, 580 RSW, 580 BBC, 600 C)
21	606 00 00 68	1	Drive Cover(580 RS, 580 RSW, 580 BBC, 600 C)
22	606 00 00 66	2	Trim Bumper
23	606 00 00 99	1	Mower Pan Head with Decals(580 RS, 580 RSW, 580 BBC, 600 C)
	606 00 02 87	1	Mower Pan with Decals (580 BBC)
	606 00 02 88	1	Mower Pan with Decals (580 R)
24	606 00 00 82	2	Bolt-Round Head Square Neck .31-18 x .50 Grade 5 (580 RS, 580 RSE, 580 RSW)
25	606 00 00 65	1	Front Panel
26	606 00 00 50	2	Nut-Locking-Center .31-18 (580 RS, 580 RSE, 580 RSW, 600 C)
27	606 00 00 95	3	Grommet-Plastic
28	606 00 00 72	1	Baffle-Center
29	606 00 00 94	3	Screw-Tapping 10-16 x .62 Hex Washer Head
30	606 00 00 77	1	Side Discharge Assembly
31	606 00 00 75	1	Side Discharge Cover
32	606 00 00 44	2	Washer-Flat-Steel .406 x .812 x .065
33	606 00 00 89	2	Nut-Locking-Nylon .312-18
34	606 00 00 80	2	Bolt-Round Head Square Neck .31-18 x .75 Grade 2
35	606 00 00 86	2	Nut-Push .312
36	606 00 00 88	4	Nut-Locking-Flange .250-20(600 C)
37	606 00 00 91	2	Nut-Wing #8-32
38	606 00 00 73	1	Battery Plate (580 RSE)
39	606 00 00 74	1	U-Bolt(580 RSE)

BLADE AND BELT

Model 580 R, 580 RS, 580 RSE, 580 RSW, 600 C

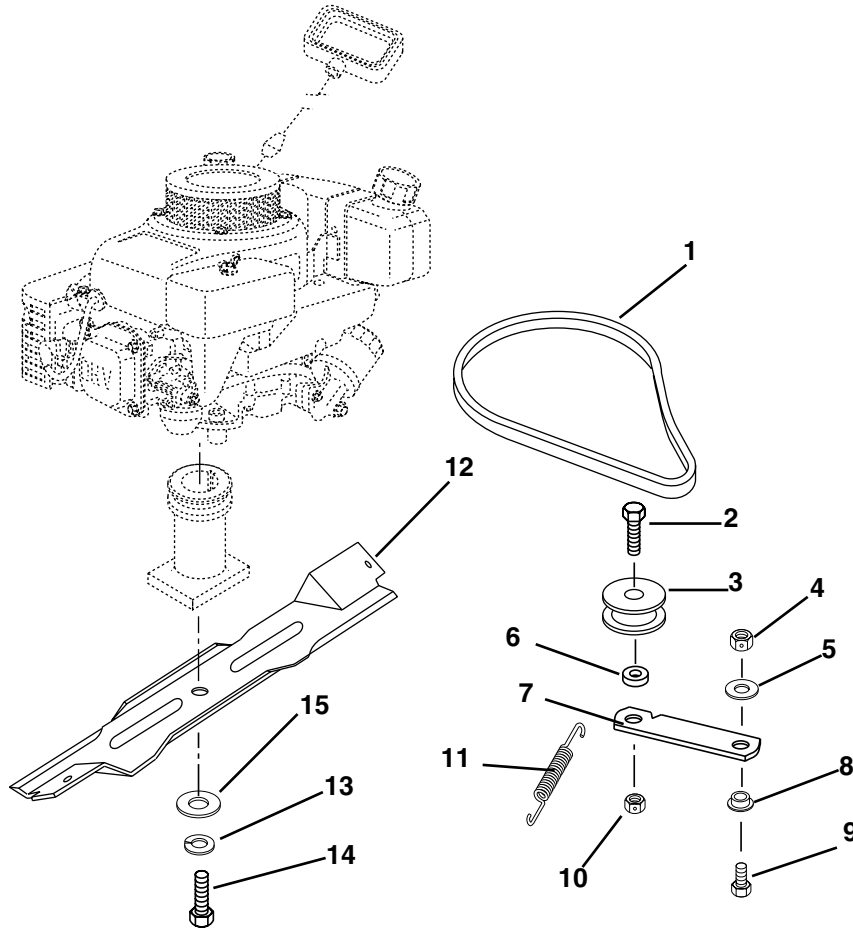

PM0141

Item	Part No.	Qty.	Description
1	606 00 02 26	1	V-Belt 3L Section(580 RS, 580 RSE, 580 RSW, 600 C)
2	606 00 02 20	1	Bolt-Hex .44-14 x 1.25 Grade 5(580 RS, 580 RSE, 580 RSW, 600 C)
3	606 00 02 27	1	Idler-Flat 1.75 x .47(580 RS, 580 RSE, 580 RSW, 600 C)
4	606 00 00 50	4	Nut-Locking-Center .31 -18(580 RS, 580 RSE, 580 RSW, 600 C)
5	606 00 02 22	1	Washer-Flat-Steel .323 x .625 x .062(580 RS, 580 RSE, 580 RSW, 600 C)
6	606 00 02 16	1	Spacer .52 x .45 x .34(580 RS, 580 RSE, 580 RSW, 600 C)
7	606 00 02 15	1	Idler Arm(580 RS, 580 RSE, 580 RSW, 600 C)
8	606 00 02 17	1	Bushing-Flange .325 x .501 x .250 x 1.120(580 RS, 580 RSE, 580 RSW, 600 C)
9	606 00 00 36	1	Bolt-Hex .31-18 x .75 Grade 5(580 RS, 580 RSE, 580 RSW, 580 BBC, 600 C)
10	606 00 02 25	1	Nut-Locking-Center .44-14(580 RS, 580 RSE, 580 RSW, 600 C)
11	606 00 02 28	1	Spring, Tension .043 x .44 x 3.31(580 RS, 580 RSE, 580 RSW, 600 C)
12	606 00 00 03	1	Blade, 21" Mower
13	606 00 00 43	1	Washer-Locking .38 x .094
14	606 00 02 19	1	Bolt-Hex .38-24 x 2.00 Grade 8
15	606 00 02 23	1	Washer-Flat Steel .390 x 1.50 x .125

ENGINE AND ELECTRICAL

Model 580 R, 580 RS, 580 RSE, 580 RSW, 600 C

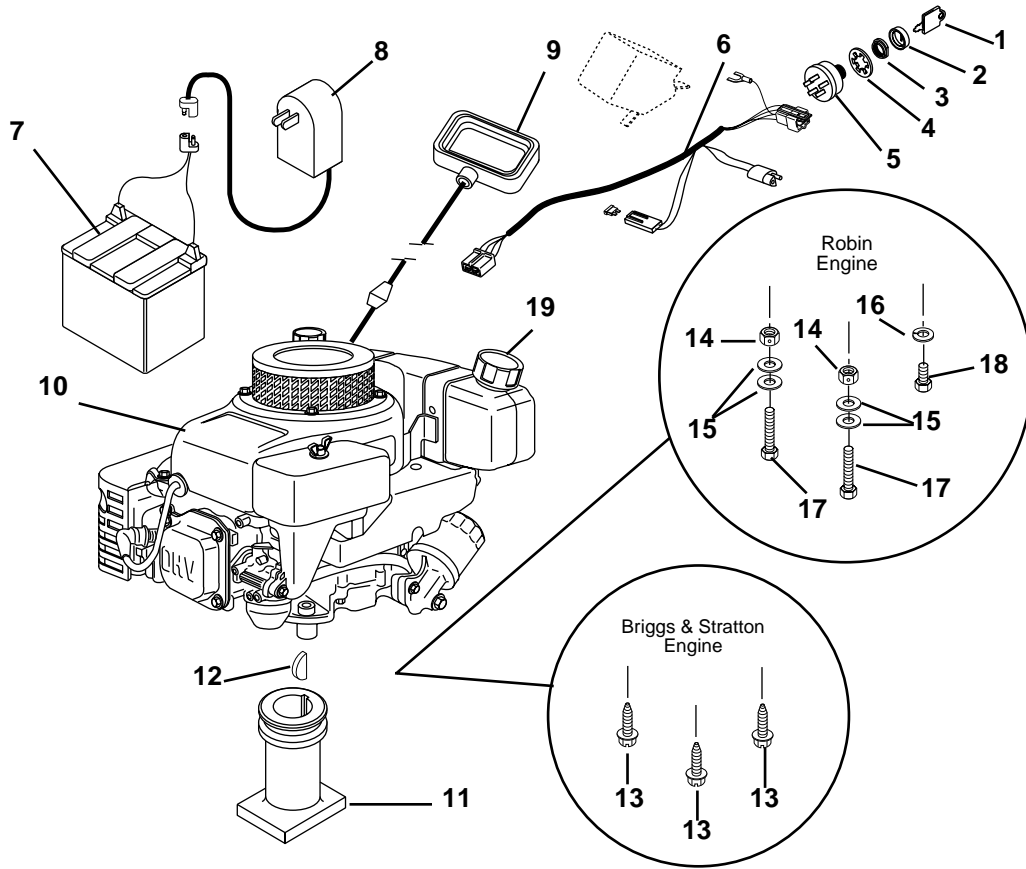

PM0133

Item	Part No.	Qty.	Description
1	606 00 02 36	1	Key with Cap(580 RSE)
2	606 00 02 47	1	Cap-Ignition Switch(580 RSE)
3	606 00 02 42	1	Nut, Panel .625-32(580 RSE)
4	606 00 02 39	1	Washer-Locking Internal .625 x .045(580 RSE)
5	606 00 03 20	1	Switch, Key Electric Start-LM(580 RSE)
6	606 00 03 19	1	Harness, Wire LM-Electric(580 RSE)
7	606 00 02 34	1	Battery (515)(580 RSE)
8	606 00 02 30	1	Battery Charger(580 RSE)
9	606 00 02 32	1	Recoil Start Handle
10*		1	Engine, Robin 6 HP 4 Cycle(600 C)
		1	Engine, Briggs & Stratton Intek OHV 6.5HP Recoil(580 R, 580 RS, 580 RSW)
		1	Engine, Briggs & Stratton Intek OHV 6.5HP Electric Start(580 RSE)
11	606 00 02 33	1	Adapter, Blade .875 Dia with Keyway(580 R, 580 RS, RSE, RSW)
	606 00 02 29	1	Adapter, Blade(600 C)
12	606 00 02 44	2	Key-Woodruff .156 x .625 x .25 SAE #6(580 R, 580 RS, 580 RSE, 580 RSW)
	606 00 02 44	1	Key-Woodruff .156 x .625 x .25 SAE #6 (600 C)
13	606 00 02 45	3	Screw-Tapping .38-16 x 1.00 Hex Washer Head
14	606 00 00 50	2	Nut-Locking-Center .31-18(600 C)
15	606 00 02 41	4	Washer-Flat-Steel .312 x .734 x .065(600 C)
16	606 00 01 99	1	Washer-Locking .312 x .097 Heavy(600 C)
17	606 00 02 38	2	Bolt-Hex .31-18 x 1.25 Grade 5(600 C)
18	606 00 00 36	1	Bolt-Hex .31-18 x .75 Grade 5(600 C)
19	606 00 03 29	1	Fuel Cap (Robin 6 HP engine only - for other brands, call your engine parts supplier)

*See your Dealer for Engine Specifications

ENGINE-BBC

Model 580 BBC

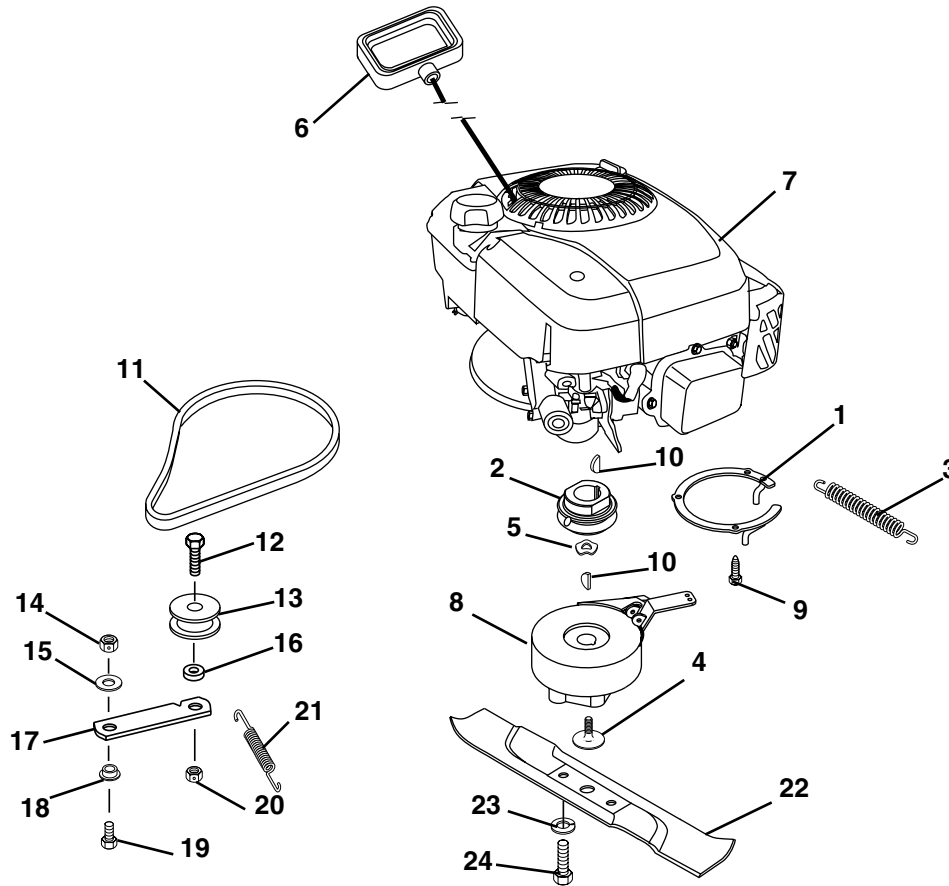

PM0451

Item	Part No.	Qty.	Description
1	606 00 02 93	1	Bracket- Spring Retainer
2	606 00 02 94	1	Pulley- Blade Brake/Clutch
3	606 00 02 28	1	Spring-Tension .1278 x .735 x 4.71
4	606 00 03 17	1	Screw-Socket Head-Special .375-24 x 1.50
5	606 00 03 07	1	Washer-Wave .88 x 1.31 x .125
6	606 00 02 32	1	Recoil Start Handle
7*		1	Engine, Briggs & Stratton Intek OHV 6.5HP Recoil
8	606 00 02 90	1	Blade Brake Clutch
9	606 00 02 45	3	Screw-Tapping .38-16 x 1.00 Hex Washer Head
10	606 00 02 44	2	Key-Woodruff .156 x .625 x .25
11	606 00 02 26	1	V-Belt 3L Section
12	606 00 02 20	1	Bolt-Hex .44-14 x 1.50 Grade 5
13	606 00 02 27	1	Idler-Flat 1.75 x .47
14	606 00 00 50	1	Nut-Locking-Center .31 -18
15	606 00 02 22	1	Washer-Flat-Steel .323 x .625 x .062
16	606 00 03 02	1	Bushing-Sleeve .469 x .750 x .430
17	606 00 02 15	1	Idler Arm
18	606 00 02 17	1	Bushing-Flange .325 x .501 x .250 x 1.120
19	606 00 00 36	1	Bolt-Hex .31-18 x .75 Grade 5
20	606 00 02 25	1	Nut-Locking-Center .44-14
21	606 00 02 28	1	Spring, Tension .043 x .44 x 3.31
22	606 00 02 91	1	Blade- Blade Brake/Clutch
23	606 00 03 27	2	Washer-Locking .44 x .109 Regular
24	606 00 03 28	2	Bolt-Hex M10 x 1.5 x 25

*See your Dealer for Engine Specifications

SWIVEL WHEELS AND BRACKETS

Model 580 RSW

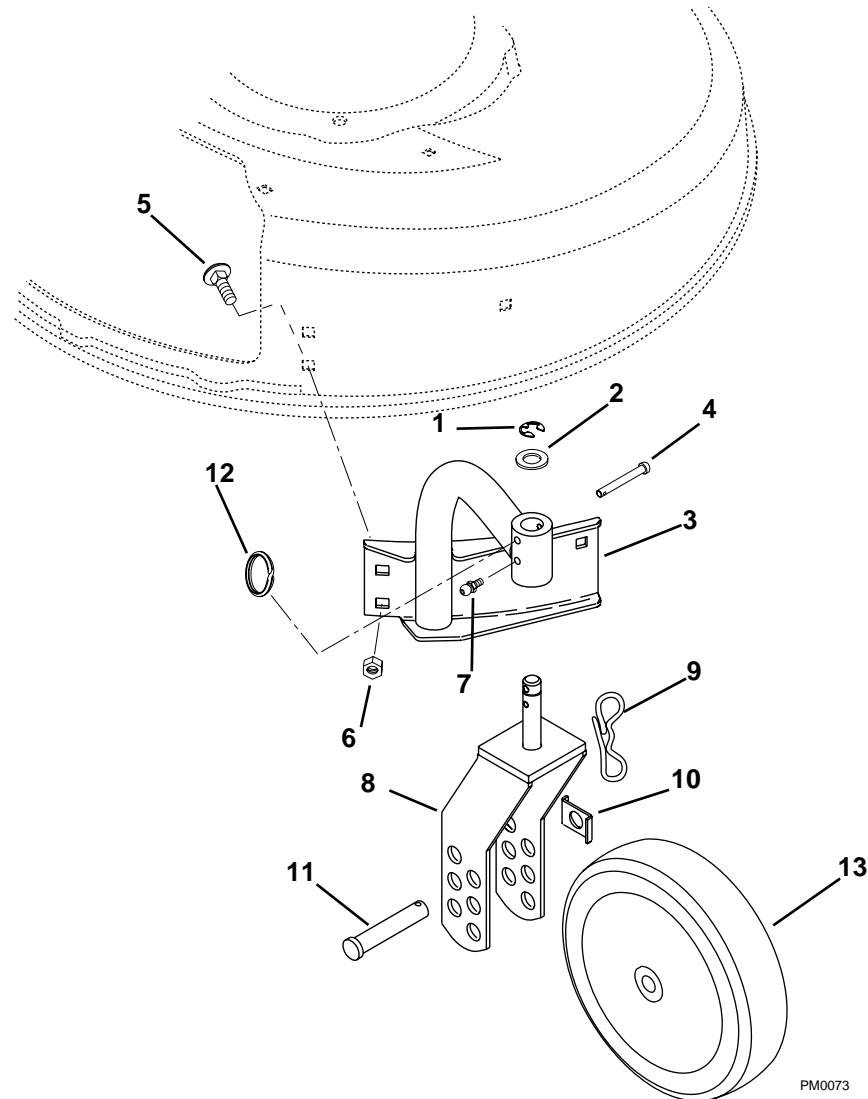

PM0073

Item	Part No.	Qty.	Description
1	606 00 01 51	2	Ring-Retaining-External .625 x .042
2	606 00 01 53	2	Washer-Flat-Steels .630 x 1.005 x .062
3	606 00 01 47	1	Mount with Bushing, Right Arm
	606 00 01 48	1	Mount with Bushing, Left Arm
4	606 00 01 56	2	Pin-Clevis .25 x 1.75
5	606 00 00 82	6	Bolt-Round Head Square Neck .31-18 x .50 Grade 5
6	606 00 01 36	6	Nut-Hex .312-18
7	606 00 01 57	2	Fitting-Lube .25-28 x .256
8	606 00 01 46	2	Wheel Yoke Weldment
9	606 00 01 55	2	Pin, Bowtie Cotter
10	606 00 01 43	2	Axle Tab
11	606 00 01 44	2	Pin-Clevis .494 x 2.62
12	606 00 01 45	2	Ring-Kickout
13	606 00 02 80	2	Wheel-7.50 O.D. Steel Swivel

WHEELS AND ADJUSTERS

Model 580 R, 580 RS, 580 RSE, 580 RSW, 580 BBC, 600 C

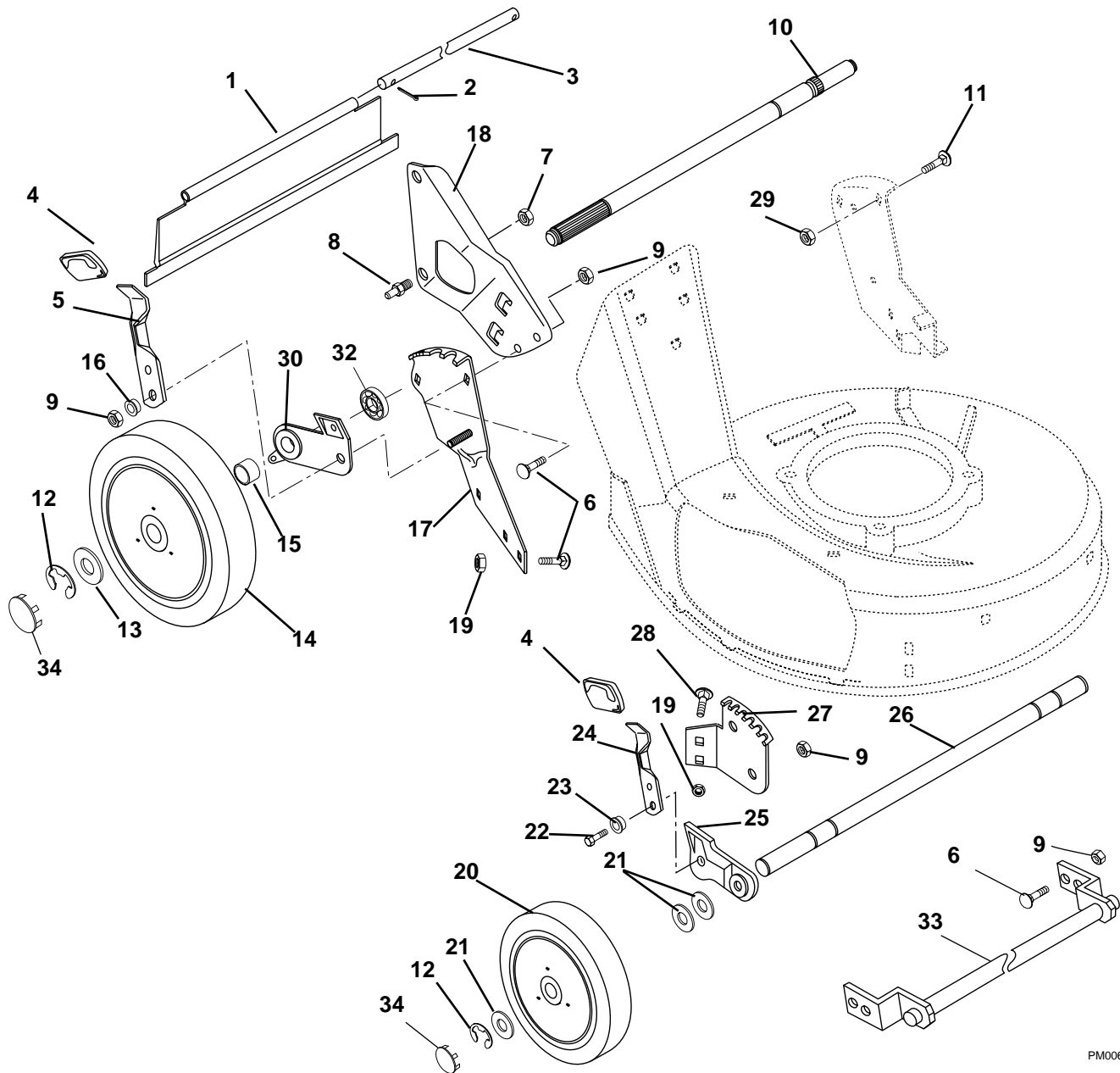

PM0065

Item	Part No.	Qty.	Description
1	606 00 01 42	1	Rear Protective Guard, Self Propelled(580 RS, 580 RSE, 580 RSW, 580 BBC, 600 C)
	606 00 03 15	1	Rear Protective Guard, Push (580 R)
2	606 00 00 51	3	Pin-Cotter .06 x .50
3	606 00 01 08	1	Rod
4	606 00 01 41	4	Knob (580 R, 580 RS, 580 RSE, 580 BBC, 600 C)
	606 00 01 41	2	Knob (580 RSW)
5	606 00 01 04	2	Height Adjustment Lever
6	606 00 01 27	9	Bolt-Round Head Square Neck .31-18 x .62 (580 R, 580 RS, 580 RSE, 580 RSW, 580 BBC)
	606 00 01 27	13	Bolt-Round Head Square Neck .31-18 x .62 (600 C)
7	606 00 00 48	2	Nut-Locking-Center .38-16

WHEELS AND ADJUSTERS

Model 580 R, 580 RS, 580 RSE, 580 RSW, 580 BBC, 600 C

Item	Part No.	Qty.	Description
8	606 00 01 19	2	Handlebar Stud
9	606 00 00 50	8	Nut-Locking-Center .31-18 (580 R, 580 RS, 580 RSE, 580 RSW, 580 BBC)
	606 00 00 50	12	Nut-Locking-Center .31-18 (600 C)
10	606 00 01 09	1	Rear Axle (580 RS, 580 RSE, 580 RSW, 580 BBC, 600 C)
	606 00 03 10	1	Rear Axle Push Mower (580 R)
11	606 00 01 28	1	Bolt-Round Head Square Short Neck .31-18 x 1.00
12	606 00 01 25	4	Ring-Retaining-External .500 x .042
	606 00 01 25	2	Ring-Retaining-External .500 x .042
13	606 00 01 30	2	Washer-Flat-Steel .505 x .880 x .072
14	606 00 02 78	1	Wheel,Left Hand Rear (580 RS, 580 RSE, 580 RSW, 580 BBC)
	606 00 02 79	1	WheelRight Hand Rear (580 RS, 580 RSE, 580 RSW, 580 BBC, 600C)
	606 00 03 09	2	Wheel, Push (580 R)
15	606 00 01 10	2	Spacer Tube (580 RS, 580 RSE, 580 RSW, 580 BBC, 600 C)
	606 00 03 11	1	Spacer Tube-Push Left Hand (580 R)
	606 00 03 12	1	Spacer Tube-Push Right Hand (580 R)
16	606 00 01 23	2	Bushing-Flange .312 x .500 x .344 x .880
17	606 00 01 14	1	Rear Quadrant-Left Hand
	606 00 01 15	1	Rear Quadrant-Right Hand
18	606 00 01 07	1	Bracket-Handlebar Mounting-Right Hand
	606 00 01 06	1	Bracket-Handlebar Mounting-Left Hand
19	606 00 01 36	10	Nut-Locking-Flanged .31-18 (580 R, 580 RS, 580 RSE, 580 BBC, 600 C)
20	606 00 02 77	2	Wheel-Front (580 R, 580 RS, 580 RSE, 580 BBC, 600 C)
21	606 00 01 32	6	Washer-Flat-Steel .520 x .827 x .062 (580 R, 580 RS, 580 RSE, 580 BBC, 600 C)
22	606 00 01 26	2	Bolt-Hex .31-18 x 1.00 Grade 5 (580 R, 580 RS, 580 RSE, 580 BBC, 600 C)
23	606 00 01 23	2	Bushing-Flange .312 x .500 x .344 x .880 (580 R, 580 RS, 580 RSE, 580 BBC, 600 C)
24	606 00 01 03	2	Lever, Front Height Adjustment (580 RS, 580 RSE,)
25	606 00 01 01	1	Left Hand Bracket Assembly
	606 00 01 02	1	Right Hand Bracket Assembly
26	606 00 01 20	1	Front Axle (580 R, 580 RS, 580 RSE, 580 BBC, 600 C)
27	606 00 01 12	1	Front Quadrant, Left Hand (580 R, 580 RS, 580 RSE, 580 BBC, 600 C)
	606 00 01 13	1	Front Quadrant, Right Hand (580 R, 580 RS, 580 RSE, 580 BBC, 600 C)
28	606 00 00 82	4	Bolt-Round Head Square Neck .31-18 x .50 Grade 5 (580 R, 580 RS, 580 RSE, 580 BBC, 600 C)
29	606 00 00 89	1	Nut-Locking-Nylon .31-18
30	606 00 01 05	1	Rear Adjuster Bracket-Left Hand (580 RS, 580 RSE, 580 RSW, 600 C)
	606 00 01 11	1	Rear Bracket and Bearing Assembly - Right Hand (580 RS, 580 RSE, 580 RSW)
	606 00 01 17	1	Rear Adjuster Bracket-Right Hand (600 C)
31	606 00 01 30	2	Washer-Flat-Steel .505 x .880 x .072(580 R, 580 RS, 580 RSE, 600C)
32	606 00 01 22	1	Bearing-Ball .625 x 1.383 x .50 (600 C)
33	606 00 01 16	1	De-Thatcher Retainer Weldment (600 C)
34	606 00 03 08	4	Cap, Hub

FRICTION WHEEL AND DRIVE

Model 580 R, 580 RS, 580 RSE, 580 RSW, 580 BBC, 600 C

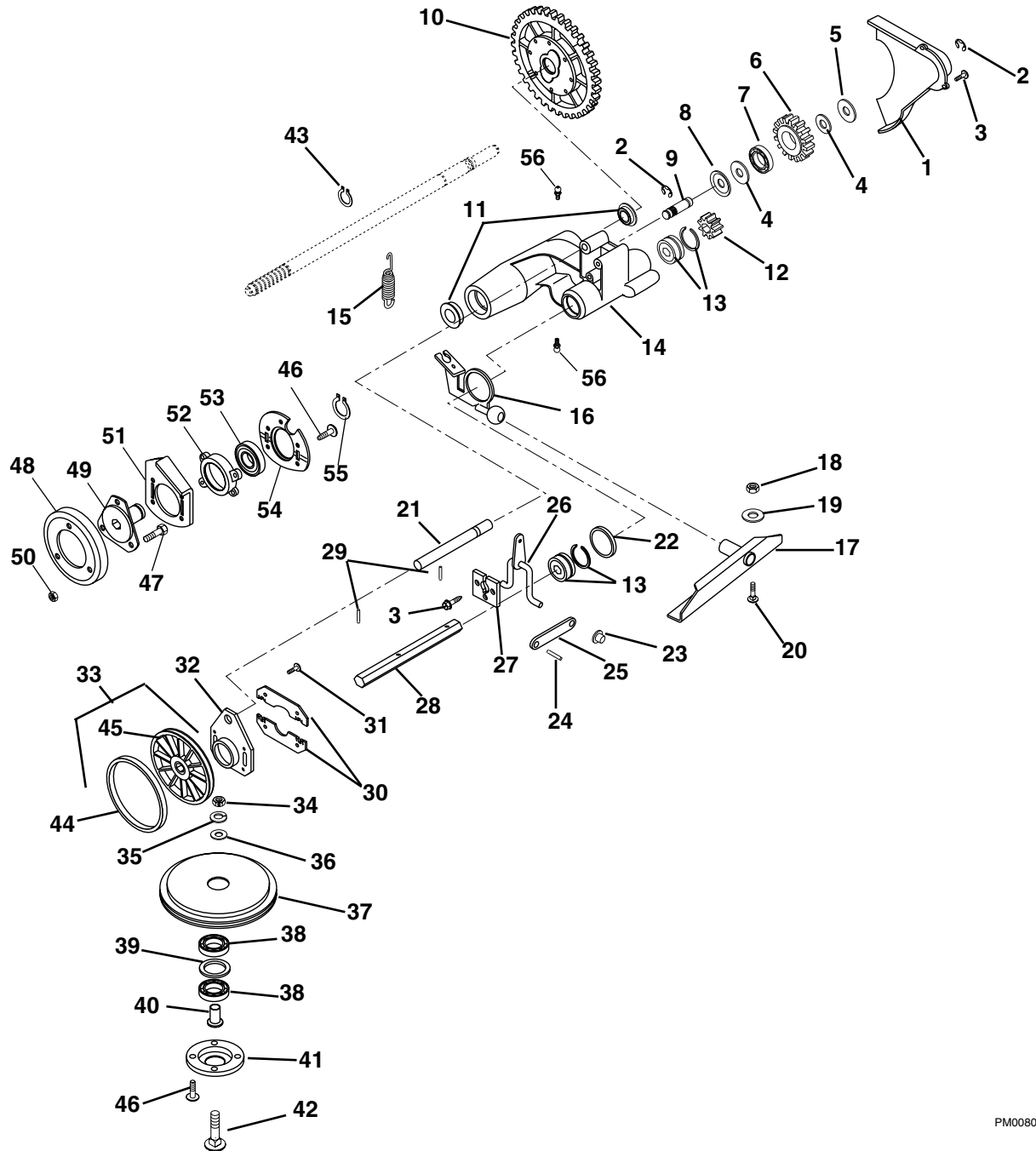

PM0080

Item	Part No.	Qty.	Description
1	606 00 01 59	1	Gear Cover
2	606 00 01 90	2	Ring-Retaining-External .438 x .035
3	606 00 00 92	5	Screw-Tapping 12-24 x .50 Hex Washer Head
4	606 00 01 32	2	Washer - Flat - Steel .520 x .827 x .062
5	606 00 02 01	1	Washer - Flat - Steel .531 x 1.00 x .063
6	606 00 01 68	1	Idler Gear
7*	606 00 01 84	1	Bearing - Ball .50 x 1.38 x .437
8	606 00 01 72	1	Retainer
9	606 00 01 74	1	Idler Shaft
10	606 00 02 13	1	Differential Assembly
11*	606 00 01 22	2	Bearing-Ball .625 x 1.383 x .50 (600 C)

FRICTION WHEEL AND DRIVE

Model 580 R, 580 RS, 580 RSE, 580 RSW, 580 BBC, 600 C

Item	Part No.	Qty.	Description
12	606 00 01 81	1	Gear-Pinion
13	606 00 01 85	2	Bearing - Ball .562 x 1.375 x .437 (600 C)
14	606 00 01 75	1	Drive Mount
15	606 00 02 12	1	Spring-Tension .051 x .60 x 2.25
16	606 00 01 73	1	Drive Actuator Weldment
17	606 00 01 80	1	Pivot Channel Weldment
18	606 00 00 50	2	Nut-Locking-Center .31-18
19	606 00 00 45	2	Washer-Flat-Steel .344 x .688 x .065
20	606 00 01 27	2	Bolt-Round Head Square Short Neck .31-18 x .62
21	606 00 01 63	1	Rod-Guide
22	606 00 01 98	1	Washer - Flat - Steel 1.390 x 2.00 x .020
23	606 00 00 78	2	Push Nut .25
24	606 00 01 93	2	Pin-Roll .125 x .50 (580 R, 580 RS, 580 RSE, 580 RSW, 580 BBC)
	606 00 01 94	2	Pin-Roll .125 x .63 ((600 C)
25	606 00 01 61	2	Shift Link
26	606 00 01 60	1	Shift Arm Weldment
27	606 00 01 62	1	Retainer Plate
28	606 00 01 64	1	Hex Shaft
29	606 00 01 92	2	Pin - Roll .188 x .88
30	606 00 01 77	2	Thrust Plate (580 R, 580 RS, 580 RSE, 580 RSW, 580 BBC)
31	606 00 02 11	4	Screw-Tapping 10-24 x .375 Hex Washer Head (580 R, 580 RS, 580 RSE, 580 RSW, 580 BBC)
32	606 00 01 78	1	Guide-Plate (580 R, 580 RS, 580 RSE, 580 RSW, 580 BBC)
33	606 00 02 14	1	Friction Wheel Assembly (580 R, 580 RS, 580 RSE, 580 RSW, 580 BBC)
34	606 00 02 05	1	Nut-Hex .31-18
35	606 00 01 99	1	Washer-Locking .312 x .097 Heavy
36	606 00 02 03	1	Washer Flat-Steel .328 x .875 x .062
37	606 00 01 65	1	Friction Sheave
38	606 00 01 88	2	Bearing-Ball .625 x 1.375 x .43
39	606 00 02 00	1	Washer- Flat-Steel 1.062 x 1.344 x .032
40	606 00 01 66	1	Spindle, Bearing
41	606 00 01 67	1	Bearing, Retainer
42	606 00 01 97	1	Bolt-Round Head Square Neck .31-18 x 1.75 Grade 5 (600 C)
43	606 00 01 89	2	Ring-Retaining-External .579 x .930
44	606 00 01 79	1	Friction Ring (580 R, 580 RS, 580 RSE, 580 RSW, 580 BBC)
45	606 00 01 76	1	Friction Wheel Hub (580 R, 580 RS, 580 RSE, 580 RSW, 580 BBC)
46	606 00 00 92	4	Screw-Tapping 12-24 x .50 Hex Washer Head (580 R, 580 RS, 580 RSE, 580 RSW, 580 BBC)
	606 00 00 92	8	Screw-Tapping 12-24 x .50 Hex Washer Head (600 C)
47	606 00 01 95	3	Bolt-Hex .25-20 x .50 Grade 5 (600 C)
48	606 00 01 82	1	Disc, Friction (600 C)
49	606 00 01 71	1	Hub, Friction Wheel (600 C)
50	606 00 00 49	3	Nut-Locking-Center .25-20 (600 C)
51	606 00 01 70	1	Bearing Plate (600 C)
52	606 00 01 69	1	Bearing Retainer (600 C)
53	606 00 01 86	1	Bearing Ball 1.00 x 2.00 x .56 (600 C)
54	606 00 01 58	1	Bearing Retainer (600 C)
55	606 00 01 91	1	Ring-Retaining - External 1.00 x .042 (600 C)
56	606 00 01 57	2	Fitting-Lube .25-28 x .256 ((600 C)

* Available as individual components or part of 606 00 02 71 Service Kit which consists of (2) 606 00 01 88, (1) 606 00 01 84 , (2) 606 00 01 85 and (2) 606 00 01 22.

ELECTRICAL AND CONTINUITY DIAGRAM

Model 580 BBC

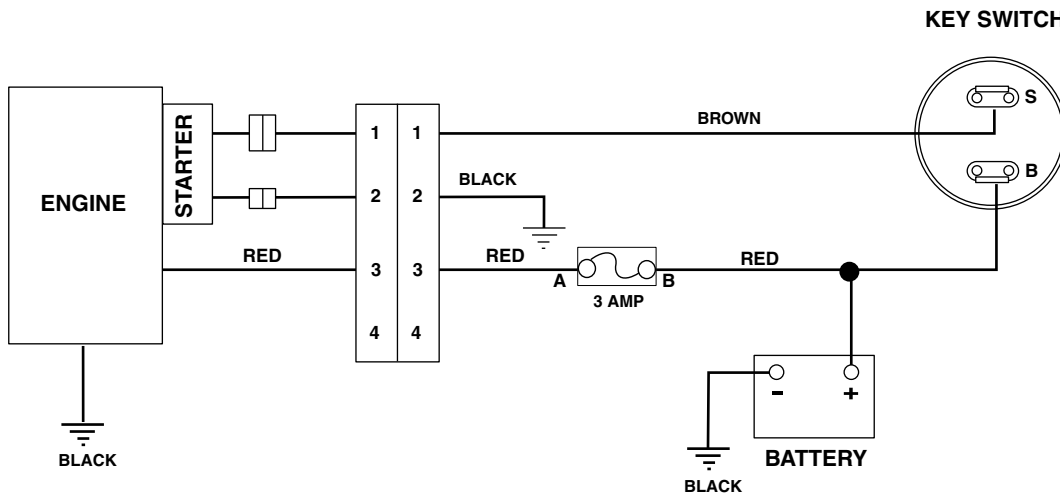

PM0470

The diagram below shows the various states of connection for electrical components. The solid lines on switches show continuity.

NOTE: All switches are viewed from the rear.

Key Switch (606000320)

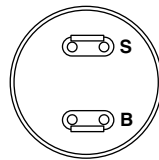

OFF POSITION

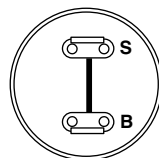

START POSITION

PM0480

For Husqvarna Parts Call 606-678-9623 or 606-561-4983

01192500A

www.mymowerparts.com