



RIGHT FRONT ANTI-SCALP ROLLER FOR: **ZT STANDARD FRAME**

INSTALLATION INSTRUCTIONS FOR:

KIT PART NO.- 539105170

Mower Models - **ZTH 4817A** - 968999151 & **ZTH 4819A** - 968999152

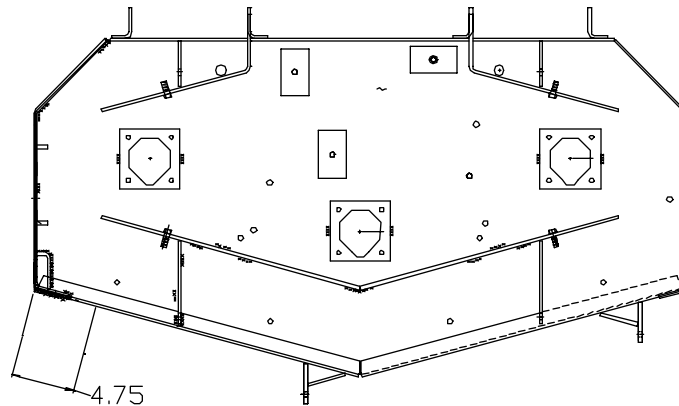

MEASURE RIGHT FRONT CORNER OF DECK FROM EDGE INWARD 4.75 INCHES AND MARK A STRAIGHT LINE AT THAT POINT. (SEE ILLUSTRATION ABOVE.)
MEASURE DOWN FROM THE TOP OF THE DECK 1.56 AND THEN 3.06 INCHES. MARK AND CENTER PUNCH FOR TWO HOLES.
DRILL TWO HOLES .390 DIAMETER FOR MOUNTING THE BRACKET. THE HOLES GO THROUGH THE INNER BAFFLE.

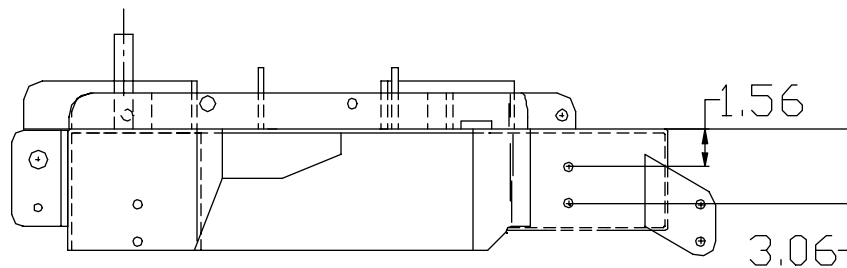

SIDE VIEW

P/N 539105176

REV. 02

06-07-00

BOLT THE ANTI-SCALP ROLLER BRACKET TO THE DECK MAKING SURE TO PUT THE BOLTS FROM THE INSIDE OUT SO GRASS FLOW WILL NOT BE INTERRUPTED. MOUNT THE ROLLER AS SHOWN, KEEPING IN MIND THAT ALL THE ANTI-SCALP ROLLERS SHOULD BE IN THE SAME HOLE FROM THE GROUND.

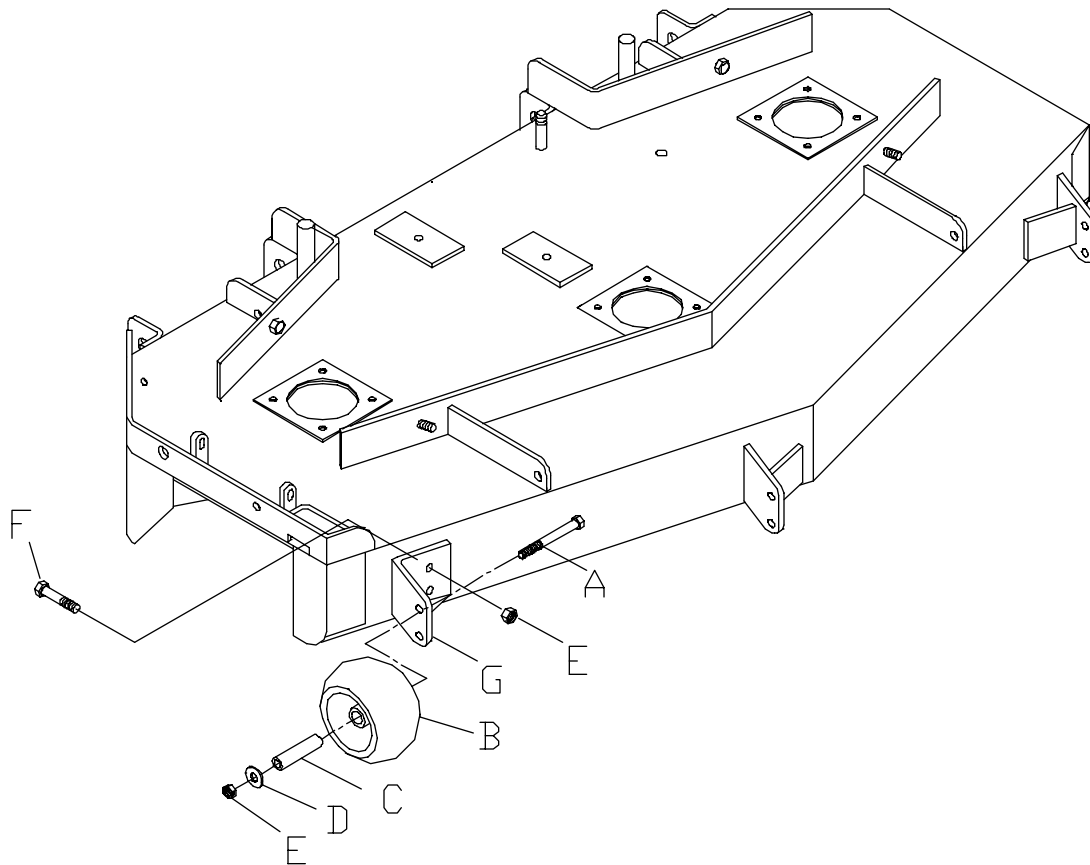

PARTS LIST

ITEM	PART NO.	QTY.	DESCRIPTION
A	539 10 27-54	1	HCS 3/8C X 3-1/2
B	539 10 51-74	1	ANTI-SCALP ROLLER
C	539 10 26-43	1	BUSHING
D	539 99 05-17	1	FW 3/8 STD.
E	539 99 05-46	3	NUT 3/8C CENTERLOCK
F	539 99 06-55	2	HCS 3/8C X 1-1/2
G	539 10 51-71	1	MOUNTING BRACKET