

No  
Diagram  
Available  
  
Parts List  
Only

UT100550 18in. 45cc Chain Saw  
Accessories

Page 2 of 16

Ref #	Part Number	Qty	S/P/F	Description
	631055001	1	S	WRENCH - COMBINATION
	518061001	1		SCABBARD
	308091012	1	S	CARRYING CASE
	983000420	1		OPERATOR'S MANUAL

## CARBURETOR – AIR FILTER

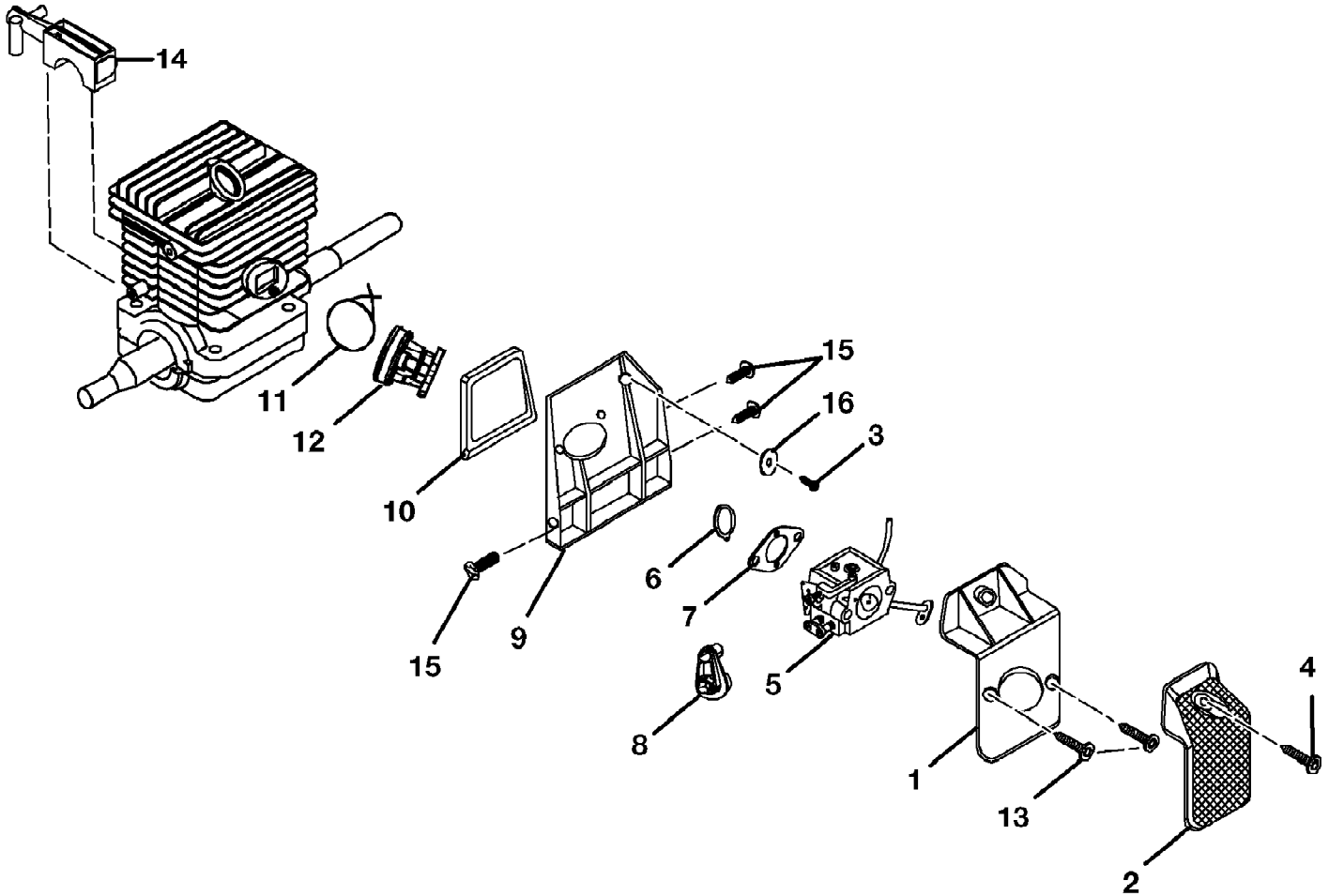

ITEM NO.	TORQUE SPECS.		REQUIRED LOCTITE
	in./lbs.	nm	
4	50-60	5.6-6.7	
13	30-40	3.4-4.5	
15	15-20	1.7-2.3	
17	15-20	1.7-2.3	

UT100550 18in. 45cc Chain Saw  
Carburetor - Air Filter

Page 4 of 16

Ref #	Part Number	Qty	S/P/F	Description
1	518048001	1	S	AIR FILTER BASE
2	518049001	1	S	AIR FILTER COVER
3	660634001	1	/P	SCREW
4	660617001	1	S	SCREW (8-16 x 5/8 in.)
5	308070001	1	S	CARBURETOR
6	518045001	1	S	PLATE, CARBURETOR
7	900886001	1	S	GASKET, CARBURETOR
8	570242001	1	S	GROMMET, CARBURETOR
9	308081001	1		ADAPTOR, CARBURETOR
10	518047001	1	S	SEAL-CARB. ADAPTOR
11	671267001	1	S	CLAMP
12	570243001	1	S	INTAKE BOOT
13	660655001	2		SCREW (10-32 x 1.75 mm)
14	300945002	1		OIL PUMP ASSEMBLY
15	660629001	3	S	SCREW (TORX)
16	671072001	1	S	WASHER

## CLUTCH – CHAIN BRAKE – DRIVE CASE COVER

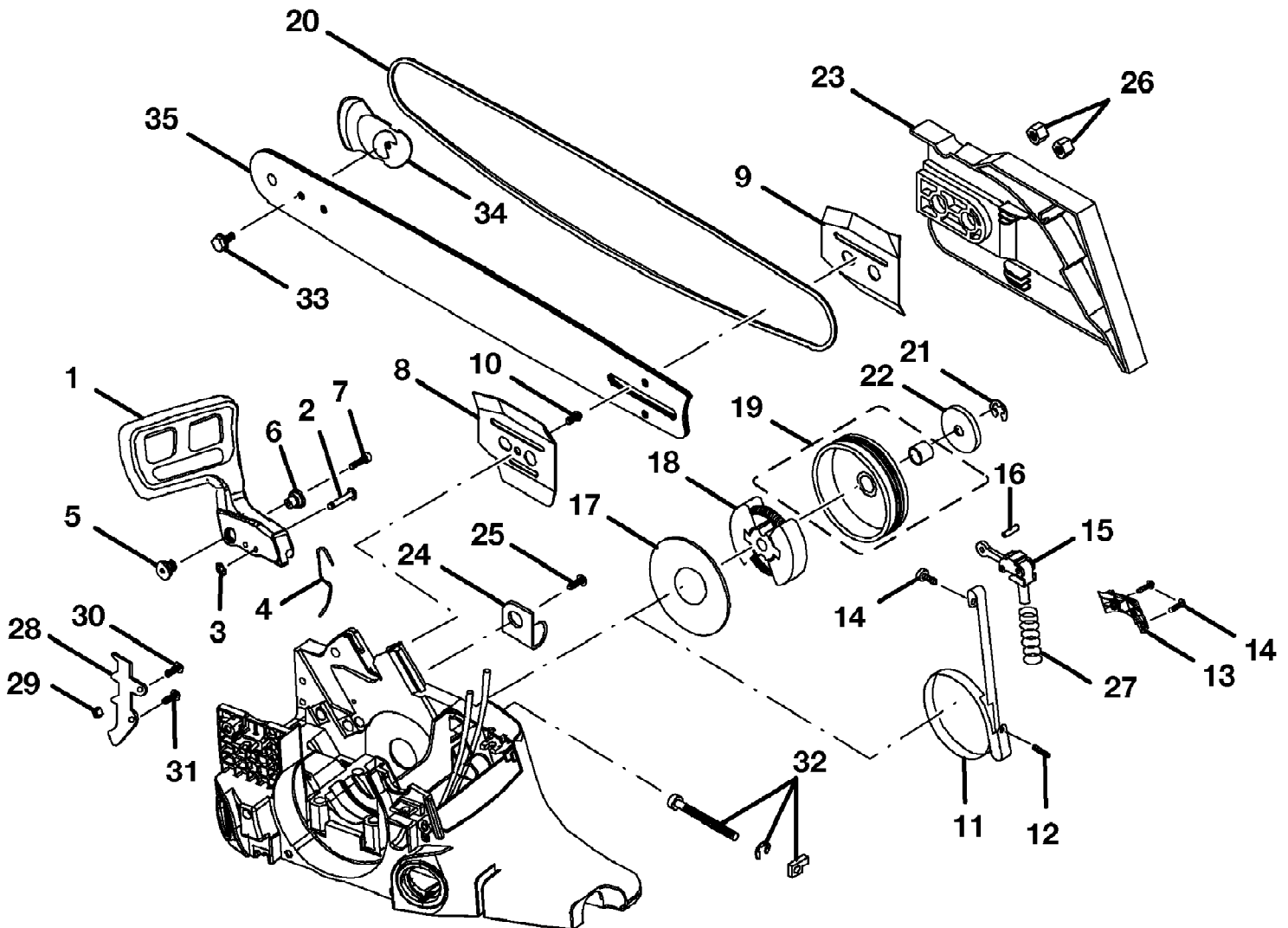

ITEM NO.	TORQUE SPECS.		REQUIRED LOCTITE
	in./lbs.	nm	
7	25-35	2.8-3.9	242 BLUE
10	8-18	0.9-2.0	
14	20-30	2.3-3.4	
18	130-180	14.7-20.3	
25	30-50	3.4-5.6	
26	HAND TIGHT		

UT100550 18in. 45cc Chain Saw  
Clutch - Chain Brake - Drive Case Cover

Page 6 of 16

Ref #	Part Number	Qty	S/P/F	Description
1	511723001	1	/P	HAND GUARD
2	620282001	1	/P	HAND GUARD ACTUATING PIN
3	671075001	1	S	RETAINING RING
4	638024001	1	/P	SPRING, HANDGUARD
5	671097001	1	/P	PIVOT, LH
6	671096001	1	/P	PIVOT, RH
7	660635001	1	S	SCREW (8-32 x 5/8 in.)
8	631036001	1	S	PLATE, GUIDE BAR
9	631038001	1	S/P	PLATE, GUIDE BAR
10	T660619001	1		SCREW (6-19 x 1/2 in.)
11	631063001	1	S	BRAKE BAND
12	671095001	1	/P	PIN, ROLL
13	511720001	1	S	BRAKE BAND COVER
14	660634001	3	/P	SCREW (8-16 x .320 )
15	300954001	1	S	CHAIN BRAKE LINK
16	671099001	1	S	PIN, ROLL
17	631061001	1	S	THRUST WASHER
18	300960001	1	S/P	CLUTCH & HARDWARE
19	300958002	1		SPROKET DRUM & BEARING ASSEMBLY (.325 PITCH)
20	900920004	1	S	CHAIN
21	671103001	1	S	RING, RETAINING
22	631060001	1	S	WASHER
23	300957001	1	/P	DRIVE CASE COVER
24	631035001	1	S	CHAIN CATCHER
25	660618001	1	S	SCREW (10-24 x 1/2 in.)
26	671076001	2	/P	NUT, HEX
27	678113001	1	S	SPRING, COMPRESSION
28	631039001	1	S	BUMPER SPIKE
29	678027002	1	S	LOCK NUT, HEX (10-24)
30	660625001	1	S	SCREW
31	660621001	1	S	SCREW, TRUSS HD.
32	308116001	1	/P	ADJUSTING PIN KIT
33	660640001	1		SCREW - SAFETY TIP (HEX HD.)
34	308006003	1		SAFETY TIP
35	308108001	1		GUIDE BAR

# ENGINE HOUSING – FUEL TANK – OIL TANK

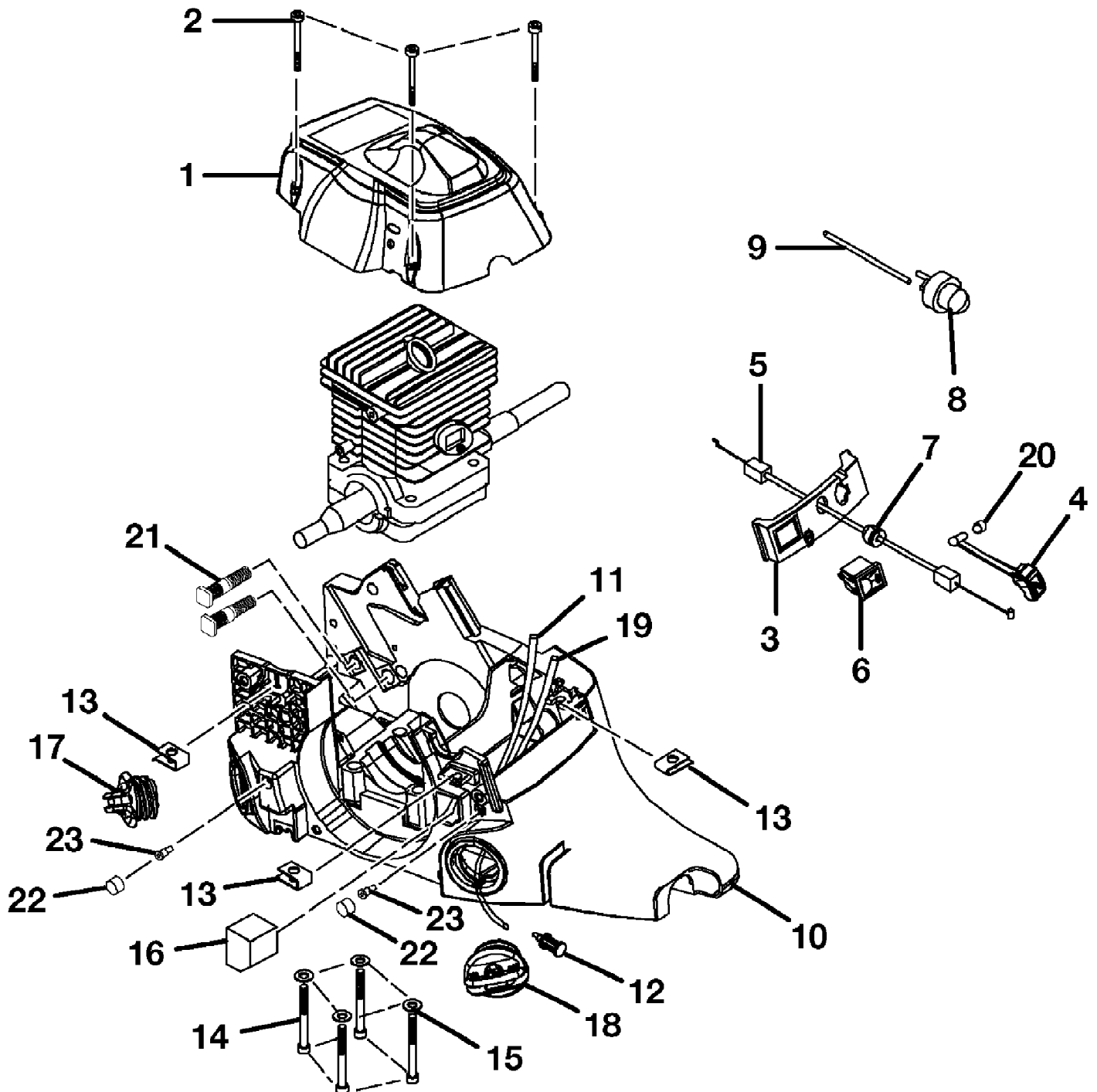

ITEM NO.	TORQUE SPECS.		REQUIRED LOCTITE
	in./lbs.	nm	
2 . . . . .	15-25 . . . . .	1.7-2.3	
14 . . . . .	65-75 . . . . .	7.3-8.5 . . . . .	262 RED

UT100550 18in. 45cc Chain Saw  
 Engine Housing - Fuel Tank - Oil Tank

Page 8 of 16

Ref #	Part Number	Qty	S/P/F	Description
1	518042001	1	S/P	CYLINDER COVER
2	660636001	3	/P	SCREW (10-16 X 1.5 PAN HD.)
3	518044001	1	S	CONTROL PANEL
4	511709002	1	S	ROD, CHOKE
5	900885001	1	/P	THROTTLE CABLE
6	760352001	1	S	SWITCH, ROCKER
7	570227001	2	S	GROMMET - SPLIT
8	308088001	1	/P	PRIMER BULB
9	570247004	1	S	RUBBER TUBING (2-1/2 in.)
10	300947003	1		CHASSIS & COMPONENTS ASSEMBLY (45CC)
11	570247003	1	S	RUBBER TUBING (8-1/2 in.)
12	300759003	1	S	FUEL FILTER
13	671077001	3	S	SPEED NUT
14	660622001	4	/P	SCREW (10-24 x 2 in.)
15	671080001	4	/P	WASHER
16	900844001	1	S	PRE FILTER
17	300949001	1	/P	OIL CAP
18	300948001	1	/P	FUEL CAP
19	570247002	1	S	RUBBER TUBING (5-1/2 in.)
20	631034002	1		HAIR PIN, CHOKE ROD
21	660628001	2	S	BOLT, GUIDE BAR
22	671088001	2	/P	ELEMENT, BRONZE
23	560955001	2	/P	DUCK BILL VALVE
	940299388	1		STARTING INSTRUCTION
	940299512	1		CHAIN BRAKE
	940299376	1		KICKBACK
	940299381	1		DRIVECASE COVER
	940299373	1		STARTER HOUSING
		1		DECALS: 18 in. (45cc)
	940299384	1		GUIDE BAR OIL LABEL
	940299383	1		FUEL MIX LABEL (50:1)



# ENGINE INTERNAL - OIL PUMP

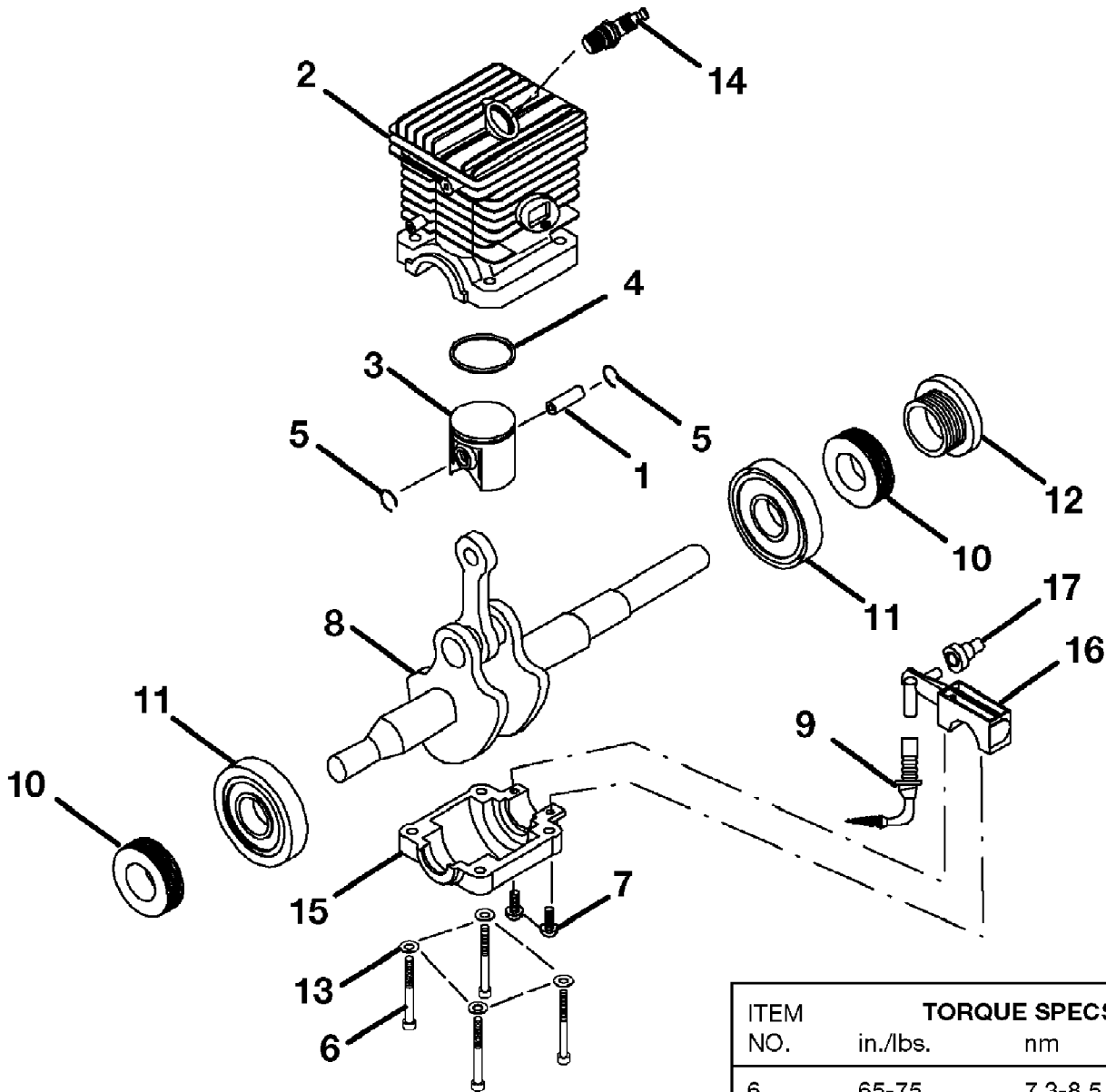

ITEM NO.	TORQUE SPECS.		REQUIRED LOCTITE
	in./lbs.	nm	
6	65-75	7.3-8.5	262 RED
7	15-20	1.7-2.3	
14	120-180	13.6-20.3	

UT100550 18in. 45cc Chain Saw  
 Engine Internal - Oil Pump

Page 10 of 16

Ref #	Part Number	Qty	S/P/F	Description
	300982004	1		SHORT BLOCK ASSEMBLY
1	620295001	1	S	PISTON PIN
2	640840001	1	S	CYLINDER MACH/PLATED
3	640839001	1	S	45CC PISTON (MACH)
4	678036001	1		PISTON RING
5	671082001	2	S	RETAINING RING
6	660622001	4	/P	SCREW TORX PLUS CAP-SOCKET HD
7	660627001	2	S	SCREW, (8/32 X 5/8 in. PAN HD TORX)
8	308068001	1		45CC SINTERED METAL CRANKSHAFT ASSEMBLY
9	300950001	1	S	OIL INTAKE TUBE W/FILTER
10	570220001	2	/P	SHAFT SEAL
11	308007001	2		BEARING CASE ASSEMBLY
12	T610389001	1	/P	LEFT HAND WORM
13	671080001	4	/P	FLAT WASHER
14	870170001	1		SPARK PLUG
15	640843001	1	S	CRANKCASE (45CC) CS
16	300945002	1		OIL PUMP ASSEMBLY
17	570226001	1	S	GROMMET, OIL OUTLET

## HANDLES

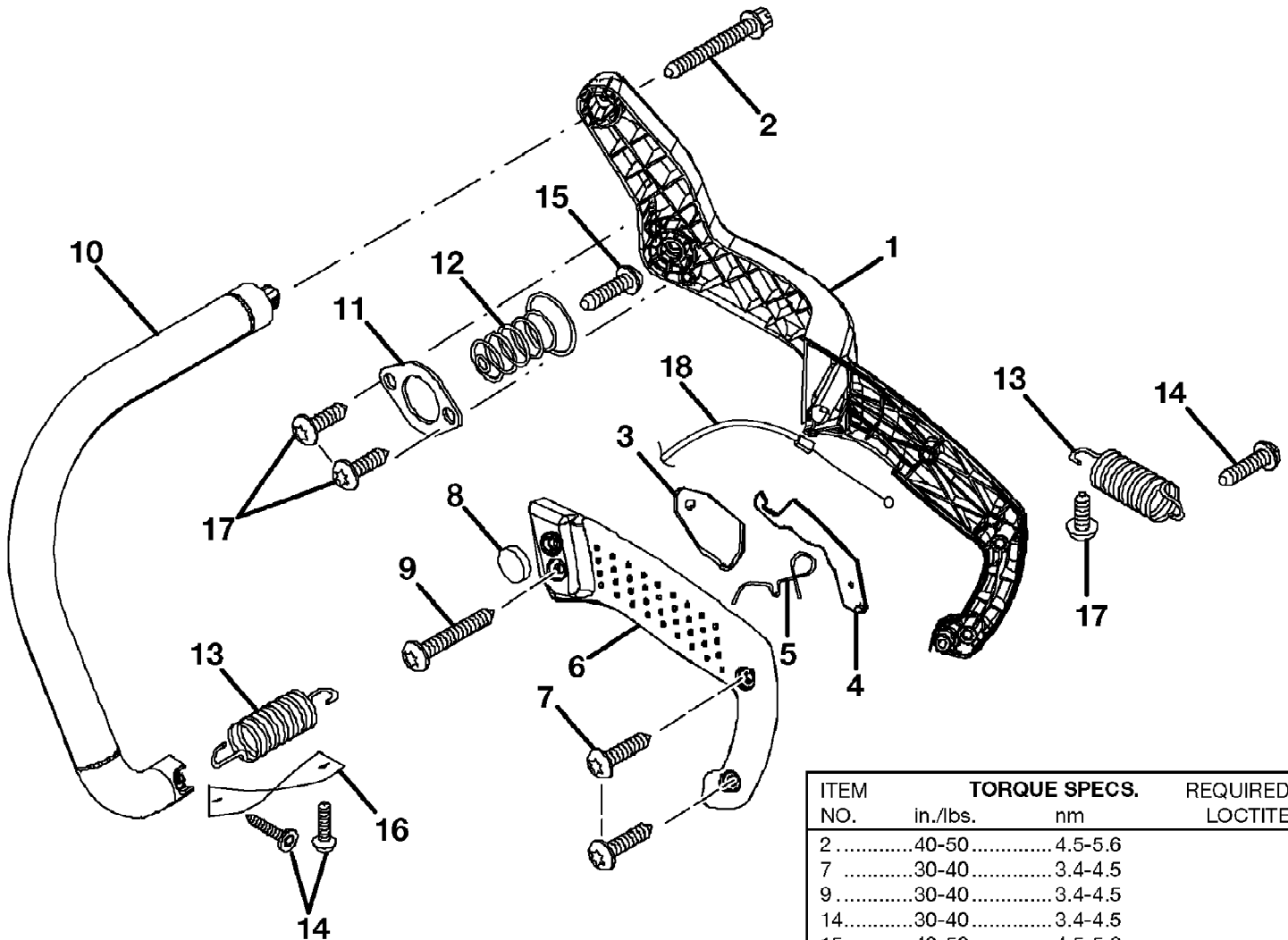

ITEM NO.	TORQUE SPECS.		REQUIRED LOCTITE
	in./lbs.	nm	
2	40-50	4.5-5.6	
7	30-40	3.4-4.5	
9	30-40	3.4-4.5	
14	30-40	3.4-4.5	
15	40-50	4.5-5.6	
17	30-40	3.4-4.5	

UT100550 18in. 45cc Chain Saw  
Handles

Page 12 of 16

Ref #	Part Number	Qty	S/P/F	Description
1	511721001	1	/P	REAR HANDLE
2	660631001	1	S	SCREW (12-14 x 1-1/2 in.)
3	518052001	1	/P	TRIGGER, THROTTLE
4	518051001	1	S	THROTTLE LOCK OUT
5	678037001	1	S	TORSION SPRING
6	511722001	1	S	HANDLE COVER
7	660629001	2	S	SCREW (10-14 x 3/4 in.)
8	518050001	1	S	PLUG-PLASTIC
9	660633001	1	S	SCREW (10-14 x 1-3/8 in.)
10	511724001	1	S	FRONT HANDLE
11	631051001	1		ISOLATOR PLATE
12	671098001	1	S	UPPER ISOLATION SPRING
13	671101001	2	S	SPRING- ISOLATOR
14	660632001	3	S	SCREW (10-14 x 5/8 in.)
15	660630001	1	/P	SCREW (10-24 x 5/8 in.)
16	631050001	1	S	SPRING RETAINER
17	660618001	3	S	SCREW (10-14 x 1/2 in.)
18	900885001	1	/P	THROTTLE CABLE

# MUFFLER

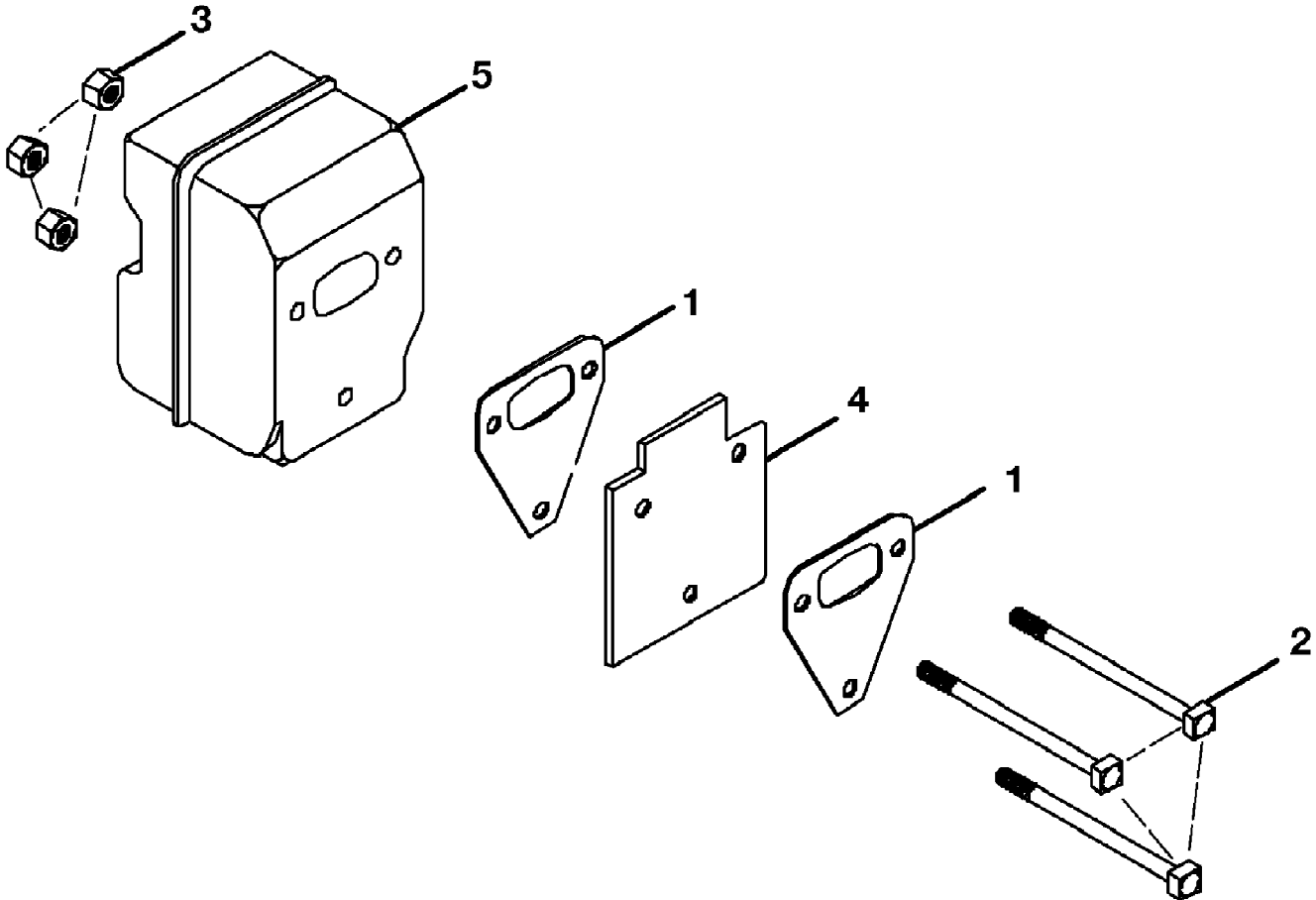

ITEM NO.	TORQUE SPECS.		REQUIRED LOCTITE
	in./lbs.	nm	
3	50-60	5.6-6.7	

UT100550 18in. 45cc Chain Saw  
Muffler

Page 14 of 16

Ref #	Part Number	Qty	S/P/F	Description
1	900848002	2		MUFFLER GASKET
2	660626001	3	/P	SCREW-SQUARE HD.
3	671079001	3	/P	NUT-LOCKING HEX (10-32)
4	900888002	1	S	MUFFLER PLATE
5	308071001	1	S	MUFFLER ASSEMBLY

# STARTER - IGNITION

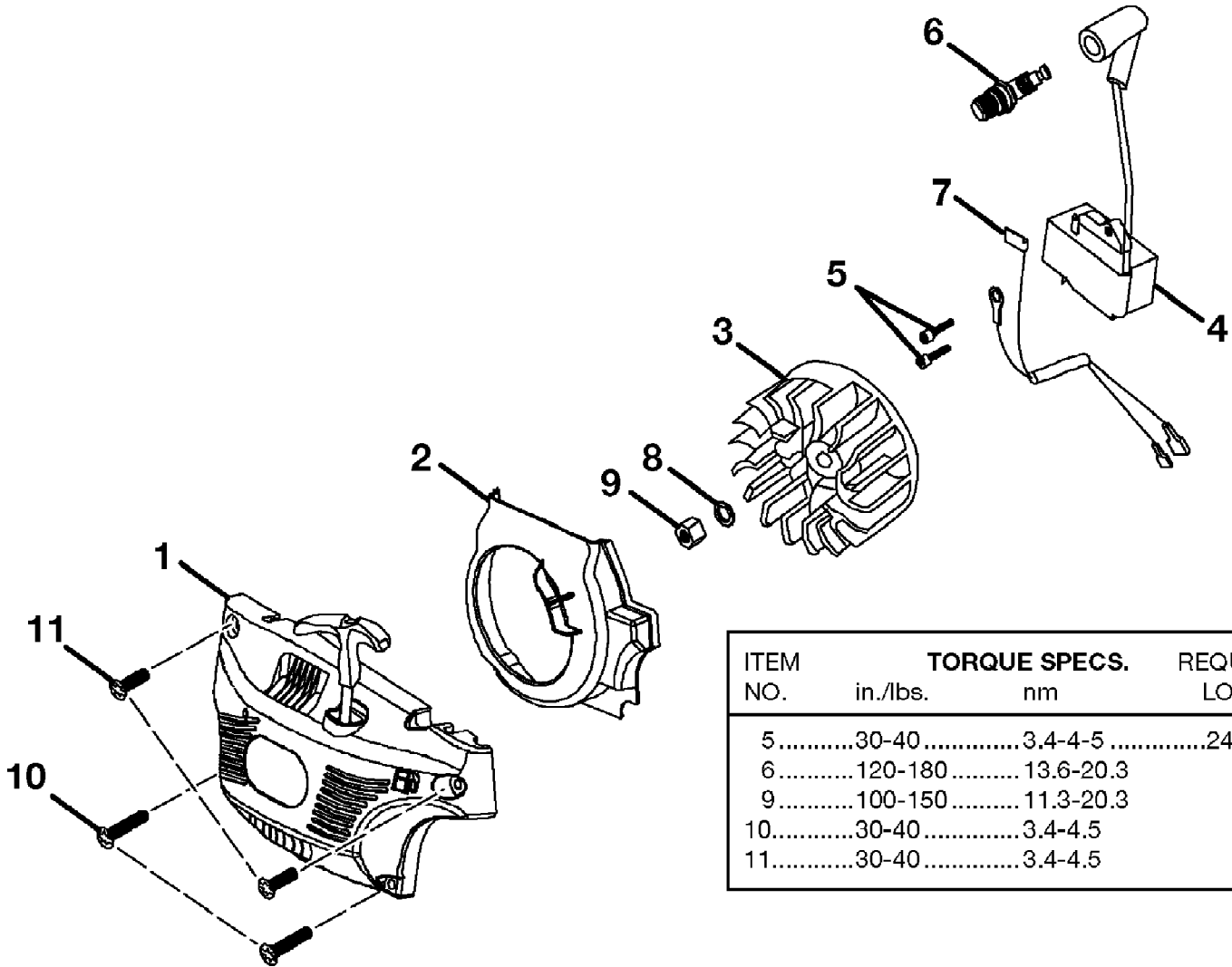

ITEM NO.	TORQUE SPECS.		REQUIRED LOCTITE
	in./lbs.	nm	
5	30-40	3.4-4.5	242 blue
6	120-180	13.6-20.3	
9	100-150	11.3-20.3	
10	30-40	3.4-4.5	
11	30-40	3.4-4.5	

UT100550 18in. 45cc Chain Saw  
Starter - Ignition

Page 16 of 16

Ref #	Part Number	Qty	S/P/F	Description
1	300982012	1	/P	STARTER COVER ASSY., W/EYELET
2	518055001	1	S	BAFFLE
3	308084001	1		ROTOR W/STARTER PAWL
4	300953001	1	S	IGNITION KIT
5	660639001	2	/P	SCREW (8-32 x 5/8 in.)
6	870170001	1		SPARK PLUG
7	290195003	2	/P	IGNITION SWITCH HARNESS
8	631049001	3	S/P	WASHER
9	678123001	4	/P	NUT
10	660637001	5	S	SCREW (10-14 x 7/8 in.)
11	660632001	6	S	SCREW (10-14 x 5/8 in.)