

8800HG Chain Saw UT-10810
Carburetor - Air Cleaner

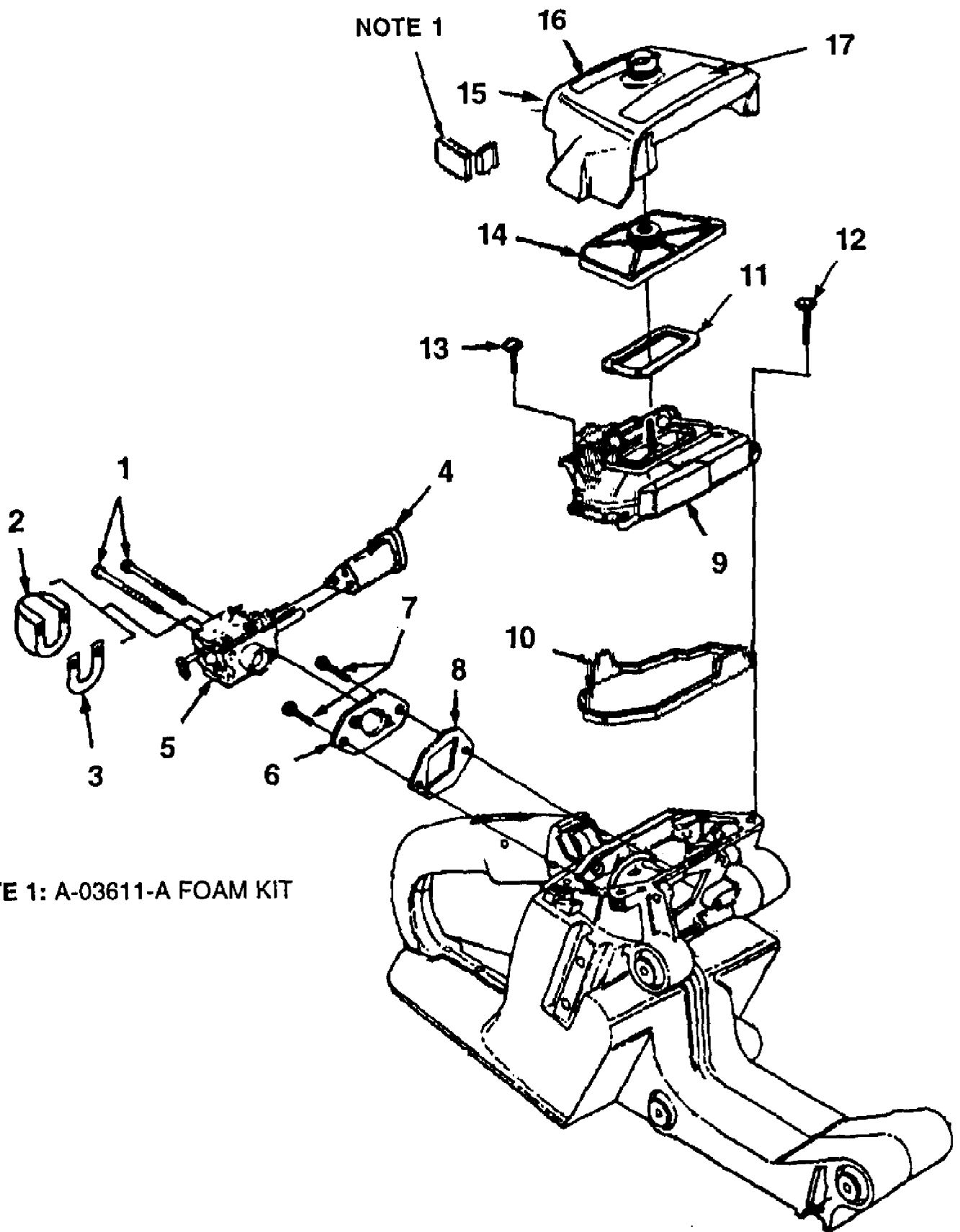

8800HG Chain Saw UT-10810
Carburetor - Air Cleaner

Page 2 of 12

| Ref # | Part Number | Qty | S/P/F | Description |
|-------|-------------|-----|-------|---|
| 1 | 82527 | 2 | S/P | SCREW - Hex Cap (10-24 X 2") Torque Spec. 40 - 50 In/Lbs, 4.5 - 5.6 Nm; 262 Red Loctite Required |
| 2 | 49673 | 1 | | SHIELD - Carburetor |
| 3 | 49671 | 1 | /P | GASKET - Carburetor Shield |
| 4 | PS97295 | 2 | /P | GROMMET |
| 5 | A07571 | 1 | /P | CARBURETOR KIT |
| 6 | 972902A | 1 | S | ADAPTER - Carburetor |
| 7 | 96620 | 2 | /P | SCREW - Torx Truss (10-24 X 1/2") Torque Spec. 50 - 60 In/Lbs, 5.6 - 6.8 Nm; 262 Red Loctite Required |
| 8 | PS97291 | 1 | /P | GASKET - Carburetor |
| 9 | A97296 | 1 | /P | COVER - Carburetor Chamber |
| 10 | PS97298 | 1 | S | GASKET - Carburetor Chamber |
| 11 | 04635 | 1 | /P | GASKET - Air Filter |
| 12 | 80582 | 2 | | SCREW - Pan Hd. (8-32 X 5/8") Torque Spec. 15 - 20 In/Lbs, 1.7 - 2.8 Nm; 242 Blue Loctite Required |
| 13 | 80577 | 2 | | SCREW - Machine Pan Hd. (8-32 x 3/8") Torque Spec. 15 - 20 In/Lbs, 1.7 - 2.8 Nm |
| 14 | A97303B | 1 | | ELEMENT - Filter |
| 15 | A04636A | 1 | /P | COVER - Air Filter |
| 16 | 00780 | 1 | | DECAL - Warning |
| 17 | 96731A | 1 | S | DECAL - Warning |

8800HG Chain Saw UT-10810
Clutch - Oil Pump

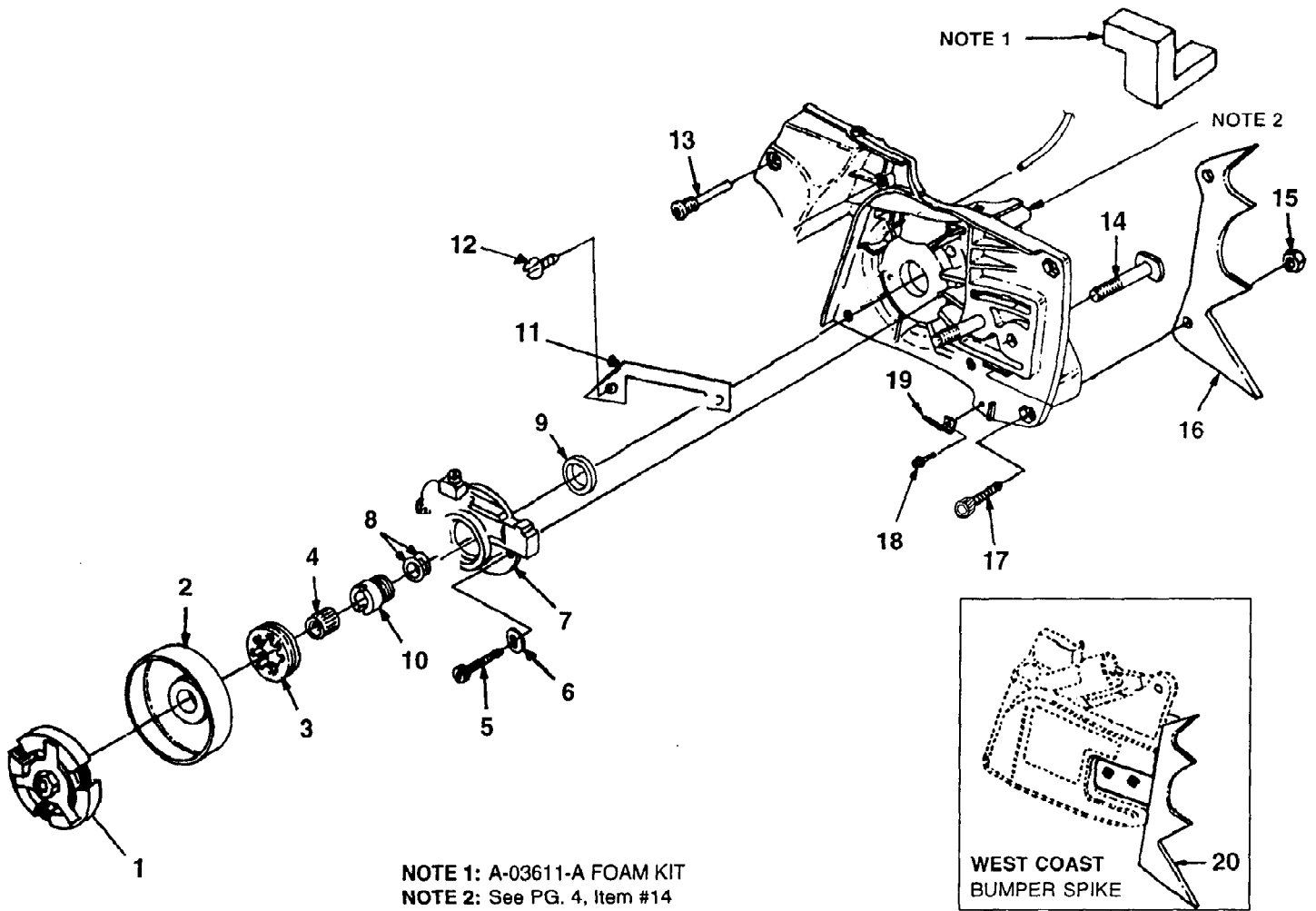

8800HG Chain Saw UT-10810
Clutch - Oil Pump

Page 4 of 12

| Ref # | Part Number | Qty | S/P/F | Description |
|-------|-------------|-----|-------|---|
| 1 | A00022A | 1 | S | CLUTCH |
| 2 | A003511 | 1 | | DRUM & HUB |
| 3 | 95058A | 1 | | SPROCKET (7T X 3/8P) |
| | 63285A | 1 | | SPROCKET (7T X .404) |
| 4 | 98883 | 1 | | BEARING - Needle |
| 5 | 82562 | 2 | S | SCREW - Cap Socket Hd. (10-24 X 7/8") Torque Spec. 20 - 25 In/Lbs, 2.3 - 2.8 Nm; 262 Red Loctite Required |
| 6 | 84003 | 2 | /P | WASHER - Flat (010) |
| 7 | A04891 | 1 | /P | OIL PUMP |
| 8 | 84119 | 1 | | WASHER-Thrust |
| 9 | 58308B | 1 | S | SEAL - Shaft |
| 10 | A00357A | 1 | /P | WORM & BEARING |
| 11 | 04621 | 1 | | SHIELD - Pump |
| 12 | 80575 | 2 | | SCREW - Slotted Hd. (8-32 X 1/4") Torque Spec. 30 - 40 In/Lbs, 3.4 - 4.5 Nm; 242 Blue Loctite Required |
| 13 | 93367 | 6 | | PIN - Isolator Torque Spec. 60 - 70 In/Lbs, 6.8 - 7.9 Nm |
| 14 | 93918A | 2 | S | BOLT - Guide Bar (3/8-16 X 2") |
| 15 | 81225 | 2 | /P | NUT - Hex (#12-24) |
| 16 | 01233 | 1 | /P | BUMPER SPIKE |
| 17 | 82572 | 2 | /P | SCREW - Socket Cap (12-24 X 5/8") Hand Tight |
| 18 | 96620 | 1 | /P | SCREW - Torx Hd. (10-24 X 1/2") Torque Spec. 50 - 60 In/Lbs, 5.6 - 6.8 Nm |
| 19 | 04626 | 1 | | CHAIN - Stop |
| 20 | A98969A | 1 | | BUMPER SPIKE (West Coast) |

8800HG Chain Saw UT-10810
Engine Housing

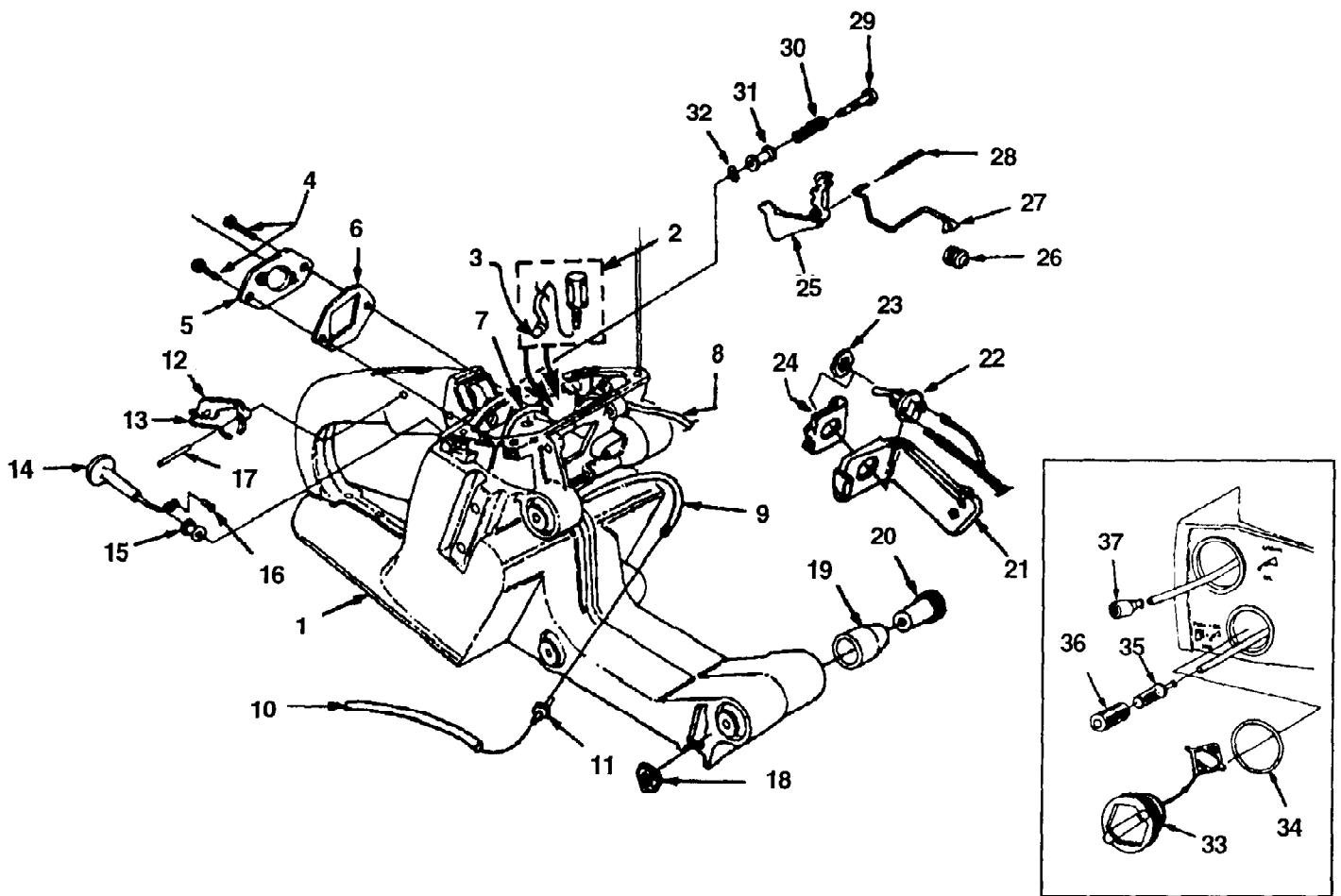

8800HG Chain Saw UT-10810
Engine Housing

Page 6 of 12

| Ref # | Part Number | Qty | S/P/F | Description |
|-------|-------------|-----|-------|---|
| 1 | A04892A | 1 | /P | HOUSING - Engine |
| 2 | A07012 | 2 | | TANK VENT KIT |
| 3 | 96841 | 1 | S | VALVE - Duck Bill |
| 4 | 96620 | 2 | /P | SCREW - Torx Truss (10-24 X 1/2") Torque Spec. 50 - 60 In/Lbs, 262 Red Loctite Required |
| 5 | 972902A | 1 | S | ADAPTOR - Carburetor |
| 6 | PS97291 | 1 | /P | GASKET - Carburetor |
| 7 | 9311238 | 1 | /P | TUBING - Rubber (Fuel Line, 9 1/2") |
| 8 | 9315720 | 1 | | TUBING - Rubber (Oil Line, 5") |
| 9 | 9311226 | 1 | | TUBING - Rubber (Pulse Line, 6 1/2") |
| 10 | 7045423 | 1 | | TUBING - Rubber (5 3/4") |
| 11 | 02067 | 1 | /P | FITTING - Inline Fuel |
| 12 | 93385A | 1 | /P | TRIGGER - Lock |
| 13 | PS97265 | 1 | /P | SPRING - Flat |
| 14 | 972921 | 1 | S | ROD - Choke |
| 15 | 64862 | 1 | /P | GROMMET |
| 16 | 86324 | 1 | /P | PIN - Cotter |
| 17 | 68548 | 1 | | PIN - Trigger |
| 18 | 81206 | 3 | S/P | Nut - Locking Hex (10-32) |
| 19 | 973052 | 6 | /P | ISOLATOR - Vibration |
| 20 | PS97262 | 6 | S | SLEEVE - Flanged |
| 21 | PS97306A | 1 | S | COVER |
| 22 | A57650A | 1 | /P | SWITCH - Toggle |
| 23 | 72084A1 | 1 | S | NUT - Hex |
| 24 | 12893 | 1 | | PLATE - Indicating |
| 25 | 93842 | 1 | /P | TRIGGER - Throttle |
| 26 | 69889 | 1 | /P | BOOT - Throttle Rod |
| 27 | 97294A | 1 | S | ROD - Throttle |
| 28 | 68548 | 1 | | PIN - Trigger |
| 29 | 95671 | 1 | S | PIN - Throttle Lock |
| 30 | 95020A | 1 | /P | SPRING - Compression |
| 31 | 95989 | 1 | S | BUSHING - Flanged |
| 32 | 58409 | 1 | /P | RING - Retaining |
| 33 | A03131 | 2 | S | CAP - Fuel & Oil |
| 34 | 98805A | 1 | /P | GASKET - Fuel & Oil Cap |
| 35 | A97700 | 1 | S | FILTER - Fuel |
| 36 | 592531A | 1 | /P | ELEMENT - Felt Filter |
| 37 | A68593 | 1 | | OIL FILTER |

8800HG Chain Saw UT-10810
Engine Internal

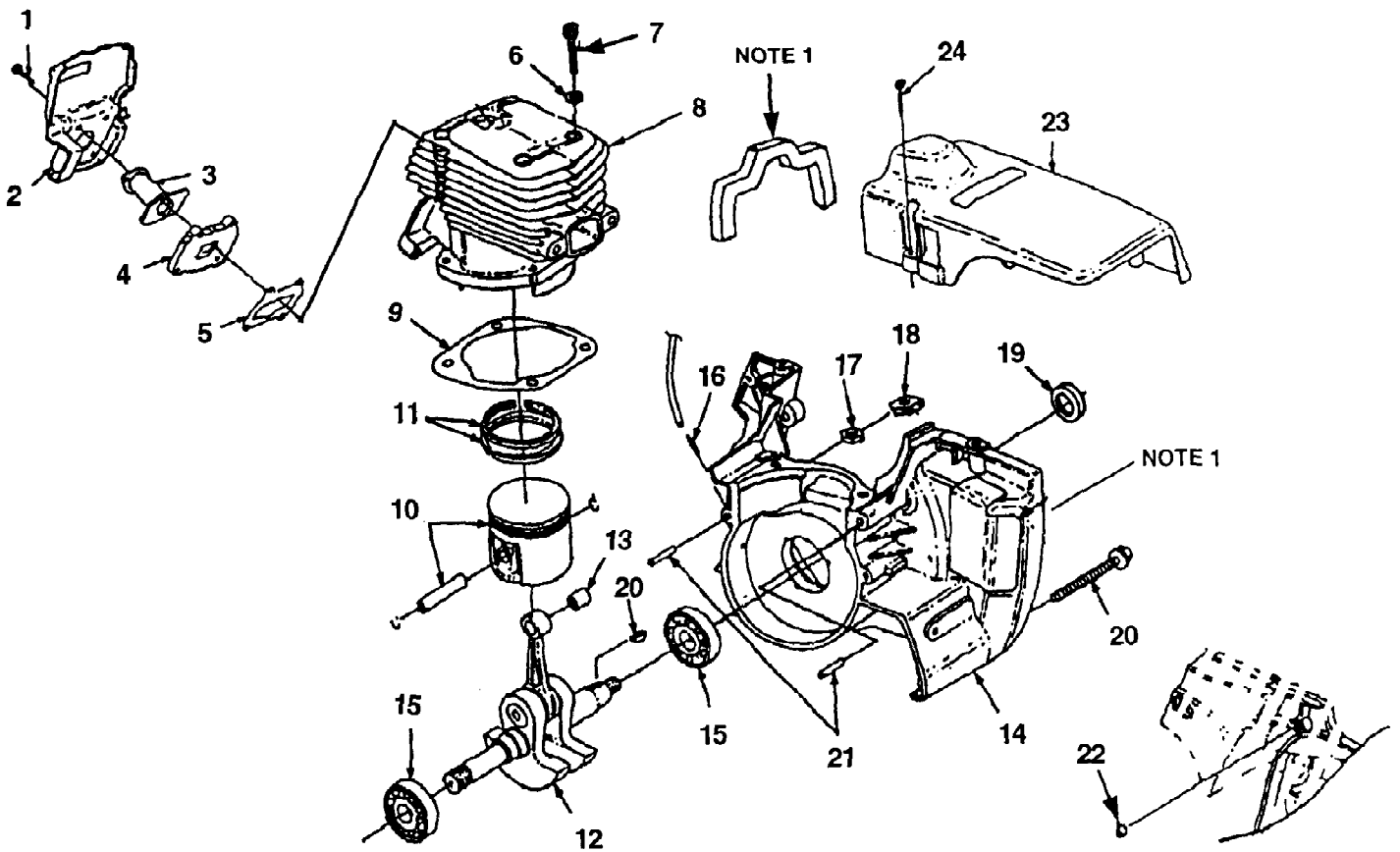

NOTE 1: A-03611-A FOAM KIT

8800HG Chain Saw UT-10810
Engine Internal

Page 8 of 12

| Ref # | Part Number | Qty | S/P/F | Description |
|-------|-------------|-----|-------|--|
| 1 | 82248 | 4 | | SCREW - MACH. HEX HD (8-32 X 3/4") Torque Spec. 15 - 25 In/Lbs, 1.7 - 2.8 Nm; 242 Blue Locktite Required |
| 2 | 973381A | 1 | S | BAFFLE - CYLINDER |
| 3 | 972632 | 1 | /P | BOOT - INTAKE |
| 4 | 02822 | 1 | /P | ADAPTER - INTAKE |
| 5 | 04635 | 1 | /P | GASKET - INTAKE |
| 6 | 12021 | 4 | /P | WASHER - CONICAL (#10) |
| 7 | 82246 | 4 | /P | SCREW - CAP SOCKET (10-24 X 1") Torque Spec. 80 - 90 In/Lbs, 9.0 - 10.2 Nm; 262 Red Locktite Required |
| 8 | A02830A | 1 | /P | CYLINDER & PISTON (MATCHED) |
| 9 | PS97316 | 1 | /P | GASKET - CYLINDER |
| 10 | A028241B | 1 | /P | PISTON & PIN ASSY. |
| 11 | 02825 | 2 | | PISTON RING |
| 12 | A00792A | 1 | /P | CRANKSHAFT & ROD |
| 13 | 93519 | 1 | /P | BEARING - NEEDLE |
| 14 | A07082 | 1 | /P | CRANKCASE ASSY |
| 15 | 94621A | 2 | S | BEARING - BALL |
| 16 | 69833 | 1 | /P | FITTING - TUBE |
| 17 | 81208 | 2 | /P | NUT - LOCK HEX (10-24) |
| 18 | 12689A | 2 | | NUT - RETAINER |
| 19 | 58308B | 1 | S | SEAL - SHAFT |
| 20 | 88057 | 5 | S | SCREW - HEX SEMS (10-24 X 2") Torque Spec. 70 - 80 In/Lbs, 7.9 - 9.0 Nm; 262 Red Locktite Required |
| 21 | PS31062 | 1 | S | PIN - DOWEL |
| 22 | PS97330 | 1 | /P | BUSHING |
| | 93918A | 2 | S | BOLT - GUIDE BAR (SEE CLUTCH PG) |
| 23 | A02121 | 1 | S | COVER - CYLINDER |
| 24 | 93397A | 3 | /P | SCREW - CYLINDER COVER Torque Spec. 20 - 30 In/Lbs, 2.3 - 3.4 Nm |
| | A03611A | 1 | S | FOAM KIT |

8800HG Chain Saw UT-10810
Hand Guard - Handles

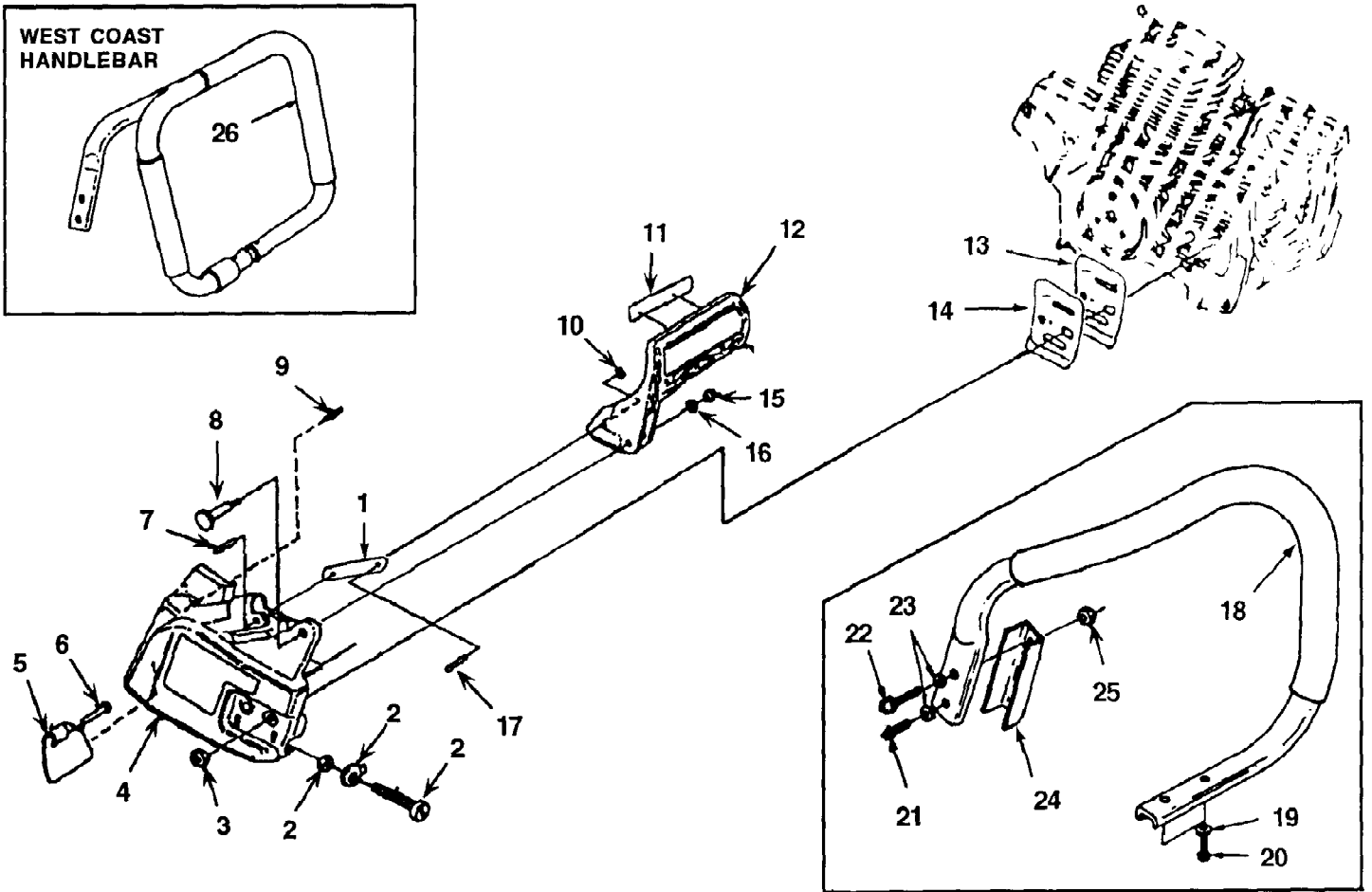
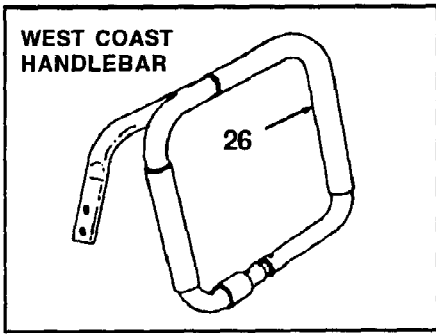

| Ref # | Part Number | Qty | S/P/F | Description |
|-------|-------------|-----|-------|--|
| 1 | PS01153 | 1 | | HAND GUARD LINK |
| 2 | A04889 | 1 | | GUIDE BAR ADJ. KIT |
| 3 | 810892 | 2 | /P | NUT - HEX (10-24) Hand Tight |
| 4 | A98727C | 1 | S | COVER - DRIVE CASE |
| 5 | 04634 | 1 | | SAWDUST SHIELD |
| 6 | 85154 | 1 | S | RIVET - PAN HO (.187 X .381) |
| 7 | 98456 | 1 | | PIN (5M X 16MM) |
| 8 | 98461 | 1 | | SCREW - SHOULDER (M5) Torque Spec. 40 - 50 In/Lbs, 4.5 - 5.6 Nm |
| 9 | PS97331 | 1 | S | PIN - SHOULDER DOWEL |
| 10 | 01820 | 1 | | RING - SNAP |
| 11 | 02661 | 1 | | DECAL - HANDGUARD |
| 12 | 98740 | 1 | | HANDGUARD |
| 13 | 70399 | 1 | S | PLATE - G/BAR (INNER) |
| 14 | 70400 | 1 | S | PLATE - G/BAR (OUTER) |
| 15 | 98457 | 1 | | NUT (5MM) Torque Spec. 40 - 50 In/Lbs, 4.5 - 5.6 Nm |
| 16 | 83203 | 1 | | WASHER - BELLEVILLE (12MM) |
| 17 | 98422A | 1 | | PIN - (.156 DIA) |
| 18 | A04623 | 1 | | HANDLE BAR (Flush Cut) |
| 19 | 12021 | 2 | /P | WASHER - Conical (#10) |
| 20 | 80345 | 2 | | SCREW - Socket Cap (10-32 X 5/8") Torque Spec. 70 - 80 In/Lbs, 7.9 - 9.0 Nm; 262 Red Loctite Required |
| 21 | 82283 | 2 | | SCREW - Socket Cap (10-24 X 3/4") Torque Spec. 80 - 90 In/Lbs, 9.0 - 10.2 Nm; 262 Red Loctite Required |
| 22 | 82169 | 1 | | SCREW - Socket Cap (10-32 X 7/8") Torque Spec. 80 - 90 In/Lbs, 9.0 - 10.2 Nm; 262 Red Loctite Required |
| 23 | 12021 | 2 | /P | WASHER - Conical (#10) |
| 24 | A07435 | 1 | | NEST KIT (Includes 24, 51, 54, 55 & 56) |
| 25 | 81206 | 1 | S/P | NUT - Lock (#10) |
| 26 | A04624 | 1 | | HANDLE BAR (West Coast) |

8800HG Chain Saw UT-10810
Starter - Ignition - Exhaust System

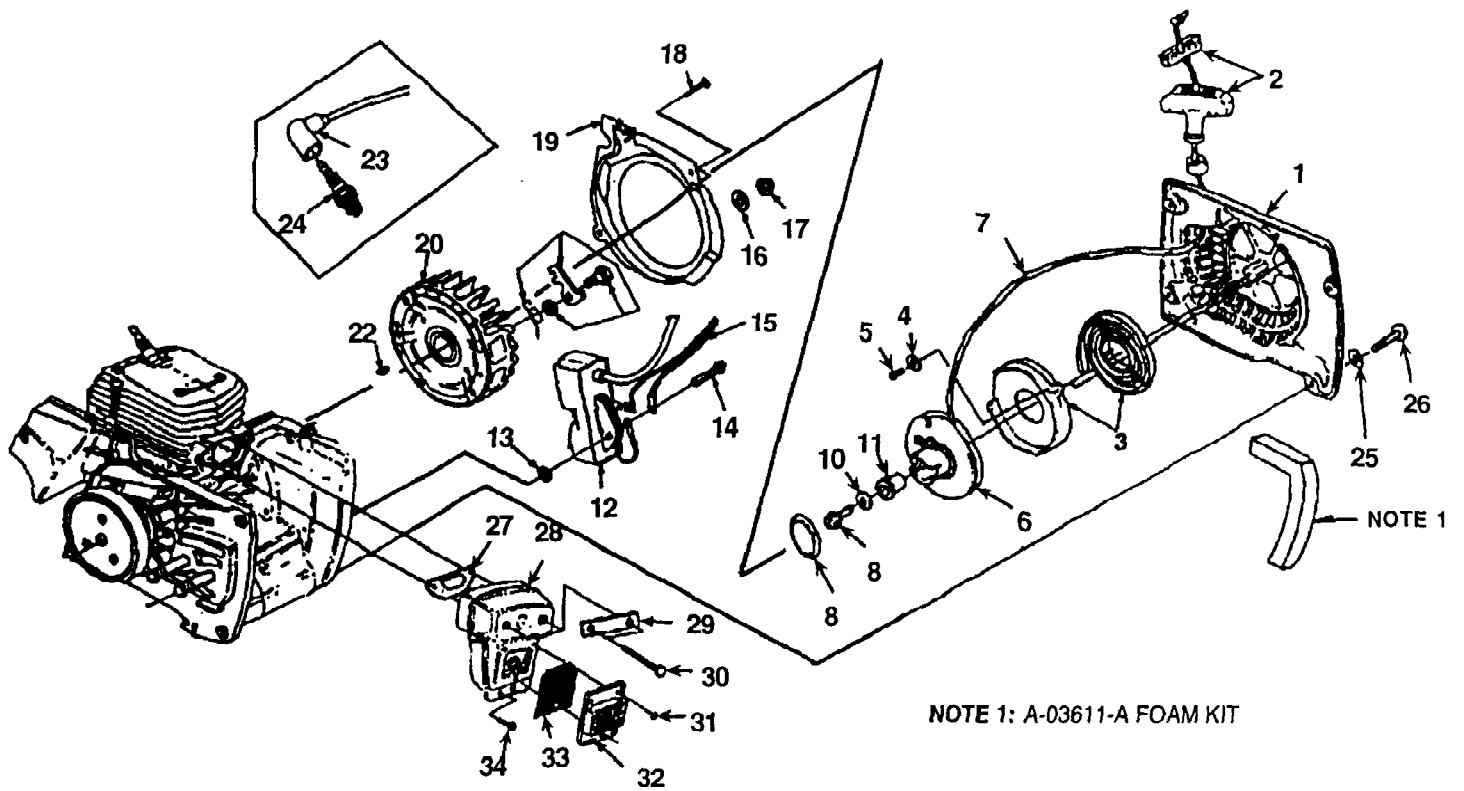

8800HG Chain Saw UT-10810
Starter - Ignition - Exhaust System

Page 12 of 12

| Ref # | Part Number | Qty | S/P/F | Description |
|-------|-------------|-----|-------|---|
| 1 | A02292A | 1 | S | STARTER COMPLETE |
| 2 | A69962B | 1 | /P | GRIP - W/INSERT |
| 3 | A98067A | 1 | /P | SPRING & RETAINER |
| 4 | 84025 | 3 | /P | WASHER - FLAT (#8) |
| 5 | 82528 | 2 | /P | SCREW - THREAD FORM (6 X 3/8") Torque Spec. 8 - 12 In/Lbs, .9 - 1.4 Nm |
| 6 | A97990C | 1 | S | PULLEY & ROPE |
| 7 | A00518 | 1 | S | ROPE |
| 8 | 02505 | 1 | | SPRING - GRIP |
| ?9 | 82409 | 1 | /P | SCREW - (10-14 X 5/8") Torque Spec. 30 - 40 In/Lbs, 3.4 - 4.5 Nm |
| 10 | 58763 | 1 | | WASHER - RETAINING |
| 11 | 97992A | 1 | S | BUSHING - STARTER POST |
| 12 | A04890A | 1 | /P | MODULE ASSY |
| 13 | 04617 | 2 | | SPACER |
| 14 | 88052 | 2 | /P | SCREW - HEX HD (10-24 X 7/8") Torque Spec. 50 - 60 In/Lbs, 5.6 - 6.8 Nm |
| 15 | A985831D | 1 | S | LEAD - GROUND W/GROMMET |
| 16 | 95479A | 1 | /P | WASHER - FLAT |
| 17 | 81255 | 1 | | NUT - LOCK HEX (3/8-24) Torque Spec. 250 - 300 In/Lbs, 28.2 - 33.9 Nm |
| 18 | 80582 | 2 | | SCREW MACH (8-32 X 5/8") Torque Spec. 30 - 40 In/Lbs, 3.4 - 4.5 Nm |
| 19 | 02133 | 1 | /P | SCROLL - AIR GUIDE |
| 20 | A02085B | 1 | S | ROTOR |
| ?21 | A03610 | 1 | | STARTER PAWL KIT |
| 22 | 75078 | 1 | | KEY - WOODRUFF |
| 23 | A33055 | 1 | /P | TERMINAL - SPARK PLUG |
| 24 | 98217S | 1 | /P | SPARK PLUG (RCJ6Y) Torque Spec. 120 - 180 In/Lbs, 13.6 - 20.3 Nm |
| 25 | 84003 | 4 | /P | WASHER - FLAT (#10) |
| 26 | 82562 | 4 | S | SCREW - PAN HD (10-24 X 5/8") Torque Spec. 40 - 50 In/Lbs, 4.5 - 5.6 Nm; 262 Red Loctite Required |
| 27 | 97682B | 1 | S | GASKET - MUFFLER |
| 28 | A04429 | 1 | | MUFFLER |
| 29 | 04431A | 1 | S | PLATE - RETAINING |
| 30 | 82592 | 2 | /P | SCREW - HEX CAP (1/4-20 X 3 1/4") Torque Spec. 100 - 140 In/Lbs, 11.3 - 15.8 Nm |
| 31 | 80560 | 3 | /P | SCREW - MACH (8-32 X 1/2") Torque Spec. 30 - 40 In/Lbs, 3.4 - 4.5 Nm |
| 32 | A98747 | 1 | | CAP - MUFFLER |
| 33 | 98827 | 1 | S | SCREEN - SPARK ARRESTOR |
| 34 | 825551 | 2 | S | SCREW - TRUSS HD (10-24 X 3/4") Torque Spec. 60 - 70 In/Lbs, 6.8 - 7.9 Nm |
| | A03611A | 1 | S | FOAM KIT |