

HOMELITE ELECTRIC EDGER - MODEL NUMBER UT45100

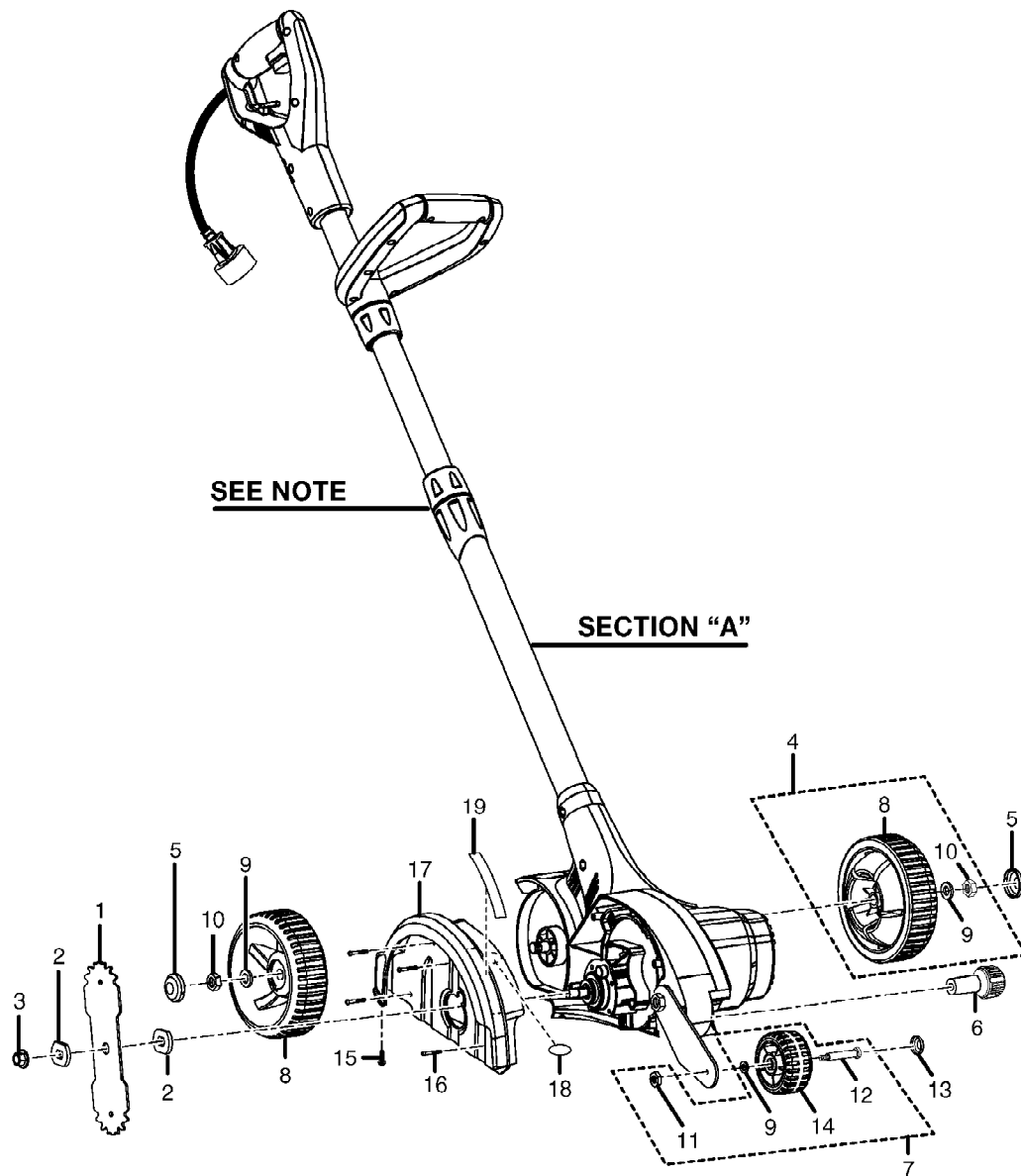

UT-45100 Electric Edger
General Assembly

Page 2 of 6

Ref #	Part Number	Qty	S/P/F	Description
1	33301261G	1		Blade
2	3330418G	2		Blade Washer
3	3221037G	1		Blade Nut (M10)
4	31202261G	1		Rear Wheel Set (Incl. Key Nos. 8-10)
5	34117261G	2		Rear Wheel Cap
6	34106261G	1		Depth Adjustment Knob
7	31203261G	1		Front Wheel Set (Incl. Key Nos. 9, 11 - 12 and 14)
8	31204261G	2		Wheel
9	33304261G	3		Washer (M8) Purchase locally
10	32208261G	2		Lock Nut (M8) Purchase locally
11	32907152G	1		Lock Nut (M6) Purchase locally
12	33283261G	1		Front Wheel Axle
13	34188261G	1		Front Wheel Cap
14	34111261G	1		Front Wheel
15	3220505G	1		Screw (M4 x 16 mm) Purchase locally
16	3220133G	4		Screw (M4 x 50 mm) Purchase locally
17	31108261G	1		Guard Assembly (Includes Key Nos. 18-19)
18	38108261G	1		Warning Label
19	38104261G	1		Cutting Edge Label

HOMELITE ELECTRIC EDGER - MODEL NUMBER UT45100

SECTION "A"

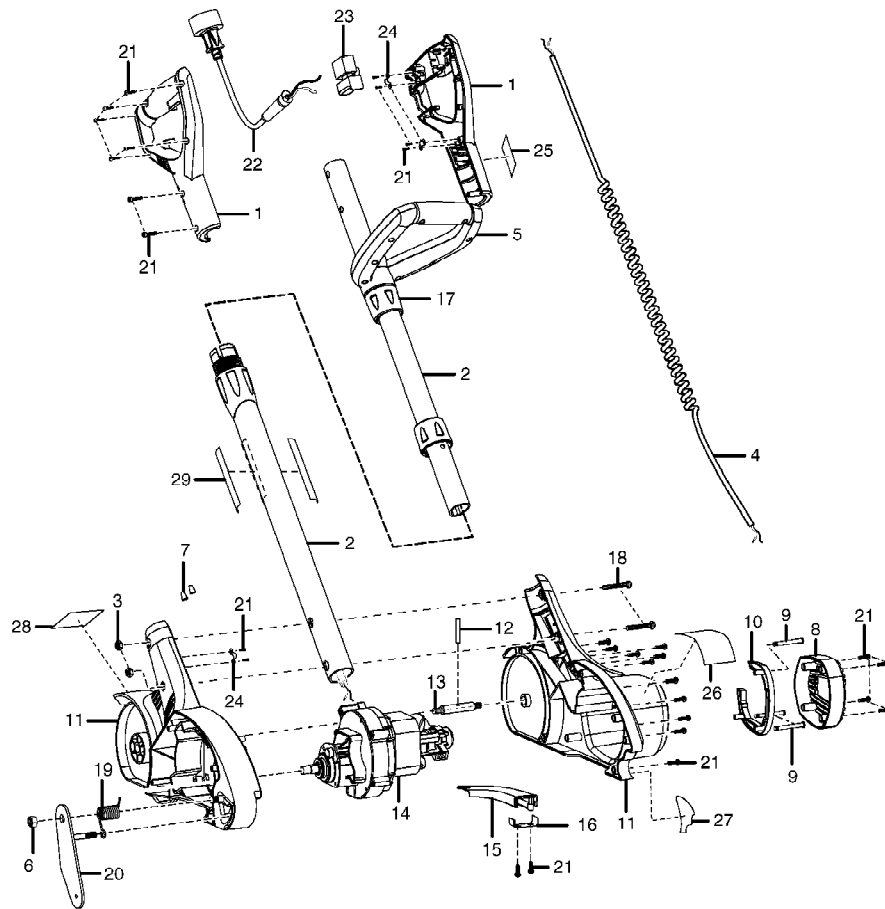

UT-45100 Electric Edger
Section "A"

Page 4 of 6

Ref #	Part Number	Qty	S/P/F	Description
1	31302261G	1		Handle Assembly
2	31102261G	1		Pole Assembly
3	32907152G	2		Hex Nut (M6) Purchase locally
4	36901261G	1		Spring Cord Assembly
5	31303261G	1		Auxiliary Handle Assembly
6	32208261G	1		Lock Nut (M8)
7	36511154G	2		Wire Nut
8	34104261G	1		Motor Cover
9	3220351G	3		Screw (M4 x 30 mm)
10	34105261G	1		Air Damper
11	34101261G	1		Housing Assembly
12	32988261G	1		Axle Pin
13	33201261G	1		Axle
14	31101261G	1		Motor Assembly
15	34108261G	1		Air Outlet
16	34116261G	1		Air Outlet Cover
17	34114152G	1		Collar
18	32901163G	2		Screw (M6 x 41 mm) Purchase locally
19	33401261G	1		Torsion Spring
20	33302261G	1		Front Wheel Arm
21	3220505G	30		Screw (M4 x 16 mm) Purchase locally
22	36401261G	1		Power Cord
23	36301261G	1		Switch
24	3410302G	3		Cord Clamp
25	38103261G	1		Handle Label
26	38101261G	1		Data Label
27	38107261G	1		Depth Adjustment Label
28	38106261G	1		Curb Runner Label
29	38102261G	2		Logo Label
	987000304	1		Operator's Manual

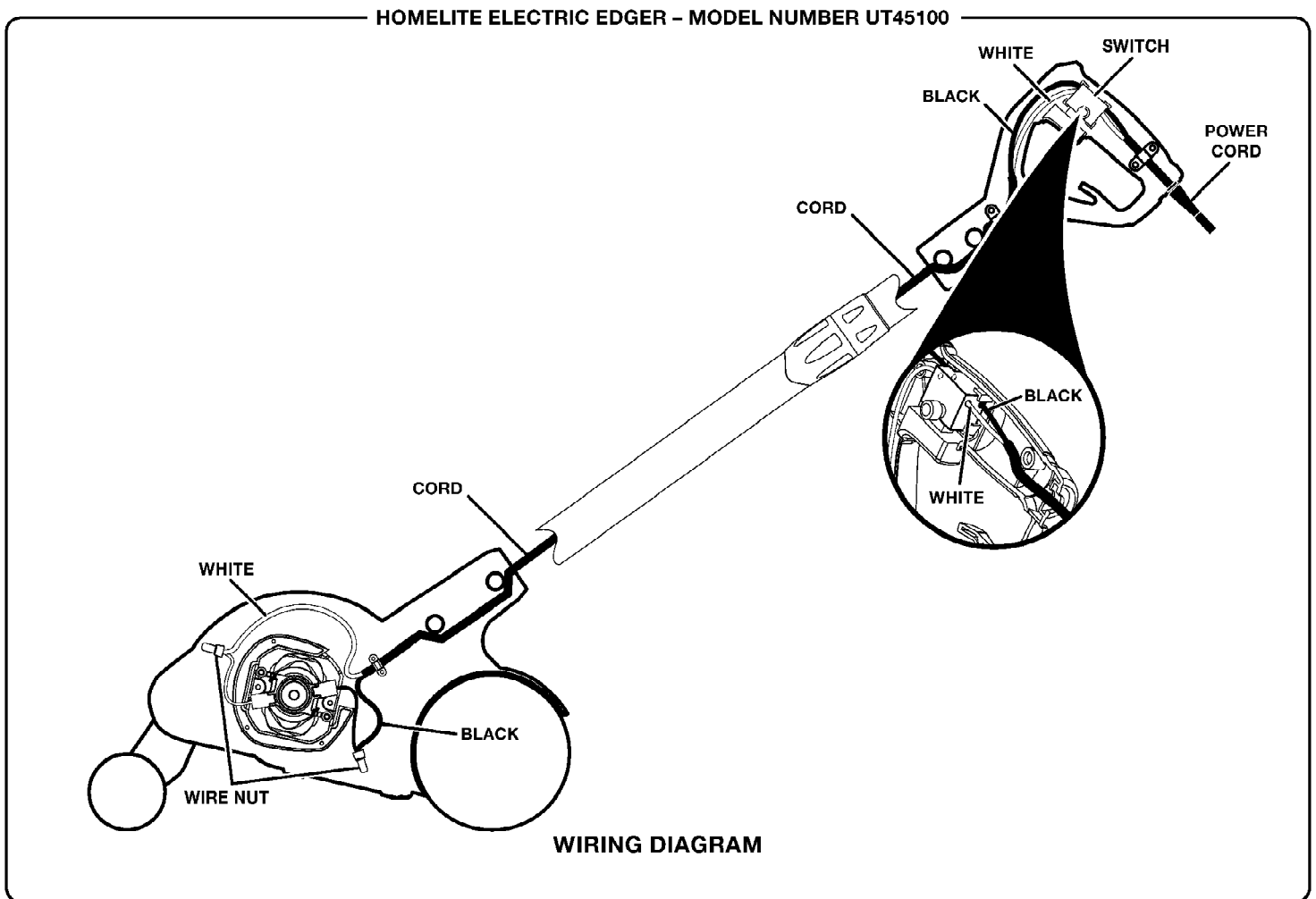

UT-45100 Electric Edger
Wiring Diagram

Page 6 of 6

Ref #	Part Number	Qty	S/P/F	Description
		1		No Parts List Available