

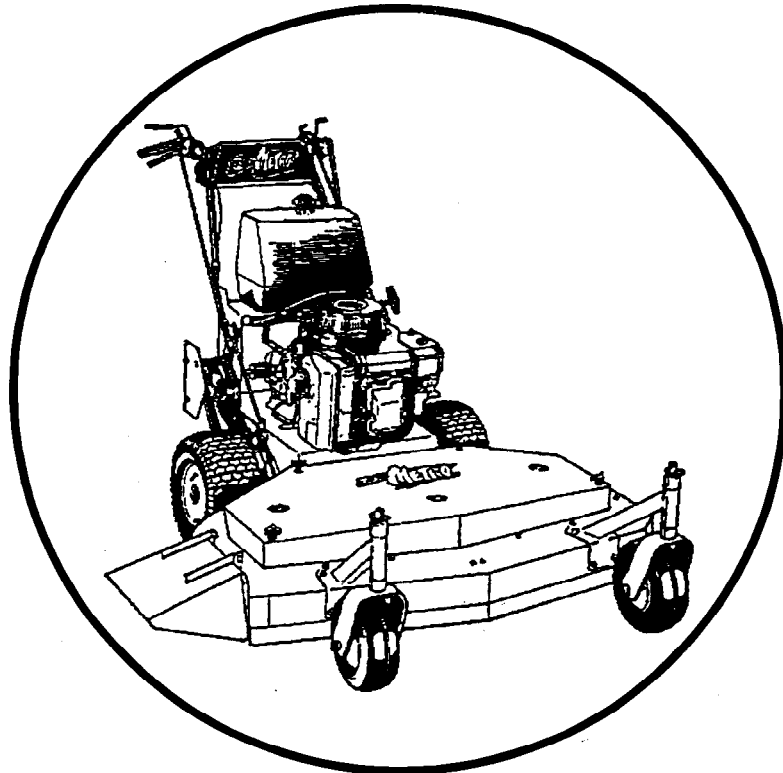

For Serial Nos.  
160,000 and Higher

# METRO



## Parts Manual

**CONGRATULATIONS** on the purchase of your new Exmark mower. This product has been carefully designed and manufactured to give you a maximum amount of dependability and years of trouble-free operation.

If additional information is needed, or should you require trained mechanic service, contact your authorized Exmark equipment dealer or distributor.

If you need to order replacement parts from your dealer, always give the model number and serial number of your mower as well as the part number, description and quantity of the part needed.

The Serial No. plate is located on the top front engine frame on the right hand side of the machine.

For ease of ordering and reference, we suggest that you record the information requested in the following identification table.

Model No. \_\_\_\_\_

Serial No. \_\_\_\_\_

Date Purchased \_\_\_\_\_

Purchased From \_\_\_\_\_

Paste Label From  
Literature Packet Here

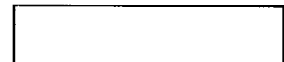

# EXMARK PARTS PLUS® PROGRAM

**EFFECTIVE DATE: September 1, 1995**

## Program

If your Exmark dealer does not have the Exmark part in stock, Exmark will get the parts to the dealer the next business day or the part will be FREE\* Guaranteed!!

## *How the Program Works*

1. If dealer does not have part in stock for a "down" unit at the time of request by customer, the dealer contacts his distributor by 1:00 p.m., local time, and requests Exmark Parts Plus® shipment of six (6) line items or less.
2. Distributor ships part(s) to dealer or customer, as requested by dealer, same day, overnight UPS. Distributor bills dealer for part and freight charges where applicable.
3. If distributor does not have the part(s) in stock to satisfy Exmark Parts Plus® order, he contacts Exmark by 3:00 p.m., central time, with an Exmark Parts Plus® order of six (6) line items or less.
4. If order is received by 3:00 p.m. central time, Exmark ships part(s) direct to dealer or customer, as requested by distributor, same day, overnight UPS. Exmark bills the distributor for parts and shipping charges, where applicable.
5. The customer pays for the part and freight if it is shipped under the Exmark Parts Plus® and if it arrive in accordance to the program.
6. Who pays for the part and freight if it fails to arrive overnight in accordance to the program?
  - A. Under any circumstance the customer does not pay.
  - B. If the part does not arrive overnight due to:
    1. The dealer not submitting the Exmark Parts Plus® order to his Exmark distributor by 1:00 p.m., the dealer pays for the part and freight.
    2. The Distributor being unable to ship the part the same day or not submitting the Exmark Parts Plus® order to Exmark by 3:00 p.m., central time, the Distributor pays for the part and freight.
    3. Exmark being unable to ship the part and the Exmark parts order is received by 3:00 p.m., central time, Exmark pays for the part and freight.
    4. If the part does not arrive overnight due to the shipper (UPS), the shipper pays for the freight and Exmark pays for the part.



**The following restrictions apply** -- The Exmark Parts Plus® Program is available only through participating Exmark Dealers and applies only to orders submitted on this program Monday through Thursday. UPS has initiated a Saturday delivery program to many areas of the continental United States and can be requested for an overnight shipment on Friday to be delivered Saturday. The next day air charge, plus the Saturday delivery fee will be the responsibility of the purchaser. Exmark Mfg. will assume no responsibility for Saturday delivery shipments. To qualify, all Exmark Parts Plus® orders must be received by Exmark by 3:00 p.m., central time. Orders must be six (6) line items or less. Exclusions from the Exmark Parts Plus® Program are: Any wholegood or accessory in its entirety, engines and engine replacement parts, 5-speed Peerless transmissions and 5-speed transaxles, hydraulic or hydrostatic wheel motors, cutter decks and engine decks or any item exceeding United Parcel Service size and weight restrictions.

Due to UPS restrictions, aerosol spray paint is considered a hazardous material and cannot be shipped via UPS next day or Second Day Air.

Exmark Manufacturing stocks a limited supply of parts for transaxles, pumps and wheel motors. These parts can be ordered for Next Day Air shipment but will not be guaranteed per the Parts Plus Program.



**READ OPERATOR'S MANUAL BEFORE  
OPERATING OR SERVICING EXMARK EQUIPMENT.**

## **TABLE OF CONTENTS**

<b><u>Description</u></b>	<b><u>Page</u></b>
Decals.....	12 - 13
Engine Deck Group.....	6 - 9
48" Mower Deck .....	4 - 5
32" and 36" Mower Deck .....	2 - 3
Wiring Diagrams .....	14
Upper Handles & Controls .....	10 - 11

# 32" and 36" MOWER DECK

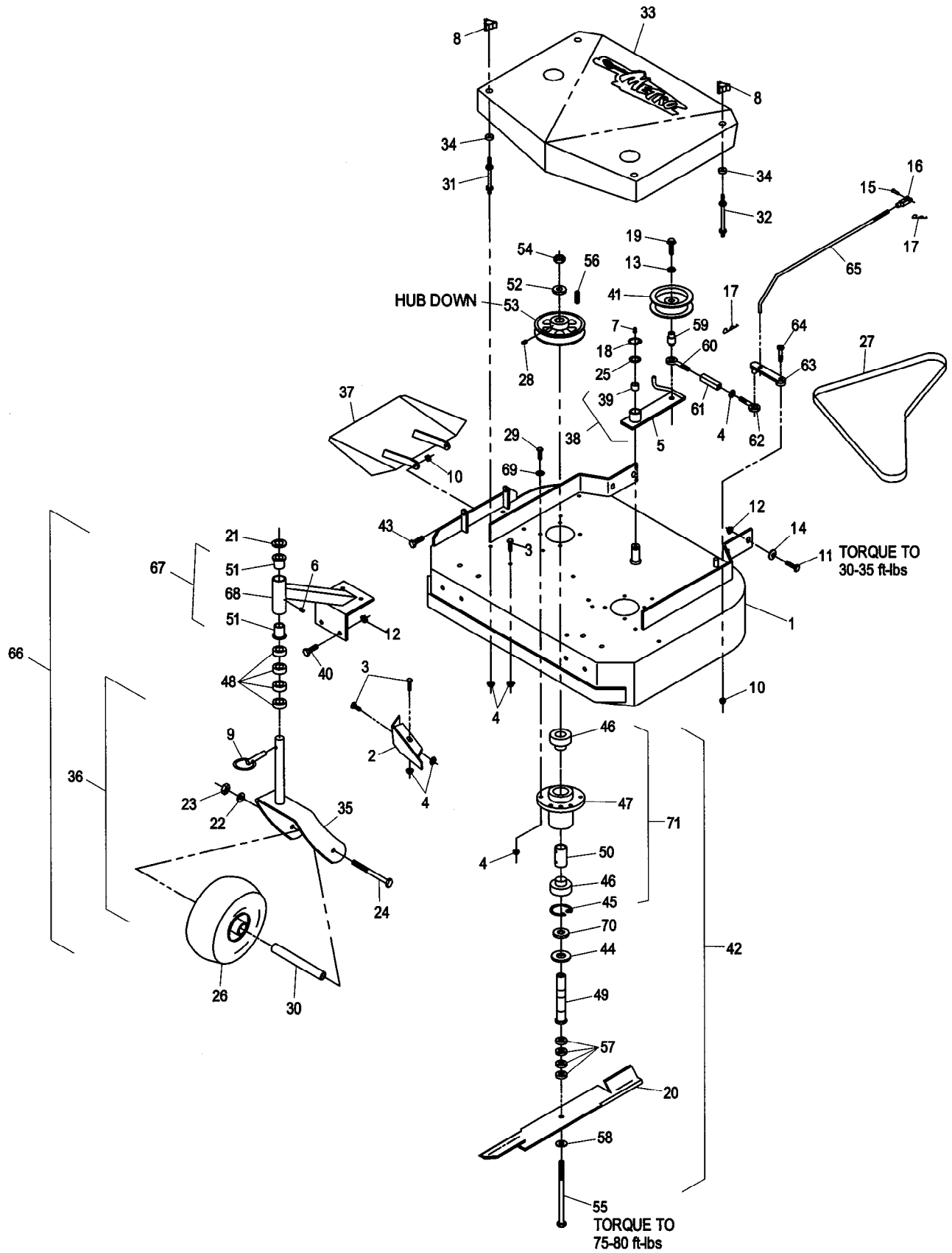

### 32" and 36" MOWER DECK

Ref. No.	Part No.	Description	Qty. Req'd.	Ref. No.	Part No.	Description	Qty. Req'd.
1	304253	Front Deck w/decals & dogleg (36")...	1	31	303537	Stud, belt shield (short).....	2
	302232	Deck weldmt (36") .....	1	32	303536	Stud, belt shield (long).....	2
	324288	Front Deck w/decals & dogleg (32")...	1	33	324208	Shield w/decals, 36" Metro .....	1
	322204	Deck weldmt (32") .....	1		302213	Shield weldmt, 36" Metro.....	1
2	302189	Baffle wldmnt, dogleg.....	1		324194	Shield w/decals, 32" Model.....	1
3	800270	5/16-18 x 5/8 HHCS .....	8		322149	Shield weldmt, 32" Model .....	1
4	809001	5/16-18 Whizlock nut.....	20	34	323417	Washer, belt cover mount .....	4
5	302128	Arm weldmt .....	1	35	322145	Fork wldmnt, caster .....	2
6	811001	Grease Zerk .....	2	36	322154	Caster wheel assembly .....	2
7	811006	Zerk, 1/4-28 STRT .....	1	37	302054	Chute .....	1
8	323385	Knob, belt cover .....	4	38	302129	Engagement arm w/bushing.....	1
9	809020	Quick pin, 10" caster .....	2	39	303144	Powder metal bearing.....	1
10	804256	5/16-18 Nyloc hex nut.....	3	40	800290	3/8-16 x 3/4 HH capscrew .....	8
11	800293	3/8-16 x 1 1/4 HH capscrew .....	6	41	603843	Idler pulley (heavy duty).....	1
12	809007	3/8-16 whizlock nut.....	8	42*	324265	Cutter Housing Complete .....	2
13	805259	3/8 Flatwasher.....	1	43	800273	5/16-18 x 1 HH capscrew .....	2
14	303327	3/8 Disc spring washer.....	6	44	633573	Guard, bottom.....	2
15	808280	5/16 x 1 Clevis pin .....	1	45	808502	Retaining ring .....	2
16	303105	Yoke .....	1	46	513016	Bearing .....	4
17	806003	Cotter hairpin.....	2	47	323532	Cutter housing .....	2
18	808505	E-Ring for .875 rd. ....	1	48	303314	Spacer, 10" caster.....	8
19	803003	3/8-16 x 1 3/4 Whizlock bolt .....	1	49	323529	Tube, spindle .....	2
20	633482	Blade, Notched air foil (36").....	2	50	323528	Spacer .....	2
	613251	Blade, Solid air foil (36").....	2	51	303514	Flange , thrust bearing .....	4
•	633484	Blade, Mulching (36") .....	2	52	323339	Retaining washer, sheave .....	2
	633485	Blade, Low Lift (36") optional.....	2	53	303558	Pulley, cast iron .....	2
	323515	Blade, Notched air foil (32").....	2	54	804510	5/8-18 UNF hex nut .....	2
	323515	Blade, Solid air foil (32").....	2	55	800861	5/8-18 x 8 HH Capscrew (Gr 5).....	2
•	403148	Blade, Mulching (32") .....	2	56	807267	Key, 1/4 x 3/16 x 1 1/4.....	2
	403149	Blade, Low Lift (32") optional.....	2	57	323539	Spacer, blade drive.....	8
21	513338	Washer, special.....	2	58	513208	5/8 Spring disc washer .....	2
22	805008	1/2 spring lockwasher.....	2	59	303434	Engagement bushing.....	1
23	804509	1/2-13 Hex nut.....	2	60	303348	Eye bolt (left hand thread) .....	1
24	800334	1/2-13 x 6 HH capscrew .....	2	61	303236	Turnbuckle body .....	1
25	303352	Washer, spindle .....	1	62	303238	Eye bolt (right hand thread) .....	1
26	513648	Wheel & tire, complete .....	2	63	302198	Assist arm.. .....	1
	513807	Wheel & hub.....	1	64	809011	3/8 x 3/4 Shoulder bolt.....	1
	513808	Tire, 9 x 3.50-4 4-ply .....	1	65	323303	Assist arm linkage .....	1
	513809	Roller bearing .....	1	66	322153	Caster/mount, complete .....	1
	513810	Bushing.....	2	67	302203	Caster wheel support w/bearings .....	2
27	323299	Drive belt (to blades) 36" Model .....	1	68	302194	Caster wheel support wldmnt .....	2
	323345	Drive belt, (to blades) 32" Model .....	1	69	303334	5/16 Spring disc washer .....	8
◆28	803310	Setscrew, 5/16-18 x 3/8.....	2	70	323533	Spacer .....	2
29	800274	5/16-18 x 1 1/4 HH capscrew .....	8	71	634619	Housing w/Brg, Spacer and Ring .....	2
30	513547	Spacer, front caster.....	2				

◆ Use Pro-lock Nut Type (p/n 840022 .5 ml tube) on setscrews

• Requires installation of Micro-Mulch accessory for proper mulching. Mulch kit P/N's MK322(32") or MK362(36")

\* Cutter housing complete includes sheave, washer, and nut.

Exmark red touch up spray paint - P/N 850337

# 48" MOWER DECK

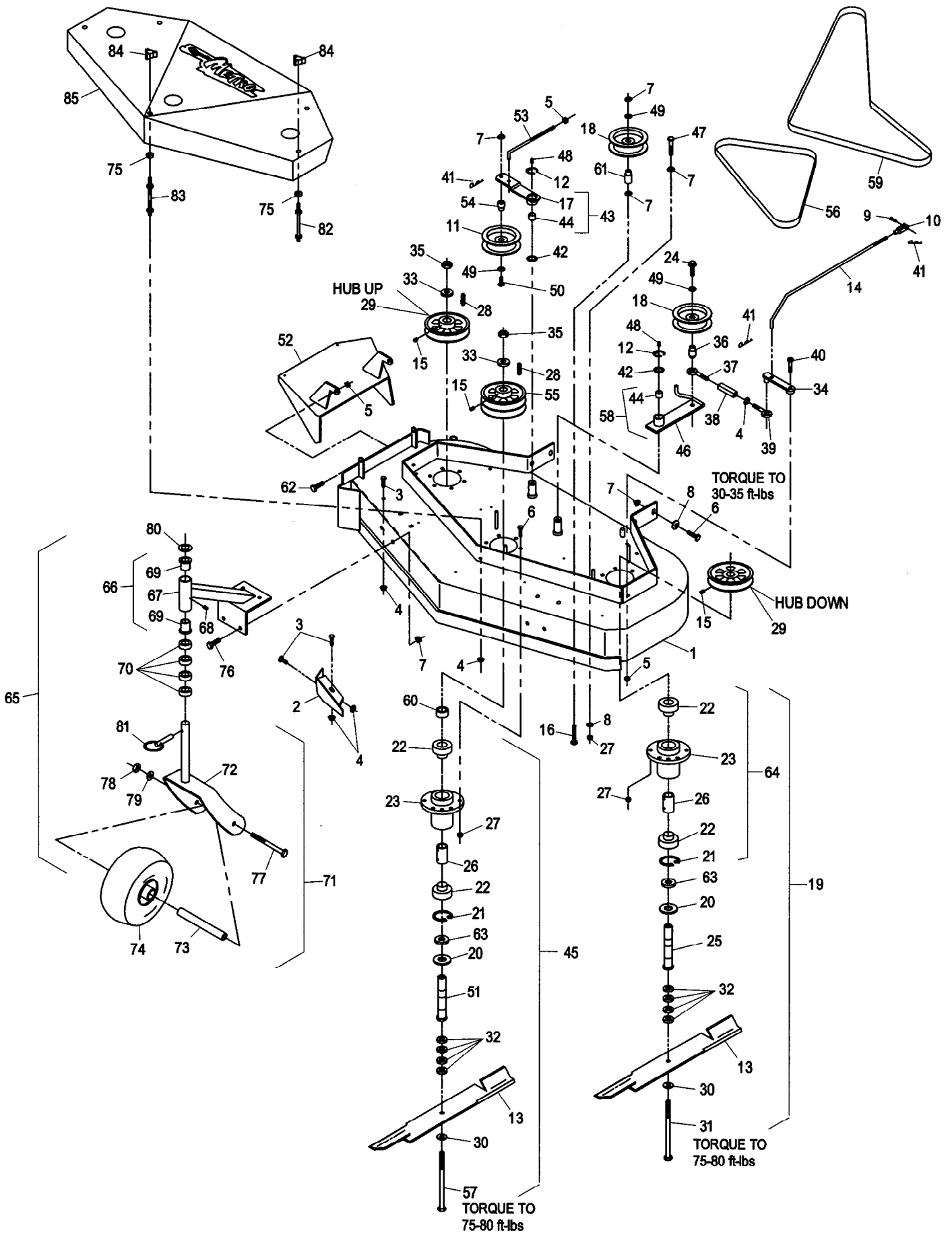

## 48" MOWER DECK

Ref. No.	Part No.	Description	Qty. Req'd.	Ref. No.	Part No.	Description	Qty. Req'd.
*1	404239	Front Deck w/decals & dogleg (48")...	1	44	303144	Powder metal bearing .....	2
*	402099	Deck Weldmt, (48") .....	1	45*	324264	Cutter Housing Complete (center) .....	1
2	402107	Baffle, dogleg .....	1	46	302128	Arm weldmt .....	1
3	800270	5/16-18 x 5/8 HH capscrew .....	10	47	800299	3/8-16 x 2 3/4HHCS .....	1
4	809001	5/16-18 Whizlock nut.....	16	48	811006	Zerk 1/4-28 strt .....	2
5	804256	5/16-18 Nyloc hex nut.....	4	49	805259	3/8 Flatwasher.....	3
6	800293	3/8-16 x 1 1/4 HH capscrew .....	24	50	800295	3/8-16 X 1 3/4 HH capscrew .....	1
7	809007	3/8-16 whizlock nut.....	18	51	323530	Cutter spindle ,center .....	1
8	303327	3/8 disc spring washer.....	7	52	402106	Chute wldmt .....	1
9	808280	5/16 x 1 Clevis pin .....	1	53	403107	Belt tension rod .....	1
10	303105	Yoke .....	1	54	603496	Bushing, idler bearing .....	1
11	403119	Idler pulley "V" .....	1	55	403133	Double pulley .....	1
12	808505	E-Ring for .875 rd. ....	2	56	403025	V-Belt, front deck .....	1
13	323515	Blade, Notched air foil (48").....	3	57	800862	5/8-18 x 8 1/2 HH capscrew, Gr5.....	1
	413438	Blade, Solid air foil (48") .....	3	58	302129	Engagement arm w/bushing .....	1
•	403148	Blade, mulching (48") .....	3	59	323300	Drive belt (main deck) 48".....	1
	403149	Blade, Low Lift (48") optional.....	3	60	323538	Spacer, bearing .....	1
14	323303	Assist arm linkage .....	1	61	543879	Bushing .....	2
◆15	803310	Setscrew, 5/16-18 x 3/8.....	3	62	800273	5/16-18 x 1 HH capscrew.....	2
16	800029	3/8-16 x 2 1/4 HH tapbolt .....	1	63	323533	Spacer .....	2
17	402052	Arm weldmt, RH .....	1	64	634619	Housing w/Brg, Spacer and Ring .....	3
18	603843	Idler pulley .....	1	65	322153	Caster/mount, complete.....	2
19*	324265	Cutter Housing Complete (outer) .....	2	66	302203	Caster wheel support w/bearings.....	2
20	633573	Guard, bottom .....	3	67	302194	Caster wheel support wldmnt.....	2
21	808502	Retaining ring .....	3	68	811001	Grease zerk, 1/8 N.P.T. ....	2
22	513016	Bearing .....	6	69	303514	Flange, thrust bearing .....	4
23	323532	Cutter housing .....	3	70	303314	Spacer, 10" caster.....	8
24	803003	3/8-16 x 1 3/4 Whizlock bolt .....	1	71	322154	Caster wheel assembly.....	2
25	323529	Cutter spindle tube .....	2	72	322145	Fork wldmnt, caster.....	2
26	323528	Spacer .....	3	73	513547	Spacer, front caster.....	2
27	804257	Nut, nylock 3/8-16 .....	18	74	513648	Wheel & tire, complete.....	2
28	807267	Key, 1/4 x 3/16 x 1 1/4.....	3		513807	Wheel & hub .....	2
29	303558	Pulley, cast iron .....	2		513808	Tire, 9 x 3.50-4 4-ply .....	2
30	513208	5/8 Spring disc washer .....	3		513809	Roller bearing.....	2
31	800861	5/8-18x8 HH Capscrew(Gr5).....	2		513810	Bushing .....	4
32	323539	Spacer, blade drive .....	12	75	323417	Washer, belt cover mount.....	4
33	323339	Washer, retainer (sheave).....	3	76	800290	3/8-16 x 3/4 HH capscrew.....	8
34	302198	Assist arm.....	1	77	800334	1/2-13 x 6 HH capscrew.....	2
35	804510	5/8-18 UNF hex nut.....	3	78	804509	1/2-13 Hex nut .....	2
36	303434	Engagement bushing .....	1	79	805008	1/2 spring lockwasher .....	2
37	303348	Eye bolt (left hand thread) .....	1	80	513338	Washer, special .....	2
38	303236	Turnbuckle body.....	1	81	809020	Quick pin, 10" caster.....	2
39	303238	Eye bolt (right hand thread) .....	1	82	303537	Stud, belt shield (short) .....	2
40	809011	3/8 x 3/4 Shoulder bolt .....	1	83	303536	Stud, belt shield (long) .....	3
41	806003	Cotter hairpin.....	3	84	323385	Knob, belt cover .....	4
42	303352	Washer, spindle .....	2	85	404238	Shield w/decals 48" Metro.....	1
43	402053	Idler arm, complete (w/bushing).....	1		402100	Shield weldmt, 48" Metro .....	1

◆ Use Pro-lock Nut Type (p/n 840022 .5 ml tube) on setscrews

• Requires installation of Micro-Mulch accessory for proper mulching. Mulch kit P/N's MK48M3  
Exmark red touch up spray paint - P/N 850337

\* Deck weldmt does include welded in flow control baffles.

\* Cutter housing complete includes sheave, washer, and nut.

# ENGINE DECK GROUP

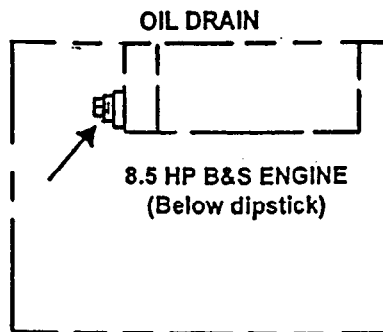
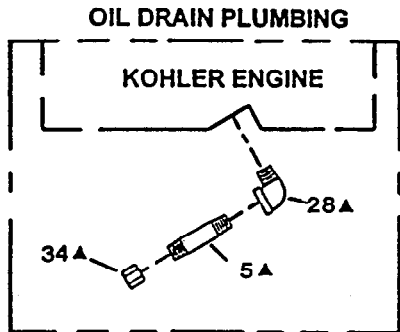
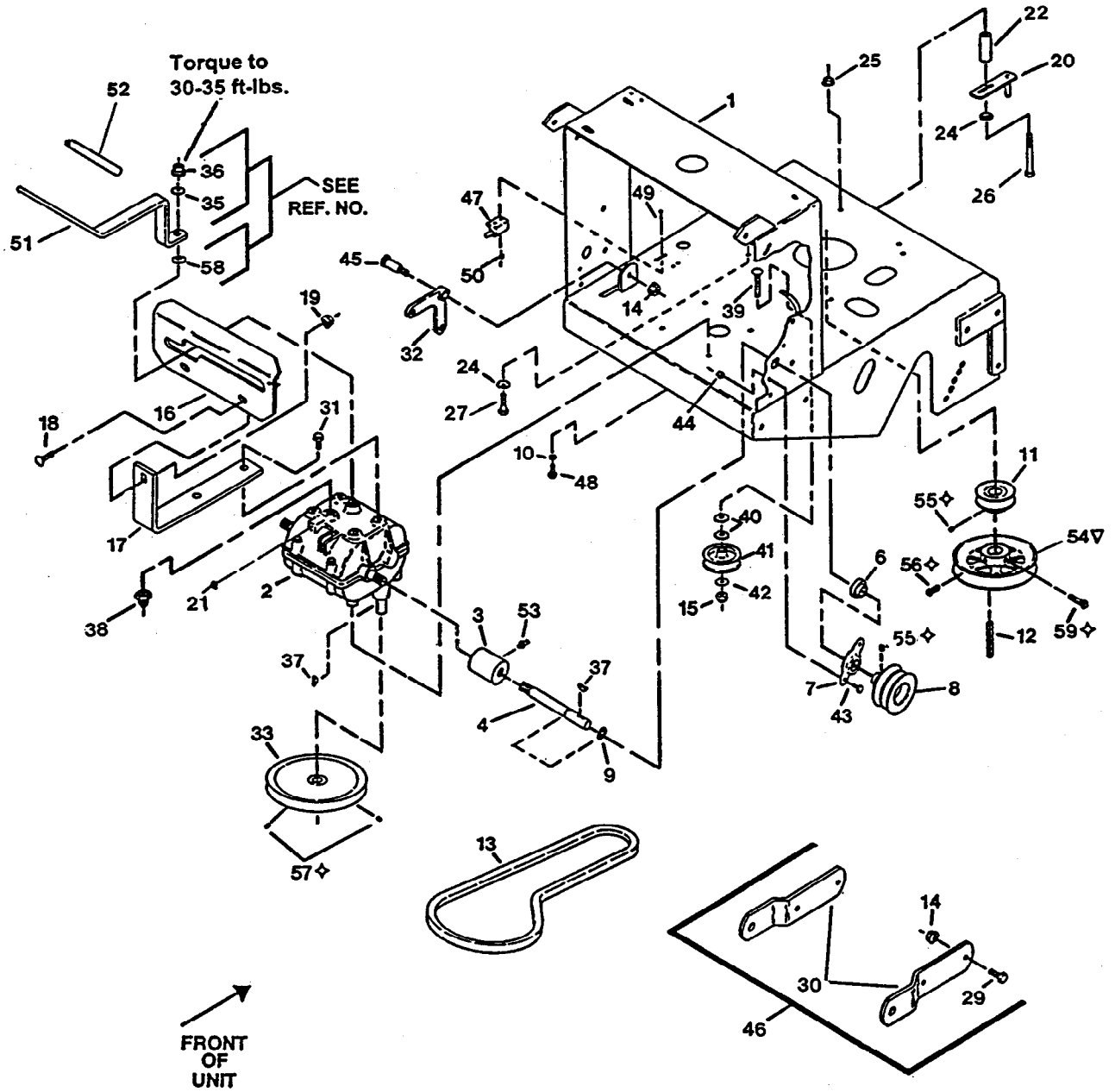



## ENGINE DECK GROUP

Ref. No.	Part No.	Description	Qty. Req'd.	Ref. No.	Part No.	Description	Qty. Req'd.
1	322201	Rear deck .....	1	28▲	303431	St. Elbow (brass) 3/8 NPT .....	1
2	323500	Transmission .....	1	29	800292	3/8-16 x 1 HH capscrew .....	4
3	323501	Coupling, transmission shaft .....	2	30	323318	Hitch bracket.....	2
4	323502	Output shaft, transmission.....	2	31	809013	5/16-18 x 3/4 Tapping screw .....	4
5▲	323326	Nipple (galvanized) 3/8 NPT x 3.0 .....	1	32	303186	Bell crank .....	1
6	323252	Shaft bearing, transmission.....	2	33●	323278	Sheave, transmission drive.....	1
7	323254	Bearing flange, transmission shaft .....	2	34▲	543233	Cap (hex) 3/8 NPT.....	1
8	323257	Sheave, wheel drive, 3 1/4" .....	2	35	303327	3/8 Spring disc washer .....	1
	323363	Sheave, wheel drive, 3 1/4" (32").....	2	36	804264	3/8-24 Hex nylock nut .....	1
9	808523	Retaining ring.....	2	37	807009	3/16 x 3/4 Woodruff key.....	3
10	805005	5/16 spring lockwasher.....	4	38	303282	Neutral start switch .....	1
11	323256	Sheave, transmission drive, 2 3/4" .....	1	39	807511	3/8-16 x 2 Carriage bolt, SSN.....	1
12	807264	1/4 sq. x 2 5/8 Key .....	1	40	805262	7/16 Std. Flatwasher .....	2
13	323280	Belt, transmission .....	1	41	323285	Idler pulley, transmission drive.....	1
14	809007	3/8-16 Whizlock nut.....	5	42	805259	3/8 SAE flatwasher .....	1
15	804257	3/8-16 Nyloc nut.....	1	43	800251	1/4-20 x 5/8 HH capscrew .....	4
16	323387	Shifter plate .....	1	44	804255	1/4-20 Nyloc nut.....	4
17	323389	Leg, shifter lever .....	2	45	603403	1/2 x 1 Shoulder bolt.....	1
18	807503	5/16-18 x 3/4 Carriage bolt .....	2	46	301023	Sulky Hitch Kit, Metro.....	1
19	809001	5/16-18 Whizlock nut .....	2	47	513051	Blade engagement switch.....	1
20	322110	Belt guide wldmnt (32" and 36") .....	2	48	800271	5/16-18 x 3/4 HH capscrew .....	4
	322110	Belt guide wldmnt (48" and 52") .....	3	49	803028	10-24 x 5/8 Pan Hd. ....	2
21	323526	Ball S.S detent .....	1	50	804252	10-24 Nyloc nut.....	2
22	323228	Spacer, belt guide (32" and 36").....	2	51	323376	Shift lever... ..	1
	323228	Spacer, belt guide (48" and 52").....	3	52	323250	Foam grip... ..	1
23	301024	Kit, Metro transmission .....	1	53	811006	1/4-28 Grease zerk (straight).....	2
24	303334	5/16 disc spring washer .....	4	54▽	303498	Pulley, blade drive (6 1/8").....	1
25	809001	5/16-18 Whizlock nut.....	4			(For 36" and 52" Models)	
		(Only with B/S engine)			403087	Pulley, blade drive (6 3/4").....	1
		(For 32" and 48" Models)					
26*	800283	5/16-18 x 3 1/2 HH capscrew .....	2	55◇	803310	5/16-18 x 3/8 Cuppoint setscrew .....	3
		(With 32" Model 8.5 HP B&S Engine)		56◇	803050	5/16-18 x 3/4 Sq. setscrew .....	1
	809065	M8-1.25 x 75mm HH capscrew .....	2	57◇	803293	1/4-20 x 3/8 Cuppoint setscrew .....	2
		(32" and 36" Kawasaki & Kohler)		58	323379	Washer, shifter lever.....	1
	809065	M8-1.25 x 75mm HH capscrew .....	3	59◇	803046	5/16-18 x 1 Sq. setscrew .....	1
		(48" and 52" Kawasaki & Kohler)					
27*	800275	5/16-18 x 1 1/2 HH capscrew .....	2				
		(With 32" Model 8.5 HP B&S Engine)					
	809072	M8-1.25 x 25mm HH capscrew .....	2				
		( 32" & 36" Kawasaki & Kohler)					
	809072	M8-1.25 x 25mm HH capscrew .....	1				
		(48" and 52" Kawasaki & Kohler)					

◇ Use Pro-lock (Nut type) Part No. 840022 (.5mm tube) on setscrew threads

▽ Apply anti-seize compound to pulley bore(blade drive pulley)

▲ Use Teflon Pipe Sealant (or equivalent) on all threaded areas.

\* Torque Engine Mounting Bolts: Briggs & Stratton to 15-20 ft-lbs / Kohler & Kawasaki to 25-30 ft-lbs.

• Apply loctite RC609 to pulley bore (transmission pulley)

Exmark red touch up spray paint - P/N 850337

Exmark black touch up spray paint - Gloss black

# ENGINE DECK GROUP (con't)

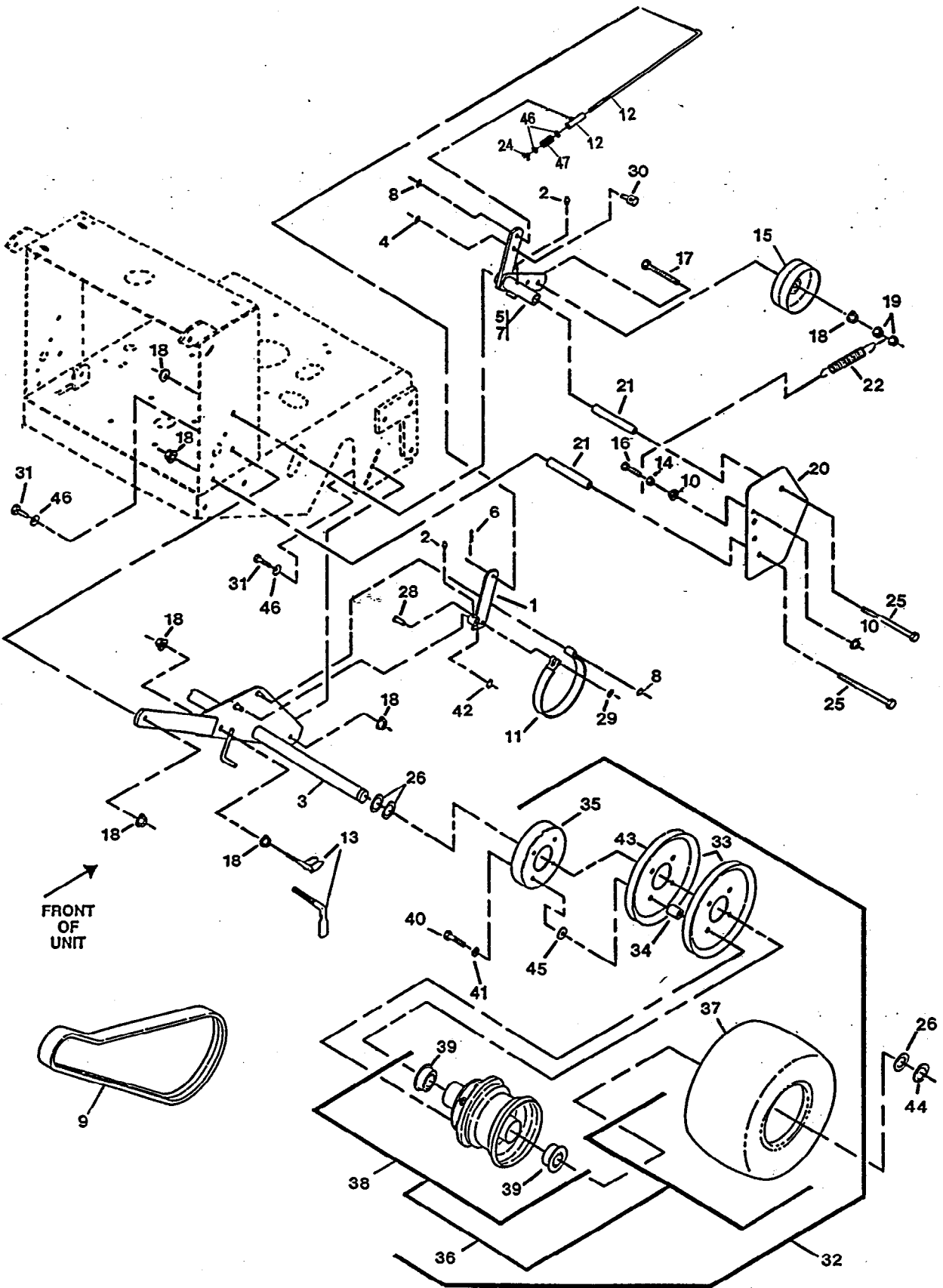

## ENGINE DECK GROUP (con't)

Ref. No.	Part No.	Description	Qty. Req'd.	Ref. No.	Part No.	Description	Qty. Req'd.
1	322113	Brake arm wldmnt .....	2	26	523157	Spacer, wheel (14 Ga.).....	As Req'd.
2	811006	1/4-28 Grease zerk (straight) .....	4		543436	Spacer, wheel (18 Ga.).....	As Req'd.
3	322117	Axle wldmnt .....	1	27	303327	3/8 Disc spring washer .....	4
	322141	Axle wldmnt (32" Model).....	1	28	323307	3/8 Clevis pin .....	2
4	808520	Klipring (for .31 shaft) .....	2	29	803051	3/8 Pushnut.....	2
5	322119	Idler arm wldmnt (LH).....	1	30	323368	Swivel, short adjust.....	2
6	806003	Cotter hairpin, #2.....	2	31	800292	3/8-16 x 1 HH capscrew .....	4
7	322121	Idler arm wldmnt (RH) .....	1	32	324146	Drive wheel, complete .....	2
8	808522	Klipring (for 3/8 shaft) .....	4		324193	Drive wheel, complete (32" Model)....	2
9	323288	Belt, wheel drive .....	2	33	323253	Sheave, wheel drive (8" A) .....	4
	323344	Belt, wheel drive (32" Model).....	2	34	323260	Spacer, wheel sheave .....	8
10	809001	5/16-18 Whizlock nut.....	4	35	323261	Brake drum .....	2
11	323262	Brake band.....	2	36	323276	Wheel and tire, complete.....	2
12	322125	Swivel wldmnt, brake linkage .....	2		323346	Wheel & Tire, complete(32"Model)....	2
13	412358	Scraper wldmnt .....	2	37	303125	Tire, 13 x 6.50 - 6 (4-ply) .....	1
	603430	Scraper (32" Model) .....	2		323361	Tire, 13 x 5.00 - 6 (4-ply)(32"Model)..	1
14	804256	5/16-18 Nyloc nut .....	2	38	323328	Wheel & hub w/brgs(36" & 48" Model)	1
15	323277	Idler pulley, wheel drive .....	2		323360	Wheel & hub w/bearings(32" Model) .	1
	323352	Idler pulley, wheel drive (32" Model)...	2	39	323329	Bearing, flanged.....	4
16	800274	5/16-18 x 1 1/4 HH capscrew .....	2	40	800273	5/16-18 x 1 HH capscrew (32").....	4
17	800032	3/8-16 x 3 HH Tap bolt .....	2		800274	5/16-18 x 1 1/4 HH capscrew .....	4
18	809007	3/8-16 Whizlock nut.....	14	41	805005	5/16 Spring washer.....	8
19	804257	3/8-16 Nyloc nut .....	4	42	808501	E-Ring (for 1/2" shaft) .....	2
20	323287	Shield, wheel drive .....	2	43	323349	Sheave, wheel drive (32"Model) .....	1
21	323283	Spacer .....	4	44	808519	E-Ring (for 1" shaft) .....	2
22	603402	Drive spring .....	2	45	373034	Swivel washer (32" Model only).....	4
23	323548	Brake rod.....	2	46	805257	5/16 SAE Flat washer .....	4
24	513959	5/16-18 Nyloc wingnut.....	2	47	323245	Spring, Compression .....	2
25	800306	3/8-16 x 5 HH capscrew .....	4				

Exmark black touch up spray paint - Gloss black

# UPPER HANDLE and CONTROLS

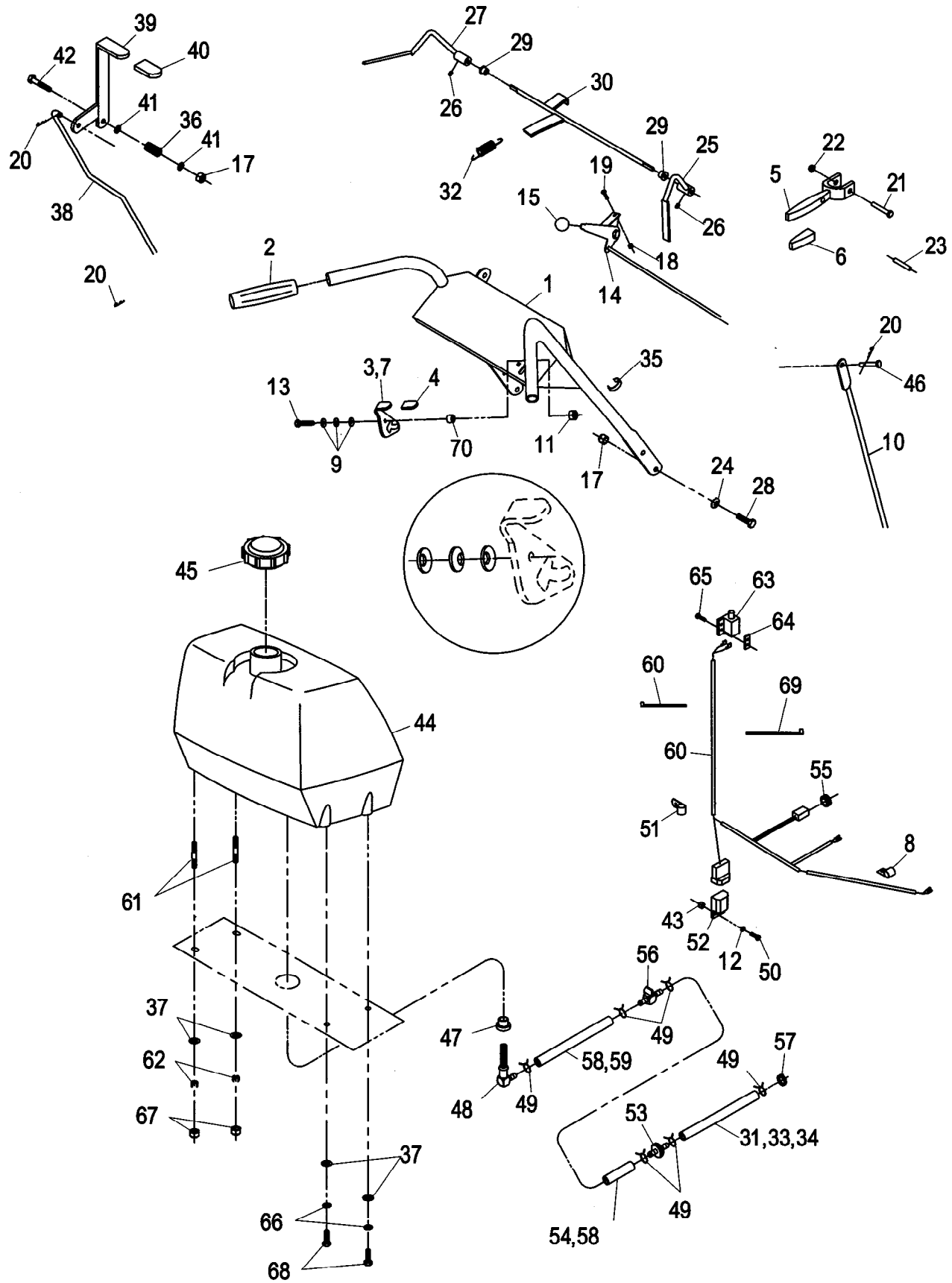

## UPPER HANDLES & CONTROLS

Ref. No.	Part No.	Description	Qty. Req'd.	Ref. No.	Part No.	Description	Qty. Req'd.
1	322190	Handle wldmnt .....	1	37	805257	Washer, 5/16 SAE.....	1
2	303097	Handle grip.....	2	38	323298	Linkage, blade drive .....	1
3*	324279	Latch w/grip (left).....	1	39	322157	Engagement lever, blade w/grip.....	1
4	303019	Grip, latch .....	2	40	303020	Grip, lever.....	1
5	302006	Drive lever w/grip .....	2	41	805260	3/8 Std. flatwasher.....	2
6	303021	Grip, drive lever .....	2	42	800296	3/8-16 x 2 HH capscrew .....	1
7	324280	Latch w/grip (right) .....	1	43	804255	1/4-20 Nyloc nut .....	1
8	323229	Clip, 3/8 Loom (Kaw).....	2	44	413179	Tank, gas ..	1
9	303435	Washer, 1/4 disc spring .....	6	45	513508	Cap, fuel tank .....	1
10	323359	Linkage, wheel drive .....	2	46	808286	Clevis pin.....	2
11	804255	1/4-20 Nyloc nut .....	2	47	513645	Bushing, fuel tank.....	1
12	805256	1/4 STD. Flatwasher .....	1	48	543277	Elbow, 90° ..	1
13	800259	1/4-20 x 2 1/4 HH capscrew.....	2	49	303077	Clamp, fuel line (8.5 HP, B&S).....	4
14	323322	Throttle cable (Kaw. & Kohler) .....	1		303077	Clamp, fuel line (Kawasaki).....	5
	323552	Throttle cable (8.5 HP, B&S).....	1		303077	Clamp, fuel line (Kohler).....	6
15	513592	Knob, (red ball).....	1	50	800252	1/4-20 x 3/4 HH capscrew.....	1
16	303287	Plastic tie, 5 1/2" (Kaw) .....	5	51	323229	Clip, 3/8 Loom (Kohler & B&S).....	1
	303287	Plastic tie, 5 1/2" (Kohler & B&S) .....	3	52♦	323430	Interlock, OPC .....	1
17	804257	3/8-16 Nyloc nut .....	5	53	303197	Gas filter (Kawasaki & Kohler) .....	1
18	804252	10-24 Nyloc hex nut .....	2	54	603776	Fuel line, 2.5" (Kaw. & Kohler) .....	1
19	807513	10-24 x 1/2 Carriage bolt.....	2	55	543296	Grommet, .....	1
20	806003	Hairpin cotter.....	4	56	603770	Fuel valve .....	1
21	808250	3/16 x 1 3/4 Clevis pin.....	2	57	303308	Clamp, fuel line (Kawasaki).....	1
22	803001	3/16 Palnut.....	2	58	603955	Fuel line, 6" (8.5 HP, B&S) .....	2
23	806340	5/16 x 1 Rollpin .....	2	59	603955	Fuel line, 6" (Kaw. & Kohler) .....	1
24	303327	Washer, 3/8 disc spring .....	4	60	323511	Wiring harness (Kawasaki) .....	1
25♦♦	412185	Lever, OPC (RH).....	1		323512	Wiring harness (Kohler) .....	1
26♦	803322	5/16-24 Setscrew .....	2		323510	Wiring harness (8.5 HP, B&S).....	1
27♦♦	412183	Lever, OPC (LH) .....	1	61♦	633023	Stud, gas tank .....	2
28	800292	3/8-16 x 1 HH capscrew.....	4	62	633349	Spring, gas tank .....	2
29	303365	Nylon bushing.....	2	63	513051	Switch .....	1
30	322192	Connecting rod.....	1	64	633181	Plate, tapped .....	1
31	303471	Fuel line, 12" (14 HP Kawasaki).....	1	65	803028	Screw .....	2
32	303363	Actuator spring.....	1	66	805005	Washer Lock 5/16 .....	2
33	303022	Fuel line, 8.5" (12.5 HP Kawasaki).....	1	67	804256	Nut, Nyloc 5/16-18.....	2
34	603954	Fuel line, 13.75" (Kohler).....	1	68	800271	Screw, 5/16-18X3/4.....	2
35	303088	Cable clip .....	1	69	303335	Plastic tie, large .....	2
36	303160	Compression spring .....	1	70	323549	Spacer .....	4

♦ Use Pro-lock (Nut type) Part No. 840022 (.5 mm tube) on setscrew threads.

♦ Use Pro-lock (Retaining) on inside of OPC hub (See Operator's Manual) & on fuel tank studs

♦ OPC refers to Operator Presence Control.

\* Not illustrated.

NOTE: Use dielectric grease on all electrical connections.

Exmark black touch up spray paint - Gloss black

DECALS

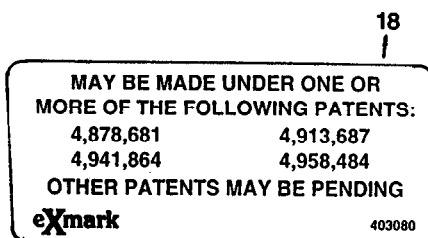
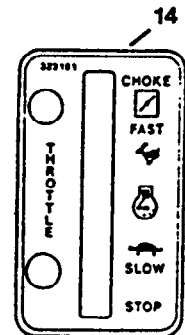
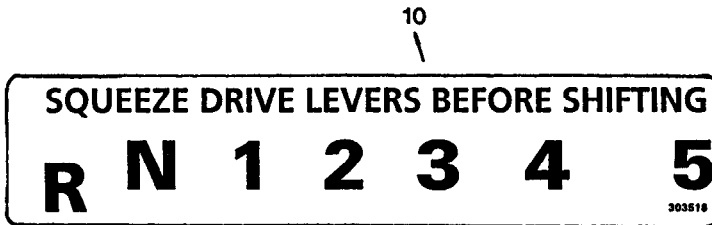
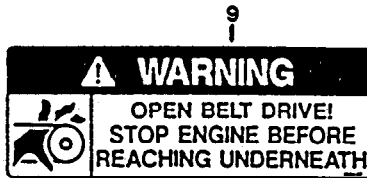
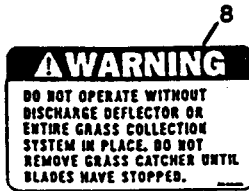
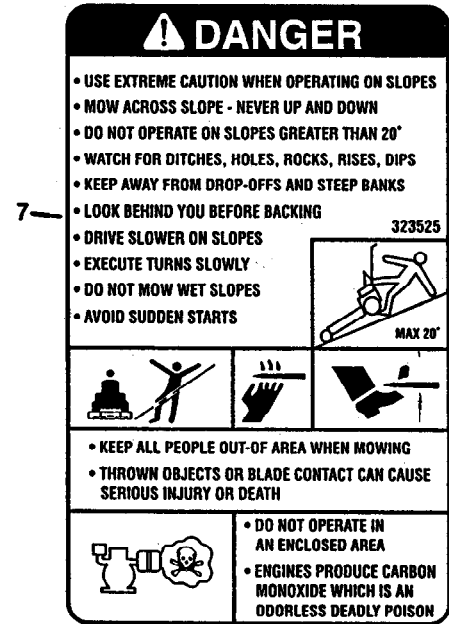
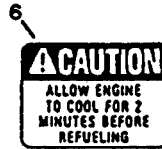
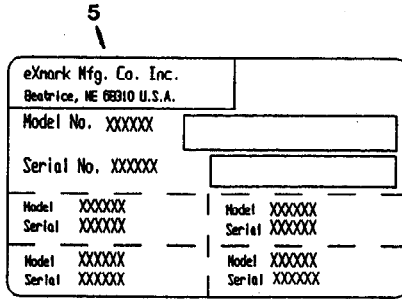
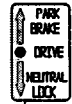
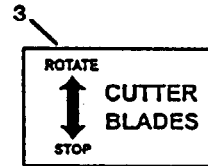

DECALS

19  
**COMMERCIAL 48**

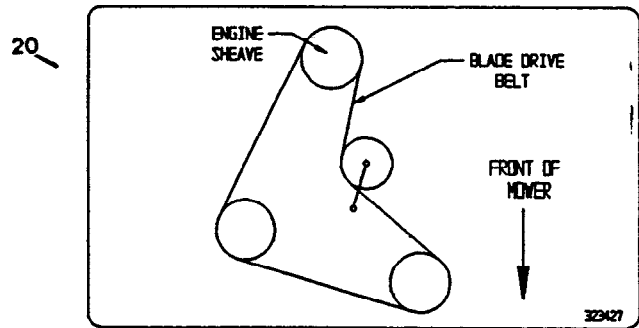
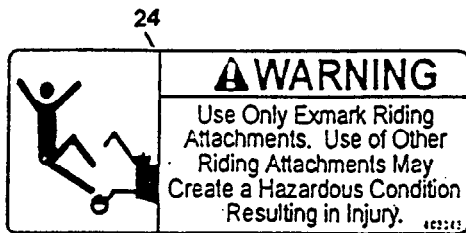
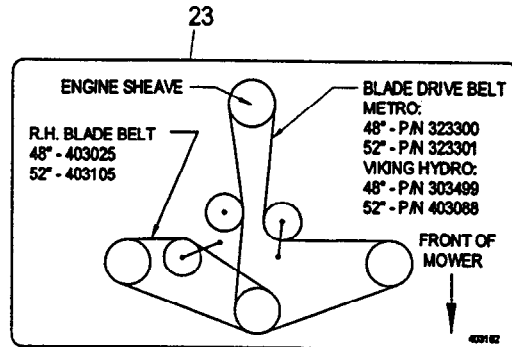
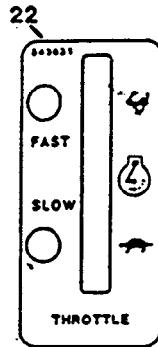

Ref. No.	Part No.	Description	Qty. Req'd.	Ref. No.	Part No.	Description	Qty. Req'd.
1	303001	Decal, Choke (B&S 8.5 hp).....	1	14	323151	Decal, Throttle/Choke (Kaw & Koh) ...	1
2	323554	Instruction Label .....	1	15	323411	Danger, Commercial 36" .....	1
3	303100	Decal, Cutter Blade.....	1	16	323412	Decal, Large Metro .....	1
4	323550	Decal, Neutral/Brake.....	2	17	403005	Danger, Label (48" & 52").....	2
5	303161	Serial No. Plate.....	1		403005	Danger, Label (32" & 36").....	1
6	303293	Decal, 2 Minute Cool .....	1	18	403080	Decal, Patent (32") .....	1
7	323525	Decal, Danger.....	1	19	403131	Decal, Commercial 48".....	1
8	303508	Decal, Discharge Warning.....	1	20	323427	Decal, Belt Routing (32" & 36") .....	1
9	303517	Decal, Belt Drive .....	1	21	513746	Decal, Muffler .....	1
10	303518	Decal, Shifter .....	1		513746	Decal, Muffler (32").....	2
11	303520	Decal, TriVantage.....	1	22	543631	Decal, Throttle (B&S 8.5 HP) .....	1
12	323410	Decal, Commercial 32" .....	1	23	403162	Decal, Belt Routing (48").....	1
13	323312	Decal, Small Metro .....	1	24	403143	Decal, Sulky Warning.....	1

# WIRING DIAGRAMS

## KAWASAKI & B&S 8.5 HP

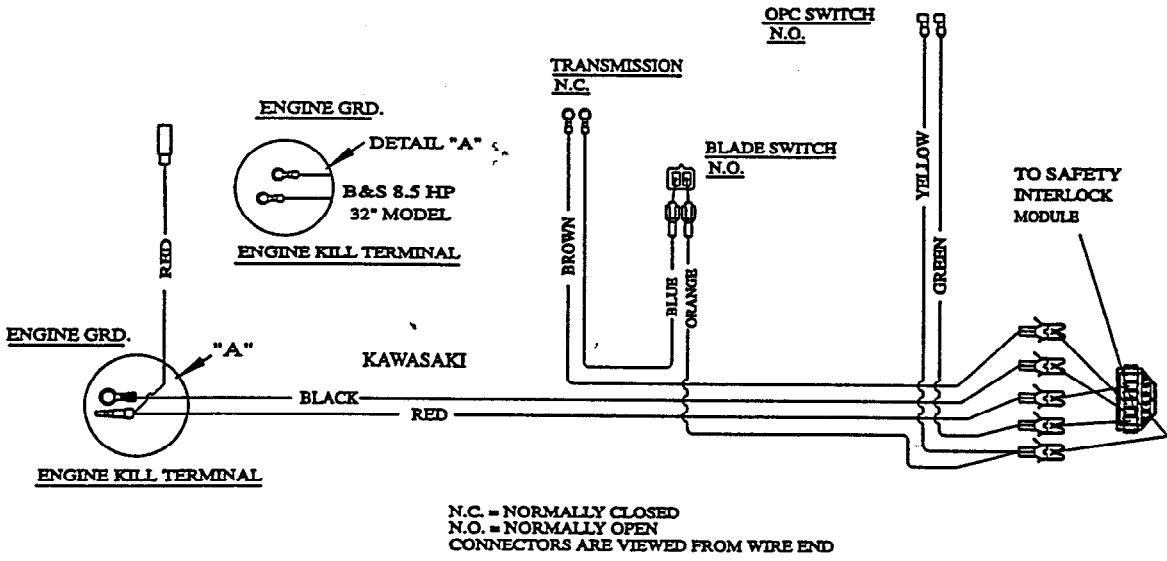

## KOHLER

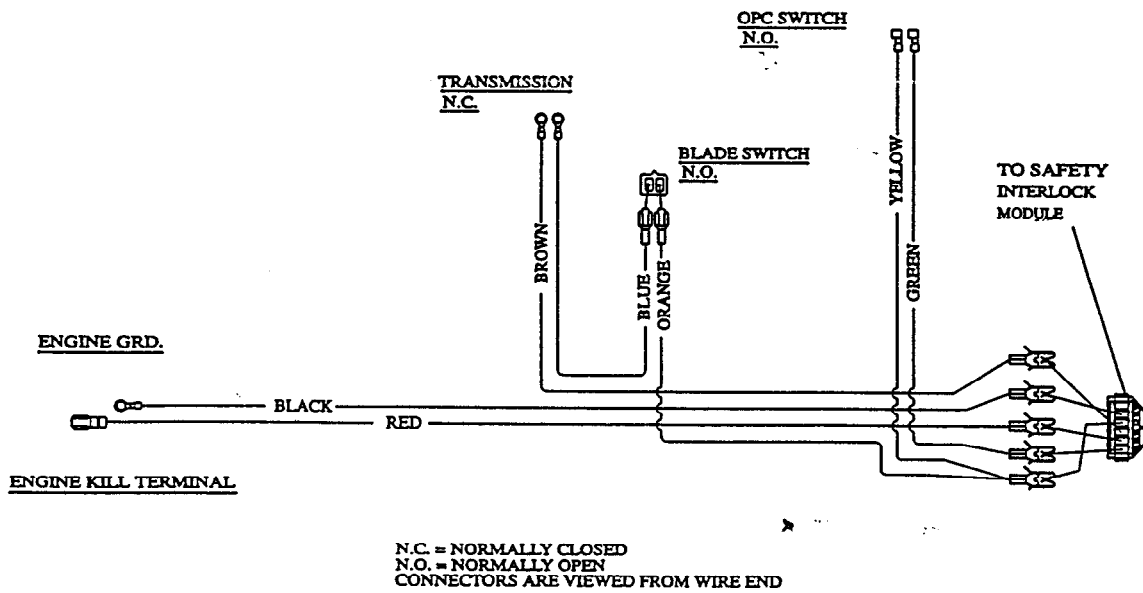





**SEE EXMARK'S COMPLETE  
LINE OF PRODUCTS FOR TURF CARE**

**LAZER Z**

**LAZER Z HP**

**EXPLORER**

**TURF RANGER**

**TURF TRACER**

**TURF TRACER HP**

**VIKING HYDRO**

**METRO**

**METRO HP**

**SELF STEERING SULKY**

**GRASS CATCHER**

**MICRO-MULCHING ACCESSORY**

**EXMARK MFG. CO. INC.  
INDUSTRIAL PARK BOX 808  
BEATRICE, NE. 68310**

**PART NO. 850515  
(402) 223-6300  
FAX (402) 223-6384**

**ALL RIGHTS RESERVED**

**PRINTED IN U.S.A.**

