

For Serial Nos.
510,000 & Higher

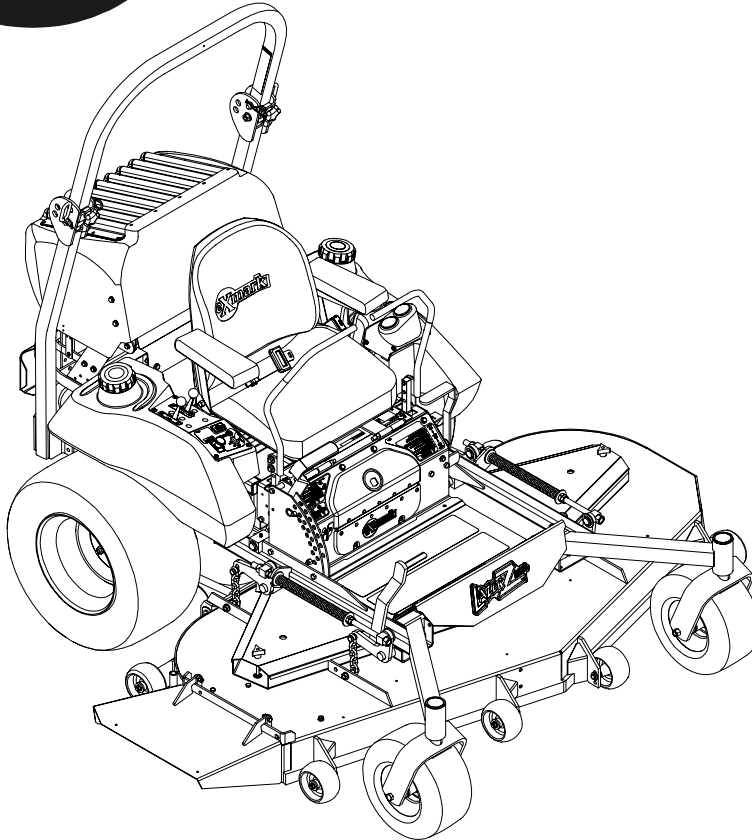

PARTS MANUAL

LAZER Z[®]

LIQUID-COOLED MODELS

CONGRATULATIONS on the purchase of your new Exmark mower. This product has been carefully designed and manufactured to give you a maximum amount of dependability and years of trouble-free operation. If additional information is needed, or should you require trained mechanic service, contact your authorized Exmark equipment dealer or distributor. If you need to order replacement parts from your dealer, always give the model number and serial number of your mower as well as the part number, description and quantity of the part needed.

The Serial No. plate is located on the right side of the console. For ease of ordering and reference, we suggest that you record the information requested in the following identification table.

Place Model No. and Serial No. Label Here (Included in Literature Pack) or Fill in Below
Model No. _____
Serial No. _____

Engine Model No. and Spec. No. (Code) _____

Engine Serial No. (E/No) _____

Date Purchased _____

EXMARK PARTS PLUS® PROGRAM

EFFECTIVE DATE: September 1, 1995

Program

If your Exmark dealer does not have the Exmark part in stock, Exmark will get the parts to the dealer the next business day or the part will be FREE* Guaranteed!!

How the Program Works

1. If dealer does not have part in stock for a "down" unit at the time of request by customer, the dealer contacts his distributor by 1:00 p.m., local time, and requests Exmark Parts Plus® shipment of six (6) line items or less.
2. Distributor ships part(s) to dealer or customer, as requested by dealer, same day, overnight UPS. Distributor bills dealer for part and freight charges where applicable.
3. If distributor does not have the part(s) in stock to satisfy Exmark Parts Plus® order, he contacts Exmark by 3:00 p.m., central time, with an Exmark Parts Plus® order of six (6) line items or less.
4. If order is received by 3:00 p.m. central time, Exmark ships part(s) direct to dealer or customer, as requested by distributor, same day, overnight UPS. Exmark bills the distributor for parts and shipping charges, where applicable.
5. The customer pays for the part and freight if it is shipped under the Exmark Parts Plus® and if it arrives in accordance to the program.
6. Who pays for the part and freight if it fails to arrive overnight in accordance to the program?
 - A. Under any circumstance the customer does not pay.
 - B. If the part does not arrive overnight due to:
 1. The dealer not submitting the Exmark Parts Plus® order to his Exmark distributor by 1:00 p.m., the dealer pays for the part and freight.
 2. The Distributor being unable to ship the part the same day or not submitting the Exmark Parts Plus® order to Exmark by 3:00 p.m., central time, the Distributor pays for the part and freight.
 3. Exmark being unable to ship the part and the Exmark parts order is received by 3:00 p.m., central time, Exmark pays for the part and freight.
 4. If the part does not arrive overnight due to the shipper (UPS), the shipper pays for the freight and Exmark pays for the part.

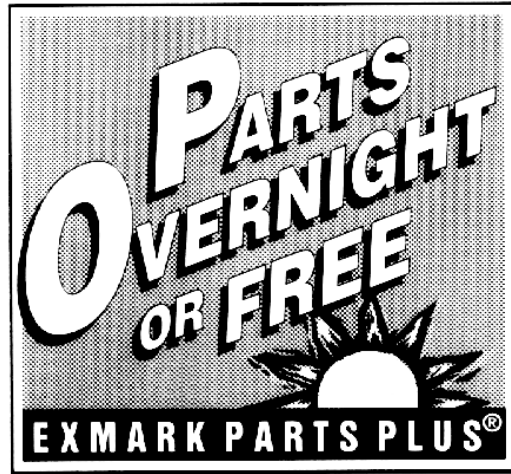

The following restrictions apply -- The Exmark Parts Plus® Program is available only through participating Exmark Dealers and applies only to orders submitted on this program Monday through Thursday. Parts Plus service is available only in the 48 contiguous United States. UPS has initiated a Saturday delivery program to many areas of the continental United States and can be requested for an overnight shipment on Friday to be delivered Saturday. The next day air charge, plus the Saturday delivery fee will be the responsibility of the purchaser. Exmark Mfg. will assume no responsibility for Saturday delivery shipments. To qualify, all Exmark Parts Plus® orders must be received by Exmark by 3:00 p.m., central time. Orders must be six (6) line items or less. Exclusions from the Exmark Parts Plus® Program are: Any wholegood or accessory in its entirety, engines and engine replacement parts, 5-speed Peerless transmissions and 5-speed transaxles, hydraulic or hydrostatic wheel motors, cutter decks and engine decks or any item exceeding United Parcel Service size and weight restrictions.

Due to UPS restrictions, aerosol spray paint is considered a hazardous material and cannot be shipped via UPS next day or Second Day Air.

Exmark Manufacturing stocks a limited supply of parts for transaxles, pumps and wheel motors. These parts can be ordered for Next Day Air shipment but will not be guaranteed per the Parts Plus Program.



**READ OPERATOR'S MANUAL BEFORE
OPERATING OR SERVICING EXMARK EQUIPMENT.**

TABLE OF CONTENTS

<u>Description</u>	<u>Page</u>
Decal Group.....	21-22
Electrical Diagrams	24
Electrical Groups.....	23
Electrical Logic Schematics.....	25
Engine Deck Group.....	14-18
Front Frame Group	7-8
Fuel Group.....	11
Hydraulics Group	19-20
Main Frame Group.....	9-10
Motion Control Group.....	13
Park Brake Group	12
60" Deck Group.....	3-4
72" Deck Group.....	5-6

60" DECK GROUP

Item	Part No.	Description	Qty.
1	103-3184	Asm, Deck (103-3029-01) W/Decals	1
2●	3217-46	Nut, Hex 3/4-16 Heavy	3
3	3256-24	Washer, 3/8 SAE	3
4	1-513208	Washer, Spring Disk	1
5	1-303334	Washer, 5/16 Spring Disk	1
6	32128-20	Nut, 5/16-18 Whizlock	8
7	1-602913-01	Baffle Wldmt, Discharge	1
8	322-2	Screw, 5/16-18 x 5/8	5
9★	1-603299	Roller, Antiscalp	6
10	3290-357	Nut, 3/8-16 Whizlock	2
11	1-373034	Washer, Pivot	8
12■	1-603602	Axle, Anti-Scalp Roller (Type A)	6
■	103-5364	Axle, Anti-Scalp Roller (Type B)	6
13	98-5975	Washer, 3/8 Spring Disk	13
14	98-5961	Screw, 3/8-16 x 4 Gr 8	1
15	103-5830-01	Chute, Discharge 60"	1
16	322-5	Screw, 5/16-18 x 1	4
17	3296-29	Nut, 5/16-18 Nyloc	4
18	1-633084-01	Shield, Belt 60"	2
19	1-323385	Knob, Belt Shield	6
20	1-322110	Belt Guide Wldmt	1
21	103-0862	Screw, 5/8-18 x 2 3/4 Gr 8	3
22	323-11	Screw, 3/8-16 x 2 1/4	2
23	1-303537	Stud, Belt Shield	2
24	3256-3	Washer 5/16 Std Flat	6
25	1-323417	Washer, Rubber	2
26	103-3330	Spring, Extension	1
27	322-6	Screw, 5/16-18 x 1 1/4	1
28	32120-10	Ring, Retaining	2
29✱	103-5693	Kit, Idler Arm (103-6528-01) W/Bearings	1
30	106-7159	O-ring	2
31	302-40	Zerk, 1/4-20 90°	1
32	3256-4	Washer, 3/8 Std Flat	2
33	3296-39	Nut, 3/8-16 Nyloc	19
34	103-3504	Bearing, Spherical	2
35	1-633109	Idler Pulley 6.00 Dia Flat	2
36	3234-11	Bolt, 3/8-16 x 1 Whizlock	1
37	1-633456	Bushing, Idler	2
38	323-8	Screw, 3/8-16 x 1 1/2	18
39	32128-37	Nut, 7/16-14 Whizlock	16

Item	Part No.	Description	Qty.
40	1-603805	Idler Pulley 5.06 O.D. V	1
41	1-633127	Belt, Blade Drive 60" Deck	1
42	1-633447	Chain	4
43	103-1898	Screw, 7/16-14 x 1 5/8 Sp	8
44	103-3505	Seal, Double, Lip	1
45	3217-11	Nut, 5/8-11 Hex	2
46	103-2802	Washer, Spring Disk	3
47*	103-8075	Cutter Housing Complete	3
48	323-6	Screw, 3/8-16 x 1	4
49	103-1072-01	Strut Wldmt, Deck	2
50+	103-2794	Sheave, Blade Drive	3
51	1-633029	Spherical Rod End	2
52	327-11	Screw, 5/8-11 x 5	2
53	3253-8	Lockwasher, 5/8 Reg. Spring	2
54	302-19	Zerk, 1/4-28 Straight	4
55	1-632199-01	Pin Wldmt, Deck Strut	2
56	3219-6	Nut, 5/8-18 Hex	3
57+	103-2785	Spindle	3
58+	103-3046	Sheave, Jackshaft Double	1
59	103-2982	Key, 1/4 x 3/16 x 3/4	3
60+	1-643393	Jackshaft	1
61+	103-1330	Guard, Bearing Top	3
62+	103-8280	Housing W/Bearings	3
63	103-0865	Washer, Spring Disk 5/8	3
64	103-2535	Spacer, Guard Bottom	4
65	103-2530	Blade, Notched	3
	103-2510	Blade, Low Lift	3
◆	103-0301	Blade, Mulching	3
	103-1580	Blade, Solid	3
	103-6338	Blade, Extreme	3
66	103-1081	Asm, Strut Long	2
67	103-3249	Jackshaft Assy	1
68+	103-2544	Asm, Jackshaft Housing W/Brgs	1
69▲	103-3258	Complete Deck Assy	1
70	103-2916	Guard, Top	1
71	103-5677	Spacer	1
72	103-3506	Seal, Single Lip	1
73■	3290-357	Nut, 3/8-16 (Type A) Whizlock	6
■	3296-39	Nut, 3/8-16 (Type B) Nyloc	6
74■	98-5961	Screw, 3/8-16 x 4 Gr8 (Type A)	6
■	3211-46	Screw, 3/8-24 x 2 Gr8 (Type B)	6

Exmark red touch up spray paint - P/N 1-850337.

- ◆ Requires installation of Micro-Mulch accessory for proper mulching. Mulch kit P/N MK604.
- Unit may have been built with Type A or Type B anti scalp axles. Reference page 4 to determine which axles are installed on the unit.
- ★ Kit 103-3168 includes antiscalp roller, axle, & mounting hardware for Type A axles. Kit 103-7263 includes antiscalp roller, axle, & mounting hardware for Type B axles.
- + Apply Mobil HTS grease (P/N 103-5217 1.5 oz packet) (or a food-grade antisieze) between the jackshaft and bearings, jackshaft and sheaves, spindles and bearings, spindles and sheaves, and under top bearing guard. DO NOT use a copper or nickel based antisieze.
- ▲ Complete deck assembly excludes items #39, #42, #43, and #66 and includes mule drive belt from page 18.
- * Complete cutter housing assembly also includes items #21 & #63.
- ✱ Kit also includes items #13 & #33.
- Use Pro-Lock, Nut Type (P/N 1-840022, .5ml tube) on nut Item #2.

60" DECK GROUP

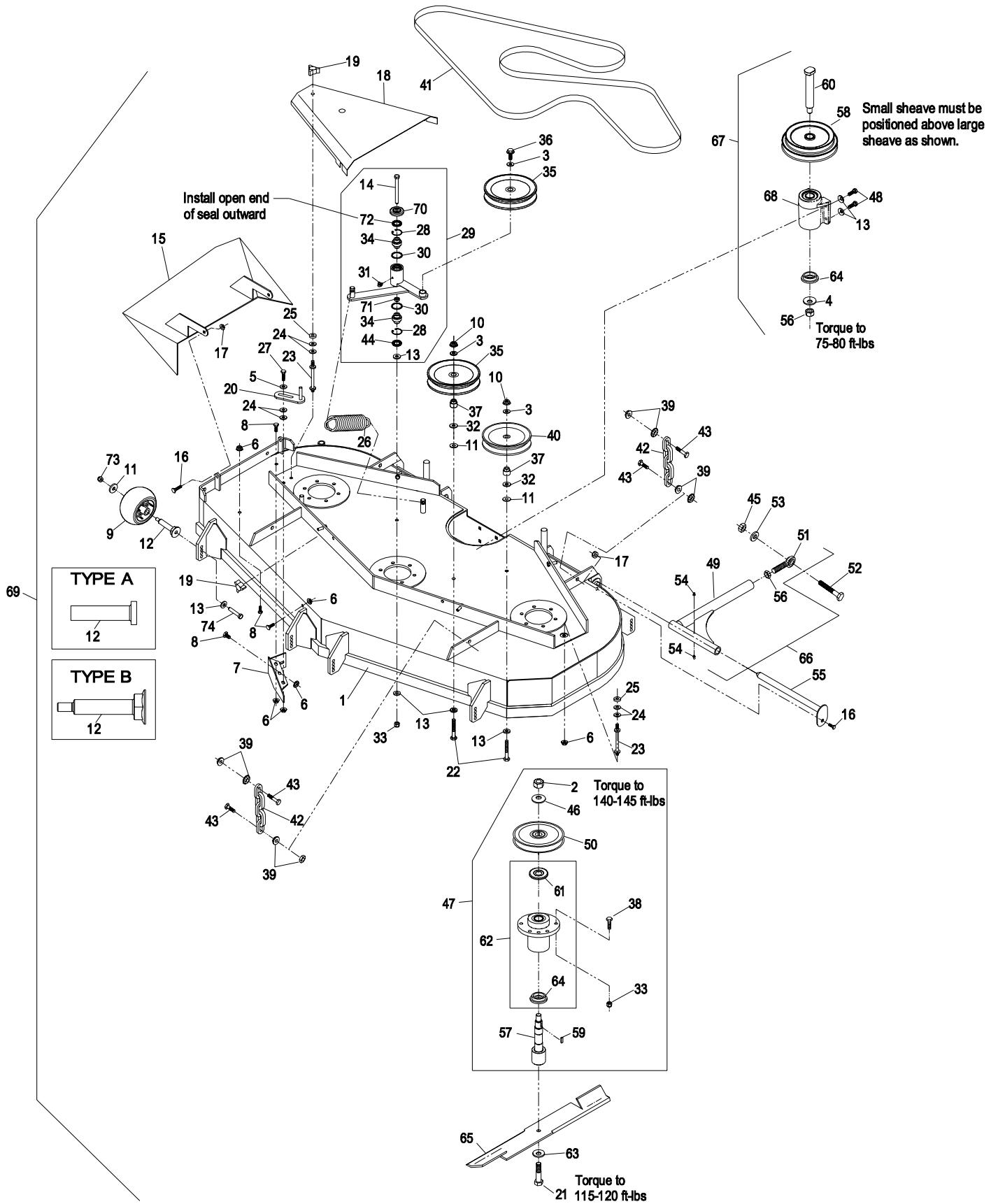

72" DECK GROUP

Item	Part No.	Description	Qty.
1	1-643052	Belt, Blade Drive 72"	1
2	1-323385	Knob, Belt Shield	6
3	1-643076-01	Shield, Belt 72" RH (Shown)	1
	1-643075-01	Shield, Belt 72" LH	1
4	3234-11	Bolt, 3/8-16 x 1 Whizlock	1
5	3256-24	Washer, 3/8 SAE	3
6	1-633109	Idler Pulley 6.00 Dia Flat	2
7	103-3330	Spring, Extension	1
8	3290-357	Nut, 3/8-16 Whizlock	2
9	1-633456	Bushing, Idler	2
10	3256-4	Washer, 3/8 Std Flat	2
11	1-373034	Washer, Pivot	8
12	3296-39	Nut, 3/8-16 Nyloc	19
13	32120-10	Ring, Retaining	2
14	1-513208	Washer, Spring, Disk	1
15	106-7159	O-ring	2
16	103-2802	Washer, Spring, Disk 3/4	3
17	3219-6	Nut, 5/8-18 Hex	3
18+	103-2544	Asm, Jackshaft Housing W/Brgs	1
19+	103-2795	Sheave, Blade Drive	3
20	1-303334	Washer, 5/16 Spring, Disk	1
21	1-322110	Belt Guide Wldmt	1
22*	103-5693	Kit, Idler Arm (103-6528-01) W/Bearings	1
23	32128-20	Nut, 5/16-18 Whizlock	8
24	323-6	Screw, .3/8-16 x 1	4
25	98-5975	Washer, 3/8 Spring, Disk	13
26	32128-37	Nut, 7/16-14 Whizlock	16
27	103-1898	Screw, 7/16-14 x 1-5/8	8
28	1-633447	Chain	4
29	3217-11	Nut, 5/8-11 Hex	2
30	3253-8	Lockwasher, 5/8 Reg.Spring	2
31	1-633029	Spherical Rod End	2
32	327-11	Screw, 5/8-11 x 5	2
33	103-1073-01	Strut Wldmt, Deck	2
34	1-632199-01	Pin Wldmt, Deck Strut	2
35	302-19	Zerk, 1/4-28 Straight	4
36	323-8	Screw, 3/8-16 x 1 1/2	18
37	1-323417	Washer, Rubber	2
38	3256-3	Washer 5/16 Std Flat	4
39	1-303537	Stud, Belt Shield	2

Item	Part No.	Description	Qty.
40	103-1591	Asm, Deck (103-3032-01) W/Decals	1
41●	3217-46	Nut, HH 3/4-16 Heavy	3
42	103-0865	Washer, Spring Disk 5/8	3
43	103-2982	Key, 1/4x3/16x3/4	3
44+	103-3046	Sheave, Double	1
45+	1-643393	Jackshaft	1
46	103-2535	Spacer, Guard Bottom	4
47+	103-1330	Guard, Bearing Top	3
48+	103-8280	Housing W/Bearings	3
49	103-2531	Blade, Notched	3
◆	103-2521	Blade, Mulching	3
	103-2511	Blade, Low Lift	3
	103-1581	Blade, Solid	3
	103-6339	Blade, Extreme	3
50	103-0862	Screw, 5/8-18 x 2 3/4 Gr 8	3
51	323-11	Screw, 3/8-16 x 2 1/4	2
52	103-3504	Bearing, Spherical	2
53	1-602913-01	Baffle Wldmt, Discharge	1
54	322-2	Screw, 5/16-18 x 5/8	5
55	98-5961	Screw, 3/8-16 x 4 Gr8	1
56■	1-603602	Axle, Anti-Scalp Roller (Type A)	6
■	103-5364	Axle, Anti-Scalp Roller (Type B)	6
57★	1-603299	Roller, Anti-Scalp	6
58	322-5	Screw, 5/16-18 x 1	5
59	1-642071-01	Chute, Discharge 72"	1
60	3296-29	Nut, 5/16-18 Nyloc	4
61	302-40	Zerk, 1/4-20 90°	1
62	1-603805	Idler Pulley 5.06 O.D. V	1
63+	103-2785	Spindle	3
64*	103-8323	Cutter Housing Complete	3
65	103-1083	Asm, Strut 72" Long	2
66	103-3249	Jackshaft Assy	1
67▲	103-3259	Complete Deck Asm	1
68	103-3505	Seal, Double, Lip	1
69	103-2916	Guard, Top	1
70	103-5677	Spacer	1
71	103-3506	Seal, Single Lip	1
72■	3290-357	Nut, 3/8-16 Whizlock (Type A)	6
■	3296-39	Nut, 3/8-16 Nyloc (Type B)	6
73■	98-5961	Screw, 3/8-16 x 4 Gr8 (Type A)	6
■	3211-46	Screw, 3/8-24 x 2 Gr8 (Type B)	6

Exmark red touch up spray paint - P/N 1-850337.

- ◆ Requires installation of Micro-Mulch accessory for proper mulching. Mulch kit P/N MK724.
- Unit may have been built with Type A or Type B anti scalp axles. Reference page 6 to determine which axles are installed on the unit.
- ★ Kit 103-3168 includes antiscalp roller, axle, & mounting hardware for Type A axles. Kit 103-7263 includes antiscalp roller, axle, & mounting hardware for Type B axles.
- + Apply Mobil HTS grease (P/N 103-5217 1.5 oz packet) (or a food-grade antisieze) between the jackshaft and bearings, jackshaft and sheaves, spindles and bearings, spindles and sheaves, and under top bearing guard. DO NOT use a copper or nickel based antisieze.
- ▲ Complete deck assembly excludes items #26, #27, #28, and #65 and includes mule drive belt from page 18.
- * Complete cutter housing assembly also includes items #42 & #50.
- ✘ Kit also includes items #12 & #25.
- Use Pro-Lock, Nut Type (P/N 1-840022, .5ml tube) on nut Item #41.

72" DECK GROUP

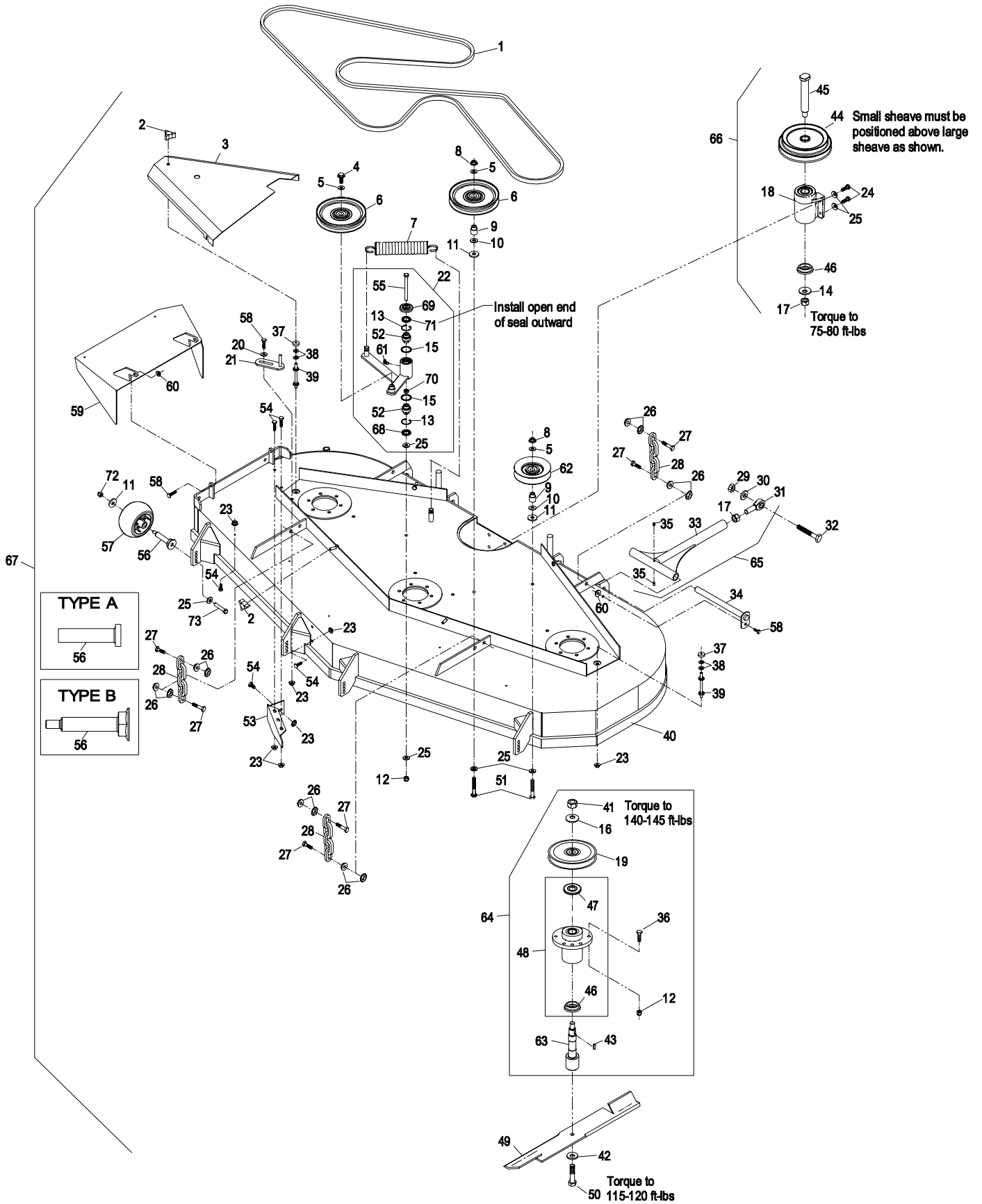

FRONT FRAME GROUP

Item	Part No.	Description	Qty.
1▲	103-5474	Asm, Front Frame, 60".....	1
▲	103-5475	Asm, Front Frame, 72".....	1
2	302-19	Zerk, 1/4-28 Straight.....	5
3	106-6572	Pad, Antiskid.....	2
4	1-633553	Pad, Anti Skid.....	2
5	103-2084	Asm, Lever(103-2083-03)W/Grip.....	1
6	1-633295	Grip, Lift Lever.....	1
7	103-2064-03	Arm Wldmt, Deck Lift.....	1
8	1-633325	Spring, Compression.....	1
9	3256-24	Washer, 3/8 SAE Flat.....	1
10	3296-39	Nut, Nyloc 3/8-16.....	5
11	32151-103	E-Ring.....	5
12	1-633068	Arm, Deck Lift.....	2
13	1-633889-01	Plate, Deck Lift.....	1
14	1-632899-01	Plate Wldmt, Deck Lift.....	1
15	1-633082	Bushing, Lift Lever.....	1
16	1-633080	Bushing, Lift Lever.....	1
17	323-13	Screw, 3/8-16 x 2 3/4.....	1
18	1-633097	Hitch Pin W/Lanyard.....	1
19	1-806005	Hairpin Cotter.....	1
20	323-9	Screw, 3/8-16 x 1 3/4.....	2
21	98-5975	Washer, 3/8 Disc Spring.....	12
22	3290-357	Nut, Whizlock 3/8-16.....	15
23	323-6	Screw, 3/8-16 x 1.....	1
24	323-7	Screw, 3/8-16x1 1/4.....	12
25	3256-29	Washer, 7/8 SAE Flat.....	4
26	1-633096	Rod, Deck Lift.....	2
27	3217-11	Nut, 5/8-11 Regular (60").....	8
	3217-11	Nut, 5/8-11 Regular (72").....	6
28	1-633441	Swivel, Deck Mount.....	4
29	3256-7	Washer, 5/8 Std Flat.....	4
30	1-633064	Spring, Deck Support (60").....	2
	1-643015	Spring, Deck Support (72").....	2
31	103-4882	Cap, Grease.....	2

Item	Part No.	Description	Qty.
32	3218-6	Jam Nut, 5/8-11 (60").....	4
	3218-6	Jam Nut, 5/8-11 (72").....	6
33	103-3528	Asm, Floorpan (103-3241-01) W/Pads & Decals.....	1
34	1-543511	Seal, Grease.....	2
35	103-1474-01	Caster Wldmt.....	2
36	3296-51	Nut, 3/4-10 Nyloc.....	2
37	1-633508	Washer, Spring Disk.....	6
38	325-39	Screw, 1/2-13 x 9 1/2.....	2
39	1-811010	Plug.....	2
40	103-2768	Guard, Seal.....	4
41	3296-23	Nut, 1/2-13 Nyloc.....	2
42	3230-1	Bolt, Carriage 5/16-18 x 3/4.....	4
43	103-0063	Seal, Bearing.....	4
44	1-633585	Bearing Cone.....	4
45	32128-20	Nut, Whizlock 5/16-18.....	4
46	103-5156	Axle, Caster.....	2
47	103-1918	Bushing.....	2
48	323-29	Screw, 3/8-16 x 1 3/8.....	2
49	32151-29	Ring, Retaining.....	2
50	3274-18	Screw, Socket HD 5/16-18x1 1/4.....	2
51	1-543508	Bearing Cup, Tapered Roller.....	4
52+	103-3051	Spacer, Nut.....	4
53	103-3799	Asm, Caster Wheel.....	2
54	3218-2	Jam Nut, 5/16-18.....	2
55	103-1955-01	Weldmt, Front Lift Shaft (LH).....	1
56	103-2013-01	Weldmt, Front Lift W/Lever(RH).....	1
57	1-523157	Washer, Spacer.....	2
58	1-634439	Asm, Deck Lift Spring (60").....	2
	103-2047	Asm, Deck Lift Spring (72").....	2
59	103-3527	Asm, Floorpan (103-3242-01) W/Pads & Decals.....	1
60	1-543509	Bearing Cone, Tapered Roller.....	4

Exmark red touch up spray paint - P/N 1-850337.

✚ Use Pro-Lock, Nut Type (P/N 1-840022, .5ml tube) on spacer nut, Item #52.

▲ Includes frame weldment plus items #31, #34, #39, #49, #51, #55, #56, and #57.

FRONT FRAME GROUP

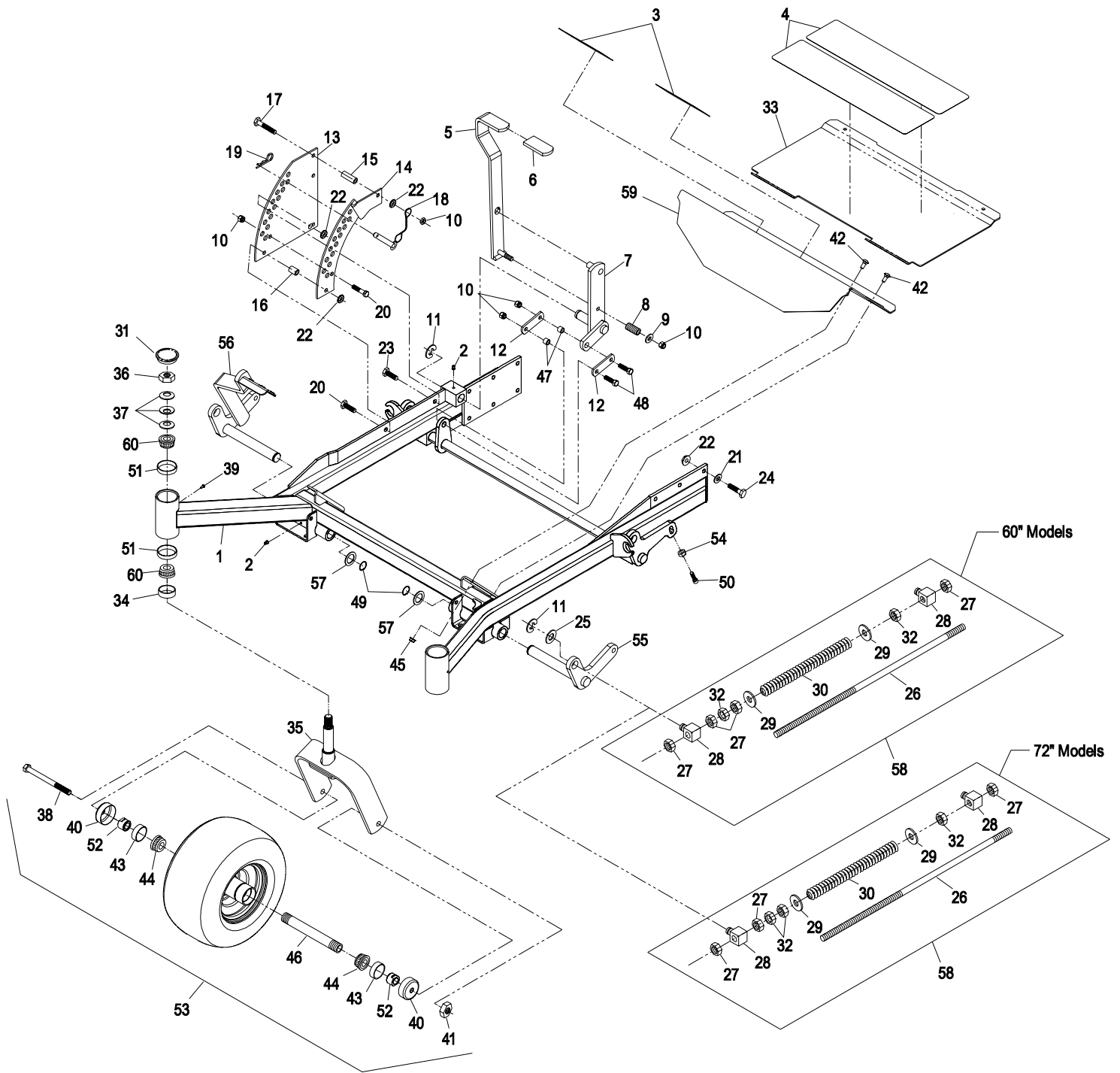

MAINFRAME GROUP

Item	Part No.	Description	Qty.
1	1-643255	Track, Seat (4" Adjustable).....	1
	103-8386	Spring, Seat Rail	1
2●	103-3524	Seat	1
3	1-543401	Spacer, Seat Track	2
4	322-3	Screw, 5/16-18 x 3/4	6
5	103-3521	Cushion, Seat	1
6	103-3520	Cushion, Backrest.....	1
7	103-0292	Cushion, Armrest (RH).....	1
8*	103-0291	Cushion Armrest (LH)	1
9	1-633859	Seat Frame	1
10	3256-3	Washer, 5/16 Std Flat	2
11	103-7617	Asm, Frame (103-8447-03) W/Decals	1
12	103-2743	Wheel/Tire Assy.....	2
	103-2744	Tire, 24x12-12 4 Ply	2
	1-633992	Wheel	2
13	103-5254	Asm, Console (103-3665-03) W/Decals .	1
14	103-4423	Asm, Seat Frame	1
15	242-50	Nut, Wheel 1/2-20	8
16	1-633293	Rod, Seat Hold-Up.....	1
17	322-5	Screw, 5/16-18 x 1	1
18	323-39	Screw, 3/8-16 x 5	2
19	3296-2	Nut, Nyloc #10-24	8
20	3296-29	Nut, Nyloc 5/16-18	5
21	3296-39	Nut, Nyloc 3/8-16	3
22	3290-357	Nut, Whizlock 3/8-16.....	10
23	32128-20	Nut, Whizlock 5/16-18	8
24	323-20	Screw, 3/8-16 x 3-1/4	1
25	3256-24	Washer, 3/8 SAE Flat.....	1
26	107-3155	Cotter, Hair Pin Double Loop	2
27	107-3083	Latch, Seat.....	1
28	322-4	Screw 5/16-18 x 7/8	2

Item	Part No.	Description	Qty.
29	1-513658	Bumper.....	2
30	3256-23	Washer, 5/16 SAE Flat	10
31	103-4434	Grip	1
32	323-6	Screw, 3/8-16 x 1	2
33	1-633964-03	Stop, Park Brake.....	1
34	1-633872-03	Stop/Spacer.....	2
35	103-0284	Tab, Armrest Adjustment	2
36	322-7	Screw, 5/16-18 x 1 1/2.....	2
37	1-633349	Spring, Compression	2
38	3212-4	Screw, 7/16-20 x 1.00	2
39	3296-38	Nut, Nyloc 7/16-20	2
40	103-4469	Kit, Seat Belt.....	1
41	107-0075	Bushing	1
42	107-0076	Spring.....	1
43	107-3058	Catch, Seat Latch	1
44	3256-14	Washer, #10 STD Flat	8
45	32122-28	Screw, Truss HD #10-24 x 1	4
46	1-803075	Screw, Truss HD #10-24 x 3/4	2
47	3290-500	Screw, Pan Head #10-24 x 5/8	2
48	103-3790	Latch, Cubby Door.....	1
49	103-3666	Asm, Cubby	1
50	323-6	Screw, Hex Cap 3/8 x 1	8
51	107-3154	Nut, Push 3/8-16.....	2
52	98-5975	Washer, Spring Disk 3/8	8
53	106-0887	Knob.....	2
54	32128-23	Nut, Hex Flange Side Lock 1/2-13	2
55	325-13	Screw, 1/2-13 x 3 1/4.....	2
56■	103-4553	Asm, ROPS Fold Pin	2
57	107-3124	Clip	2
58	103-8383	Bolt, Seat Cushion	5
59◆	103-8436	Kit, XP ROPS Service.....	1

Exmark black touch up spray paint - gloss black.

* Not illustrated.

■ Includes ROPS fold pin plus hairpin, item #26.

◆ Rollover protection is serviced as a complete assembly only. Includes complete ROPS frame, mounting hardware, fold pivot and locking hardware, seat frame assembly item #14, catch item #43, and seat belt assembly item #40.

● Includes armrests, armrest adjuster hardware and seat back decal. Does not include seat belt or tracks.

MAINFRAME GROUP

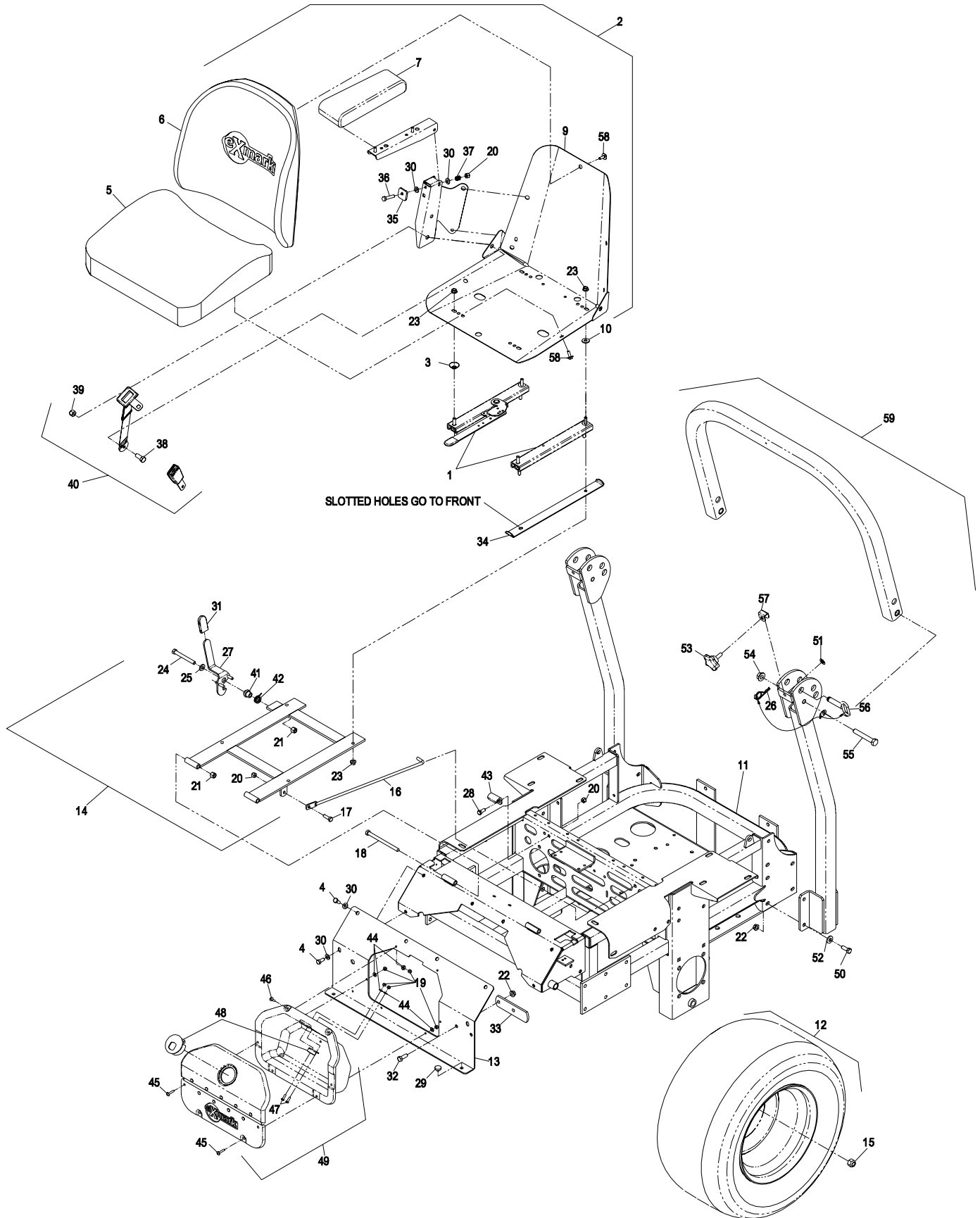

FUEL GROUP

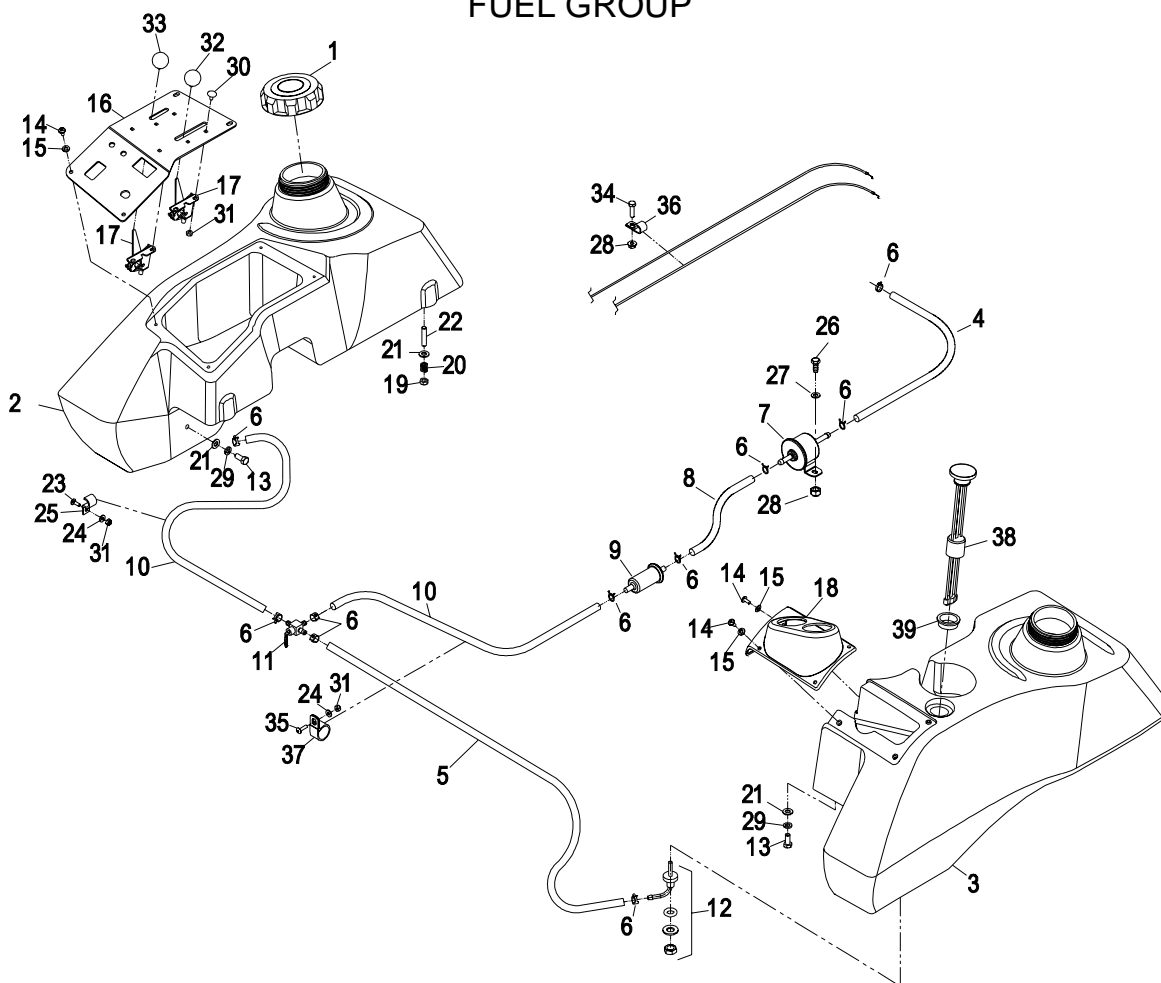

Item	Part No.	Description	Qty.
1	103-3536	Cap, Fuel Tank	2
2*	103-4925	Asm, Tank Fuel (RH)	1
3*	103-4926	Asm, Tank Fuel (LH)	1
4	103-1335	Fuel, Line	1
5	103-1419	Fuel Line	1
6	1-303077	Clamp, Fuel Line.....	10
7+	Kawasaki	P/N 49040-2065 Fuel Pump.....	1
8	1-643270	Fuel Line.....	1
9+	Kawasaki	P/N 49019-1055 Fuel Filter	1
10	1-543526	Fuel Line.....	2
11	1-633347	Valve, Fuel.....	1
12●	103-2605	Fitting, Fuel Blkhd W/Screen.....	2
	103-2784	O-Ring.....	2
	322-3	Screw, 5/16-18 X 3/4.....	4
14■	32122-30	Screw, Phillips Truss HD #10-24 X 1/2...8	
15	1-303435	Washer, Disc Spring 1/4.....	8
16	103-5252	Asm, Control Panel W/Decals	1
17	103-4091	Cable, Throttle	2
18	103-3684	Bezel, Gauge.....	1
19	3296-47	Nut, Thin Nyloc 5/16-18.....	6

Item	Part No.	Description	Qty.
20	1-633349	Spring, Fuel Tank	6
21	3256-23	Washer, 5/16 SAE	10
22◆	1-633023	Stud, Fuel Tank	6
23	1-807533	Bolt, Carriage #10-24 X 5/8.....	1
24	3256-14	Washer, Flat #10	2
25	103-1193	Clip, Loom Half	1
26	321-4	Screw, Cap 1/4-20x3/4	2
27	3256-22	Washer, Flat SAE 1/4	2
28	32128-33	Nut, Whizlock 1/4-20.....	3
29	1-805005	Washer, Lock 5/16.....	4
30	1-807513	Bolt, Carriage #10-24 X 1/2.....	4
31	3296-2	Nut, Nyloc #10-24	6
32	1-513592	Knob, Red (Throttle)	1
33	1-513593	Knob, Black (Choke).....	1
34	321-6	Screw, 1/4-20 X 1	1
35	1-803075	Screw, Truss HD #10-24 X 3/4.....	1
36	1-513762	Clip, Loom (.50).....	1
37	1-643312	Clip, Loom	1
38	99-7262	Gage, Fuel.....	1
39	95-8972	Grommet	1

➤ Refer to Engine Owner's Manual (Fuel Filter **Must** be 40 Micron or smaller).

● Use Pro-lock, Nut type (Part No. 1-840022), .5ml tube on fuel fitting.

◆ Use Pro-lock, Retaining Type (Part No. 1-840023), .5cc tube on stud threads going into the tank.

* Includes: tank, cap, fitting & studs. LH tank also includes fuel gauge.

■ Snug fit only on slotted holes, **Do Not Overtighten**, tank must be able to expand.

PARK BRAKE GROUP

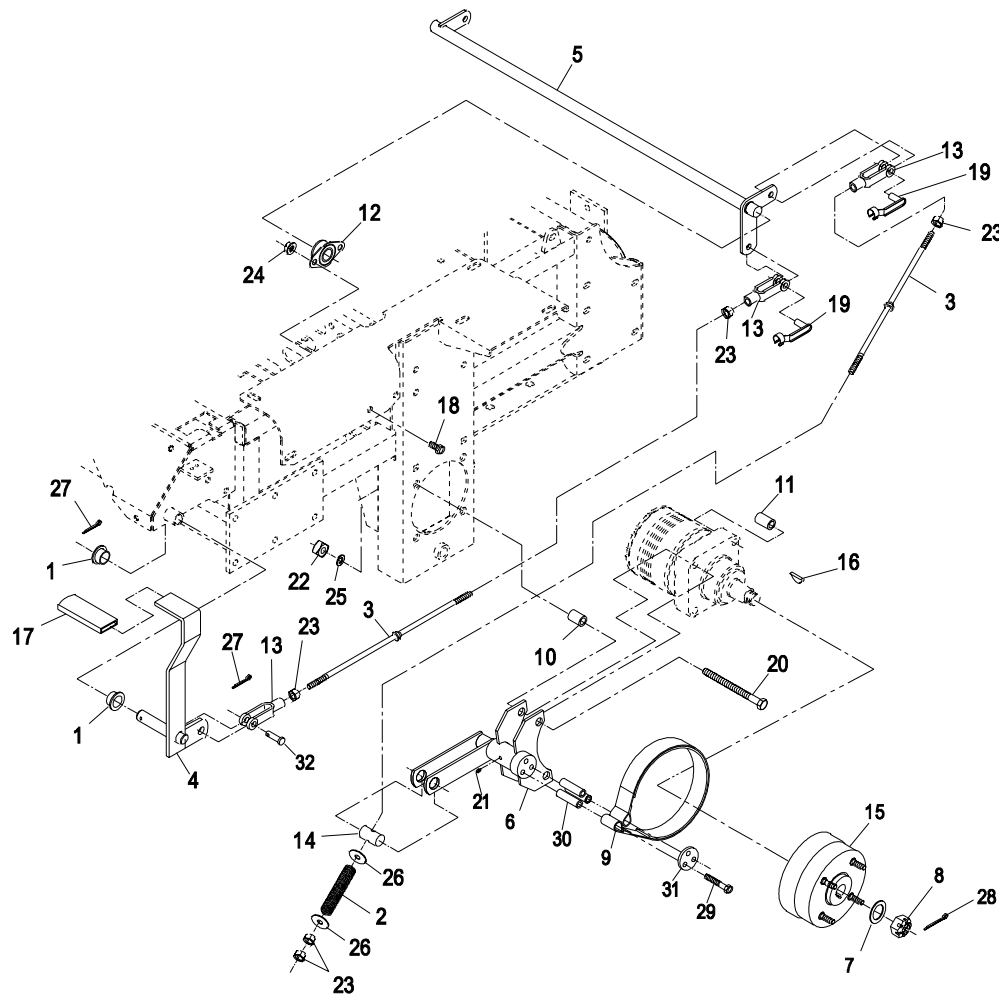

Item	Part No.	Description	Qty.
1	1-513140	Bushing.....	2
2	1-633454	Spring, Brake Rod.....	2
3	1-633477	Rod, Brake.....	3
4	1-634500	Lever (1-632489-03)W/Grip	1
5	1-632217-03	Shaft, Brake	1
6	103-0352-03	Bracket, Brake (60").....	2
	103-0354-03	Bracket, Brake (72").....	2
7	1-523157	Washer, Spacer	2
8	1-809036	Nut, Slotted 1.00-20	2
9	103-0355	Band, Brake	2
10	103-6594	Spacer (Short)(60")	4
*	1-633060	Spacer (Short) (72")	4
11	1-653381	Spacer (Long)(60").....	4
*	1-633062	Spacer (Long)(72").....	4
12	1-633102	Bearing, Flange.....	2
13	1-633131	Yoke	4
14	1-633144	Pin, Trunion	2
15	103-0590	Hub & Drum W/Studs, Wheel.....	2
*	1-633926	Studs, Wheel	8
16	3257-42	Key, Woodruff 5/16 x 1.....	2

Item	Part No.	Description	Qty.
17	1-633268	Grip, Brake Lever.....	1
18	323-4	Screw, 3/8-16 x 3/4.....	4
19	103-2399	Pin, Clevis Spring 3/8.....	3
20	325-17	Screw, 1/2-13 x 4 (60")	8
	325-20	Screw, 1/2-13 x 6 (72")	8
21	1481	Zerk, 1/4-28 45° (60").....	2
	302-19	Zerk, 1/4-28 Straight (72").....	2
22	103-0131	Nut, Sq. Reg. 1/2-13 UNC-2B	8
◆	32128-49	Nut, Whizlock 1/2-13 (72")	8
23	3219-3	Nut, 3/8-24.....	8
24	3290-357	Nut, Whizlock 3/8-16.....	4
25	3253-7	Washer, Lock 1/2.....	8
26	3256-4	Washer, 3/8 Std.....	4
27	3272-10	Pin, Cotter 1/8 x 3/4	2
28	1-806800	Pin, Cotter 9/64 x 1 1/2	2
29	322-9	Screw, 5/16-18 x 1 3/4	6
30	103-0384	Spacer.....	6
31	103-0374	Retainer, Brake Band.....	2
32	1-808285	Pin, Clevis 3/8 x 1 1/4	1

Exmark black touch up spray paint - gloss black.

* Not Illustrated.

□ This component is required for all 52" & 60" units and 72" units with S/N 498,999 and lower.

◆ This component is required for all 72" units with S/N 499,000 and higher.

MOTION CONTROL GROUP

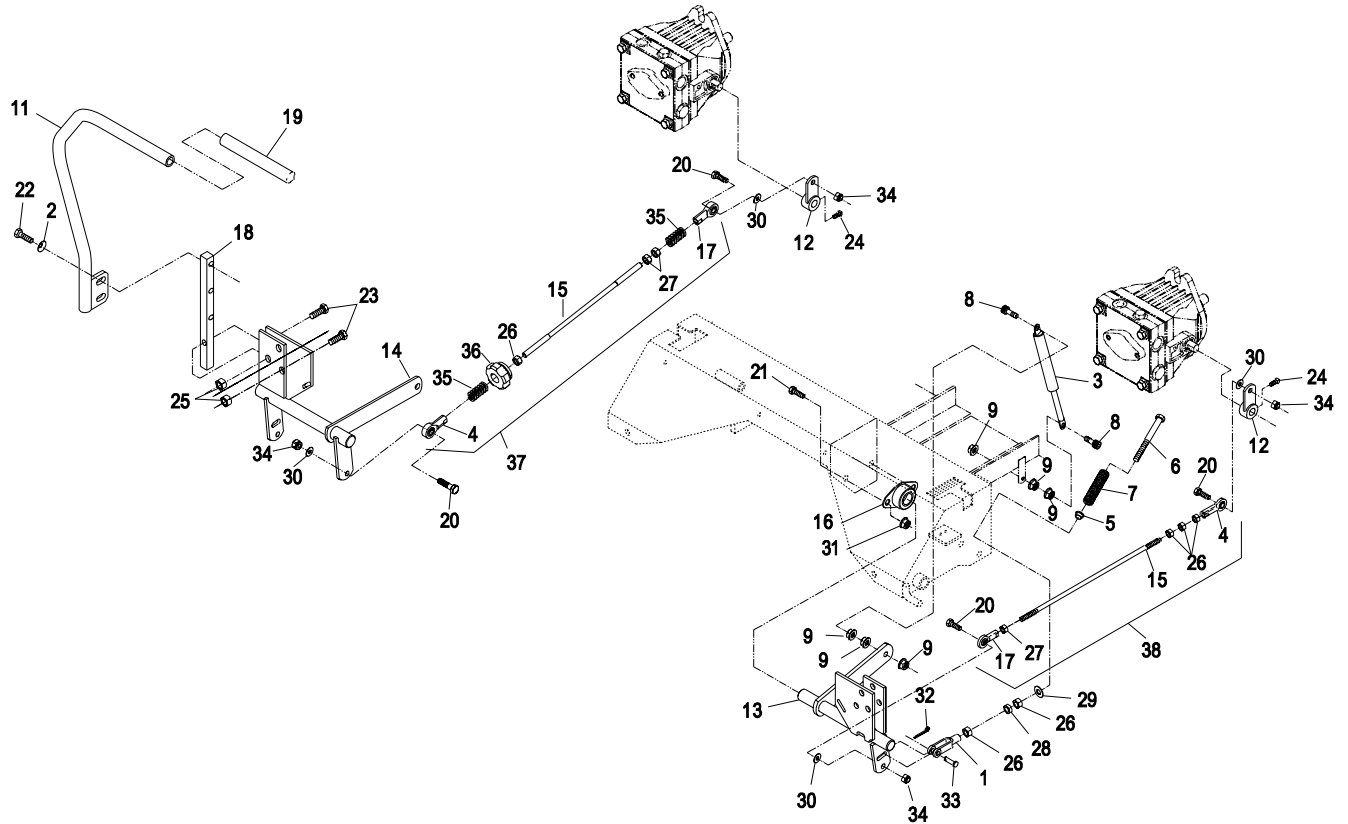

Item	Part No.	Description	Qty.
1	1-303105	Yoke	2
2	98-5975	Washer, Disc Spring 3/8.....	4
3	103-4079	Damper.....	2
4	1-543017	Ball Joint (RH).....	2
5	1-603735	Bushing, Nylon (Reverse Ind).....	2
6	1-603737	Bolt, (Neutral Return)	2
7	1-603807	Spring, (Neutral Return)	2
8	1-403180	Screw, 5/16-18x1 3/8 Sp.....	4
9	32128-20	Nut, Whizlock 5/16-18	12
10*	103-3457	Handle (103-3326-03) W/Grip (LH)	1
11	103-3458	Handle (103-3327-03) W/Grip (RH).....	1
12	1-632208	Arm, Pump Control.....	2
13	103-4781	Bracket, Motion Control (LH).....	1
14	103-4782	Bracket, Motion Control (RH)	1
15	103-3064	Link, Tracking Rod	2
16	1-633102	Bearing, Flanged.....	4
17	1-633152	Ball Joint (LH)	2
18	103-0407	Arm, Control Shaft.....	2
19	103-3456	Grip, Motion Control Handle	2

Item	Part No.	Description	Qty.
20	322-6	Screw, 5/16-18 x 1 1/4	4
21	323-4	Screw, 3/8-16 x 3/4.....	8
22	323-7	Screw, 3/8-16 x 1	4
23	323-9	Screw, 3/8-16 x 1 3/4	6
24+	1-803022	Set Screw, 5/16 x 5/8.....	2
25	3296-39	Nut, Nyloc 3/8-16.....	6
26	3219-2	Nut, 5/16-24	8
27	1-804524	Nut, 5/16-24 (LH)	3
28	3220-2	Nut, Jam 5/16-24	2
29	3256-2	Washer, 1/4	2
30	3256-3	Washer, 5/16 Std.....	4
31	3290-357	Nut, Whizlock 3/8-16.....	8
32	3272-5	Pin, Cotter 3/32 x 1/2	2
33	1-808280	Pin, Clevis 5/16 x 1	2
34	3296-29	Nut, Nyloc 5/16-18.....	4
35	1-323245	Spring, Compression	2
36	103-3060	Knob, Tracking.....	1
37	103-4330	Asm, Tracking Rod	1
38	103-4331	Asm, Tracking Rod	1

Exmark black touch up spray paint - gloss black.

* Not Illustrated.

+ Use Pro-lock, Nut type (Part No. 1-840022), .5ml tube on setscrews.

ENGINE DECK GROUP

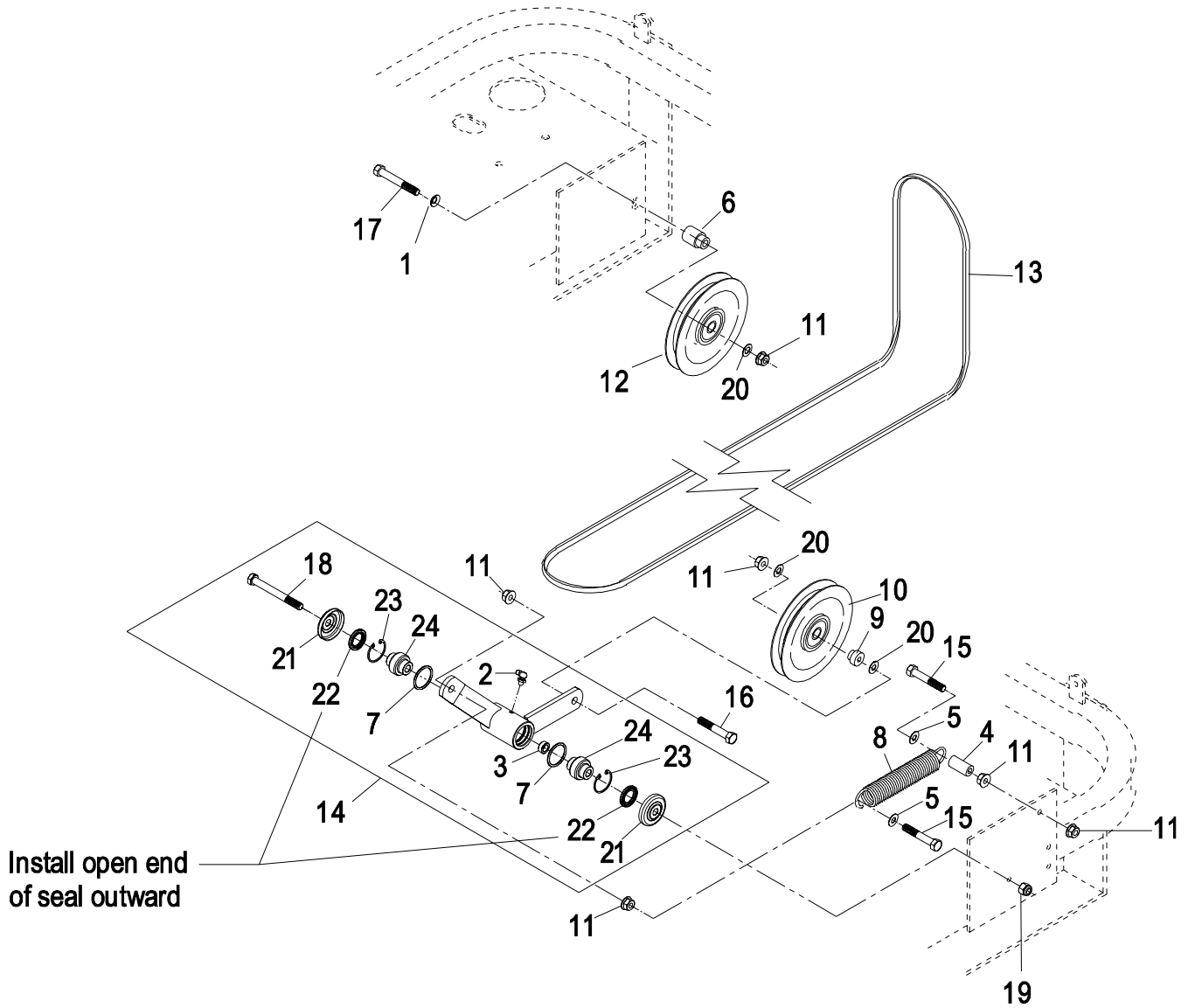

Item	Part No.	Description	Qty.
1	98-5975	Washer, Spring Disc 3/8.....	1
2	302-40	Zerk, 1/4-20 (90°).....	1
3	103-5677	Spacer	1
4	1-603401	Spacer, Spring	1
5	3256-4	Washer, 3/8 Std	2
6	103-2627	Bushing, Idler	1
7	106-7159	O-ring.....	2
8	1-603402	Spring, Mule Idler.....	1
9	1-603496	Bushing, Idler	1
10	1-603805	Pulley, Idler	1
11	3290-357	Nut, Whizlock 3/8-16.....	6
12	1-633166	Pulley, Idler	1
13	103-4014	Belt, Mule Drive.....	1

Item	Part No.	Description	Qty.
14*	103-5695	Kit, Idler Arm (103-4593-03) W/Bearings.....	1
15	323-11	Screw, 3/8-16 x 2 1/4	2
16	323-9	Screw, 3/8-16 x 1 3/4	1
17	323-13	Screw, 3/8-16 x 2 3/4	1
18	1-800805	Screw, 3/8-16 x 3 1/2 Gr8	1
19	3296-39	Nut, Nyloc 3/8	1
20	3256-24	Washer, 3/8 SAE	3
21	103-2916	Guard, Top	2
22	103-3506	Seal, Single Lip.....	2
23	32120-10	Ring, Retaining	2
24	103-3504	Bearing, Spherical	2

Exmark black touch up spray paint - gloss black.

* Kit also includes item #19.

ENGINE DECK GROUP (cont.)

Item	Part No.	Description	Qty.
1	103-3342	Asm, Radiator Trim (1-633902-03) W/Decals	1
2	1-643161	Cap, Radiator.....	1
3	103-1046	Radiator, Horiz. Mount	1
4	322-1	5/16-18 x 1/2 HHC Screw.....	12
5	3256-23	Washer, Flat SAE 5/16.....	14
6	103-3343	Asm, Fan Mount Plate (1-633888-03) W/Decals	1
7	1-803067	Screw, 12-24 x1 HSWHMach	4
8	3256-16	Washer, Flat Std #12	8
9	1-804254	Nut, Nyloc HH #12-24	4
10	1-633831	Fan Assy, 12" Hi Profile	1
11	1-633989	Clamp, Hose-Worm .75-1.50.....	4
12	103-0074	Hose, Radiator Inlet	1
13	103-0075	Hose, Rad. Outlet	1
14	103-1557	Muffler, Kit.....	1
15	321-3	Screw, Cap HH 1/4 x 20-.625.....	1
16	98-5975	Washer, Disc Spring 3/8.....	6
17	1-633988	Spacer, Clutch Anchor	1
18	1-633396	Clip, Loom .56.....	1
19	93-2195	Element, Filter Primary.....	1
20	95-5806	Bracket, Air Cleaner Mount	1
21	322-6	Screw, Cap 5/16-18 x 1-1/4.....	3
22	3296-29	Nut, Nyloc 5/16-18	2
23	3256-3	Washer, Flat Std 5/16	4
24	95-5805	Cleaner, Remote Air W/Filter.....	1
25	1-643009	Clamp, Hose 1.31-2.25	2
26	1-643084	Hose, Air Inlet	1
27	32128-20	Nut, Whizlock 5/16-18	2
28	1-643164	Cap, Overflow Tank	1
29	1-643163	Tank, Overflow (2.0 Pts).....	1
30	1-643131	Hose, .25 ID x 22.00"	1
31	1-643259	Elbow, 90deg	1
32	1-513645	Bushing, Fuel Valve	1
33■	103-3247	Kit, Clutch Jumper Harness.....	1
34	321-2	Screw, Cap Hex 1/4-20 x 1/2.....	1
35	1-303287	Tie, Cable 5 1/2 (Small).....	3
36	1-643129	Hose, .31 ID x 27.00"	1

Item	Part No.	Description	Qty.
37	1-633851	Extension, Crankshaft.....	1
38	1-805005	Washer, Lock 5/16.....	3
39	33014-00	Nut, Hex M8.....	3
40	1-633869	Fan, Pump Cooling.....	1
41	3256-22	Washer, Flat SAE 1/4	3
42	1-809095	Screw, Hex Socket 1/4-20 x 1/2	3
43	103-0098	Shroud, Hydraulic Fan	1
44	3296-2	Nut, Nyloc #10-24	6
45	3256-14	Washer, Flat Std #10	12
46	3290-500	Screw, Mach #10-24 x 5/8	6
47	103-0895-03	Shield, Lh Liquid.....	1
48	1-633794-03	Shield, Rh Eng Shield.....	1
49	321-4	Screw, Cap HH 1/4-20x5/8	6
50	32128-33	Nut, Whizlock 1/4-20.....	6
51	33115-020	Screw, M10-1.5x20mm	2
52●	103-3244	Clutch (103-6589) Kit.....	1
	103-3012	Kit, Brake Pole Module	1
53	1-303335	Tie, Cable 7 15/16 (Large)	1
54	3256-3	Washer, 5/16 Std	1
55	1-613235	Washer.....	4
56	1-633543-03	Strap, Clutch/Brake.....	1
57	1-633545	Spacer, Grommet	2
58	1-633630	Grommet	2
59	322-19	Screw, Cap HH 5/16-18 x 4	1
60	103-0113	Clip, Loom	1
61	33115-025	Screw, M10-1.5 x 25mm	4
62	1-603610	Washer, Disc Spring 7/16	2
63▲	33115-035	Screw, Cap M10x1.5 x 35mm	1
64	94-3652	Cover W/Latch.....	1
65	1-643283	Latch, Air Cleaner	2
66	87-9400	Vacuator Valve	1
67	103-0114	Spacer, Clutch	1
68	103-0152	Keeper, Clutch.....	1
69	103-3068	Valve, Oil Drain.....	1
70	103-1564	Gasket, Exhaust	2
71	103-1511	Arrester, Spark (1.50)	1
72	103-1512	Clamp, Muffler (1.63).....	1

Exmark black touch up spray paint - gloss black.

Replacement Engine Oil Filter - **Kawasaki** Part No. 49065-2078.

▲ Use Pro-Lock, Nut Type (P/N 1-840022, .5ml tube) on clutch bolt.

● Includes clutch and jumper harness kit item #73.

■ Includes jumper harness, clip and 2 plastic ties item #53.

ENGINE DECK GROUP (cont.)

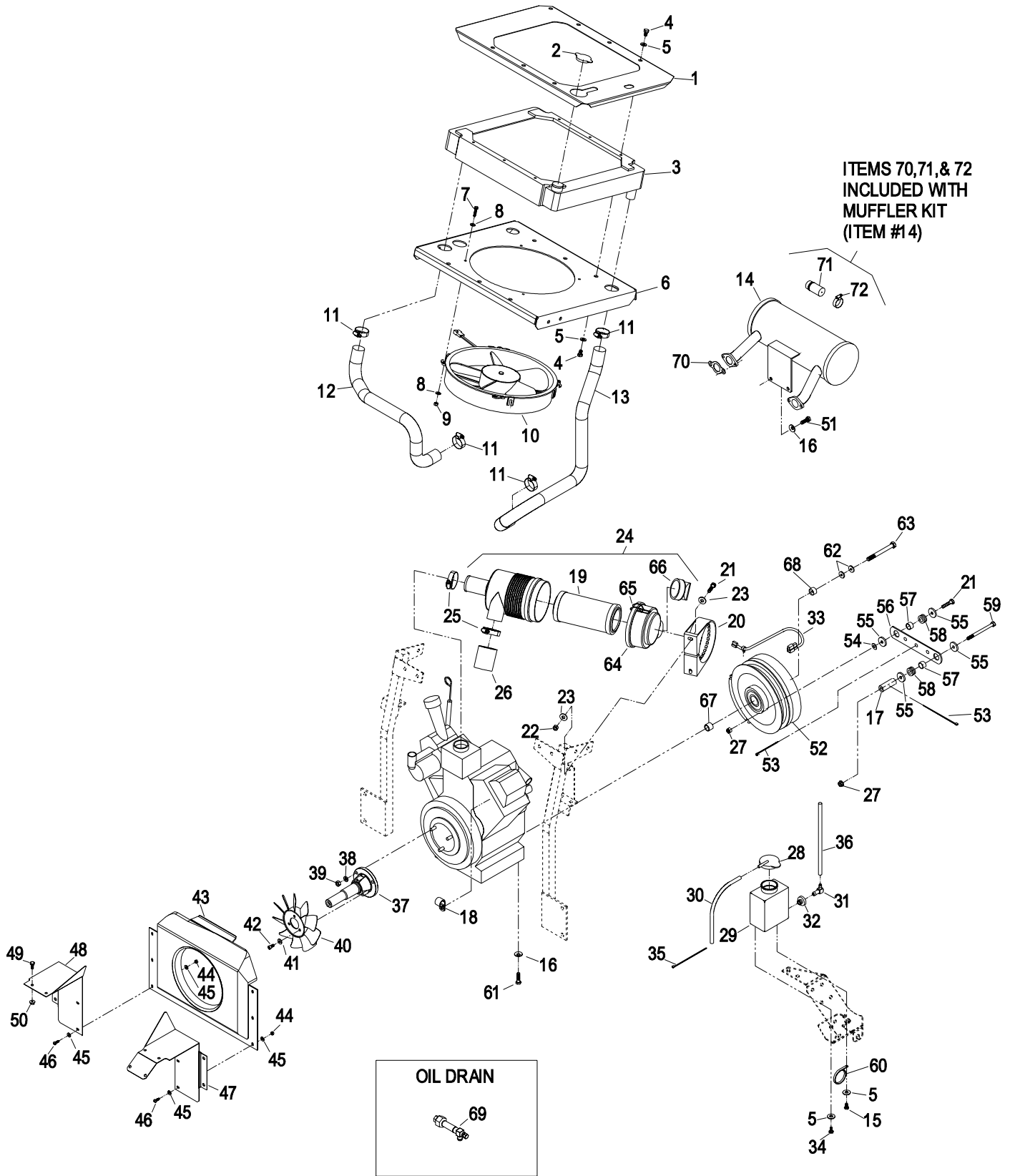

ENGINE DECK GROUP (cont.)

Item	Part No.	Description	Qty.
1	1-633864-03	Screen, Radiator Intake.....	1
2	1-803075	Screw, 10-24 X 3/4.....	4
3	3256-14	Washer, Flat Std #10	8
4	3296-2	Nut, Nyloc #10-24	4
5	322-4	Screw, Cap HH 5/16-18 x 7/8.....	8
6*	103-1044	Hood Assembly.....	1
7	3256-23	Washer, Flat Sae 5/16	20
8	3296-29	Nut, Nyloc 5/16-18	4
9	1-633885-03	Plate, Hood Hinge.....	2
10	1-632986-03	Hinge, Shackle Wld.....	2
11	32128-20	Nut, Whizlock 5/16-18	37
12	322-3	Screw, Cap 5/16-18 x 3/4.....	23
13	1-808285	Pin, Clevis 3/8 x 1 1/8	2
14	3256-24	Washer, Flat Sae 3/8	10
15	1-806003	Pin, Hair Cotter .080 #2.....	2
16	1-643106-03	Angle, Rad. Trim Side RH.....	1
17	1-643108-03	Angle, Rad. Trim Bottom.....	1
18	1-643107-03	Angle, Rad. Trim Top.....	1
19	1-643105-03	Angle, Rad. Trim Side LH.....	1
20	1-643187	Seal, Trim - 20" Length	2
21	1-643186	Seal, Trim - 14" Length	2
22	103-7452-03	Plate, Side Rad. Mnt. LH.....	1
23	1-643188	Latch, Epdm Rubber	2
24	923786	Pop Rivet.....	8
25	322-5	Screw, Cap 5/16-18 x 1.....	9
26	1-632873-03	Radiator Mount Weld-Rear.....	1
27	1-633886-03	Bumper, Rear.....	1
28	3296-42	Nut, Nyloc 1/4-20	6
29	323-6	Screw, Cap Hex 3/8-16 x 1	6
30	1-523420	Bumper, Rubber.....	2

Item	Part No.	Description	Qty.
31	3290-357	Nut, Whizlock 3/8-16.....	12
32	1-633897-03	Rib, Top.....	2
33	1-633898-03	Rib, Bottom.....	2
34	1-633877-03	Bar, Latch Hook.....	2
35	1-643189	Keeper, Rubber Latch.....	2
36	103-7623-03	Bar, Rad. Mnt. Frame	2
37	323-7	Screw, Cap HH 3/8-16 x 1-1/4	2
38	323-9	Screw, Cap HH 1/4-20 x 1 1/2	2
39	103-7453-03	Plate, Side Rad. Mnt. RH.....	1
40	103-0107-03	Brace, Radiator-LH.....	1
41	1-632985-03	Brace, Radiator-RH	1
42	1-633878-03	Crossbar.....	1
43	103-2870-03	Deflector, Air.....	1
44	3269-3	Rivet, Pop Stl 3/16 x 1/4	4
45	49-2040	Screw, Tapping 1/4-20 x 3/4	2
46	103-0110-03	Plenum, Air Intake	1
47	323-14	Screw, 3/8-16 x 3 (60")	4
	323-6	Screw, 3/8-16 x 1 (72")	4
48	103-2099-01	Weight Bar (60")	3
	100-2333-01	Weight Bar (72")	1
49	98-5975	Washer, 3/8 Disc Spring.....	4
50	1-303435	Washer, Spring Disc 1/4	5
51	103-3340	Asm, Lift Shield W/Decals.....	1
52	1-633300-03	Shield, Lift.....	1
53	1-803035	Rivet, Alum. 3/16 x 1/4.....	3
54	103-1308	Shield, Engine	1
55	32128-33	Nut, Whizlock 1/4-20.....	2
56	321-4	Screw, 1/4-20 x 3/4.....	4
57	3256-2	Washer, 1/4 Std.....	6
58	1-803072	Rivet, Bulbex .19 x 1.07.....	17

Exmark black touch up spray paint - gloss black.

* Hood assembly comes with back logo decal, side decals need to be ordered separately.

ENGINE DECK GROUP (cont.)

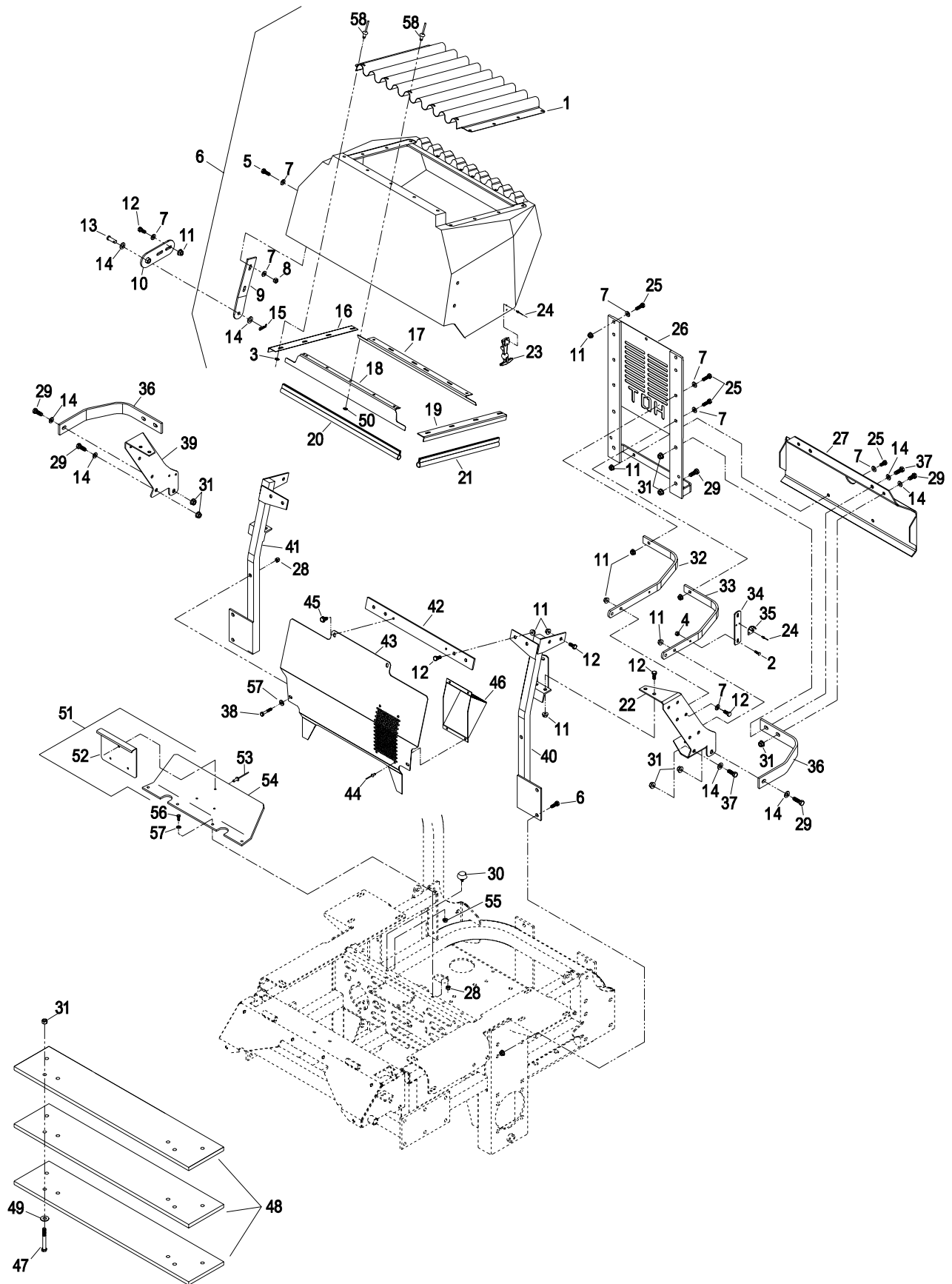

HYDRAULIC GROUP

Item	Part No.	Description	Qty.
1	103-1947	Asm, Reservoir W/Decal	1
2	103-1948	Cap, Hydraulic Reservoir	1
3	103-1949	Gasket, Reservoir Cap.....	1
4	104-7836	Head, Filter	1
5	1-513211	Element, Hydraulic Oil Filter.....	1
▲	1-523541	Element, Hydraulic Filter (Winter).....	1
6	103-1988	Clamp, Hose (11/16).....	4
7	103-1716	Clamp, Hose (17/32).....	3
8	103-1826	Asm, Hose Hydraulic.....	1
9	103-1827	Asm, Hose Hydraulic.....	1
10	103-1808	Hose, Hydraulic.....	1
11	103-1806	Asm, Case Drain Hose.....	1
12	103-1807	Elbow,45°.....	1
	1-603921	Boss O-Ring	1
13	103-1828	Adapter, Run Tee.....	1
	1-603921	Boss O-Ring	1
14	103-1801	Adapter, Straight	1
	1-603921	Boss O-Ring	1
15	103-1912	Adapter, Straight	1
	1-603921	Boss O-Ring	1
16	103-1799	Elbow,90°.....	2
	1-603921	Boss O-Ring	1
17	321-3	Screw,1/4-20 x 5/8	2
18	1-805004	Lockwasher, 1/4.....	2
19	103-1802	Elbow, 90°.....	2
	1-603921	Boss O-Ring	1
20●	103-7262	Pump, Hydraulic.....	2
■	103-8802	Pump, Hydraulic.....	2
	103-7441	Kit, Input Bearing	1
	103-8448	Kit, Thrust Bearing	1
	103-7443	Kit, Cylinder Block	1
	105-6184	Kit, Overhaul Seal	1
	103-2741	Kit, Shock Valve.....	1
21	1-603990	Connector, Straight	4
	1-603920	O-Ring (SAE #8)	1
	1-603992	O-Ring (37° Flare #8).....	1
22●	103-6988	Motor, Wheel Drive 240cc.....	2
■	103-6989	Motor, Wheel Drive 280cc.....	2
	103-6996	Kit, Output Shaft & Seals.....	1
	103-6994	Kit, Seal	1
23	103-3733	Hose, Upper LH (60").....	1
	103-3734	Hose, Upper (72")	2

Item	Part No.	Description	Qty.
24	103-3735	Hose, Lower LH (60").....	1
	103-1863	Hose, Lower (72")	2
25	103-3736	Hose, Upper RH (60").....	1
26	103-3737	Hose, Lower RH (60").....	1
27●	103-6907	Sheave, Pump	2
■	1-633568	Sheave, Pump	2
28+	1-803022	Setscrew, Sq Hd 5/16-18 x 5/8.....	2
29+	30-1710	Setscrew, Sq Hd Cup 5/16-18 x 1	2
30+	1-803050	Setscrew, Sq Hd Cup 5/16-18 x 3/4	2
31●	5-1077	Key, 3/16SQ x 1.....	2
■	1-807272	Key, 5mm x 5mm x 25mm	2
32	1-603991	Adapter, Straight (60")	4
	1-603919	Boss O-Ring	1
	1-603992	Flare O-Ring	1
	1-633786	Elbow,90° Long (72")	4
	1-603919	Boss O-Ring	1
	1-603992	Flare O-Ring	1
33	1-633167	Pulley, Idler W/Bushing.....	1
34✖	103-5694	Kit, Idler Arm (103-4595-03) W/Bearings	1
35	323-9	Screw, HH 3/8-16 x 1 3/4.....	1
36	3256-3	Washer, Flat Std 5/16	1
37	3290-357	Nut, Whizlock 3/8-16.....	8
38	103-5677	Spacer	1
39	32128-33	Nut, Whizlock 1/4-20.....	2
40	1-633567	Sheave, Engine	1
41●	103-6906	Belt, Pump Drive.....	1
■	1-633569	Belt, Pump Drive.....	1
42	323-8	Screw,3/8-16 x 1 1/2	1
43	1-800805	Screw,3/8-16 x 3 1/2 Gr8	1
44	323-7	Screw,3/8-16 x 1.....	4
45	106-7159	O-ring	2
46	13-2840	Key, 1/4 x 1/4 x 1 1/4.....	1
47	302-40	Zerk,90° 1/4-28.....	1
48	103-3504	Bearing, Spherical	2
49	103-3330	Spring, Extension.....	1
50	321-6	Screw, HH 1/4-20 x 1	2
51	3256-22	Washer, SAE 1/4	2
52	103-2916	Guard, Top	2
53	103-3506	Seal, Single Lip.....	2
54	32120-10	Ring, Retaining	2

Exmark black touch up spray paint - gloss black.

✚ Use Pro-Lock, Nut Type (P/N 1-840022, 5 ml tube) on setscrews.

▲ Use only for operation below 32°F (0°C).

● This component is required for units with S/N 510,000 thru 527,799.

■ This component is required for units with S/N 527,800 and higher.

HYDRAULIC GROUP

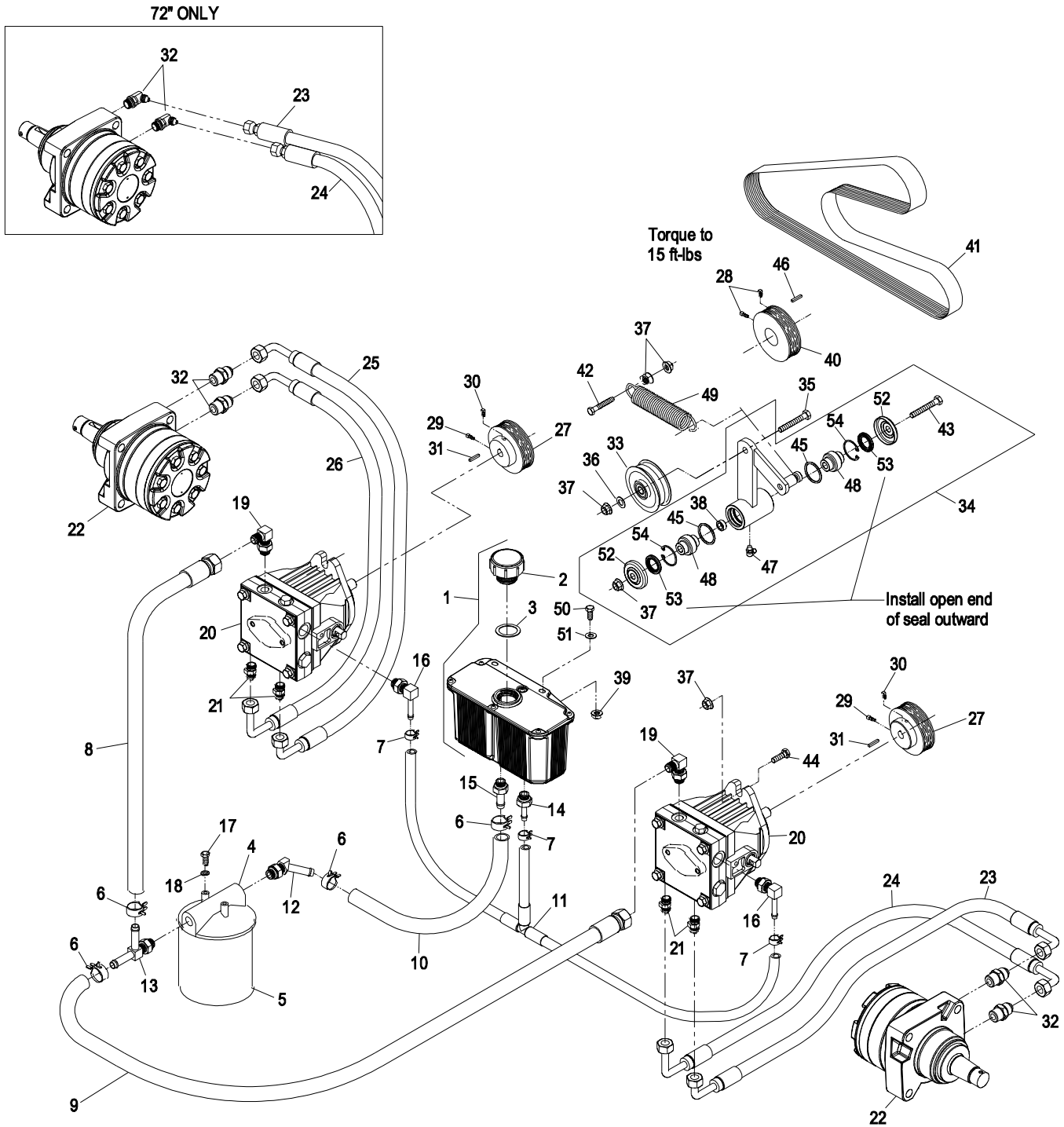

DECAL GROUP

Item	Part No.	Description	Qty.
1	103-3794	Decal, Park Brake	1
2	103-3979	Decal, Cutting Height	1
3	107-2112	Decal, Warning Slope	1
4	103-6319	Decal, Check Service.....	1
5	1-643222	Decal, Belt Routing	1
6■	1-323540	Decal, Roller Mounting.....	1
7	1-633706	Decal, Deck Height	1
8	103-1798	Decal, Throttle.....	1
9	1-643253	Decal, Radiator Fan	2
10	1-513742	Decal, No Step.....	2
11	103-0262	Decal, Fuel Valve.....	1
12	1-513748	Decal, Guard.....	1
13	103-2076	Decal, Hot Surface	2
14	103-3270	Decal, 3750 RPM.....	1
15	103-1147	Decal, Ultracut 72	1
16	1-643339	Decal, Pump Belt Rtg.....	1
17	1-303508	Decal, Discharge Warning.....	1
18	103-3112	Decal, LC Lazer Model.....	1
19	103-4474	Decal, Ignition/PTO.....	1

Item	Part No.	Description	Qty.
20	103-0223	Decal, Shell Coolant	1
21	103-4930	Decal, Choke	1
22	103-1077	Decal, Bolt Torque	1
23	103-1027	Decal, Relay	1
24	1-403005	Decal, Danger.....	2
25	98-5954	Decal, Missing Cover.....	2
26	1-633313	Decal, Warning	1
27	1-643401	Decal, Mercury Switch	1
28	1-633462	Decal, Important	1
29	107-2102	Decal, Rops Folding.....	1
30	1-633922	Decal, Anti-Scalp	1
31	1-523552	Decal, Hyd Tank/Hot Surface.....	1
32	103-5881	Decal, Rotating Devices.....	1
33	103-4574	Decal, Exmark Logo.....	1
34	103-1146	Decal, Ultracut 60	1
35	103-1141	Decal, Hood LH	1
36	103-1142	Decal, Hood RH.....	1
37	103-4973	Decal, Console Top	1
	103-5471	Decal Kit LZ LC	

■ Decal used on decks with type A anti scalp axles. Reference pages 3-6.

DECAL GROUP

1 **WARNING**
To avoid serious injury or death:
Read and understand the operator's manual before using this machine.
• DO NOT operate unless trained to safely use this machine.
• DO NOT operate under the influence of alcohol or drugs.
• DO NOT operate without guards, shields, and safety devices in place and working.
• Check the function of the operator presence control (OPC) safety system only. Do NOT disable the OPC system.
• Stop engine and remove key before adjusting, servicing or cleaning machine and attachments.
• Hearing protection is recommended.

2 **DANGER**
To avoid serious injury or death:
• Avoid slopes unless engine and blades are stopped.
WARNING
To avoid serious injury or death:
• Pick up objects that could be thrown by the blades.
• DO NOT mow when people and pets are in the area.
• DO NOT carry passengers.
• Look behind and to the side before changing directions.
• Drive leaving the operator's position:
• Disengage PTO.
• Move drive levers out to neutral lock position.
• Engage park brake.
• Stop engine.

3 **WARNING**
• Operating on wet grass or steep slopes can cause sliding and loss of control.
• Wheels dropping over edges can cause rollovers, which may result in serious injury, death or drowning.
• To avoid loss of control and possibility of rollover:
• DO NOT operate near drop-offs or near water.
• DO NOT operate on slopes greater than 15°.
• Reduce speed and use extreme caution on slopes.
• Avoid sudden turns or rapid speed changes.
• There is no roll over protection when the roll bar is down.
• Always keep roll bar in the raised and locked position and use seat belt.
• Read and follow rollover protection instructions and warnings.

4 **CHECK/SERVICE REFERENCE AID**
GREASE LUBE POINTS AT INTERVALS SHOWN.
CHECK HYDRAULIC FLUID AT INTERVAL SHOWN. (USE ONLY MOBIL 1 15W-50 SYNTHETIC MOTOR OIL.)
SEE ENGINE OPERATOR'S MANUAL FOR SERVICING ENGINE.
CHECK THE TIRE PRESSURE IN PNEUMATIC TIRES - 13 PSI AT INTERVAL SHOWN.
SEE OPERATOR'S MANUAL FOR ADDITIONAL DETAILS.

5 **BELT ROUTING**
BLADE BELT - 72"
440002-72
143007-60P
143006-02

6 **ITEM NAME**
1 ROLLER
2 SPRING WASHER
3 SPRING WASHER
4 3/8-16 X 4 BOLT
5 MOUNT BRACKET
6 FLAT WASHER
7 WELLOCK NUT
8 TORQUE BOLT
9 TORQUE BOLT
TORQUE BOLT MUST BE INSTALLED AS SHOWN IN DIAGRAM. TORQUE NUT TO 35-45 FT.-LBS.

7 1.5, 2.0, 2.5, 3.0, 3.5, 4.0, 4.5

8 Engine RPM 3750 ± 50 (no load)

9 **CAUTION**
ROTARY BLADES: STOP ENGINE BEFORE RELOCATING UNDESIRABLY.

10 **NO STEP**

11 RH, LH, OFF

12 **CAUTION**
DO NOT OPERATE WITHOUT GUARD IN PLACE.

13 **CAUTION**
HOT SURFACE

14 Engine RPM 3750 ± 50 (no load)

15 **ULTRACUT 72™**

16 **PUMP BELT ROUTING**

17 **WARNING**
DO NOT OPERATE WITHOUT DISCHARGE DEFLECTOR, ENTIRE GRASS COLLECTION SYSTEM, OR MULCH KIT IN PLACE. DO NOT REMOVE GRASS CATCHER UNTIL BLADES HAVE STOPPED.

18 **LAZER Z™ LIQUID COOLED**

19 Engine and changed at 12 strokes

20 This cooling system protected by: Shell DEX-COOL™ Extended Life Antifreeze/Coolant. *To use only with Shell DEX-COOL™ Extended Life Antifreeze/Coolant. *Suggested charge into full of system or 400% heat of service. *Do not mix with conventional coolants. *SHELL DEX-COOL™ Antifreeze/Coolant is available at your local retail store. Another Product Innovation From: eXmark.

21 1, 2, 3, 4, 5, 6, 7, 8, 9, 10, 11, 12, 13, 14, 15, 16, 17, 18, 19, 20, 21, 22, 23, 24, 25, 26, 27, 28, 29, 30, 31, 32, 33, 34, 35, 36, 37

22 **CAUTION**
Loose or Damaged Blade Bolt may allow blade to come out from under deck at HIGH SPEED.
• Replace Blade Bolt after striking a foreign object.
• Torque Blade Bolt to 115-120 FT.-LBS. (156-163N m).
SEE OPERATOR'S MANUAL.

23 **KILL START FAN RELAY RELAY RELAY**

24 **DANGER**
KEEP HANDS AND FEET AWAY

25 **DANGER**
COVER IS MISSING. DO NOT OPERATE THIS UNIT WHEN COVER IS NOT IN PLACE.

26 **WARNING**
DISengage BLADE CLUTCH, SHUT OFF ENGINE AND REMOVE KEY BEFORE MAKING ADJUSTMENTS, SERVICING OR CLEANING DECK.

27 MERCURY SWITCH PART NUMBER 143276. SEE OPERATOR'S MANUAL FOR DISPOSAL INSTRUCTIONS.

28 **IMPORTANT:**
BEFORE STARTING ENGINE, CLEAN GRASS FROM PUMP DRIVE BELT COMPARTMENT. CHECK MORE OFTEN IN DRY CONDITIONS.

29 **WARNING**
TO AVOID INJURY OR DAMAGE FROM ROLL-OVER:
• Never follow the top raised and locked position of the roll bar when driving slowly and carefully.
• Raise the roll bar as soon as driver permits.
• Read and follow slope operation instructions and warnings.

30 **ANTI-SCALP ROLLER ADJUSTMENT**
FOR NORMAL OPERATING CONDITIONS, PLACE ROLLERS IN POSITIONS SHOWN FOR 34" (19 mm) GROUND CLEARANCE.
CUTTING HEIGHT (INCHES/CM): 2.25(5.7), 2.5(6.35), 2.75(7), 3(7.62), 3.25(8.25), 3.5(8.89).
FOR MAXIMUM FLOTATION, ROLLERS MAY BE POSITIONED LOWER, BUT MUST MAINTAIN A MINIMUM OF 1" (25.4 mm) GROUND CLEARANCE. NEVER POSITION THE ROLLERS TO SUPPORT THE MOWER TRUCK.

31 **CAUTION**
HOT SURFACE

32 **WARNING**
ROTATING MECHANICAL DEVICES CAN CAUSE SERIOUS INJURY:
• DO NOT operate without guards in place.
• Stop engine before opening cover.

33 **eXmark**

34 **ULTRACUT 60™**

35 **27 HP LIQUID-COOLED**

36 **27 HP LIQUID-COOLED**

37 **CAUTION**
Battery is hazardous to persons and can cause serious fires.
• Never attempt to open or repair battery.
• Avoid contact with mercury.
• See operator's manual for disposal guide.
WARNING
Battery contains sulfuric acid. Avoid contact and always shield eyes, face, skin and clothing from battery. Cigarettes, flames or sparks could cause battery to explode. Do not charge or use booster cables for adjust most connections without proper training. In event of an accident flush with water and call a physician immediately. Keep out of reach of children.
DRIVE WHEEL RELEASE
One turn counter-clockwise to release. Do not over-tighten.

KAWASAKI ELECTRICAL GROUP

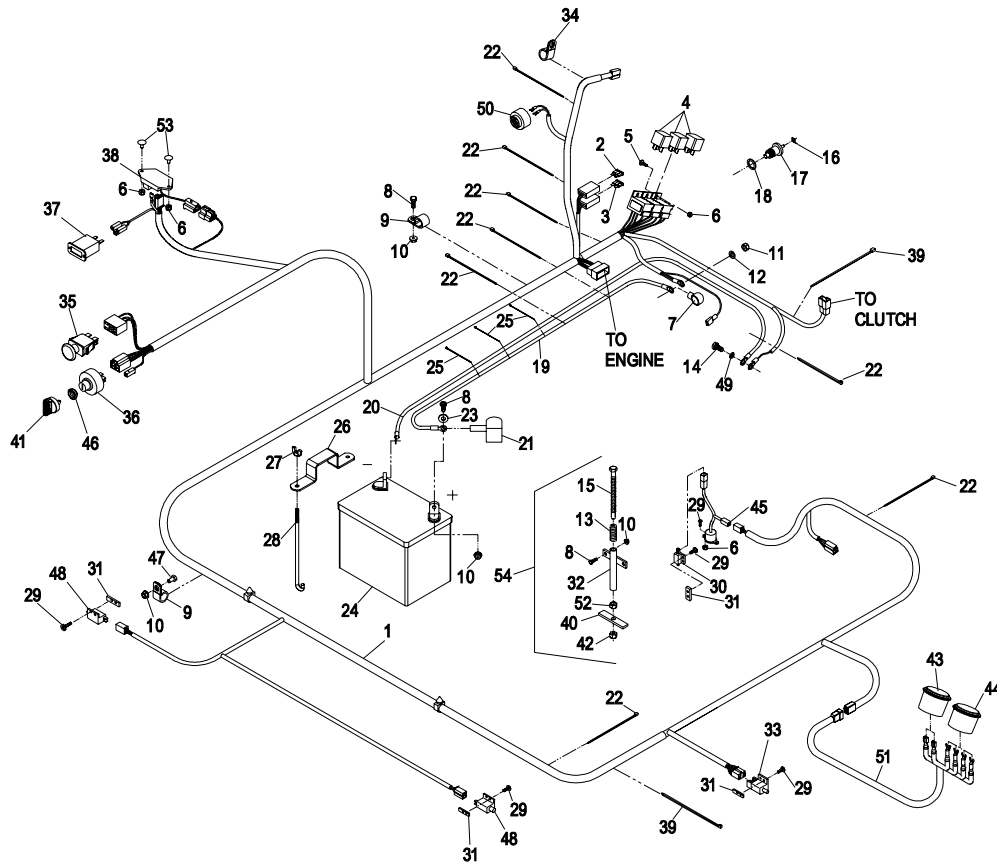

Item	Part No.	Description	Qty.
1▲	103-4734	Harness, Wiring	1
2	1-816001	Fuse-20 Amp	1
3	1-816003	Fuse-30 Amp	1
4	1-643275	Relay, 12V	3
5	1-803071	Screw, Machine #10-24 x 1/2.....	2
6	3296-2	Nut, Nyloc #10-24	6
7	1-543393	Insulator, Solenoid +	1
8	321-4	Screw, 1/4-20 x 3/4	5
9	1-633396	Clip- Loom .69.....	2
10	32128-33	Nut, 1/4-20 Whizlock.....	6
11	33014-00	Nut, Hex M8-1.25.....	1
12	3256-23	Washer, 5/16 SAE.....	1
13	1-523415	Spring, Seat Switch.....	1
14	33114-016	Screw, Hex M8-1.25 x 16mm	1
15	1-800282	Screw, 5/16-18 x 7	1
16	1-643145	Tab, #10 stud 1/4 Spade 45°.....	1
17	103-0283	Sender Unit, Temp.....	1
18	1-643153	Washer, Alum. Sender Gasket.....	1
19	1-523279	Cable, Battery (+).....	1
20	1-633307	Cable, Battery (-).....	1
21	1-543391	Insulator, Battery.....	1
22	1-303335	Tie, Plastic (Medium)	8
23	3256-2	Washer, 1/4 Flat.....	2
24	103-0293	Battery, 12V	1
25	1-303287	Tie, Plastic (Small)	3
26	1-633652-03	Hold Down, Battery	1
27	1-543792	Wingnut, Nyloc.....	2
28	1-633651	Bolt, Battery Holddown.....	2

Item	Part No.	Description	Qty.
29	3290-500	Screw, #10-24 x 5/8.....	10
30	1-513152	Switch, Seat N.C.....	1
31	1-633181	Plate, Tapped	4
32	1-522424-03	Spring Mount Wldmt	1
33	1-633111	Switch, Brake N.O./N.C.	1
34	1-603727	Clip, Loom .50	1
35	103-5221	Switch, PTO.....	1
36	103-0206	Switch, Ignition W/ Keys	1
37	1-513374	Meter, Engine Hours	1
38	103-5218	Module, Seat Delay	1
39	1-643115	Tie, Plastic (Large).....	2
40	1-513180	Actuator, Seat Switch.....	1
41	103-2106	Key, Exmark Logo	1
	1-603511	Key, Ignition.....	1
42	3296-29	Nut, 5/16-18 Nyloc.....	1
43	1-643037	Gauge, Voltmeter.....	1
44	103-2426	Gauge, Temperature.....	1
45▲	1-633782	Switch, Tilt	1
46	103-0498	Nut, Ignition	1
47	321-2	Screw, 1/4-20 x 1/2.....	1
48	1-513051	Switch, Drive Lever N.O.....	2
49	3256-23	Washer, 5/16 SAE	1
50	103-0205	Alarm, Dual Tone.....	1
51	103-5379	Harness, Gauge.....	1
52	3217-6	Nut, Hex 5/16-18.....	1
53	1-807513	Bolt, Carriage #10-24 x 1/2	2
54	103-5652	Asm, Seat Switch Actuator.....	1

▲ Use dielectric grease on all wiring harness connectors.

KAWASAKI ELECTRICAL DIAGRAM

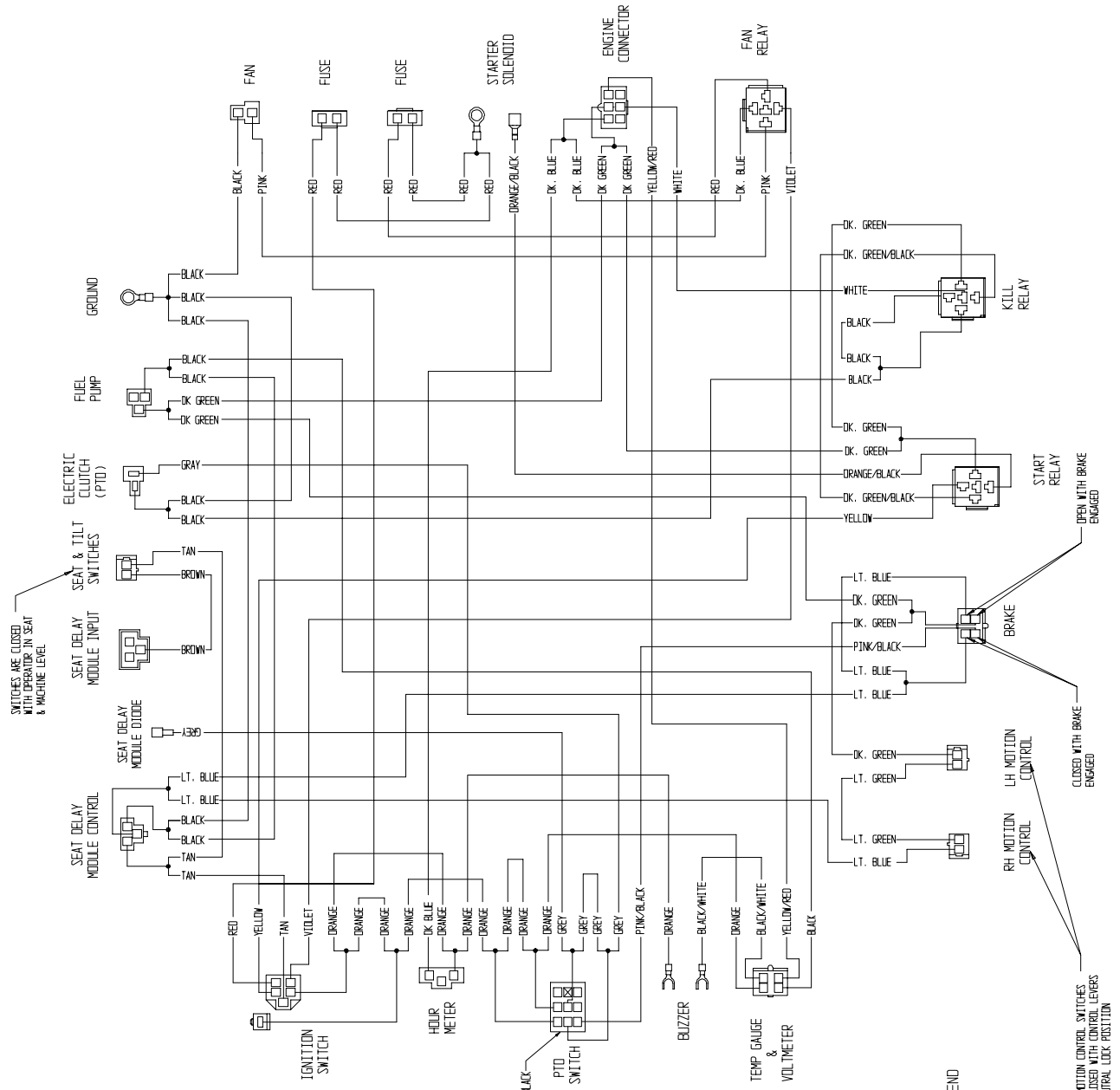

IGNITION SWITCH

TERMINAL	CONNECTIONS
TERMINAL A	FAN RELAY
TERMINAL B	BATTERY
TERMINAL I	HOUR METER, PTO SWITCH
TERMINAL S	START RELAY
TERMINAL X	SEAT DELAY, TILT SWITCH
TERMINAL Y	HOUR METER, PTO SWITCH

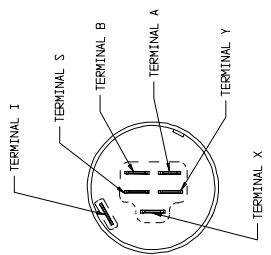

POSITION	CIRCUIT "MAKE"
1. OFF	NONE
2. RUN	B + I + A X + Y
3. START	B + I + S

NOTE: CONNECTORS VIEWED FROM WIRE END

BOTH MOTION CONTROL SWITCHES ARE CLOSED WITH CONTROL LEVERS IN NEUTRAL LOCK POSITION

KAWASAKI ELECTRICAL LOGIC SCHEMATIC

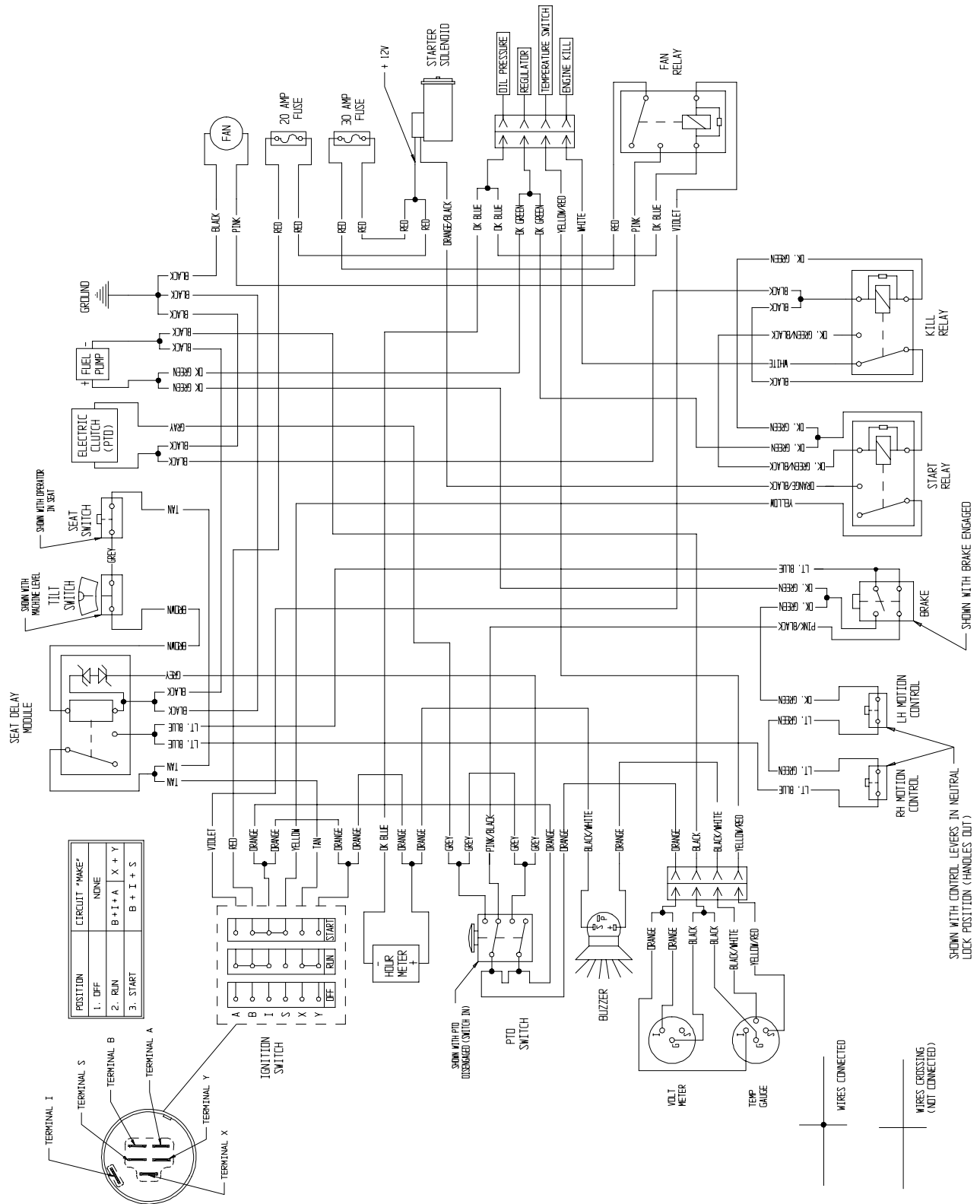

SERVICE RECORD

Date	Description of Work Done	Service Done By

SEE EXMARK'S COMPLETE LINE OF ACCESSORIES

RIDING ACCESSORIES

CUSTOM RIDE SEAT SUSPENSION SYSTEM
DECK LIFT ASSIST KIT
HITCH KIT
LIGHT KIT
MICRO-MULCH SYSTEM
ROLL OVER PROTECTION SYSTEM (ROPS)
SNOW BLADE
SUN SHADE
TRASH CONTAINER
TURF STRIPER
ULTRA VAC COLLECTION SYSTEM
ULTRA VAC QUICK DISPOSAL SYSTEM

WALK BEHIND ACCESSORIES

GRASS CATCHER
MICRO-MULCH SYSTEM
STEERABLE SULKY
SULKY HITCH KIT
TURF STRIPER

Check us out on the Web:
www.exmark.com

© 1997-2004 EXMARK MFG. CO. INC.
INDUSTRIAL PARK BOX 808
BEATRICE, NE 68310

PART NO. 103-7212 REV. A
(402) 223-6300
FAX (402) 223-5489

ALL RIGHTS RESERVED

PRINTED IN U.S.A.

