

OPERATOR'S MANUAL

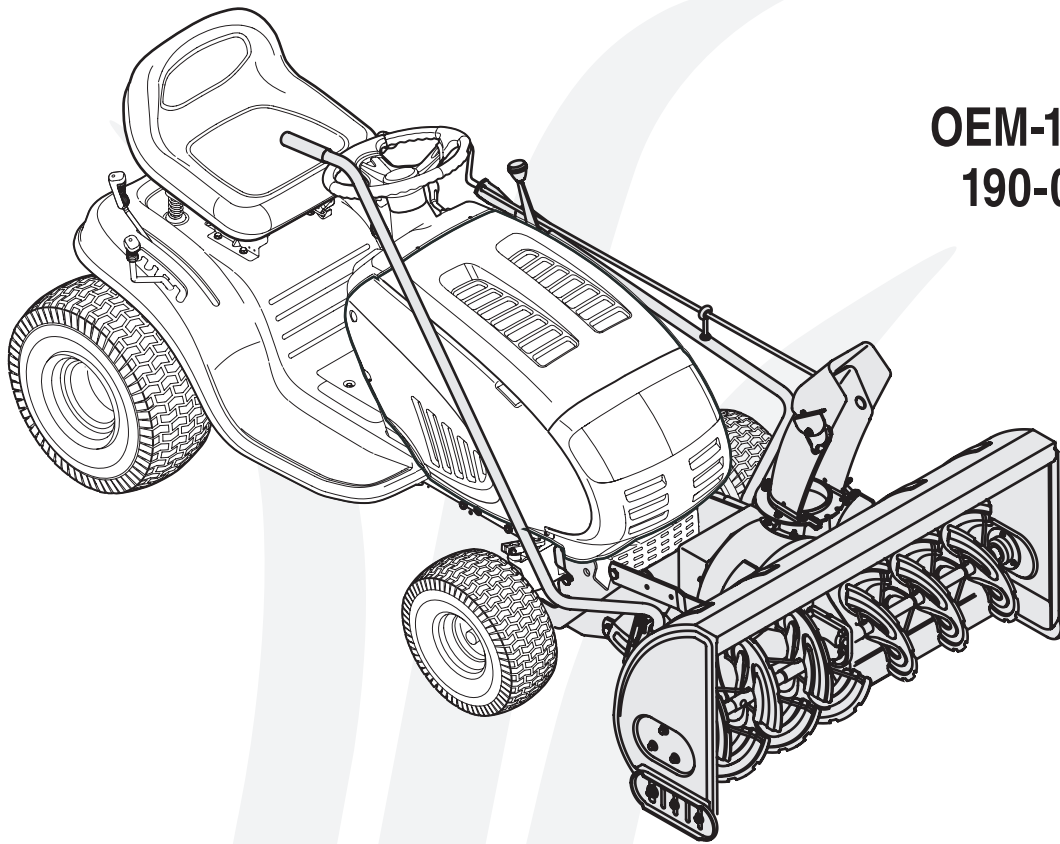

Model
OEM-190-032
190-032-101

42-inch Two-Stage Snow Thrower Attachment For FastAttach™ Compatible Lawn Tractors & Garden Tractors

IMPORTANT

READ SAFETY RULES AND INSTRUCTIONS CAREFULLY BEFORE OPERATION

Warning: This unit is equipped with an internal combustion engine and should not be used on or near any unimproved forest-covered, brush-covered or grass-covered land unless the engine's exhaust system is equipped with a spark arrester meeting applicable local or state laws (if any). If a spark arrester is used, it should be maintained in effective working order by the operator. In the State of California the above is required by law (Section 4442 of the California Public Resources Code). Other states may have similar laws. Federal laws apply on federal lands. A spark arrester for the muffler is available through your nearest engine authorized service dealer or contact the service department, P.O. Box 361131 Cleveland, Ohio 44136-0019.

This Operator's Manual is an important part of your snow thrower attachment. It will help you assemble, prepare and maintain the unit for best performance. Please read and understand what it says.

TABLE OF CONTENTS

1. Rider Model Identification	Page 3	9. Controls	Page 20
2. Snow Thrower Attachment Safety	Page 4-5	10. Operation	Page 21
3. Carton Contents	Page 6-7	11. Adjustments	Page 22
4. Assembly Models 600-649 & 800 Series	Page 8-13	12. Maintenance	Page 23
5. Assembly All Model 700 Series	Page 14-15	13. Parts List.....	Page 24-29
6. Attaching Controls	Page 16	13. Notes	Page 30-31
7. Attaching Auger Housing	Page 17	Warranty	Page 32
8. Routing Upper & Lower Drive Belts	Page 18-19		

Finding and Recording Model Number

BEFORE YOU START ASSEMBLING YOUR NEW EQUIPMENT,

please locate the model plate and copy the information from it in this Operator's Manual for future reference. The information on the model plate is very important if you need help from our Customer Support Department or your authorized dealer. You can locate it by looking on the top rear portion of the auger housing:

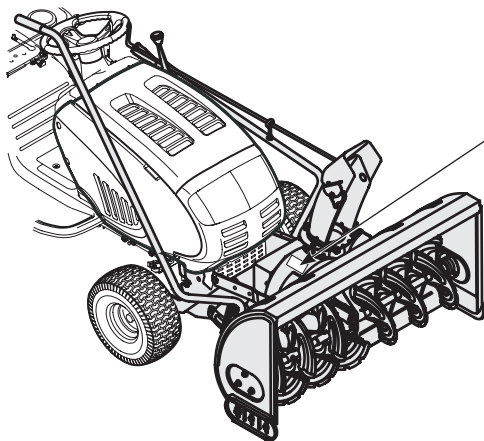

Model Number

Serial Number



MTD LLC
P.O. BOX 361131
CLEVELAND, OH 44136
330-220-4683
800-800-7310

*Locate the model plate on your snow thrower attachment and copy the information from it in the space provided above for future reference.

Customer Support

Please do *NOT* return the unit to the retailer from which it was purchased, without first contacting Customer Support.

If you have difficulty assembling this product or have any questions regarding the controls, operation, or maintenance of this unit, you can seek help from the experts. Choose from the options below:

- Visit www.mtdproducts.com. Click on the Service & Support menu option.
- Phone a **Customer Support Representative** at 1-800-800-7310.
- Please have your unit's model number and serial number ready when you call. See above to locate this information. You will be asked to enter the serial number in order to process your call.



FastAttach™ Snow Thrower Attachment

NOTE: This Operator's Manual covers several models. Snow thrower hook-up instructions vary by model. Not all features discussed in this manual are applicable to all snow thrower attachments.

To The Owner

Model OEM-190-032 42-inch two-stage snow thrower attachment is designed for use on FastAttach™ Compatible Lawn Tractors and Garden Tractors ONLY. It will NOT fit nor operate properly or safely on ANY other tractor.

Determine The Model of Your Rider

Since this manual is designed for installation of your new snow thrower attachment on several different rider units, it is important for you to determine which model of rider you have. Therefore you will know which set of instructions in the following pages to follow.

To determine which model of rider you have, you will need to locate the rider's model plate, located under the seat. Simply flip the seat up and locate the model plate, which will consist of an 11 digit/letter model number and a serial number. For ease in this installation and for future use, copy your rider's model number & serial number below now:

Rider Model Number: _____ _____

Rider Serial Number: _____

The 5th, 6th & 7th numbers from the left in your model number determine your rider's model series. See Figure 2.

When you fill in your model number in the space above, the actual model series number should fall into the gray shaded area.

Now that you have determined what model rider you are attaching this snow thrower attachment to, follow the instructions in the following pages according to your model of rider. You can locate which instructions apply to your model of rider by the gray-shaded area in the border of each page. For instance, an 809 or 80R would signify that you should follow the instructions for Model Series 800.

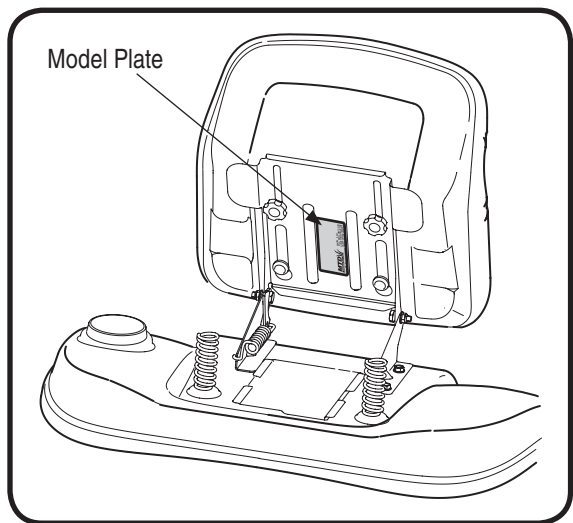

Figure 1

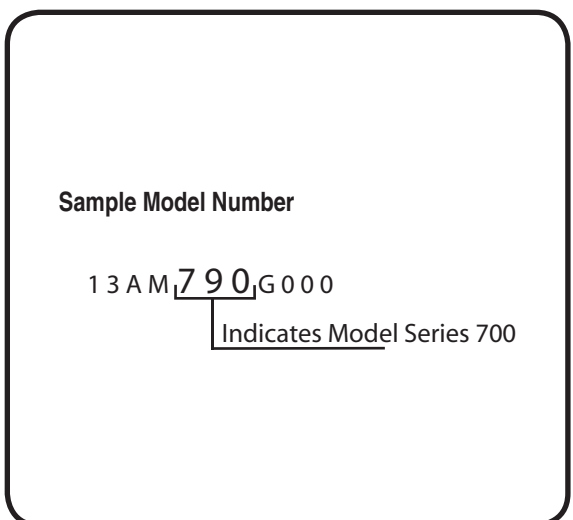

Figure 2

1

Rider Model Identification



NOTE:

References to LEFT and RIGHT indicate the left and right sides of the tractor when facing forward in the operator's position. Reference to the FRONT indicates the grille end; to the REAR, the rear end of the rider.

2

Safe Operation Practices



WARNING

This symbol points out important safety instructions which, if not followed, could endanger the personal safety and/or property of yourself and others. Read and follow all instructions in this manual before attempting to operate this machine. Failure to comply with these instructions may result in personal injury. When you see this symbol.

HEED ITS WARNING!

Your Responsibility

Restrict the use of this power machine to persons who read, understand and follow the warnings and instructions in this manual and on the machine.



WARNING: Engine Exhaust, some of its constituents, and certain vehicle components contain or emit chemicals known to State of California to cause cancer and birth defects or other reproductive harm.

DANGER: This machine was built to be operated according to the rules for safe operation in this manual. As with any type of power equipment, carelessness or error on the part of the operator can result in serious injury. This machine is capable of amputating hands and feet and throwing objects. Failure to observe the following safety instructions could result in serious injury or death.

Training

1. Read, understand, and follow all instructions on the machine and in the manual(s) before attempting to assemble and operate. Keep this manual in a safe place for future and regular reference and for ordering replacement parts.
2. Be familiar with all controls and their proper operation. Know how to stop the machine and disengage them quickly.
3. Never allow children under 14 years old to operate this machine. Children 14 years old and over should read and understand the operation instructions and safety rules in this manual and should be trained and supervised by a parent.
4. Never allow adults to operate this machine without proper instruction.
5. Thrown objects can cause serious personal injury. Plan your snow-throwing pattern to avoid discharge of material toward roads, bystanders and the like.
6. Keep bystanders, helpers, pets and children at least 75 feet from the machine while it is in operation. Stop machine if anyone enters the area.
7. Exercise caution to avoid slipping or falling, especially when operating in reverse.

Preparation

1. Thoroughly inspect the area where the equipment is to be used. Remove all doormats, newspapers, sleds, boards, wires and other foreign objects, which could be tripped over or thrown by the auger/impeller.
2. Always wear safety glasses or eye shields during operation and while performing an adjustment or repair to protect your eyes. Thrown objects which ricochet can cause serious injury to the eyes.
3. Do not operate without wearing adequate winter outer garments. Do not wear jewelry, long scarves or other loose clothing, which could become entangled in moving parts. Wear footwear which will improve footing on slippery surfaces.
4. Use a grounded three-wire extension cord and receptacle for all units with electric start engines.
5. Adjust collector housing height to clear gravel or crushed rock surfaces.
6. Disengage all control levers before starting the engine.
7. Never attempt to make any adjustments while engine is running, except where specifically recommended in the operator's manual.
8. Let engine and machine adjust to outdoor temperature before starting to clear snow.
9. To avoid personal injury or property damage use extreme care in handling gasoline. Gasoline is extremely flammable and the vapors are explosive. Serious personal injury can occur when gasoline is spilled on yourself or your clothes, which can ignite. Wash your skin and change clothes immediately.
 - a. Use only an approved gasoline container.
 - b. Extinguish all cigarettes, cigars, pipes and other sources of ignition.
 - c. Never fuel machine indoors.
 - d. Never remove gas cap or add fuel while the engine is hot or running.
 - e. Allow engine to cool at least two minutes before refueling.
 - f. Never over fill fuel tank. Fill tank to no more than ½ inch below bottom of filler neck to provide space for fuel expansion.
 - g. Replace gasoline cap and tighten securely.
 - h. If gasoline is spilled, wipe it off the engine and equipment. Move machine to another area. Wait 5 minutes before starting the engine.
 - i. Never store the machine or fuel container inside where there is an open flame, spark or pilot light (e.g. furnace, water heater, space heater, clothes dryer etc.).
 - j. Allow machine to cool at least 5 minutes before storing.

Operation

1. Do not put hands or feet near rotating parts, in the auger/impeller housing or chute assembly. Contact with the rotating parts can amputate hands and feet.
2. The auger/impeller control lever is a safety device. Never bypass its operation. Doing so makes the machine unsafe and may cause personal injury.
3. The control levers must operate easily in both directions and automatically return to the disengaged position when released.
4. Never operate with a missing or damaged chute assembly. Keep all safety devices in place and working.
5. Never run an engine indoors or in a poorly ventilated area. Engine exhaust contains carbon monoxide, an odorless and deadly gas.
6. Do not operate machine while under the influence of alcohol or drugs.
7. Muffler and engine become hot and can cause a burn. Do not touch.
8. Exercise extreme caution when operating on or crossing gravel surfaces. Stay alert for hidden hazards or traffic.
9. Exercise caution when changing direction and while operating on slopes.
10. Plan your snow-throwing pattern to avoid discharge towards windows, walls, cars etc. Thus, avoiding possible property damage or personal injury caused by a ricochet.
11. Never direct discharge at children, bystanders and pets or allow anyone in front of the machine.
12. Do not overload machine capacity by attempting to clear snow at too fast of a rate.
13. Never operate this machine without good visibility or light. Always be sure of your footing and keep a firm hold on the handles. Walk, never run.
14. Disengage power to the auger/impeller when transporting or not in use.
15. Never operate machine at high transport speeds on slippery surfaces. Look down and behind and use care when backing up.
16. If the machine should start to vibrate abnormally, stop the engine, disconnect the spark plug wire and ground it against the engine. Inspect thoroughly for damage. Repair any damage before starting and operating.
17. Disengage all control levers and stop engine before you leave the operating position (behind the handles). Wait until the auger/impeller comes to a complete stop before unclogging the chute assembly, making any adjustments, or inspections.
18. Never put your hand in the discharge or collector openings. Always use the clean-out tool provided to unclog the discharge opening. Do not unclog chute assembly while engine is running. Shut off engine and remain behind handles until all moving parts have stopped before unclogging.
19. Use only attachments and accessories approved by the manufacturer (e.g. wheel weights, tire chains, cabs etc.).
20. If situations occur which are not covered in this manual, use care and good judgment. Contact your dealer or call (800) 800-7310 for assistance and the name of your nearest servicing dealer..

Maintenance & Storage

1. Never tamper with safety devices. Check their proper operation regularly. Refer to the maintenance and adjustment sections of this manual.
2. Before cleaning, repairing, or inspecting machine disengage all control levers and stop the engine. Wait until the auger/impeller come to a complete stop. Disconnect the spark plug wire and ground against the engine to prevent unintended starting.
3. Check bolts and screws for proper tightness at frequent intervals to keep the machine in safe working condition. Also, visually inspect machine for any damage.
4. Do not change the engine governor setting or over-speed the engine. The governor controls the maximum safe operating speed of the engine.
5. Snow thrower shave plates and skid shoes are subject to wear and damage. For your safety protection, frequently check all components and replace with original equipment manufacturer's (OEM) parts only. "Use of parts which do not meet the original equipment specifications may lead to improper performance and compromise safety!"
6. Check controls periodically to verify they engage and disengage properly and adjust, if necessary. Refer to the adjustment section in this operator's manual for instructions.
7. Maintain or replace safety and instruction labels, as necessary.
8. Observe proper disposal laws and regulations for gas, oil, etc. to protect the environment.
9. Prior to storing, run machine a few minutes to clear snow from machine and prevent freeze up of auger/impeller.
10. Never store the machine or fuel container inside where there is an open flame, spark or pilot light such as a water heater, furnace, clothes dryer etc.
11. Always refer to the operator's manual for proper instructions on off-season storage.

Do not modify engine

To avoid serious injury or death, do not modify engine in any way. Tampering with the governor setting can lead to a runaway engine and cause it to operate at unsafe speeds. Never tamper with factory setting of engine governor.

Notice regarding Emissions

Engines which are certified to comply with California and federal EPA emission regulations for SORE (Small Off Road Equipment) are certified to operate on regular unleaded gasoline, and may include the following emission control systems: Engine Modification (EM) and Three Way Catalyst (TWC) if so equipped.

Your Responsibility

Restrict the use of this power machine to persons who read, understand and follow the warnings and instructions in this manual and on the machine.

2

Safe Operation Practices



WARNING

This symbol points out important safety instructions, which if not followed, could endanger the personal safety and/or property of yourself and others. Read and follow all instructions in this manual before attempting to operate this machine. Failure to comply with these instructions may result in personal injury. When you see this symbol.

HEED IT'S WARNING!

Your Responsibility

Restrict the use of this power machine to persons who read, understand and follow the warnings and instructions in this manual and on the machine.

3

Carton Contents



If you are missing any parts, please do not contact the retailer where you purchased this unit, call MTD directly at 1-330-220-4MTD or toll free at 1-800-800-7310.

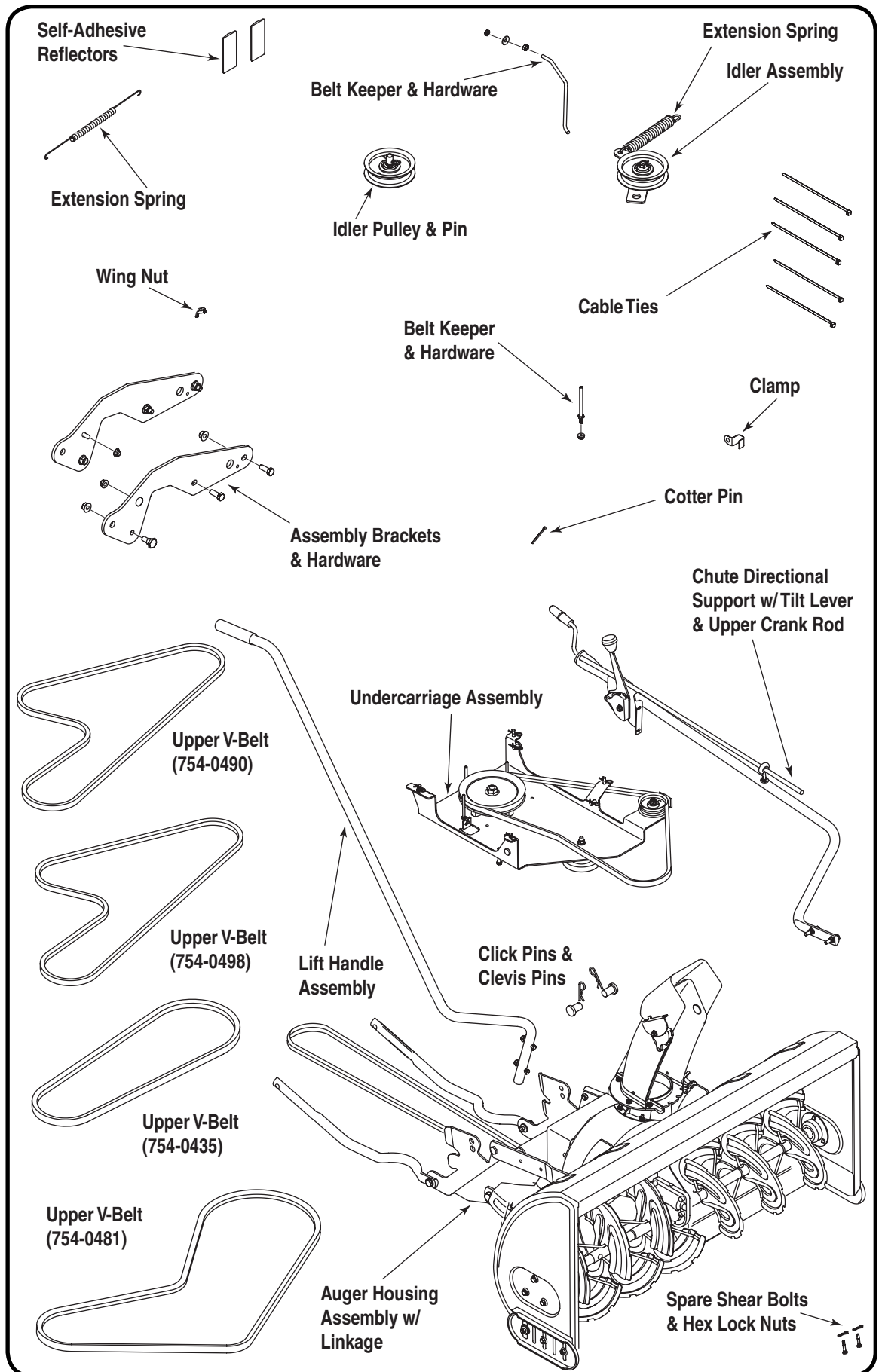

Figure 3

CONTENTS OF CARTON

Before beginning installation, remove all parts from the carton to make sure everything is present. Carton contents are listed below and shown in Figure 3. Hardware part numbers are shown in parentheses.

- One Auger Housing Assembly w/ Lower V-belt
- One Undercarriage Assembly (w/ Upper V-belt 754-0371A)
- One Idler Assembly w/ Extension Spring (732-0594A)
- One Idler Pulley (756-0627B) and Pin (650-0040) w/ Hair Pin Clip (714-0145)
- One Belt Keeper (747-04135) w/ Bell Washer (736-0270) Jam Nut (712-0298) & Hex Nut (712-3006)
- One Lift Handle Assembly
- One Upper Chute Crank Rod
- One Chute Directional Support w/ Tilt Lever
- Five Cable Ties (725-0157)
- Two Spare Shear Pins (738-04124) & Cotter Pins (714-04040)
- One Cotter Pin (714-0507)
- Two Self-adhesive Reflectors (730-3000)
- One Upper V-belt (754-0481)
- One Upper V-belt (754-0435)
- One Upper V-belt (754-0490)
- One Upper V-belt (754-0498)
- Left & Right Assembly Brackets (683-04215 & 683-04214) & Hardware (710-0514 Hex Screw, 712-04065 Flange Nut, 738-0143 Shoulder Screw & 712-04063 Flange Nut)
- Belt Keeper (711-1000) & Flange Lock Nut (712-04063)
- Wing Nut (712-04100)
- 16mm Clamp (726-0354)
- Extension Spring (732-04237)
- Clevis Pin (711-0332)
- Click Pin (714-0145)

3

Carton Contents



If you are missing any parts, please do not contact the retailer where you purchased this unit, call MTD directly at 1-330-220-4MTD or toll free at 1-800-800-7310.

4

Assembly Model Series 600-649 & All 800 series.



WARNING

Before installing attachment, place tractor on a firm and level surface. Place the PTO in the disengaged (OFF) position, set the parking brake, shut engine off and remove key to prevent unintended starting.



WARNING: Before installing attachment, place tractor on a firm and level surface. Place the PTO in the disengaged (OFF) position, set the parking brake, shut engine off and remove key to prevent unintended starting.

NOTE: References to LEFT and RIGHT indicate the left and right sides of the tractor when facing forward in the operator's position. Reference to the FRONT indicates the grille end; to the REAR the drawbar end.

IMPORTANT: You must first figure out which model of rider you are attaching this snow thrower to. Refer to Determine Your Model of Rider on page 3 of this manual to determine what model rider you are attempting to install this attachment to. Then proceed to the applicable instructions for your model of rider.

Your tractor's cutting deck, PTO belt and front deck stabilizer bracket must be removed prior to mounting the snow thrower attachment. Refer to your tractor's Operator's Manual for detailed instructions. If your tractor is equipped with any front-end accessory (i.e. front bumper kit), it must also be removed.

Mounting the Idler Pulley and Pin

(Manual PTO Tractors equipped with
a 38- or 42-inch deck ONLY)

Frame Mount Dual Idler Style 2004 & Prior

NOTE: If you engage your tractor's cutting deck by using your left hand to pivot a lever forward, your tractor has a Manual PTO. If you engage your tractor's cutting deck by pulling outward on a small knob located on the tractor's dash, your tractor has an Electric PTO.

The idler pulley and pin (packaged separately, refer to pages 6-7) must be installed to the PTO engagement plate of all manual PTO tractors with a dual-belt drive 38- or 42-inch cutting deck. If applicable, proceed as follows. Otherwise, proceed to **Mounting the Undercarriage Assembly**.

Locate the PTO engagement plate beneath your tractor. See Figure 4.

Note the location of the weld pin on the rear portion of the PTO engagement plate. This pin is where the deck brake cable attaches, when operating the tractor with the cutting deck mounted.

Remove the hair pin clip from the idler pulley and pin (packaged separately). Refer to pages 6-7.

Position the idler pulley and pin onto the weld pin of the PTO engagement plate and secure with the hairpin clip just removed.

NOTE: This Idler pulley must be removed when remounting the tractor's cutting deck.

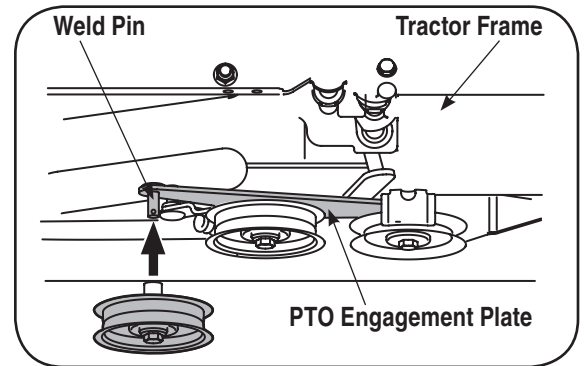

Figure 4

4

Assembly Model Series 600-649 & All 800 series.



WARNING

Before installing attachment, place tractor on a firm and level surface. Place the PTO in the disengaged (OFF) position, set the parking brake, shut engine off and remove key to prevent unintended starting.

Reversing the Idler Assembly Hardware (Manual PTO Garden Tractors equipped with a 46-inch deck ONLY)

If you're mounting this snow thrower attachment to a tractor equipped with any deck other than a manually engaged 46-inch, proceed to either:

1. **Mounting the Idler Assembly** (for tractors equipped with a 42, 46, 50 & 54-inch deck ONLY) in this section
2. **Mounting the Idler Pulley and Pin** (for Manual PTO tractors equipped with a 38- or 42-inch deck ONLY) previously in this section, or
3. **Mounting the Undercarriage Assembly** (all tractors not mentioned above) on page 12.

These instructions are for mounting this snow thrower attachment to a **GARDEN TRACTOR (Model Series 800)** equipped with a Manual PTO and a 46-inch deck.

NOTE: If you own a Manual PTO **Lawn Tractor** with a 46-inch deck, you can disregard the following steps; they are unnecessary. A **LAWN TRACTOR** is any 600-649 Series mower, an 800 Series mower is a **GARDEN TRACTOR**. Refer to **Determine Your Model of Rider** on page 3 of this manual to determine what model rider you are attempting to install this attachment to.

1. Remove the flange nut, washer and shoulder spacer which secures the double-idler bracket to the undercarriage. See Figure 5.
2. Remove the 3-inch hex bolt from the bottom of the front pulley, to free it from the undercarriage.
3. Reassemble with the 3-inch hex bolt on top of the undercarriage and the flange nut securing the pulley from the bottom. See Figure 6.

IMPORTANT: Components must be reassembled in the exact order illustrated in Figure 6.

Mounting the Belt Keeper (Manual PTO Garden Tractors equipped with a 46-inch deck ONLY)

The belt keeper and hardware (packaged separately, refer to page 6-7) must be installed around the engine pulley of all Manual PTO Garden Tractors with a 46-inch cutting deck. To do so, proceed as follows:

1. Locate the engine pulley by looking beneath the front area of your tractor.
2. Secure the belt keeper to the inside of the tractor's frame with the hex nut, bell washer and jam nut as shown in Figure 7.
3. Make certain the cupped portion of the bell washer is facing **IN** before tightening the jam nut.

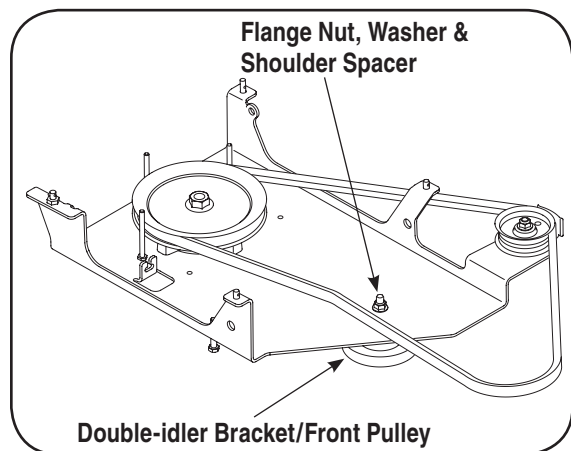

Figure 5

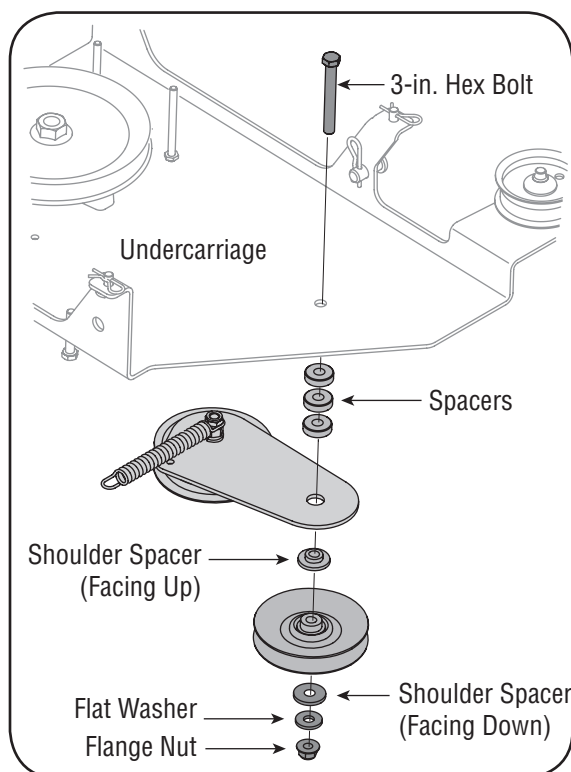

Figure 6

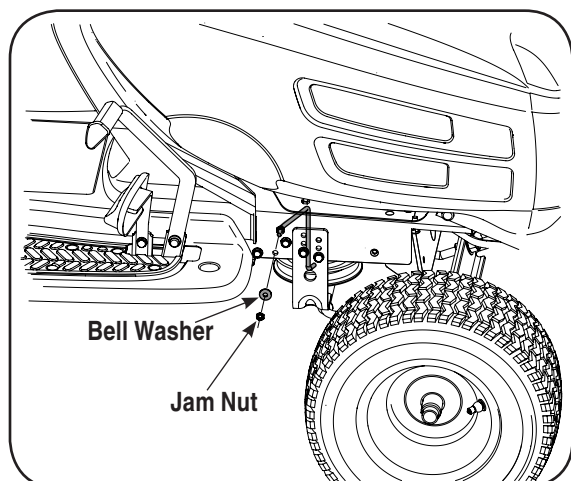

Figure 7

4

Assembly Model Series 600-649 & All 800 series

Cub Cadet
11C & 13C



WARNING

Before installing attachment, place tractor on a firm and level surface. Place the PTO in the disengaged (OFF) position, set the parking brake, shut engine off and remove key to prevent unintended starting.

Mounting the Idler Assembly (42, 46, 50, 54 inch Decks with Electric PTO)

If you're mounting this snow thrower attachment to a tractor equipped *with any deck other* than a 42, 46, 50 or 54-inch deck with electric PTO, proceed to **Mounting the Undercarriage Assembly (all tractors)**.

However, if you're mounting this snow thrower attachment to a tractor equipped with a 42, 46, 50 or 54-inch deck with electric PTO, proceed as follows:

NOTE: If you engage your tractor's cutting deck by using your left hand to pivot a lever forward, your tractor has a Manual PTO. If you engage your tractor's cutting deck by pulling outward on a small knob located on the tractor's dash, your tractor has an Electric PTO.

1. Remove the v-belt (754-0371A), this belt will be replaced later with another v-belt (754-0498) included in this carton.
2. Remove the flange nut and washer noted in Figure 8, which secures the double-idler bracket to the undercarriage. Leave the Shoulder Spacer in place.
3. Attach the idler assembly (packaged separately) over the hex screw and shoulder spacer on the surface of the undercarriage. See Figure 8.
4. Fasten the idler bracket to the undercarriage with the hardware just removed. See Figure 8.
5. Attach one end of the extension spring (732-0594A) to the hole in the idler assembly just mounted and the opposite end of the extension spring to the keeper pin as illustrated in Figure 8.
6. Position the upper v-belt (754-0498) as illustrated in Figure 9.

NOTE: For a complete detailed diagram of how to route the upper v-belt, see Routing The Upper Drive Belt beginning at the top of page 18.

NOTE: Proceed to the top of page 12 for continued

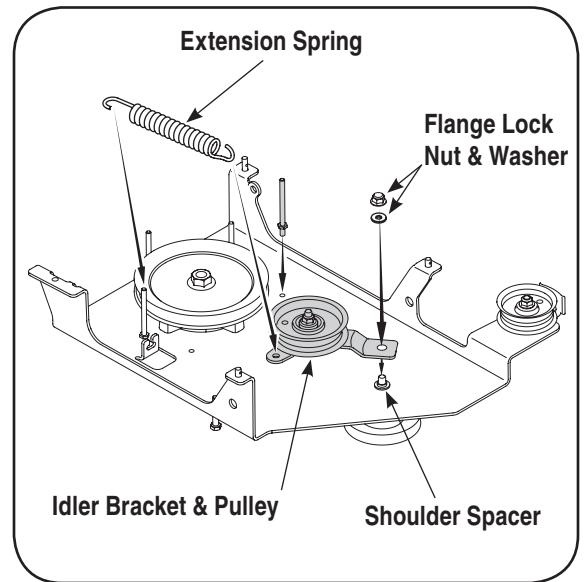

Figure 8

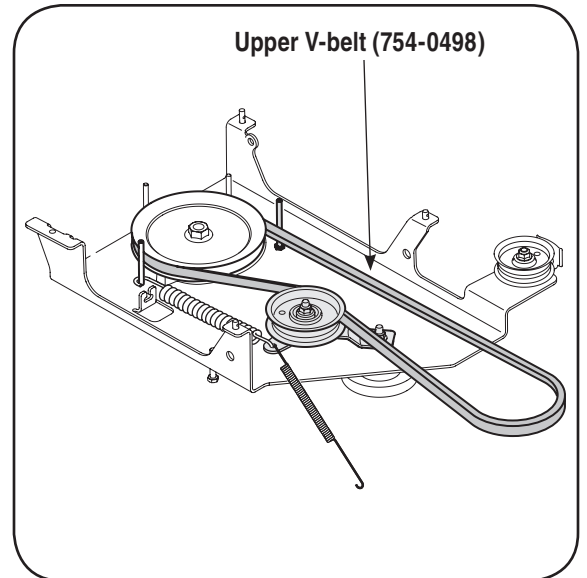

Figure 9

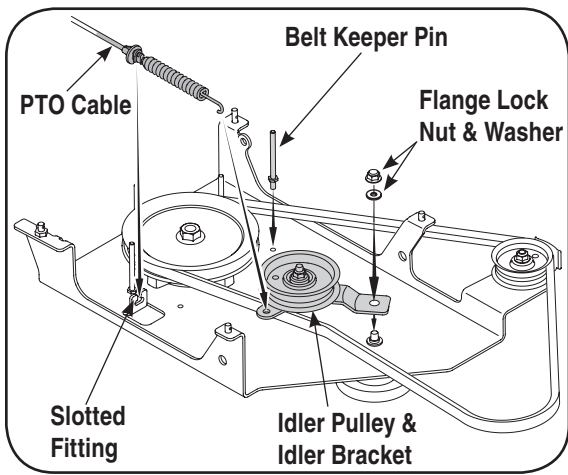

Figure 10a

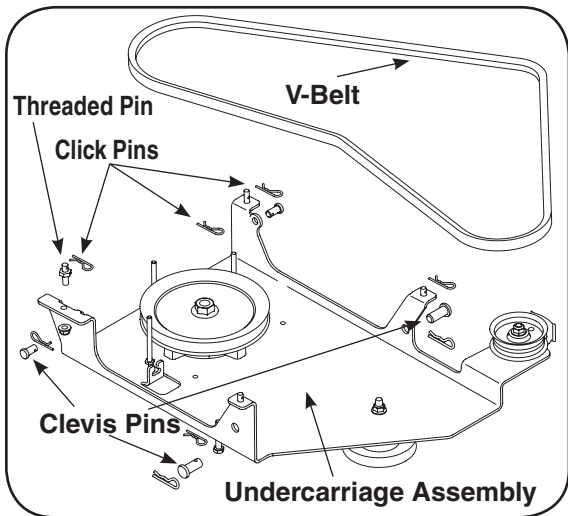

Figure 10b

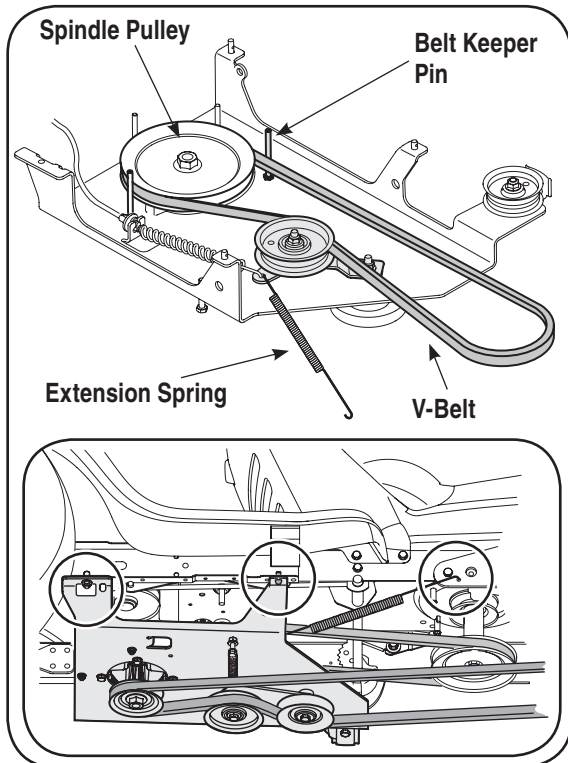

Figure 11

Undercarriage Assembly

1. Remove the v-belt (754-0371A), this belt will be replaced later with another v-belt (754-0498) included in this carton. Also, remove all of the Clevis Pins and Click pins as seen in Figure 10b.
2. Remove the flange lock nut and washer as pointed out in Figure 10a, leaving the spacer underneath it in place. Mount the idler pulley (756-0627D) and idler bracket (783-1291) from the loose parts included in this carton. Replace the flange lock nut and washer.
3. Locate v-belt part No. 754-0498 and the extension spring (Part No. 732-04237, which is .50" wide x 12" long) packaged with the loose parts in this carton. See Figure 11 for reference.

NOTE: The V-belt can be identified by the part number embossed on the outside of the belt.

Route the belt around the spindle pulley, inside of the belt keepers and to the inside of the idler pulley. The spring will connect to the Idler bracket but you may install this once the undercarriage is mounted. Otherwise it could fall off or get in the way in the following steps. If you wish to connect this later, retain the spring for later installation. See the Figure 11.

4. Attach the PTO cable to the idler bracket, then fit the cable into the slotted fitting as seen in Figure 10a.

NOTE: The PTO cable should be hanging down under you tractor after you removed the mowing deck. You will need to slide the undercarriage unit under your tractor in position for which it will be mounted. The slanted side should be pointed towards the front of your tractor.

installation instructions for the 600, 800, 11C & 13C model series.

Mounting Undercarriage Assembly

Make certain the correct upper drive belt (754-0498) is installed on the undercarriage assembly. If the appropriate belt is not installed, replace it with the correct belt prior to proceeding with mounting the undercarriage.

IMPORTANT: Make certain that the flat side of the belt is facing outward as it sits against both the idler pulley and spindle pulley. This allows the "V" side of the belt to ride snugly in both pulleys.

1. The undercarriage assembly should be in position beneath the tractor, since you already connected the PTO cable in the previous steps.

2. There should already be a threaded pin installed in one of the mounting holes of the undercarriage assembly. If not installed, install it now as in Figure 10b.

Lift the undercarriage assembly up, inserting the weld pins on the assembly up through the aligning holes found along the tractor's frame rails. Fasten with hairpin clips and flat washers removed earlier. See inset image in Figure 11.

3. Connect the extension spring found in your units loose parts that was mentioned earlier. This spring connects to the idler bracket on the undercarriage assemble and the hole on the rear right-hand snow thrower mounting bracket. See Figure 11.

4. Attach the lower auger drive belt by routing it around

4

Assembly
Model Series
600-649 &
Cub Cadet 11C
(38 & 42-inch
Decks with
Cable-Drive PTO)

*Deck Idler/
 Pull Style
 2005 & Later*



WARNING

Before installing attachment, place tractor on a firm and level surface. Place the PTO in the disengaged (OFF) position, set the parking brake, shut engine off and remove key to prevent unintended starting.

NOTE:
 Proper belt routing diagrams can be found on page 18-19 of this manual.

4

Assembly Model Series 600-649 & All 800 series

Cub Cadet
11C & 13C



WARNING

Before installing attachment, place tractor on a firm and level surface. Place the PTO in the disengaged (OFF) position, set the parking brake, shut engine off and remove key to prevent unintended starting.

and through the pulley system as seen in Figure 11.

NOTE: Proceed to page 16 for next installation steps.

Because this snow thrower attachment is compatible with several model lawn tractors and garden tractors with either an electric PTO or a manual PTO, four upper drive belts are included. If you have had any problems locating the proper upper belts for installation in the previous steps, use the table below for quick reference.

Refer to the table below to determine which upper drive belt is applicable to your tractor; non-applicable belts can be discarded. The v-belt can be identified by the part number embossed on the outside of the belt.

Upper Drive Belt Reference Chart

Deck Size	Electric PTO	Manual PTO
54-in. Deck	754-0498	N/A
50-in. Deck	754-0498	754-0481
46-in. Deck (Garden Tractor)	754-0498	754-0490
46-in. Deck (Lawn Tractor)	754-0498	754-0481
42-in. Deck (single-belt drive)	754-0498	754-0481
42-in. Deck (dual-belt drive)	754-0498	754-0498
38-in Deck (dual-belt drive)	N/A	754-0498

NOTE: If you engage your tractor's cutting deck by using your left hand to pivot a lever forward, your tractor has a Manual PTO. If you engage your tractor's cutting deck by pulling outward on a small knob located on the tractor's dash, your tractor has an Electric PTO.

Mounting The Undercarriage Assembly (All 600-649 & 800 Model Series Tractors)

1. Remove and retain the four hairpin clips from the weld pins found the top side of the undercarriage assembly, and also the 4 clevis pins with hairpin clips. Retain this hardware for later installation. See Figure 12.

IMPORTANT: Make certain the correct upper drive belt is installed on the undercarriage assembly prior to proceeding with mounting the undercarriage. Make sure that the upper v-belt is routed to the INSIDE of the belt keeper found on the undercarriage idler pulley and the keeper pins found around the spindle pulley. Also, make certain that the flat side of the belt is facing outward.

2. Position the undercarriage assembly beneath the tractor. For manual PTO units, hook up the PTO cable as described earlier in this section.
3. Move the tractor's deck lift lever into the lowest notch

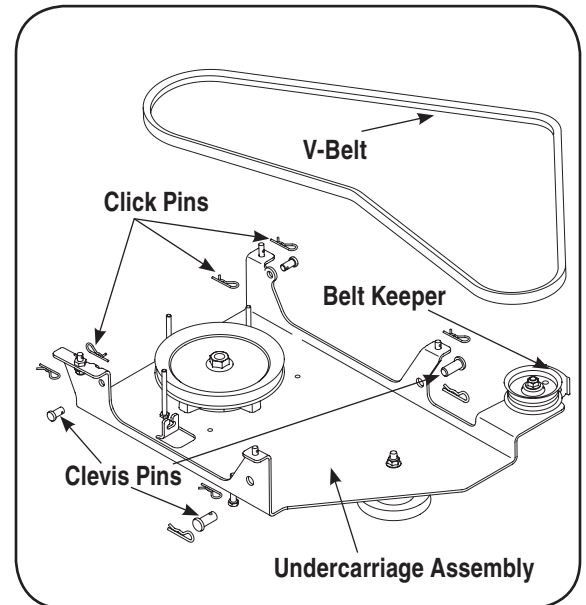

Figure 12

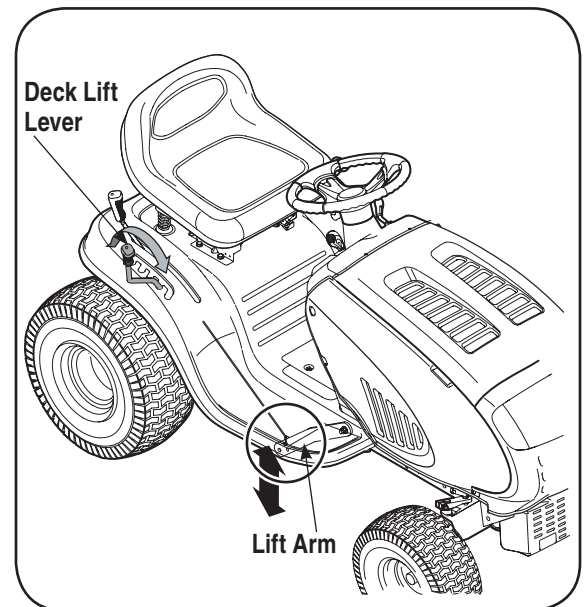

Figure 13

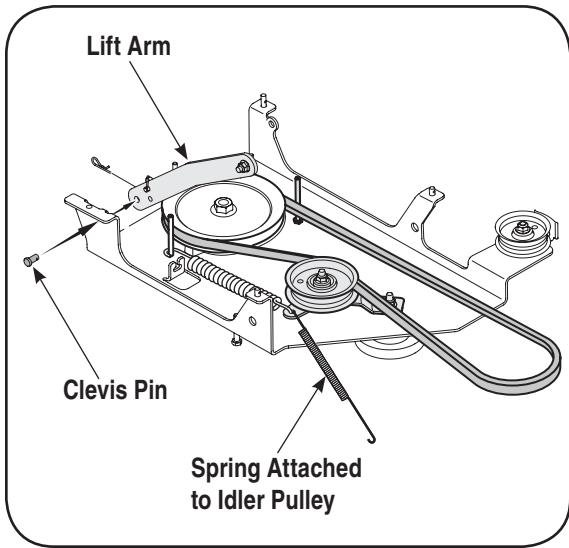

Figure 14

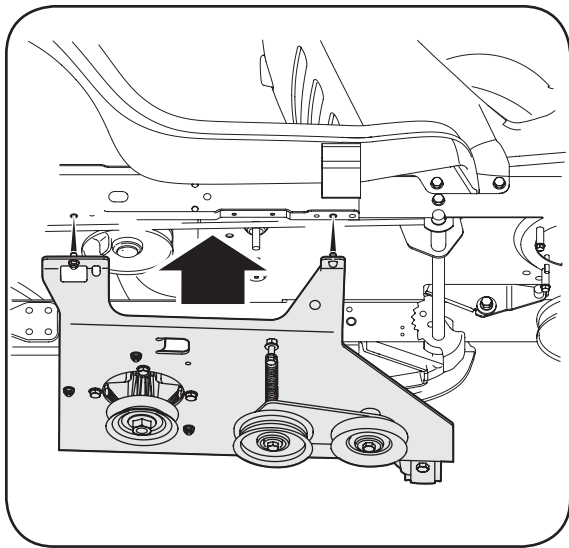

Figure 15

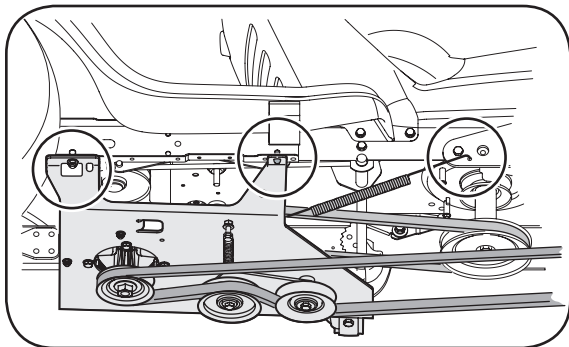

Figure 16

on the fender allowing the lift arms to drop. See Figure 13.

4. Align the holes in the rear of the lift arms with the holes in the rear of the undercarriage and insert the clevis pins removed in step 1. Fasten with the hairpin clips. See Figure 14.
5. Move the tractor's deck lift lever into the top notch on the right fender allowing the lift arms and the rear of the undercarriage assembly to rise.
6. Insert the weldpins found on the top side of the rear portion of the undercarriage assembly up through the aligning holes found along the tractor's frame rail. See Figure 15.
7. Fasten with the hairpin clips removed in step 1.
8. Repeat the previous two steps on the front portion of the undercarriage assembly.
9. Connect the extension spring to the tractor's frame rail in the hole provided. See Figure 16.

NOTE: The other end of the spring is attached to the idler pulley. For an example of where this spring should attach, see Figure 14.

NOTE: Refer to the **Routing the Upper Drive Belt** section of this manual (Page 18) for proper upper drive belt installation instructions. Routing The Lower Drive Belt instructions can also be found in that section.

4

Assembly Model Series 600-649 & All 800 series

Cub Cadet 11C & 13C



WARNING

Before installing attachment, place tractor on a firm and level surface. Place the PTO in the disengaged (OFF) position, set the parking brake, shut engine off and remove key to prevent unintended starting.

5

Bracket & Undercarriage Assembly Model Series 700-799



WARNING

Before installing attachment, place tractor on a firm and level surface. Place the PTO in the disengaged (OFF) position, set the parking brake, shut engine off and remove key to prevent unintended starting.

Bracket Assembly



WARNING: Before installing attachment, place tractor on a firm and level surface. Place the PTO in the disengaged (OFF) position, set the parking brake, shut engine off and remove key to prevent unintended starting.

NOTE: Your tractor's cutting deck, PTO belt and front deck stabilizer bracket must be removed prior to mounting the snow thrower attachment. Refer to your tractor's Operator's Manual for detailed instructions. If your tractor is equipped with any front-end accessory (i.e. front bumper kit), it must also be removed.

1. Install a shoulder screw (738-0143) and flange lock nut (712-04065) in the top front hole of each snow thrower assembly bracket as in Figure 17.
2. Mount snow thrower assembly brackets (683-04214 & 683-04215) to your tractor using the loose hardware included (Hex Screw 710-0514 & Flange Lock Nut 712-04065). See Figure 17.

NOTE: Remove the wiring harness from tractor frame (left side only) and mount on the outside of the assembly bracket using the clamp (726-0354) included with your hardware pack.

Undercarriage Assembly

1. Remove the threaded pin, click pins and clevis pins from your undercarriage assembly and retain for installation later. Also, remove the v-belt (754-0371A), this belt will be replaced later with another v-belt (754-0498) included in this carton. See Figure 18.
2. Remove the flange lock nut and flat washer as pointed out in Figure 19, leaving the spacer underneath it in place. Mount the idler pulley (756-0627D) and idler bracket (783-1291) from the loose parts included in this carton. Replace the nut and washer.
3. Attach the PTO cable to the idler bracket, then fit the cable into the slotted fitting as seen in Figure 19.

NOTE: The PTO cable should be hanging down under you tractor after you removed the mowing deck. You will need to slide the undercarriage unit under your tractor in position for which it will be mounted. The slanted side should be pointed towards the front of your tractor.

4. Locate v-belt part No. 754-0498 and the extension spring (Part No. 732-04237, which is .50" wide x 12" long) packaged with the loose parts in this carton.

NOTE: The V-belt can be identified by the part number embossed on the outside of the belt.

5. Route the belt around the spindle pulley, inside of the belt keepers and to the inside of the idler pulley. The spring will connect to the Idler bracket but you may install this once the undercarriage is mounted. Otherwise it could fall off or get in the way in the following steps. If you wish to connect this later, retain the spring for later installation. See the Figure 20 illustration on the following page.

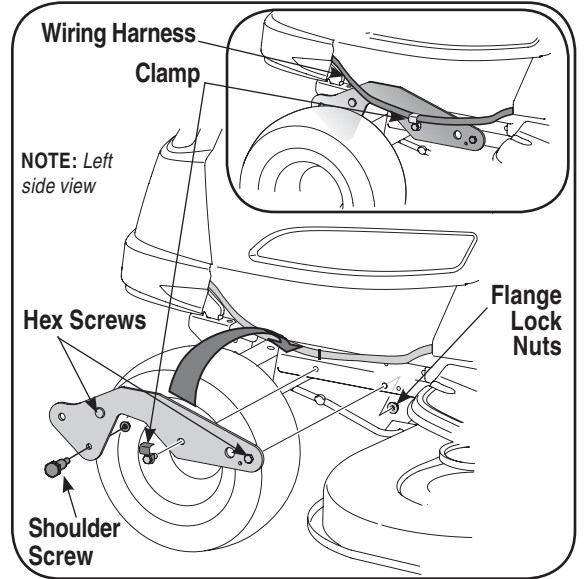

Figure 17

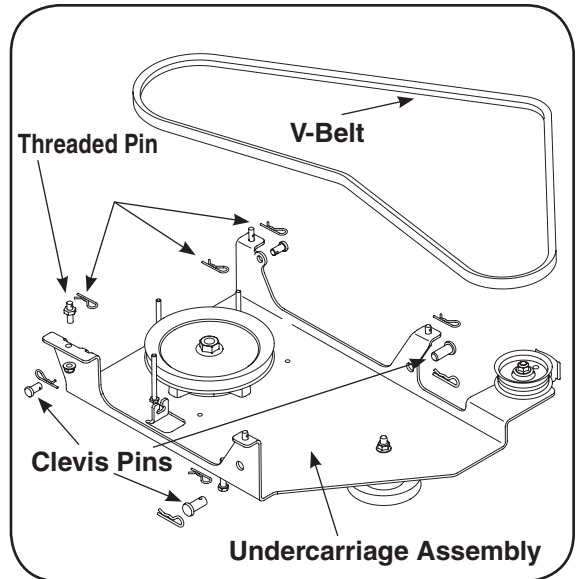

Figure 18

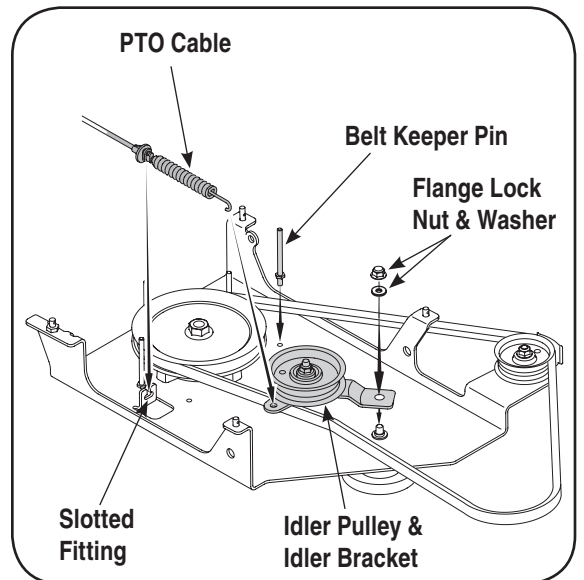

Figure 19

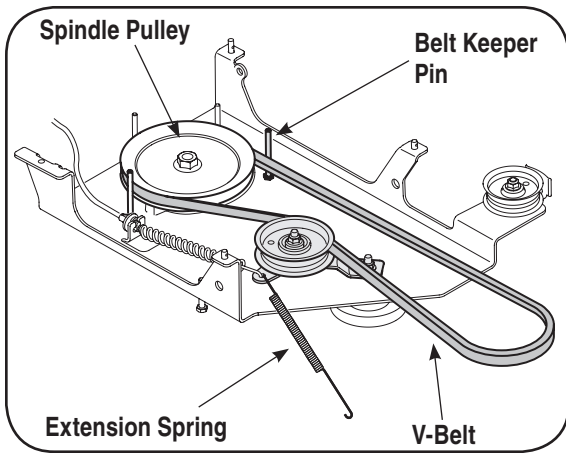

Figure 20

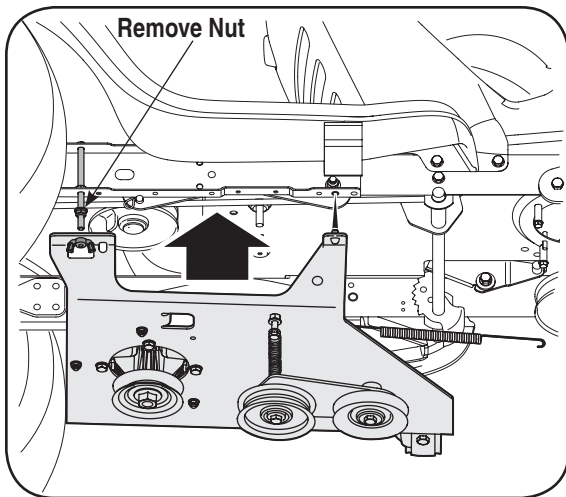

Figure 21

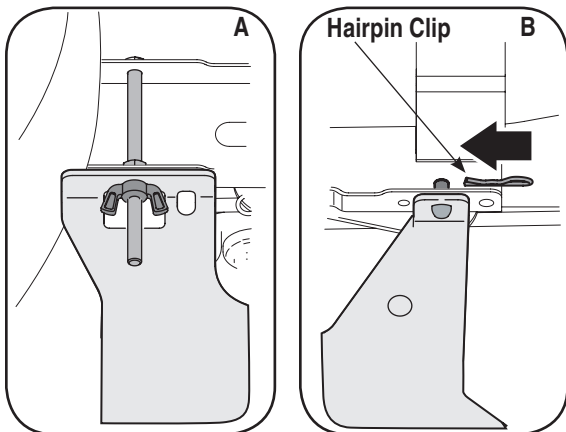

Figure 22

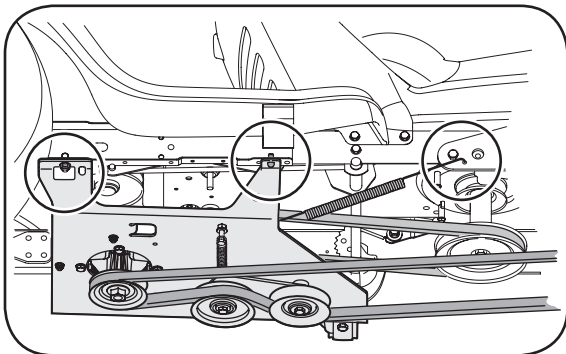

Figure 23

6. Install the additional belt keeper pin and hardware included with the loose parts in this carton. See Figure 19 for belt keeper location placement.

Mounting the Undercarriage Assembly

Make certain the correct upper drive belt (754-0498) is installed on the undercarriage assembly. If the appropriate belt is not installed, replace it with the correct belt prior to proceeding with mounting the undercarriage.

IMPORTANT: Make certain that the flat side of the belt is facing outward as it sits against both the idler pulley and spindle pulley. This allows the "V" side of the belt to ride snugly in both pulleys.

1. The undercarriage assembly should be in position beneath the tractor, since you already connected the PTO cable in the previous steps.
2. Remove the nut from the rear undercarriage mounting stud located on the tractor's frame rail on the right side of the tractor. See Figure 21.
3. Lift the undercarriage assembly up, inserting the weld pins on the assembly up through the aligning holes found along the tractor's frame rails. Fasten with hairpin clips and flat washers removed earlier. See B in Figure 22.

The rear hole on the right side will fit over the stud already installed on your tractor. Fasten with the wing nut (included with your hardware pack) and flat washer removed earlier. See A in Figure 22.

4. Connect the extension spring found in your units loose parts that was mentioned earlier. This spring connects to the idler bracket on the undercarriage assemble and the hole on the rear right-hand snow thrower mounting bracket. See Figure 23.
5. Attach the lower auger drive belt by routing it around and through the pulley system as seen in Figure 23.

NOTE: Proper belt routing diagrams can be found on page 18-19 of this manual.

5

Bracket & Undercarriage Assembly Model Series 700-799



WARNING

Before installing attachment, place tractor on a firm and level surface. Place the PTO in the disengaged (OFF) position, set the parking brake, shut engine off and remove key to prevent unintended starting.

IMPORTANT: Make certain that the flat side of the belt is facing outward as it sits against both the idler pulley and spindle pulley. This allows the "V" side of the belt to ride snugly in both pulleys.

6

Assembling Controls All Models



NOTE:

All references to left or right side of the snow thrower is from the operating position only.

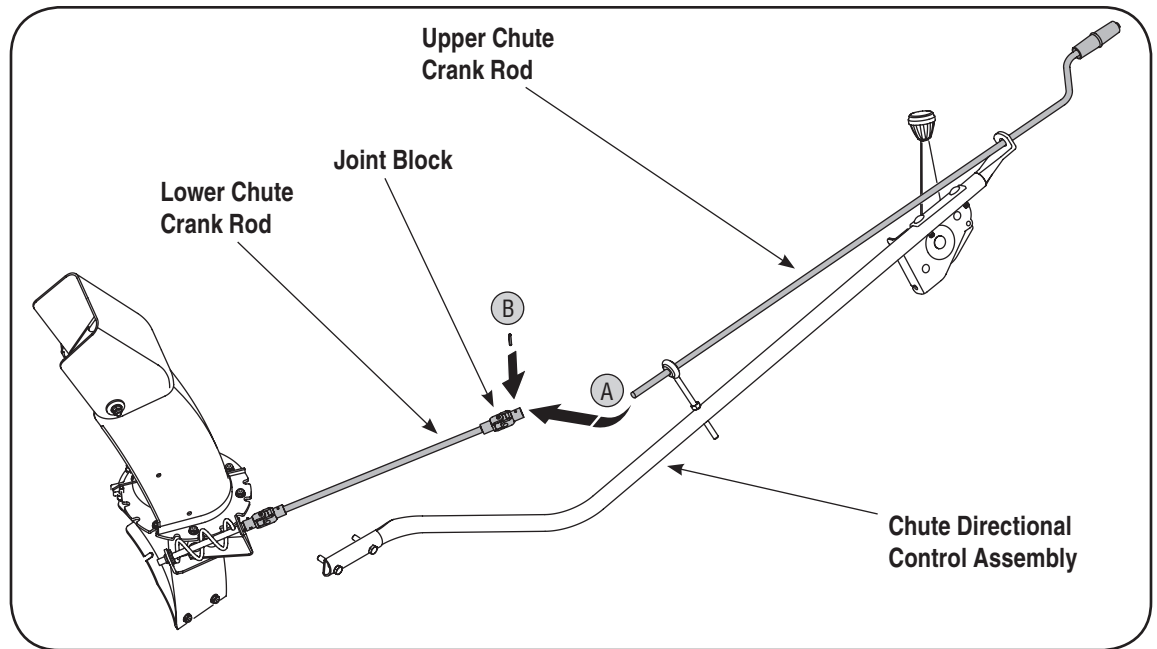

Figure 24

Attaching the Chute Directional Control

1. Secure the upper chute crank rod to the joint block (A) on the lower chute crank rod with the cotter pin (B) provided. See Figure 24.
2. Attach the chute directional control assembly to the upper lift link on the left side of the auger housing assembly with two hex screws as illustrated in Figure 25. Secure with two flange nuts.
3. Fasten the chute tilt cables to the chute directional control with two of the cable ties provided. Pull the cable ties until they're snug and trim off excess.

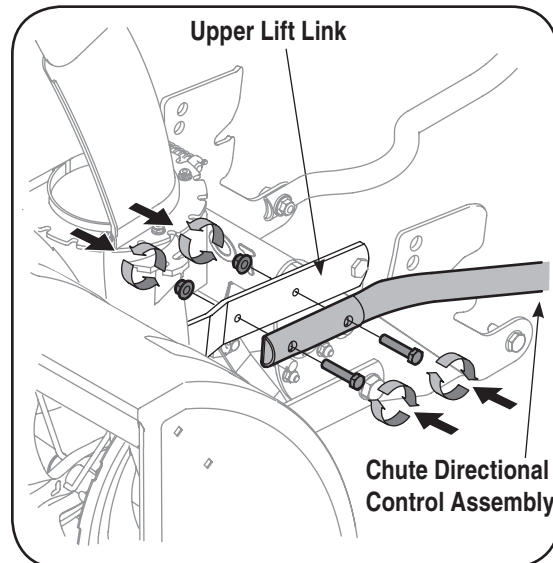

Figure 25

Attaching The Lift Handle

1. Attach the lift handle to the lift bracket on the right side of the auger housing assembly with the two hex screws and two flange nuts provided. See Figure 26.
2. Fasten the lift cable to the lift handle with two of the cable ties provided. Pull the cable ties until they're snug and trim off any excess.

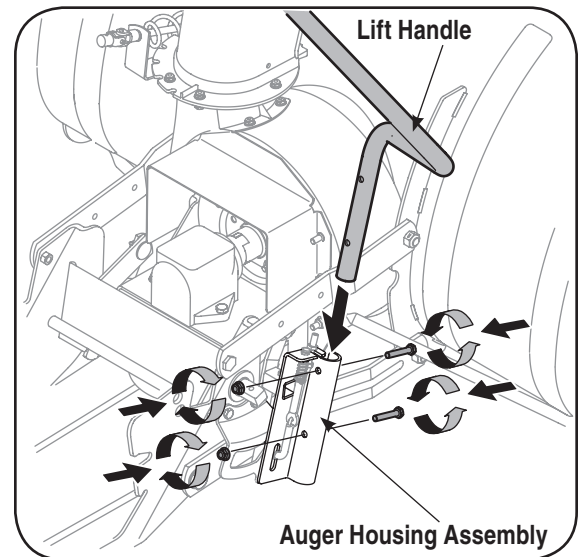

Figure 26

Attaching the Reflectors

Peel off the backing from each of the reflectors to expose the adhesive surface. Adhere the reflectors to the rear of the tractor's fender (one on the left and one on the right) so that the reflectors simulate taillights.

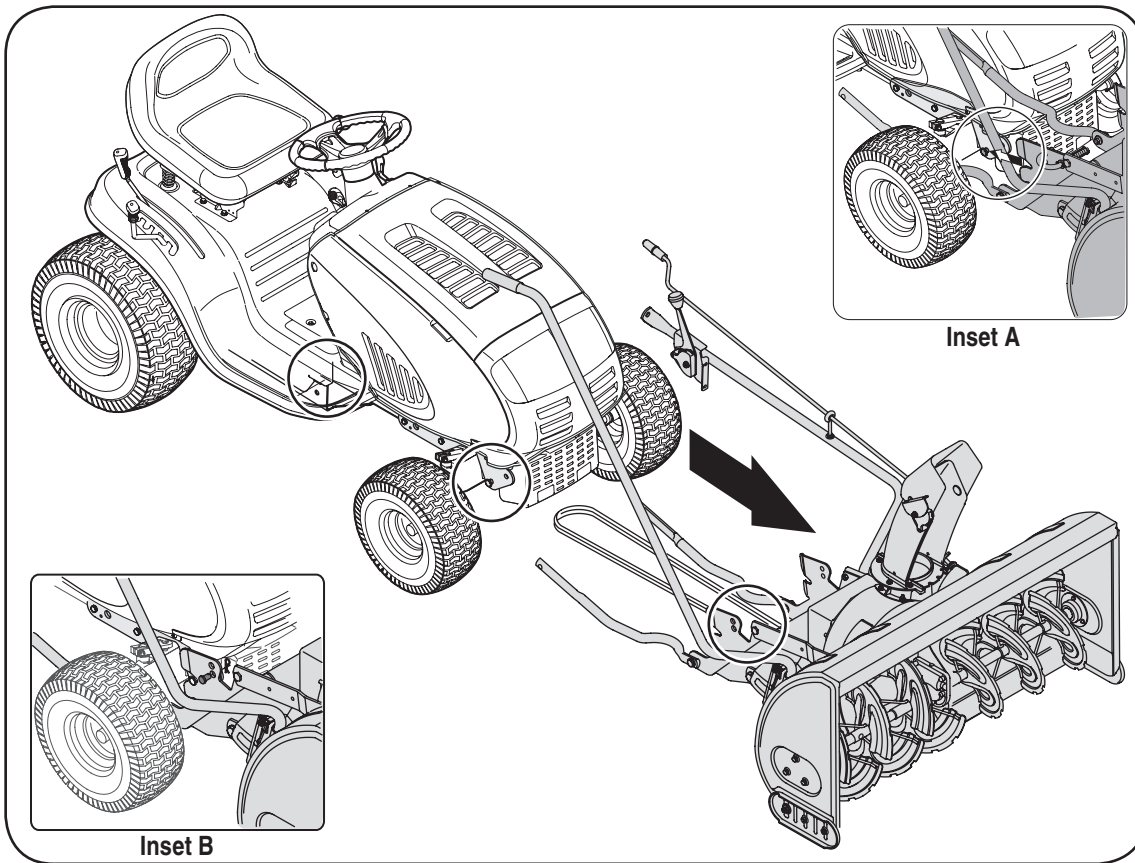

Figure 27

Mounting Auger Assembly

1. Position the auger housing assembly in front of the tractor as seen in Figure 27. Lay the belt and support tubes out as seen above.

IMPORTANT: If you are installing this snow thrower attachment on any mower model with a letter designation (i.e. 60R or 80R, 80T, etc.) then the heat shield on the auger housing must be removed. Do not remove this heat shield on any other model of mower. To determine your model number, see page 2-3 of this manual.

IMPORTANT: It will be necessary to have a second person assist you to complete the following steps.



2. Carefully move the tractor forward (by pushing, NOT driving it) so that the support tubes found on the rear of the auger housing assembly are positioned between the tractor's front tires. Set the parking brake.

WARNING: Before installing attachment, place tractor on a firm and level surface. Place the PTO in the disengaged (OFF) position, set the parking brake, shut engine off and remove key to prevent unintended starting.

3. With the help of an assistant, lift up the auger housing up and move the attachment back aligning the hooks found on the rear of the lift assembly over the shoulder bolts found on both the left and the right sides of the tractor's front pivot support brackets. See Figure 27 Inset A.

4. Maneuver the auger housing until the mounting holes lineup. Insert a clevis pin from your hardware pack and secure with a click pin, into the tractor's front pivot support brackets seen in Figure 27 Inset B.
5. Repeat Step 4 on the left side, inserting a clevis pin secured with a click pin.

Attaching the Support Tubes

1. Secure the right support tube to the front of the undercarriage assembly with the clevis pin and hairpin clip removed earlier. See Figure 28.
2. Repeat the previous step on the left side.

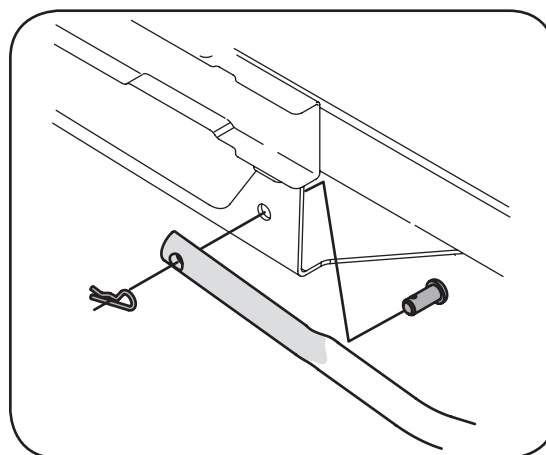

Figure 28

7

Mounting Auger Housing All Models



WARNING

Before installing attachment, place tractor on a firm and level surface. Place the PTO in the disengaged (OFF) position, set the parking brake, shut engine off and remove key to prevent unintended starting.

8

Belt Routing Various Models



WARNING

Before installing attachment, place tractor on a firm and level surface. Place the PTO in the disengaged (OFF) position, set the parking brake, shut engine off and remove key to prevent unintended starting.

IMPORTANT:

Make certain that the flat side of the belt is facing outward. This allows the “V” side of the belt to ride snugly in both pulleys.

Routing the Upper Drive Belt (*Tractors Models with an Electric PTO*)

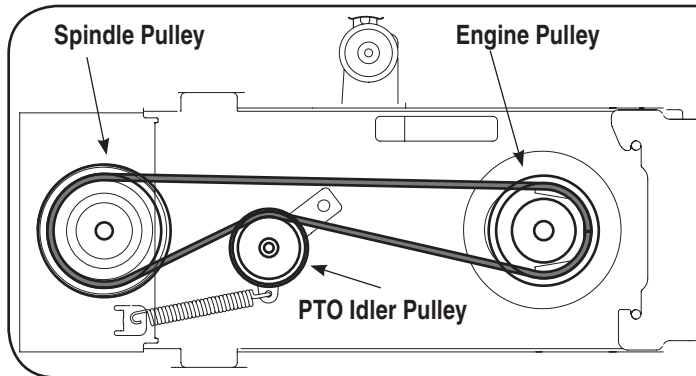

All electric PTO
Decks 42, 46, 50, 54

Figure 29

1. Attach and route the upper drive belt around the spindle pulley and idler pulley found on the undercarriage, the electric PTO clutch and the PTO idler pulley as illustrated in Figure 29. Make sure that the belt is routed to the INSIDE of the belt keeper on the undercarriage idler pulley and the remaining keeper pins found around the spindle pulley.

IMPORTANT: Make certain that the flat side of the belt is facing outward as it sits against both the electric PTO clutch and spindle pulley. This allows the “V” side of the belt to ride snugly in both pulleys.

Routing the Upper Drive Belt (*Tractor Models 700 Series; and 600 Series 2005 & newer cable drive PTO*)

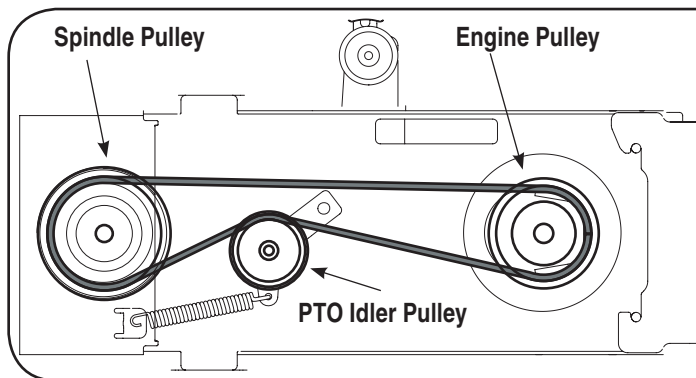

All Manual PTO
Decks 38 & 42

Figure 30

1. Attach and route the upper drive belt around the engine pulley and spindle pulley, routed to the INSIDE of the PTO idler pulley on the undercarriage. Make sure the belt is routed inside of the belt keeper pins found around the spindle pulley and engine pulley. See Figure 30.

IMPORTANT: Make certain that the flat side of the belt is facing outward. This allows the “V” side of the belt to ride snugly in both pulleys.

Routing the Upper Drive Belt (Older Style Tractors)

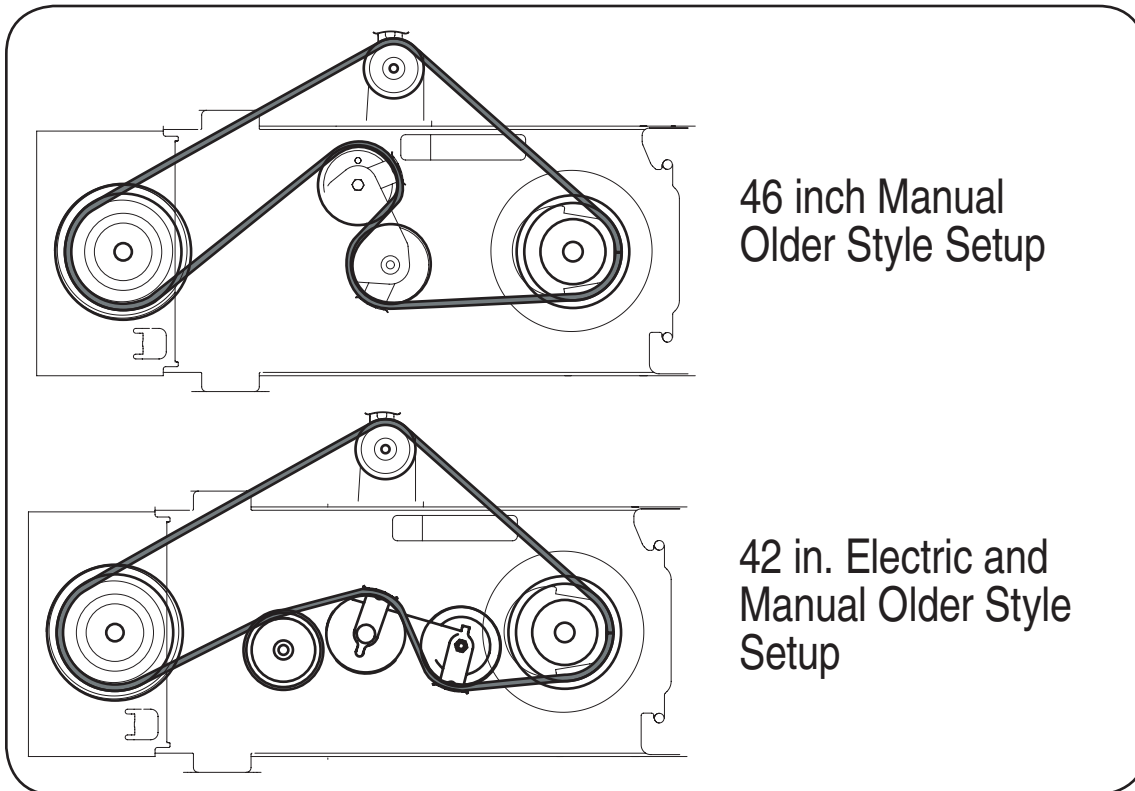

Figure 31

1. Attach and route the proper upper drive belt (refer to the table on page 12) around the spindle pulley and idler pulley found on the undercarriage, the lower portion of the engine pulley and the two pulleys found on the PTO double-idler bracket as illustrated in Figure 31. Make sure that the belt is routed to the **INSIDE** of all belt keepers on the idler pulleys and the keeper pins found around the spindle pulley

IMPORTANT: Make certain that the flat side of the belt is facing outward. This allows the “V” side of the belt to ride snugly in both pulleys.

Routing the Lower Drive Belt (All Tractors Models)

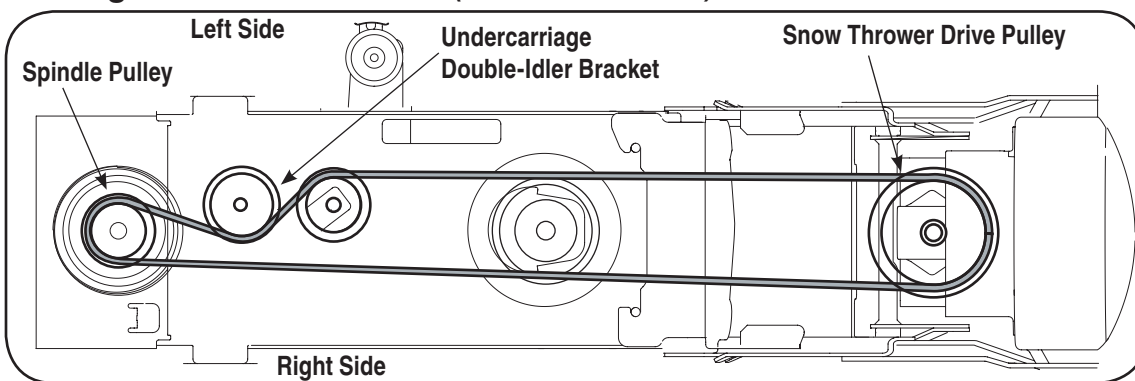

Figure 32

1. Attach and route the lower drive belt around the lower pulley on the spindle assembly, both pulleys on the double-idler bracket found beneath the undercarriage, and the drive pulley found on the rear of the snow thrower housing as illustrated in Figure 32.
2. Attach the tension spring (found on the undercarriage double-idler bracket) to the hex screw if it is not already attached.

8

Belt Routing Various Models



WARNING

Before installing attachment, place tractor on a firm and level surface. Place the PTO in the disengaged (OFF) position, set the parking brake, shut engine off and remove key to prevent unintended starting.

IMPORTANT:

Make certain that the flat side of the belt is facing outward. This allows the “V” side of the belt to ride snugly in both pulleys.

9

Controls



WARNING

Be familiar with all controls and their proper operation. Know how to stop the machine and disengage them quickly.



NOTE:

The PTO knob (on units so equipped) cannot be in the engaged (ON) position when the tractor is driving in the reverse direction. The PTO knob must be in the disengaged (OFF) position when the shift lever is placed in REVERSE or the electric PTO clutch will automatically shut off.



WARNING: Be familiar with all controls and their proper operation. Know how to stop the machine and disengage them quickly.

Engaging the Augers and Impeller

Power to the snow thrower attachment is activated by engaging the tractor's PTO.

1. Place the tractor's throttle control in the FAST (rabbit) position and allow it to remain there for efficient snow removal.
2. Move the PTO knob or PTO lever (on tractor's so equipped) into the "ON" position to engage the augers and impeller.
3. Move the PTO knob or PTO lever (on tractor's so equipped) into the "OFF" position to disengage the augers and impeller.

NOTE: The PTO knob (on units so equipped) cannot be in the engaged (ON) position when the tractor is driving in the reverse direction. The PTO knob must be in the disengaged (OFF) position when the shift lever is placed in REVERSE or the electric PTO clutch will automatically shut off.

Refer to your tractor's Operator's Manual for more information regarding your tractor's PTO and safety interlock system.

Lift Handle

The lift handle is located on the right side of the tractor and is used to raise and lower the snow thrower attachment.

1. To raise the snow thrower attachment off of the ground, pull rearward and down on the lift handle until you feel the lift latch on the right side of the snow thrower engage, locking the snow thrower in a raised position.
2. To lower the snow thrower, push downward on the lift handle until there is enough slack in the lift cable so that you may squeeze the trigger control. With the trigger control squeezed, gently allow the snow thrower to lower until it reaches the ground.

Chute Directional Control

The chute directional control assembly is found on the left side of the tractor and includes both the chute tilt lever as well as the chute crank. Both affect the direction that the discharged snow is thrown.

To pivot the upper section of discharge chute, affecting the distance and angle which the snow is thrown, move the chute tilt lever forward or rearward into a desired position.

The direction which snow is thrown can be changed by rotating the discharge chute with the chute crank. Turn the chute crank clockwise to rotate the chute and discharge snow to the left. Crank it counterclockwise to rotate the chute and discharge snow to the right.

OPERATION



WARNING: Read, understand, and follow all instructions and warnings on the tractor, attachment, and in the Operator's Manuals before operating.

Your snow thrower attachment is capable of displacing snow and clearing a path a width of 42 inches.

Observe the following operating instructions for efficient snow removal.

1. Become familiar with and comfortable using all of your tractor's controls as instructed in your tractor's Operator's Manual before operating it with the snow thrower attachment.
2. Make certain the correct weight (and volume) of motor oil in is your tractor's engine as instructed in the engine Owner's Guide packed with the tractor's Operator's Manual.
3. Always operate the snow thrower with the tractor's engine at maximum RPM (full throttle).
4. NEVER override any safety features on either your tractor or the snow thrower attachment.
5. Make certain that all nuts, bolts, and hardware are fastened securely and tight on both the tractor and the snow thrower attachment prior to use.
6. Make certain the snow thrower is assembled properly and mounted to the tractor as instructed in this manual.
8. Test all the controls (tractor PTO, snow thrower lift handle, chute tilt lever & chute crank) for smooth operation prior to operating the snow thrower in snow.
9. Make all adjustments (i.e. skid shoes, lift latch) before operating your snow thrower attachment. Follow instructions in the Adjustments section of this manual when doing so.
10. Engage the tractor's PTO to activate power to the augers and impeller BEFORE driving the tractor forward and into snow.
11. Keep your tractor's ground-speed slow. The slower your tractor is traveling, the more effectively the snow thrower attachment can displace snow.
12. Adjust ground speed for snow conditions and become familiar with different snow applications. Your snow thrower attachment will operate differently in wet heavy snow than it will in light, fluffy snow.
13. Overlap a previously cleared path when necessary (deep snow) so as not to overload the auger housing with snow.
14. NEVER drive the tractor into a snow bank. The snow thrower attachment is not a dozer plow. The lift linkage and/or the snow thrower drive system can be damaged as a result of "plowing" with the snow thrower attachment.
15. If the augers become jammed with a chunk of ice or

a foreign object, move the PTO into the disengaged (OFF) position immediately and turn off the tractor's engine and remove the ignition key. Examine the auger area thoroughly for damage and do NOT operate the snow thrower attachment until any damage is repaired.

IMPORTANT: The augers are secured to the spiral shaft with two shear bolts and hex lock nuts. If you hit a hard foreign object or an ice jam, the snow thrower is designed so that the bolts may shear. Two replacement shear bolts and hex lock nuts are provided for your convenience. Store in a safe place until needed. NEVER replace the auger shear bolts with standard hex bolts. Any damage to the auger gearbox or other components as a result of doing so will NOT be covered by your snow thrower's warranty.

16. Whenever possible, discharge snow downwind.
17. Do NOT attempt to remove ice or hard-packed frozen snow.
18. When the tractor (with the snow thrower attachment mounted) is not in service, use the lift lever to lower the auger housing assembly to the ground to relieve strain on the tractor's front end between uses.
19. Always use tire chains and rear wheel weights on your tractor where extra traction is needed. Refer to the table to the right to determine which kits will fit your tractor (tire dimensions are can be found on the sidewalls of your tractor's tires).
20. Use drift cutters to aid in displacing snow through deep, drifted areas.

Tire Chain Kit Number

Garden Tractors

23" x 9.5" tires	OEM-190-964
22" x 7.5" tires	OEM-190-974

Lawn Tractors

20" x 10.0" tires	OEM-190-916
20" x 8.0" tires	OEM-190-658
18" x 9.5" tires	OEM-190-657
18" x 8.5" tires	OEM-190-754
18" x 6.5" tires	OEM-190-664

Wheel Weight Kit Number

All Garden Tractors	OEM-190-784
All Lawn Tractors	OEM-190-215

Drift Cutter Kit Number

All Tractors	OEM-390-679
--------------	-------------

NOTE: None of the kits in the table are included as standard equipment with snow thrower attachment OEM-190-032. Call our Customer Support Department as instructed on page 2 of this manual for availability and information regarding these kits.

10

Operation



WARNING

Read, understand, and follow all instructions and warnings on the tractor, attachment, and in the Operator's Manuals before operating.

IMPORTANT:

The augers are secured to the spiral shaft with two shear bolts and hex lock nuts. If you hit a hard foreign object or an ice jam, the snow thrower is designed so that the bolts may shear. Two replacement shear bolts and hex lock nuts are provided for your convenience. Store in a safe place until needed. NEVER replace the auger shear bolts with standard hex bolts. Any damage to the auger gearbox or other components as a result of doing so will NOT be covered by your snow thrower's warranty.

11

Adjustments All Models



WARNING

Never attempt to make any adjustments while the engine is running, except where specified in the Operator's Manual. Place tractor on a firm and level surface. Place the PTO in the disengaged (OFF) position, set the parking brake, shut engine off, and remove key to prevent unintended starting.

Making Adjustments



WARNING: Never attempt to make any adjustments while the engine is running, except where specified in the Operator's Manual. Place tractor on a firm and level surface. Place the PTO in the disengaged (OFF) position, set the parking brake, shut engine off, and remove key to prevent unintended starting.

Lift Adjustment

If the lift index rod doesn't latch securely or the pivot release has too much slack in it, an adjustment can be made as follows:

1. Loosen the upper hex nut a few turns, then tighten the lower hex nut to shorten the cable length. See Figure 33.
2. Loosen the lower hex nut a few turns, then tighten the upper hex nut to lengthen the cable. See Figure 33.

Lower Chute Crank Support Bracket Adjustment

If the spiral at the base of the lower chute crank isn't fully engaging with the notches in the lower chute assembly, the support bracket can be adjusted inward or outward as follows:

1. Loosen, but do NOT remove the two hex nuts which secure the support bracket to the snow thrower housing. See Figure 34.
2. Adjust the support bracket inward or outward so that the spiral is fully engaged in the notches on the chute before retightening the hex nuts.

Skid Shoe Adjustment

The space between the shave plate and the ground can be adjusted by repositioning the skid shoes found on either side of the snow thrower's auger housing. For close snow removal, place skid shoes in the low position. Use a middle or high position when the area to be cleared is uneven.

IMPORTANT: It is NOT recommended that this snow thrower be operated on a gravel surface, as loose stones can be easily picked up and thrown by the machine. If you must operate on a gravel surface, ALWAYS adjust the skid shoes into the HIGH position to allow the shave plate maximum clearance.

Adjust skid shoes as follows:

1. Loosen, but do NOT remove, the three hex nuts which fasten the skid shoe to the auger housing. See Figure 35.

2. Raise or lower the skid shoe to desired position.

NOTE: Make certain the entire base of both skid shoes are against the ground to avoid uneven wear on the skid shoes. When one side does wear out, the skid shoes are reversible.

3. Retighten the hex nuts loosened earlier.

4. Repeat this adjustment on the skid shoe found on the opposite side of the snow thrower.

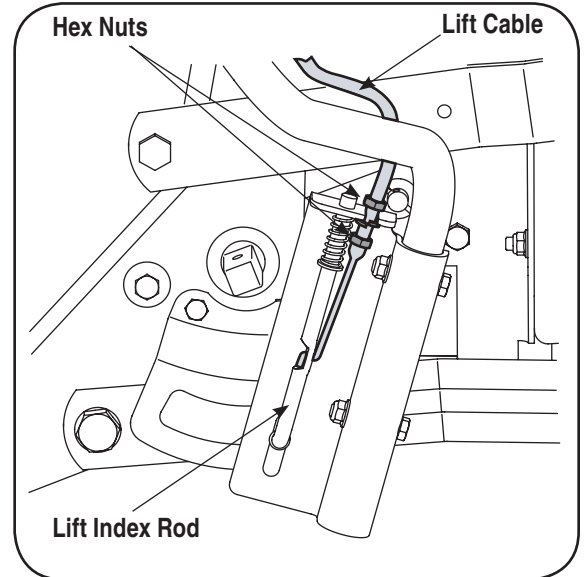

Figure 33

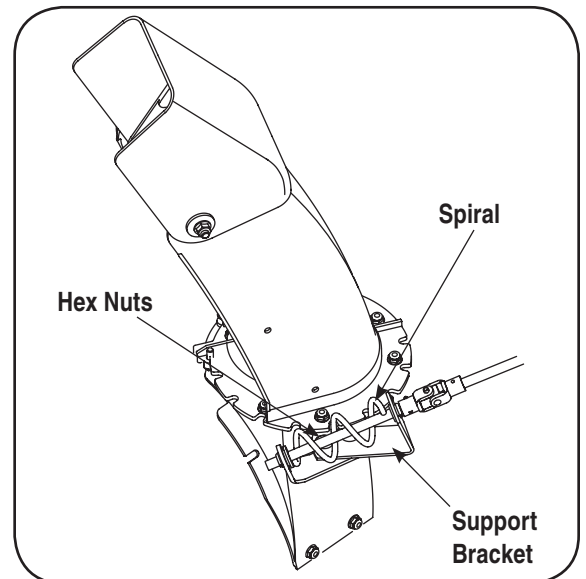

Figure 34

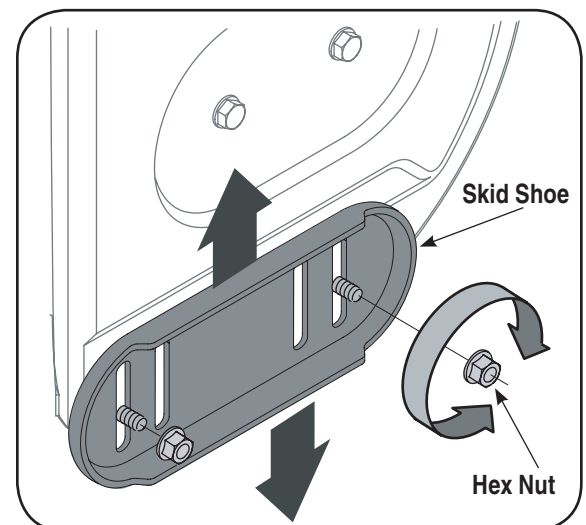

Figure 35

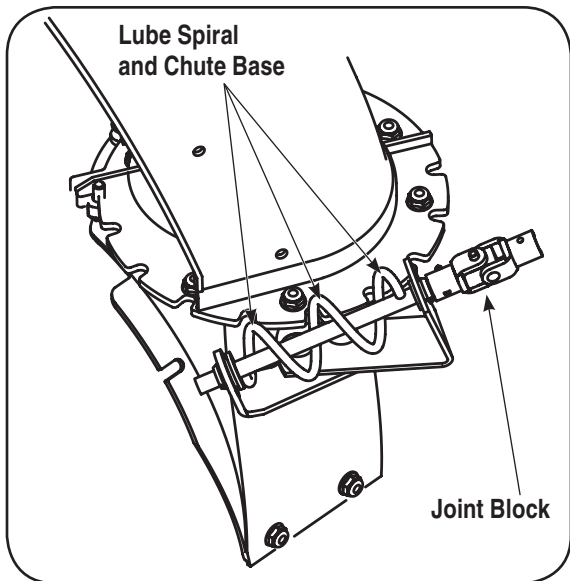

Figure 36

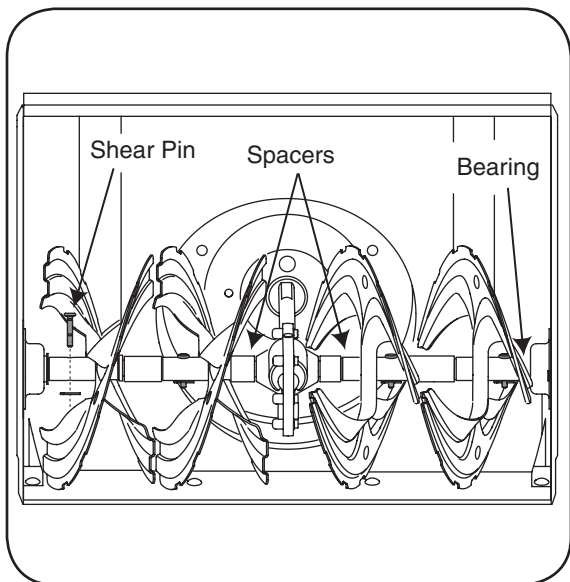

Figure 37

Maintenance



WARNING: Before lubricating, repairing, or inspecting, place tractor on a firm and level surface. Place the PTO in the disengaged (OFF) position, set the parking brake, shut engine off, and remove key to prevent unintended starting.

Lubrication of Chute Directional Control

The spiral on the end of the lower chute crank, the base of the discharge chute itself and the joint blocks which connect the lower and upper chute cranks should be lubed with multi-purpose automotive grease once a season. See Figure 36.

Auger Shaft

1. At least once a season, remove the shear bolts on the auger shaft. Oil or spray lubricant inside and on the plastic bearings on the shaft and near the holes where the shear bolts were removed before reattaching them. See Figure 37.

12

Maintenance All Models



WARNING

Before lubricating, repairing, or inspecting, place tractor on a firm and level surface. Place the PTO in the disengaged (OFF) position, set the parking brake, shut engine off, and remove key to prevent unintended starting.

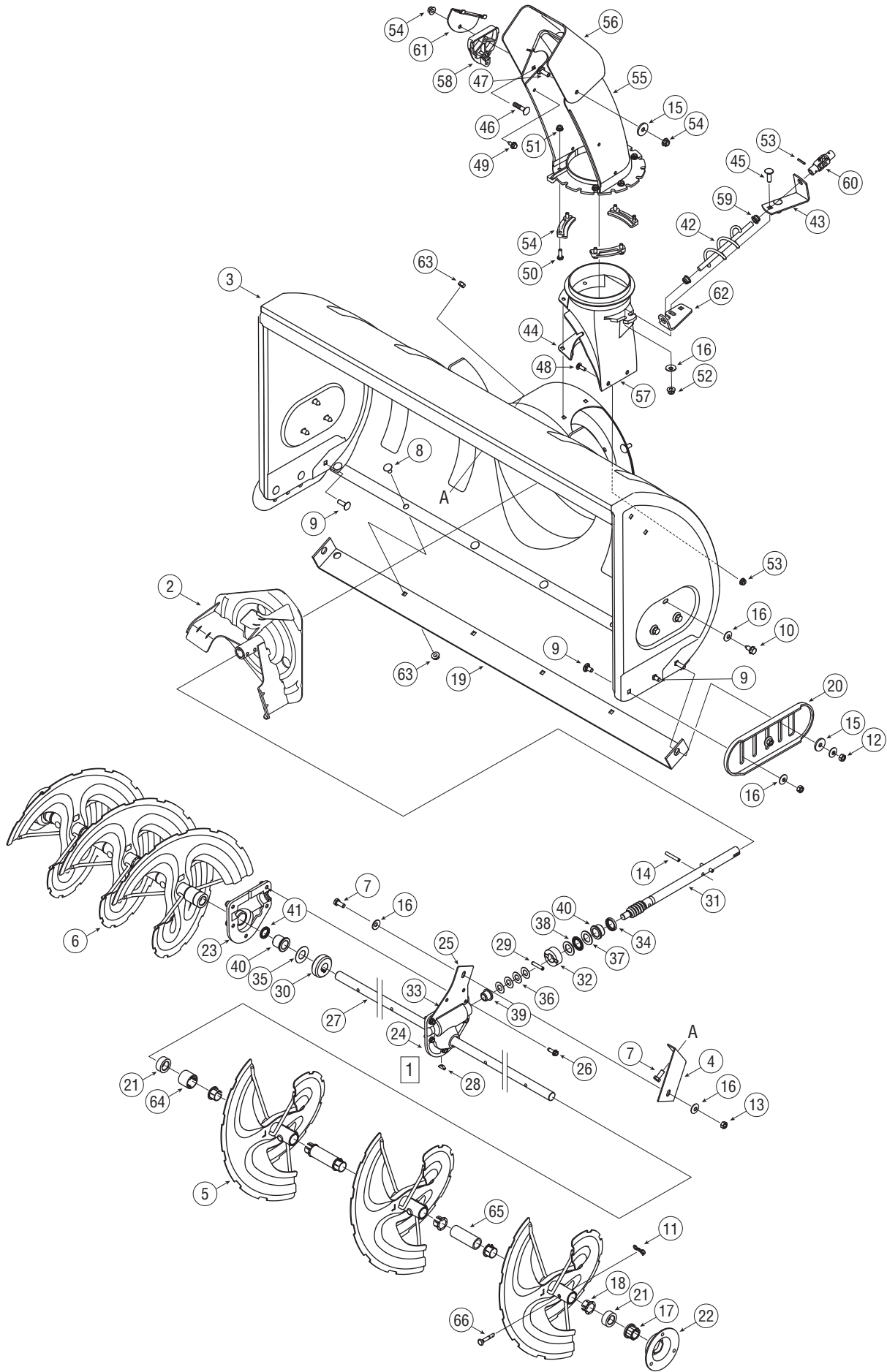

13

Part List: Snow Thrower Attachment



*For parts and/or
accessories
please call
1-800-800-7310, or
1-330-220-4683.
www.mtdproducts.com*

NOTE:

For painted parts, please refer to the list of color codes below. Please add the applicable color code, wherever needed, to the part number to order a replacement part.

For instance, if a part numbered 700-xxxx is painted powder black, the part number to order would be 700-xxxx-0637.

Yardman Green - 0665
Black - 0637

REF NO.	PART NUMBER	DESCRIPTION	Qty	REF NO.	PART NUMBER	DESCRIPTION	Qty.
1	618-04315	Auger Gear Box (Incl. Ref. 23-41)	1	34	721-0327	Grease Seal	1
2	684-0158	Impeller Assembly, 12"	1	35	736-0351	Flat Washer, .76 x 1.5 x .030	2
3	684-0148	Housing Assembly	1	36	736-0369	Flat Washer, .508 x 1.0 x .020	4
4	703-2734	Housing Brace Bracket	1	37	736-0617	Thrust Washer, .75 x 1.25 x .0615	2
5	684-04163	LH Spiral Auger	3	38	741-0150	Thrust Bearing, .75 x 1.25 x .078	1
6	684-04164	RH Spiral Auger	3	39	748-0108	Flange Bearing, .503 x .75	1
7	710-0157	Hex Cap Screw, 5/16-24 x .75	2	40	741-0700	Flange Bearing, .75 x 1.0 x .59	1
8	710-0260A	Carriage Bolt, 5/16-18 x .62	10	41	721-0179	Grease Seal	2
9	710-0276	Splined Carriage Screw	2	42	684-0061	Chute Crank Assembly	1
10	710-0726	Self Tapping Screw	8	43	703-2735A	Chute Crank Bracket	1
11	714-04040	Bow-Tie Cotter Pin	8	44	705-5226	Chute Reinforcer	1
12	712-3010	Hex Nut, 5/16-18	6	45	710-0276	Splined Carriage Screw	2
13	712-3057	Hex Nut, 5/16-24	2	46	710-0262	Carriage Bolt, 5/16-18 x 1.5	1
14	715-0114	Spirol Pin, 1/4 x 1-1/2	2	47	710-04071	Carriage Screw, 5/16-18 x 1.0	1
15	736-0231	Flat Washer, .344 x 1.125 x .12	3	48	710-0703	Screw, 1/4-20 x .75	4
16	736-0242	Bell Washer, .340 x .872	17	49	710-0896	Hex Index Washer Screw	1
17	741-0245	Hex Flange Bearing, .75 ID	2	50	710-3015	Hex Cap Screw, 1/4-20 x .75	6
18	741-0493A	Flange Bushing, .80 x .91	12	51	712-04064	Nylon Hex Lock Nut, 1/4-20	10
19	784-0396A	Skid Plate Bracket, 42"	1	52	712-04063	Nylon Hex Lock Nut, 5/16-18	5
20	784-5038B	Slide Shoe	2	53	715-0129	Spirol Pin, .125 x .82	1
21	711-0469	Spacer, .75 x .125 x .5	4	54	731-0851A	Chute Flange Keeper	3
22	784-5618	Hex Bearing Housing, 1.0	2	55	731-1300D	Lower Chute	1
23	618-0123	RH Reducer Housing	1	56	731-1320	Upper Chute	1
24	618-0124	LH Reducer Housing	1	57	731-1379D	Adapter Chute	1
25	703-2733A	Housing Brace Plate	1	58	731-1313C	Chute Tilt Cable Guide	1
26	710-0642	Self Tapping Screw, 1/4-20 x .75	5	59	741-0475	Plastic Bushing	2
27	711-04468	Spiral Axle, 41.5"	1	60	784-5149	Joint Block Assembly	1
28	714-0161	Hi-Pro Key, 3/16 x 5/8	1	61	784-5594	Cable Bracket	1
29	715-0143	Spring Spirol Pin, .25 x 1.25	1	62	784-5647	Chute Crank Bracket	1
30	717-0528A	Worm Gear, 20-tooth	1	63	712-3004A	Flange Lock Nut, 5/16-18	6
31	717-3320	Worm Shaft	1	64	731-04870	Spacer 1.25 x .75 x 1.00	2
32	718-0513	Thrust Collar	1	65	731-1086A	Sleeve .758 x 1.00 x 2.70	4
33	721-0325	Grease Plug	1	66	738-04124	Shear Pin, .25 x 1.50	8

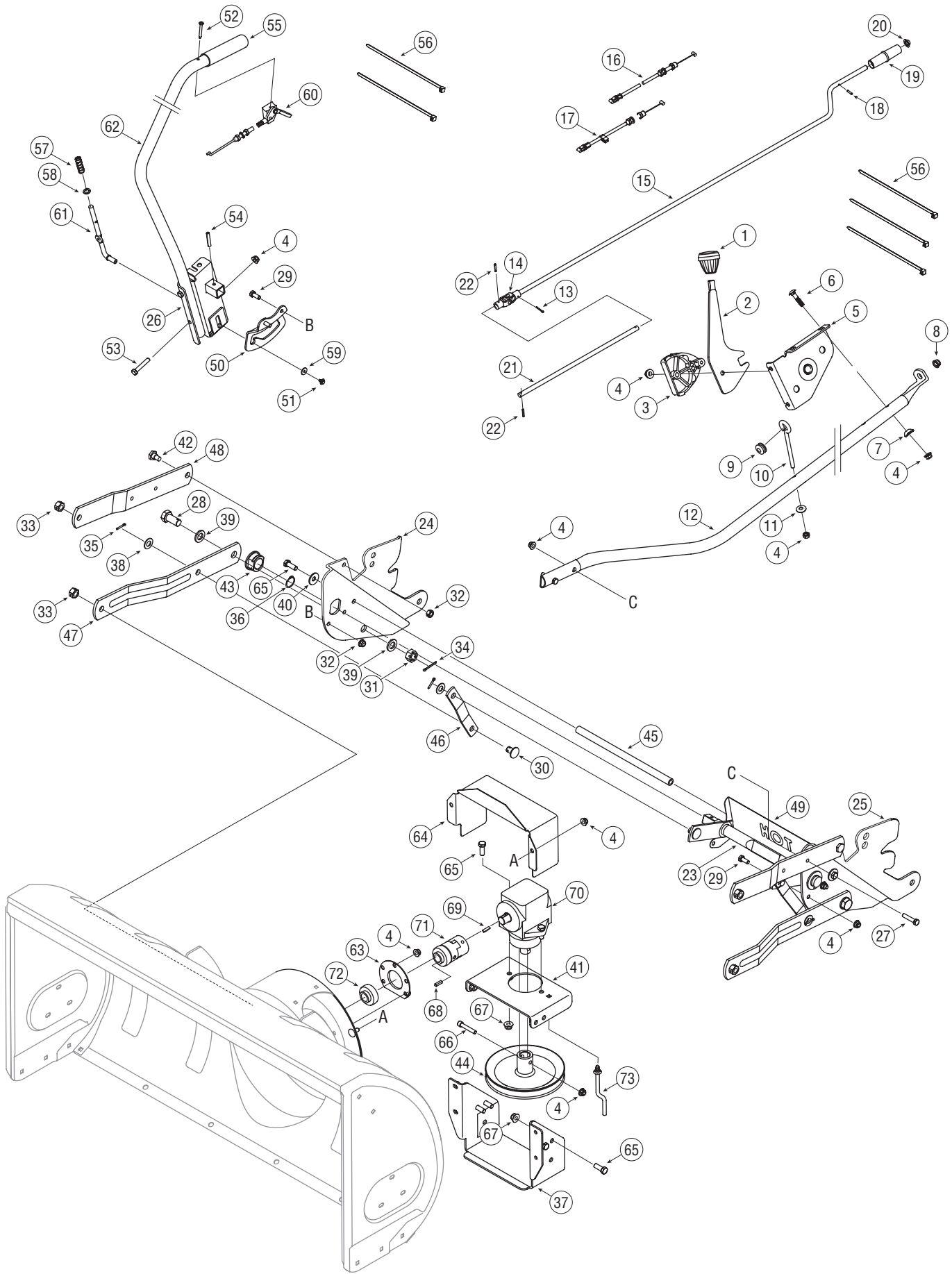

13

Part List: Snow Thrower Attachment



*For parts and/or
accessories
please call
1-800-800-7310, or
1-330-220-4683.
www.mtdproducts.com*

REF NO.	PART No.	DESCRIPTION	Qty.	REF NO.	PART No.	DESCRIPTION	Qty.
1	720-0232	Knob	1	38	736-0272	Flat Washer, .51 x 1.0 x .060	4
2	784-5604	Chute Tilt Handle	1	39	736-0366	Flat Washer, .64 x 1.12 x .125	4
3	731-1313C	Chute Tilt Cable Guide	1	40	736-0452	Bell Washer, .396 x 1.14 x .095	2
4	712-04063	Nylon Hex Lock Nut, 5/16-18	22	41	783-1014A	Drive Mounting Bracket	1
5	603-0302	Chute Tilt Bracket Assembly	1	42	738-0234	Shoulder Screw, .5 x .29, 3/8-16	2
6	710-0262	Carriage Bolt, 5/16-18 x 1.5	2	43	741-0170	Flange Bearing w/ Flats	2
7	736-0451	Saddle Washer, .32 x .93	2	44	756-1181A	Drive Pulley, 7"	1
8	741-0475	Plastic Bushing	1	45	747-1192	Rod, 1/2 x 11.55	1
9	735-0234	Rubber Grommet, .44 x .94 x .5	1	46	783-0876	Link, 5.875	2
10	747-0697	Eye Bolt	1	47	783-0877	Link, 15.4	2
11	736-0242	Bell Washer, .340 x .872	1	48	783-0878	Link, 13.35	2
12	750-04467	Support Chute Tube	1	49	783-1274B	Heat Shield	1
13	714-0507	Cotter Pin, 3/32 x .75	1	50	790-00110	Snow Thrower Lift Bracket	1
14	784-5149	Joint Block Assembly	1	51	710-1268	Hex Index Washer Screw #10-16	1
15	747-1201	Chute Crank Rod, .375 x 33	1	52	710-3143	Pan Phillips Screw, #10-24 x .75	1
16	746-1108	Chute Cable, 62"	1	53	710-3180	Hex Cap Screw, 5/16-18 x 1.75	2
17	746-1109	Chute Cable w/ Clip, 62"	1	54	715-0114	Heavy Duty Spirol Pin, 1/4 x 1.5	1
18	715-0138	Rolled Pin, 1/8 x .63	1	55	720-0274	Handle Grip	1
19	720-0201A	Crank Knob	1	56	725-0157	Cable Tie	5
20	726-0100	Push Cap, 3/8 ID	1	57	732-0306	Compression Spring	1
21	747-04400	Rod, .375 x 11.375	1	58	736-0140	Flat Washer, .385 x .62 x .063	1
22	715-0129	Spirol Pin, .125 x .82	2	59	736-0400	Flat Washer, .194 x .62 x .063	1
23	611-0132A	Rod Assembly	1	60	746-1103A	Lift Cable, 42" w/ Trigger Control	1
24	783-0880C	RH Support Plate Assembly	1	61	747-1203	Lift Index Rod	1
25	783-0879C	LH Support Plate Assembly	1	62	750-1221	Lift Handle Tube	1
26	683-04150	Lift Bracket Assembly	1	63	05931A	Bearing Housing, 1.85 ID	1
27	710-0805	Hex Cap Screw, 5/16-18 x 1.50	2	64	703-2736	Belt Cover	1
28	710-0964A	Hex Cap Screw, 5/8-18 x 1.31	2	65	710-0514	Hex Cap Screw, 3/8-16 x 1.0	8
29	710-3008	Hex Cap Screw, 5/16-18 x .75	4	66	710-3251	Socket Head Cap Screw	1
30	711-0332	Clevis Pin, .5 x .78	2	67	712-04065	Flange Lock Nut, 3/8-16	6
31	712-0386A	Slotted Hex Nut, 5/8-18	2	68	714-0122	Square Key, 3/16 x .75	1
32	712-3000	Hex Lock Nut, 3/8-16	4	69	714-0126	Hi-pro Key, 3/16 x .75	1
33	712-3022	Hex Lock Nut, 1/2-13	4	70	717-1714A	Right Angle Drive	1
34	714-0470	Cotter Pin, 1/8 x 1.25	2	71	718-0691	Coupling	1
35	714-0474	Cotter Pin, .125 x .75	4	72	741-0309	Flange Ball Bearing, .75 x 1.85	1
36	716-0102	Snap Ring	1	73	747-1257	Belt Keeper Rod	1
37	784-0402	Skid Plate	1				

* Refer to the table on page 6 for your tractor's applicable upper v-belt.

13

Part List: Snow Thrower Attachment



**For parts and/or
accessories
please call
1-800-800-7310, or
1-330-220-4683.
www.mtdproducts.com**

REF NO.	PART No.	DESCRIPTION	Qty.	REF NO.	PART No.	DESCRIPTION	Qty.
1	618-0411	Spindle Assembly (Incl. 38-44)	1	33	712-0241	Hex Nut, 3/8-24	1
2	683-04210	Pulley Mounting Bracket	1	34	732-0978	Extension Spring, .620 x 5.62	1
3	710-0347	Hex Cap Screw, 3/8-16 x 1.75	2	35	736-0169	Lock Washer, 3/8	1
4	710-1260A	Self Tapping Screw	4	36	756-0487	Idler pulley, 4" Diameter	1
5	711-0310	Clevis Pin, .5 x 1.18	2	37	784-5727	Idler Pivot Arm	1
6	711-1000	Belt Keeper Pin †	4	38	712-0417	Flange Nut 5/8-18	2
7	711-1421	Clevis Pin, 3/8 x .75	2	39	741-0919	Ball Bearing	2
8	712-04063	Nylon Hex Lock Nut, 5/16-18	4	40	750-1096	Spacer	1
9	712-04064	Nylon Hex Lock Nut, 1/4-20 †	4	41	619-0044	Deck Spindle Housing	1
10	712-04065	Hex Flange Lock Nut, 3/8-16	11	42	756-0999	Deck Pulley 7"	1
11	712-3010	Hex Nut, 5/16-18	1	43	756-1173	Pulley 3.75"	1
12	714-0145	Click Pin, .092 x 1.64	7	44	738-0976	Spindle Shaft	1
13	714-0147	Internal Cotter Pin, .125 x 1.75	2	45	683-04215	Snow Thrower Support Brackets LH †	1
14	732-04168	Belt Guard	1	46	683-04214	Snow Thrower Support Brackets RH †	1
15	736-0192	Flat Washer, .531 x .93 x .09	2	47	738-0143	Shoulder Screw †	2
16	736-3072	Flat Washer, .38 x .93 x .11	4	48	710-0514	Hex Head Screw 3/8-16 x 1.00 †	4
17	738-0145	Shoulder Screw, 3/8-16	2	49	732-04237	Extension Spring .50 x 12.00	1
18	738-0347	Shoulder Spacer, .625 x .169	2	50	726-0354	Clamp 16mm †	1
19	749-1103	LH Support Tube	1	51	754-0498	V-Belt †	1
20	749-1104	RH Support Tube	1	52	754-0435	Upper V-belt*	1
21	712-0298	Hex Lock Nut, 1/4-20	1	53	754-0481	Upper V-belt*	1
22	736-0270	Bell Washer.265 x .75 x .062	1	54	754-0371A	Upper V-belt*	1
23	712-3006	Hex Nut 1/4-20	1	55	754-0125A	V-Belt	1
24	747-04135	Belt Keeper Rod	1	56	710-3180	Hex Cap Screw, 5/16-18 x 1.75	1
25	756-0627D	Idler Pulley 3.50 dia.	3	57	756-04224	Idler Pulley, Flat 2.75 OD	1
26	650-0040	Idler Assembly Spacer	1	58	710-04511	Pin 5/16-18	1
27	712-0431	Flange Lock Nut 3/8-16	1	59	712-04100	Wing Nut 5/16-18 †	1
28	783-1291	Idler Bracket	1	60	730-3000	Reflector	2
29	710-0151	Hex Cap Screw, 3/8-24 x 2	1	61	684-0149	Double Idler Bracket Assembly	1
30	710-0521	Hex Cap Screw, 3/8-16 x 3	1	62	732-0594A	Extension Spring .91 x 7.33	1
31	711-0242	Spacer	3	63	754-0490	V-Belt	1
32	712-0116	Nylon Jam Lock Nut, 3/8-24	1	64	736-3010	Flat Washer	

* Refer to the table on page 6 for your tractor's applicable upper v-belt.

† Used only on the model 700-799 Series units

14



NOTES:

Use this page to make notes and write down important information.

14



NOTES:

Use this page to make notes and write down important information.

MANUFACTURER'S LIMITED WARRANTY FOR



The limited warranty set forth below is given by MTD LLC with respect to new merchandise purchased and used in the United States, its possessions and territories.

"MTD" warrants this product against defects in material and workmanship for a period of two (2) years commencing on the date of original purchase and will, at its option, repair or replace, free of charge, any part found to be defective in materials or workmanship. This limited warranty shall only apply if this product has been operated and maintained in accordance with the Operator's Manual furnished with the product, and has not been subject to misuse, abuse, commercial use, neglect, accident, improper maintenance, alteration, vandalism, theft, fire, water, or damage because of other peril or natural disaster. Damage resulting from the installation or use of any part, accessory or attachment not approved by MTD for use with the product(s) covered by this manual will void your warranty as to any resulting damage.

Normal wear parts are warranted to be free from defects in material and workmanship for a period of thirty (30) days from the date of purchase. Normal wear parts include, but are not limited to items such as: batteries, belts, blades, blade adapters, grass bags, rider deck wheels, seats, snow thrower skid shoes, shave plates, auger spiral rubber and tires.

HOW TO OBTAIN SERVICE: Warranty service is available, WITH PROOF OF PURCHASE, through your local authorized service dealer. To locate the dealer in your area, check your Yellow Pages, or contact MTD LLC at P.O. Box 361131, Cleveland, Ohio 44136-0019, or call 1-800-800-7310 or 1-330-220-4683 or log on to our Web site at www.mtdproducts.com.

This limited warranty does **not** provide coverage in the following cases:

- a. The engine or component parts thereof. These items may carry a separate manufacturer's warranty. Refer to applicable manufacturer's warranty for terms and conditions.
- b. Log splitter pumps, valves, and cylinders have a separate one year warranty.
- c. Routine maintenance items such as lubricants, filters, blade sharpening, tune-ups, brake adjustments, clutch adjustments, deck adjustments, and normal deterioration of the exterior finish due to use or exposure.
- d. Service completed by someone other than an authorized service dealer.

e. MTD does not extend any warranty for products sold or exported outside of the United States, its possessions and territories, except those sold through MTD's authorized channels of export distribution.

f. Replacement parts that are not genuine MTD parts.

g. Transportation charges and service calls.

No implied warranty, including any implied warranty of merchantability of fitness for a particular purpose, applies after the applicable period of express written warranty above as to the parts as identified. No other express warranty, whether written or oral, except as mentioned above, given by any person or entity, including a dealer or retailer, with respect to any product, shall bind MTD. During the period of the warranty, the exclusive remedy is repair or replacement of the product as set forth above.

The provisions as set forth in this warranty provide the sole and exclusive remedy arising from the sale. MTD shall not be liable for incidental or consequential loss or damage including, without limitation, expenses incurred for substitute or replacement lawn care services or for rental expenses to temporarily replace a warranted product.

Some states do not allow the exclusion or limitation of incidental or consequential damages, or limitations on how long an implied warranty lasts, so the above exclusions or limitations may not apply to you.

In no event shall recovery of any kind be greater than the amount of the purchase price of the product sold. **Alteration of safety features of the product shall void this warranty.** You assume the risk and liability for loss, damage, or injury to you and your property and/or to others and their property arising out of the misuse or inability to use the product.

This limited warranty shall not extend to anyone other than the original purchaser or to the person for whom it was purchased as a gift.

HOW STATE LAW RELATES TO THIS WARRANTY: This limited warranty gives you specific legal rights, and you may also have other rights which vary from state to state.

IMPORTANT: Owner must present Original Proof of Purchase to obtain warranty coverage.