



Service Kit 753-05607

Date: April 17, 2009 (Revised 6/08/2009)

Subject: Hydraulic Cylinder Seal Replacement

Models Affected: XINGHUI 4.5" Cylinder 718-0769A

Read through and understand these instructions completely before proceeding with repair.

NOTE: These materials are prepared for use by trained technicians who are experienced in the service and repair of equipment of the kind described in this publication, and are not intended for use by untrained or inexperienced individuals. Such individuals should seek the assistance of an authorized service technician or dealer.

NOTE: Save this Instruction Sheet. Refer to it when ordering replacement parts.

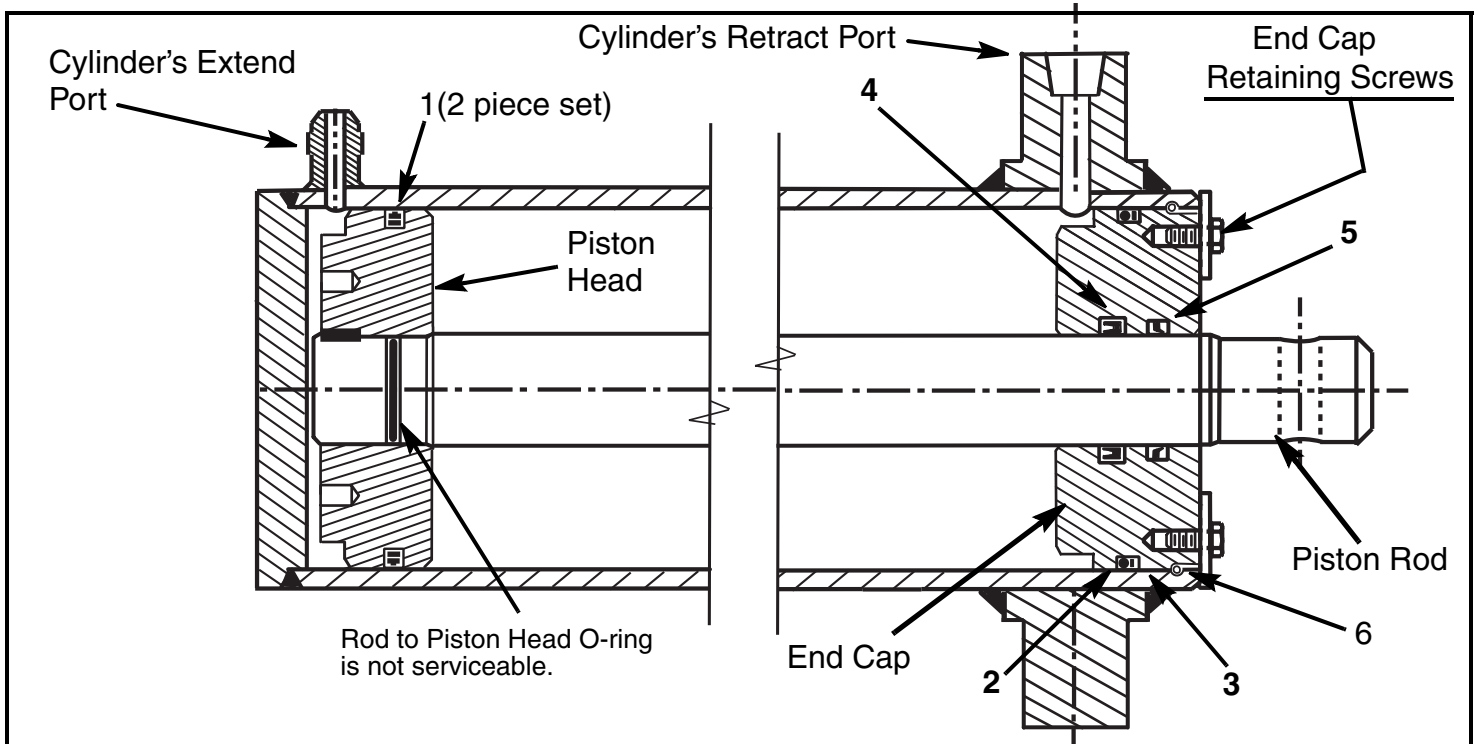

FIGURE 1

Service Kit Contents

(See Figure 1)

ITEM NO.	PART NUMBER	QTY	DESCRIPTION
1	*	1	Piston Seal: 2 piece set (Outer ring w/ flat under ring)
2	*	1	O-ring
3	*	1	Backup Ring
4	*	1	Rod-Guide U-Cup
5	*	1	Scraper: Rod
6	*	1	Ring: Retaining
7	*	1	THIS INSTRUCTION SHEET

* - Not Available Separately



Hot hydraulic fluid can cause burns. Do not work on the cylinder until the hydraulic system has cooled to ambient temperature after use.



Hydraulic fluid under high pressure can be dangerous. A high-pressure hydraulic fluid leak or spray can penetrate the skin. If this happens, seek immediate medical attention to reduce the risk of blood poisoning leading to death or limb amputation.



If a piece of hydraulic equipment develops a high pressure leak, turn it off immediately. Do not operate it until the leak is repaired.

For your safety and eye protection wear safety glasses during the following repair.

IMPORTANT! - The cylinder should be disassembled in a clean environment to prevent dirt or other contamination from entering the interior of the cylinder. Prior to proceeding, clean any accumulated dirt or debris from the port openings, end cap areas and the beam around the piston rod end of the cylinder. Clean the beam's surface where the wedge sides and lubricate that surface with engine oil.

RECOMMENDED TOOLS:

Safety glasses, wheel blocks, pair of saw horses and a 4"x4" x 4' wood beam, a heavy duty ratchet tie down strap, heavy duty bench and 2 vises, a flat soft metal or wood dowel punch, hammer, SAE and metric wrenches and sockets w/ ratchet, 1/2" diameter x 12-15" long steel rod, 5 ft. of 3/4" clear plastic tubing, 2 flat blade screw drivers (one thin blade and one large blade, 5 gal. clean plastic bucket, a clean oil pan, clean hydraulic oil, and clean paper or shop towels.

Pre-Service Preparation:

1. Place the log splitter on a flat and level surface.
2. Block the wheels at the front and rear to prevent the log splitter from rolling during cylinder removal. Position the beam in the horizontal position and secure with the horizontal beam lock.
3. If the piston rod is fully extended, proceed to Step 4.

If the piston rod is somewhere other than fully extended and the log splitter is **SAFE** to operate (see both "**DANGER**" notes above), start the engine and extend the piston rod to the fully extended position. Turn off the engine. Proceed to Step 4.

If the piston rod is somewhere other than fully extended but is **NOT SAFE** to operate (see both "**DANGER**" notes above), proceed to Step 4.

4. Cycle the control valve lever between the RETRACT and EXTEND positions to dump any residual pressure in the cylinder and hoses.
5. Allow engine, muffler and hydraulic cylinder to cool before proceeding.
6. Remove the spark plug wire from the spark plug and ground wire to the engine block.

Draining the Cylinder:

7. Using an adjustable wrench, remove the J.I.C. flare nut from the cylinder's EXTEND port. Cap the end of the 1/2" hydraulic tube with a 3/4"-16 J.I.C. (37⁰ Flare) male plug or plastic cap or plug. Leave the EXTEND port fitting open.

NOTE: *In the next step the return-to-tank hose will be removed from the filter adapter fitting. There is hydraulic fluid in the hose and control valve. Have a oil drain pan ready to collect the fluid.*

8. Place an oil drain pan below the return-to-tank hose connection at the filter adapter. Loosen and remove the hose clamp and remove the return-to-tank hose from the filter adapter fitting, place the hose end into the oil drain pan to drain. Then place the end of the return-to-tank hose into the 5 gal. bucket. See Figure 2.

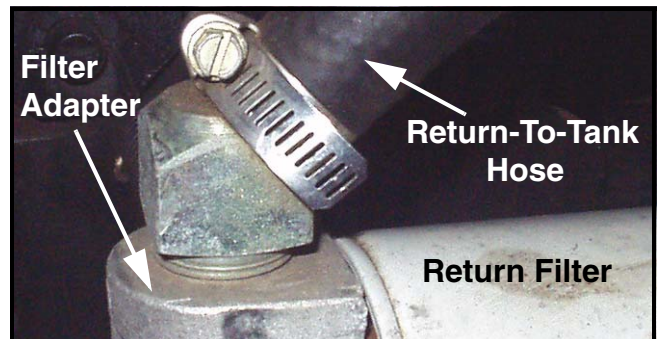

FIGURE 2

9. If the piston rod is in the **fully extended** position proceed to Step 13.

If the piston rod is **fully retracted** or **somewhere between fully retracted and fully extended**, perform Steps 10 and 12 and then perform Steps 13 through 19.

Draining the RETRACT Side of Cylinder...

10. Place and temporarily restrain the control valve lever in the EXTEND position. Optional method, see Figure 3.

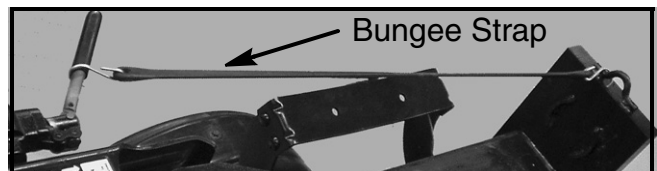

FIGURE 3

11. Using a heavy duty ratchet strap around the back of the wedge and the beam's foot plate, SLOWLY pull (extend) the piston rod out to expel the fluid from the cylinder into the 5 gal. bucket.

12. After draining has stopped, remove the return-to-tank hose from the 5 gal. bucket.

Draining the EXTEND Side of Cylinder...

13. Install the 3/4" ID clear plastic tubing onto the cylinder's extend port fitting and secure with the hose clamp removed in Step 10. Place the end of the tubing into the 5 gal. bucket.

14. Place and temporarily restrain the control valve lever in the EXTEND position.

15. Using a 3/4" socket and ratchet and a 3/4" box wrench, remove and retain the 1/2"-13 lock nut and 1/2" cross bolt securing the wedge to the piston rod.

16. Slide the wedge away from the cylinder until it is against the foot plate.

17. Place the 1/2" diameter steel rod through the hole in the end of the piston rod. Using a heavy duty ratchet strap around wrapped around the steel rod and the back end of the cylinder, SLOWLY pull (retract) the piston rod to expel the fluid from the cylinder into the 5 gal. bucket.

18. Remove the clear plastic hose from the extend port fitting.

19. Loosen the hose clamp at the control valve fitting and remove the return-to-tank hose from the fitting.

Proceed to "Cylinder w/ Control Valve Assembly Removal"

Cylinder w/ Control Valve Assembly Removal:

20. Support the back end of the cylinder about 5" from the end of the cylinder to keep the cylinder from tipping off the beam when the dislodger is removed in Step 22. Suggested support: Using a pair of saw horses, place one saw horse on either side at the rear of the cylinder. Place a 4" x 4" or two 2"x4"x 4' (screwed together) wood beam across the saw horses. See Figure 4.

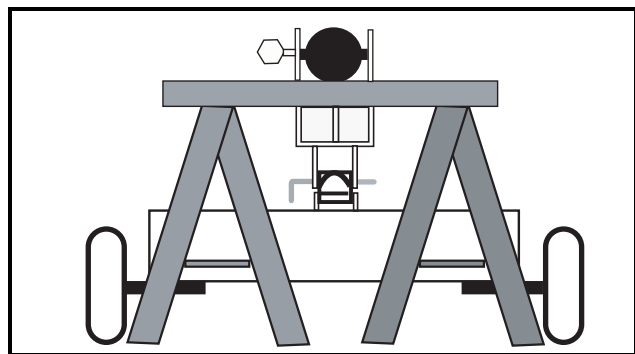

FIGURE 4

21. Place an oil pan under the pump. Remove the high pressure (pump output) hose from the pump and drain the hose into to pan. Cap the end of the pump output fitting and end fitting of the high pressure hose.

22. Using a 9/16" socket and ratchet, remove and retain the six 3/8"-16 x 1.0 self-tapping screws securing the dislodger to the beam bracket. Remove the dislodger.

23. **CAUTION** - The cylinder w/control valve assembly is very heavy and requires two strong individuals to lift the assembly from the beam and place it in a vise. Remove cylinder assembly from the beam and secure in a bench vise.

NOTE: *DO NOT over tighten* the vise jaws which can deform the cylinder. Excess vise pressure will not allow piston rod removal from the cylinder.

Piston Rod Assembly Removal:

NOTE: *There will be some oil remaining in the cylinder. Place sufficient paper towels or shop towels under the piston rod end of the cylinder to absorb the residual oil when the end cap is removed.*

24. Remove the two (2) end cap retaining cap screws and flat washers that are installed on the face of the end cap. See Figure 1.

25. Using a flat punch (aluminum, brass or wood dowel), gently tap on the end of the punch with a hammer to drive the end cap back into the cylinder bore until the face of the end cap is past the retaining ring. Alternate sides when tapping on the end cap to drive the end cap back evenly. See Figure 5.

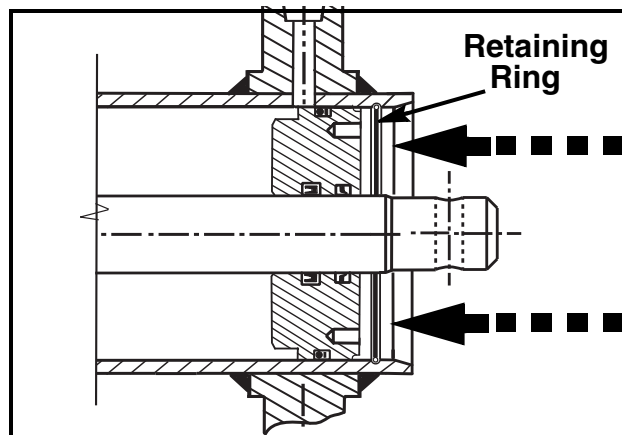

FIGURE 5

26. Using your fingers, remove the retaining ring from the groove in the cylinder wall.

NOTE: *A screw driver may also be used to lift the retaining ring out of the groove. Be very careful not to scratch any part of the cylinder bore which may damage the piston seals upon reassembly.*

IMPORTANT - In the next step be careful when removing the piston assembly (piston rod and head) and end cap as they may separate from the cylinder barrel quickly. Be ready to support the weight of the assembly. Be careful not to mar the chromed surface of the piston rod.

NOTE: The piston head seal and end cap static seal will likely be cut by the edge of the retaining ring groove on removal from the barrel. This result is normal and difficult to avoid.

27. While keeping the piston rod centered and parallel with the cylinder, pull the piston rod out vigorously and allow the piston head to bump the end cap. Continue to pull the end cap with piston assembly out of the cylinder bore.

28. Secure the piston rod so that the end cap can be removed. If securing the piston rod in a vise, use clean cardboard or a thick dense rubber sheet to pad the vise jaws.

BE CAREFUL not to scratch or mar the piston rod chromed surface, it cannot be repaired if dented or scratched.

29. Remove the end cap from the piston rod by pulling it off the end of the piston rod.

Seal Replacement Instructions:

IMPORTANT - Make note (sketch) the position and orientation of the seals on the piston head and end cap before removing them to assist in replacement. It is very important that the two small seals are set into their respective grooves in the same orientation as the old seals are.

30. The seals may be removed with a sharp tool like an awl (brass awls are preferred) by carefully pushing the point partially into the seal and prying the seal from the groove. Hard seals can be removed by carefully cutting the seal with an exacto type blade being careful not to scratch the groove walls or adjacent surfaces. Discard the old seals.

31. Inspect the seal grooves and clean away any contamination. Apply a light coating of clean oil to the new seals and into the seal grooves to ease installation and prevent scuffing of the sealing surfaces.

Optional - A plain petroleum jelly may be used in lieu of or in combination with the clean oil.

32. Install the new seals into the appropriate seal grooves on the piston head and in and on the end cap.

33. Coat the internal end cap seals and chromed end of the piston rod with additional oil and/or petroleum jelly.

34. Carefully assemble the end cap onto the piston rod by gently pushing it over the end of the piston rod.

35. Apply a light coating of clean oil to the piston head and end cap outer diameters, and to the mouth of the cylinder barrel.

36. Carefully position the piston head so that it is centered and square with the cylinder wall mouth.

37. Once started, push firmly until the piston is about half way down the length of the cylinder bore.

NOTE: Be careful not to mar the chromed piston rod surface in the next step.

38. Carefully push the end cap into the cylinder bore until the front face is past the retaining ring groove. The end cap may have to be gently driven down into the cylinder bore using a hammer and a soft metal or wood dowel.

39. Install the end-cap Retaining Ring, Item 6, into the cylinder's groove. Ensure that the ring is completely nested into the bottom of the groove.

40. Pull the piston rod outward until the piston head contacts the end cap. Continue to pull on the piston rod until the end cap is firmly in position against the retaining ring.

41. Install the end cap retaining cap screws and washers.

42. Push the piston rod in until the piston bottoms in the cylinder. (Full retracted position)

NOTE: Check the cylinder's EXTEND port fitting and the hydraulic tube's flare nut to ensure that there are no nicks, scratches or debris on the fitting's coned/tapered surfaces that can cause leaks under pressure.

43. Reconnect the 1/2" hydraulic tube, removed in Step 7, to the cylinder's EXTEND port fitting. Tighten securely.

Cylinder Assembly to Beam Reassembly:

44. Carefully install the cylinder w/ control valve assembly back onto the log splitter beam's cylinder trunnions sockets ensuring that the rear of the cylinder is supported by the saw horses.

45. Re-attach the splitting wedge to the piston rod using the hardware removed in Step 16. Do not tighten hardware, nut should be threaded on until it is approximately 1/16" from wedge surface. Bolt should float freely.

46. Re-install the dislodger and hardware removed in Step 22. Tighten hardware securely.

47. Reconnect the high pressure hose to the pump's output port fitting. Ensure the hose is routed between the beam and the tongue.

48. Reconnect the return-to-tank hose to the filter adapter fitting and the control valve fitting. Tighten the hose clamps to 50-60 In.-Lbs.

49. Ensure that the wedge's path is clean of debris and the beam surface is well lubricated with engine oil during the following cycling.

Refilling and Purging the Cylinder:

50. Check the level of the hydraulic oil in the tank. If low add the appropriate hydraulic oil (see the Operator's Manual) to bring the level up into the fill/full marks on the dipstick. Replace the dipstick securely when full.

51. Remove any restraining device from the lever of the control valve. Ensure the control valve lever is in the NEUTRAL position.

52. Reconnect the spark plug wire to the spark plug. Start the log splitter engine.

53. Move the control valve lever to the EXTEND position. Allow the cylinder piston rod to fully extend until it stops. Allow pressure to set there for about 5 seconds. Check for fluid leaks around the cylinder's EXTEND port fitting.

54. Move the control valve lever to the RETRACT position. Allow the cylinder piston rod to fully retract into the cylinder. The control lever will return to neutral automatically at the end of the retract stroke. Check for fluid leaks around the piston rod and end cap.

55. Check the level of the hydraulic oil in the tank. If low add the appropriate hydraulic oil (see the Operator's Manual) to bring the level up into the fill/full marks on the dipstick. Replace the dipstick securely when full.

56. Repeat the full EXTEND and RETRACT cycle sequence at least an additional ten (10) times to purge the system of air.

NOTE: *Air remaining in the hydraulic lines and/or cylinder will cause an erratic stroke and or slow response. Additional cycling will be needed to remove the air from the system.*

57. Ensure that the control valve lever when in the RETRACT position automatically kicks off (to NEUTRAL) effectively and consistently at the end of the retract stroke.

58. Check for leaks. If no leaks are found, remove any blocking.

This completes the installation of the hydraulic seal kit.