

24A-424B711 Chipper Shredder (2008)
General Assembly

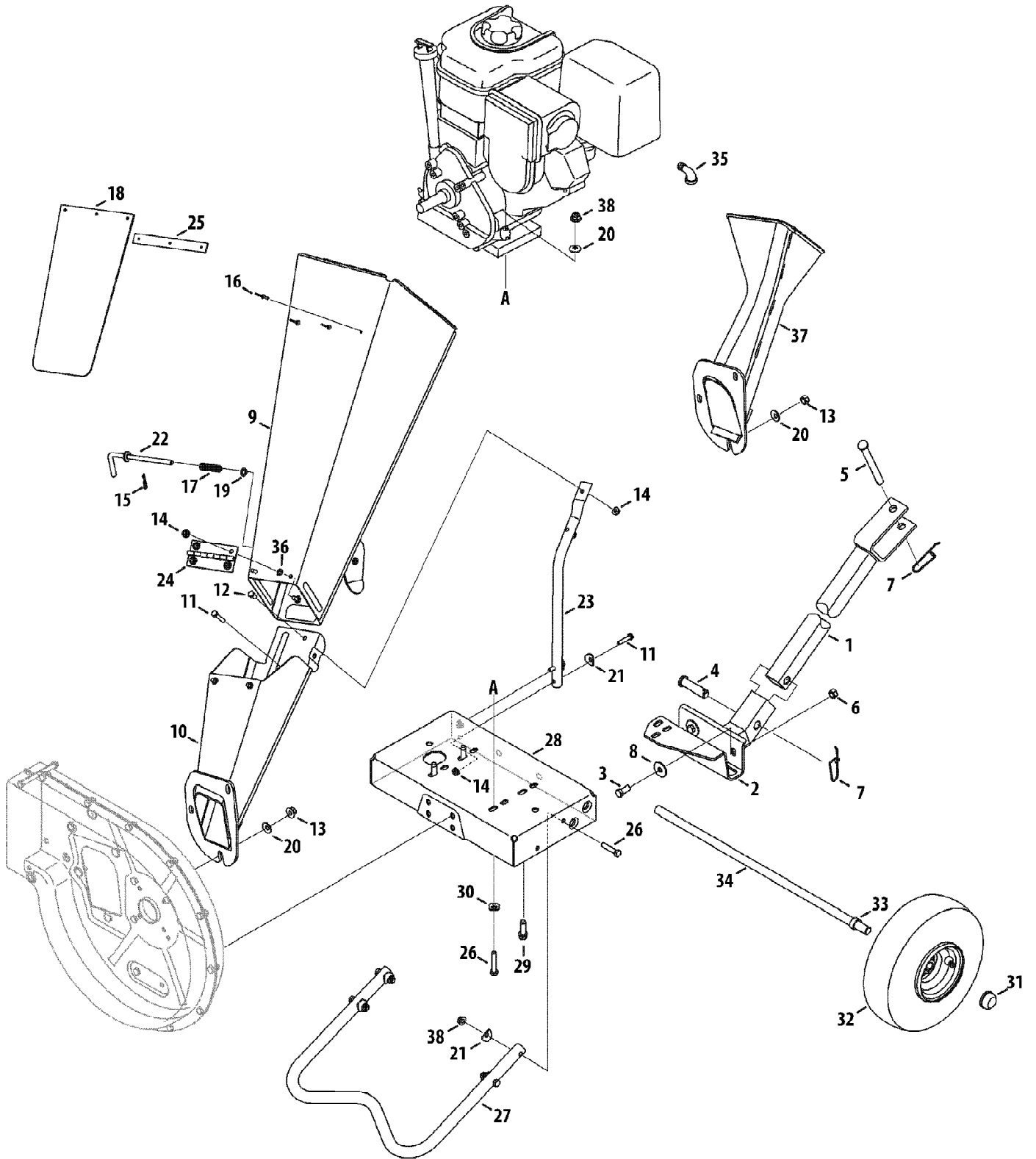

Ref #	Part Number	Qty	S/P/F	Description
1	681-0133	1		Tongue Hitch Mount
2	681-0134A	1	S	Base Hitch Mount
3	710-3001	1	/P	Hex Cap Screw, 3/8-16 x.88
4	711-0299	1	/P	Clevis Pin,.625 x 2.4
5	711-0835	1	S	Clevis Pin,.50 x 4.62
6	712-04065	1	/P	Flange Lock Nut, 3/8-16
7	732-0194	1		Spring Pin
8	736-0133	1	S	Flat Washer,.411 x 1.25 x 1.0
9	681-04006	1		Upper Chipper Chute Assembly Model Series 420
10	681-04007	1		Lower Chipper Chute Assembly Model Series 420
11	710-0106	1	/P	Hex Cap Screw, 1/4-20 x 1.25 Model Series 420
12	710-3013	1	/P	Screw, 1/4-20 x .50 Model Series 420
13	712-3010	1	S	Hex Nut, 5/16-18
14	712-04064	1	/P	Flange Lock Nut 1/4-20 Model Series 420
15	714-0104	1	S	Cotter Pin Model Series 420
16	728-0175	1		Pop Rivet Model Series 420
17	732-0306A	1	S	Compression Spring,.531 x 1.75 Model Series 420
18	735-0249A	1	/P	Chute Flap Model Series 420
19	736-0140	1	S	Flat Washer Model Series 420
20	736-0242	1	/P	Bell Washer.340 ID x.872 OD
21	736-0451	1	S	Washer,.320 ID x.93 OD
22	747-04163	1	S	Lock Rod Model Series 420
23	749-1004	1		Chipper Chute Support Model Series 420
24	781-04032	1	S	Chipper Chute Hinge Model Series 420
25	781-0633	1		Chute Flap Strip Model Series 420
26	710-0805	1	/P	Hex Cap Screw, 5/16-18 x 1.50
27	749-04104	1	S	Tube Support
28	681-0184A	1	/P	Frame Assembly Model Series 410
28	681-0183A	1		Frame Assembly Model Series 420
29	710-0502A	1	/P	Hex Sems Screw, 3/8-16 x 1.25
30	736-0170	1	S	Special Lock Washer, 5/16
31	726-0214	1	/P	Push Cap, 5/8
32	634-04009	1	S	Wheel, 10 x 4 x 4
33	750-0786	1	S	Spacer, .64 x .88 x .38
34	738-0813	1		Axle, 22.47"
35	737-0195	1	S	Elbow Fitting
36	726-0233	1	/P	Push Nut,.25ID x.50OD Model Series 420
37	681-0095	1		Chipper Chute Model Series 410
38	712-04063	1	/P	Flange Lock Nut, 5/16-18
	664-04023	1	S	Debris Collection Bag Not Shown
	723-0400	1	/P	Safety Glasses Not Shown

24A-424B711 Chipper Shredder (2008)
Impeller Assembly

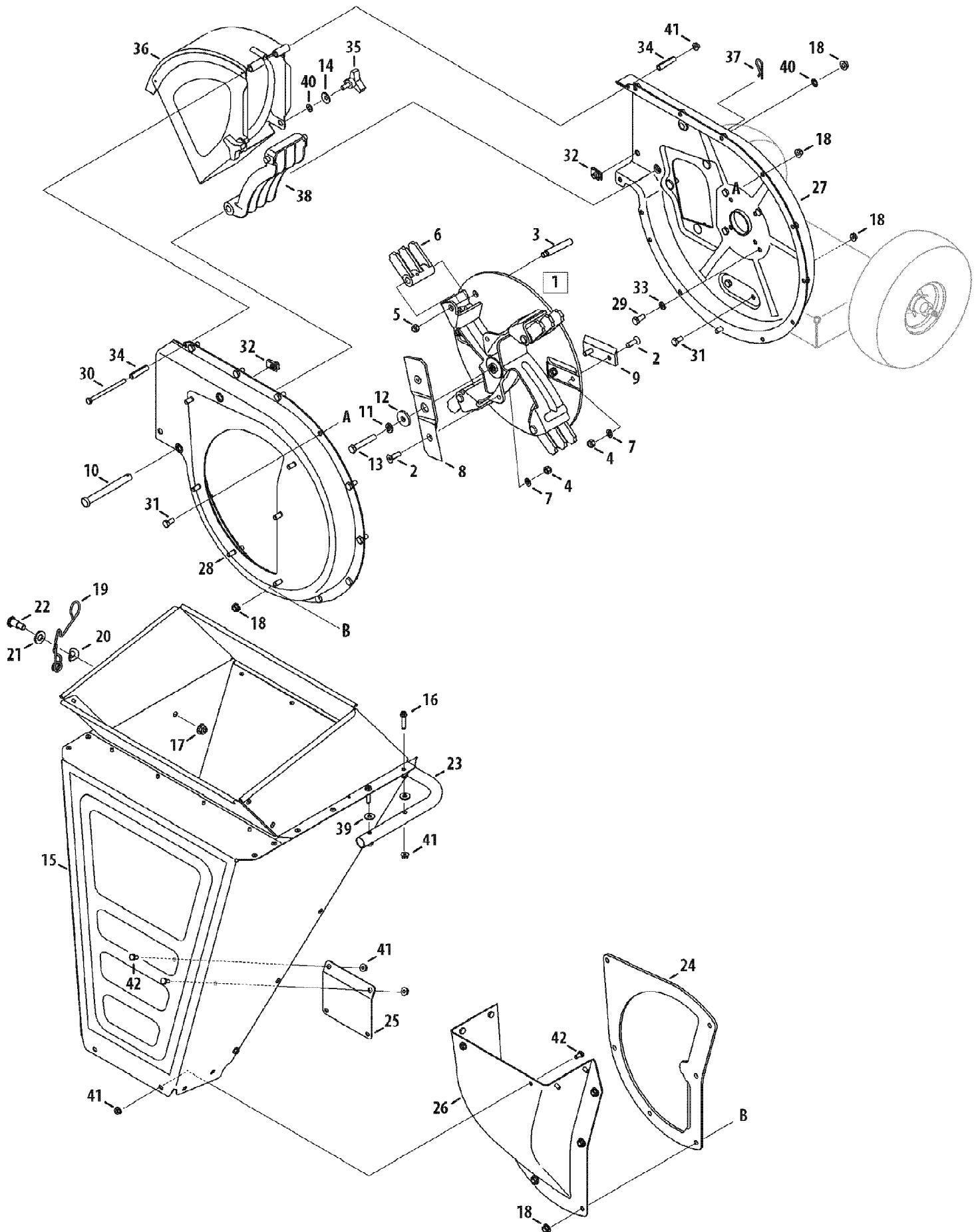

24A-424B711 Chipper Shredder (2008)
Impeller Assembly

Page 4 of 8

Ref #	Part Number	Qty	S/P/F	Description
1	681-04094	1	S	Impeller Assembly Complete
2	710-1054	1	/P	Machine Screw, 5/16-24 x 1.0
3	738-04286	1	S	Shoulder Pin, .5 x 2.625
4	712-0411	1	S	Hex Lock Nut, 5/16-24
5	712-0266A	1	/P	Nut, Jam Lock, 3/8-16
6	719-04308	1		Flail Blade
7	736-0119	1	S	Lock Washer, 5/16
8	742-04050	1	S	Shredder Blade
9	742-0544	1	S	Chipper Blade
10	711-0835	1	S	Clevis Pin,.50 x 4.62
11	736-0217	1	S	Lock Washer, 3/8
12	736-0247	1	/P	Flat Washer,.406 x 1.25
13	710-1254	1	/P	Hex Cap Screw, 3/8-24 x 2.2
14	736-0242	1	/P	Bell Washer.340 ID x.872 OD
15	681-04011	1		Shredder Hopper Assembly
16	710-0809	1		Hex Cap Screw, 1/4-20 x 1.250
17	712-04065	1	/P	Flange Lock Nut, 3/8-16 Model Series 420
18	712-04063	1	/P	Flange Lock Nut, 5/16-18
19	732-04167	1	S	Torsion Spring Model Series 420
20	736-0182	1	/P	Spring Washer,.50 x 1.0 x.022 Model Series 420
21	736-0326	1	S	Flat Washer,.50 x 1.0 x.0125 Model Series 420
22	738-0430	1		Shoulder Screw, 3/8-16,.50 x.685 Model Series 420
23	749-04103	1	S	Hopper Handle
24	781-04007	1		Shredder Plate
25	781-04027	1		Hopper Support Bracket
26	781-04033	1		Inlet Guide
27	681-0117	1		Inner Flail Housing Assembly
28	681-04002	1		Outer Flail Housing Assembly
29	710-0157	1	/P	Hex Cap Screw, 5/16-24 x.75
30	710-0825	1	/P	Hex Cap Screw, 1/4-20 x 3.75
31	710-3025	1	/P	Hex Cap Screw, 5/16-18 x.625
32	726-0211	1	S	U-Nut, 5/16-18
33	736-0119	1	S	Lock Washer, 5/16
34	750-0793	1	S	Hinge Spacer,.265 x.380 x 1.66
35	681-0048	1	S	Knob Ass'y. (Incl. ref.# 14 & 40)
35	720-0170	1	/P	Knob Only, 5/16-18
36	681-0094	1		Chute Deflector Assembly
37	714-0149B	1	S	Internal Cotter Pin
38	719-04070	1		Shredder Screen
39	736-0173	1	/P	Flat Washer,.28 x.74 x.063
40	726-0201	1		Speed Nut,.3125ID
41	712-04064	1	/P	Nut, Flange, Lock, 5/16-18
42	710-0599	1	/P	TT Screw, 1/4-20 x.5

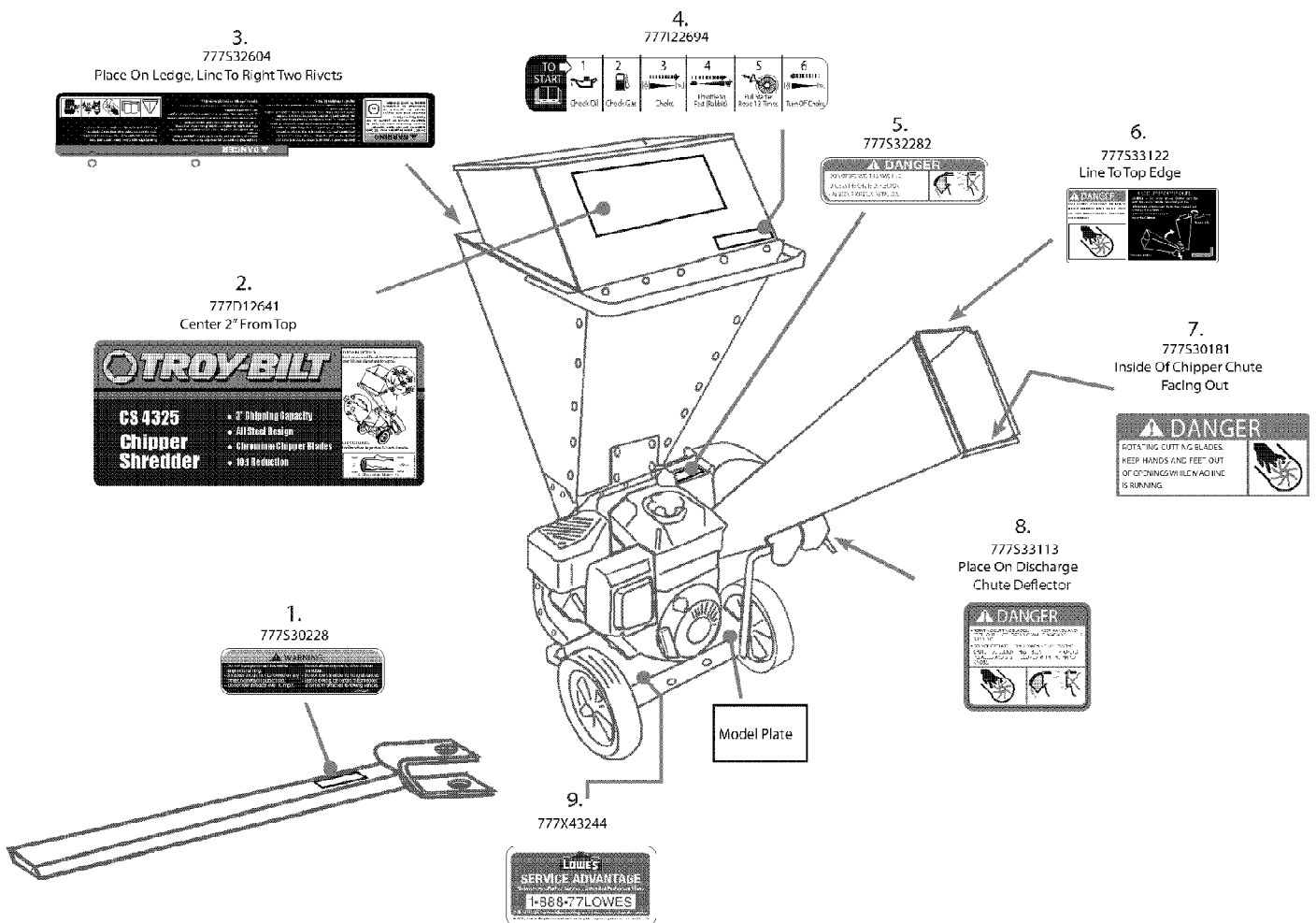

24A-424B711 Chipper Shredder (2008)
Label Map CS4325

Page 6 of 8

Ref #	Part Number	Qty	S/P/F	Description
1	777S30228	1		LABEL-TOW BAR
2	777D12641	1		LABEL-FRONT CS 4325/TROY
3	777S32604	1		LABEL-VERT/CS:HOPPER
4	777I22694	1		LABEL-START INSTRUCT
5	777S32282	1		LABEL-CHUTE
6	777S33122	1		LABEL-CHIPPER/SHREDDER DANGER
7	777S30181	1	/P	LABEL-TOP CHUTE DANGER
8	777S33113	1		LABEL-CHIPPER SHREDDER CHUTE
9	N/A	1		LABEL-LOWES:SERVICELBL

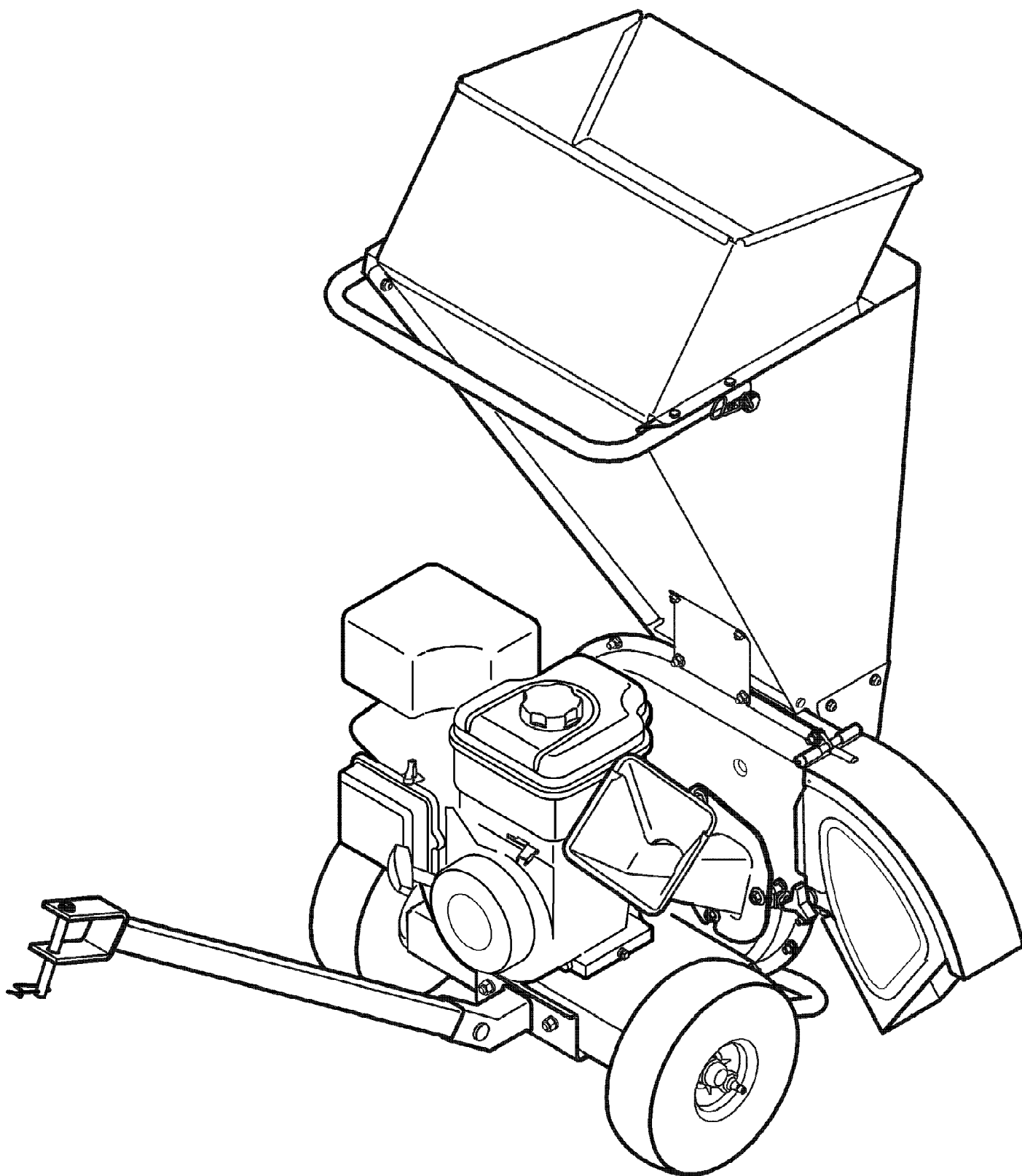

24A-424B711 Chipper Shredder (2008)
Quick Reference

Page 8 of 8

Ref #	Part Number	Qty	S/P/F	Description
	759-3336	1	/P	Spark Plug
	BS-493537S	1	/P	Pre Filter
	BS-491588S	1	/P	Air Filter - Flat
	BS-697029	1	/P	Air Filter - Oval
	N/A	1		Fuel Filter
	681-04094	1	S	Impeller Assembly
	742-0544	1	S	Chipper Blade
	742-04050	1	S	Shredder Blade
	719-04308	1		Flail Blade
	719-04070	1		Shredder Screen
	634-04009	1	S	Wheels
	726-0214	1	/P	Push Cap (Wheels)
	720-0170	1	/P	Knob
	664-04023	1	S	Bag