

MODEL NO. 8-20253

20" MOWER ILLUSTRATION

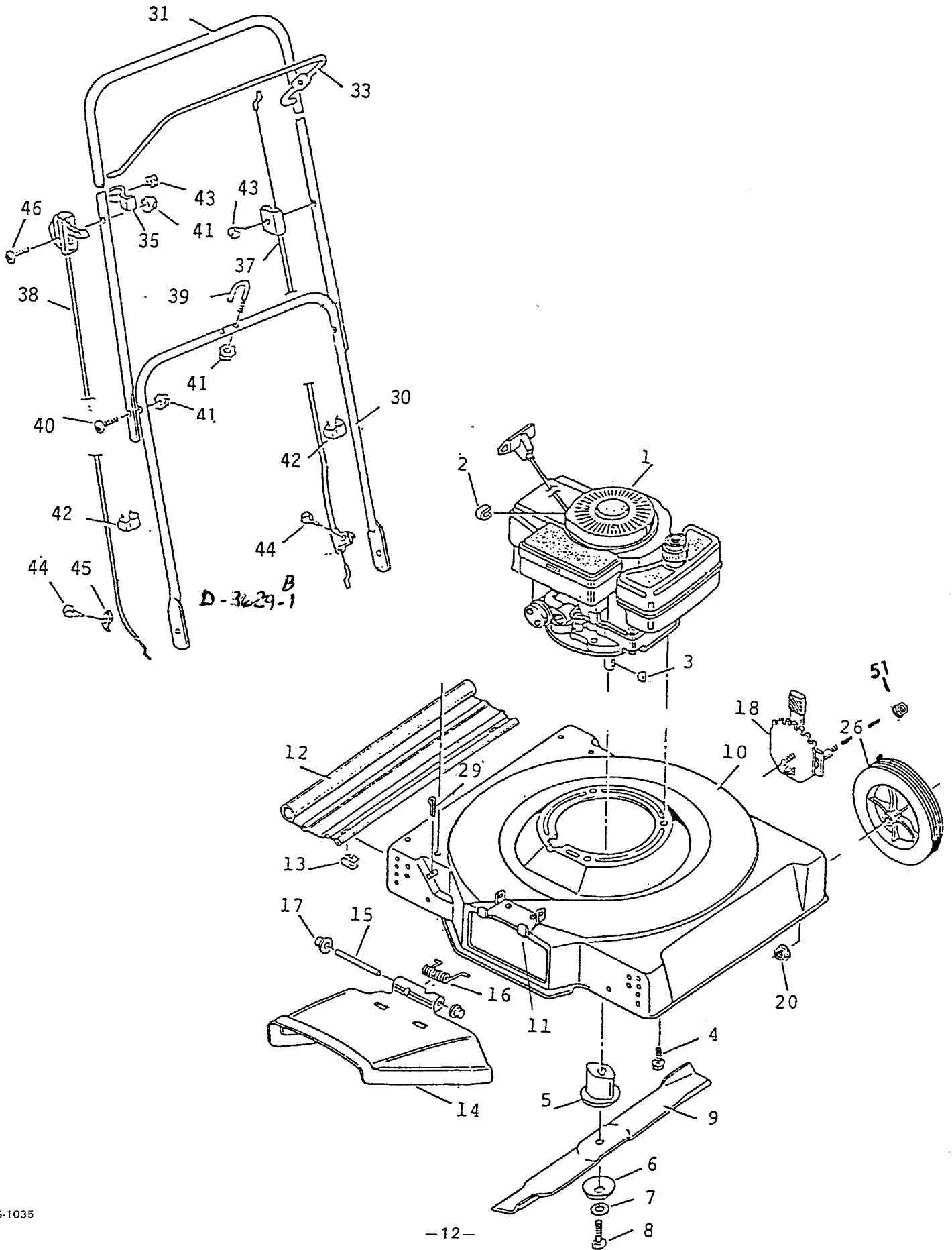

20" MOWER PARTS LIST**MODEL NO. 8-20253**

KEY NO.	DESCRIPTION	PART NO.
1	Engine*	----
2	Stop, Rope	42189
3	Key, Woodruff	20062
4	Bolt, Engine	25X6
5	Adapter, Blade	42734
6	Washer Blade	17X137
7	Washer	17X124
8	Bolt, Hex.	1X68
9	Blade	20045HT
10	Housing**	70100
11	Chute Bracket**	22271Z
12	Deflector Rear**	42746
13	Retainer**	42743
14	Deflector Chute**	42919
15	Pivot Pin**	215X11Z
16	Spring**	166X5
17	Push On Cap**	28X42
18	Height Adjuster***	----
20	Locknut Flange	15X68Z
26	Wheel And Tire	20270
29	Cotter Pin	30X35
30	Handle, Lower	43270C
31	Handle, Upper	43300C
33	Engine Stop Lever	42763C
35	Stop, Lever	43044Z
37	Engine Stop Cable	43360
38	Throttle Control	43365
39	"U" Bolt	42896Z
40	Bolt	3X136Z
41	Locknut	15X66
42	Clamp, Cable	42950
43	Screw	26X220
44	Screw	6X94
45	Clamp, Throttle Control	43093
46	Bolt	3X105
51	Nut	15X84
	Parts Bag	43421
	Instruction Book	F-88401
	Decal, Front 2X7	43X416
	Decal, R.H. Side 4X4	59X615

**NOTE: These parts are included with the blade housing assembly.

***NOTE: See the height adjuster Parts List Page.