

For Kawasaki Discount Parts Call 606-678-9623 or 606-561-4983

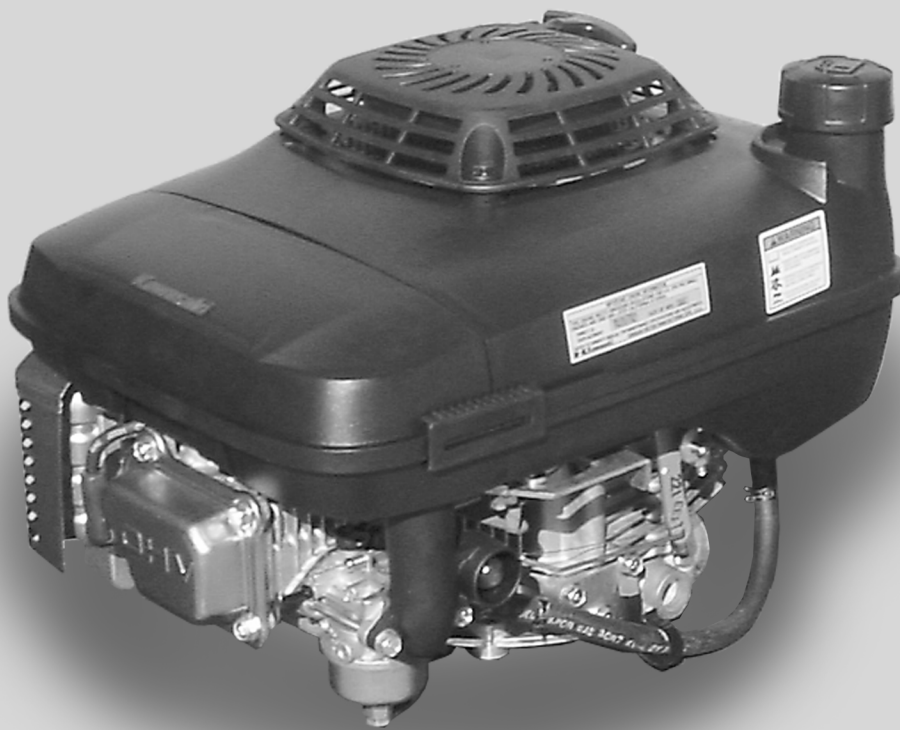

Kawasaki

FJ180V



4-stroke air-cooled gasoline engine

Service Manual

www.mymowerparts.com

For Kawasaki Discount Parts Call 606-678-9623 or 606-561-4983

www.mymowerparts.com

Quick Reference Guide

General Information	1
Periodic Maintenance	2
Fuel System	3
Cooling System	4
Engine Top End	5
Lubrication System	6
Camshaft/Crankshaft	7
Electrical System	8
Troubleshooting	9

This quick reference guide will assist you in locating a desired topic or procedure.

- Bend the pages back to match the black tab of the desired chapter number with the black tab on the edge at each table of contents page.
- Refer to the sectional table of contents for the exact pages to locate the specific topic required.

For Kawasaki Discount Parts Call 606-678-9623 or 606-561-4983

www.mymowerparts.com



FJ180V

4-stroke air-cooled gasoline engine

Service Manual

All rights reserved. No parts of this publication may be reproduced, stored in a retrieval system, or transmitted in any form or by any means, electronic mechanical photocopying, recording or otherwise, without the prior written permission of Quality Assurance Department/Consumer Products & Machinery Company/Kawasaki Heavy Industries, Ltd., Japan.

No liability can be accepted for any inaccuracies or omissions in this publication, although every possible care has been taken to make it as complete and accurate as possible.

The right is reserved to make changes at any time without prior notice and without incurring an obligation to make such changes to products manufactured previously.

All information contained in this publication is based on the latest product information available at the time of publication. Illustrations and photographs in this publication are intended for reference use only and may not depict actual model component parts.

LIST OF ABBREVIATIONS

A	ampere(s)	lb	pound(s)
ABDC	after bottom dead center	m	meter(s)
AC	alternating current	min	minute(s)
ATDC	after top dead center	N	newton(s)
BBDC	before bottom dead center	Pa	pascal(s)
BDC	bottom dead center	PS	horsepower
BTDC	before top dead center	psi	pound(s) per square inch
°C	degree(s) Celsius	r	revolution
DC	direct current	rpm	revolution(s) per minute
F	farad(s)	TDC	top dead center
°F	degree(s) Fahrenheit	TIR	total indicator reading
ft	foot, feet	V	volt(s)
g	gram(s)	W	watt(s)
h	hour(s)	Ω	ohm(s)
L	liter(s)		

Read OWNER'S MANUAL before operating.

EMISSION CONTROL INFORMATION

To protect the environment in which we all live, Kawasaki has incorporated crankcase emission (1) and exhaust emission (2) control systems (EM) in compliance with applicable regulations of the United States Environmental Protection Agency and California Air Resources Board.

1. Crankcase Emission Control System

A sealed-type crankcase emission control system is used to eliminate blow-by gases. The blow-by gases are led to the breather chamber through the crankcase. Then, it is led to the air cleaner.

Oil is separated from the gases while passing through the inside of the breather chamber from the crankcase, and then returned back to the bottom of crankcase.

2. Exhaust Emission Control System

The exhaust emission control system applied to this engine consists of a carburetor and an ignition system having optimum ignition timing characteristics.

The carburetor has been calibrated to provide lean air/fuel mixture characteristics and optimum fuel economy with a suitable air cleaner and exhaust system.

TAMPERING WITH EMISSION CONTROL SYSTEM PROHIBITED

Federal law and California State law prohibits the following acts or the causing thereof: (1) the removal or rendering inoperative by any person other than for purposes of maintenance, repair, or replacement, of any device or element of design incorporated into any new engine for the purpose of emission control prior to its sale or delivery to the ultimate purchaser or while it is in use, or (2) the use of the engine after such device or element of design has been removed or rendered inoperative by any person.

Among those acts presumed to constitute tampering are the acts listed below:
Do not tamper with the original emission related part:

- Carburetor and internal parts
- Spark plug
- Magneto or electronic ignition system
- Fuel filter element
- Air cleaner elements
- Crankcase
- Cylinder head
- Breather chamber and internal parts
- Intake pipe and tube

Foreword

This manual is designed primarily for use by trained mechanics in a properly equipped shop. However, it contains enough detail and basic information to make it useful to the owner who desires to perform his own basic maintenance and repair work. A basic knowledge of mechanics, the proper use of tools, and workshop procedures must be understood in order to carry out maintenance and repair satisfactorily. Whenever the owner has insufficient experience or doubts as to his ability to do the work, all adjustments, maintenance, and repair should be carried out only by qualified mechanics.

In order to perform the work efficiently and to avoid costly mistakes, read the text, thoroughly familiarize yourself with the procedures before starting work, and then do the work carefully in a clean area. Whenever special tools or equipment are specified, do not use makeshift tools or equipment. Precision measurements can only be made if the proper instruments are used, and the use of substitute tools may adversely affect safe operation.

To get the longest life out of your engine:

- Follow the Periodic Maintenance Chart in the Service Manual.
- Be alert for problems and non-scheduled maintenance.
- Use proper tools and genuine Kawasaki engine parts. Genuine parts provided as spare parts are listed in the Parts Catalog.
- Follow the procedures in this manual carefully. Don't take shortcuts.
- Remember to keep complete records of maintenance and repair with dates and any new parts installed.

How to Use This Manual

In this manual, the product is divided into its major systems and these systems make up the manual's chapters. The Quick Reference Guide shows you all of the product's system and assists in locating their chapters. Each chapter in turn has its own comprehensive Table of Contents.

For example, if you want ignition coil information, use the Quick Reference Guide to locate

the Electrical System chapter. Then, use the Table of Contents on the first page of the chapter to find the Ignition coil section.

Whenever you see these WARNING and CAUTION symbols, heed their instructions! Always follow safe operating and maintenance practices.

WARNING

This warning symbol identifies special instructions or procedures which, if not correctly followed, could result in personal injury, or loss of life.

CAUTION

This caution symbol identifies special instructions or procedures which, if not strictly observed, could result in damage to or destruction of equipment.

This manual contains four more symbols (in addition to WARNING and CAUTION) which will help you distinguish different types of information.

NOTE

○ *This note symbol indicates points of particular interest for more efficient and convenient operation.*

- Indicates a procedural step or work to be done.
- Indicates a procedural sub-step or how to do the work of the procedural step it follows. It also precedes the text of a WARNING, CAUTION, or NOTE.
- ★ Indicates a conditional step or what action to take based on the results of the test or inspection in the procedural step or sub-step it follows.

In most chapters an exploded view illustration of the system components follows the Table of Contents. In these illustrations you will find the instructions indicating which parts require specified tightening torque, oil, grease or a locking agent during assembly.

General Information

TABLE OF CONTENTS

Before Servicing	1- 2
Model Identification.....	1- 4
General Specifications.....	1- 5
Torque and Locking Agent.....	1- 6

1-2 GENERAL INFORMATION

Before Servicing

Before starting to service the engine, carefully read the applicable section to eliminate unnecessary work. Photographs, diagrams, notes, cautions, warnings, and detailed descriptions have been included wherever necessary. Nevertheless, even a detailed account has limitations, a certain amount of basic knowledge is required for successful work.

Especially note the following:

(1) Dirt

Before removal and disassembly, clean the engine. Any dirt entering the engine, carburetor, or other parts, will work as an abrasive and shorten the life of engine. For the same reason, before installing a new part, clean off any dust or metal filings.

(2) Tightening Sequence

Generally, when installing a part with several bolts, nuts, or screws, start them all in their holes and tighten them to a snug fit. Then tighten them evenly, in a staggered sequence. This is to avoid distortion of the part and/or causing gas or oil leakage. Conversely when loosening the bolts, nuts, or screws, first loosen all of them by about a quarter of a turn and then remove them. Where there is a tightening sequence indication in this Service Manual, the bolts, nuts, or screws must be tightened in the order and method indicated.

(3) Torque

When torque values are given in this Service Manual, use them. Either too little or too much torque may lead to serious damage. Use a good quality, reliable torque wrench.

(4) Force

Common sense should dictate how much force is necessary in assembly and disassembly. If a part seems especially difficult to remove or install, stop and examine what may be causing the problem. Whenever tapping is necessary, tap lightly using a wooden or plastic-faced mallet. Use an impact driver for screws (particularly for the removal of screws held by a locking agent) in order to avoid damaging the heads.

(5) Edges

Watch for sharp edges, especially during major engine disassembly and assembly. Protect your hands with gloves or a piece of thick cloth when lifting the engine or turning it over.

(6) High-Flash Point Solvent

A high-flash point solvent is recommended to reduce fire danger. A commercial solvent commonly available in North America is Standard solvent (generic name). Always follow manufacturer and container directions regarding the use of any solvent.

(7) Gasket, O-Ring

Do not reuse a gasket or O-ring once it has been in service. The mating surfaces around the gasket should be free of foreign matter and perfectly smooth to avoid oil or compression leaks.

(8) Press

A part installed using a press or driver, such as a journal, should first be coated with oil on its outer or inner circumference so that it will go into place smoothly.

(9) Oil Seal and Grease Seal

Replace any oil or grease seals that were removed with new ones, as removal generally damages seals.

When pressing in a seal which has manufacturer's marks, press it in with the marks facing out. Seals should be pressed into place using a suitable driver, which contacts evenly with the side of seal, until the face of the seal is even with the end of the hole.

(10) Seal Guide

A seal guide is required for certain oil or grease seals during installation to avoid damage to the seal lips. Before a shaft passes through a seal, apply a little oil, preferably high temperature grease on the lips to reduce rubber to metal friction.

(11) Lubrication

Engine wear is generally at its maximum while the engine is warming up and before all the rubbing surfaces have an adequate lubricative film. During assembly, oil or grease (whichever is more suitable) should be applied to any rubbing surface which has lost its lubricative film. Old



Before Servicing

grease and dirty oil should be cleaned off. Deteriorated grease has lost its lubricative quality and may contain abrasive foreign particles.

Don't use just any oil or grease. Some oils and greases in particular should be used only in certain applications and may be harmful if used in an application for which they are not intended. This manual makes reference to molybdenum disulfide grease (MoS₂) in the assembly of certain engine parts. Always check manufacturer recommendations before using such special lubricants.

(12)Electrical Wires

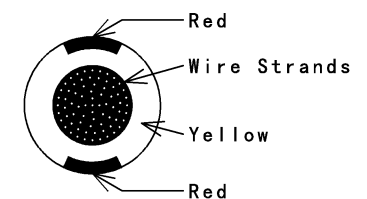
All the electrical wires are either single-color or two-color and, with only a few exceptions, must be connected to wires of the same color. On any of the two-color wires there is a greater amount of one color and a lesser amount of a second color, so a two-color wire is identified by first the primary color and then the secondary color. For example, a yellow wire with thin red stripes is referred to as a "yellow/red" wire; it would be a "red/yellow" wire if the colors were reversed to make red the main color.

Wire (cross-section)	Color Indicated on the Wire	Color Indicated on the Wiring Diagram
	Yellow/Red	

GB020601W1 C

(13)Replacement Parts

When there is a replacement instruction, replace these parts with new ones every time they are removed. These replacement parts will be damaged or lose their original function once removed.

(14)Inspection

When parts have been disassembled, visually inspect these parts for the following conditions or other damage. If there is any doubt as to the condition of them, replace them with new ones.

Abrasion	Crack	Hardening	Warp
Bent	Dent	Scratch	Wear
Color change	Deterioration	Seizure	

(15)Specifications

Specification terms are defined as follows:

"Standards" show dimensions or performances which brand-new parts or systems have.

"Service Limits" indicate the usable limits. If the measurement shows excessive wear or deteriorated performance, replace the damaged parts.

1-4 GENERAL INFORMATION

Model Identification



KB03B002 S

General Specifications

Items	FJ180V
Type of engine	Forced air-cooled, vertical shaft, OHV, 4-stroke gasoline engine
Bore x Stroke	65 mm x 54 mm (2.56 in x 2.13 in)
Piston displacement	179 mL (10.9 cu. in)
Direction of rotation	Counterclockwise facing the PTO shaft
Compression release	Automatic compression release
High idle speed	3200 rpm
Ignition system	Flywheel magneto with CDI
RFI	Per Canada and U.S.A. requirements
Starting system	Recoil starter
Spark plug	NGK BPR5ES
Carburetor	Float type, fixed main jet
Air cleaner	Dual stage element, dry type
Governor	Flyweight all speed governor
Lubrication system	Pressure feed by positive displacement pump
Oil capacity (when engine is completely dry)	0.65 L (0.69 US-qt)
Cooling system	Forced air cooling by fan
Dimensions (L x W x H)	390 mm x 307 mm x 284mm (15.4 in x 12.1 in x 11.2 in)
Dry weight	15.0 kg (33.3 lb)

Specifications subject to change without notice.

1-6 GENERAL INFORMATION

Torque and Locking Agent

The following tables list the tightening torque for the major fasteners, and the parts requiring use of a non-permanent locking agent or liquid gasket.

Letters used in the "Remarks" column mean:

L : Apply a non-permanent locking agent to the threads.

M : Apply a molybdenum disulfide lubricant (grease or oil) to the threads, seated surface, or washer.

O : Apply an oil to the threads, seated surface, or washer.

S : Tighten the fasteners following the specified sequence.

SS : Apply silicone sealant.

Fastener	Torque			Remarks
	N·m	kgf·m	ft·lb	
Fuel System:				
Throttle Valve Screw	0.7	0.07	6 in·lb	
Main Jet	1.1	0.11	9.7 in·lb	
Governor Arm Clamp Nut	7.8	0.80	69 in·lb	
Priming Nut	1.2	0.12	11 in·lb	
Fuel Tank Cover Bolts	6.9	0.70	61 in·lb	
Tank Drain Bolt	6.9	0.70	61 in·lb	
Float Chamber Mounting Bolt	5.4	0.55	48 in·lb	
Drain Screw	4.2	0.43	37 in·lb	
Cooling System:				
Flywheel Bolt	42	4.3	31	
Engine Top End:				
Cylinder Head Bolts	★22	★2.2	★16	★=S
Valve Clearance Lock Screws	6.9	0.70	61 in·lb	
Connecting Rod Big End Cap Bolts	★5.9	★0.60	★52 in·lb	★=O
Rocker Arm Bolts	28	2.8	20	
Rocker Cover Mounting Bolts	5.9	0.60	52 in·lb	
Spark Plug	22	2.2	16	
Muffler Cover Self Tap Bolt (1)	6.9	0.70	61 in·lb	
Lubrication System:				
Oil Drain Plug	22	2.2	16 in·lb	
Oil Filter Cover Bolt	6.9	0.70	61 in·lb	
Camshaft/Crankshaft:				
Crankcase Cover Bolts	★8.8	★0.90	★78 in·lb	★= S
Electrical System:				
Flywheel Bolt	42	4.3	31	
Recoil Starter Mounting Bolts	6.9	0.70	61 in·lb	
Recoil Starter Set Screw	1.0	0.10	8.9 in·lb	
Spark Plug	22	2.2	16	
Brake Lever Assembly Mounting Bolt	6.9	0.70	61 in·lb	
Kill Switch Bolt	1.5	0.15	13 in·lb	
Brake Arm Mounting Bolt	9.3	0.95	82 in·lb	

Torque and Locking Agent

The table below, relating tightening torque to thread diameter, lists the basic torque for the bolts and nuts. Use this table for only the bolts and nuts which do not require a specific torque value. All of the values are for use with dry solvent-cleaned threads.

Basic Torque for General Fasteners

Threads dia (mm)	Torque		
	N·m	kgf·m	ft·lb
4	2.0	0.20	17 in·lb
5	3.4	0.35	30 in·lb
6	5.9	0.60	52 in·lb
8	15	1.5	11

For Kawasaki Discount Parts Call 606-678-9623 or 606-561-4983

www.mymowerparts.com

Periodic Maintenance

TABLE OF CONTENTS

Periodic Maintenance Chart	2- 2
Specifications	2- 3
Special Tools	2- 4
Periodic Maintenance Procedures.....	2- 5
Fuel System.....	2- 5
High Idle Speed Adjustment	2- 5
Fuel System Cleanliness Inspection	2- 5
Fuel Filter Inspection.....	2- 6
Air Element Removal	2- 6
Air Element Installation	2- 7
Air Element Cleaning and Inspection.....	2- 7
Air Cleaner Housing (Case and Body) Inspection	2- 8
Engine Top End	2- 8
Cylinder Head Cleaning and Inspection.....	2- 8
Valve Clearance Inspection	2- 8
Valve Clearance Adjustment.....	2- 9
Valve Seat Inspection	2- 9
Valve Seat Repair	2-10
Lubrication System	2-13
Oil Level Inspection.....	2-13
Oil Change	2-13
Electrical System	2-14
Spark Plug Cleaning and Inspection.....	2-14
Spark Plug Gap Inspection	2-14

2-2 PERIODIC MAINTENANCE

Periodic Maintenance Chart

To ensure satisfactory operation over an extended period of time, any engine requires normal maintenance regular intervals. The Periodic Maintenance Chart below shows periodic inspection and maintenance items and suitable intervals. The bullet mark (●) designates that the corresponding item should be performed at that interval.

Some adjustments require the use of special tools or other equipment. An electronic tachometer will facilitate setting idle and running speeds.

OPERATION	INTERVAL						
	Daily	First 8 hr.	Every 25 hr.	Every 50 hr.	Every 100 hr.	Every 200 hr.	Every 300 hr.
Check or clean air intake screen	●						
Check and add engine oil	●						
Check for fuel and oil leakage	●						
Check for loose or lost nuts and screws	●						
Clean air cleaner foam element (1)			●				
Clean air cleaner paper element (1)				●			
Tighten nuts and screws					●		
Change engine oil		●			●		
Clean and re-gap spark plug					●		
Change air cleaner paper element (1)						●	
Clean dust and dirt from cylinder and cylinder head fins (1)							●
Check and adjust valve clearance ★							●
Clean and lap valve seating surface ★							●
Clean combustion chamber ★							●

(1): Service more frequently under dusty conditions.

★: These items must be performed with the proper tools. See your authorized Kawasaki Engine Dealer for service, unless you have the proper equipment and mechanical proficiency.

Specifications

Item	Standard
Fuel System	
High idle speed	3200 r/min (rpm)
Air cleaner:	
Type	Dual stage filtration system
Pre-cleaner	Foam element
Second-stage cleaner	Paper element
Engine Top End	
Valve clearance	Intake Exhaust 0.10 ~ 0.15 mm (0.004 ~ 0.006 in.)
Valve seating surface angle	Intake Exhaust 45°
Valve seating surface width	Intake Exhaust 0.6 ~ 0.9 mm (0.024 ~ 0.035 in.)
Lubrication System	
Engine oil:	
Type	SF, SG, SH or SJ class
Viscosity	SAE30, SAE10W-30
Capacity	[When engine is completely dry] 0.65 L (0.69 US-qt)
Level	Operating range (grid area) on dipstick
Electrical System	
Spark plug gap	0.75 mm (0.030 in.)

2-4 PERIODIC MAINTENANCE

Special Tools

Valve Seat Cutter, 45° - ϕ 27.5: 57001-1114

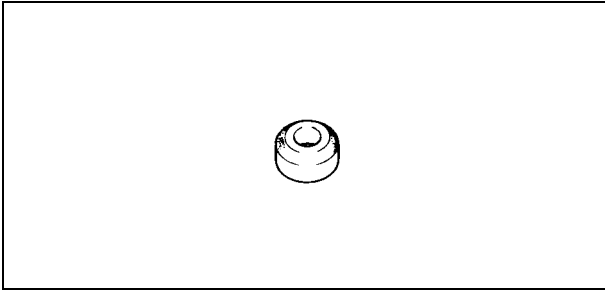

Valve Seat Cutter Holder Bar: 57001-1128

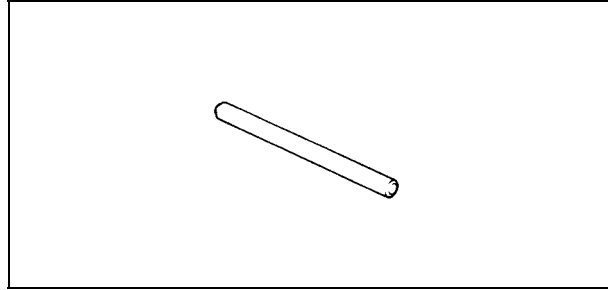

Valve Seat Cutter, 32° - ϕ 25.0: 57001-1118

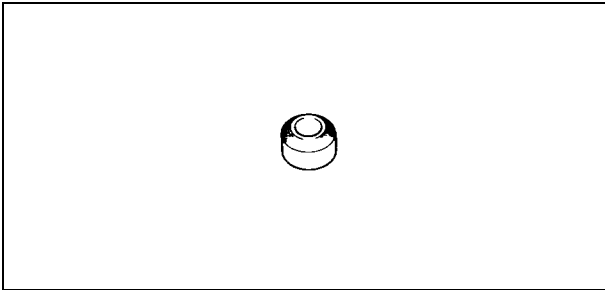

Valve Seat Cutter Holder - ϕ 6.0: 57001-1360

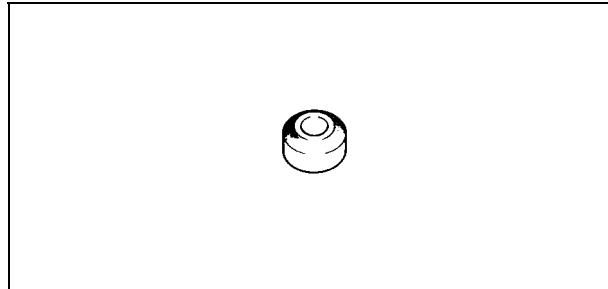

Valve Seat Cutter, 32° - ϕ 28.0: 57001-1119

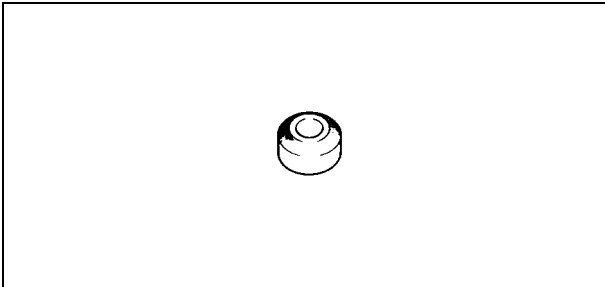

Periodic Maintenance Procedures

Fuel System

High Idle Speed Adjustment

CAUTION

Do not adjust high idle speed with the air cleaner removed.

- Start and warm up the engine throughly.

⚠ WARNING

Always keep your hands clear of the moving parts.

- Move the throttle lever at a dash to the high idle position.
- Loosen the control panel mounting bolts [A] enough to move the control panel assembly.
- Carefully move the control panel assembly right or left to obtain the specified high idle speed.

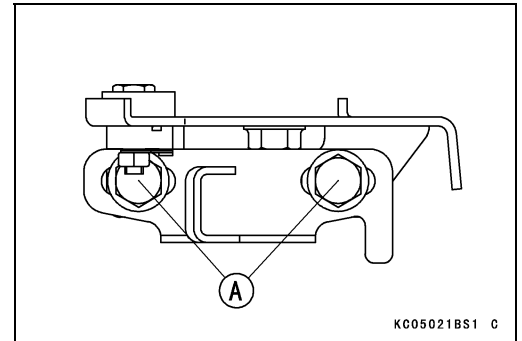

KC05021BS1 C

**High Idle Speed
3200 rpm**

- Tighten the Mounting bolts.

Fuel System Cleanliness Inspection

⚠ WARNING

Gasoline is extremely flammable and can be explosive under certain conditions. Turn the engine switch stop position. Do not smoke. Make sure the area is well-ventilated and free from any source of flame or sparks, this includes any appliance with a pilot light.

- Remove the primer pipe from the tube.
- Place a suitable container [B] under the drain screw [A] on the carburetor.
- Loosen the drain screw to drain the carburetor and check to see if water or dirt has accumulated in the carburetor.
- Tighten the drain screw.

Torque - Drain Screw: 4.2 N·m (0.43 kgf·m, 37 in·lb)

- Install the primer pipe in the tube (see Fuel System chapter).
- If any water or dirt is found, clean the carburetor and fuel tank (see Fuel System chapter).

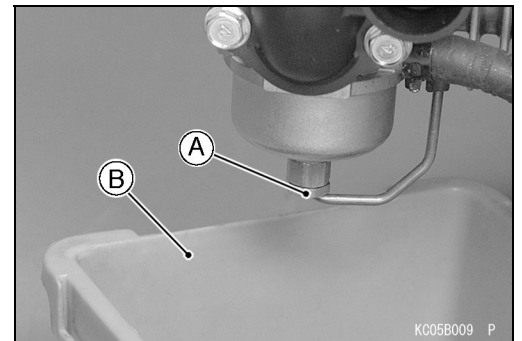

KC05B009 P

2-6 PERIODIC MAINTENANCE

Periodic Maintenance Procedures

Fuel Filter Inspection

- Visually inspect the fuel filter [A].
- ★ If the filter is clear with no signs of dirt or other contamination, it is OK and need not be replaced.
- ★ If the filter is dark or looks dirty, replace with a new one. Also check the rest of the fuel system for contamination.
- Check the O-ring at the tank drain for damage. Replace the O-ring with a new one if it is damaged.

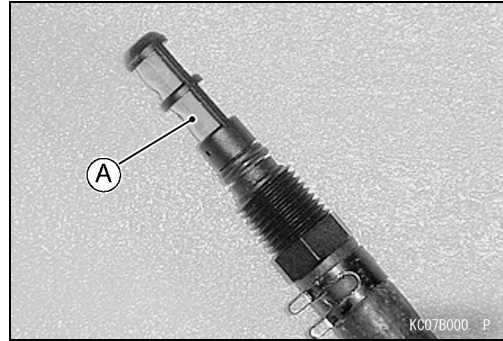

Air Element Removal

- Move the holders [A].

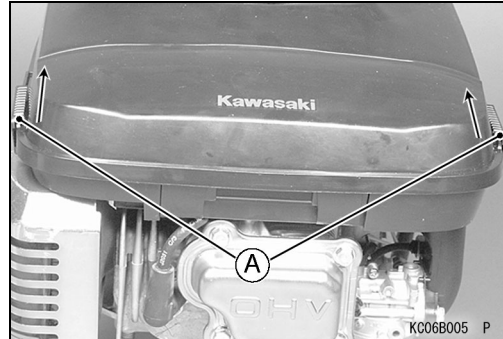

- Push up the latches [A] and remove the air cleaner case [B].

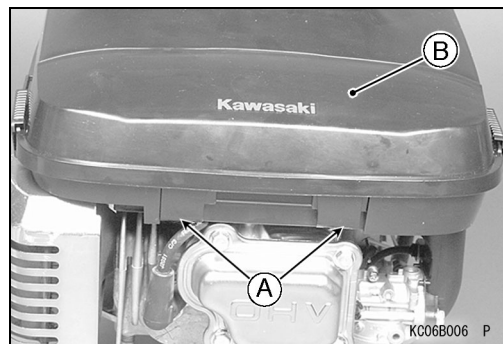

- Remove:
 - Paper Element [A]
 - Foam Element [B]

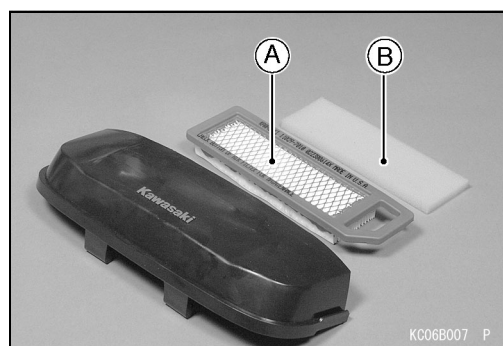

Periodic Maintenance Procedures

Air Element Installation

- Install:
 - Foam Element
 - Paper Element
- Install the hollow [A] of the air cleaner case and projection [B] of the air cleaner body are fitting.

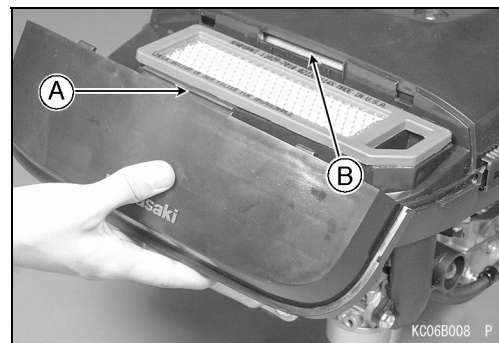

- Move the holders [A].

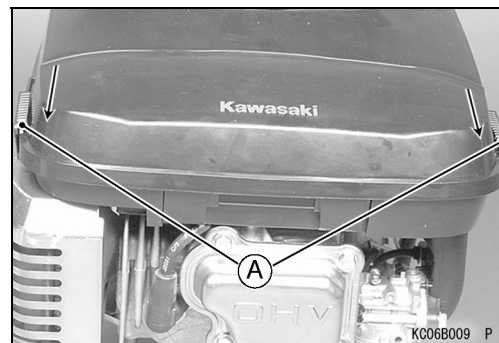

Air Element Cleaning and Inspection

NOTE

○ In dusty areas, the elements should be cleaned more frequently than the recommended intervals.

⚠ WARNING

Because of the danger of highly flammable liquids, do not use gasoline or a low flash-point solvent to clean the element.

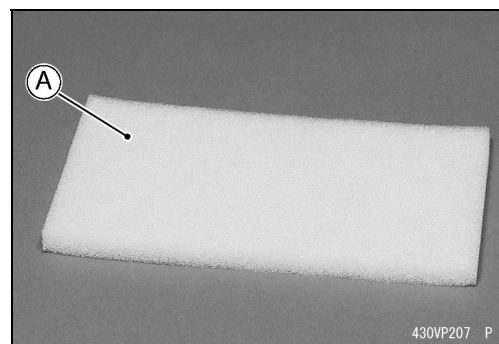

- Remove the paper element and the foam element.
- Clean the foam element [A] in a bath of detergent and water, and let the element air-dry thoroughly before installing it.
- Clean the paper element [A] by tapping it gently on a flat surface to remove dust. If the element is very dirty, replace it with a new one.

CAUTION

Do not use compressed air to clean the paper element. Do not oil the paper or foam element.

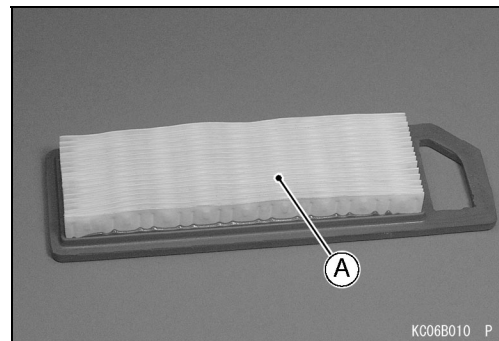

2-8 PERIODIC MAINTENANCE

Periodic Maintenance Procedures

Air Cleaner Housing (Case and Body) Inspection

- Clean the housing with detergent and water and dry thoroughly.
- Check the housing for deformation or other damage. The housing must seal well and permit only filtered air to reach the carburetor.
- ★ If the housing is damaged, it must be replaced.
- Check that no foreign material is obstructing the air passage.

Engine Top End

Cylinder Head Cleaning and Inspection

- Remove the cylinder head (see Engine Top End chapter).
- Scrape the carbon deposits from the head and exhaust port with a suitable tool [A].
- To avoid gouging, use scrapers that are made of a material that will not cause damage.
- Clean the head in a bath of high flash-point solvent and dry it with compressed air.

⚠ WARNING

Clean the cylinder head in a well-ventilated area, and take care that there are no sparks or flame anywhere near the working area, this includes any appliance with a pilot light. Do not use gasoline or a low flash-point solvent to clean the cylinder head. A fire or explosion could result.

- Straight edge [A] across the mating surface of the head at several different points, and measure warp by inserting a thickness gauge [B] between the straightedge and head.
- ★ If warp exceeds the service limit, repair the mating surface. Replace the cylinder head if the mating surface is badly damaged.

Cylinder Head Warp

Service Limit: 0.03 mm (0.001 in.)

- Check the cylinder head for cracks or other damage.
- Cracks not visible to the eye may be detected by using a metal crack detection system (Visual color check: commonly found at automotive parts store.).
- If a crack is present in the cylinder head, replace it.
- Inspect the mating surface for burrs and nicks.

Valve Clearance Inspection

NOTE

○ Valve clearance must be checked when the engine is cold (at room temperature).

- Remove the rocker cover (see Engine Top End chapter).
- Place the piston at top dead center (TDC) of the compression stroke turning the crankshaft rotational direction.

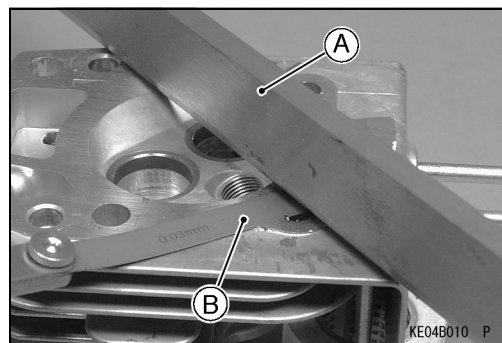
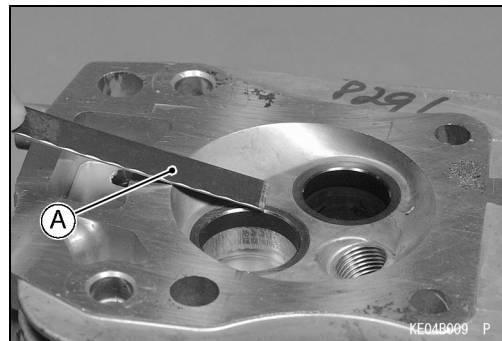

Periodic Maintenance Procedures

- Then check the valve clearance.
- Using a thickness gauge [A], measure the valve clearance between the rocker arm [B] and the valve stem end.
- ★ If the valve clearance is incorrect, adjust it.

Valve Clearance (when cold)
Intake, Exhaust **0.10 ~ 0.15 mm (0.004 ~ 0.006in.)**

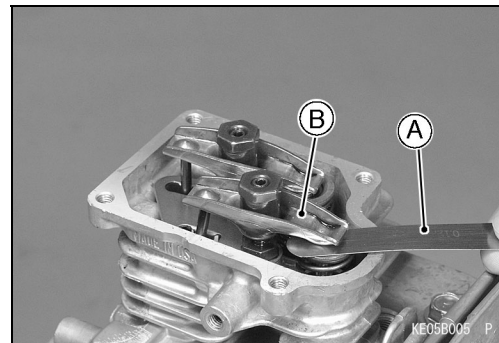

Valve Clearance Adjustment

- Since valve repairs change the valve clearance, adjust the valve clearance to the specification.
- Assemble the cylinder head and install the cylinder head assembly on the block (see Engine Top End chapter).
- Turn the crankshaft to the proper direction until the piston is at TDC of the compression stroke (described above).
- Loosen the lock screws [A] and valve clearance adjusting nuts [B].
- Insert a 0.10 mm (0.004 in.) thickness gauge [C] between the rocker arm and valve stem, and tighten the adjusting nut until the thickness gauge begins to bind between the rocker arm and valve stem end. Use a sweeping motion with the thickness gauge while making this adjustment.

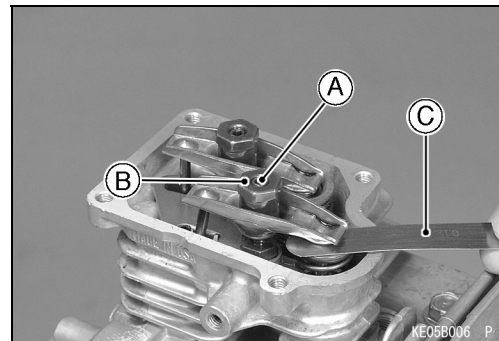

Valve Clearance (when cold)
Intake, Exhaust **0.10 ~ 0.15 mm (0.004 ~ 0.006in.)**

- Holding the adjusting nut with a wrench, tighten the lock screw to the specified torque.

Torque - Valve Clearance Lock Screws: 6.9 N·m (0.70 kgf·m, 61 in·lb)

- Do not overtighten.
- Remeasure any clearance that was adjusted. Readjust if necessary.

Valve Seat Inspection

- Remove the valve (see Engine Top End chapter).
- Inspect the valve seats for damage.
- ★ If the seats are warped or distorted beyond reconditioning, replace the cylinder head.
- Pitted or worn valve seats can be refaced. Lap the valves to the seats after refacing.
- Coat the valve seat with machinist's dye.
- Push the valve into the guide.
- Rotate the valve against the seat with a lapping tool.
- Pull the valve out, and check the seating pattern on the valve head. It must be the correct width [A] and even all the way around.

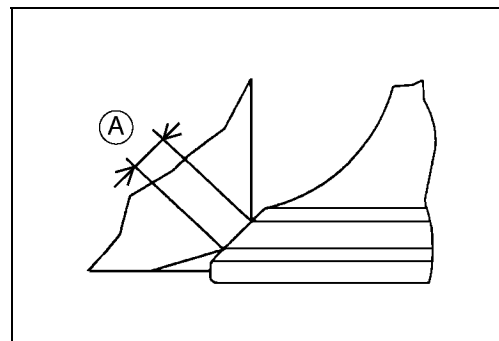

2-10 PERIODIC MAINTENANCE

Periodic Maintenance Procedures

NOTE

○ The valve stem and guide must be in good condition or this check will not be valid.

Good [A]

Too wide [B]

Too narrow [C]

Uneven [D]

★ If the valve seating pattern is not correct, repair the seat.

Valve Seating Surface Width (STD)

Inlet, Exhaust 0.6 ~ 0.9 mm (0.024 ~ 0.035 in.)

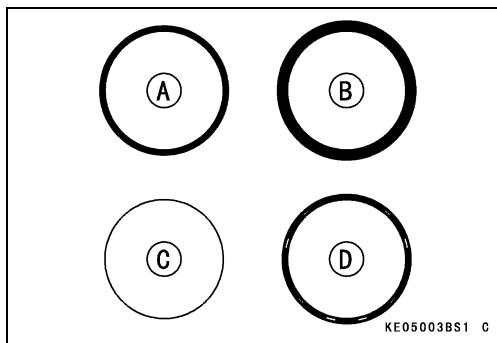

Valve Seat Repair

● Follow the manufacturer's instructions for use of valve seat cutters.

Special Tools

Intake Valve:

Seat Cutter 45° - ϕ 27.5 : 57001-1114

Outside Cutter 32° - ϕ 28.0 : 57001-1119

Exhaust Valve:

Seat Cutter 45° - ϕ 27.5 : 57001-1114

Outside Cutter 32° - ϕ 25.0 : 57001-1118

Valve Seat Cutter Holder- ϕ 6.0 : 57001-1360

Valve Seat Cutter Holder Bar : 57001-1128

★ If the manufacturer's instructions are not available, use the following procedure.

Seat Cutter Operating Cares:

1. This valve seat cutter is designed only for valve seat repair. Therefore the cutter must not be used for other purposes.
2. Do not drop or hit the valve seat cutter, or the diamond particles may fall off.
3. Do not fail to apply engine oil to the valve seat cutter before grinding the seat surface. Also wash off ground particles sticking to the cutter with washing oil.

NOTE

○ Do not use a wire brush to remove the metal particles from the cutter. It will take off the diamond particles.

4. Setting the valve seat cutter holder [A] in position, operate the cutter [B] with one hand [C]. Do not apply too much force to the diamond portion.

NOTE

○ Prior to grinding, apply oil to the cutter, and during the operation wash off any ground particles sticking to the cutter with washing oil.

5. After use wash the cutter with washing oil and apply a thin layer of engine oil before storing.

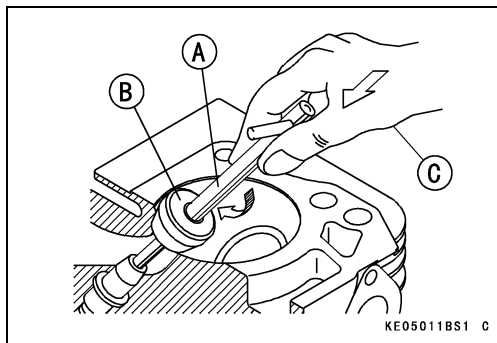

Periodic Maintenance Procedures

Marks Stamped on the Cutter:

The marks stamped on the back of the cutter represent the following.

- | | |
|------|--------------------------------------|
| 1 | Cutter number, selected from 1 to 12 |
| 30° | Cutter angle [A] |
| 37.5 | Cutter diameter of cutter [B] |
| KS8B | Manufactured lot number |

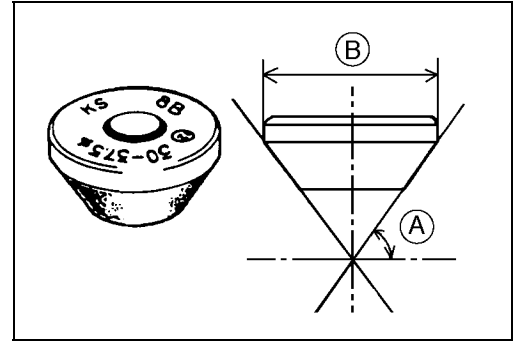

Operating Procedures:

- Clean the seat area carefully.
 - Recondition the valve seats with the valve seat cutters (45°, 32°) and lap the valves.
 - Check the seats for good contact all the way around with machinist's dye.
 - Measure the seat width [A]. If it is more than the STD width, the seating surface should be refaced.
 - If the valve seating pattern is not correct, repair the seat.
-
- Coat the seat with machinist's dye.
 - Fit a 45° seat cutter [A] to the holder and slide it into the valve guide.
 - Resurface the valve seat with a 45° cutter, removing only enough material to produce a smooth and concentric seat.

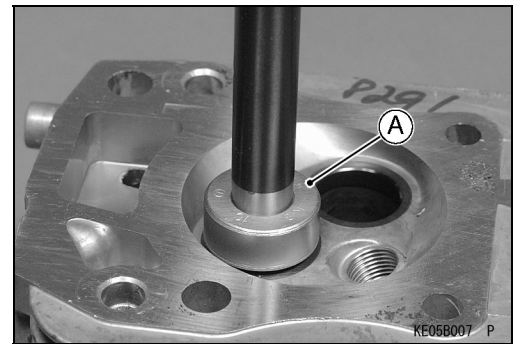
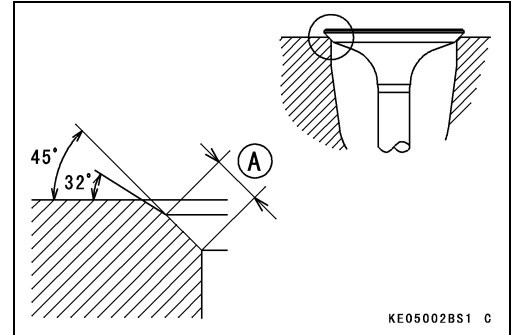

CAUTION

Do not grind the seat too much. Overgrinding will reduce valve clearance by sinking the valve into the head. If the valve sinks too far into the head, it will be impossible to adjust the clearance, and the cylinder head must be replaced. Do not turn the cutter counterclockwise or drop it against the seat, or it will be dulled.

2-12 PERIODIC MAINTENANCE

Periodic Maintenance Procedures

- Use a 32° seat cutter [A] to narrow the seat width to the STD width.
- Turn the seat cutter one turn at a time while pressing down very lightly. Check the seat width after each turn.

CAUTION

The 32° cutter removes material very quickly. Check the seat width frequently to prevent over grinding.

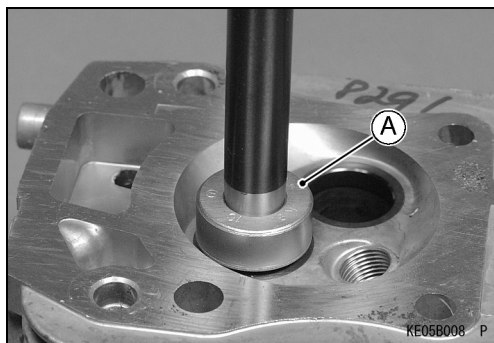

NOTE

- Keep the seat width as close as possible to the STD width.
- Make a light pass with the 45° cutter to remove any possible burrs at the edge of the seat.
- After resurfacing the seat, inspect for even valve seating.
- Apply a machinist's dye to the valve face, insert the valve, and snap it closed against the seat several times. The valve surface should show good contact all the way around. Be sure the valve seat is centered on the valve face. The position of the valve in the seat is evident after lapping the valve.
- ★ If the seat does not make proper contact, lap the valve into seat with a vacuum cap tool.
- Coat the face of valve sparingly with a fine lapping compound.
- Use the vacuum cup tool [A], to grip top of the valve [B]. Rotate the valve in a circular motion to lap the valve to the seat.
- Lift the valve slightly from the seat every 8 to 10 strokes, continue lapping operation until a uniform ring appears around entire surface of the valve face.

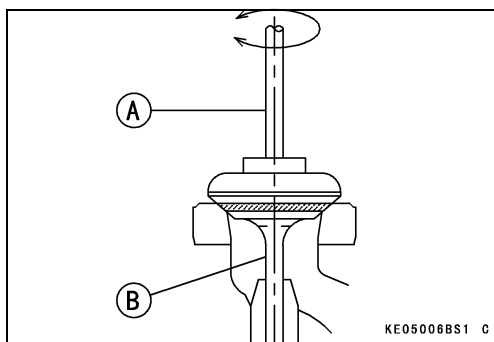

- When lapping is completed, wash all parts in solvent to remove lapping compound. Dry the parts thoroughly.
- Note the position of the lapping mark on the valve face. The lapping mark should appear on or near the center of the valve face.
- When the engine is assembled, be sure to adjust the valve clearances (see Valve Clearance Adjustment).

Periodic Maintenance Procedures

Lubrication System

Oil Level Inspection

- Place the engine on a level surface.
- Remove the oil filler cap [A] and wipe its dipstick [B] with a clean cloth.
- Insert the dipstick into gauge hole [C] without screwing it in, then check the oil level.

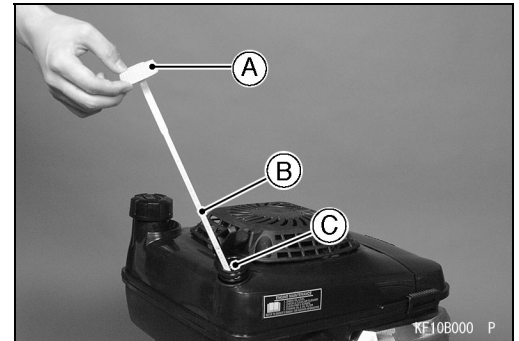

- The oil level should be the operating range [A] (grid area) on the dipstick.
- ★ If the oil level is below “ADD” range [B], add enough engine oil to bring oil level to the operating range.

CAUTION

Do not add more oil above the operating range. Excess oil will cause a smoking condition.

- Use the same type and make of oil that is already in the engine.

NOTE

- If the engine oil type and make are unknown, use any brand of the specified oil to top up the level in preference to running the engine with the oil level low. Then at your earliest convenience, change the oil completely.
- ★ If the oil level is above “FULL” range [C], drain the excess oil by loosening the drain plug.

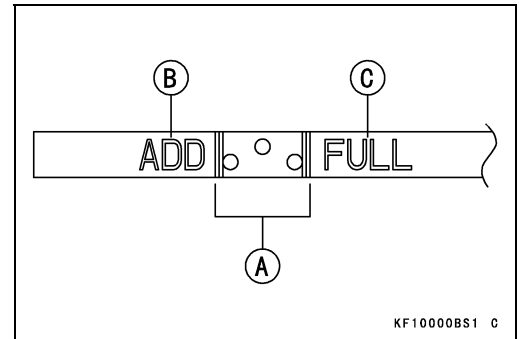

Oil Change

- Change the oil after first 8 hours of operation. Thereafter change oil every 100 hours.
- Start and warm up the engine so the oil will drain easily. Stop the engine.
- Place the engine on a level surface.
- Place a suitable container under the engine.
- Remove the drain plug [A] and drain the oil.

⚠ WARNING

Be careful of hot oil when drained. It may be hot enough to burn you severely.

- Check the washer [B] at the drain plug for damage. Replace the washer with a new one if it is damaged.
- Install the drain plug with the washer and tighten it.

Torque - Oil Drain Plug : 22 N·m (2.2 kgf·m, 16 ft·lb)

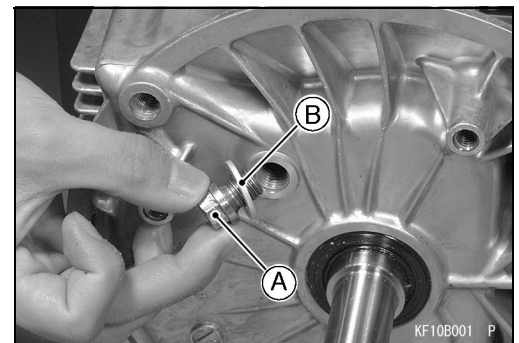

2-14 PERIODIC MAINTENANCE

Periodic Maintenance Procedures

- Remove the oil filler cap and pour in the specified type and amount of oil.

Engine Oil :

Type: SF, SG, SH or SJ Class
Viscosity: SAE30, SAE10W-30
Capacity: [When engine is completely dry]
0.65 L (0.69 US-qt)

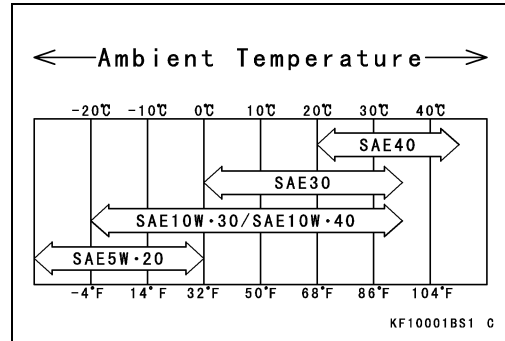

Electrical System

Spark Plug Cleaning and Inspection

- Remove the spark plug (See Electrical System chapter).
- ★ If the plug is oily or has carbon build up on it, clean the plug using a high flash-point solvent and a wire brush or other suitable tool.
- ★ If the spark plug electrodes are corroded or damaged, or if the insulator is cracked, replace the plug. Use the standard spark plug or its equivalent.

Insulator [A]
Center Electrode [B]
Plug Gap [C]
Side Electrode [D]

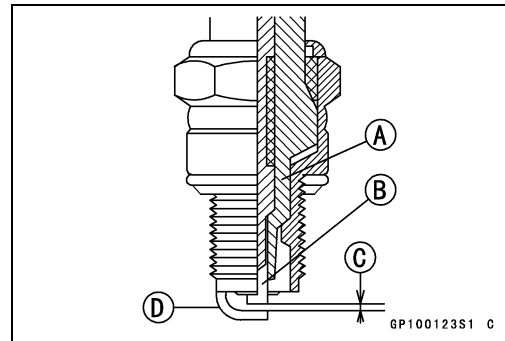

Spark Plug Gap Inspection

- Measure the gap with a wire-type thickness gauge.
- ★ If the gap is incorrect, carefully bend the side electrode with a suitable tool to obtain the correct gap.

Spark Plug Gap Standard: 0.75 mm (0.030 in.)

Fuel System

TABLE OF CONTENTS

Exploded View	3- 2
Specifications	3- 6
Governor Link Mechanism.....	3- 7
Control Panel Assembly Removal	3- 7
Control Panel Assembly Installation	3- 7
Governor Arm Removal	3- 7
Governor Arm Installation	3- 8
Governor Assembly Inspection and Removal.....	3- 8
Governor Assembly Installation	3- 9
Governor Shaft Removal	3- 9
Governor Shaft Installation	3- 9
Carburetor	3-10
Fuel and Air Flow	3-10
High Idle Speed Adjustment	3-11
High Altitude Operation.....	3-11
Main Jet Replacement	3-11
Fuel System Cleanliness Inspection	3-12
Carburetor Removal.....	3-12
Carburetor Installation.....	3-12
Carburetor Disassembly/Assembly	3-13
Carburetor Cleaning.....	3-14
Carburetor Inspection	3-15
Priming Pump	3-16
Priming Pump Removal	3-16
Priming Pump Installation	3-16
Intake Manifold	3-17
Intake Manifold Removal	3-17
Intake Manifold Installation	3-17
Intake Manifold Inspection	3-17
Fuel Tank.....	3-18
Fuel Tank Removal	3-18
Fuel Tank Installation	3-18
Fuel Tank Cleaning	3-19
Fuel Filter.....	3-20
Fuel Filter Inspection.....	3-20
Air Cleaner.....	3-21
Element Removal	3-21
Element Installation.....	3-21
Element Cleaning and Inspection	3-21
Cleaner Body Removal	3-21
Cleaner Body Installation	3-21
Housing (Case and Body) Inspection	3-22

3-2 FUEL SYSTEM

Exploded View

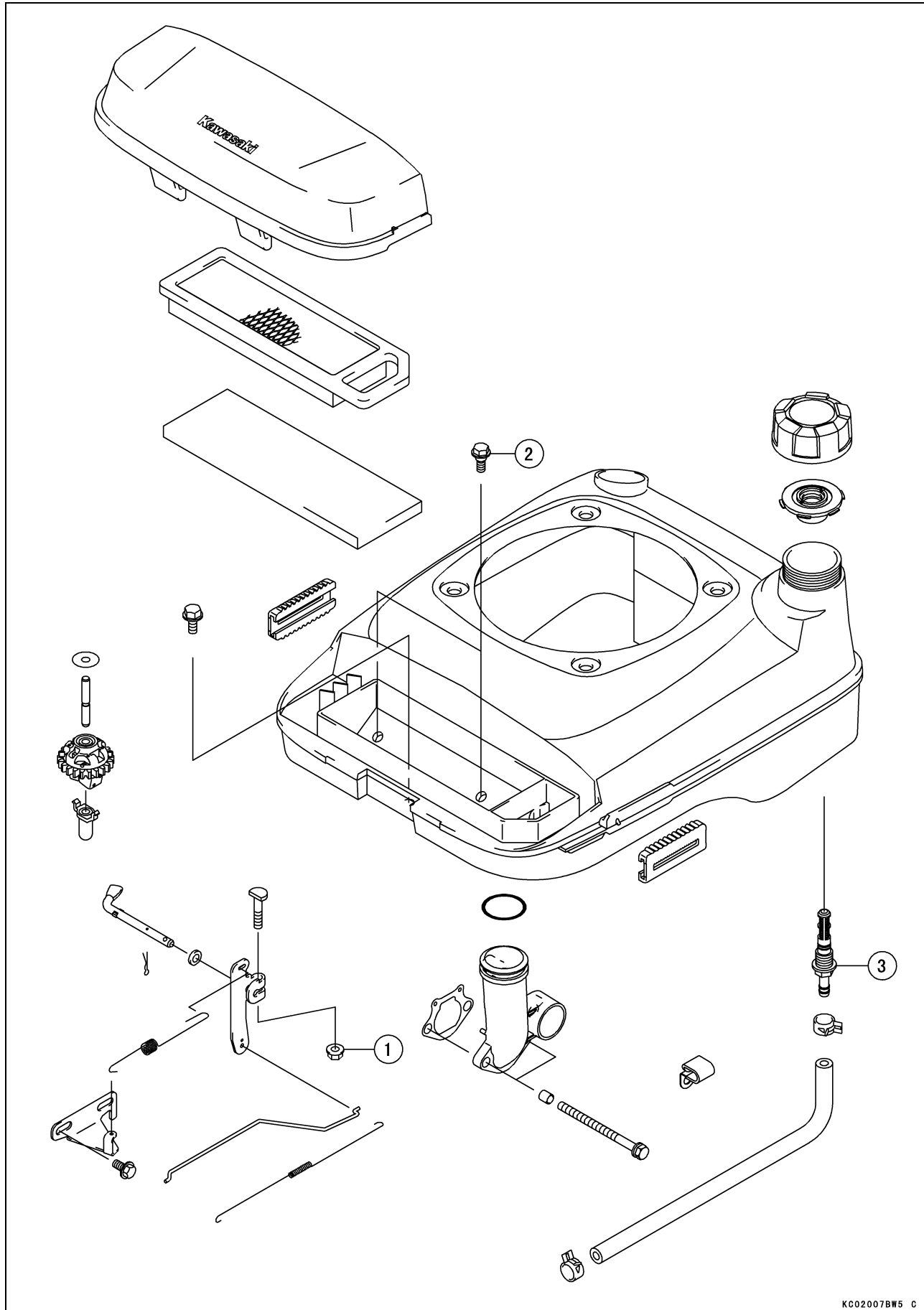

KC02007BW5 C

Exploded View

No.	Fastener	Torque			Remarks
		N·m	kgf·m	ft·lb	
1	Govenor Arm Clamp Nut	7.8	0.80	69 in·lb	
2	Fuel Tank Cover Bolts	6.9	0.70	61 in·lb	
3	Tank Drain Bolt	6.9	0.70	61 in·lb	

Exploded View

No.	Fastener	Torque			Remarks
		N·m	kgf·m	ft·lb	
1	Priming Nut	1.2	0.12	11 in·lb	
2	Throttle Valve Screw	0.7	0.07	6 in·lb	
3	Main Jet	1.1	0.11	9.7 in·lb	
4	Float Chamber Mounting Bolt	5.4	0.55	48 in·lb	
5	Drain Screw	4.2	0.43	37 in·lb	

3-6 FUEL SYSTEM

Specifications

Item	Standard
	FJ180V
Carburetor Specification:	
Make/ type	Walbro LMJ-17A
Throttle bore diameter	20 mm (0.79 in.)
Venturi diameter	14 mm (0.55 in.)
Main Jet (MJ)	#76
Pilot jet (PJ)	#50
Pilot air screw turns out (PS) (Idle mixture screw turns out)	2 3/4
Float level	Float parallel to carburetor body
High idle speed	3200 r/min (rpm)
Air Cleaner:	
Type	Dual stage filtration system
Pre-cleaner	Foam element
Second-stage cleaner	Paper element
Fuel:	
Fuel requirement	Unleaded regular grade gasoline
Governor:	
Type	Flyweight all speed governor

Governor Link Mechanism

Control Panel Assembly Removal

- Remove:
 - Air Cleaner (see Cleaner Body Removal)
 - Recoil Starter (see Electrical System chapter)
 - Fuel Tank (see Fuel Tank Removal)
 - Control Panel Mounting Bolts [A]

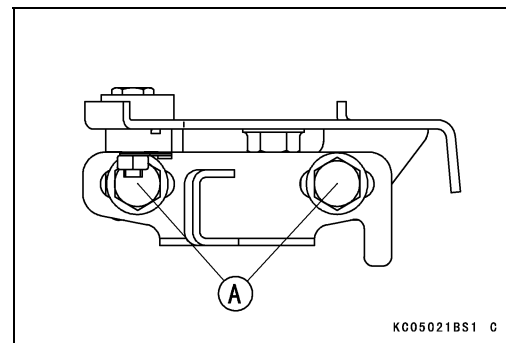

- Remove the control panel [B] unhooking the governor spring [A] end loop at the panel bracket.

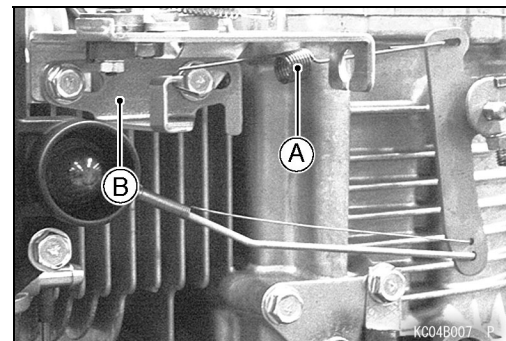

Control Panel Assembly Installation

- ★ If any part is worn or damaged, replace the control panel.
- Install the control panel.
- Tighten the control panel mounting bolts.
- Hook the governor spring end loop [A] at the panel bracket [B].
- After installation, adjust the high idle speed to the specifications (see Periodic Maintenance chapter).

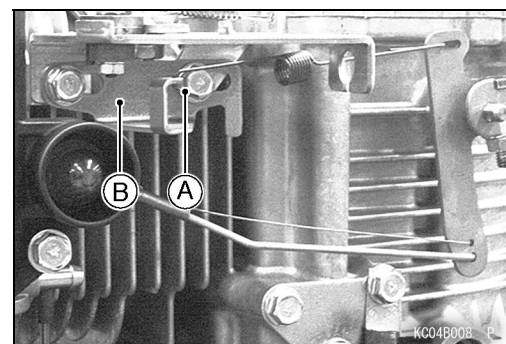

Governor Arm Removal

- Remove:
 - Control Panel Assembly
- Loosen the clamp nut [A] and take off the governor arm [B].
- Unhook the throttle link rod spring [C] end loop and clear the throttle link rod lower end [D].

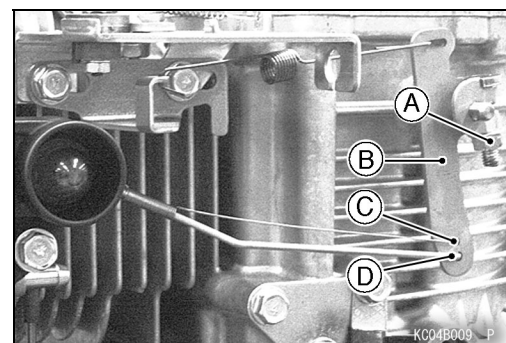

3-8 FUEL SYSTEM

Governor Link Mechanism

Governor Arm Installation

- Install the governor arm [A] onto the governor shaft [B] temporarily.
- Be sure the link spring [C] around the throttle link rod [D] is in place and that it pulls the governor arm and throttle lever [E] toward each other.
- Loosen the clamp nut [F] on the governor arm enough to move the governor shaft.
- Turn the top end of the governor arm counterclockwise [G] to fully open the carburetor throttle valve and hold it there.
- Turn the governor shaft counterclockwise, fully turn the shaft to end of its travel.
- There should be no gap between the governor arm and the snap pin on the governor shaft.
- Tighten the clamp nut.

Torque - Governor Arm Clamp Nut: 7.8 N·m (0.80 kgf·m, 69 in·lb)

- Install the control panel assembly, and connect the governor arm with the governor spring.

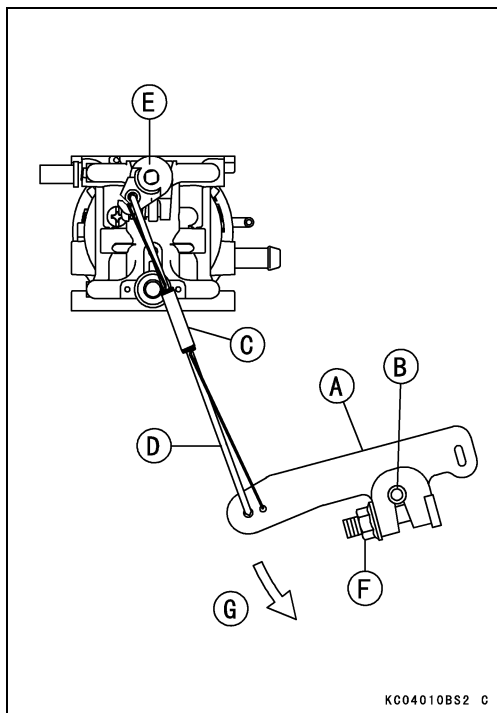

Governor Assembly Inspection and Removal

- Remove the crankcase cover (see Camshaft/Crankshaft chapter).
- Visually check the governor assembly as built in the crankcase cover for damage or wear.

CAUTION

Do not remove the governor assembly unless the parts are to be replaced. The parts cannot be reused once they are removed.

- When removing the governor gear assembly [A] for replacing, use two screw drivers [B] of an appropriate size.

CAUTION

Protect the gasket-mount surface of the crankcase cover when removing the governor assembly with the screw drivers.

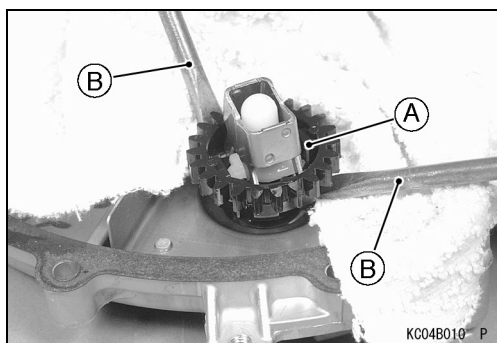

Governor Link Mechanism

Governor Assembly Installation

- Install the sleeve [A] on the governor assembly [B].

CAUTION

First install the sleeve. The sleeve cannot be installed after the governor gear assembly has been installed.

- To install, first place the thrust washer [C] on the boss of the shaft [D]. Then, install the governor assembly (with the sleeve attached) on the shaft so that step [E] is fitted securely in groove [F].
- After installing the assembly, turn the governor by hand to make sure that the governor weight [G] and the sleeve move smoothly.

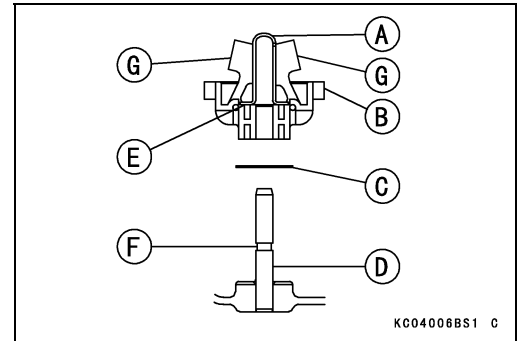

Governor Shaft Removal

- Remove:
 - Air Cleaner (see Fuel System chapter)
 - Recoil Starter (see Electrical System chapter)
 - Fuel Tank (see Fuel System chapter)
 - Governor Arm (see Governor Arm Removal)
 - Flywheel (see Electrical System chapter)
 - Crankcase Cover (see Camshaft/Crankshaft chapter)
 - Crankshaft (see Camshaft/Crankshaft chapter)
- Remove:
 - Snap Pin [A]
 - Governor Shaft [B]
 - Washer [C]

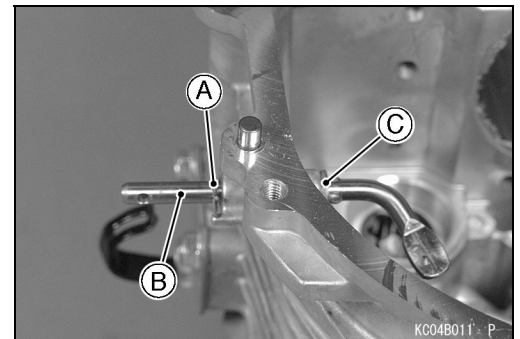

Governor Shaft Installation

- Apply engine oil to the governor shaft.
- Install:
 - Washer [A]
 - Governor Shaft [B]
 - Snap Pin [C]
- Check that the governor shaft moves freely in its operating range.

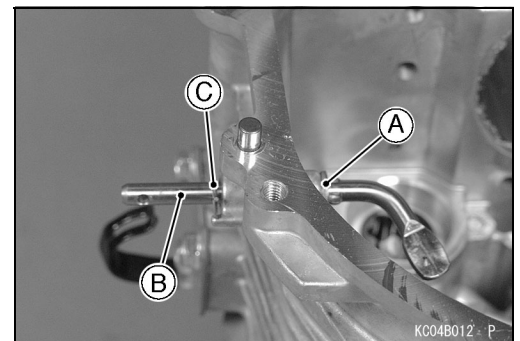

3-10 FUEL SYSTEM

Carburetor

Fuel and Air Flow

The main system of the carburetor consists of the main jet [A], main nozzle [B], and the main air passage [C] (main air jet [D]). The main system meters fuel to the engine during moderate to high load conditions. Fuel flows through the main jet and into the main nozzle, where it is joined by air from the main air passage (main air jet). The resulting mixture flows out the end of the main nozzle into the carburetor bore, where it is atomized by the high speed air flow, and carried into the engine.

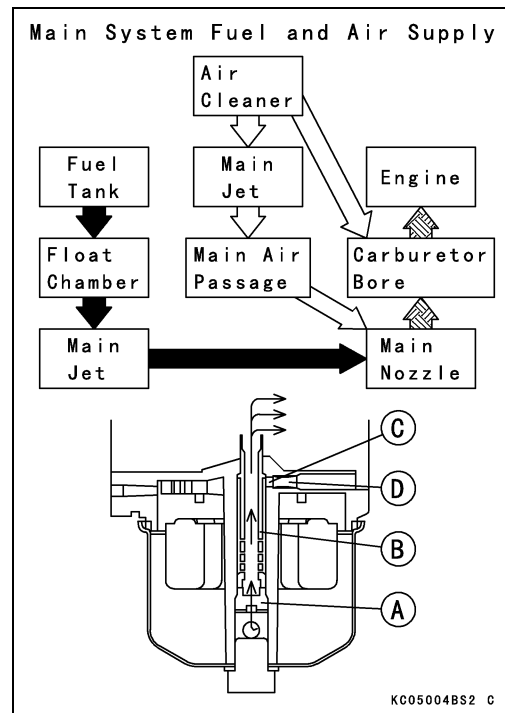

The pilot system includes the pilot jet [E], pilot screw [F] (Idle mixture screw), pilot air jet [G], pilot outlet [H], and the bypass holes [I]. The pilot system meters the fuel/air mixture while the engine is idling and running under a light load. Under these conditions there is very little air flow through the carburetor bore, so little that it is not enough to draw fuel through the main system of the carburetor and atomize it. Instead, the fuel is drawn through the pilot system, since the nearly closed throttle valve [J] causes high speed air flow past the pilot outlet and bypass holes (even at low engine speed).

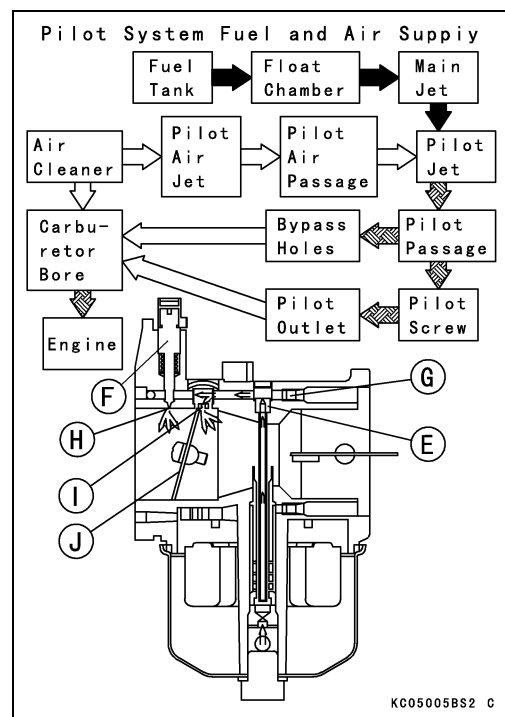

Fuel flow in the pilot system is metered by the pilot jet. Air for better atomization is admitted via the pilot air jet in the mouth of the carburetor. The fuel/air mixture passes into the bore of the carburetor side stream of the throttle valve through the bypass holes and pilot outlet. While the throttle valve is almost closed, it covers the small bypass holes opening into the bore from the pilot system. As the throttle valve begins to open, it uncovers the bypass holes, allowing more fuel/air mixture to flow. The extra flow is needed because the engine starts to run faster as the throttle is opened. The pilot screw controls the amount of fuel/air mixture allowed through the pilot outlet, but does not meter the bypass holes. A moderate amount of air comes in around the throttle valve at idle, so adjusting the pilot screw changes the fuel/air ratio. Turning the pilot screw (Idle mixture screw) out (Counterclockwise) enriches the mixture; turning it in (clockwise) leans the mixture.

- Main Fuel Flow →
- Pilot Fuel Flow ⇒

Carburetor

High Idle Speed Adjustment

- Refer to High Idle Speed Adjustment in the Periodic Maintenance Chapter (2nd chapter).

High Altitude Operation

At high altitude, the standard carburetor air-fuel mixture will be excessively rich. Performance will decrease, and fuel consumption will increase. High altitude performance can be improved by installing a smaller diameter main jet in the carburetor and correct high idle speed.

NOTE

- The main jet high altitude kits are available if the equipment is to be used in the high altitudes. The main jet numbers are stamped on ends of the main jets.

High Altitude Main Jet

	Main Jet No.
Altitude	FJ180V
0 ~ 1 000 m (0 ~ 3 000 ft)	92063-7048
1 000 ~ 2 000 m (3 000 ~ 6 000 ft)	92063-7049
2 000 m (6 000 ft) and higher	92063-7050

Main Jet Replacement

- Place the engine on a level surface.
- Remove the tube [A] from the primer pipe.
- Drain the fuel in the carburetor completely by unscrewing the drain screw [B] at the bottom of the float chamber.
- Remove the carburetor (see Carburetor Removal).
- Unscrew the float chamber mounting bolt [C] and take off the float chamber [D] and gasket.

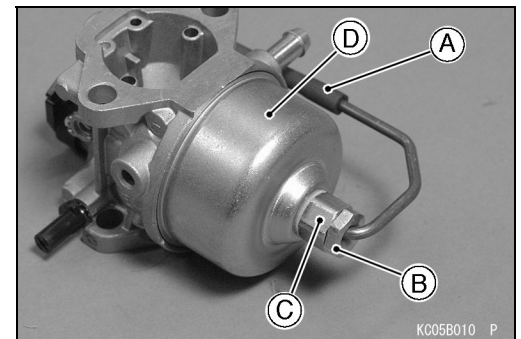

- Using a properly sized blade screw driver, carefully replace the main jet [A] with a new one for altitude expected.
- Tighten the main jet to the specification (see Carburetor Disassembly Assembly Notes).
- Install the float chamber and gasket.
- Tighten float chamber mounting bolt.

Torque - Float Chamber Mounting Bolt: 5.4 N·m (0.55 kgf·m, 48 in·lb)

- Install the tube on the primer pipe (see Priming Pump Installation).

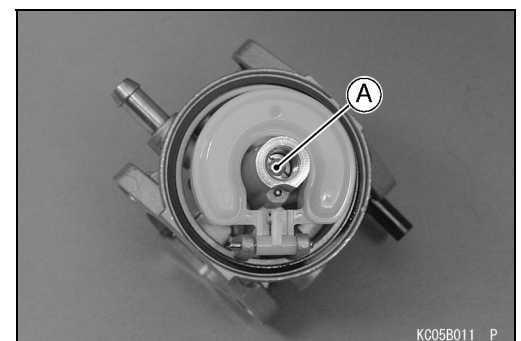

3-12 FUEL SYSTEM

Carburetor

- Install the primer pipe [A] and drain screw as shown.
90° ~ 100° [B]

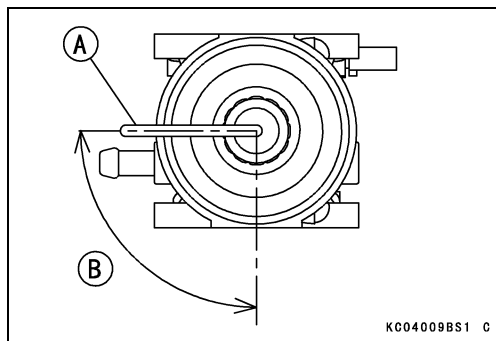

Fuel System Cleanliness Inspection

- Refer to Fuel System Cleanliness Inspection in the Periodic Maintenance Chapter (2nd chapter).

Carburetor Removal

⚠ WARNING

Gasoline is extremely flammable and can be explosive under certain conditions. Turn the engine switch stop position. Do not smoke. Make sure the area is well-ventilated and free from any source of flame or sparks, this includes any appliance with a pilot light.

- Remove the tube from the primer pipe.
- Place a suitable container beneath the fuel hose.
- Disconnect the fuel hose from the carburetor.
- Drain the fuel in the carburetor completely by unscrewing the drain screw at the bottom of the float chamber.
- Remove the intake manifold (see Intake Manifold Removal).
- Remove the carburetor.
- Unhook the throttle link spring [B] and throttle link rod [C] at the throttle shaft lever [A] top end with a long nose pliers.

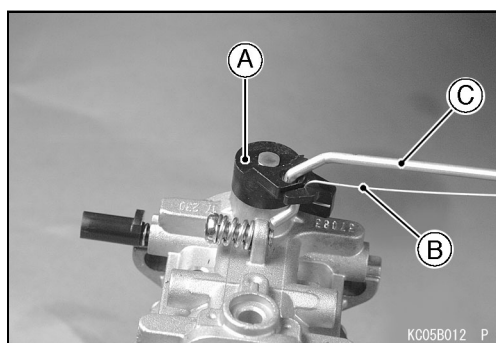

Carburetor Installation

- Clean the mating surfaces of the carburetor and intake manifold, and fit the new gaskets.
- Take care not to bend the throttle during installation. Make sure the link spring around the throttle link rod is in place and that it pulls the governor arm and carburetor throttle shaft lever toward each other.
- Adjust:
High Idle Speed

Carburetor

Carburetor Disassembly/Assembly

- Refer to the illustration shown for disassembly and assembly.
- There are several passage plugs (Ball plugs) in the carburetor body. Do not remove.
- Before disassembly, mark the out side of throttle valve for assembling them.
- Replace the pilot screw in accordance with the following procedure if necessary.
 - Carefully mark the position of the pilot screw limiter on the carburetor body so that it can be installed and set to its original position later.
 - Remove the limiter. Be careful not to turn pilot screw at this point.
 - Turn the pilot screw clockwise and count the number of turns until screw is gently seated in the pilot passage. Record the number of turns needed to closed the screw.
 - Turn out the pilot screw to replace it with a new one.
 - Install the new pilot screw until the screw is gently seated. Then open the screw the same number of turns as recorded prior to removal.
- Align the limiter with the mark on the carburetor body to install, taking care not to turn the pilot screw.
- Install the throttle valve on the shaft as the out side mark of them facing out side.
- Drive the float pin into the carburetor body from the limiter side.
- Assemble carburetor parts with recommended tightening torque (see Exploded View).

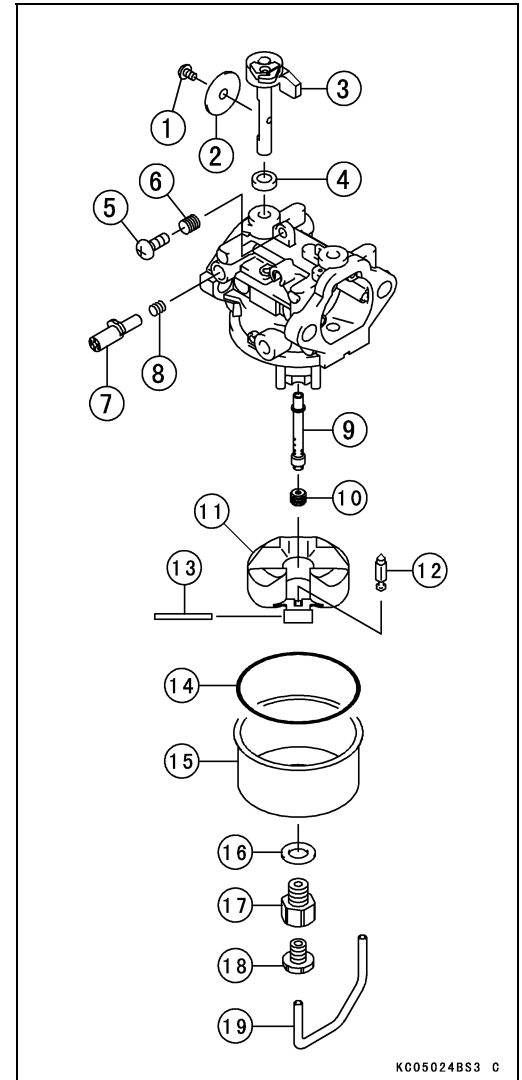

1. Throttle Valve Screw
2. Throttle Valve
3. Throttle Shaft
4. Seal
5. Screw
6. Spring
7. Limiter
8. Spring
9. Main Nozzle
10. Main Jet
11. Float
12. Needle Jet
13. Float Pin
14. Gasket
15. Float Chamber
16. Gasket
17. Float Chamber Mounting Bolt
18. Drain Screw
19. Primer Pipe

3-14 FUEL SYSTEM

Carburetor

Carburetor Cleaning

⚠ WARNING

Clean the carburetor in a well-ventilated area, and take care that there is no sparks or flame anywhere near the working area, this includes any appliance with a pilot light. Because of the danger of highly flammable liquids, do not use gasoline or low flash-point solvents to clean the carburetor.

CAUTION

Do not use compressed air on an assembled carburetor, or the float may be crushed by the pressure. Remove as many rubber or plastic parts from the carburetor as possible before cleaning the carburetor with a cleaning solution. This will prevent to damage or deterioration of the parts.

The carburetor body has plastic parts that cannot be removed. Do not use a strong carburetor cleaning solution which could attack these parts instead, use a mild high flash-point cleaning solution safe for plastic parts.

Do not use wire or any other hard instrument to clean carburetor parts, especially jets, as they may be damaged.

- Disassemble the carburetor.
- Immerse all the carburetor metal parts in a carburetor cleaning solution and clean them.
- Rinse the parts in water and dry them with compressed air.
- Do not use rags or paper to dry parts. Lint may plug the hole or passages.
- Blow air through the holes and fuel passages with the compressed air. All holes must be open.
- Assemble the carburetor.

Carburetor

Carburetor Inspection

⚠ WARNING

Gasoline is extremely flammable and can be explosive under certain. Turn the engine switch stop position. Do not smoke. Make sure the area is well ventilated and free from any source of flame or sparks this includes any appliance with a pilot light.

- Inspect the carburetor body for damage. Flange sealing surfaces should be smooth and free of burrs and nicks. Replace the gasket if necessary.
- Turn the throttle shaft to check that the throttle butterfly valve move smoothly.
- ★ If the valve do not move smoothly, replace the carburetor body and/or throttle shaft.
- Check the gasket on the carburetor body.
- ★ If the gasket is not in good condition, replace it.
- Check the other parts of the carburetor for wear or damage. Replace the part if necessary.
- Clean and check the float level as follows.

CAUTION

Do not push down on the float during float level checking.

- With the float [A] assembly installed onto the carburetor body, hold the carburetor upside down at eye level. Gently support the float with a finger and bring it down slowly so that the float arm tab [B] touches the float valve [C]. The float lower surface [D] should be parallel with the carburetor body mating surfaces.
- ★ If the float position is not correct, replace the float with a new one.

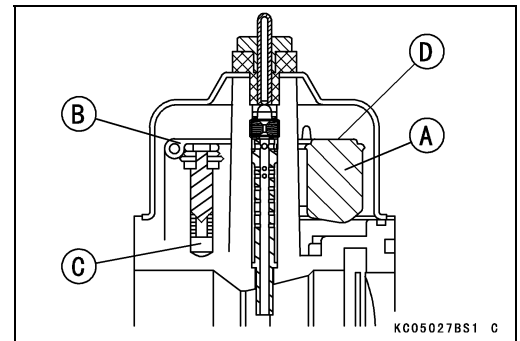

- Inspect the float valve for excessive wear or damage. The tip should be smooth, without any grooves, scratches, or tears. The rod at the other end of the needle should move smoothly when push in and released.

Good [A]

Bad [B]

- ★ If either the needle or the seat is worn or damaged, replace the float assembly and carburetor body as a set.

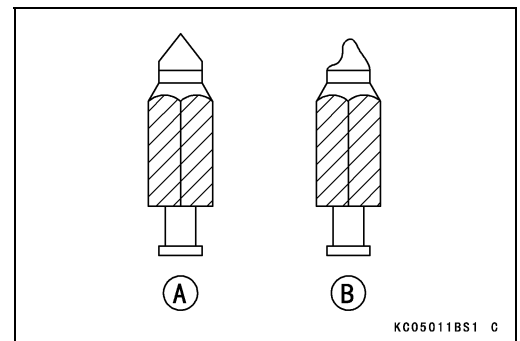

3-16 FUEL SYSTEM

Priming Pump

Priming Pump Removal

- Remove the tube [A] from the priming pump.
- Remove the nut [B] and washer [C].
- Remove the priming pump from the intake manifold.
- Inspect the priming pump for damages.
- ★ If a damage is present in the priming pump, replace it.

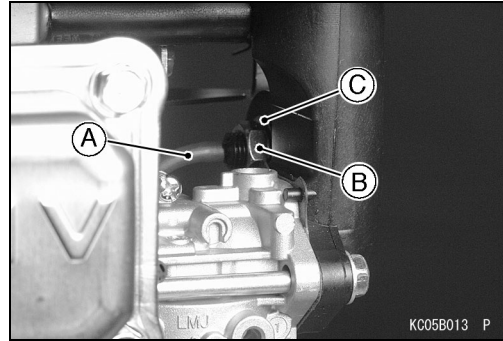

Priming Pump Installation

- Install the priming pump in the intake manifold.
- Install the washer [A] and tighten the nut [B].
- Torque - Priming Nut: 1.2 N·m (0.12 kgf·m, 11 in·lb)**
- Install the tube [C] on the priming pump.

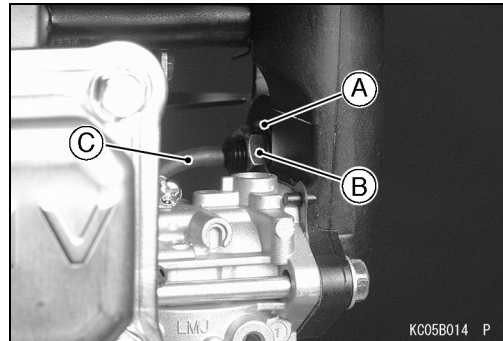

- Install the tube [B] on the primer pipe [A] as shown.
8 ~ 10 mm [C]

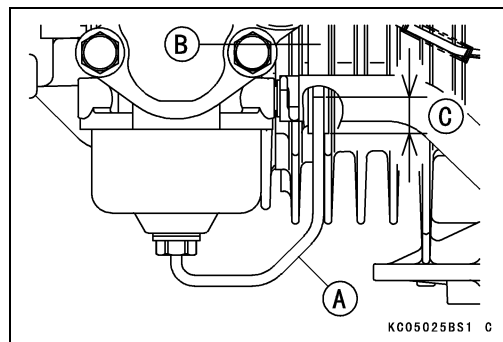

Intake Manifold

Intake Manifold Removal

- Unscrew the intake manifold mounting bolts [A].
- Remove the breather pipe [B] from the intake manifold.

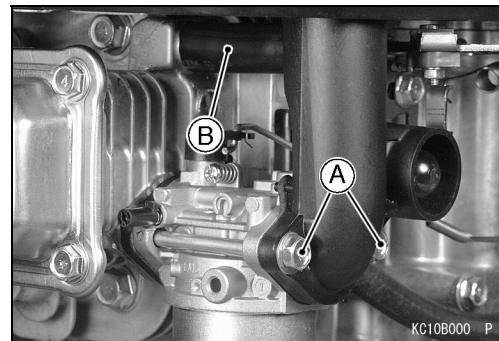

Intake Manifold Installation

- Replace the O-ring [A] with a new one.
- Clean the mating surface of the carburetor and intake manifold.

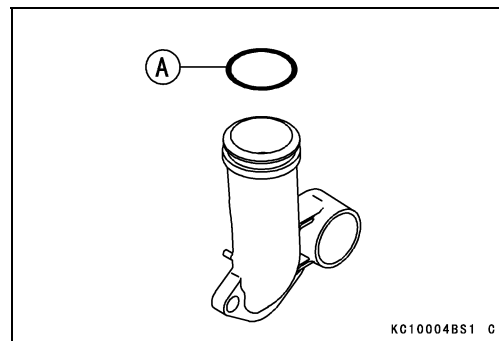

- Clean the mating surface of the carburetor and intake manifold and install the new gasket [A] and intake manifold.

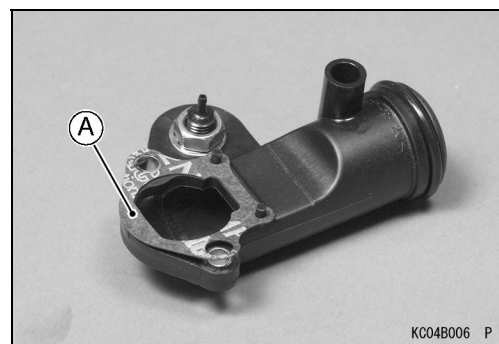

- Install the spacers [A] and tighten the intake manifold mounting bolts [B].
- Do not clearance between intake manifold and fuel tank.

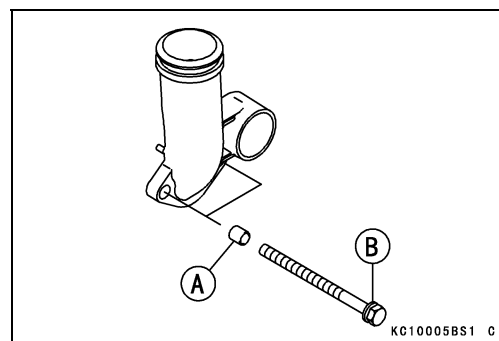

Intake Manifold Inspection

- Inspect the intake manifold for cracks.
- Cracks not visible to the eye may be detected by using a metal crack detection system (Visual color check: commonly found at automotive parts store.).
- ★ If a crack is present in the intake manifold, replace it.
- Inspect the gasket surfaces for burrs and nicks.

3-18 FUEL SYSTEM

Fuel Tank

Fuel Tank Removal

- Remove:
 - Air Cleaner (see Cleaner Body Removal)
 - Recoil Starter (see Electrical System chapter)
 - Oil Gauge
 - Fuel Tank Cover Bolts [A].

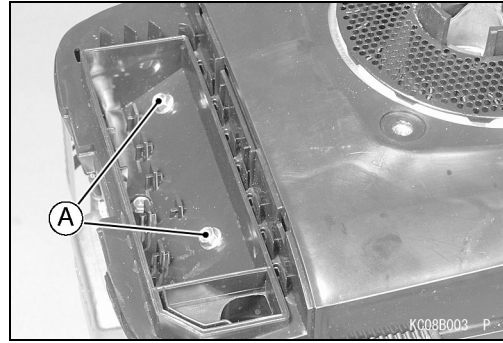

- Place a suitable container beneath the fuel hose.
- Loosen the clamp and remove the fuel hose from the carburetor.
- Loosen the clamp and remove the fuel hose from the tank drain.
- Remove the fuel tank.
- Remove the tank drain from the fuel tank.

Fuel Tank Installation

- Install the tank drain [A] in the fuel tank as shown.
- When tightening the tank drain, nut must contact fuel tank cover.

Torque - Tank Drain Bolt: 6.9 N·m (0.70 kgf·m, 61 in·lb)

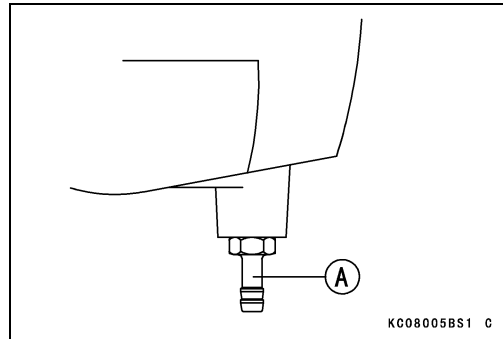

- Install the fuel tank.
- When installing the fuel tank, don't clearance between intake manifold [A] and fuel tank [B].

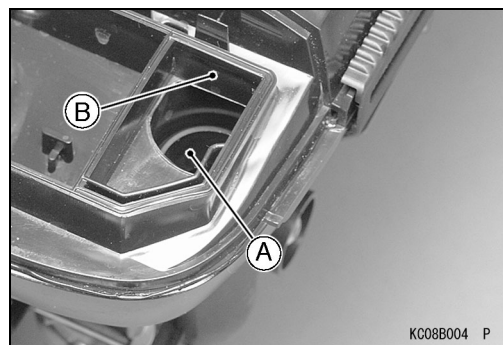

- Install the fuel hose on the tank drain.
- Install the fuel hose on the carburetor.
- Tighten the fuel tank cover bolts.
 - Torque - Fuel Tank Cover Bolts: 6.9 N·m (0.70 kgf·m, 61 in·lb)**
- Install the other removed parts.

Fuel Tank

Fuel Tank Cleaning

⚠ WARNING

Clean the fuel tank in a well-ventilated area, and take care that there is no sparks or flame anywhere near the working area. Because of the danger of highly flammable liquids, do not use gasoline or low flash-point solvent to clean the tank.

- Remove the fuel tank (see Fuel Tank Removal).
- Pour the solvent out of the tank.
- Pour some high flash-point solvent into the fuel tank and shake the tank to remove dirt and fuel deposits.
- Dry the fuel tank with compressed air.
- Install the fuel tank (see Fuel Tank Installation).

3-20 FUEL SYSTEM

Fuel Filter

Fuel Filter Inspection

- Refer to Fuel Filter Inspection in the Periodic Maintenance Chapter (2nd chapter).

Air Cleaner

Element Removal

○ Refer to Air Element Removal in the Periodic Maintenance Chapter (2nd chapter).

Element Installation

○ Refer to Air Element Installation in the Periodic Maintenance Chapter (2nd chapter).

Element Cleaning and Inspection

○ Refer to Air Element Cleaning and Inspection in the Periodic Maintenance Chapter (2nd chapter).

Cleaner Body Removal

- Move the holders [A].

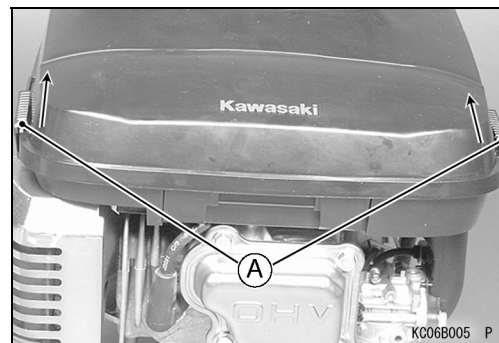

- Push up the latches [A] and remove the air cleaner case [B].
- Remove:
 - Paper Element
 - Foam Element

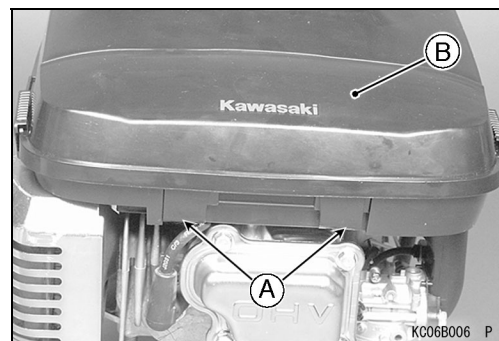

Cleaner Body Installation

- Install:
 - Foam Element
 - Paper Element
- Install the hollow [A] of the air cleaner case and projection [B] of the air cleaner body are fitting.

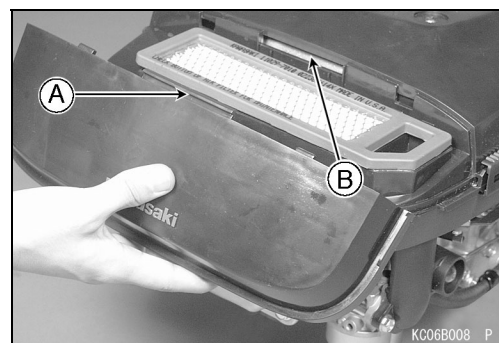

3-22 FUEL SYSTEM

Air Cleaner

- Move the holders [A].

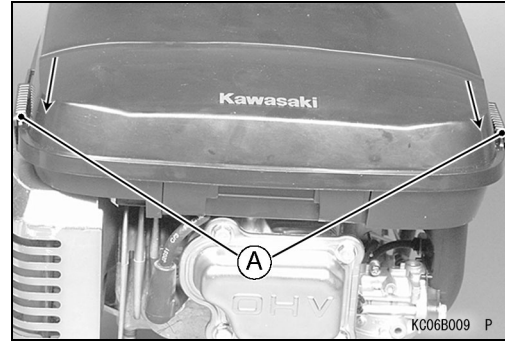

Housing (Case and Body) Inspection

- Refer to Air Cleaner Housing (Case and Body) Inspection in the Periodic Maintenance Chapter (2nd chapter).

Cooling System

TABLE OF CONTENTS

Exploded View	4- 2
Cooling Fan	4- 4
Cooling Fan Removal	4- 4
Cooling Fan Installation	4- 4
Cooling Fan Inspection	4- 4

4-2 COOLING SYSTEM

Exploded View

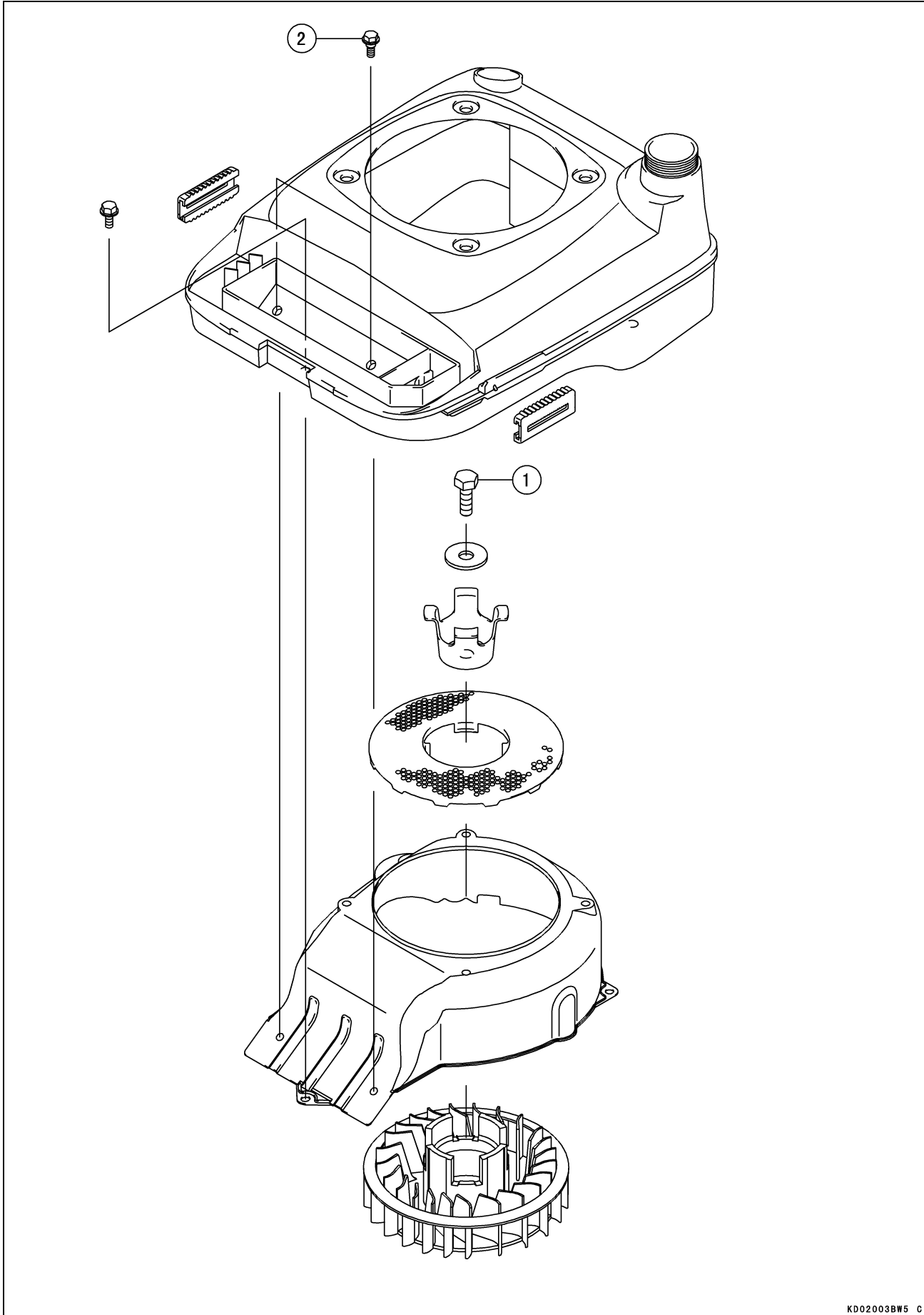

KD02003BW5 C

Exploded View

No.	Fastener	Torque			Remarks
		N·m	kgf·m	ft·lb	
1	Flywheel Bolt	42	4.3	31	
2	Fuel Tank Cover Bolts	6.9	0.70	61 in·lb	

4-4 COOLING SYSTEM

Cooling Fan

Cooling Fan Removal

○ Refer to Flywheel Removal in Electrical System Chapter.

Cooling Fan Installation

○ Refer to Flywheel Installation in Electrical System Chapter.

Cooling Fan Inspection

- Visually inspect the blades [A] in the cooling fan [B].
- ★ If there are any cracks, warps or damage, replace the cooling fan.
- ★ If any mud or dust has stuck to the cooling fan, clean it.
- Cooling fan is cleaned by washing in detergent and water.

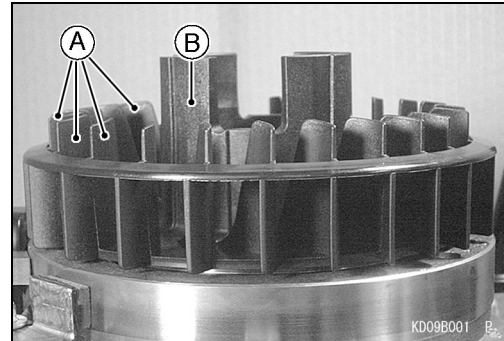

CAUTION

Do not clean the cooling fan in oil solvent. It may be damaged by oil solvent.

Engine Top End

TABLE OF CONTENTS

Exploded View	5- 2
Specifications	5- 4
Special Tools	5- 5
Cylinder Head	5- 6
Compression Measurement	5- 6
Cylinder Head Assembly Removal	5- 7
Cylinder Head Assembly Installation	5- 7
Push Rod Removal	5- 8
Push Rod Installation	5- 8
Push Rod Inspection	5- 8
Valve Mechanism Removal/Installation	5- 9
Cleaning and Inspection	5- 9
Rocker Arm Inspection	5-10
Valves	5-11
Valve Clearance Inspection	5-11
Valve Clearance Adjustment	5-11
Valve Seat Inspection	5-11
Valve Seat Repair	5-11
Valve Head Thickness	5-11
Valve Stem Runout	5-11
Valve Stem Diameter	5-11
Valve Guide Inside Diameter	5-12
Valve Spring Inspection	5-12
Automatic Compression Release (ACR) Device Inspection	5-12
Cylinder, Piston	5-13
Piston Removal	5-13
Piston Installation	5-14
Piston Cleaning	5-16
Piston Ring and Ring Groove Wear	5-17
Piston Ring End Gap	5-17
Piston Pin, Piston Pin Hole, and Connecting Rod Wear	5-18
Piston Diameter	5-18
Cylinder Inside Diameter	5-19
Muffler	5-20
Muffler Removal	5-20
Muffler Installation	5-20
Inspection	5-20

5-2 ENGINE TOP END

Exploded View

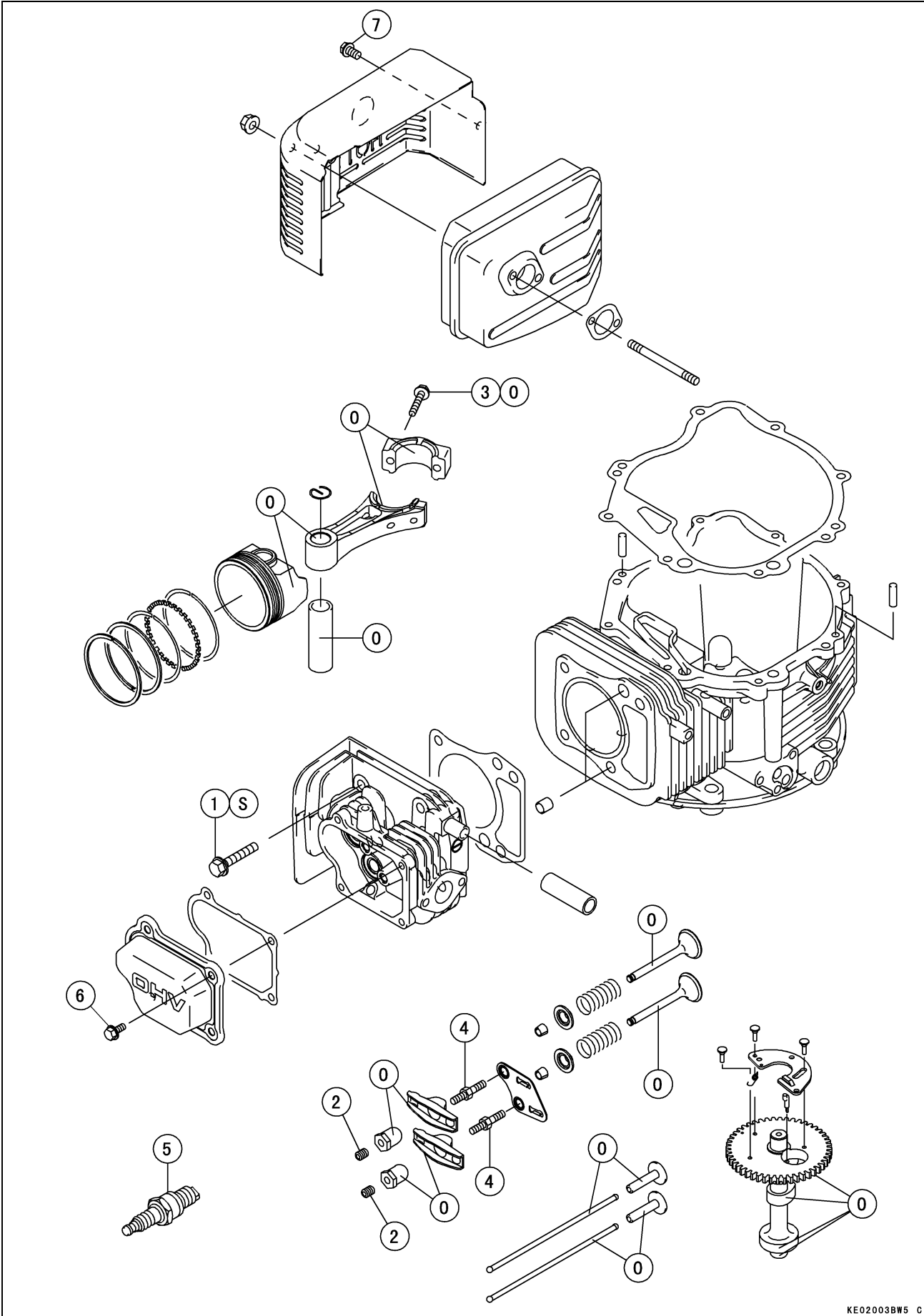

KE02003BW5 C

Exploded View

No.	Fastener	Torque			Remarks
		N·m	kgf·m	ft·lb	
1	Cylinder Head Bolts	22	2.2	16	S
2	Valve Clearance Lock Screws	6.9	0.70	61 in·lb	
3	Connecting Rod Big End Cap Bolts	5.9	0.60	52 in·lb	O
4	Rocker Arm Bolts	28	2.8	20	
5	Spark Plug	22	2.2	16	
6	Rocker Cover Mounting Bolts	5.9	0.60	52 in·lb	
7	Muffler Cover Self Tap Bolt (1)	6.9	0.70	61 in·lb	

O: Apply engine oil.

S: Follow the specific tightening sequence.

5-4 ENGINE TOP END

Specifications

Item		Service Limit
Cylinder Head:		
Cylinder compression (MIN)		[196 kPa (28.4 psi)] (MIN)
Cylinder head warp		0.03 mm (0.001 in.)
Valves:		
Valve head thickness	Intake	0.35 mm (0.014 in.)
	Exhaust	0.36 mm (0.014 in.)
Valve stem runout	Intake, Exhaust	0.05 mm (0.002 in.)
Valve stem diameter	Intake, Exhaust	5.93 mm (0.233 in.)
Valve guide inside diameter	Intake, Exhaust	6.08 mm (0.239 in.)
Valve spring free length	Intake, Exhaust	33.5 mm (1.32 in.)
Rocker arm push rod runout	Intake, Exhaust	0.5 mm (0.02 in.)
Exhaust valve lift height by ACR		0.9 mm (0.04 in.)
Cylinder, Piston		
Piston diameter		64.79 mm (2.551 in.)
Piston ring/groove clearance	Top, Second	0.17 mm (0.007 in.)
Piston ring thickness	Top, Second	1.40 mm (0.055 in.)
Piston ring end gap	Top, Second	0.75 mm (0.029 in.)
	Oil	1.05 mm (0.041 in.)
Piston pin outside diameter		15.96 mm (0.628 in.)
Piston pin hole inside diameter		16.08 mm (0.633 in.)
Connecting rod small end inside diameter		16.06 mm (0.632 in.)
Cylinder inside diameter	Standard Cylinder	65.10 mm (2.563 in.)
	0.50 mm Oversize	65.60 mm (2.583 in.)
Cylinder bore out round		0.056 mm (0.0022 in.)

Item		Standard
Valve clearance	Intake, Exhaust	0.10 ~ 0.15 mm (0.004 ~ 0.006 in.)
Valve seating surface angle	Intake, Exhaust	45°
Valve seating surface width	Intake, Exhaust	0.6 ~ 0.9 mm (0.024 ~ 0.035 in.)
Valves guide inside diameter	Intake, Exhaust	6.00 ~ 6.012 mm (0.2362 ~ 0.2367 in.)
Cylinder bore diameter standard cylinder		
Standard cylinder		64.98 ~ 65.00 mm (2.558 ~ 2.559 in.)
0.50 mm Oversize		65.48 ~ 65.50 mm (2.578 ~ 2.579 in.)

Special Tools

Compression Gauge: 57001-221

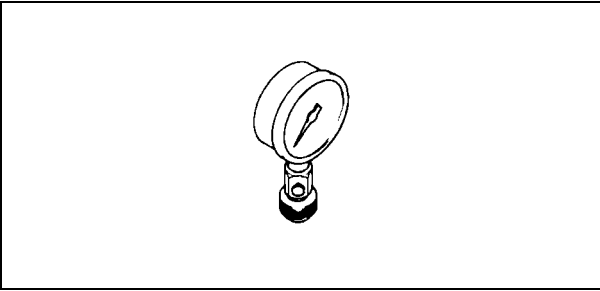

**Piston Ring Compression Belt, $\phi 55 \sim \phi 67$:
57001-1096**

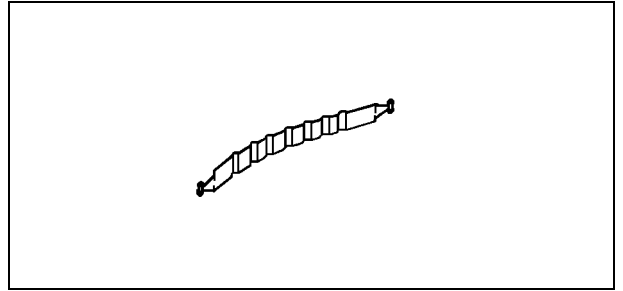

Piston Ring Compression: 57001-1095

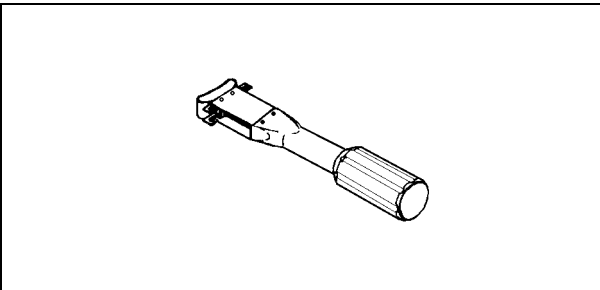

**Compression Gauge Adapter M14 \times 1.25 :
57001-1159**

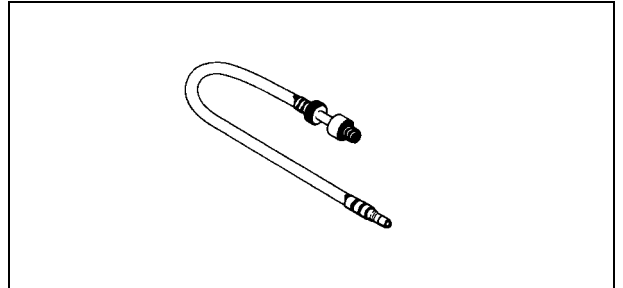

5-6 ENGINE TOP END

Cylinder Head

Compression Measurement

- Before measuring compression, do the following.
- Thoroughly warm up the engine so that engine oil between the piston and cylinder wall will help seal compression as it does during normal running.
- Stop the engine.
- Disconnect the spark plug cap and remove the spark plug.
- Attach the compression gauge assembly firmly into spark plug hole.

**Special Tools - Compression Gauge: 57001-221 [A]
Compression Gauge Adapter: 57001-1159 [B]**

- Ground the spark plug to the engine.

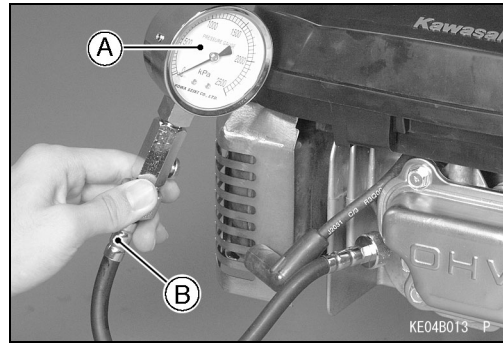

⚠ WARNING

To avoid fire, do not ground the spark plug in proximity to the plug hole. Keep the plug as far away as possible from the plug hole.

- With the throttle fully open, turn engine over with the recoil starter knob several times until the compression gauge stops rising, the compression is the highest reading obtainable.

Cylinder Compression (MIN) 196 kPa (28.4 psi)

- ★ If the compression is higher than the specified value, the piston rings, cylinder and valves are probably in good condition.
- ★ If the compression is too high, check the following:
 1. Carbon build-up on the piston crown and cylinder head - clean off any carbon on the piston crown and cylinder head.
 2. Cylinder head gasket - use only the proper gasket. The use of a gasket of incorrect thickness will change the compression.
 3. Valve guides and piston rings - rapid carbon accumulation in the combustion chamber may be caused by worn valve guides or worn piston oil ring. This may be indicated by white exhaust smoke.
- ★ If cylinder compression is lower than the (MIN), check the following:
 1. Gas leakage around the cylinder head - replace the damaged gasket and check and check the cylinder head warp.
 2. Condition of the valve seating.
 3. Valve clearance.
 4. Piston/cylinder wear, piston seizure.
 5. Piston ring, piston ring groove.

Cylinder Head

Cylinder Head Assembly Removal

- Remove:
 - Air Cleaner (see Fuel System chapter)
 - Recoil Starter (see Electrical System chapter)
 - Fuel Tank (see Fuel System chapter)
 - Muffler (see Muffler Removal)
 - Fan Housing (see Flywheel Removal)
 - Intake Manifold and Carburetor (see Fuel System chapter)
 - Spark Plug
- Loosen the rocker cover mounting bolts [A] and remove the cover [B] and gasket.
- When removing the cylinder head, set at T.D.C of Power stroke in.
- Loosen the cylinder head bolts 1/4 turn in the sequence shown.

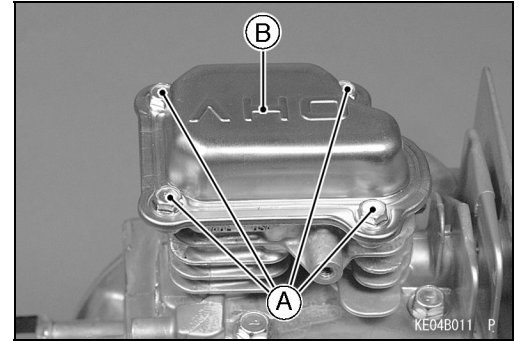

CAUTION

If the above procedure is not followed, the cylinder head may be warped during removal.

- Repeat the sequence until all bolts are removed and lift off the cylinder head assembly.

NOTE

- Mark the push-rods so they can be installed in their original position during assembly.

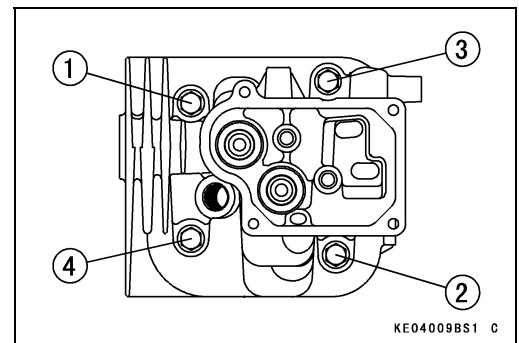

Cylinder Head Assembly Installation

- Clean the mating surfaces of the cylinder head and cylinder.
- Install the push rods in their original positions on cylinder (see Push Rod Installation).
- Install the knock pins.
- Set cylinder at T.D.C of power stroke in.
- Put new gasket and the cylinder head assembly on cylinder, then align the push rods under the rocker arms.
- Tighten the cylinder head bolts following the tightening sequence as shown.

Torque - Cylinder Head Bolts: 22 N·m (2.2 kgf·m, 16 ft·lb)

CAUTION

A torque wrench must be used to assure proper torque. Improper tightening of the head bolts can result in warping of the cylinder head.

- Check and adjust the valve clearance (see Periodic Maintenance chapter).
- Install the gasket and rocker cover.

Torque - Rocker Cover Mounting Bolts: 5.9 N·m (0.60 kgf·m, 52 in·lb)

- Install the other removed parts.

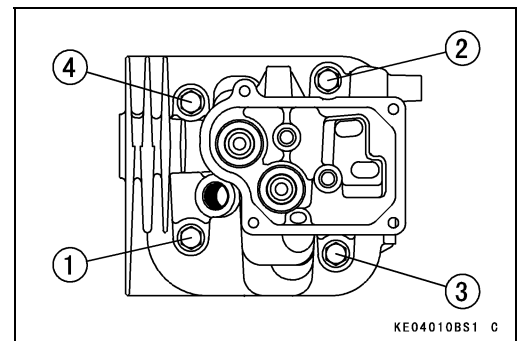

5-8 ENGINE TOP END

Cylinder Head

Push Rod Removal

- Set at T.D.C of power stroke in.
- Remove the rocker cover (see Cylinder Head Assembly Removal).
- Loosen the valve clearance adjusting nuts [A].
- Move the rocker arms [B] to clear the push rod upper ends.
- Pull out the push rods.

NOTE

- Mark the push rods so they can be installed in their original positions during assembly.

Push Rod Installation

- Set at T.D.C of power stroke in.
- Install the push rods [A] in their original positions on cylinder.
- To Install the push rod in the correct position on the tappet [B], insert the push rod so end of the push rod is sliding down along inside wall [C] of the crankcase and position the push rod end onto the tappet.
- Check that both intake and exhaust push rod on cylinder is at lowest position on the cam lobes [D], if not, turn the flywheel clockwise one turn (360°) and reset at T.D.C of power stroke in.
- Be sure the end of the push rods are correctly seated on the tappets.
- Tighten the valve clearance adjusting nuts (see Periodic Maintenance chapter).
- Check and adjust the valve clearance (see Periodic Maintenance chapter).

Push Rod Inspection

- Place the push rod in V blocks that are as far apart as possible, and set a dial gauge [A] on the rod at a point halfway between the blocks. Turn the rod to measure the runout. The difference between highest and the lowest dial readings is the amount of runout.
- ★ If the runout exceeds the service limit, replace the rod.

Rocker Arm Push Rod Runout

Service Limit: 0.5 mm (0.02 in.)

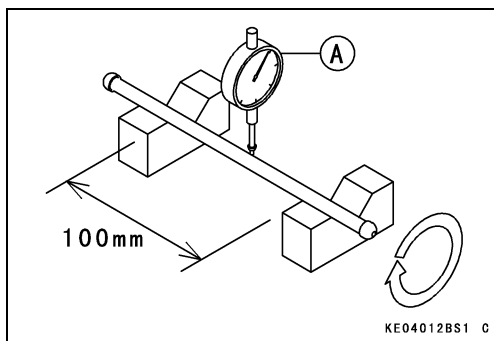
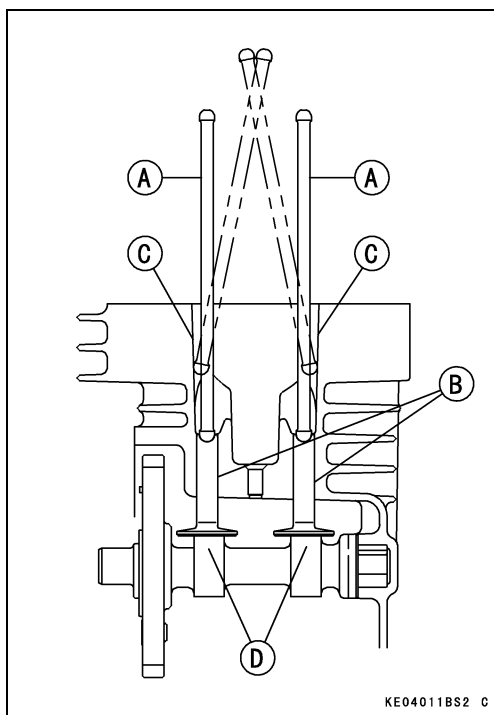
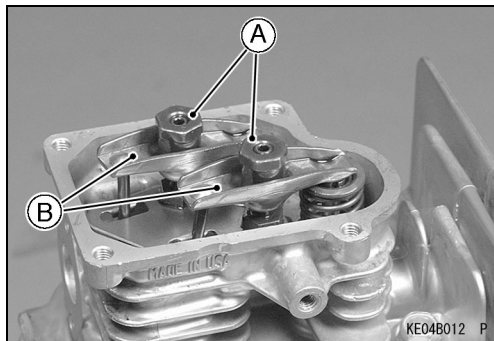

Cylinder Head

Valve Mechanism Removal/Installation

- Remove the cylinder head assembly (see Cylinder Head Assembly Removal).

NOTE

○ When removing the valve mechanism parts, note their position so that they may be reinstalled in their original position during assembly.

- Remove:
 - Valve Clearance Adjusting Nuts [A]
 - Rocker Arms [B]
- Support the valve head in the combustion chamber with a suitable block.
- To remove the collets [B], push down the valve retainer [A] with thumbs and remove the collets.
- Remove the spring [C] and valve [D] .

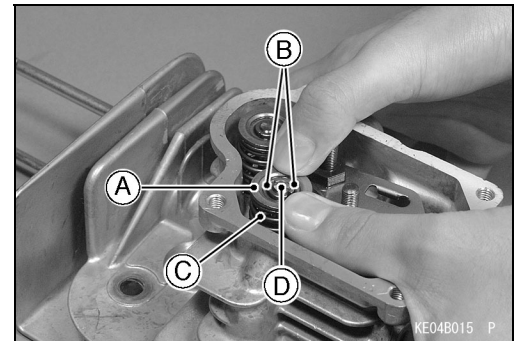
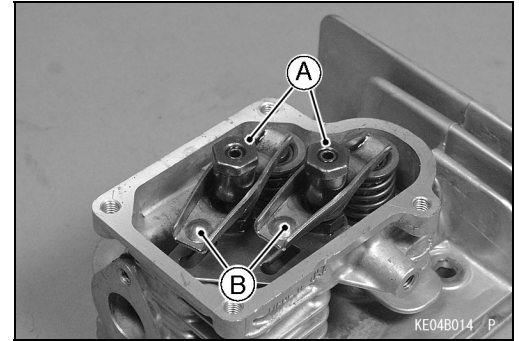

NOTE

○ Valve guide [A] is not replaceable, do not remove it.

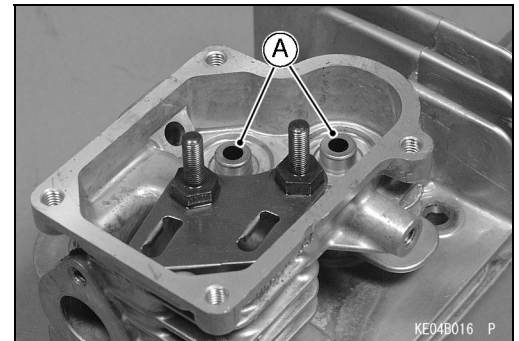

- Apply engine oil to the valve stem.
- Install the valve.
- Check to see that the valve moves smoothly up and down in the guide.
- Install the spring and valve retainer.
- To install the collets, push down the valve retainer with thumbs and install the collets.
- Soak the valve clearance adjusting nuts and rocker arms in the engine oil.
- Install the rocker arms by the valve clearance adjust screws.
- Adjust the valve clearance (see Periodic Maintenance chapter).

Cleaning and Inspection

- Refer to Cylinder Head Cleaning and Inspection in the Periodic Maintenance Chapter (2nd chapter).

5-10 ENGINE TOP END

Cylinder Head

Rocker Arm Inspection

- Clean and inspect the rocker arm where it touches the push rod and valve stem.
- ★ If the contact points [A] are worn or damaged, replace the rocker arm.

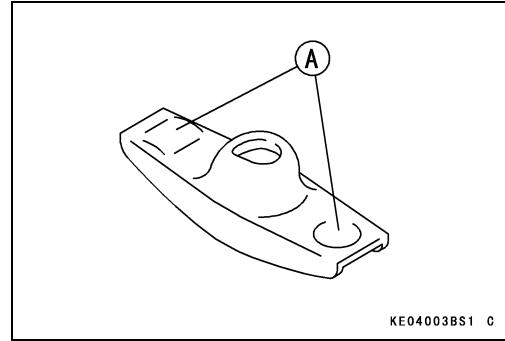

Valves

Valve Clearance Inspection

○ Refer to Valve Clearance Inspection in the Periodic Maintenance Chapter (2nd chapter).

Valve Clearance Adjustment

○ Refer to Valve Clearance Adjustment in the Periodic Maintenance Chapter (2nd chapter).

Valve Seat Inspection

○ Refer to Valve Seat Inspection in the Periodic Maintenance Chapter (2nd chapter).

Valve Seat Repair

○ Refer to Valve Seat Repair in the Periodic Maintenance Chapter (2nd chapter).

Valve Head Thickness

- Remove the valve (see Valve Mechanism Removal/Installation).
- Measure the thickness of the valve head.
- ★ If the valve head thickness (valve margin) [A] is less than the service limit, replace the valve.

Valve Head Thickness

Service Limit	IN:	0.35 mm (0.014 in.)
	EX:	0.36 mm (0.014 in.)

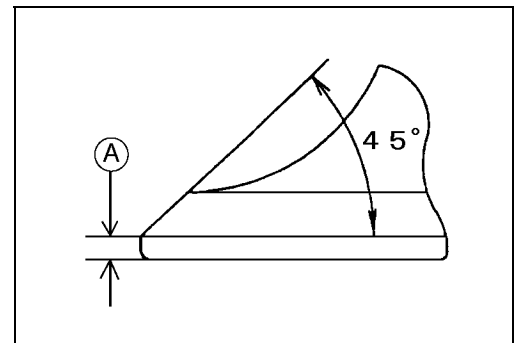

Valve Stem Runout

- Support the valve in V blocks at each end of the stem.
- Position a dial gauge perpendicular to the stem.
- Turn the valve and read the variation on the dial gauge.
- ★ If the stem runout is greater than service limit, replace the valve.

Valve Stem Runout

Service Limit (IN, EX):	0.05 mm (0.002 in.)
--------------------------------	----------------------------

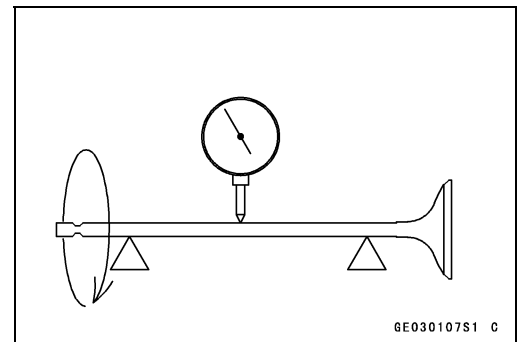

6E030107S1 C

Valve Stem Diameter

- Measure the diameter of the valve stem [A] in two directions at right angles, at four different positions on the stem.
- ★ If any single measurement is less than the service limit, replace the valve.

Valve Stem Diameter

Service Limit (IN, EX):	5.93 mm (0.233 in.)
--------------------------------	----------------------------

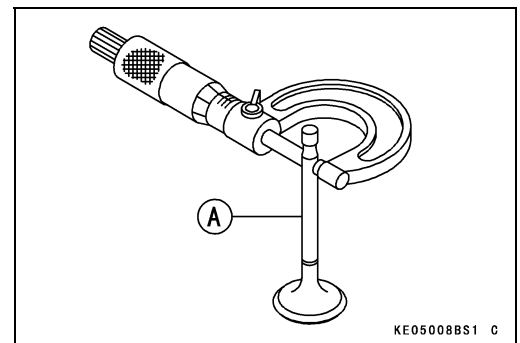

KE05008BS1 C

5-12 ENGINE TOP END

Valves

Valve Guide Inside Diameter

- Use a small bore gauge or a micrometer to measure the inside diameter [A] of the valve guides [B] at three places down the length of the guides.
- ★ If the measurement is more than the service limit, replace the cylinder head with a new one.

Valve Guide Inside Diameter

Service Limit (IN, EX) : 6.08 mm (0.239 in.)

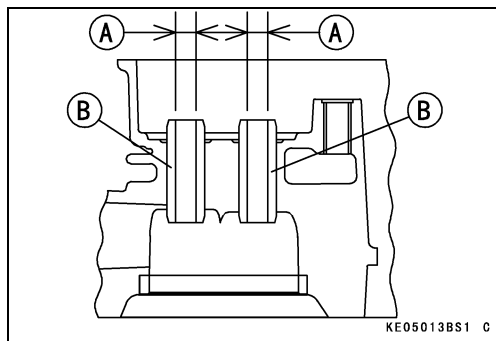

Valve Spring Inspection

- Inspect the valve spring for pitting, cracks, rusting, and burns. Replace the spring if necessary.
- Measure the free length [A] of the spring.
- ★ If the measurement is less than the service limit, replace the spring.

Valve Spring Free Length

Service Limit: 33.5 mm (1.32 in.)

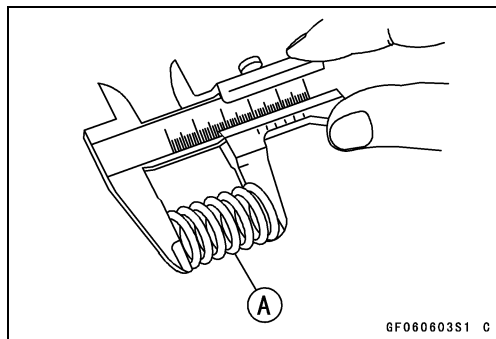

Automatic Compression Release (ACR) Device Inspection

The ACR reduces the compression of the cylinder in order to facilitate the revolution of the crankshaft during the starting of the engine.

- Remove:
 - Rocker Cover (see Cylinder Head Assembly Removal)
 - Spark Plug (see Electrical System chapter)
- Check whether the valves have the specified clearance (see Periodic Maintenance chapter).
- Slowly turn the crankshaft in the direction and observe the movement of the exhaust valve [A] and the rocker arm [B].
- ★ Immediately after the intake valve has closed, the rocker arm should push open the exhaust valve to attain a lift that is greater. If the exhaust valve does not lift to that height, the ACR that is provided on the camshaft is faulty (see Camshaft/Crankshaft chapter).

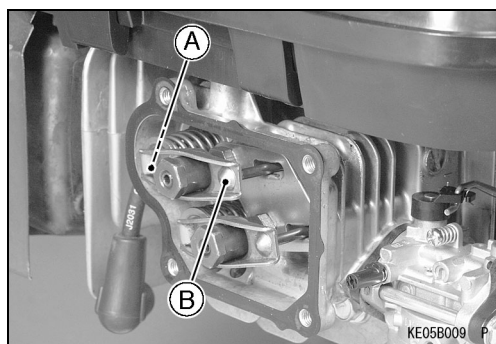

Exhaust Valve Lift Height Service Limit by ACR

Standard: 0.9 mm (0.04 in.)

Cylinder, Piston

Piston Removal

- Remove:
 - Air Cleaner (see Fuel System chapter)
 - Recoil Starter (see Electrical System chapter)
 - Fuel Tank (see Fuel System chapter)
 - Flywheel (see Electrical System chapter)
- Remove the crankcase cover (see Camshaft/Crankshaft chapter).
- Remove the camshaft (see Camshaft/Crankshaft chapter).
- Turn the crankshaft to expose the connecting rod cap bolts [A].
- Remove the bolts and take off the connecting rod cap [B].

NOTE

○ Note the position of the connecting rod cap for re-installing the cap.

- Push the connecting rod end into the cylinder, and pull the piston and connecting rod out of the cylinder.
- Remove one of the piston pin snap rings [A] with needle nose pliers [B].

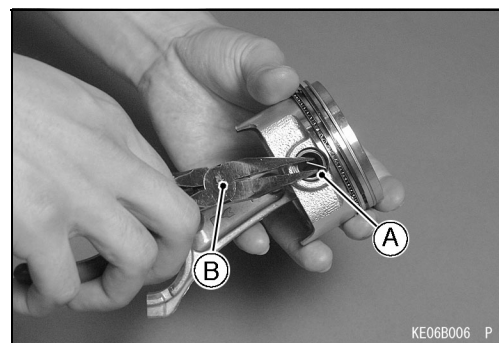
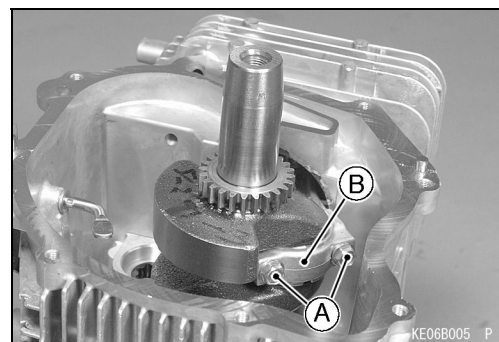

- Remove the piston by pushing the piston pin [A].



5-14 ENGINE TOP END

Cylinder, Piston

- Carefully spread the ring opening with your thumbs and then push up on the opposite side of the ring [A] to remove it.
- Remove the 3-piece oil ring with your thumbs in the same manner.

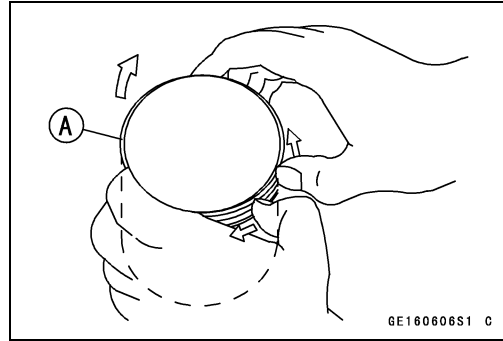

Piston Installation

- Install the expander [A] in the piston oil ring groove so that the expander ends [B] touch together, never overlap.
- Install the upper and lower steel rails. There is no UP or Down to the rails. They can be installed either way.

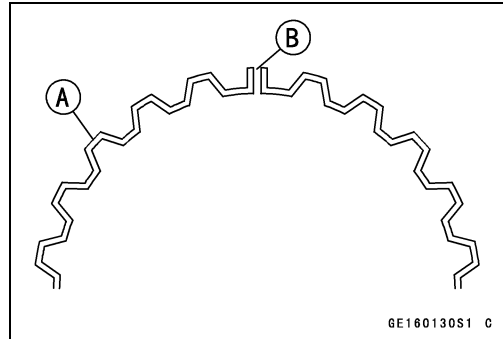

- Do not mix up the top and second ring.
- Install the second ring so that the "0" mark faces up.
- Install the top ring.
- The rings should turn freely in the grooves.

Piston Head [A]

Top Ring [B]

Second Ring [C]

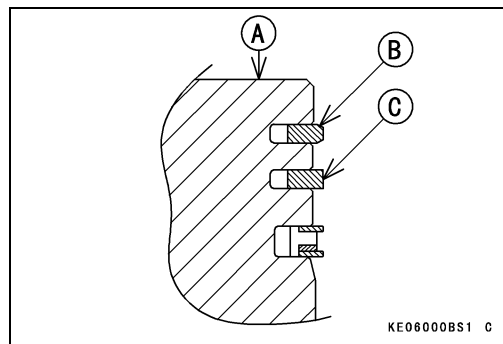

- Align the piston and rings with the piston ring end gap as shown.

Arrow Match Mark [A]

Top ring End Gap, Upper Steel Rail End Gap [B]

45° [C]

Second Ring End Gap, Lower Steel Rail End Gap [D]

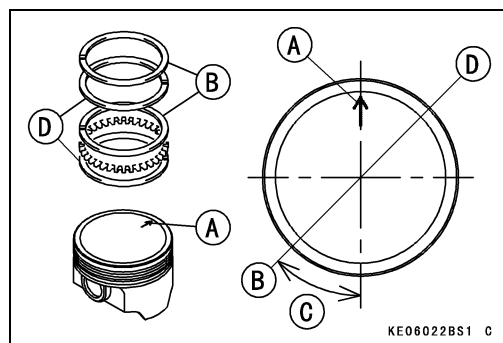

Cylinder, Piston

- Apply engine oil to the piston pin.
- Assemble the piston onto the connecting rod as follows: Set the arrow mark [A] on the piston head come reverse side of the "K" mark [B] side the connecting rod, then insert the piston pin into the piston pin hole.

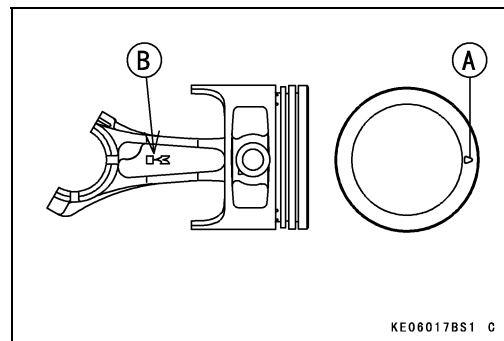

- Install the snap ring [A] in the piston [B] as shown.

CAUTION

Do not reuse the snap rings, as removal weakens and deforms them. They could fall out and score the cylinder wall.

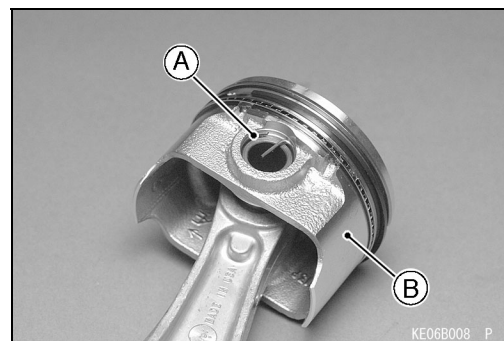

- Apply engine oil to the piston skirt and the cylinder bore.
- ★ Using the piston ring compressor grip [A] and the belt [B], lightly tap the top of the piston with a plastic mallet [C] to insert the piston and connecting rod into the cylinder.

**Special Tools - Piston Ring Compressor Grip: 57001-1095
Piston Ring Compressor Belt: 57001-1096**

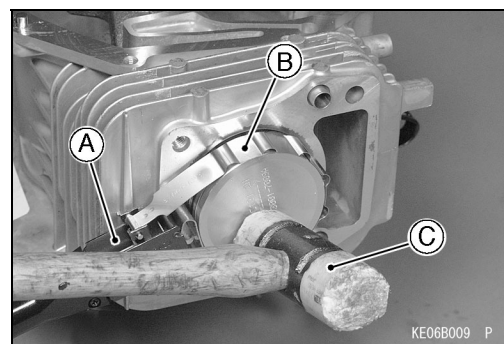

- Insert the piston and connecting rod so that the arrow mark [A] on the top of the piston is facing the flywheel side [B].

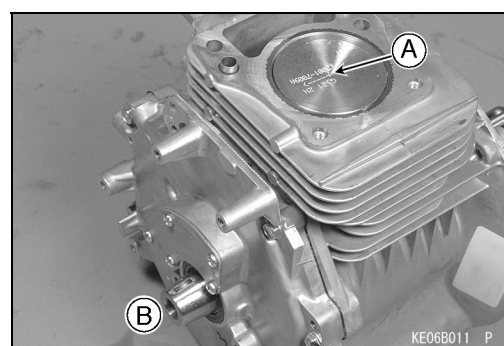

5-16 ENGINE TOP END

Cylinder, Piston

CAUTION

The connecting rod and the connecting rod big end cap are machined at the factory in the assembled state, so they must be replaced together as a set.

- Apply engine oil to the inner surface [A] of the connecting rod big end [B] and cap [C].
- Set rod and cap aligning the mark [D] of rod to the mark of cap, install the connecting rod big end cap in their original position on connecting rod big end.
- Apply a small amount of engine oil to the cap bolts [E].
- Tighten the cap bolts.

Torque - Connecting Rod Big End Cap Bolts: 5.9 N·m (0.60 kgf·m, 52 in·lb)

- Install:
 - Camshaft (see Camshaft/Crankshaft chapter)
 - Crankcase Cover (see Camshaft/Crankshaft chapter)
- Install the other removed parts.

Piston Cleaning

- Remove the piston and piston rings (see Piston Removal).

CAUTION

Never clean the piston head assembled. Carbon particles will fall between the piston and cylinder, and damage the piston and cylinder.

- Scrape the carbon off [A] the piston head.
- Use the scraping tools carefully. Do not gouge the piston head. To avoid gouging, use scrapers that are made of a material that will not cause damage.
- Clean the piston ring grooves [A] with a broken piston ring or other suitable tools.

CAUTION

Be careful not to widen the ring grooves. Damaged ring grooves will require piston replacement.

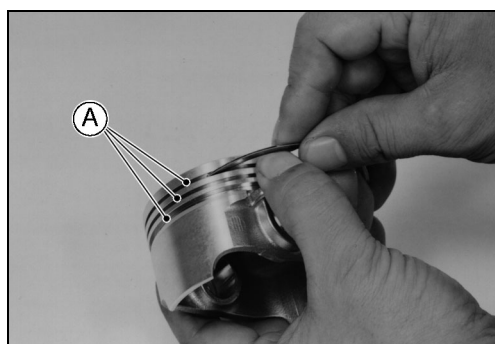
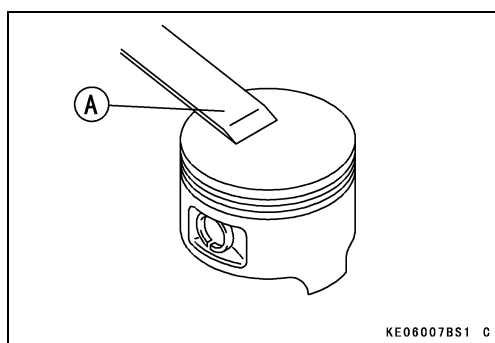
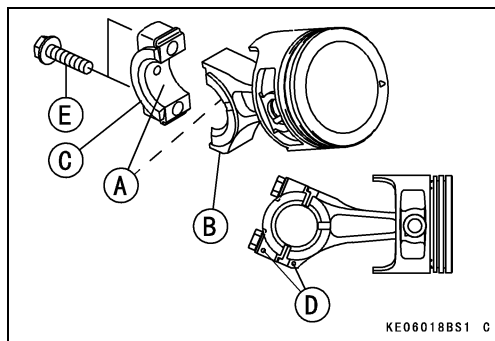

Cylinder, Piston

Piston Ring and Ring Groove Wear

- Clean the piston (see Piston Cleaning).
- Visually inspect the piston rings and ring grooves.
- ★ If the piston rings are worn unevenly or damaged, replace them.
- ★ If the ring grooves are worn unevenly or damaged, replace both the piston and piston rings.
- Measure the clearance between the top and second rings and their grooves using a thickness gauge [A].
- ★ If the piston ring/groove clearance is greater than the specified value, replace the piston.

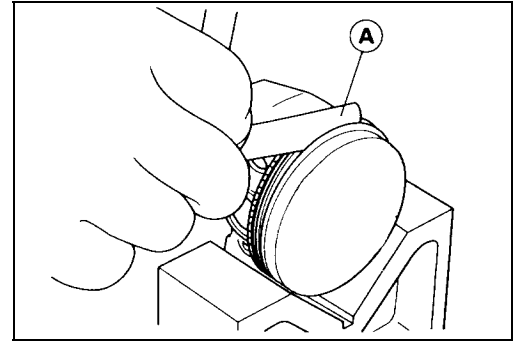

Piston Ring/Groove Clearance

	Service Limit
Top, Second	0.17 mm (0.007 in.)

NOTE

- The oil ring is a three piece assembled ring. It is difficult to measure the ring groove clearance and thickness, visually inspect only.

- Measure the piston ring thickness [A].
- Use a micrometer to measure at several points around the rings.
- ★ If any of the measurement are less than the service limit, replace the entire set of rings.

Piston Ring Thickness

	Service Limit
Top, Second	1.40 mm (0.055 in.)

NOTE

- When using new rings in a used piston, check for uneven groove wear. The rings should fit perfectly parallel to the groove sides. If not, replace the piston.

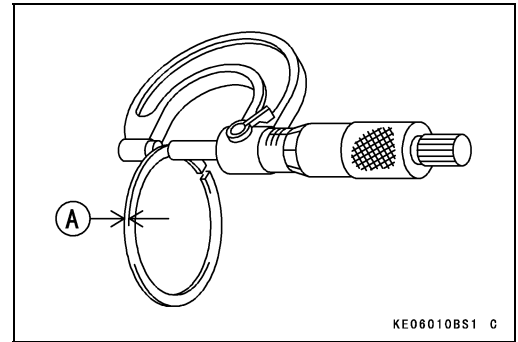

KE06010BS1 C

Piston Ring End Gap

- Remove the piston rings.
- Push each ring (one at a time) in the cylinder bore to a point close to the bottom of the cylinder bore.
- Use the piston to push it in to be sure it is square.
- Measure the gap [A] between the ends of the ring [B] with a thickness gauge.
- ★ If the end gap of any ring is greater than the service limit, replace the entire set of rings.

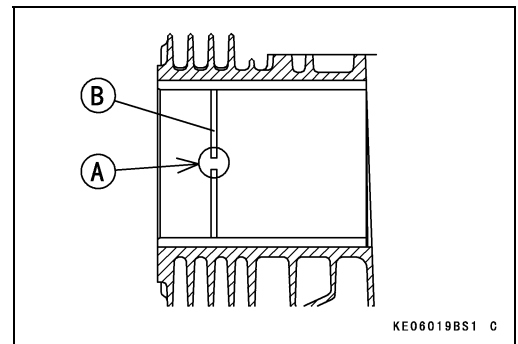

KE06019BS1 C

Piston Ring End Gap

	Service Limit
Top, Second	0.75 mm (0.029 in.)
Oil	1.05 mm (0.041 in.)

5-18 ENGINE TOP END

Cylinder, Piston

Piston Pin, Piston Pin Hole, and Connecting Rod Wear

- Remove the piston pin.
- Measure the diameter of the piston pin with a micrometer at several points.
- ★ If the outside diameter is less than service limit, replace the piston pin.

Piston Pin Outside Diameter

Service Limit: 15.96 mm (0.628 in.)

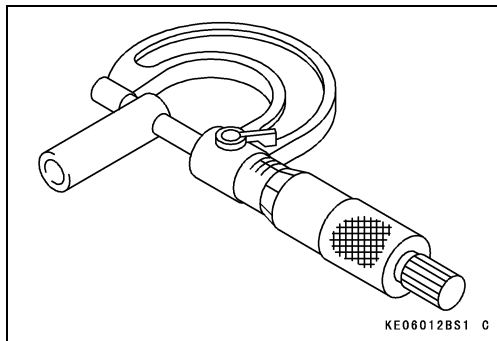

- Measure the inside diameter [A] of the piston pin hole at several points on both side. Use a dial bore gauge.
- ★ If the inside diameter is more than the service limit, replace the piston.

Piston Pin Hole Inside Diameter

Service Limit: 16.08 mm (0.633 in.)

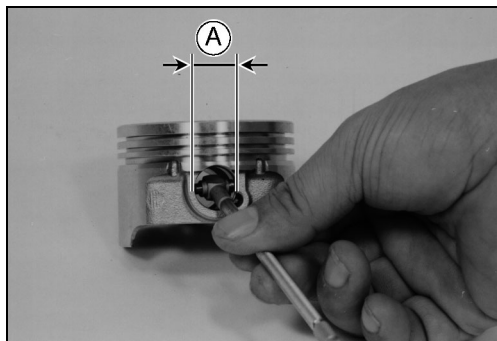

- Measure the inside diameter [A] of the small end of the connecting rod at several points. Use a dial bore gauge.
- ★ If the inside diameter is more than the service limit, replace the connecting rod.

Connecting Rod Small End Inside Diameter

Service Limit: 16.06 mm (0.632 in.)

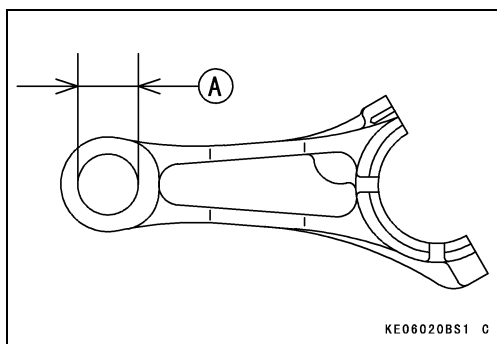

Piston Diameter

- Measure the outside diameter [A] of the piston 12.5 mm (0.9 in.) up [B] from the bottom of the piston at a right angle to the direction of the piston pin hole.
- ★ If the measurement is less than the service limit, replace the piston.

Piston Diameter

Service Limit: 64.79 mm (2.551 in.)

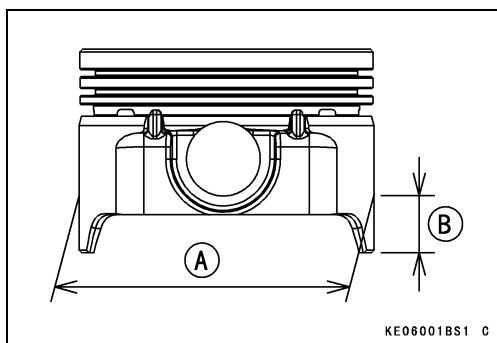

Cylinder, Piston

Cylinder Inside Diameter

- Clean and measure the cylinder inside diameter.
- Use a dial bore gauge to measure front-to-back and side-to-side at the points shown figure.
- ★ If any of the cylinder bore measurements is greater than the service limit, replace the cylinder with a new one.
 - 10 mm (0.39 in.) [A]
 - Middle [B]

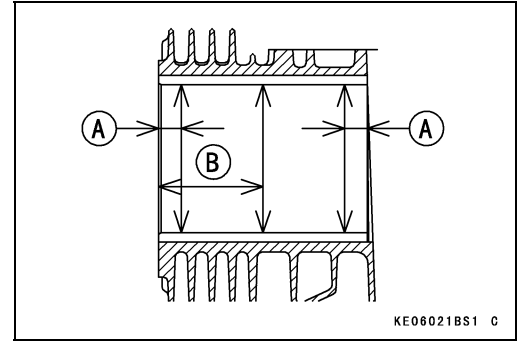

Cylinder Inside Diameter

Standard: 64.98 ~ 65.00 mm (2.558 ~ 2.559 in.)

Service Limit: 65.10 mm (2.563 in.)

Cylinder Bore Out-of-Round

Standard: 0.01 mm (0.0004 in.)

Service Limit: 0.056 mm (0.0022 in.)

5-20 ENGINE TOP END

Muffler

Muffler Removal

- Remove:
 - Muffler Cover Self Tap Bolt [C]
 - Muffler Cover Nuts [A]
 - Muffler Cover [B]
 - Muffler
- Remove the gasket.
- Do not use unnecessary force on the muffler when removing the muffler assembly, or they could become damaged or distorted.

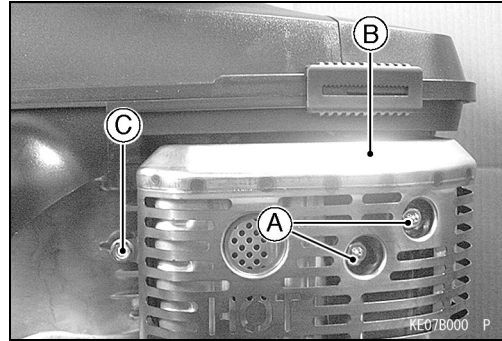

Muffler Installation

- Clean the gasket surface and install a new gasket each time the muffler is installed.
- Install the muffler.
- Install the muffler cover.
- Tighten the muffler cover nuts and self tap bolt.
 - **Torque - Muffler Cover Self Tap Bolt: 6.9 N·m (0.70 kgf·m, 61 in·lb)**
- After installation, thoroughly warm up the engine, wait until the engine cools down and retighten the nuts and bolt.

Inspection

- Inspect the muffler for dents, cracks, rust and holes.
- ★ If the muffler is damaged, it should be replaced for best performance and least noise.
- Check the muffler for distortion or loose internal components. Loss of power could develop if loose internal muffler components restrict exhaust flow.

Lubrication System

TABLE OF CONTENTS

Exploded View	6- 2
Engine Oil Flow Chart.....	6- 4
Specifications	6- 5
Engine Oil	6- 6
Oil Level Inspection.....	6- 6
Oil Change	6- 6
Lubrication System	6- 7
Oil Pump.....	6- 8
Oil Pump Removal.....	6- 8
Oil Pump Installation.....	6- 8
Oil Pump Inspection.....	6- 8

6-2 LUBRICATION SYSTEM

Exploded View

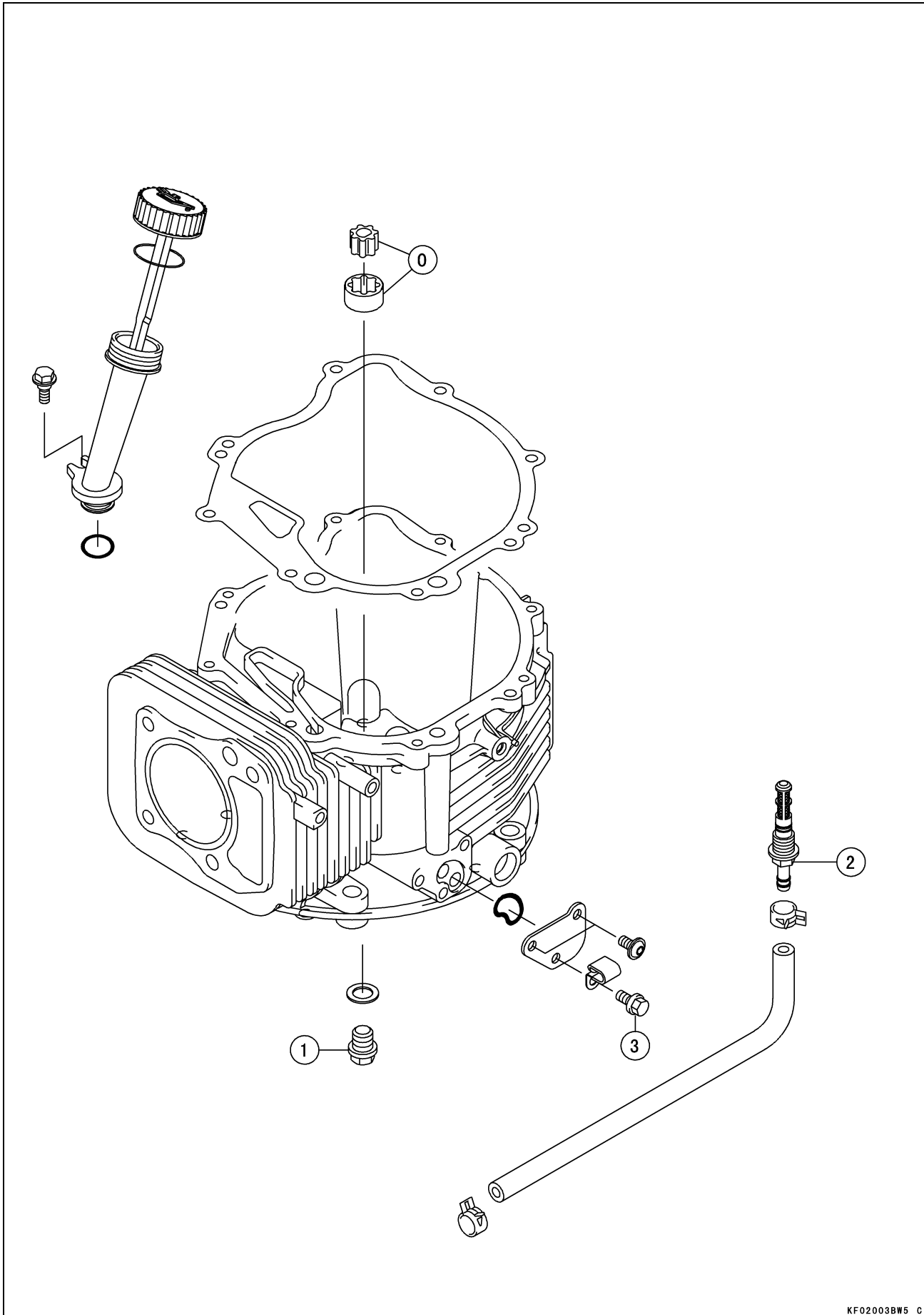

KF02003BW5 C

LUBRICATION SYSTEM 6-3

Exploded View

No.	Fastener	Torque			Remarks
		N·m	kgf·m	ft·lb	
1	Oil Drain Plug	22	2.2	16	
2	Tank Drain Bolt	6.9	0.70	61 in·lb	
3	Oil Filter Cover Bolt	6.9	0.70	61 in·lb	

O: Apply engine oil.

6-4 LUBRICATION SYSTEM

Engine Oil Flow Chart

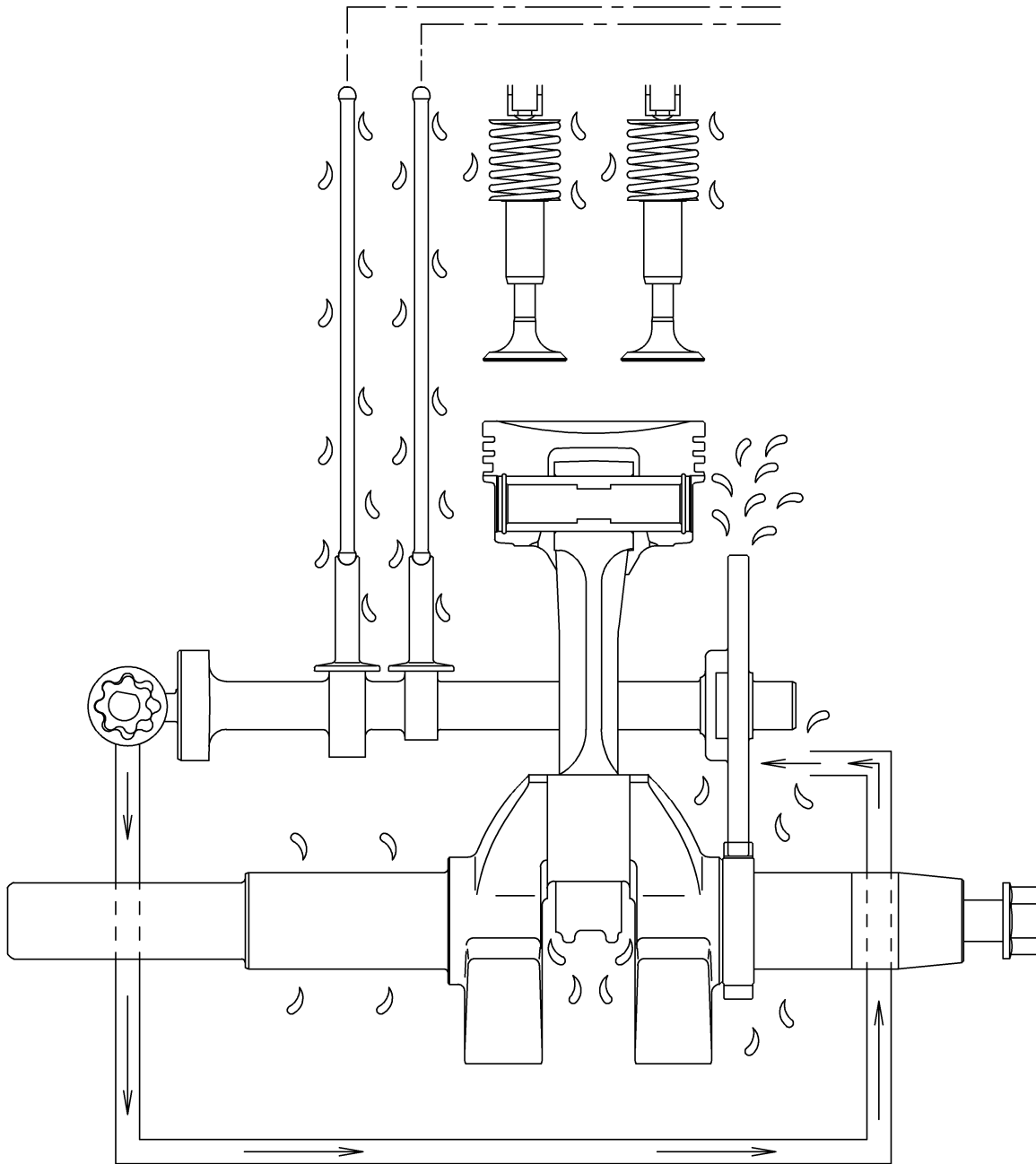

LUBRICATION SYSTEM 6-5

Specifications

Item	Standard
Engine Oil: Type Viscosity Capacity Level	SF, SG, SH or SJ class SAE30, SAE10W-30 [When engine is completely dry] 0.65 L (0.69 US-qt) Operating range (grid area) on dipstick

Item	Service Limit
Oil Pump: Inner and outer rotor clearance Outer rotor outside diameter Outer rotor thickness Pump housing inside diameter Pump housing depth	0.14 mm (0.006 in.) 22.940 mm (0.9031 in.) 11.960 mm (0.4709 in.) 23.241 mm (0.915 in.) 12.220 mm (0.4811 in.)

6-6 LUBRICATION SYSTEM

Engine Oil

CAUTION
<p>Engine operation with insufficient, deteriorated, or contaminated engine oil will cause accelerated wear and may result in engine seizure and accident. Before starting the engine for the first time, add oil: The engine is shipped dry. Preoil the engine to force all air from the internal oil passages.</p>

- Fill fresh engine oil to the specified level (see Periodic Maintenance chapter).
- Run the engine at slow speed 2 minutes.
- Stop the engine and check the oil level.

Oil Level Inspection

○ Refer to Oil Level Inspection in the Periodic Maintenance Chapter (2nd chapter).

Oil Change

○ Refer to Oil Change in the Periodic Maintenance Chapter (2nd chapter).

Lubrication System

Pressure the oil of oil pump is elevate the oil passages of crankcase of thread. Discharge the oil camshaft to side from crank ceiling side and the revolution of the camshaft to dissemination the oil mist from the crankshaft chamber. Lubrication the piston and big end, small end, shaft, gear.

6-8 LUBRICATION SYSTEM

Oil Pump

Oil Pump Removal

- Remove:
 - Air Cleaner (see Fuel System chapter)
 - Recoil Starter (see Electrical System chapter)
 - Fuel Tank (see Fuel System chapter)
 - Flywheel (see Electrical System chapter)
 - Crankcase Cover (see Camshaft/Crankshaft chapter)
 - Camshaft (see Camshaft/Crankshaft chapter)
 - Connecting Rod (see Camshaft/Crankshaft chapter)
 - Crankshaft (see Camshaft/Crankshaft chapter)
- Remove the oil pump assembly [A].

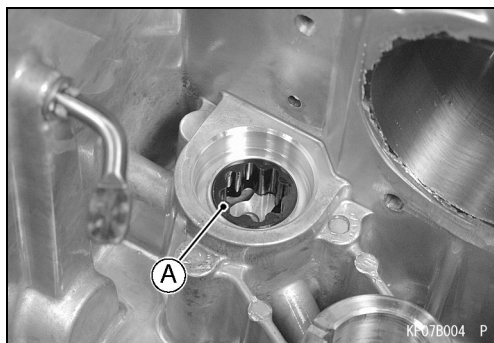

Oil Pump Installation

- Fill the rotor housing with engine oil for initial lubrication.
- Install the pump assembly [A] in the crankcase.
- Install the other removed parts.

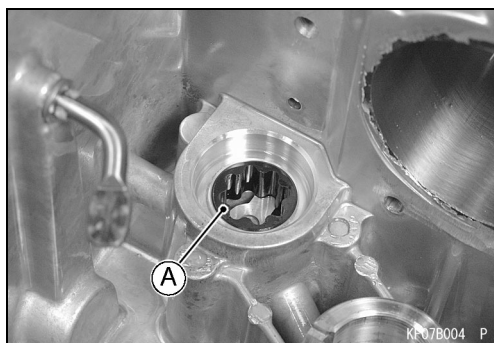

Oil Pump Inspection

- Remove the oil pump (see Oil Pump Removal).
- Visually inspect the outer and inner rotor.
- ★ If there is any damage or uneven wear, replace them.
- Check the clearance [A] between the inner and outer rotor with a feeler gauge. Measure the clearance between the high point of the inner rotor and the high point of the outer rotor.
- ★ If the measurement exceed the service limit, replace the rotors as a set.

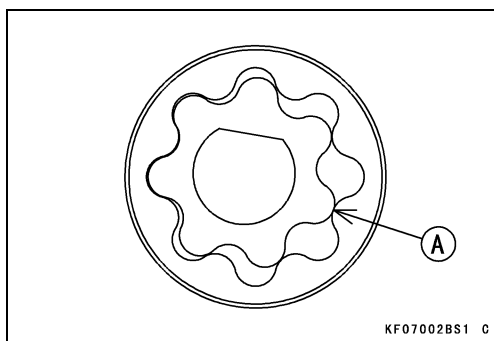

Inner and Outer Rotor Clearance

Service Limit: 0.14 mm (0.006 in.)

- Measure the outside diameter [A] of the outer rotor with a micrometer at several points.
- ★ If the rotor diameter is less than the service limit, replace both the inner and outer rotor.

Outer Rotor Outside Diameter

Service Limit: 22.940 mm(0.9031 in.)

- Measure the thickness [B] of the outer rotor with a micrometer at several points
- ★ If the rotor thickness is less than the service limit, replace both the inner and outer rotor.

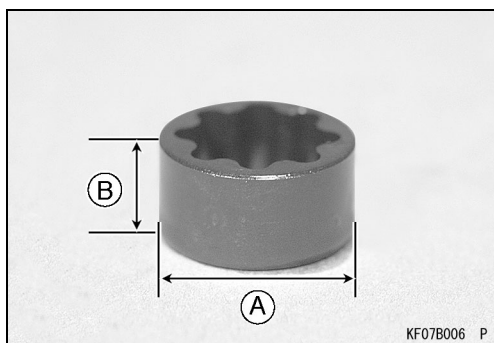

Outer Rotor Thickness

Service Limit: 11.960 mm (0.4709 in.)

Oil Pump

- Measure the inside diameter [A] of the pump housing with an inside micrometer at several points.
- ★ If the inside diameter is more than the service limit, replace the crankcase.

Pump Housing Inside Diameter

Service Limit: 23.241 mm (0.915 in.)

- Measure the depth [B] of the pump housing with a depth micrometer at several points.
- ★ If any of measurement is more than the service limit, replace the crankcase.

Pump Housing Depth

Service Limit: 12.220 mm (0.4811 in.)

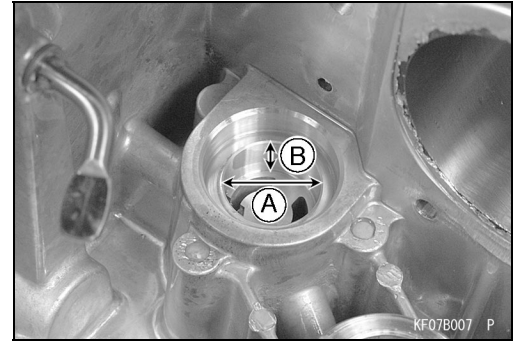

For Kawasaki Discount Parts Call 606-678-9623 or 606-561-4983

www.mymowerparts.com

Camshaft/Crankshaft

TABLE OF CONTENTS

Exploded View	7- 2
Specifications	7- 4
Crankcase	7- 5
Crankcase Cover Removal	7- 5
Crankcase Cover Installation	7- 5
Inspection.....	7- 6
Cleaning.....	7- 6
Breather	7- 7
Breather Chamber Cover Removal	7- 8
Breather Chamber Cover Installation	7- 8
Breather Valve Inspection	7- 8
Camshaft, Tappet	7- 9
Camshaft, Tappet Removal.....	7- 9
Camshaft, Tappet Installation.....	7-10
Camshaft Disassembly	7-10
Camshaft Assembly	7-10
Camshaft Inspection	7-10
Camshaft Bearing/Journal Wear	7-11
Crankshaft, Connecting Rod	7-12
Connecting Rod Removal	7-12
Connecting Rod Installation	7-12
Crankshaft Removal	7-12
Crankshaft Installation	7-12
Cleaning/Inspection	7-12
Connecting Rod Bend/Twist.....	7-13
Connecting Rod Big End/Crankpin Width Wear	7-13
Connecting Rod Big End Bearing/Crankpin Wear	7-14
Crankshaft Runout.....	7-14
Crankshaft Main Journal/Wear	7-15

7-2 CAMSHAFT/CRANKSHAFT

Exploded View

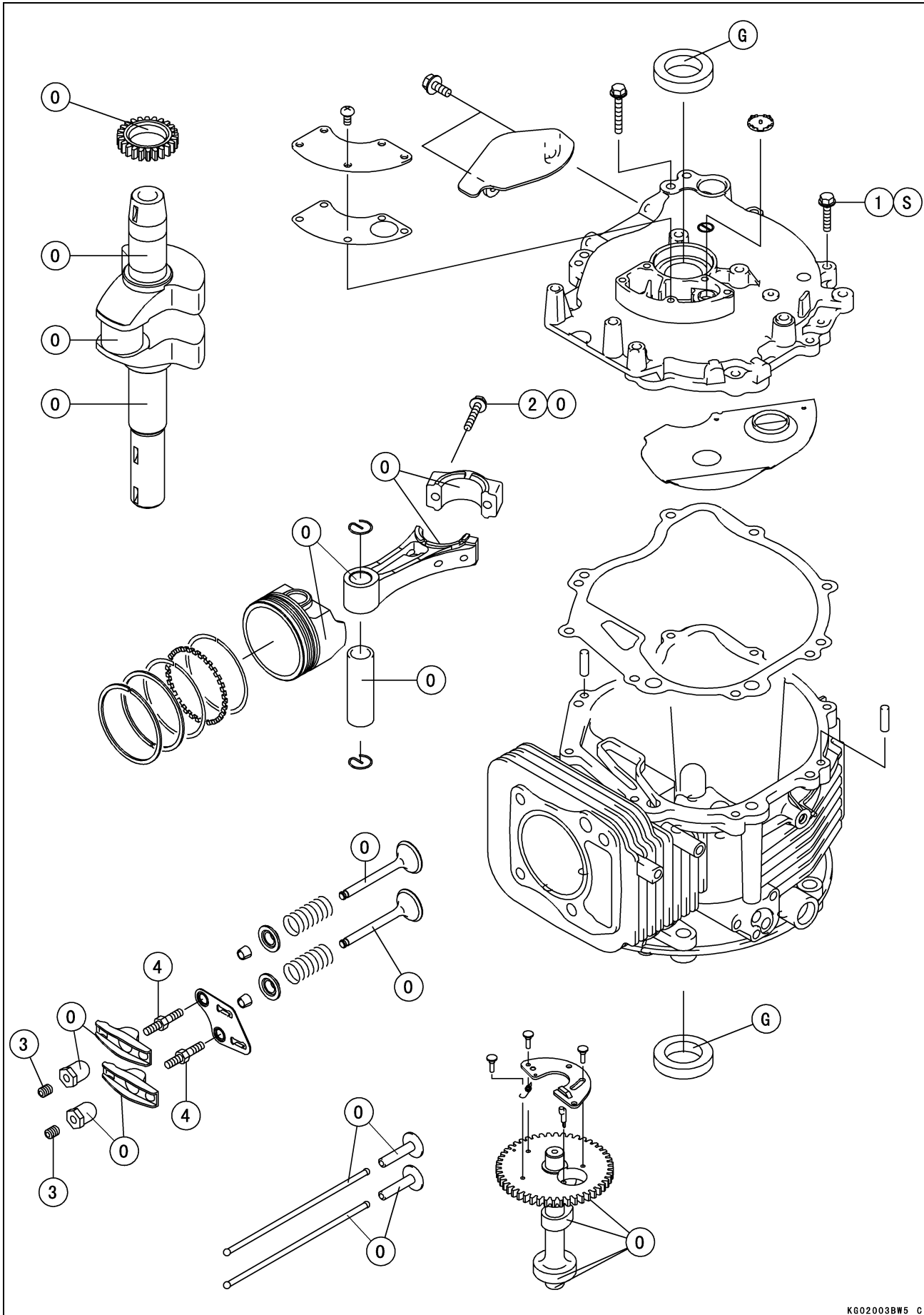

K602003BW5 C

Exploded View

No.	Fastener	Torque			Remarks
		N·m	kgf·m	ft·lb	
1	Crankcase Cover Bolts	8.8	0.90	78 in·lb	S
2	Connecting Rod Big End Cap Bolts	5.9	0.60	52 in·lb	O
3	Valve Clearance Lock Screws	6.9	0.70	61 in·lb	
4	Rocker Arm Bolts	28	2.8	20	

G: Apply grease.

O: Apply engine oil.

S: Follow the specific tightening sequence.

7-4 CAMSHAFT/CRANKSHAFT

Specifications

Item	Service Limit
Camshaft, Tappet:	
Cam lobe height	Intake, Exhaust 22.060 mm (0.8685 in.)
Camshaft journal diameter	PTO side 7.77 mm (0.3059 in.)
	Flywheel side 13.927 mm (0.5483 in.)
Camshaft hole inside diameter	Crankcase cover 11.060 mm (0.4354 in.)
Crankshaft, Connecting Rod:	
Connecting rod bend	0.2/100 mm (0.008/3.94 in.)
Connecting rod twist	0.2/100 mm (0.008/3.94 in.)
Connecting rod big end width	23.44 mm (0.92 in.)
Crankpin width	24.17 mm (0.95 in.)
Connecting rod big end inside diameter	31.040 mm (1.222 in.)
Crankpin outside diameter	30.97 mm (1.219 in.)
Crankshaft runout	0.05 mm (0.002 in.) TIR
Crankshaft journal diameter	PTO side 27.96 mm (1.101 in.)
	Flywheel side 27.98 mm (1.102 in.)
Crankcase:	
PTO shaft hole inside diameter	Crankcase cover 27.98 mm (1.102 in.)
	Crankshaft journal metal inside diameter Crankcase 27.98 mm (1.102 in.)

Crankcase

Crankcase Cover Removal

- Drain the oil (see Lubrication System chapter).
- Remove:
 - Air Cleaner (see Fuel System Chapter)
 - Recoil Starter (see Electrical System Chapter)
 - Fuel Tank (see Fuel System Chapter)
 - Flywheel (see Electrical System Chapter)
- Unscrew the mounting bolts [A] and remove the crankcase cover [B] from the crankcase.
- There are two knock pins on the crankcase mating surface. A wooden or plastic mallet may be used to gently tap loose the crankcase cover.

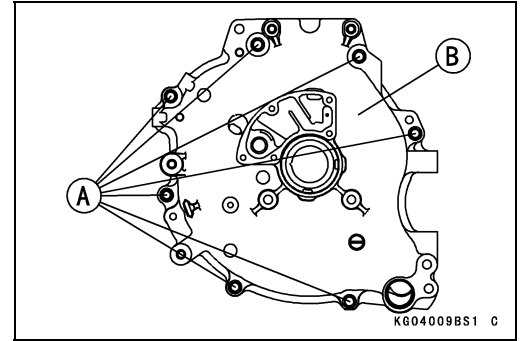

Crankcase Cover Installation

- Chip off the old gasket from the mating surfaces of the crankcase and cover.
- Using compressed air, blow out the oil passage in the crankcase cover.
- With a high flash-point solvent, clean off the mating surfaces of the crankcase and cover, and wipe dry.

⚠ WARNING

Clean the crankcase and cover in a well-ventilated area, and take care that there are no sparks or flame anywhere near the working area, this includes any appliance with a pilot light. Do not use gasoline or a low flash-point solvent to clean parts. A fire or explosion could result.

- Be sure to replace any oil seal removed with a new one.
- Install the oil seal so that the marks [A] face out.
- Thoroughly pack high temperature grease [B] into the space between the seal lip [C] and dust lip [D]. Press in the new oil seal using a press or suitable tools until it is flush with flange surface [E]. Do not damage the seal lips.

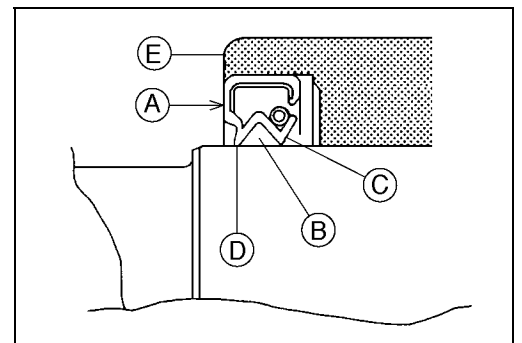

- Check to see that the dowel pins [A] are in place on the crankcase.
- Install the gasket on the crankcase.

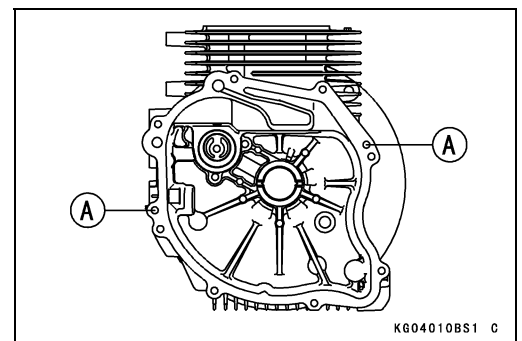

7-6 CAMSHAFT/CRANKSHAFT

Crankcase

- Install the crankcase cover and tighten the crankcase cover bolts following the tightening sequence shown.

Torque - Crankcase Cover Bolts: 8.8 N·m (0.90 kgf·m, 78 in·lb)

- Do not turn one bolt down completely before the others, as it may cause the crankcase cover to warp.

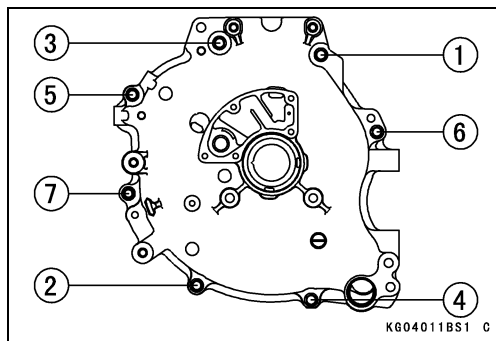

Inspection

- Measure the inside diameter [A] of the PTO shaft hole on the crankcase cover at several points. Replace the crankcase cover if the inside diameter is more than the service limit.

**PTO Shaft Hole Inside Diameter
Service Limit: 27.98 mm (1.102 in.)**

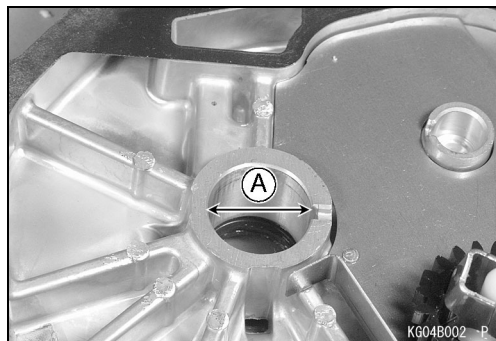

- Measure the inside diameter [A] of the crankshaft journal metal on the crankcase at several points. Replace the crankcase if the inside diameter is more than the service limit.

**Crankshaft Journal Metal Inside Diameter
Service Limit: 27.98 mm (1.102 in.)**

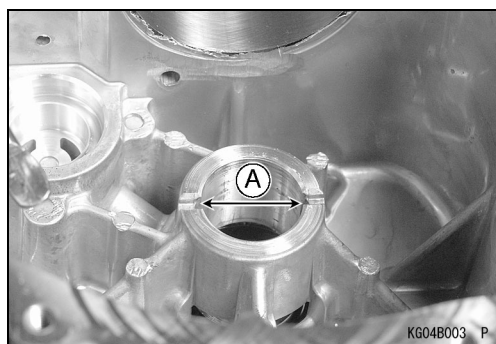

Cleaning

- Remove:
 - Camshaft and Tappets (see Camshaft, Tappet Removal)
 - Connecting Rod and Piston (see Engine Top End chapter)
 - Crankshaft (see Crankshaft Removal)
- Clean up the crankcase and cover with a high flash-point solvent, and blow out any foreign particles that may be in the pockets inside of the crankcase with compressed air.

⚠ WARNING

Clean the crankcase and cover in a well-ventilated area, and take care that there is no sparks or flame anywhere near the working area. Because of the danger of highly flammable liquids, do not use gasoline or low flash-point solvents.

Breather

The function of the breather is to create a negative pressure in the crankcase which prevents oil from being forced out of the engine through the piston rings, oil seals or gaskets. Valve controls direction of air flow caused by piston movement so that air flow from inside to outside can pass reed valve but not from outside to inside. Blow-by gas in crankcase passes through valve and expands in valve chamber. The air passes through expands in breather chamber. Then air passes through maze in breather chamber and is vented to intake pipe, through breather pipe.

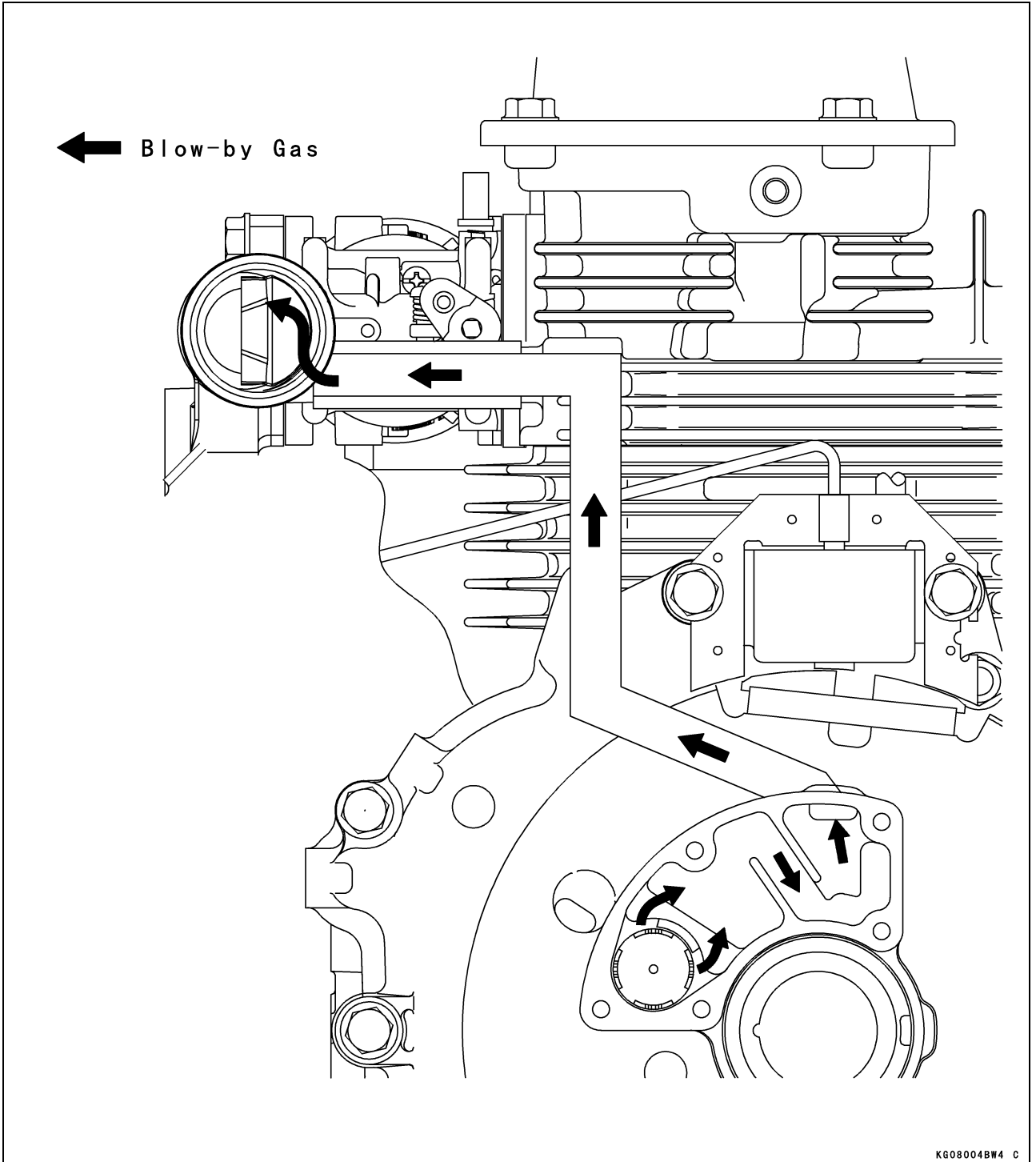

K608004BW4 C

7-8 CAMSHAFT/CRANKSHAFT

Breather

Breather Chamber Cover Removal

- Remove the bolts [A] and breather chamber cover [B].

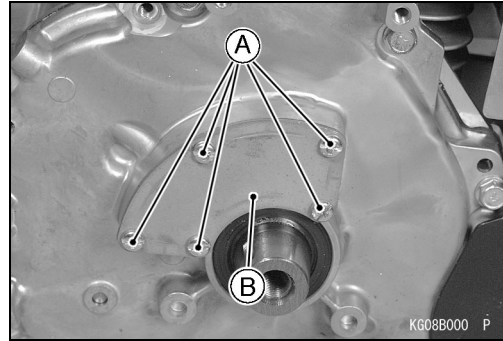

Breather Chamber Cover Installation

- Install a new gasket and the breather chamber cover, and tighten the bolts.

Breather Valve Inspection

- Remove the breather valve [A].
- Inspect the breather valve [A] for breakage, hair crack or distortion, replace it if necessary.
- Inspect the valve seating surface. The surface should be free of nicks or burrs.
- Be sure the drain hole on the breather chamber does not accumulate with slugs before installing the breather valve.

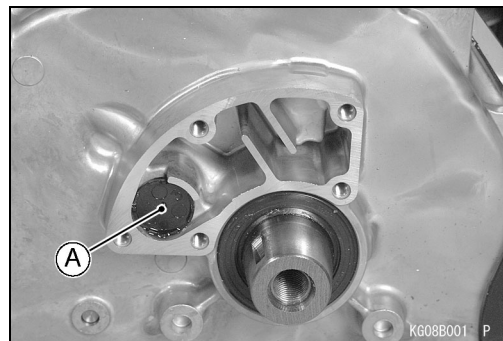

Camshaft, Tappet

Camshaft, Tappet Removal

- Drain the oil (see Lubrication System chapter).
- Remove:
 - Air Cleaner (see Fuel System chapter)
 - Recoil Starter (see Electrical System chapter)
 - Fuel Tank (see Fuel System chapter)
 - Flywheel (see Electrical System chapter)
 - Crankcase Cover (see Crankcase Cover Removal)
 - Rocker Cover [A]
- Position the piston TDC at the end of the compression stroke in.
- Push down [A] the spring side of the rocker arm [B] and move it to clear the push rod [C].
- Remove the push rods and mark them so they can be installed in their original positions during assembly.
- Place the crankcase with flywheel side toward top side.
- Pull the camshaft [A] out of the crankcase.
- Remove the tappets [A] and mark them so they can be installed in their original positions during assembly.

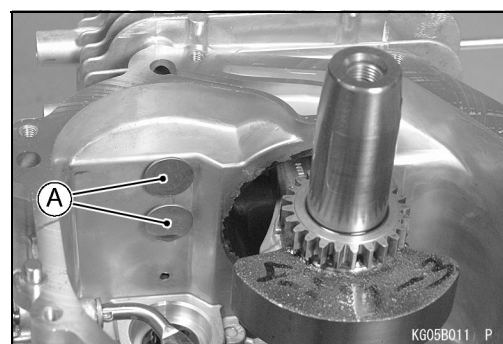
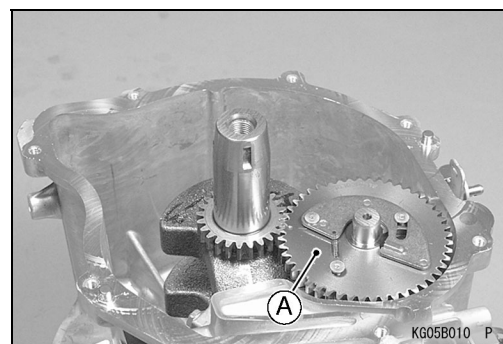
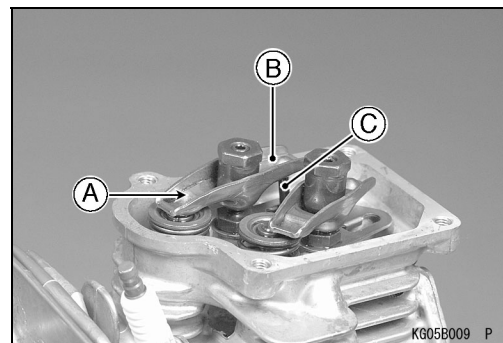
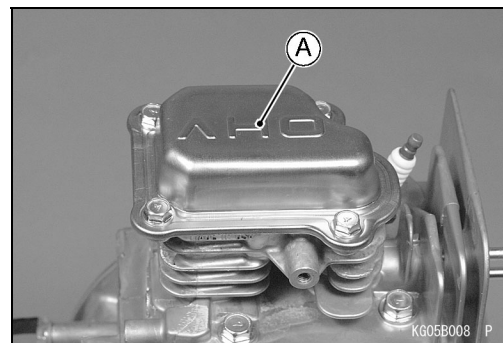

7-10 CAMSHAFT/CRANKSHAFT

Camshaft, Tappet

Camshaft, Tappet Installation

- Apply engine oil to the following.
 - Tappet Journal
 - Camshaft Journal
 - Cam Lobe Surface
 - Camshaft Gear
- Install the tappets in those old positions.
- Align the punch marks [A] on the crankshaft gear and on the camshaft gear.
- Install the push rods (see Push Rod Installation).
- Install the rocker arms on the push rods, and install the valve clearance adjust nuts.
- Adjust the valve clearance (see Engine Top End chapter).
- Install the gasket and rocker cover.
- Install the other removed parts.

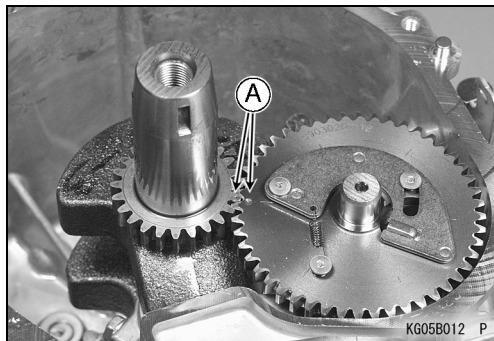

Camshaft Disassembly

- Remove the governor assembly (see Fuel System chapter).
- Remove:
 - Spring [A]
- Do not remove the ACR (automatic compression release) weight [B].

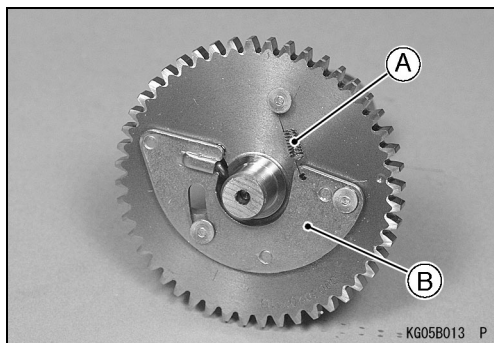

Camshaft Assembly

- Install the governor assembly (see Fuel System chapter).
- After assembling the camshaft, check the following items.
- While shaking the camshaft, ACR weight swings smoothly.

Camshaft Inspection

- Check the camshaft gear [A] for pitting, fatigue cracks, burrs or an evidence of improper tooth contact.
- ★ Replace the shaft if necessary.
- Check the top of the cam lobes [B] for wear, burrs or uneven contact.
- ★ Replace the shaft if necessary.

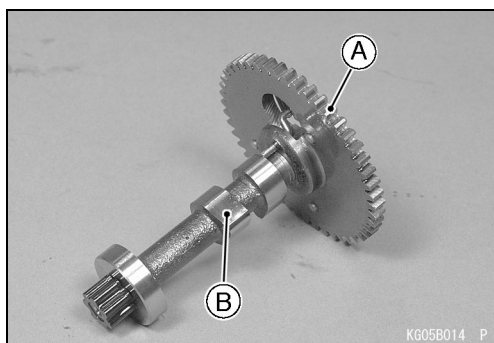

Camshaft, Tappet

- Inspect the camshaft to make sure that its automatic compression Reduction (ACR) function operates smoothly and does not have any damage or abnormal wear.
- ★ If ACR parts are worn, replace the ACR with a new one.
- ★ When the weight [A] is closed, if the top of the arm [B] is lower than the base [C], replace the ACR with a new one.
- ★ When the weight is pulled entirely outward with your finger, if the top of the arm is higher than the cam base, replace the ACR with a new one.

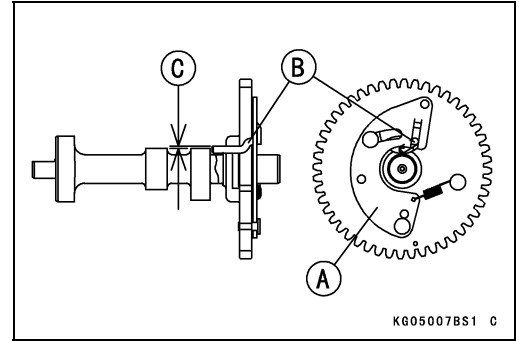

Camshaft Bearing/Journal Wear

- Measure the height [A] of each cam lobe.
- ★ If the cam height is less than the service limit for either lobe, replace the camshaft.

Cam Lobe Height

Service Limit (IN, EX) : 22.060 mm (0.8685 in.)

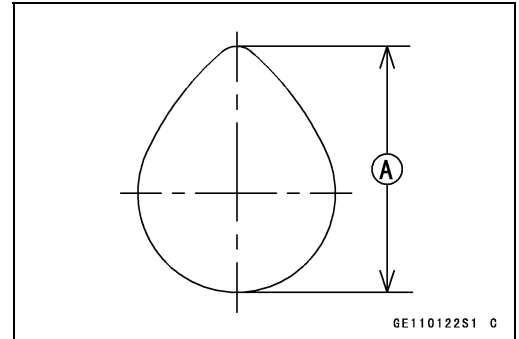

- Measure both camshaft journals at several points around the journal circumference.
- ★ If the journal diameter is less than the service limit, replace the camshaft.

PTO Side Camshaft Journal Diameter

Service Limit: 7.77 mm (0.3059 in.)

Flywheel Side Camshaft Journal Diameter

Service Limit: 13.927 mm (0.5483 in.)

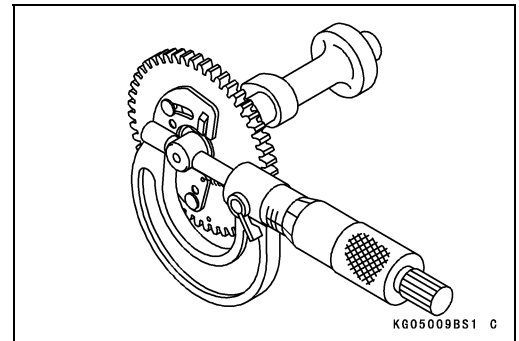

- Measure the inside diameter [A] of the camshaft hole on the crankcase cover at several points.
- ★ Replace the crankcase cover if the inside diameter is more than the service limit.

Camshaft Hole Inside Diameter (Crankcase Cover)

Service Limit: 11.060 mm (0.4354 in.)

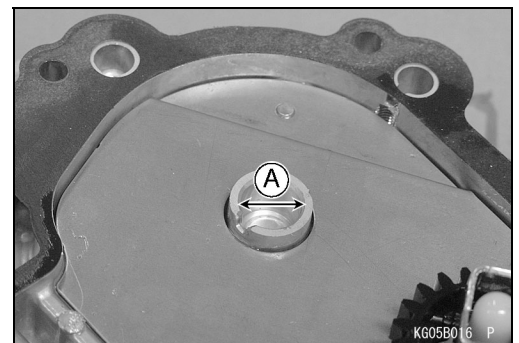

7-12 CAMSHAFT/CRANKSHAFT

Crankshaft, Connecting Rod

Connecting Rod Removal

- Remove:
 - Piston (see Engine Top End chapter)

Connecting Rod Installation

- Install:
 - Piston (see Engine Top End chapter)

Crankshaft Removal

- Drain the oil (see Lubrication System chapter).
- Remove:
 - Air Cleaner (see Fuel System chapter)
 - Recoil Starter (see Electrical System chapter)
 - Fuel Tank (see Fuel System chapter)
 - Flywheel (see Electrical System chapter)
 - Crankcase Cover (see Camshaft/Crankshaft chapter)
 - Camshaft (see Camshaft/Crankshaft chapter)
 - Connecting Rod (see Camshaft/Crankshaft chapter)
- Pull the crankshaft [A] out of the crankcase. Tap gently with a wooden or plastic mallet if necessary to loosen the crankshaft.

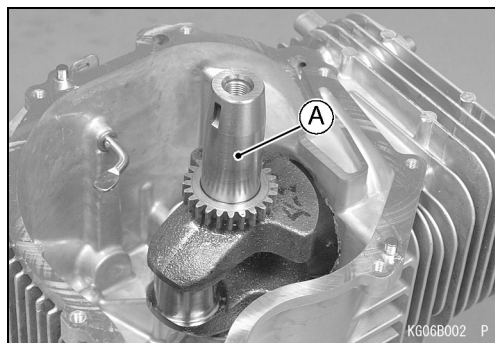

Crankshaft Installation

- Clean up the crankshaft and crankcase thoroughly.
- Check that the pivot arm for the governor is installed (see Fuel System chapter).
- Pack some amount of high temperature grease into the oil seal on the crankcase.
- Apply engine oil journal.
- Install the crankshaft in the crankcase.

Cleaning/Inspection

- After removing, clean the connecting rod and crankshaft with a high flash-point solvent and dry them with compressed air.
- Inspect the teeth of the crankshaft gear for pitting, fatigue cracks, burrs and evidence of improper tooth contact.
- ★ Replace the gear if necessary.
- Inspect the crankshaft and connecting rod for wear, scratches, evidence of improper contact or other damages.
- ★ Replace them if necessary.

Crankshaft, Connecting Rod

Connecting Rod Bend/Twist

- Measure connecting rod bend.
- Select an arbor of the same diameter as the connecting rod big end, and insert the arbor through the connecting rod big end.
- Select an arbor of the same diameter as the piston pin and at least 100 mm long, and insert the arbor through the connecting rod small end.
- On a surface plate, set the big-end arbor on V blocks [A].
- With the connecting rod held vertically, use a height gauge to measure the difference in the height of the small end arbor above the surface plate over a 100 mm length to determine the amount of connecting rod bend by dial gauge [B].
- ★ If connecting rod bend exceeds the service limit, the connecting rod must be replaced.

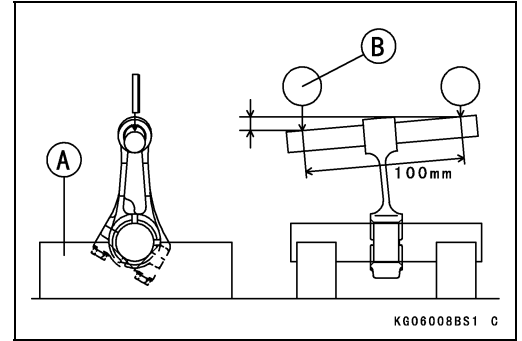

Connecting Rod Bend

Service Limit: 0.2/100 mm (0.008/3.94 in.)

- Measure connecting rod twist.
- With the big-end arbor still on the V blocks [A], hold the connecting rod horizontally and measure the amount that the small end arbor varies from being parallel with the surface plate over a 100 mm length of the arbor to determine the amount of connecting rod twist by dial gauge [B].
- ★ If connecting rod twist exceeds the service limit, the connecting rod must be replaced.

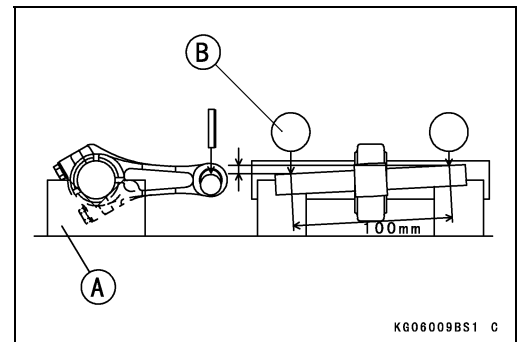

Connecting Rod Twist

Service Limit: 0.2/100 mm (0.008/3.94 in.)

Connecting Rod Big End/Crankpin Width Wear

- Measure the connecting rod big end width [A] with a micrometer or dial caliper.
- ★ If the measurement is less than the service limit, replace the connecting rod.

Connecting Rod Big End Width

Service Limit: 23.44 mm (0.92 in.)

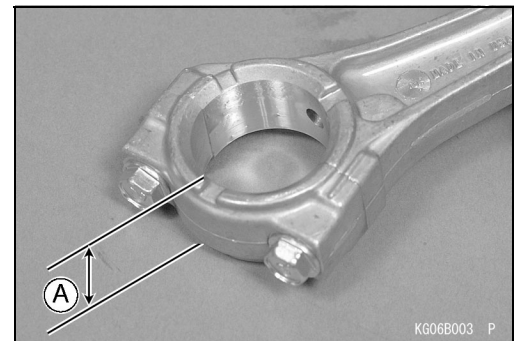

7-14 CAMSHAFT/CRANKSHAFT

Crankshaft, Connecting Rod

- Measure the crankpin width [A] with a dial caliper.
- ★ If the crankpin width is more than the service limit, replace the crankshaft.

Crankpin Width
Service Limit: 24.17 mm (0.95 in.)

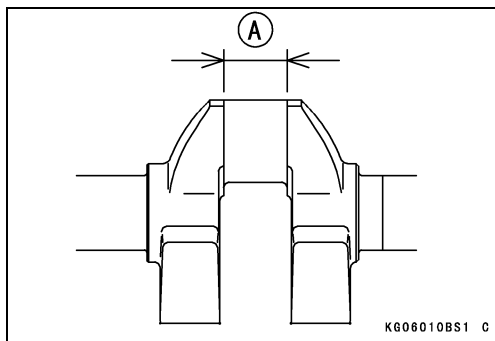

Connecting Rod Big End Bearing/Crankpin Wear

- Apply a light film of oil on the thread of the cap bolts.
- Install the cap bolts and tighten the bolts to the specified torque (see Piston Installation in Engine Top End chapter).
- Measure the inside diameter [A] of big end at several points with a telescoping gauge or inside micrometer.
- ★ If the inside diameter is more than the service limit, replace the connecting rod with a new one.

Connecting Rod Big End Inside Diameter
Service Limit: 31.040 mm (1.222 in.)

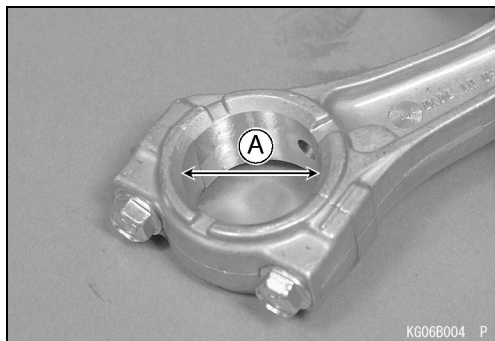

- Measure the crankpin outside diameter [A].
- Use a micrometer to measure several points around the crankpin circumference.
- ★ If the crankpin diameter is less than the service limit, replace the crankshaft with a new one.

Crankpin Outside Diameter
Service Limit: 30.97 mm (1.219 in.)

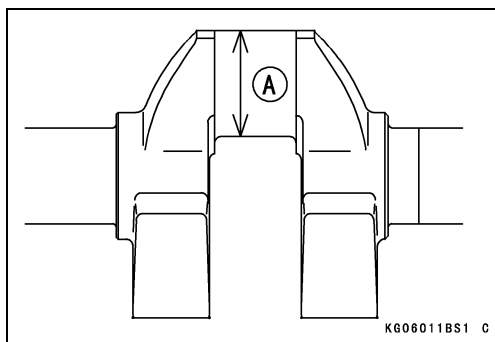

Crankshaft Runout

- Measure the crankshaft runout.
- Set the crankshaft in a flywheel alignment jig [A] or on V blocks gauge.
- Set a dial gauge [B] against both journals.
- Turn the crankshaft slowly to measure the runout. The difference between the highest and lowest dial gauge readings (TIR) is the amount of runout.
- ★ If the measurement exceeds the service limit, replace the crankshaft.

Crankshaft Runout
Service Limit: 0.05 mm (0.002 in.) TIR

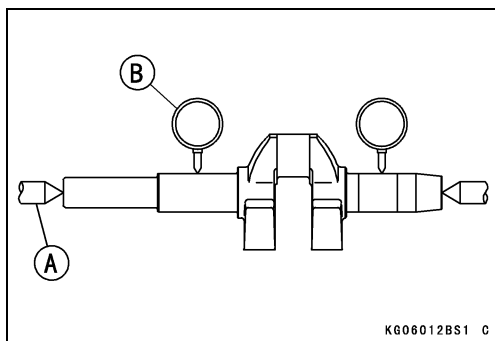

Crankshaft, Connecting Rod

Crankshaft Main Journal/Wear

- Measure both journals at several points around the journal circumference.
- ★ If the journal diameter is less than the service limit, replace the crankshaft with a new one.

PTO Side Crankshaft Journal Diameter [A]
Service Limit: 27.96 mm (1.101 in.)

Flywheel Side Crankshaft Journal Diameter [B]
Service Limit: 27.98 mm (1.102 in.)

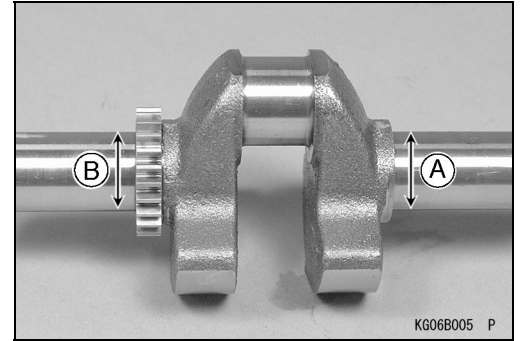

For Kawasaki Discount Parts Call 606-678-9623 or 606-561-4983

www.mymowerparts.com

Electrical System

TABLE OF CONTENTS

Exploded View	8- 2
Specifications	8- 4
Special Tools	8- 5
Wiring Diagram	8- 6
Precautions.....	8- 7
Charging, Ignition System	8- 8
Flywheel Removal.....	8- 8
Flywheel Installation.....	8- 9
Circuit Composition.....	8-11
Action Principle	8-11
Cautions of handling and maintenance.....	8-12
Ignition Coil Removal	8-12
Ignition Coil Installation	8-12
Ignition Coil Inspection.....	8-13
Spark Plug Removal	8-13
Spark Plug Installation	8-13
Spark Plug Cleaning and Inspection.....	8-13
Spark Plug Gap Inspection	8-13
Starter System.....	8-14
Recoil Starter Removal	8-14
Recoil Starter Installation	8-14
Recoil Starter Disassembly.....	8-14
Recoil Starter Assembly.....	8-15
Pad Brake.....	8-17
Pad Brake Assembly Removal	8-17
Pad Brake Assembly Installation	8-17
Brake Switch Removal/Installation.....	8-18

8-2 ELECTRICAL SYSTEM

Exploded View

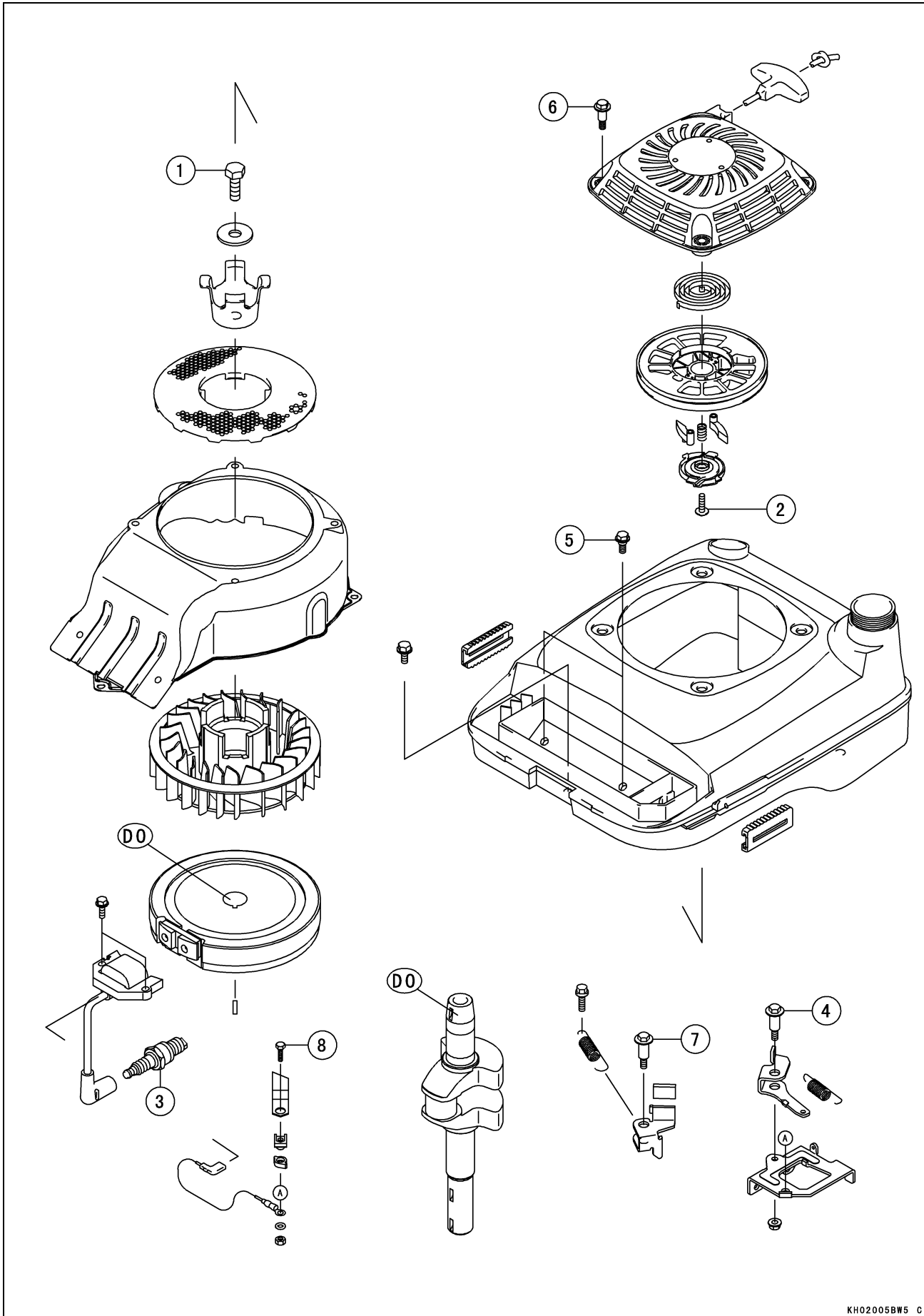

Exploded View

No.	Fastener	Torque			Remarks
		N·m	kgf·m	ft·lb	
1	Flywheel Bolt	42	4.3	31	
2	Recoil Starter Set Screw	1.0	0.10	8.9 in·lb	
3	Spark Plug	22	2.2	16	
4	Brake Arm Mounting Bolt	9.3	0.95	82 in·lb	
5	Fuel Tank Cover Bolts	6.9	0.70	61 in·lb	
6	Recoil Starter Mounting Bolts	6.9	0.70	61 in·lb	
7	Brake Lever Assembly Mounting Bolt	6.9	0.70	61 in·lb	
8	Kill Switch Bolt	1.5	0.15	13 in·lb	

DO: Degrease the taper.

8-4 ELECTRICAL SYSTEM

Specifications

Item	Standard	Service Limit
Ignition System:		
Ignition coil:		
Primary winding resistance	in the text	- - -
Secondary winding resistance	in the text	- - -
Spark Plug	NGK BPR5ES	- - -
Plug gap	0.75 mm (0.030 in.)	- - -

Special Tools

Hand Tester: 57001-1394

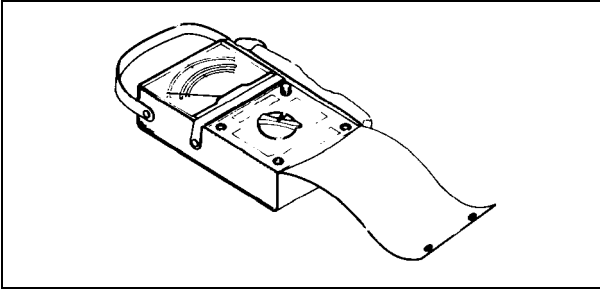

Bracket Holder: 57001-1536

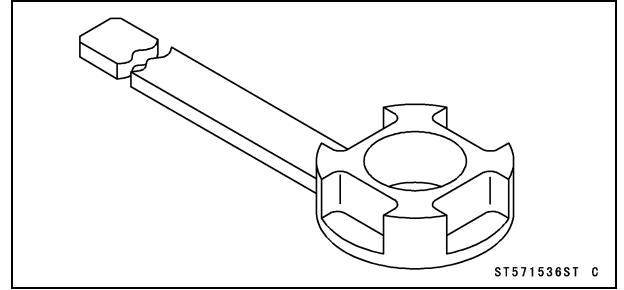

8-6 ELECTRICAL SYSTEM

Wiring Diagram

Note: Portion surrounded
by /// shows KHI
procurement parts

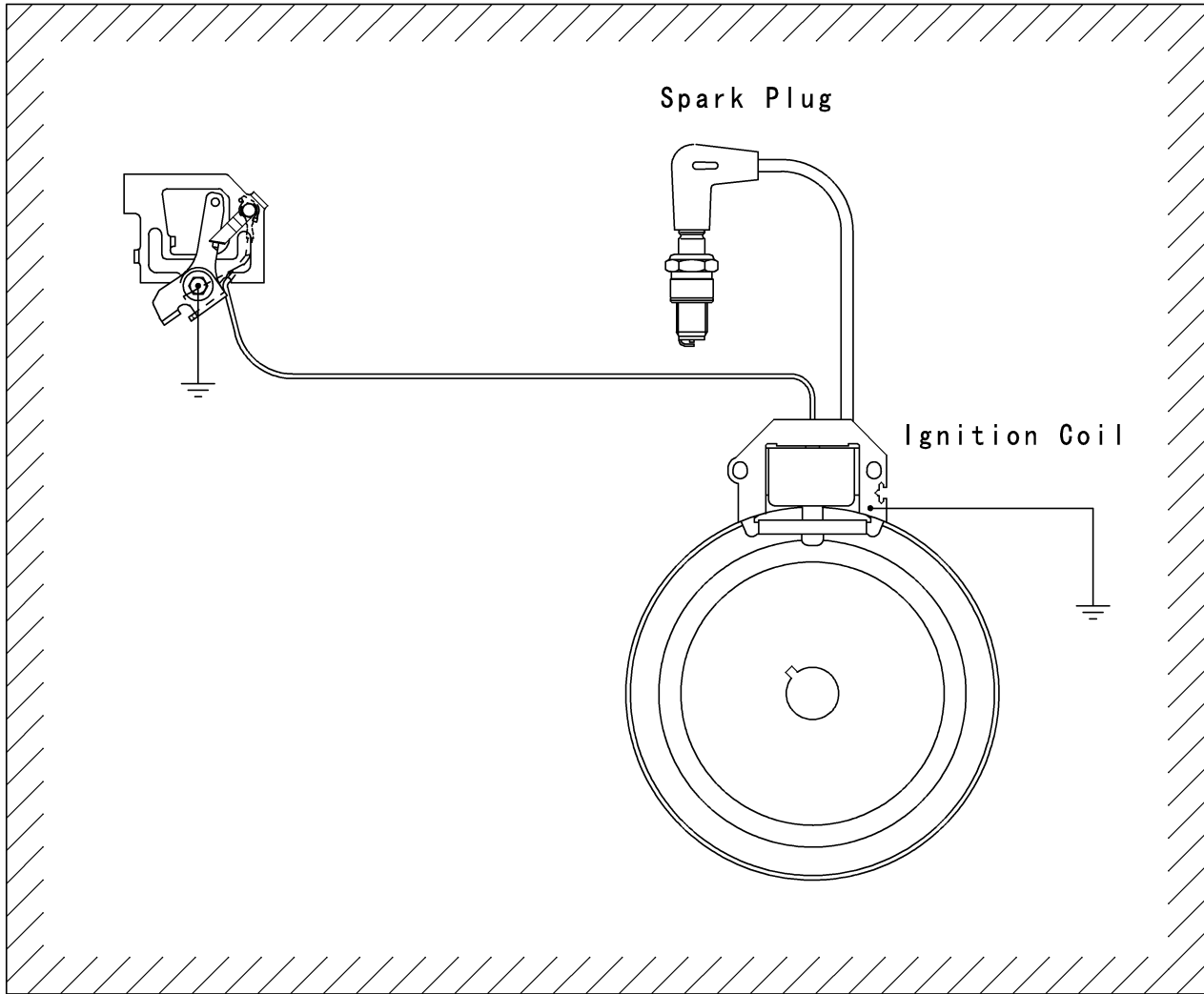

KH04010BW4 C

Precautions

There are a number of important precautions that must be taken when servicing electrical systems. Learn and observe all the rules below.

- The electrical parts should never be struck sharply, as with a hammer, or allowed to fall on a hard surface. Such a shock to the parts can damage them.
- Troubles may involve one or in some cases all items. Never replace a defective part without determining what CAUSED the failure. If the failure was brought on by some other item or items, they too must be repaired or replaced, or the replacement part will soon fail again.
- Make sure all connectors in the circuit are clean and tight, and examine wires for signs of burning, fraying, etc. Poor wires and bad connections will affect electrical system operation.
- Measure coil and winding resistance when the part is cold (at room temperature).
- Electrical Connectors:
 - Female Connector [A]
 - Male Connector [B]

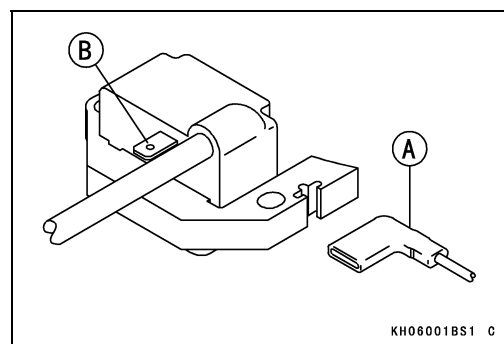

8-8 ELECTRICAL SYSTEM

Charging, Ignition System

Flywheel Removal

- Remove:
 - Air Cleaner (see Fuel System chapter)
 - Recoil Starter (see Electrical System chapter)
 - Fuel Tank (see Fuel System chapter)
- Hold the pulley [B] with a bracket holder [A], remove the flywheel bolt and washer.
- **Special Tool - Bracket Holder: 57001-1536**
- Remove the pulley.

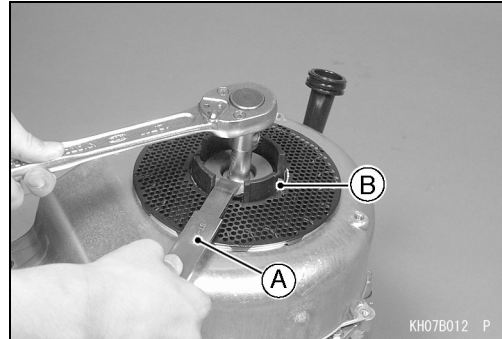

- Loosen the fan housing bolts [A] and remove the fan housing [B] and screen [C].
- Remove the fan.

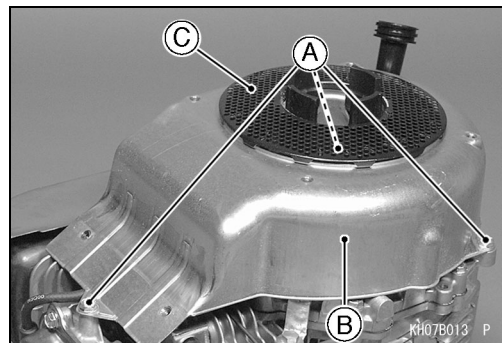

- Remove:
 - Ignition Coil (see Ignition Coil Removal)
- Remove the pad brake (see Pad Brake Removal).
- Using a suitable flywheel puller [A], remove the flywheel [B].

CAUTION

Always use flywheel puller.

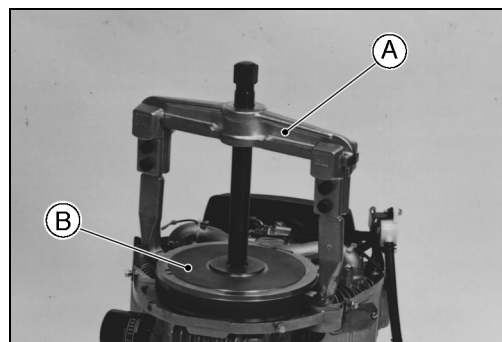

Charging, Ignition System

- Remove:
Woodruff Key [A]

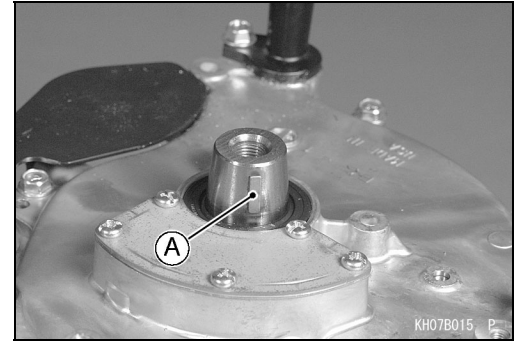

Flywheel Installation

- Using a cleaning fluid, clean off any oil or dirt on the following portions and dry them with a clean cloth.
Crankshaft Tapered Portion [A]
Flywheel Tapered Portion [B]
- Degrease the flywheel taper, crankshaft taper, before assembling.
- Fit the Woodruff key [C] securely in the slot in the crankshaft before installing the flywheel.
- Install the flywheel onto the crankshaft taper so that the woodruff key fits in the key way in the hub of the flywheel.

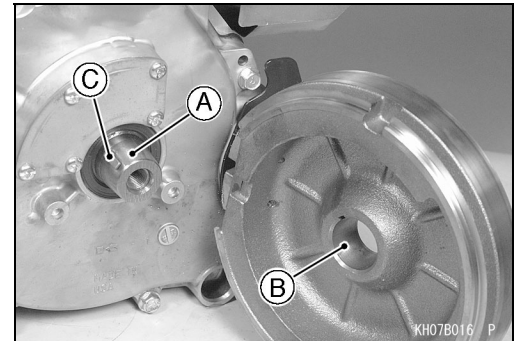

- Install:
Ignition Coil (see Ignition Coil Installation)
Pad Brake (see Pad Brake Installation)
- Install the fan [A] so that two positioning bosses [B] fit around flywheel ignition magnet [C].
- Install the fan housing and tighten the fan housing mounting screws.
- Install the screen to the fan housing.

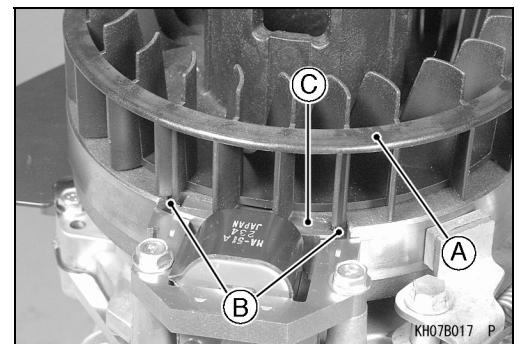

- The pulley [A] so that the project [B] fit into the recess [C] of the flywheel.

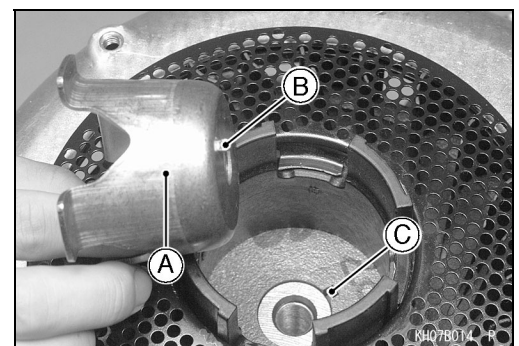

8-10 ELECTRICAL SYSTEM

Charging, Ignition System

- Install the pulley [A] and washer [B].
 - Tighten the flywheel bolt [C].
- Torque - Flywheel Bolt: 42 N·m (4.3 kgf·m, 31 ft·lb)**

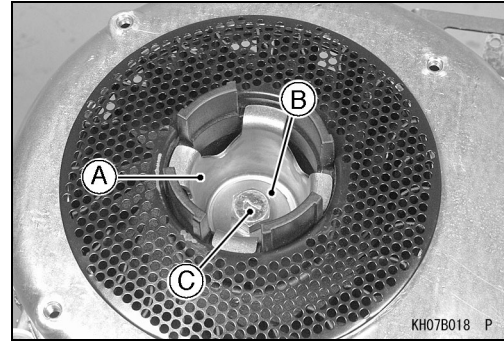

- Install the washer [A] as shown.
Flywheel Bolt [B]
- Install the other removed parts.

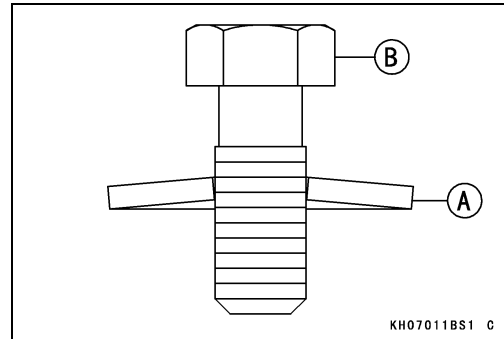

Charging, Ignition System

Circuit Composition

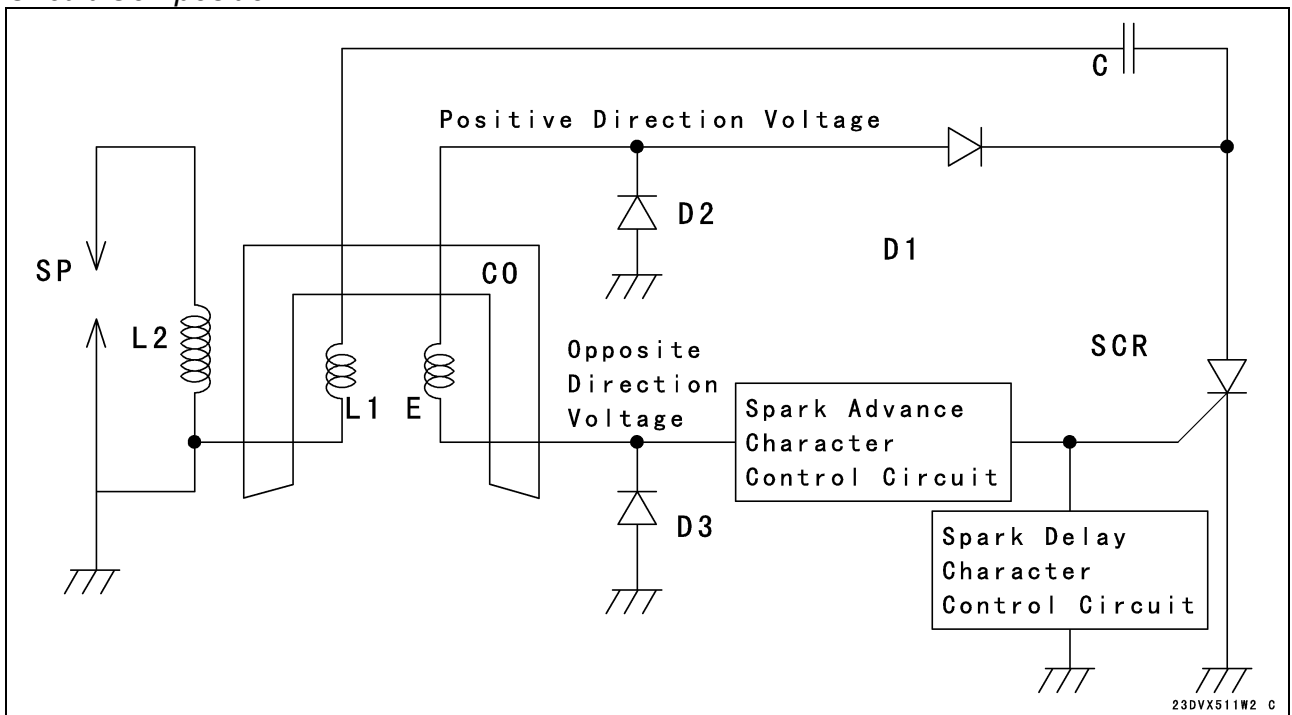

Co: Ignition Coil Core
 C: Condenser
 D1: Diode
 D2: Diode
 D3: Diode

E: Exciter Coil
 L1: Primary Coil
 L2: Secondary Coil
 SCR: Thyristor
 SP: Spark Plug

Action Principle

(1) Fundamental action

1. Generated positive direction voltage by rotor rotated in the exciter coil (E) flow the electrical current through the diode (D1), and discharged to the condenser (C).
2. Generated opposite direction current flow to the thyristor (SCR) because of voltage had generated in the exciter coil (E) also at the opposite direction.
3. If the voltage of opposite direction reaches to the trigger voltage of the thyristor (SCR), the thyristor (SCR) will be ON state, and voltage is charged by the condenser (C) discharge rapidly to the primary coil (L1).
4. The primary voltage of several hundreds volt generate because of large electrical current flows rapidly to the primary coil (L1), the primary voltage are pressure risen by the secondary coil (L2), and turn into the secondary voltage of several thousands volt, and spark generate to the spark plug (SP) of output side.

(2) Spark advance characteristic

1. If the revolutions number rises, the opposite direction voltage of exciter coil (E) which the trigger position of the thyristor (SCR) changes and spark advance because of voltage wave form will change.
2. Spark advance is controlled by spark advance characteristic control circuit in the figure.

(3) Spark delay characteristic

1. The trigger position of the thyristor (SCR) changes and spark delay by decreasing the voltage wave form applied to the thyristor (SCR) in the revolutions number set up in the spark delay characteristic control circuit in the figure.
2. The start revolutions number of spark delay is controlled by spark delay characteristic control circuit in the figure.

8-12 ELECTRICAL SYSTEM

Charging, Ignition System

Cautions of handling and maintenance

- (1) Do not near the magnet by the heat of fire.
- (2) Ignition timing is no adjustment because of it is fixed.
- (3) When carry out the spark test, pull the recoil starter knob with strong force. If the flywheel does not turned more than the ignition revolutions, spark does not ignite.

Ignition Coil Removal

- Remove:
 - Fan (see Flywheel Removal)
 - Spark Plug Cap
 - Earth Read Wire [A]
 - Bolts [B]
 - Ignition Coil [C]

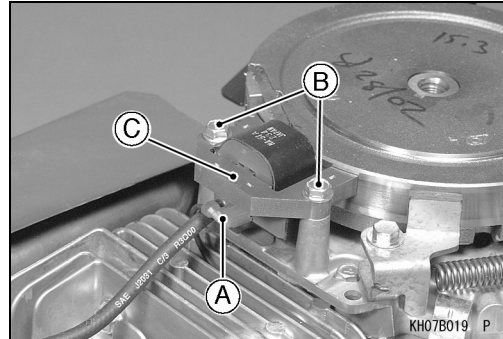

Ignition Coil Installation

- Install ignition coil [A] on crankcase and tighten bolt (1) first, then tighten bolt (2). While tightening bolts, adjust the air gap [B] between the leg of ignition coil and the magnet to the specified gap value as shown.

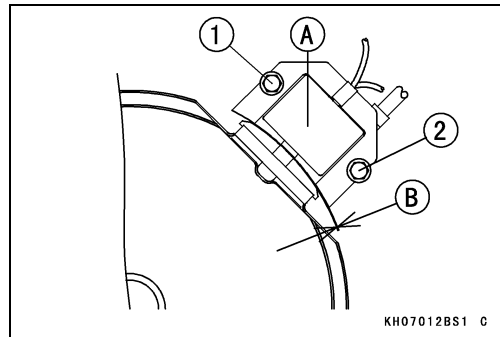

Ignition Coil Air Gap

Standard: 0.2 ~ 0.4 mm (0.008 ~ 0.016 in.)

NOTE

○ Above procedure must be used to insure proper coil air gap is not too large.

- Install:
 - Ignition Coil [A]
 - Bolts [B]
 - Earth Read Wire [C]
- When installing the earth read wire, put earth read wire between second and third fin.

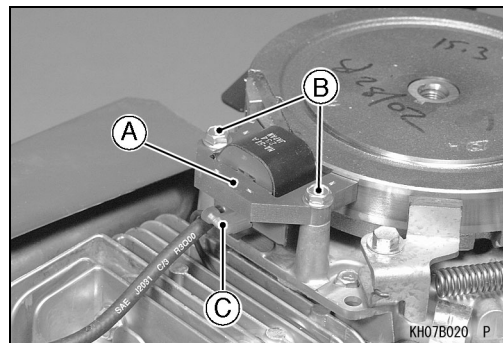

Charging, Ignition System

Ignition Coil Inspection

- Remove the ignition coil (see Ignition Coil Removal).
- Measure the winding resistance as follows.
- Set the hand tester to the R × 1 kΩ range.

Special Tool - Hand Tester: 57001-1394

- Make the measurements shown in the table.

Ignition Coil Winding Resistance

+	A	B	C
-			
A		300~400Ω	4 ~ 6 kΩ
B	350~450Ω		4 ~ 6 kΩ
C	4 ~ 6 kΩ	4 ~ 6 kΩ	

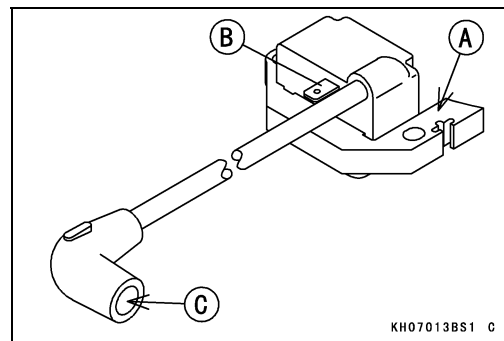

KH07013BS1 C

CAUTION

Use only Tester 57001-1394 with new battery at room temperature for this test. A tester other than the Kawasaki Hand Tester should show different readings.

If a megger or a meter with a large-capacity battery is used, the ignition coil will be damaged.

★If the tester does not read as specified, replace the coil.

Spark Plug Removal

- Carefully pull the plug cap from the spark plug.
- Remove the spark plug using a suitable plug wrench.

Spark Plug Installation

- Insert the spark plug vertically into the plug hole with the plug installed in the plug wrench.
- Tighten the plug.

Torque - Spark Plug: 22 N·m (2.2 kgf·m, 16 ft·lb)

- Fit the plug cap securely.
- Pull up the spark plug cap lightly to make sure of the installation of the spark plug cap.

Spark Plug Cleaning and Inspection

- Refer to Spark Plug Cleaning and Inspection in the Periodic Maintenance Chapter (2nd chapter).

Spark Plug Gap Inspection

- Refer to Spark Plug Gap Inspection in the Periodic Maintenance Chapter (2nd chapter).

8-14 ELECTRICAL SYSTEM

Starter System

Recoil Starter Removal

- Remove:
 - Recoil Starter Mounting Bolts [A]
 - Recoil Starter [B]

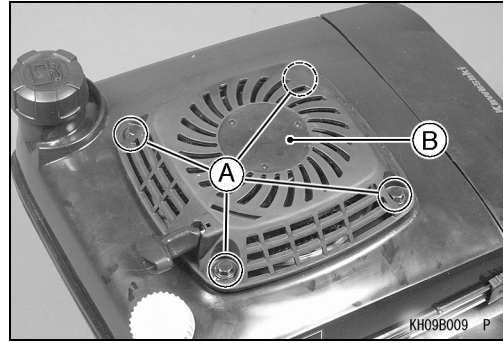

Recoil Starter Installation

- Install the recoil starter and tighten the mounting bolts.
Torque - Recoil Starter Mounting Bolts: 6.9 N·m (0.70 kgf·m, 61 in·lb)

Recoil Starter Disassembly

- Remove the recoil starter (see Recoil Starter Removal).
- Pull the starter knob [A] 30 cm (1 ft), and clamp the rope [B] with the clip [D] so it can not wind back onto the reel [C].
- Pry the knot [E] out of the starter knob and untie it.
- Remove the starter knob from the rope.

⚠ WARNING

Wear gloves to avoid injury for the remaining steps.

- While carefully holding the reel [A] and case [B], remove the clip.
- Unwind the spring tension slowly.

NOTE

○ Do not wedge the rope between the reel and case.

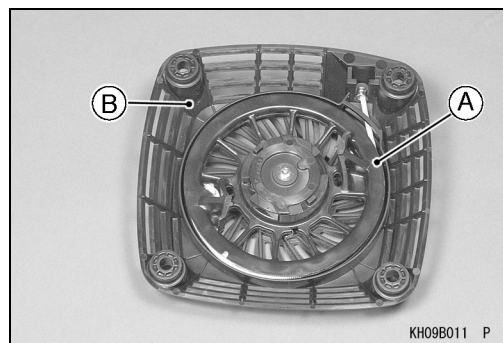
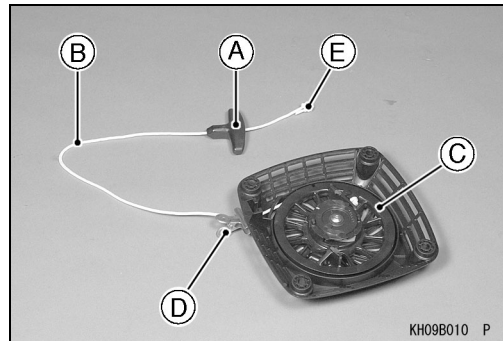

- Remove:
 - Set Screw [A]
 - Ratchet Guide [B]
 - Friction Spring [C]
 - Ratchets [D]
 - Reel [E]

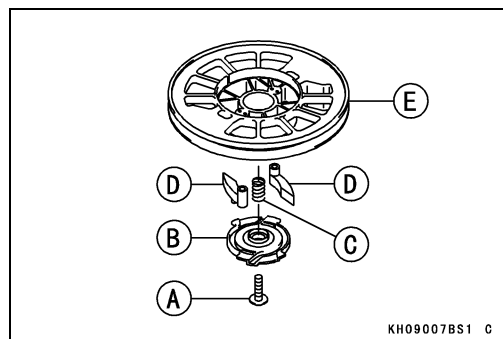

Starter System

⚠ WARNING

When removing the reel [A], be careful that the spiral spring [B] in the reel does not fly loose and cause injury. The spring is under great pressure.

NOTE

○ There should be no spring tension on the reel when removing it. If tension is felt, push the reel back into place and gently “wiggle” it until the reel can be easily removed.

- Slowly lift the reel straight up out of the case [C].

⚠ WARNING

Be careful that the spiral spring does not fly loose and cause injury. The spring is under great pressure.

- ★ If the spiral spring must be removed, hold the reel facing downward in a suitable container and remove the spiral spring by tool.

Recoil Starter Assembly

⚠ WARNING

Wear gloves during the spiral spring installation to avoid injury. The spiral spring must be assembled with great pressure.

- Apply grease the spiral spring.
- Wind the rope clockwise [A] on the reel, and hold the rope end [B] with tape.
- Install the spiral spring by tool.

- Apply grease the shaft [A].
- Put the reel with the notch [B] aligned with the spring inner tongue [C].
- At that time engage the spiral spring with the starter case.
- Turn the reel clockwise until you feel the hang hook on the catch.

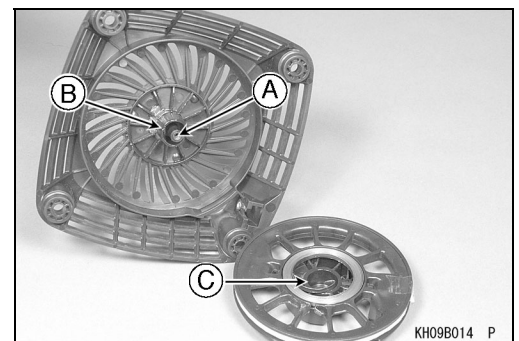
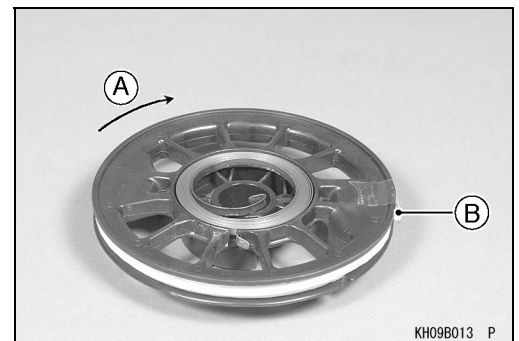
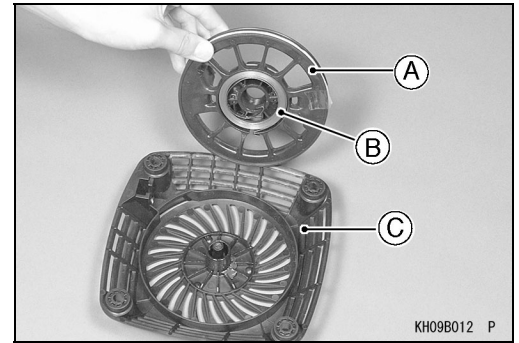

8-16 ELECTRICAL SYSTEM

Starter System

- Remove the tape.
- Install:
 - Ratchets [A]
 - Friction Spring [B]

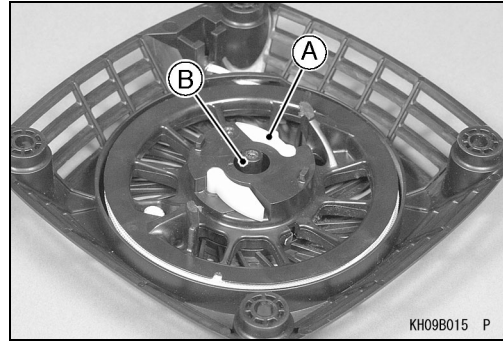

- Install the ratchet guide [A].
- Tighten the set screw [B].
 - Torque - Recoil Starter Set Screw: 1.0 N·m (0.10 kgf·m, 8.9 in·lb)**
- Turn the reel two turns counterclockwise to preload the spiral spring.

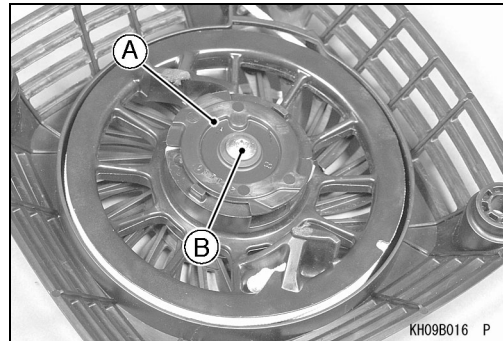

- While holding the reel to keep it from unwinding, feed the end of the rope through the hole in the case.
- Clip [A] the rope as shown to hold it.
- Install the starter knob [B] and secure it with a knot [C].
- Remove the clip to release the rope.

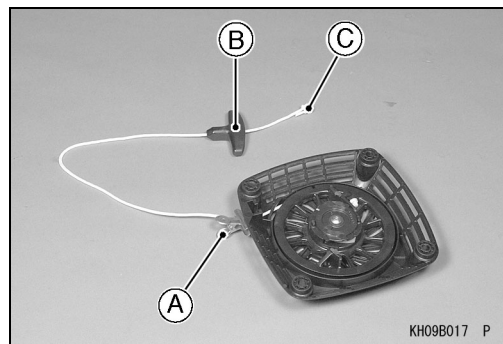

Pad Brake

Pad Brake Assembly Removal

- Remove:
 - Air Cleaner (see Fuel System chapter)
 - Recoil Starter (see Electrical System chapter)
 - Fuel Tank (see Fuel System chapter)
 - Pulley (see Flywheel Removal)
 - Fan Housing and Fan (see Flywheel Removal)
- Remove the brake lever assembly mounting bolt [A].
- Remove the spring [B] from the lever assembly and remove the lever assembly [C].
- Remove the spring [B] and bolt [D].

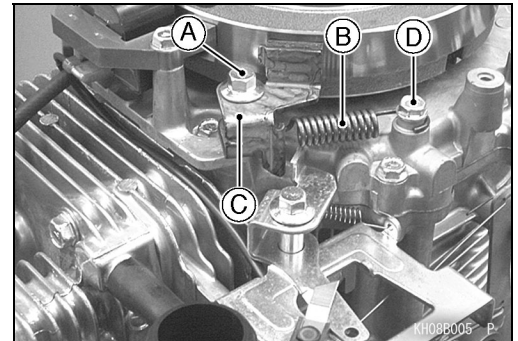

- Remove the earth read wire from the ignition coil.
- Remove the control panel assembly (see Fuel System chapter).
- Remove the spring [A] from the brake panel assembly.
- Remove the spring [A].
- Remove the brake arm mounting bolt [B] and nut [C].
- Remove the brake arm and brake panel.

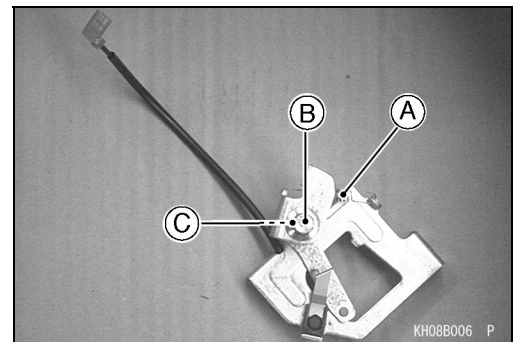

CAUTION

Make sure that pad brake always stop engine within 3 seconds when pad brake is ON. If not, check brake shoe and/or related parts for wear and damage. Replace parts if necessary.

Pad Brake Assembly Installation

- Install the brake arm [A], brake panel [B] and spring [C] as shown.
- Install the brake arm mounting bolt and nut.
 - Torque - Brake Arm Mounting Bolt: 9.3 N·m (0.95 kgf·m, 82 in·lb)**
- Install the brake panel assembly and control panel assembly (see Fuel System chapter).
- Install the earth read wire in the ignition coil (see Ignition Coil Installation).

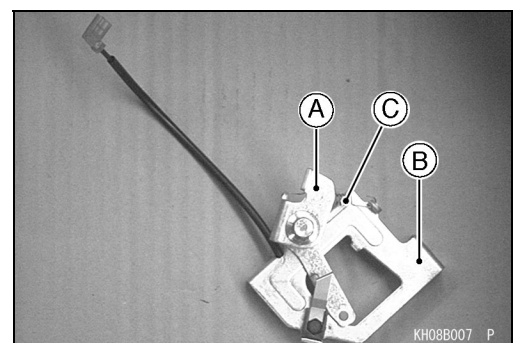

8-18 ELECTRICAL SYSTEM

Pad Brake

- Tighten the bolt [A].
 - Install the lever assembly [B].
 - Tighten the brake lever assembly mounting bolt [C].
- Torque - Brake Lever Assembly Mounting Bolt: 6.9 N·m (0.70 kgf·m, 61 in·lb)**
- Check the lever assembly move smoothly was installed.
 - Install the spring [D].
 - Install the other removed parts.
 - Adjust the high idle speed to the specifications (see Periodic Maintenance chapter).

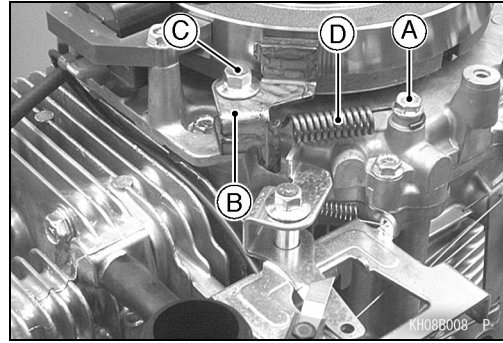

Brake Switch Removal/Installation

- Refer to the illustration shown for removal and installation.
- Nut [A]
 - Washer [B]
 - Earth Read Wire [C]
 - Cover [D]
 - Brake Panel Assembly [E]
 - Insulator [F]
 - Terminal [G]
 - Kill Switch Bolt [H]
- Torque - Kill Switch Bolt: 1.5 N·m (0.15 kgf·m, 13 in·lb)**

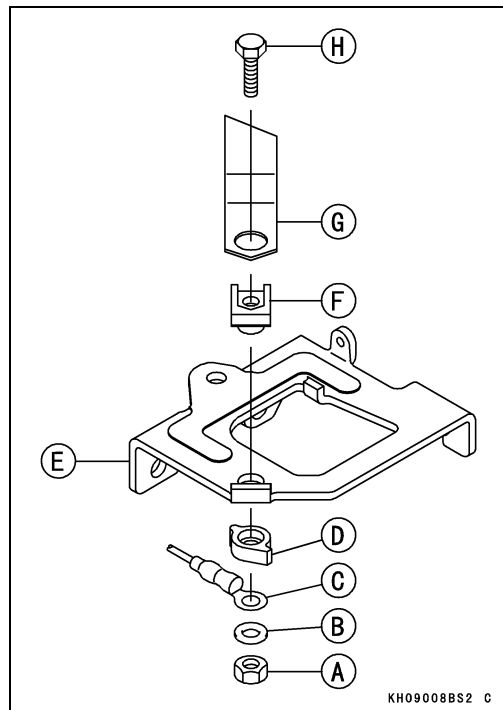

- Install the brake switch [A] so that face out as shown.

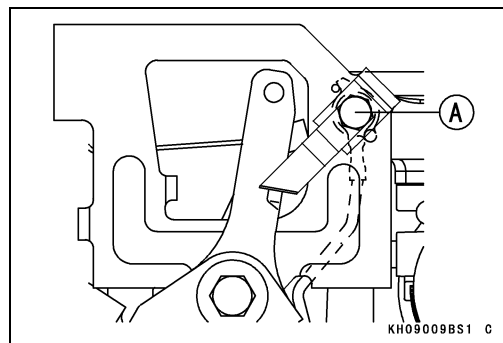

Troubleshooting

TABLE OF CONTENTS

Engine Troubleshooting Guide	9- 2
------------------------------------	------

9-2 TROUBLESHOOTING

Engine Troubleshooting Guide

If the engine malfunctions, check if the way the engine is used is correct. If engine malfunctions even if engine is used correctly, systematically carry out troubleshooting starting with simple points.

This chart describes typical troubleshooting procedures.

It's not necessary to disassemble carburetor, magneto or engine unless it has been found to be the cause of the malfunction.

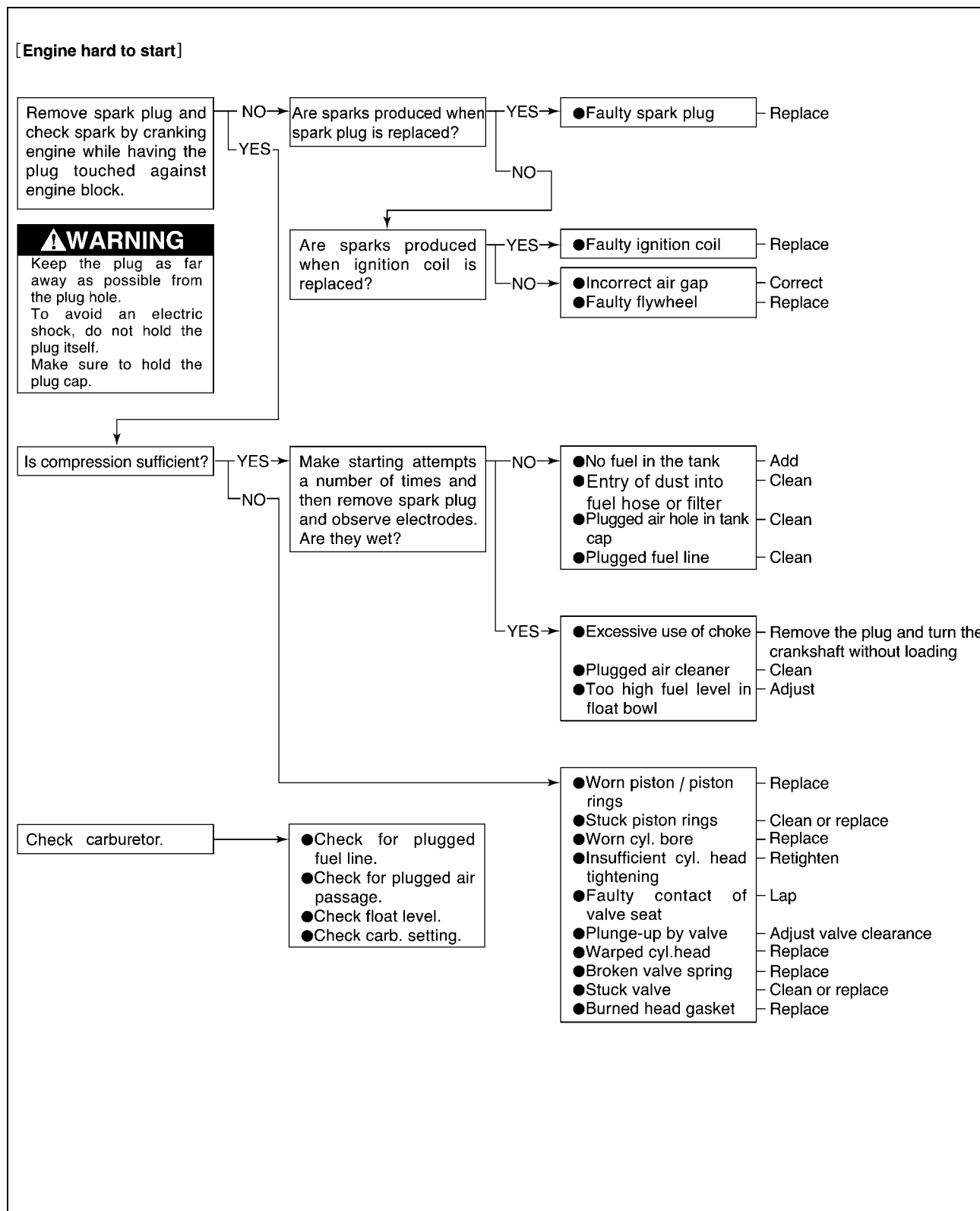

Engine Troubleshooting Guide

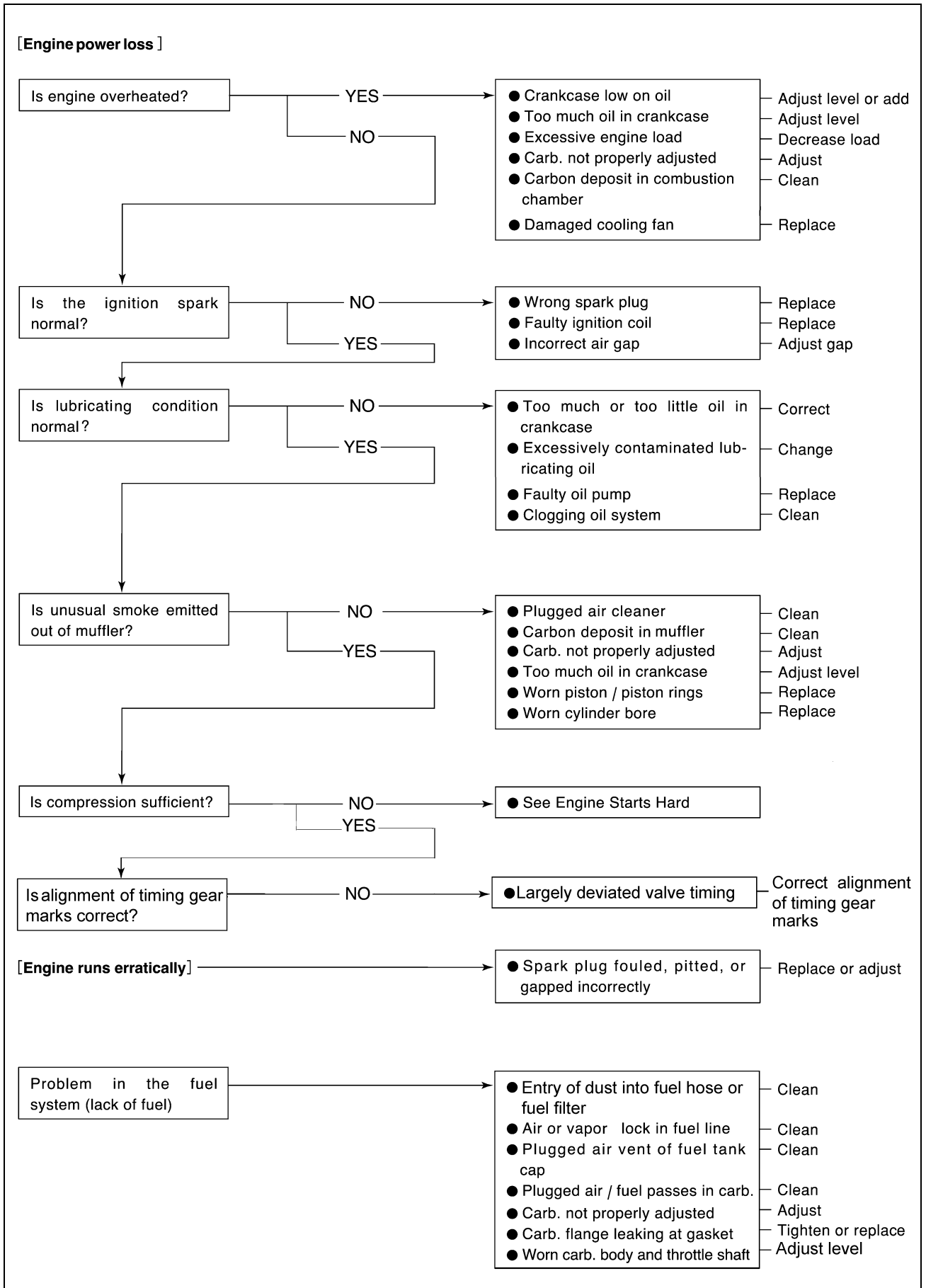

9-4 TROUBLESHOOTING

Engine Troubleshooting Guide

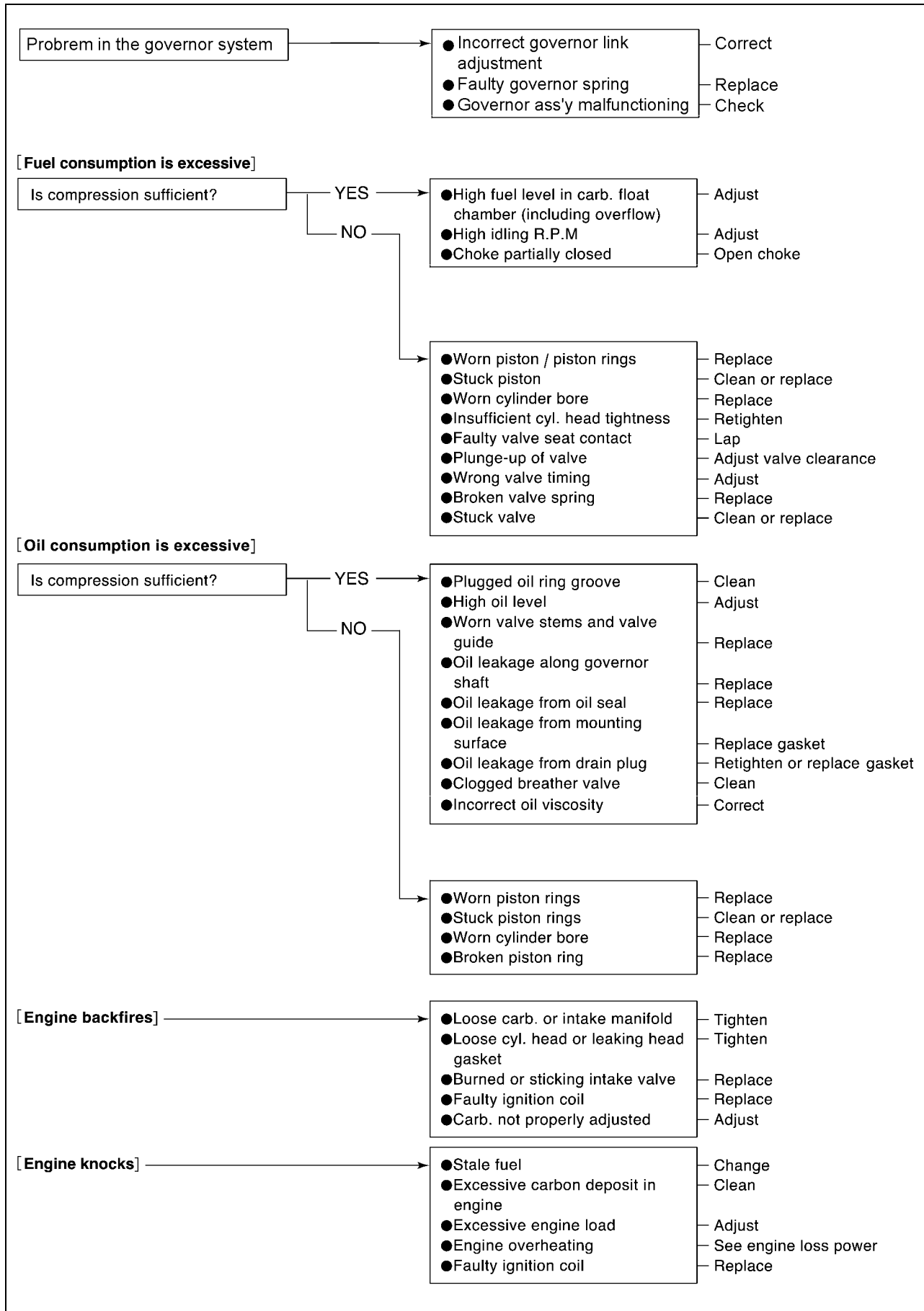

Engine Troubleshooting Guide

[Engine hard to stop]

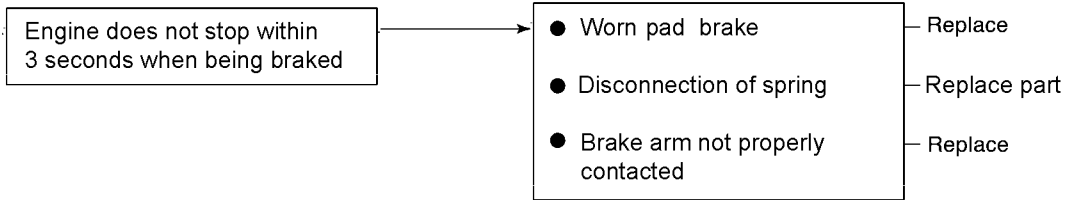

[Faulty operation of priming pump]

