

Service Handbook

High-Pressure Washer Pump

3.532-785.0

10.00

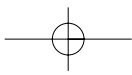
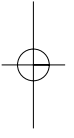
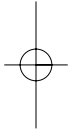
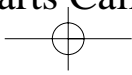

How to Use This Manual

It is not necessary to read this entire manual to find a solution to a problem. This manual identifies four basic ways the pump may malfunction. Find the section that defines the malfunction of the pump. Turn to that section's overview page and identify the specific problem. Then go to the solutions page for that specific problem. If you don't know what the problem is, work your way through the problems listed until you find and correct the problem.

Low Water Pressure Section 1

Water Leaks Section 2

Oil Leaks Section 3

Detergent Delivery Failure Section 4

Always wear safety rated eye protection and clothing.
For any other problems contact KARCHER® technical support at **1-800-877-2424**.

Tools Necessary to Service the KARCHER® High-Pressure Washer Pump Part 3.532-757.0

Special Tools

- Valve pliers 4.901-062
- Installation tool 2.901-034 (HP seal, oil seal)
- Silicon grease 6.288-044 (for packing and O-rings)
- Lithium grease 6.288-079 (for O-rings on bypass valve)
- Non-detergent pump oil 6.288-050.0

Generic Tools

- Allen Wrench 8mm
- Allen Wrench 6mm
- Torx TX30 Socket Wrench
- Needle Nose Pliers
- Rubber Mallet
- Pliers
- Flat Head Screwdriver
- Phillips Head Screwdriver
- Hammer
- Safety Goggles

MASTER DIAGRAM

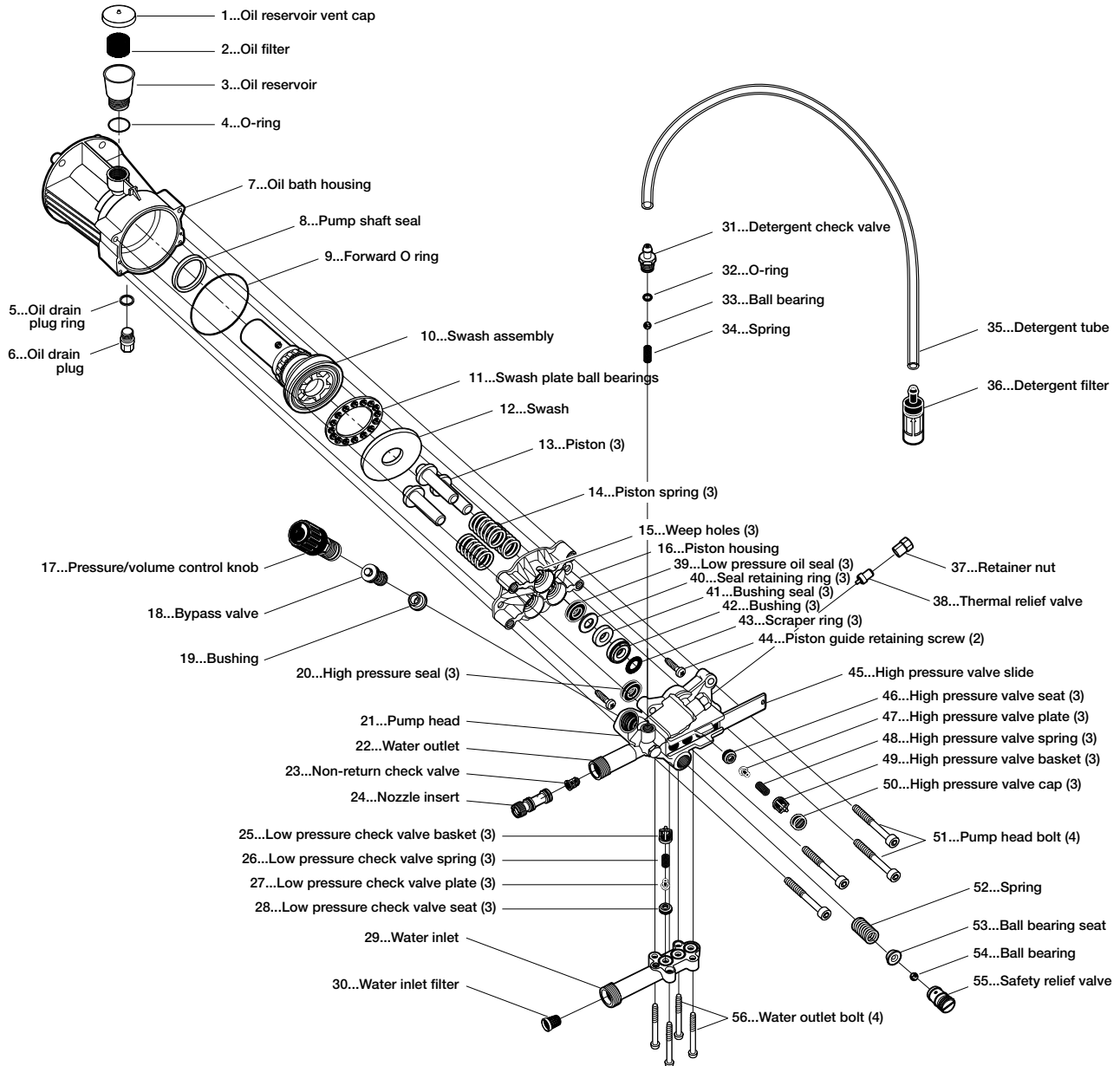

Swash Plate Assembly

The three pistons (13) are driven by the swash plate assembly (10), which is mounted to the engine shaft. In the case of a vertically configured machine, a drive bolt is screwed into the engine shaft and then inserted into the pump shaft. As soon as the engine shaft rotates, the swash assembly (10) rotates as well. This causes the pistons (13) to move backwards and forwards. The piston stroke depends upon the angle of the swash assembly (10). The greater the angle of the swash plate, the longer the piston stroke. One revolution of the swash plate gives the pistons one suction stroke and one pressure stroke.

Oil Bath

The swash plate assembly and pistons are bathed in oil (oil type 15W40 non-detergent). The oil level should be just above the high side of the swash plate (12). It is important that the machine is on level ground when checking the oil level.

In order to drain the oil, the drain plug (6), located beneath the oil bath housing (7) will have to be removed. To add oil, remove the vent cap (1) from the oil reservoir (3) and add to the required level.

Note: Some pumps do not have a drain plug, or oil reservoir. In order to add oil in this case, the pump head (21) and piston housing (16) will have to be removed.

Pistons With Seals

The three pistons (13) are pressed against the swash plate (12) of the swash plate assembly (10) by powerful springs (14). These three pistons are manufactured from tempered, surface-hardened steel and are non-corrosive with regards to detergents and rust.

The pump delivery capacity is determined by

- the rotational speed of the motor
- the diameter of the pistons
- the length of the piston stroke.

The pistons (13) in industrial units are fitted with a high-pressure seal (20) and a low-pressure seal (39). Non-industrial units have only a high-pressure seal (20).

The three pistons each have an oil seal (39) mounted in the piston housing (16). These three oil seals, along with the shaft seal (8), retain the oil in the oil bath housing. The weep holes (15) are in the piston housing (16) and allow water or oil to drip out into the open.

A water leakage rate of one drop per piston per minute is allowable during high-pressure operation. If oil is leaking from the weep holes (15), there is either a leak in the oil seals or there is piston damage.

Low-Pressure and High-Pressure Check Valves

Each piston works with one low-pressure check valve (25-28) and one high-pressure check valve (46-49). Each of these check valves is constructed of the same basic components: the valve cage, spring, valve plate with guide shaft and the valve seat with O-ring.

The sealing surface between the valve plate (27 & 47) and the valve seat (28 & 46) is conical. The valve plate and valve seat are manufactured from either plastic or stainless steel depending upon the particular unit involved.

When the piston (13) is forced backwards by the spring (14) in the oil bath housing (7), the high-pressure check valve (46-49) closes and water is drawn in through the supply line / suction chamber at the water inlet (29), through the inlet filter (30), and through the open low-pressure check valve (25-28).

When the piston (13) is pushed forward by the swash assembly (10), the low-pressure check valve (25-28) closes and water is conveyed through the open high-pressure check valve (46-49) to the water outlet (22). The pressure that is generated is dependent upon the flow rate and the orifice diameter of the high-pressure nozzle.

Bypass Valve with Pressure Adjustment

When the trigger of the spray gun is pulled, the entire pump capacity flows through the nozzle insert (24) to the water outlet (22). At this time, the bypass valve (18) remains in the upper position and closes off the path between the pressure chamber and the suction chamber.

When the trigger of the spray gun is released, water ceases to flow through the nozzle insert (24). The non-return check valve (23) closes, and the pressure in the high-pressure hose is maintained between the trigger-actuated valve in the spray gun and the non-return check valve (23). The pressure instantly rises in a surge, which causes the bypass valve (18) to be pressed downwards. This opens the path between the pressure chamber, located above the bypass valve (18), and the water inlet housing (29). The pump continues to run only in bypass mode. The safety relief valve (55) will open if the bypass valve (18) fails to activate.

When the trigger of the spray gun is again pulled, the pressure in the high-pressure hose drops suddenly. The spring inside the bypass valve (18), together with the restricted pressure at the entrance to the nozzle insert (24), pushes the bypass valve upwards. This causes the circulation between the pressure chamber and the water inlet (29) to close, and the pump builds up pressure once more.

This pump has a pressure/volume control (17) that enables you to adjust the pressure and water flow at the pump. Other pumps have a fixed pressure rating and are non adjustable. The pump shown in the diagram is adjustable. This adjustment is made by turning the pressure/volume control (17) downwards. This causes the bypass valve (18) to be pushed open in a continuous movement. A part of the pump's capacity then flows from the pressure chamber into the water inlet housing (29) and the operating pressure drops to the amount that has been set by turning the pressure/volume control (17).

Thermal Protection Device

If the pump should continue to run in the bypass mode for an extended amount of time (max 5 min.), the water circulating within the pump will reach a temperature level that will cause internal damage. This is prevented by the thermal relief valve (38). The thermal relief valve will release the hot water and then automatically reset itself.

Detergent Delivery System

In this system there is a nozzle insert (24) in the water outlet (22). The entire pump capacity flows through the nozzle insert to the spray gun.

Detergent can only be drawn in by the nozzle insert (24) if the nozzle of the spray wand has been set to low pressure. This causes the pump pressure to fall to approximately 435 PSI (low pressure), and the greatest degree of negative pressure (11.6 PSI) is generated at the lateral hole in the nozzle insert so that detergent can be drawn into the unit via the detergent suction tube (35) and detergent filter (36).

If the spray nozzle on the spray wand is set for high-pressure operation, the hole in the nozzle insert (24) does not create any

KARCHER OVERVIEW

negative pressure, and no detergent can be drawn into the unit.

The detergent check valve consists of a small spring (31) with a ball, O-ring and nipple. When operating in the detergent mode, the negative pressure created by the nozzle insert causes the ball to be drawn

away from the O-ring, against the tension of the spring. Detergent can then be drawn into the unit.

When operating in the high-pressure mode, the ball seals off the detergent connection so that no water can flow into the container of detergent.

PART NUMBERS

High Pressure Washer Pump 3.532-785.0

ITEM #(S)	DESCRIPTION	PART #	QTY. IN PUMP	ITEM #(S)	DESCRIPTION	PART #	QTY. IN PUMP
1	Oil reservoir cap	5.063-651.0	1	28	Water inlet housing	5.063-897.0	1
2	Oil filter	5.132-107.0	1	29	Water inlet filter	6.414-252.0	1
3	Oil reservoir	5.070-194.0	1	30	Detergent check valve	5.443-448.0	1
4	O-ring	6.362-168.0	1	31	O-ring	6.362-175.0	1
5	Oil drain plug ring	7.362-003.0	1	32	Ball-bearing	7.401-909.0	1
6	Oil drain plug	7.382-085.0	1	33	Spring	5.332-258.0	1
7	Oil bath housing	5.093-207.0	1	34	Detergent tube	6.388-216.0	1
8	Pump shaft seal	7.387-018.0	1	35	Detergent filter	4.862-032.0	1
9	Forward o-ring	6.363-067.0	1	36	Retainer nut	5.411-150.0	1
10	Swash plate assembly with	5.120-326.0	1	37	Thermal relief valve	5.413-067.0	1
	Cylinder bearing	7.401-027.0	1	38	Low pressure oil seal	6.365-340.0	3
	Coupling element	4.120-192.0	1	39	Seal retaining ring	5.115-465.0	3
	Spring	7.318-002.0	1	40	Bushing seal	6.365-434.0	3
11	Swash plate ball bearings	6.401-185.0	1	41	Bushing	5.112-576.0	3
12	Swash plate	5.120-326.0	1	42	Scraper ring	5.115-744.0	3
13	Piston	5.553-434.0	3	43	Piston guide retaining screw	7.303-047.0	2
14	Piston spring	6.332-427.0	3	44	High pressure valve slide	5.003-983.0	1
15	Piston housing	5.060-677.0	1	45,46 47,48	High-pressure valve cage, spring, plate and seat	4.580-371.0	3
16	Pressure/volume control knob with Spindle	5.321-307.0 4.401-079.0	1	50	Pump head bolts	7.306-047.0	4
17	Bypass valve (multiple numbers)			51	Spring	5.332-446.0	1
	top o-ring set	6.362-454.0	1	52	Ball-bearing seat	5.411-070.0	1
	piston	5.553-383.0	1	53	Ball-bearing	7.401-909.0	1
	spring	5.332-425.0	1	54	Safety relief valve	5.583-164.0	1
	valve seat	5.581-242.0	1	55	Water outlet bolt	7.306-105.0	4
	valve seat o-ring	6.362-169.0	1				
	threaded spindle	5.305-274.0	1				
18	Bushing	5.110-630.0	1	NOT PICTURED IN DIAGRAM			
19	High-pressure seal	6.365-432.0	3		Garden hose connection	9.154-009.0	1
20	Pump head	5.550-266.0	1		Piston spring retaining clip	7.343-478.0	3
21	Water outlet	5.063-897.0	1				
22	Non-return check valve	5.584-091.0	1				
23	Nozzle insert	5.769-138.0	1				
24, 25 26, 27	Low-pressure check valve basket, spring, plate and seat	4.580-371.0	3				

SECTION 1 / LOW WATER PRESSURE

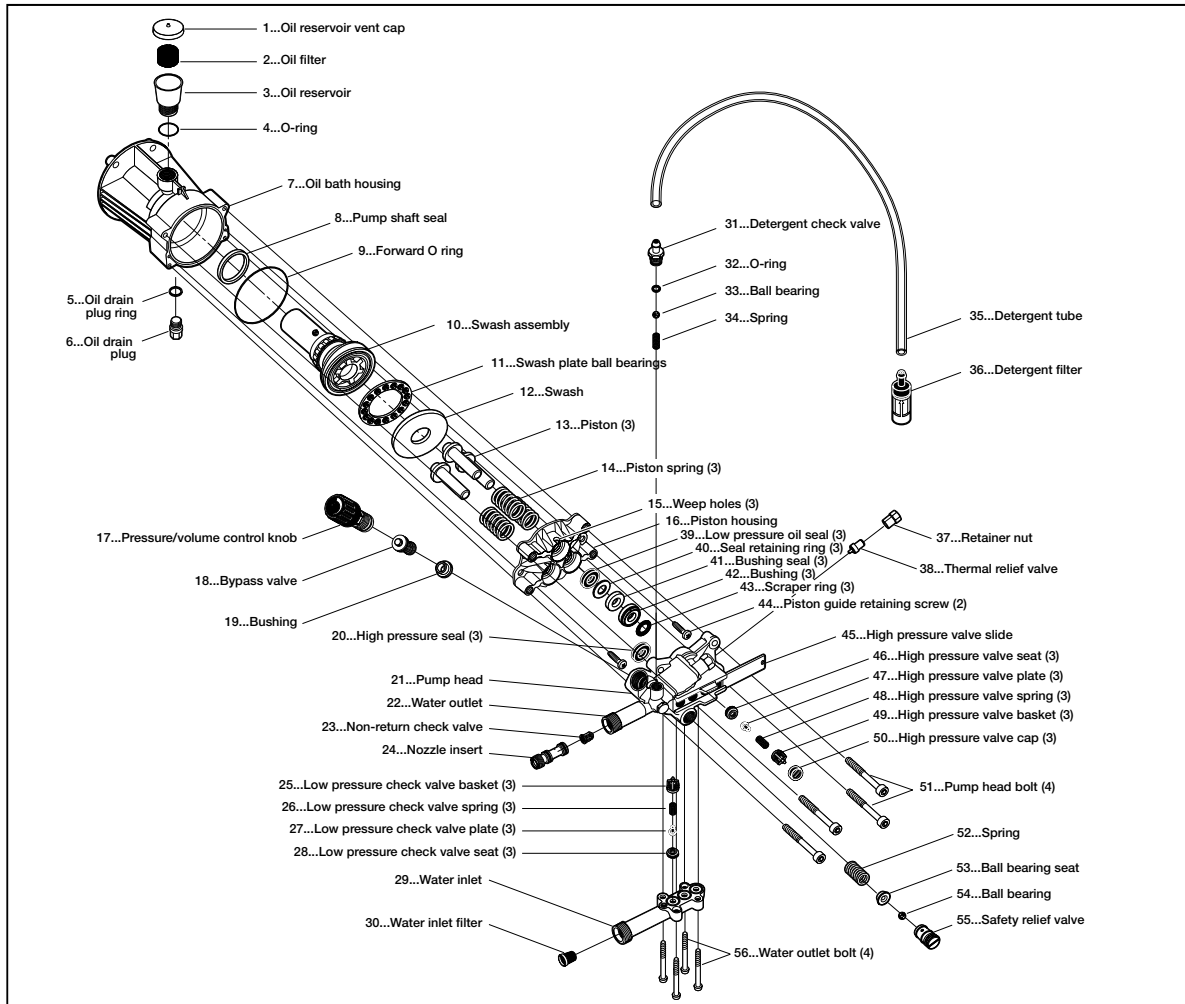

Problems That Cause Low Water Pressure

- A. Water Supply**
A problem with the water supply. Use cold water only.
- B. Worn Nozzle**
A worn nozzle on the spray wand.
- C. Water Inlet Filter**
A clogged water inlet filter (30).
- D. Bypass Valve**
Worn O-rings on the bypass valve (18) or the bypass valve is hanging up.
- E. Safety Relief Valve**
The safety relief valve (55) opens if the bypass valve (18) is not working. Low water pressure can result if the valve (55) does not seal or does not reset.
- F. Low-Pressure Check Valve**
Low-pressure check valve (26-28) fails to function properly.
- G. High-Pressure Check Valve**
High-pressure check valve (46-49) fails to function properly.
- H. Water Leaks – See Section 2 / Water Leaks**
Water leaks.
- I. Pump is Cycling – See Section 4 / Detergent Delivery Failure**
Non-return check valve (23) or Nozzle insert (24) is damaged and must be replaced.

SECTION 1 / LOW WATER PRESSURE SOLUTIONS

- A. Water Supply
- B. Nozzle
- C. Water Inlet Filter
- D. Bypass Valve
- E. Safety Relief Valve

A. Water Supply

1. Check faucet. 4.0 gpm is required.
2. Outside diameter of hose should be 3/4".
3. Maximum length of hose should be 50'.
4. The inlet water pressure should not exceed 90 psi.
5. Hose should not be kinked or damaged.

B. Nozzle

1. Check function and setting of original nozzle by using an in-house nozzle. If pump functions properly with in-house nozzle but malfunctions with original nozzle, replace nozzle.

C. Water Inlet Filter

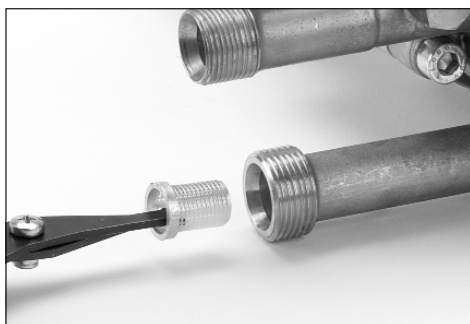

figure 1

1. Remove filter with pair of valve pliers. (figure 1)
2. Clean filter.
3. Replace filter if it is torn, bent or missing.
4. Reinstall filter.

Note: If water inlet filter is missing or damaged, further damage may have occurred inside the pump.

D. Bypass Valve

1. Unscrew pressure volume control assembly. (figure 2)



figure 2

8

2. Remove brass bushing. (figure 3)
Note that bushing is positioned with large side down.

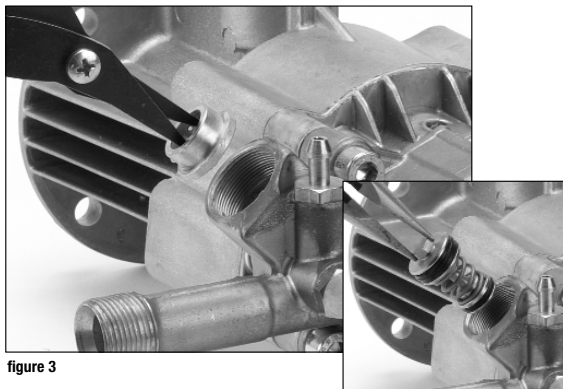

figure 3

3. Pull out bypass valve. (inset figure 3)
4. Inspect bypass valve for damage and lubrication. Inadequate lubrication will cause valve to hang up.
5. Inspect O-rings for nicks or cuts. Replace if necessary.

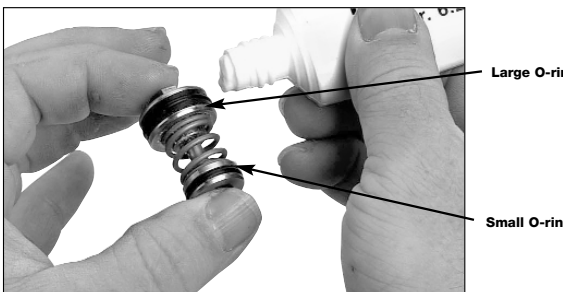

figure 4

6. Grease only large O-rings with lithium grease. (figure 4)
7. Replace bypass valve if necessary.

E. Safety Relief Valve

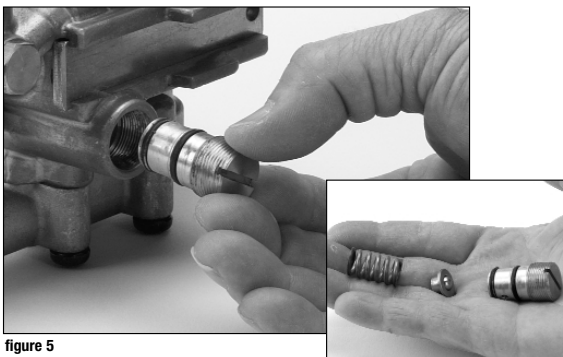

figure 5

1. Unscrew the safety relief valve screw cap. (figure 5)
2. Remove spring, valve seat and ball. (inset figure 5)
3. Check for wear or pitting.
4. Replace valve if necessary.
5. If valve seat in the cylinder head is defective, the entire safety relief valve must be replaced.
6. Reassemble and replace screw cap making sure ball is in seat.

Note: Pitting will occur if inlet filter is damaged or missing.

SECTION 1 / WATER PRESSURE SOLUTIONS

F. Low-pressure Check Valve

1. Remove water inlet housing with torx TX30 bit (5 bolts). (figure 6)
2. Remove low-pressure check valve, including valve disk and spring, with special valve pliers. (figure 7)
3. Check the valve for wear, debris and pitting.

Note: If any one low-pressure valve is damaged, all three valves should be replaced.

4. Lightly grease O-rings with silicone grease.

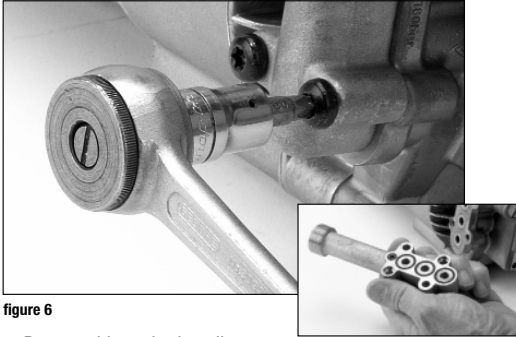

figure 6

5. Reassemble and reinstall.

Note: Low-pressure check valves must be ordered as a unit. Individual check valve parts cannot be ordered separately.

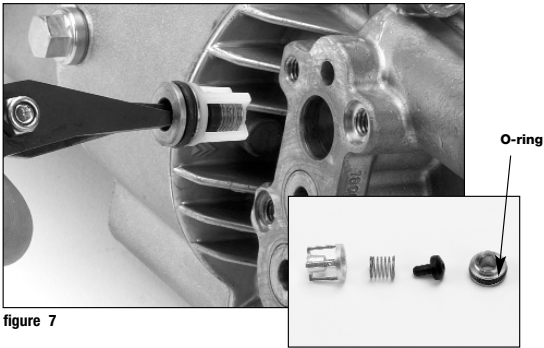

figure 7

G. High-pressure Check Valve

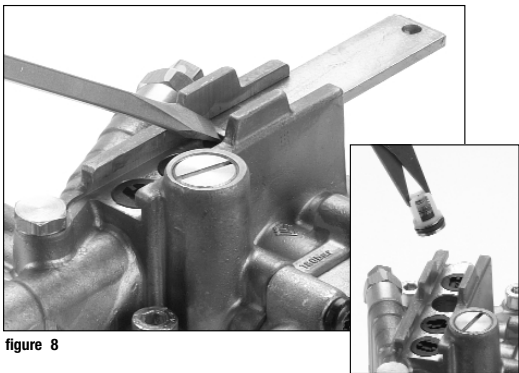

figure 8

1. Remove valve plate in tapping plate with screw driver.

- F. Low-Pressure Check Valve
- G. High-Pressure Check Valve
- H. Water Leaks
- I. Pump Cycling

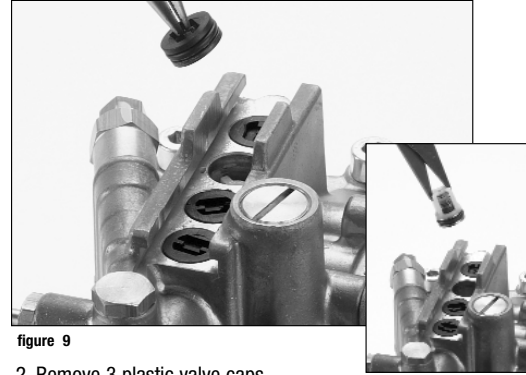

figure 9

2. Remove 3 plastic valve caps.
3. Check the valve for wear, debris and pitting. Replace if necessary.

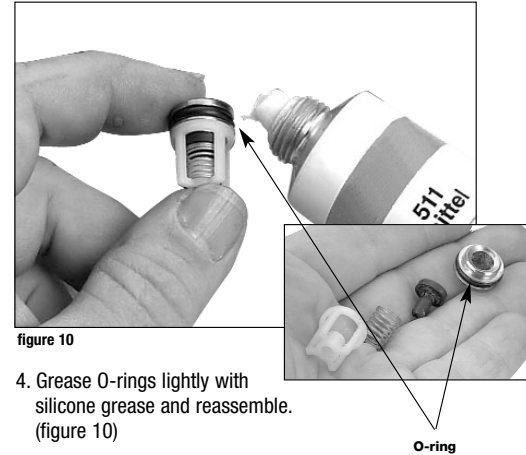

figure 10

4. Grease O-rings lightly with silicone grease and reassemble. (figure 10)

H. Water Leaks – See Section 2 / Water Leaks

I. Pump is Cycling – See Section 4 / Detergent Delivery Failure

SECTION 2 / WATER LEAKS

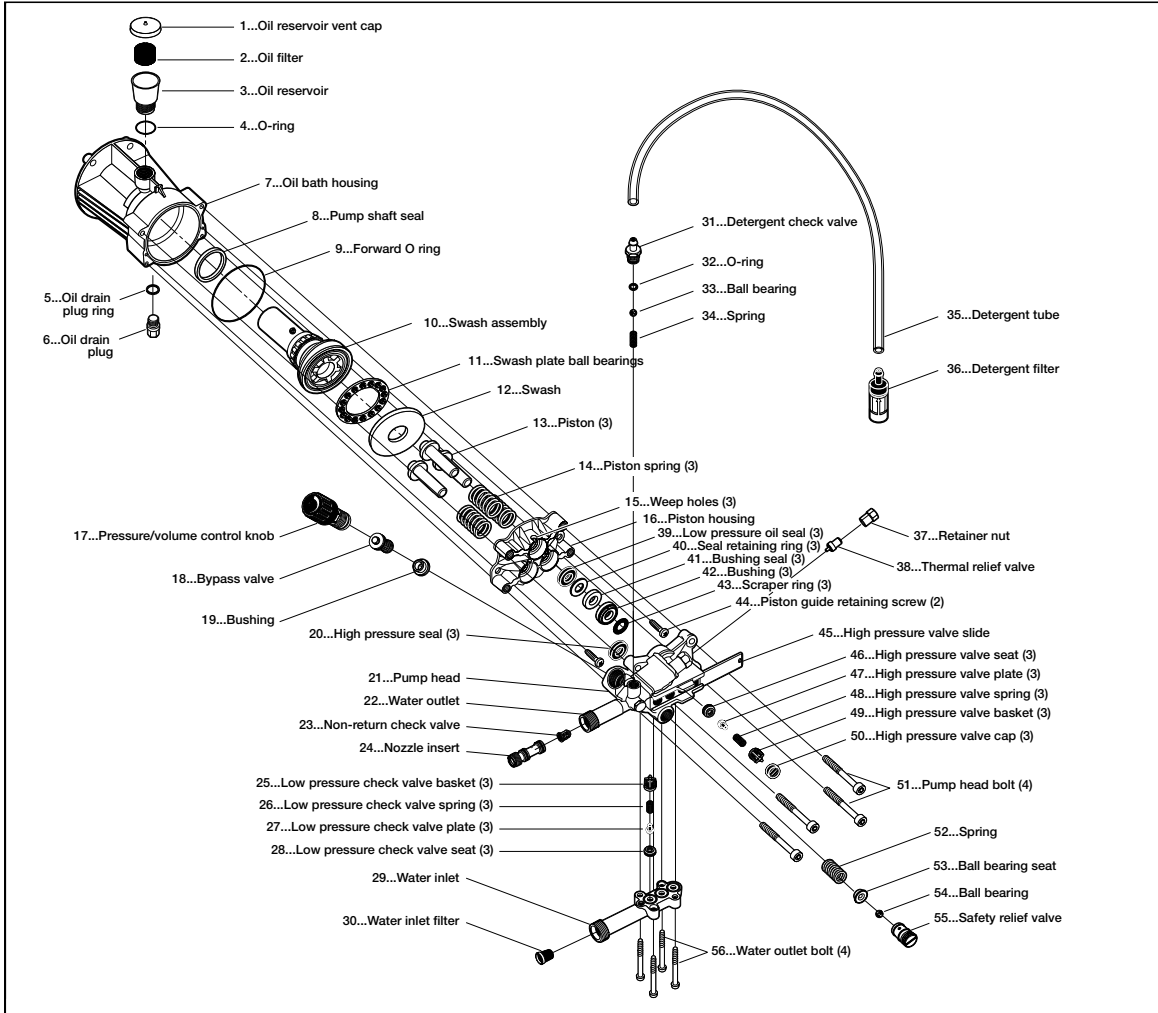

Problems That Cause Water Leaks

A. Thermal Relief Valve

The thermal relief valve (38) protects the pump from hot water temperatures in bypass mode. If the thermal relief valve is damaged or does not reset, there will be a continual leak. Check thermal relief valve (38).

Note:

It is normal for the thermal relief valve to release hot water, if the pump continues to run in the bypass mode for an extended amount of time, which causes the water circulating within the pump to reach a temperature level that will cause internal damage. Once the valve releases the hot water, it will automatically reset itself.

B. weep holes – High-Pressure Seals

Water leaking from the weep holes (15) can indicate a leak in the high-pressure seals. Check seals for damage.

C. weep holes – Low-Pressure Seals

Water leaking from the weep holes (15) can indicate a leak in the low-pressure seals (39). Check the seals for damage.

SECTION 2 / WATER LEAK SOLUTIONS

A. Thermal Relief Valve

1. Remove thermal relief valve screw cap. (figure 11)

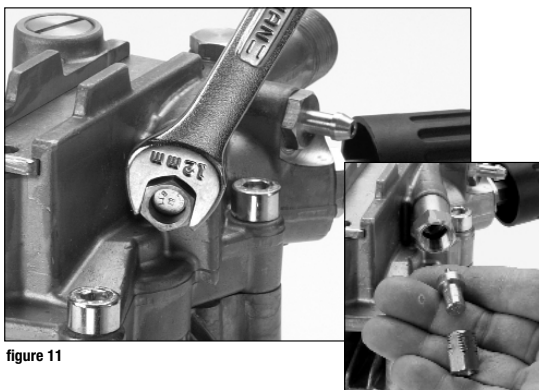

figure 11

2. Disassemble thermal relief valve. (inset figure11)
3. Inspect and replace with new valve if necessary.

B. weep holes - High-Pressure Seals

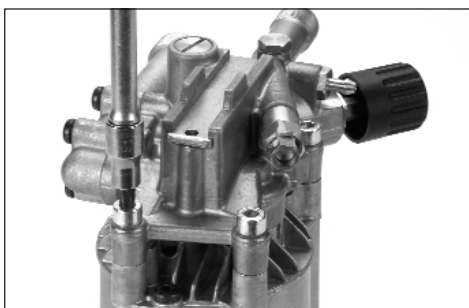

figure 12

1. Remove 4 pump head bolts using 6mm allen wrench. (figure 12)
2. Remove pump head.

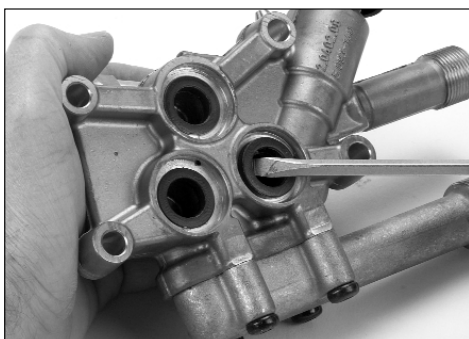

figure 13

3. Carefully remove the 3 high-pressure seals. (figure 13)
4. Check seals and pistons for wear and tear and replace if necessary. See Section 3 / Oil Leaks, D. weep holes for piston replacement.
5. Replace all three seals using installation tool.

- A. Thermal Relief Valve
- B. weep holes – High-Pressure Seals
- C. weep holes – Low-Pressure Seals



figure 14

- Place seal, flat side down, on installation tool.
- Fill groove with silicone grease. (figure 14)

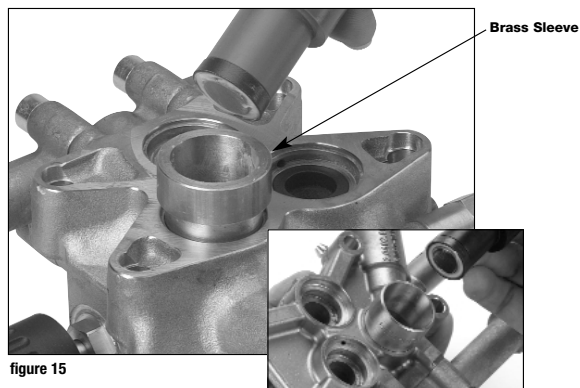

figure 15

- Place brass sleeve in pump head.
- Put installation tool into sleeve and press until seal pops into place. (figure 15)
- Remove tool and then remove sleeve. (inset figure 15)

SECTION 2 / WATER LEAK SOLUTIONS

C. weep holes – Low Pressure Seals

C. weep holes - Low-Pressure Seals

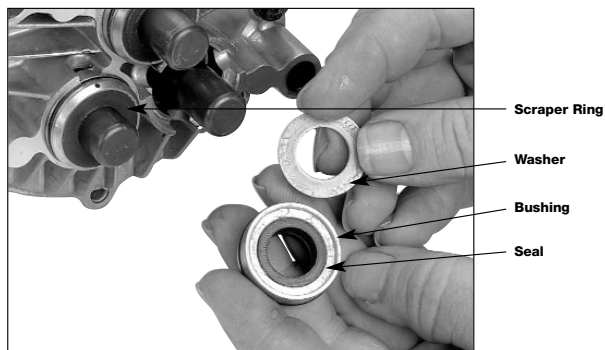

figure 17

1. Remove low-pressure bushing from piston.
(figure 17)
2. Remove washer from bushing.
(figure 17)

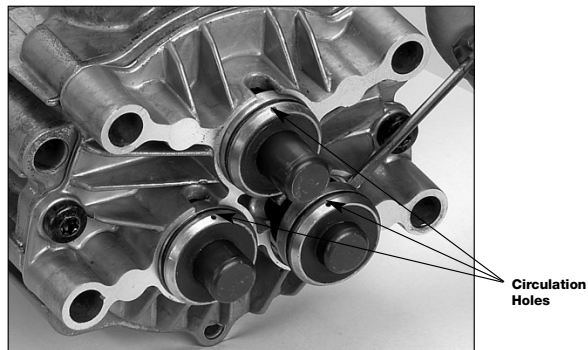

figure 19

7. Place bushing back on piston.
Circulation holes must line up with weep holes.
(figure 19)

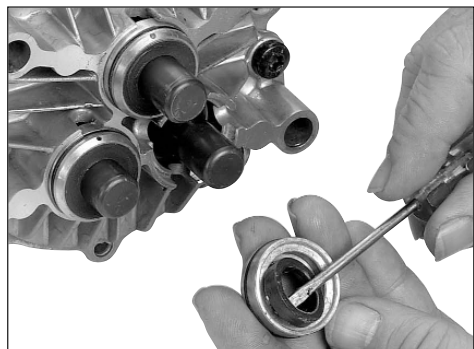
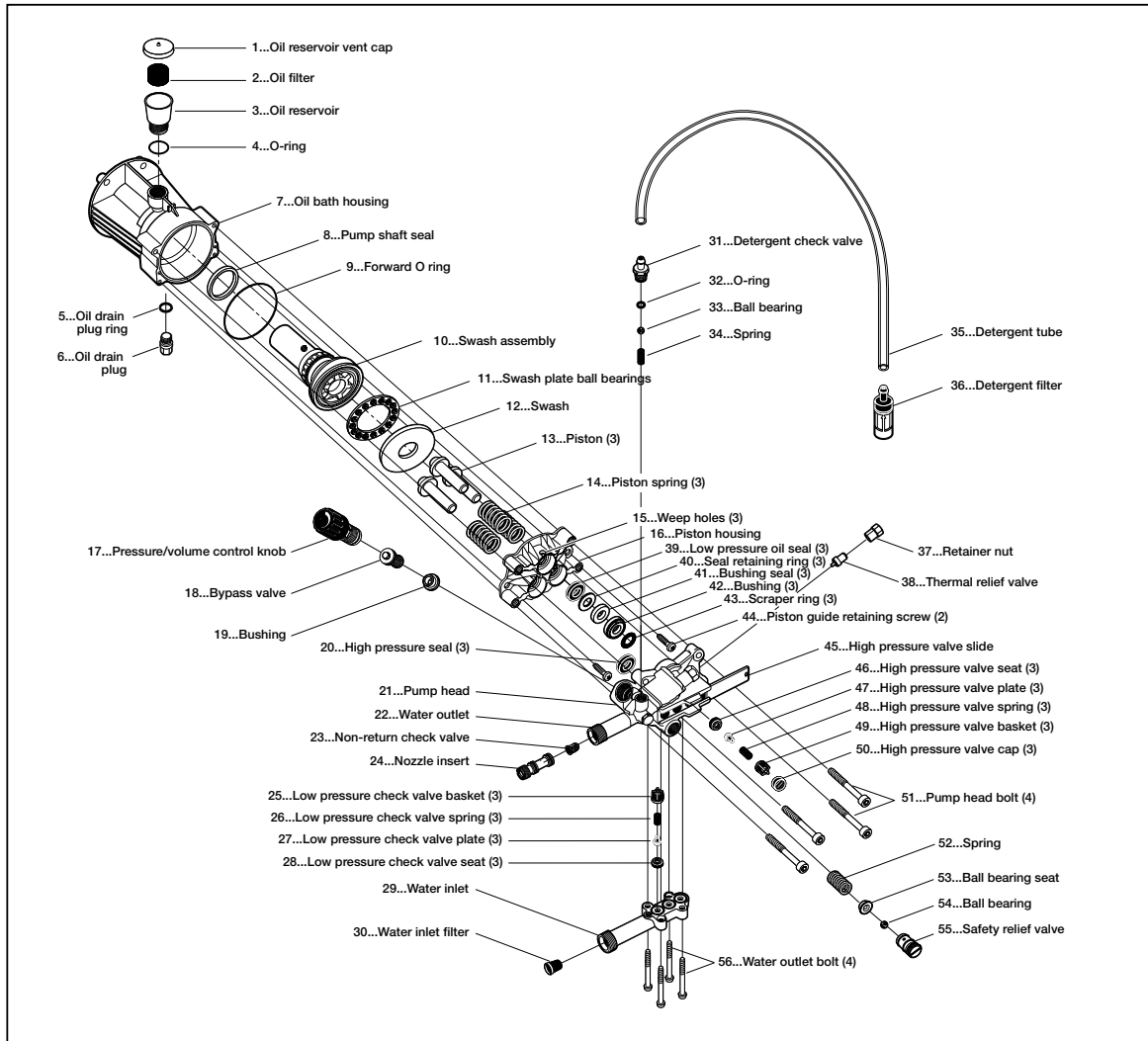

figure 18

3. Remove low pressure seal.
(figure 18)
4. Inspect scraper ring. Replace if damaged.
5. Inspect O-ring on bushing.
6. Apply silicone grease to seal



Problems That Cause Oil Leaks

A. Drain Plug

A loose drain plug (6) or damaged drain plug ring (5).

B. Oil Reservoir

A damaged oil reservoir (3), missing oil reservoir filter (2), or damaged O-ring (4).
If the oil bath housing (7) is overfilled, oil will leak from vent cap (1).

C. Weep holes

If oil is leaking from the weep holes (15), there is either a leak in the low-pressure seals (39) or the high-pressure seals (20); or there is piston (13) damage.

D. Pump Shaft Seal

A damaged or worn pump shaft seal (8).

SECTION 3 / OIL LEAK SOLUTIONS

- A. Drain Plug
- B. Oil Reservoir
- C. weep holes / Oil Seals

A. Drain Plug (figure 20)

1. Check drain plug. Tighten or replace if necessary.
2. Inspect drain plug seal. Replace if necessary.

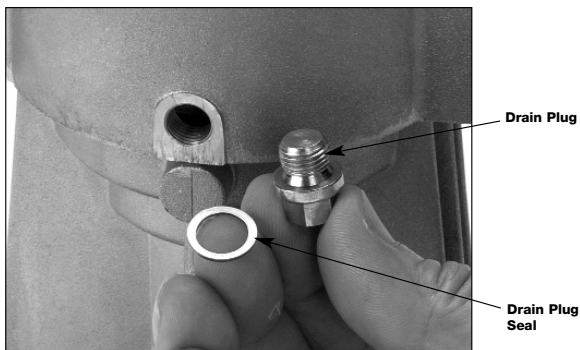

figure 20

3. Reassemble and reinstall the drain plug.

B. Oil Reservoir (Figure 21)

1. If oil is spurting from oil reservoir vent cap, the oil level is too high. Drain to specified level. (See note in Section 2.)
2. Inspect oil reservoir, seal and filter for damage.
3. Replace if necessary.

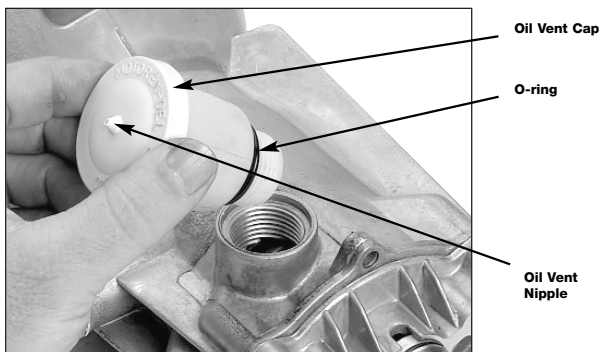

figure 21

4. Check that vent nipple is cut.
5. Check O-ring under oil reservoir. If pitted or deformed, replace.

C. weep holes – Oil Seals

1. Unscrew the oil drainage plug and drain the oil into a suitable container.

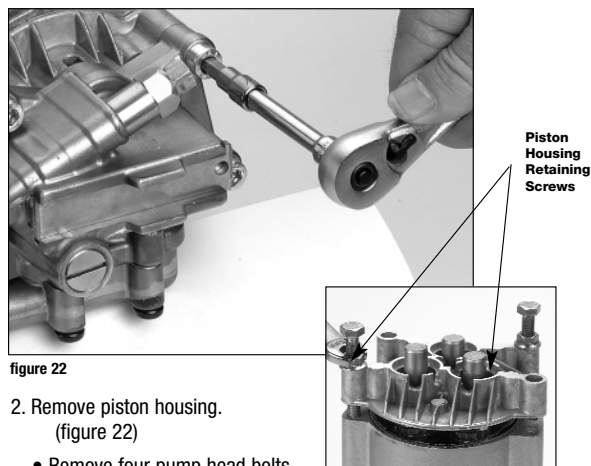

figure 22

2. Remove piston housing. (figure 22)
 - Remove four pump head bolts with an allen wrench and remove the pump head. (See Section 2, figure 12)
 - Re-install two of the pump head bolts with a 1/2" shim composed of washers or a metal sleeve about 3/8" in diameter into two diagonally opposing weep holes of piston guide housing. (figure 22)
 - Remove the two piston guide retaining screws.
 - Back off the housing by loosening up on the two pump head bolts until spring tension in the piston guide housing is relieved. (inset figure 22)
 - Alternate between nuts after every few turns to keep housing level.
 - Remove the two pump head bolts and shim when spring tension is relieved.

SECTION 3 / OIL LEAK SOLUTIONS

D. weep holes / Oil Seals
E. Pump Shaft Seal

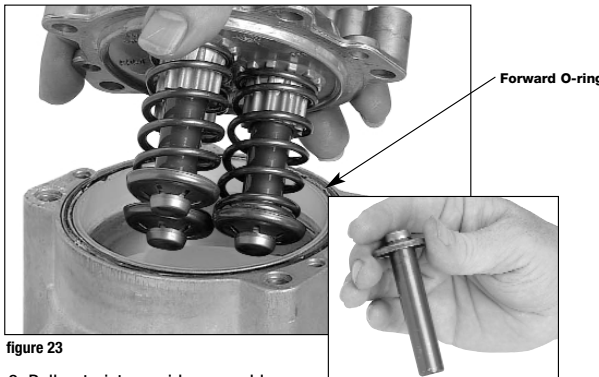

figure 23

3. Pull out piston guide assembly. (figure 23)
4. Inspect forward O-ring and seal. Replace if necessary.
5. Remove and inspect pistons for wear or scoring. Replace if necessary.

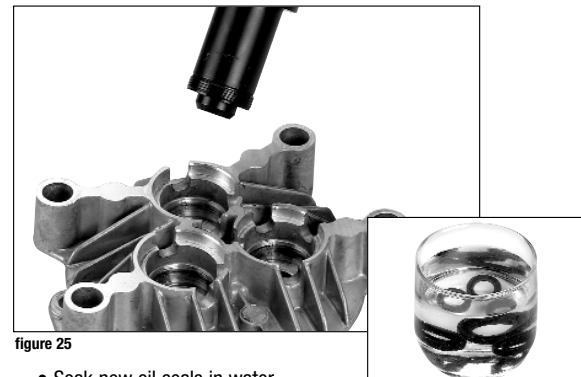

figure 25

- Soak new oil seals in water for 10 minutes. (inset figure 25)
- Make sure housing is clean and dry.
- Place oil seal into recessed end of installation tool. Sleeve is not used. Groove in seal should face oil.
- Place seal in housing using installation tool. (figure 25)
- Do not grease groove in oil seal.
- Push until seal hits bottom.



figure 24

7. Remove the 3 oil seals with flat head screwdriver. (figure 24)
8. Inspect and replace oil seals if necessary.

D. Pump Shaft Seal

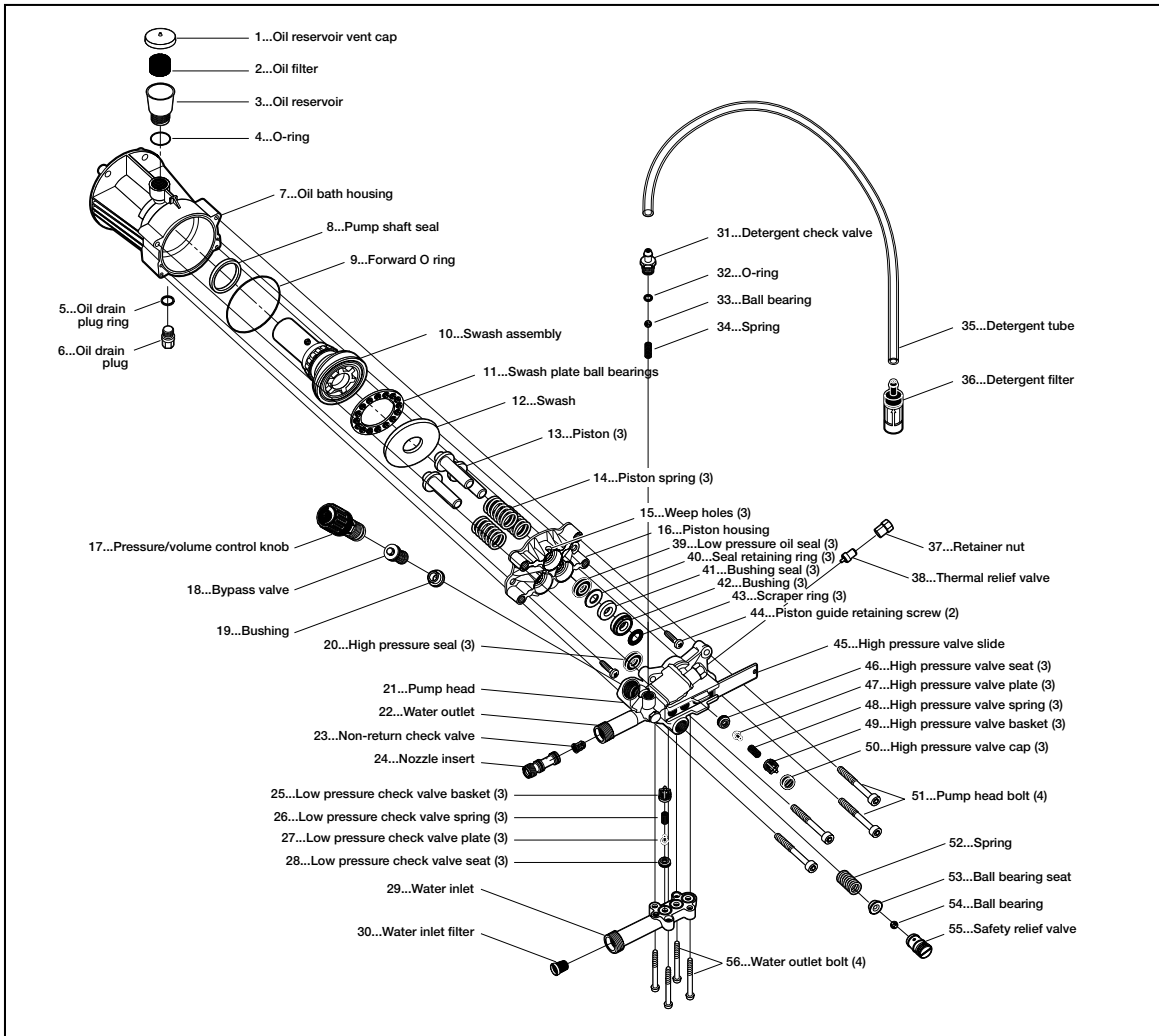

figure 26

Forward O-ring

1. Remove swash plate assembly. (figure 26)
2. If oil seal on shaft is worn out call 1-800-KARCHER.
3. To remove oil seal, push shaft through swash plate.

SECTION 4 / DETERGENT DELIVERY FAILURE



Detergent Delivery Failure

A. Pump Not Drawing Detergent or Water Exiting Detergent Tube

Detergent filter (36) or Detergent non-return check valve (31) may be clogged or damaged.
 Nozzle insert (24) may be worn.
 Nozzle of the spray wand has been set to high pressure

B. Pump Is Cycling

Non-return check valve (23) or Nozzle insert (24) is damaged and must be replaced.

SECTION 4 / DETERGENT DELIVERY FAILURE SOLUTIONS

- A. Pump Not Drawing Detergent or Water Exiting from Detergent Tube
- B. Nozzle Insert

A. Pump Not Drawing Detergent or Water Exiting Detergent Tube



figure 27

1. Check that nozzle is in low/chemical position. (figure 27)



figure 28

2. Check that metering valve on pickup filter is open. (figure 28)
3. Check pickup filter for clog.
4. Check detergent tube for holes and kinks.

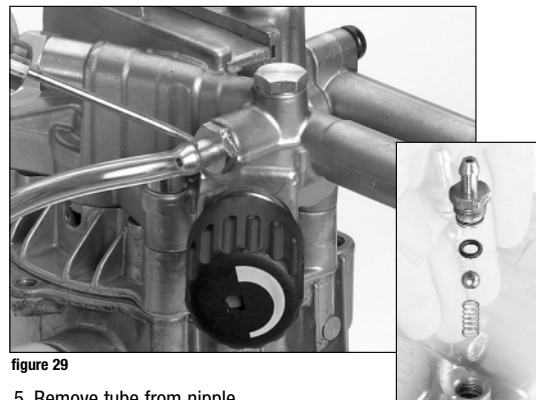

figure 29

5. Remove tube from nipple
 - Remove detergent non-return check valve. (figure 29)
 - Inspect non-return check valve for clogs.

Note: Leaving detergent in pump will cause ball to stick.

6. Reinstall non-return check valve, nipple, metering knob and hose.

B. Nozzle Insert

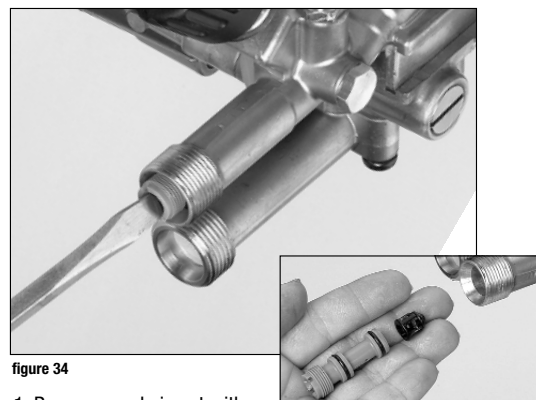

figure 34

1. Remove nozzle insert with a screwdriver.
2. Pull out nozzle insert. (figure 34)
3. Check nozzle for wear and damage.
4. Check that opening through nozzle is not clogged. Clear opening if necessary.