

For Husqvarna Parts Call 606-678-9623 or 606-561-4983

Husqvarna

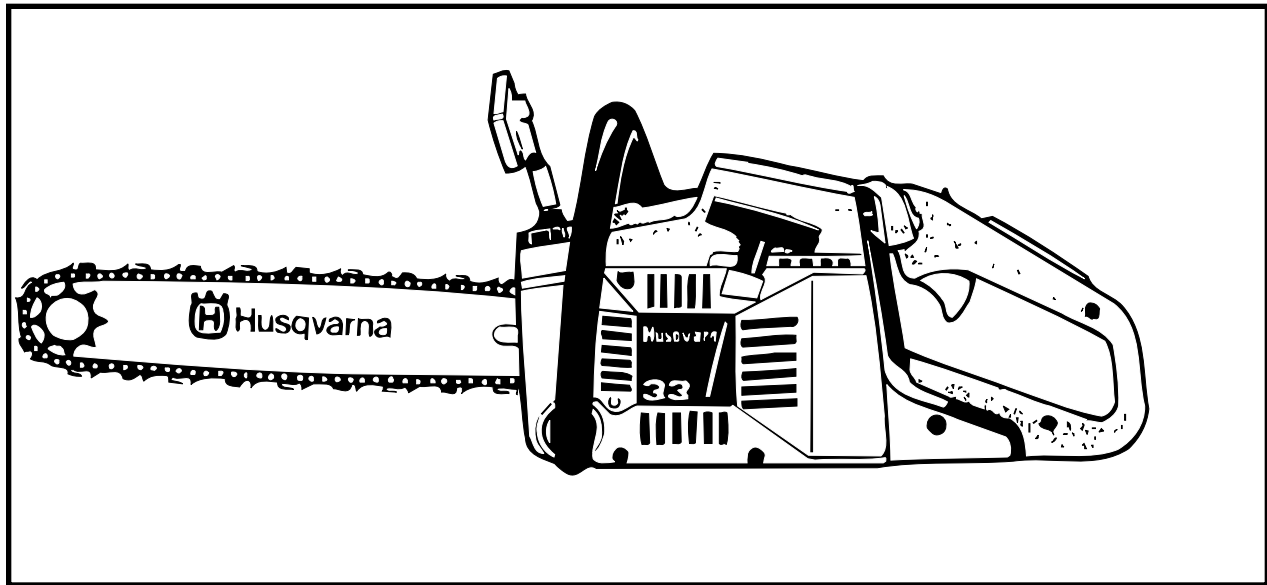

Husqvarna 33

Workshop Manual

507 43 36-22

Husqvarna 33

Introduction

This workshop manual is mainly intended for Husqvarna 33, but certain chapters can also be used for other models. The manual gives information about how to repair the saw and how to use our special tools. In order to make sure that the saw will function, always use Husqvarna 33 original spare parts and accessories.

- 1.** Service data
- 2.** Service tools
- 3.** Technical specification
- 4.** Safety equipment
- 5.** Starter device
- 6.** Electronic system
- 7.** Centrifugal clutch
- 8.** Lubrication system
- 9.** Fuel system
- 10.** Engine unit
- 11.** Trouble-shooting chart

1 SERVICE DATA

TIGHTENING TORQUES, ETC.

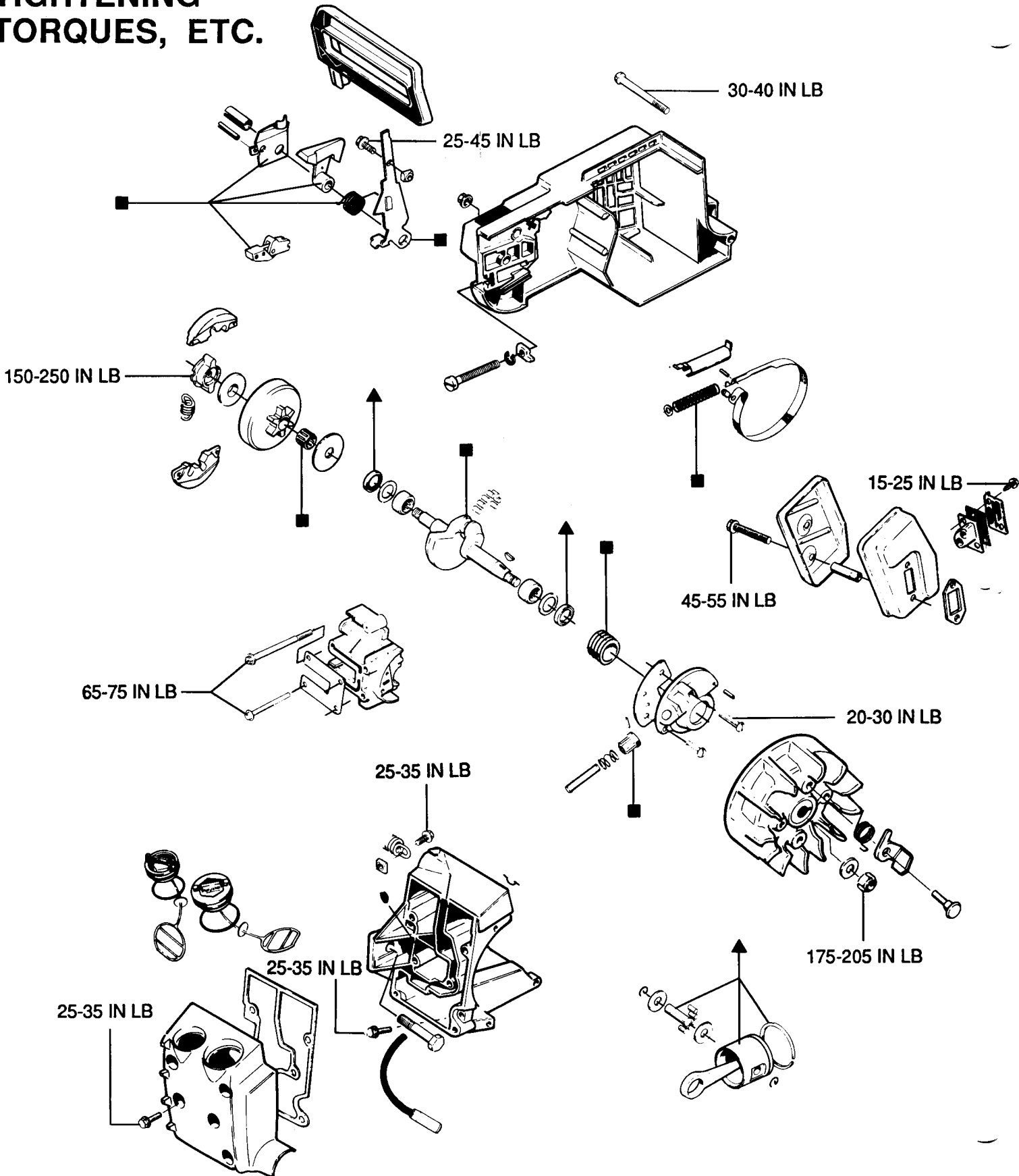

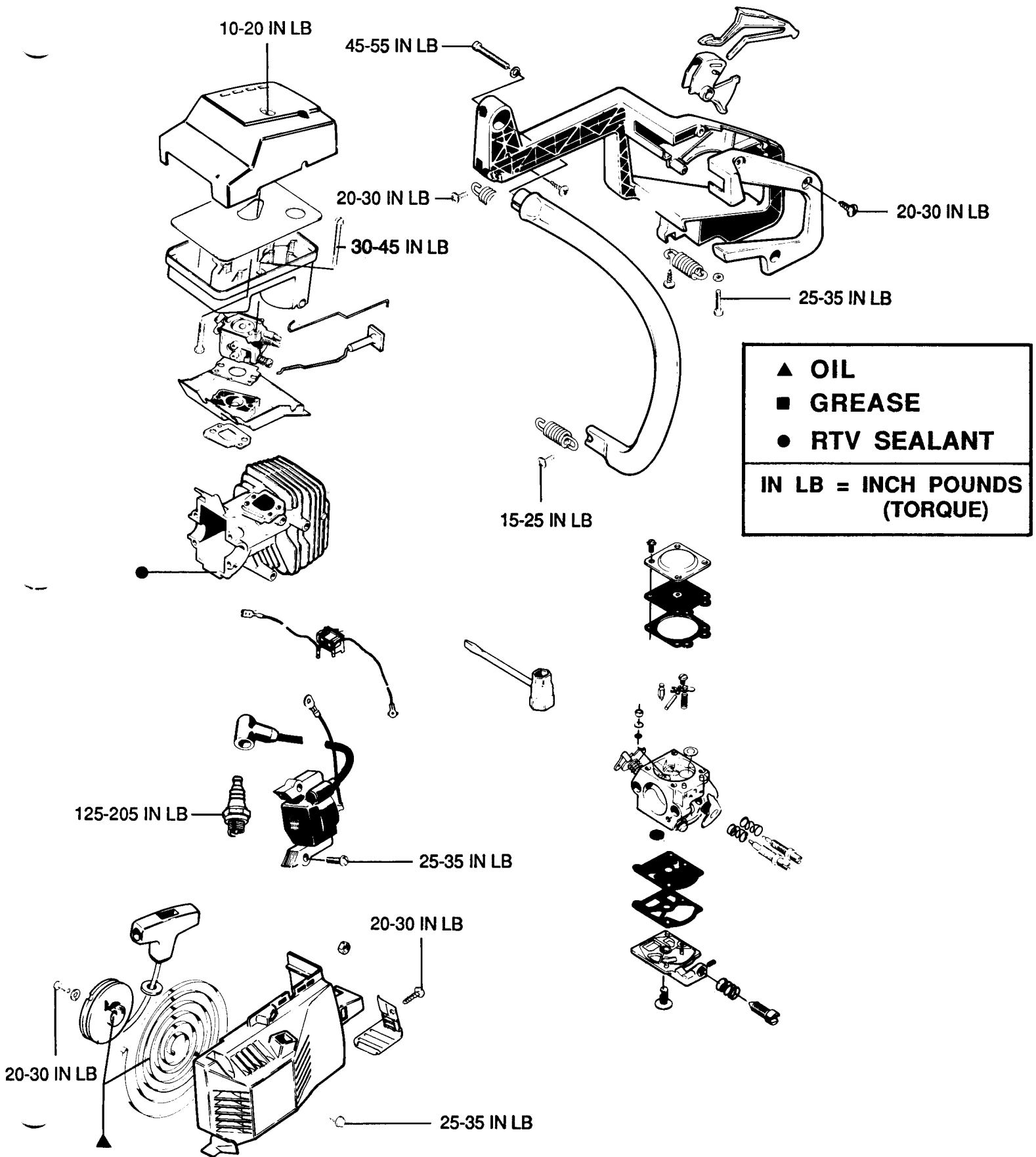

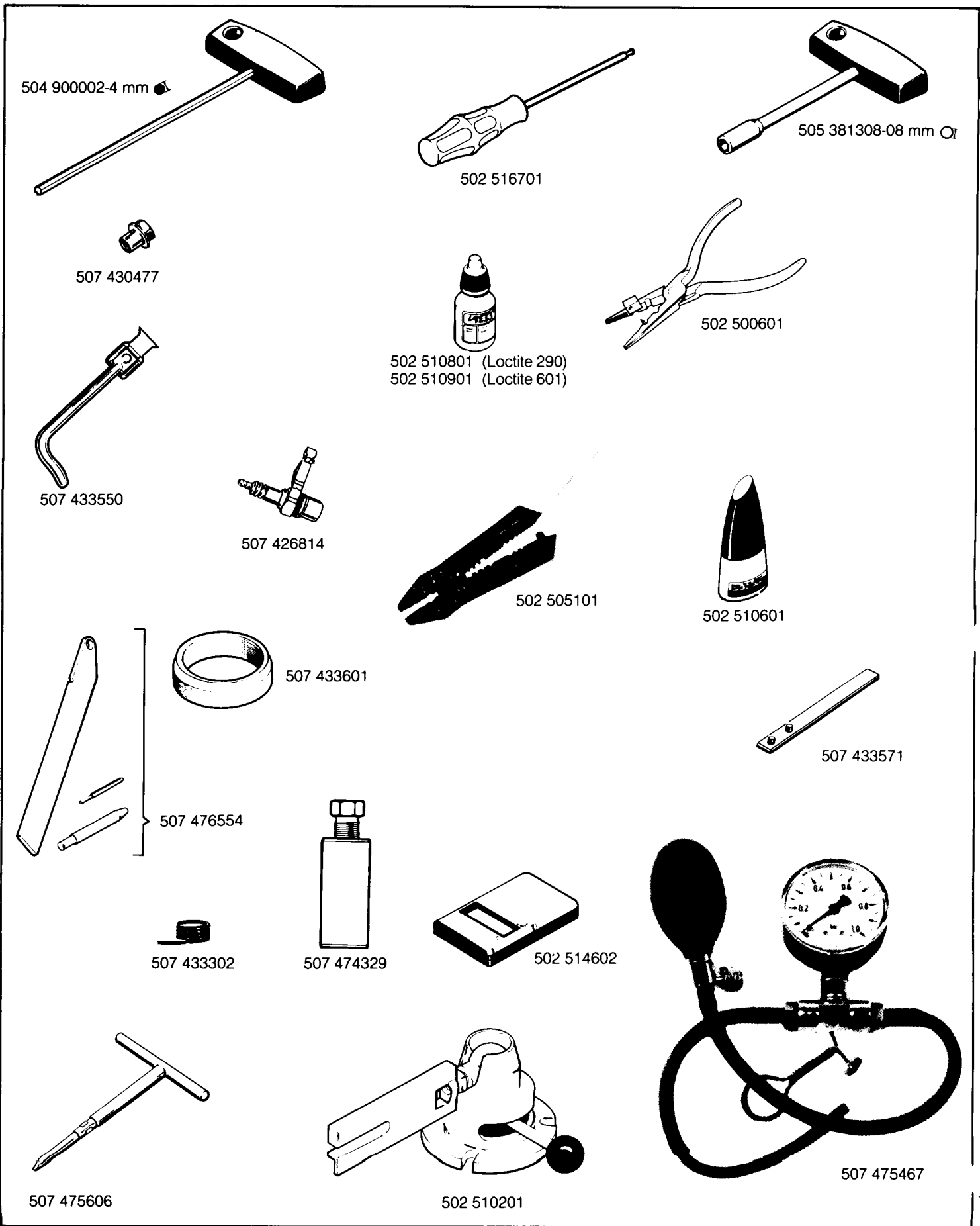





2 SERVICE TOOLS

PART	NUMBER	DESCRIPTION
502	500601	Assembly Pliers - Spark Plug Sparkie
502	505101	Wire Strippers
502	510201	Power Arm
502	501601	Nail Polish - Welch Plug
502	510801	Loctite 290
502	510901	Loctite 601
502	514602	Digital Tachometer
502	516701	Torx Screwdriver
502	900002	4mm Allen Wrench
505	381308	Socket Spanner
505	426814	Test Plug
507	430477	Thread Protector
507	433302	Wire Worm Adaptor
507	433550	Piston Stop
507	433571	Clutch Wrench
507	433601	Brake Band Ring
507	474329	Worm Gear Remover
507	475467	Pressure Pump
507	475606	T-Screwdriver
507	476554	Brake Tool Kit

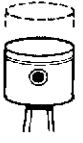
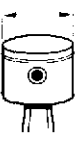
3 TECHNICAL SPECIFICATION

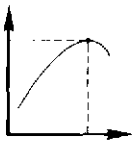
ENGINE

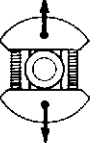
					
Displacement cc cu.inch	Bore Ø mm inch	Stroke mm inch	Max power of speed rpm	Idling speed rpm	Engagement rpm
34 2.1	36.5 1.43	32.5 1.28	8000	3000	4200

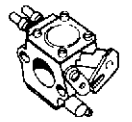
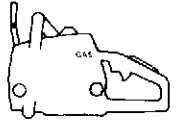
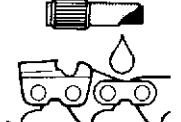
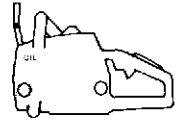
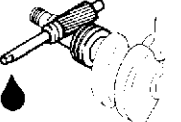

FUEL - AND LUBRICATION SYSTEM

					
Carburetor L= 1 H= 1	Fuel tank volume litre US. pint	Oil pump capacity cc/min	Oil tank volume litre US. pint	Automatic oil pump	
Walbro WT-67	0.3 .63	4.0 6000 rpm	0.15 0.31	Gear type positive displacement	

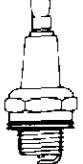
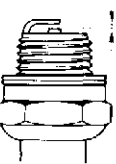
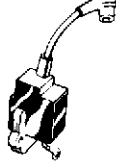
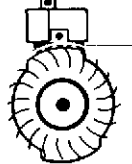
IGNITION SYSTEM

					
No load free speed rpm		Spark plug Champion	Electrode gap mm inch	Ignition system	Air gap mm inch
12,000		RCJ 7 Y	0.6 .024	CDI PHELON	0.3 .012

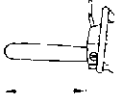
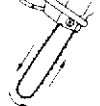
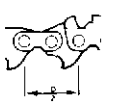
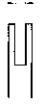
BAR AND CHAIN

					
Bar length inch cm	Chain speed m/sec	Chain pitch inch	Drive link gauge mm inch	Weight kg lbs	Weight with guide bar and chain kg lbs
13", 15", 16" 32, 38, 40	15.0	0.325	1,5 .058	4,9 10.80	5,25 11.25 (13")

WEIGHT

A. CHAIN BRAKE

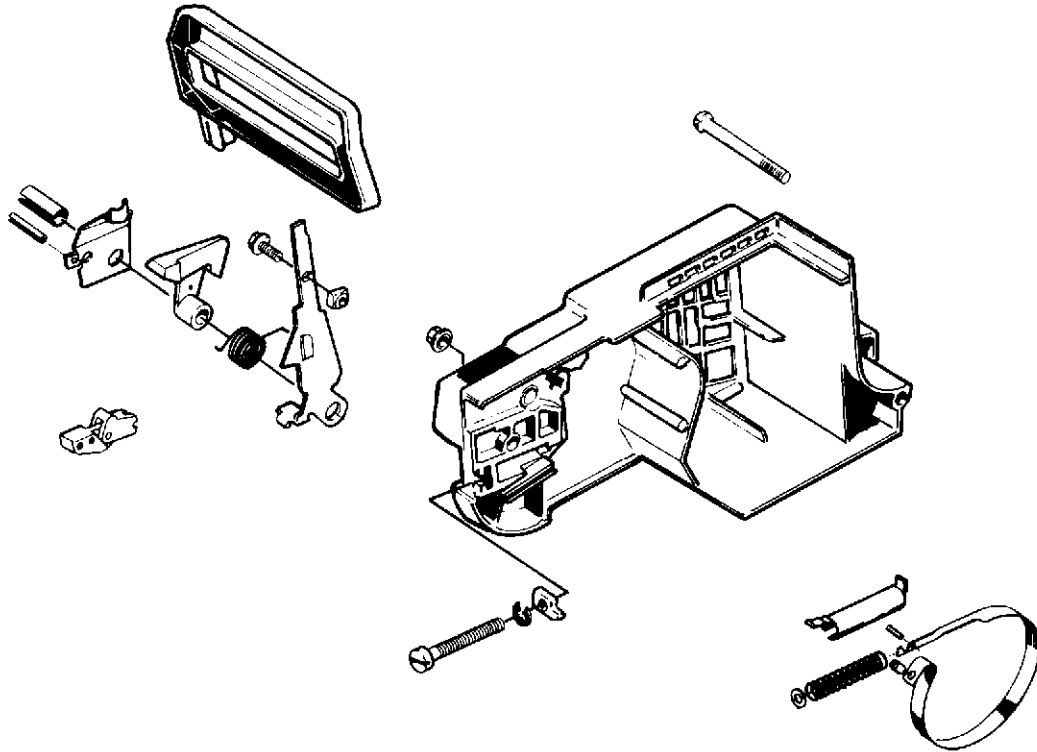

- Release the chain brake by pulling back on the handguard. Remove the guide bar clamping nut and rear screw. Remove the clutch cover and clean the chain brake mechanism.

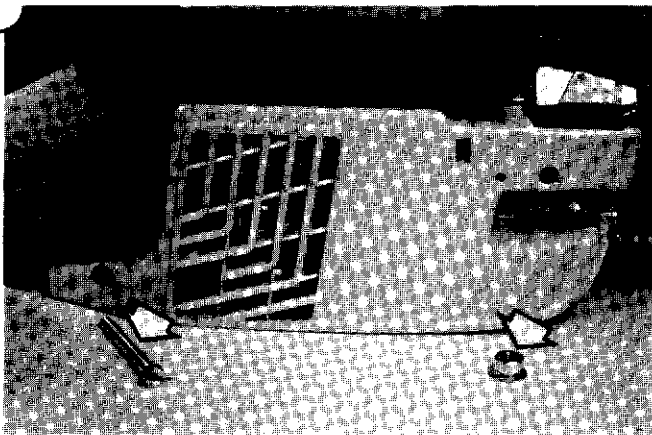

- Pull back on the handguard to fully release brake band tension. Insert the band ring-tool.

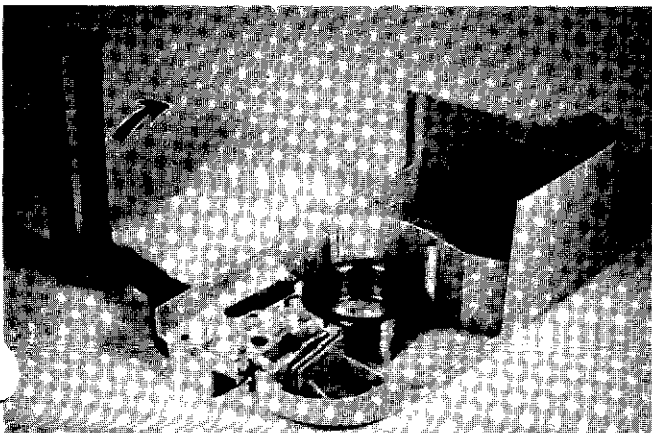

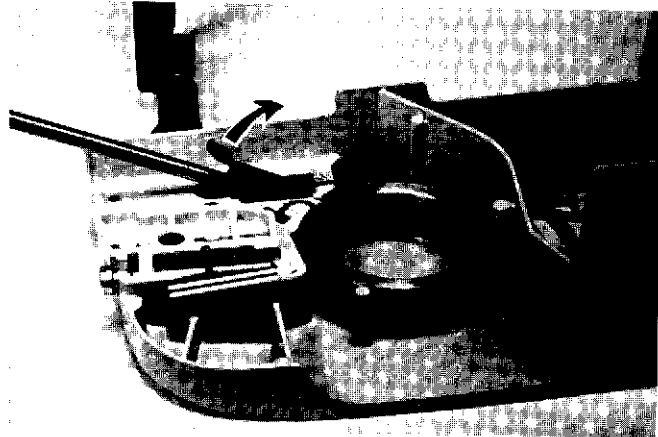

- Allow the handguard to return to the "run" position
Remove the brake spring cover by prying up with a screwdriver blade.

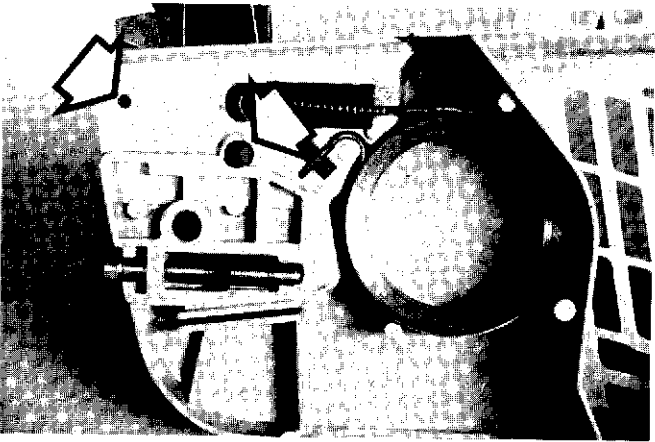

- Using the suitably sized drifts (supplied in the brake repair kit) remove both the large and small diameter roll pins.

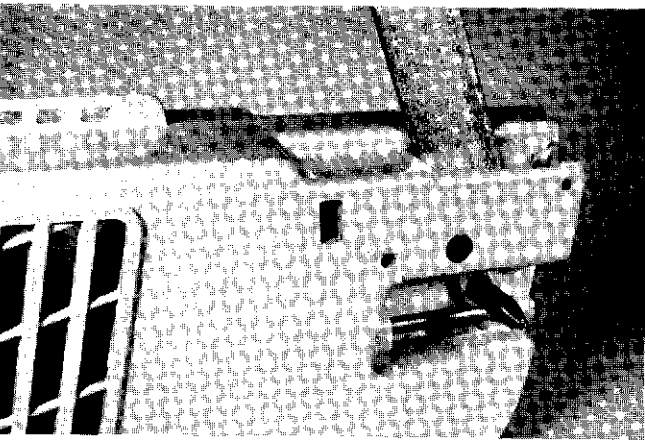

- Insert the brake tool (as shown), using the large diameter drift as a pivot pin in the clutch cover mounting bolt hole.

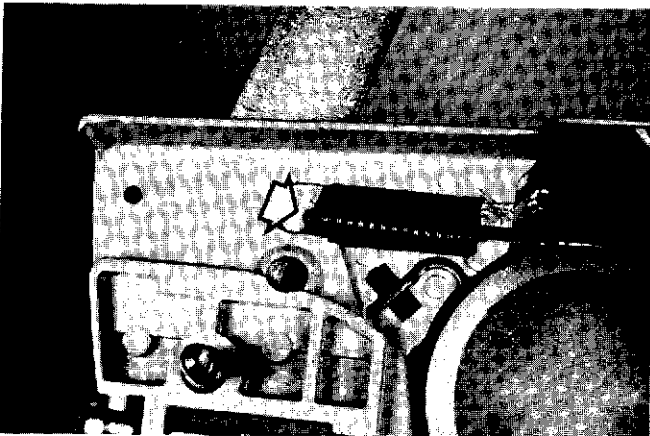

- Position the notch in the brake tool against the roll pin in the brake band.

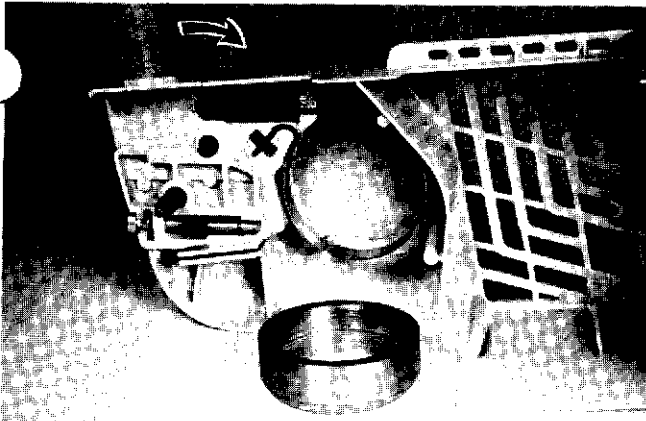

- Pull back on the brake tool to release tension on the brake ring-tool. Remove the ring-tool and allow the brake band to return to the static position. Remove the brake tool and drift.

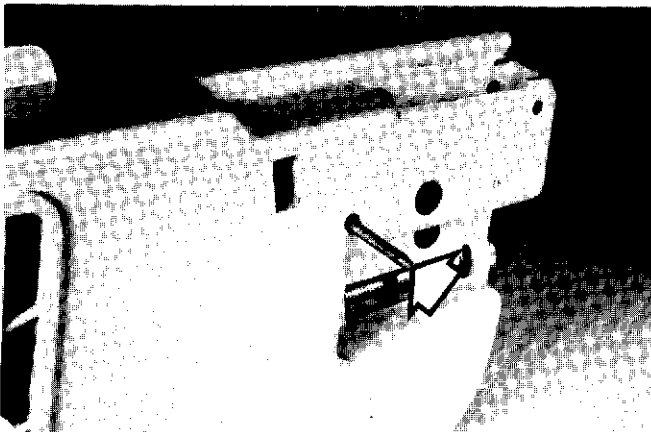

- Using a small diameter drift (through the access hole on the outside of the clutch cover) tap out the brake band anchor pin. Remove the brake band.

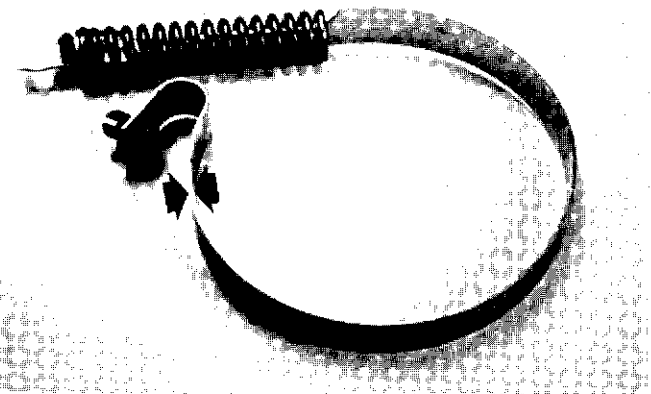

- Check the brake band for wear. Replace the band if worn to less than .020" thickness at the point of heaviest wear. Clean and check all brake parts for wear or damage.

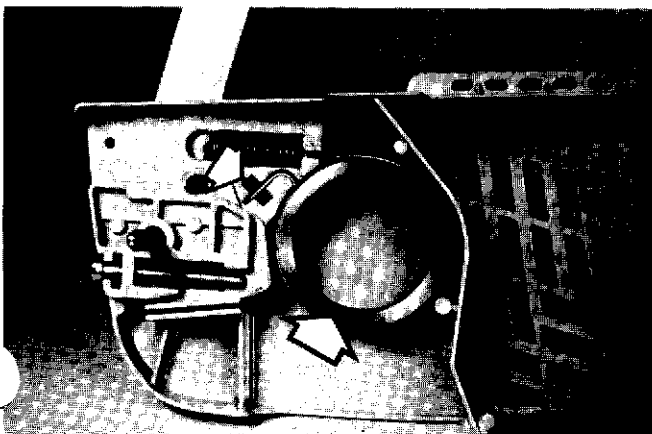

- Lubricate the brake spring with grease. Install the brake band and spring. **⚠ NOTE:** Position the (band anchor) roll pin with the slot facing up in the casting pocket, to ensure secure installation. Using the brake tool to enlarge the band opening, insert the ring-tool to retain the brake band.

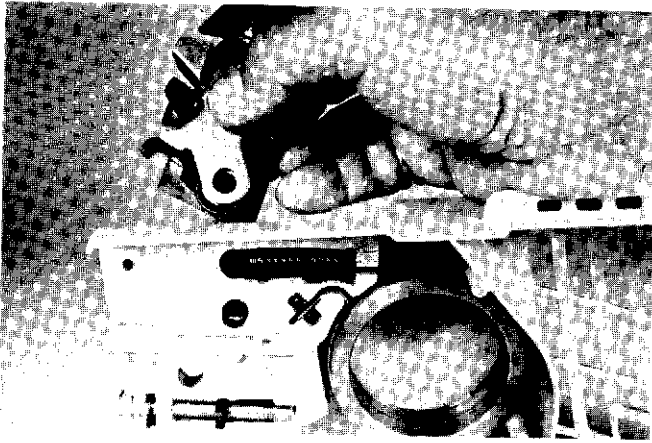

- Remove the band tool. Lubricate the components of the brake mechanism with oil or grease. Holding the handguard, position all the other components against it.

Carefully insert the complete assembly as shown.

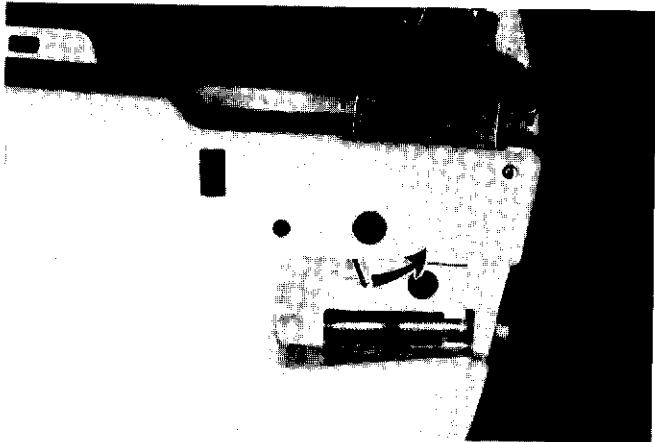

- NOTE: Be sure the tang of the tension spring is in place on the casting ledge.

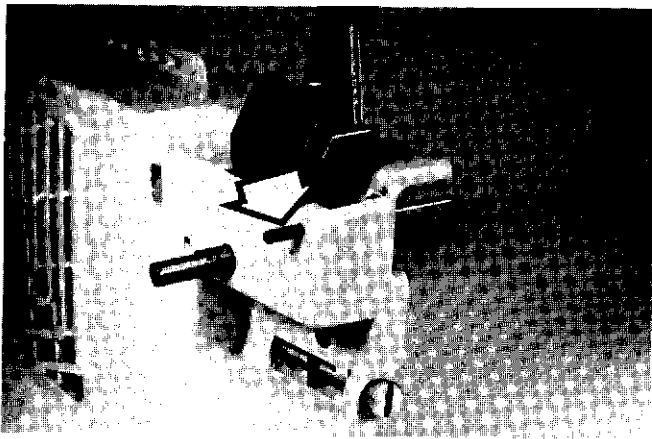

- Using the large and small diameter brake kit drift, as pilot pins, center the brake mechanism and knee-link, position the small diameter roll pin with the slot facing the top of the casting and tap into place (flush with the face of the casting). NOTE: Be sure the knee-link hole is centered by the small diameter drift.

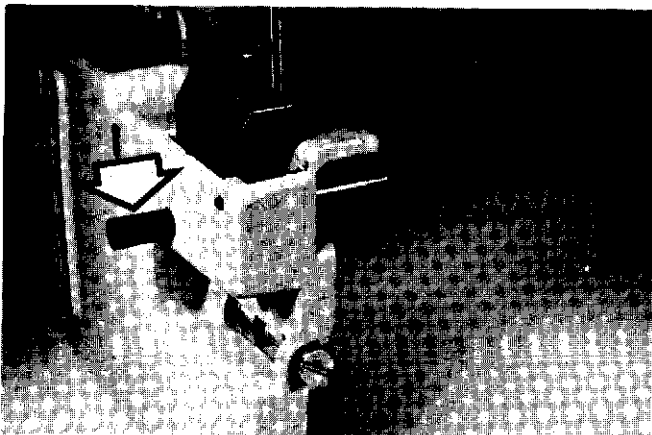

- Position the large diameter roll pin (with the slot facing the **top** of the clutch cover) and tap into place flush with the casting face. To connect the knee-link to the guide pin on the brake band, pull back on the hand guard and insert the stamped end of the brake band into the slot in the knee-link. The roll pin will nest in the molded notch in the elbow.

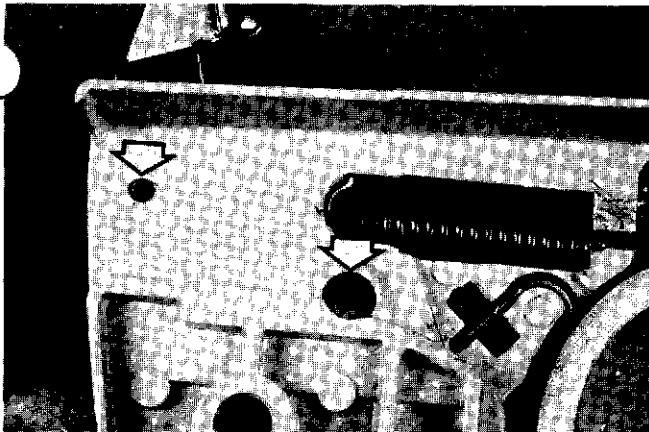

- NOTE: The grooves (slot) in the roll pins must face upward toward the top of the casting as shown.

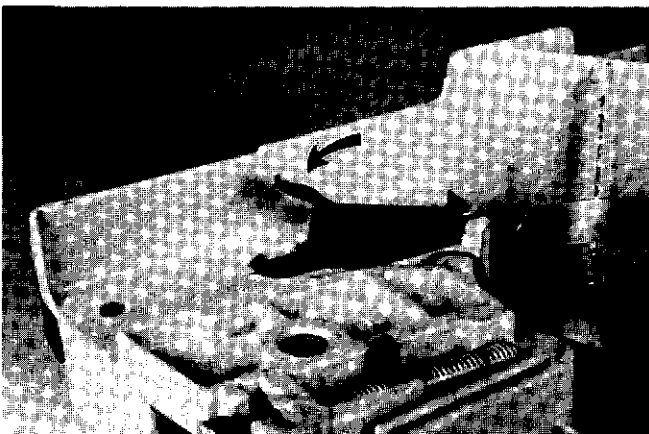

- Be sure the brake band spring has been greased, and firmly press the spring cover into the nest provided in the casting.

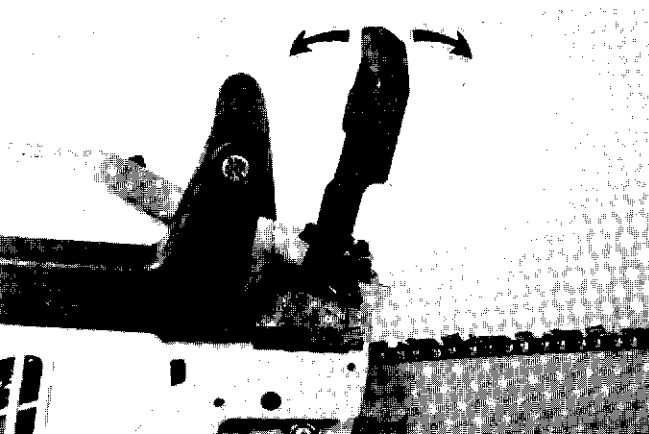

- Install the bar, chain and clutch cover. NOTE: Fire the brake to "center" the brake/clutch drum before tightening the guide bar mounting nut and rear fastener screw. Check the mechanism 2-3 times through the "set" (full back) / "run" / "fire" positions.

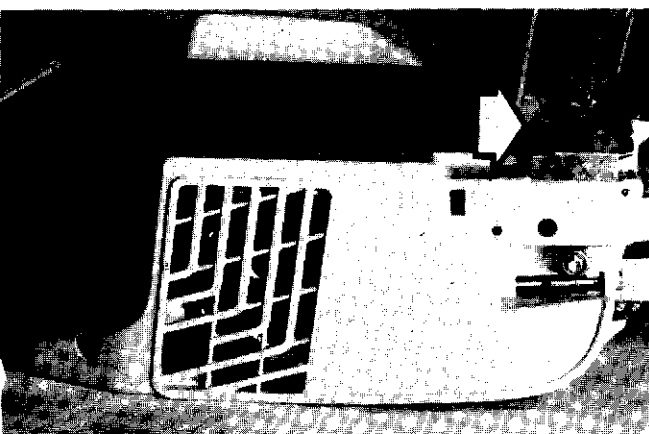

- Set the brake and place the handguard in the "run" position. Push the inertia weight forward; upon release the weight must return to the rest position. NOTE: When a force of 4.5-11 pounds is applied to the upper part of the rear edge of the weight, the chain brake must fire.

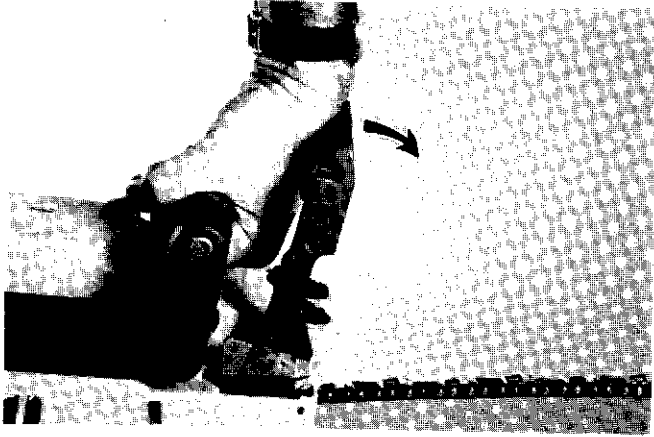

- Check the brake function as follows:
 1. Place the saw on firm, level ground.
 2. Start the engine and advance the speed to full throttle.
 3. Holding the saw firmly, fire the brake by pressing the left wrist against the handguard as shown. The chain must stop immediately.

B. THROTTLE CONTROL LOCKOUT

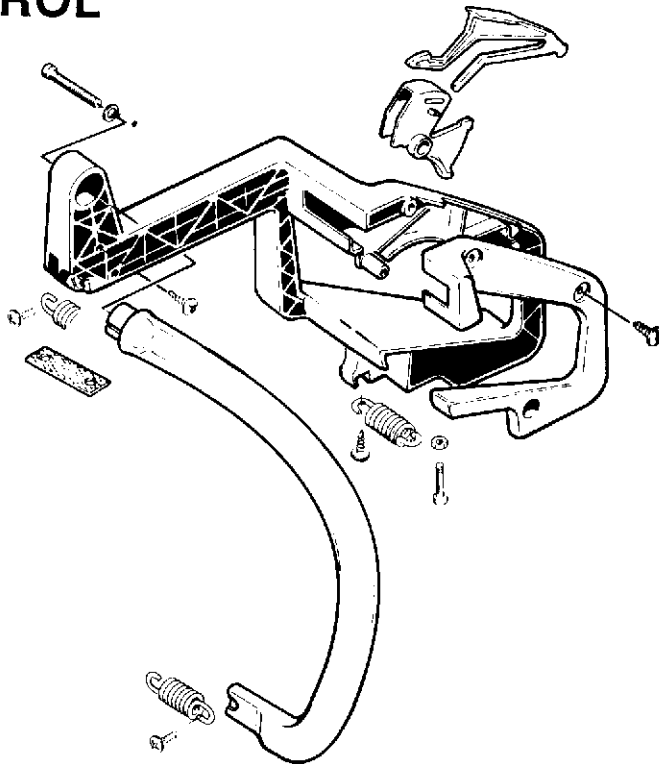

- Using the thin-edge tool, pry the on/off switch out of the rear handle casting. Disconnect the two flag terminals.

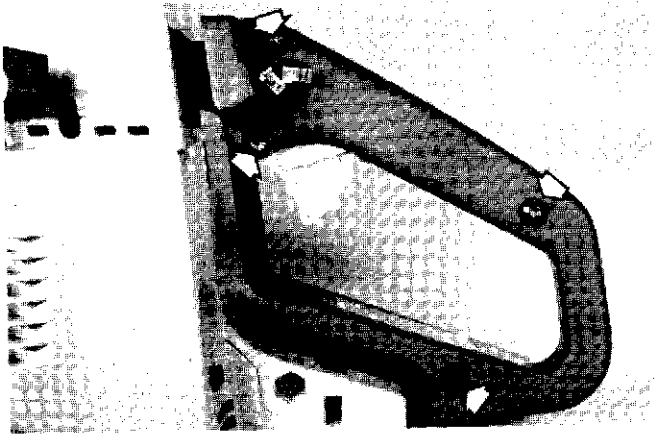

- Remove the four handle cover screws and lift off the cover to expose the throttle/throttle lockout mechanism.

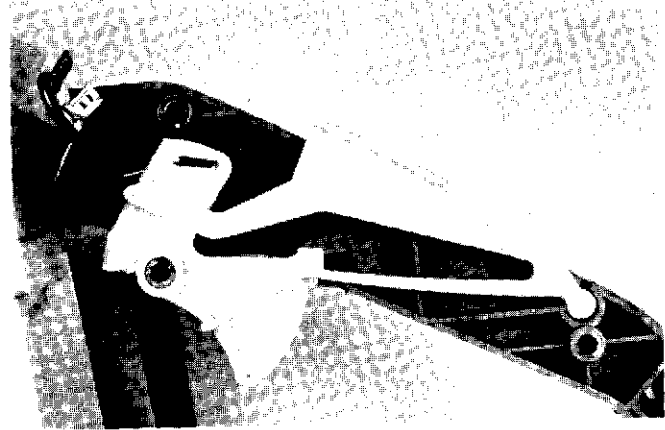

- Clean and check all parts for wear or damage.

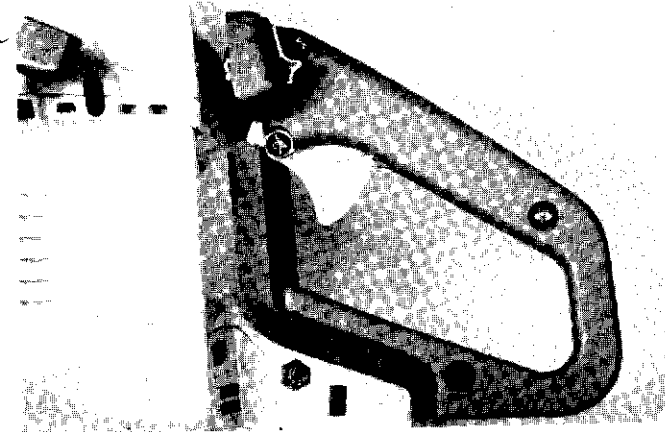

- Reassemble the mechanism, handle cover and screws. Torque the cover screws to spec. (see Section 2 Service Data). Connect the on/off switch flag terminals and snap the switch assembly into position.

NOTES

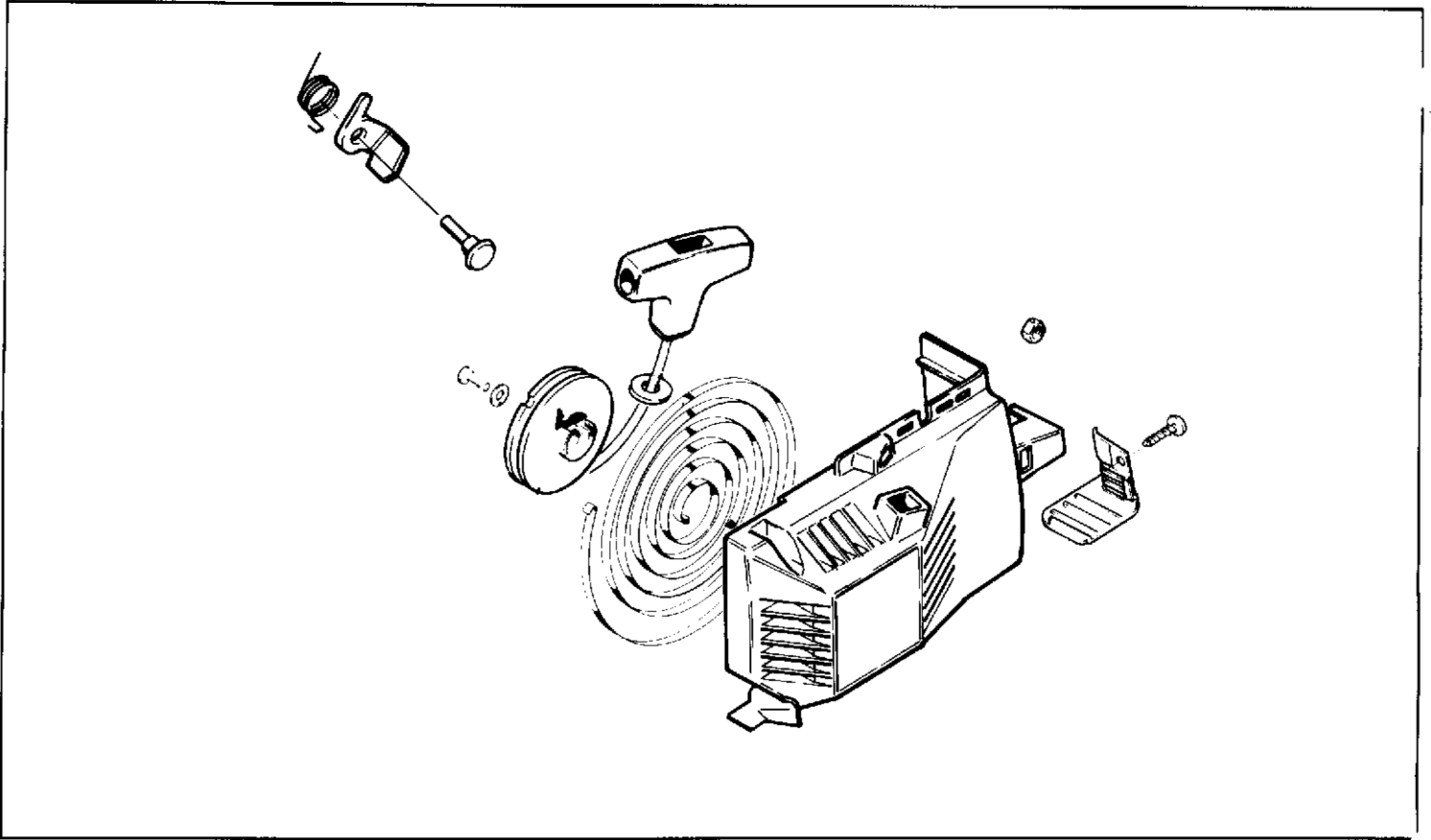

- Remove the clutch cover assembly.

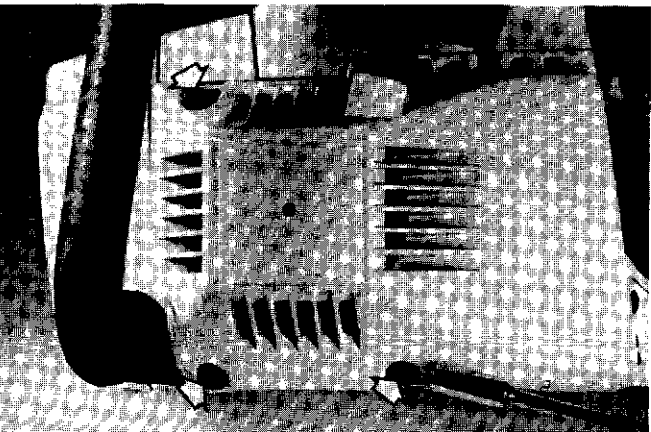

- Remove the three **side** screws securing the start-er assembly to the crankcase.

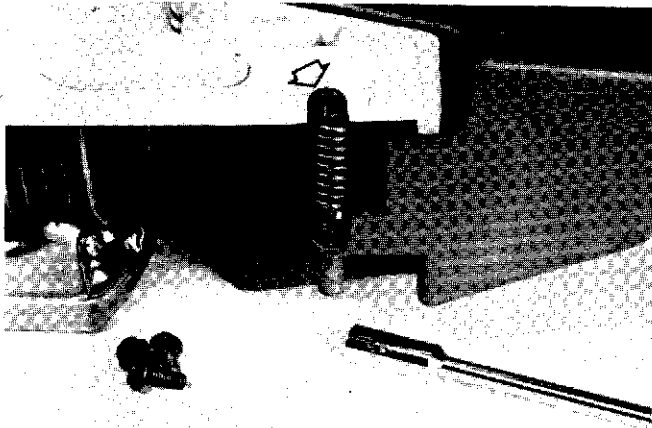

- Turn the saw on its side and remove the lower frame/starter housing shock mount screw.

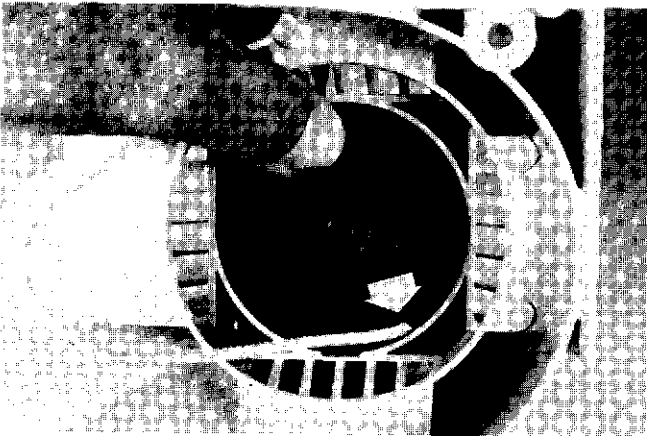

- Clean the starter housing and mechanism. Pull the starter rope out about 10-12". Using your thumb to resist pulley rotation, place the slack rope in the notch of the starter pulley and slowly unwind the starter tension until the rewind spring is fully relaxed.

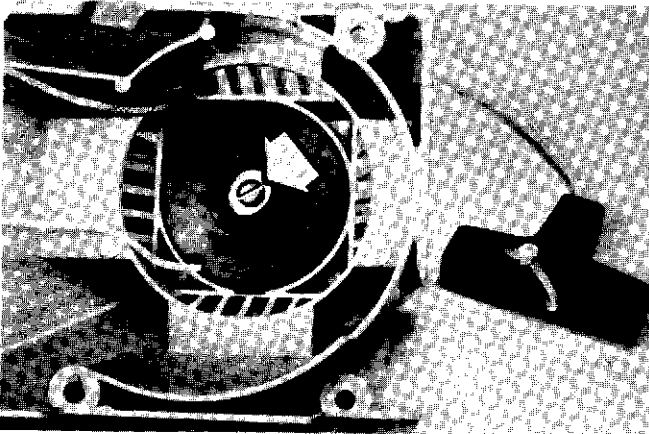

- Remove the pulley securing screw and washer. **Gently** move the pulley to ensure that the inner rewind spring anchor is disengaged. Lift out the starter pulley.

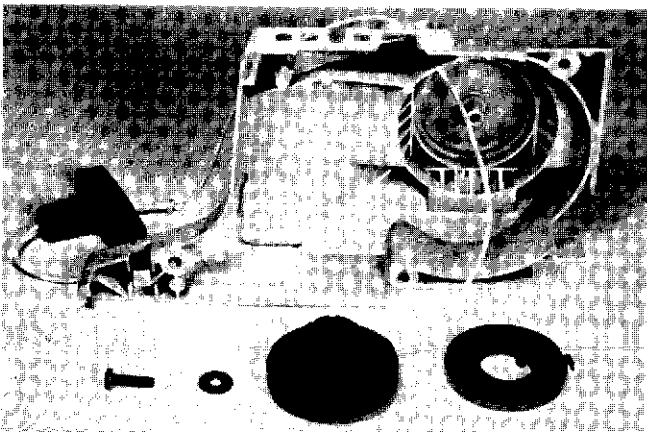

- Remove the rewind spring cassette. Clean and check all parts for wear or damage.

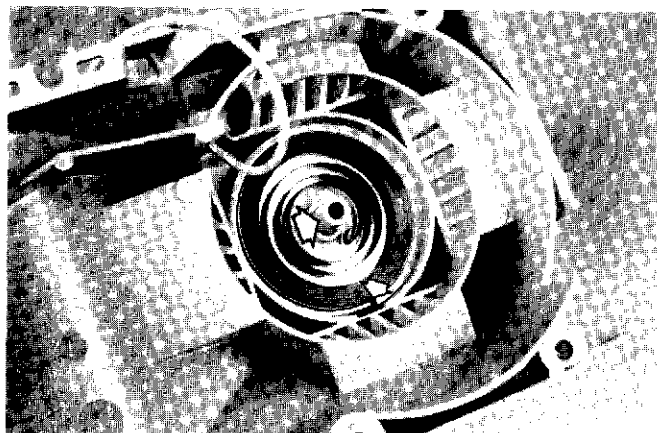

- Using a cold-resistant grease, lubricate the starter pivot pin (center post). Oil the rewind spring coils and insert the spring cassette (metal cup next to the casting).

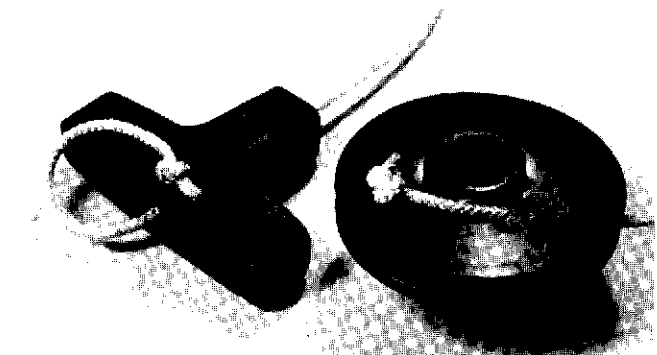

- Install a new starter rope. Be sure the pulley end knot nests in the pocket provided in the pulley. Use a small, non-slip "figure eight" knot (as shown) for both the handle and pulley ends of the rope.

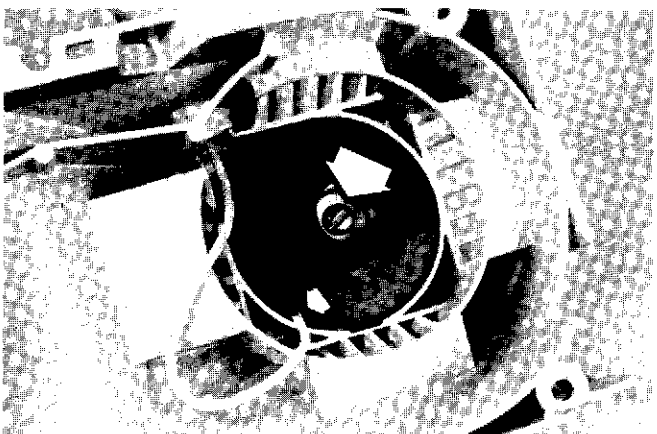

- Wrap the rope around the pulley. Gently place the pulley down over the center post to engage the inner spring anchor in the slot in the pulley. Install the center post screw and washer. Torque to spec (see section 2 Service Data).

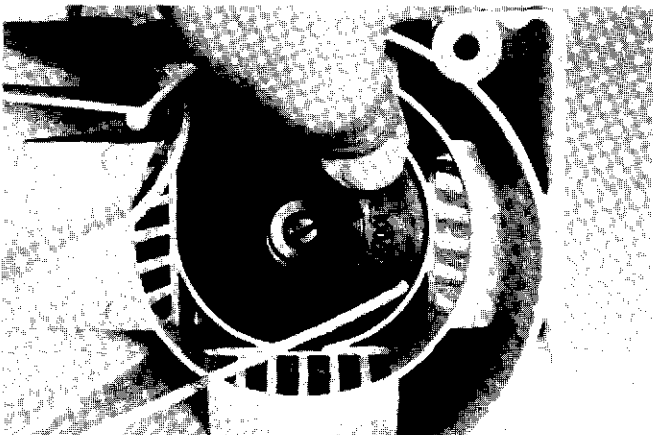

- Pull the starter handle to the full rope extension. Using your thumb to control the pulley, wind two turns pretension on the pulley and **slowly** let the rope rewind. **NOTE:** With the rope fully extended, be sure the pulley can be rotated at least 1/2 turn **more** before the rewind goes solid or "bottoms out". Check the starter mechanism for smooth operation and full return of the handle into the nest in the casting.

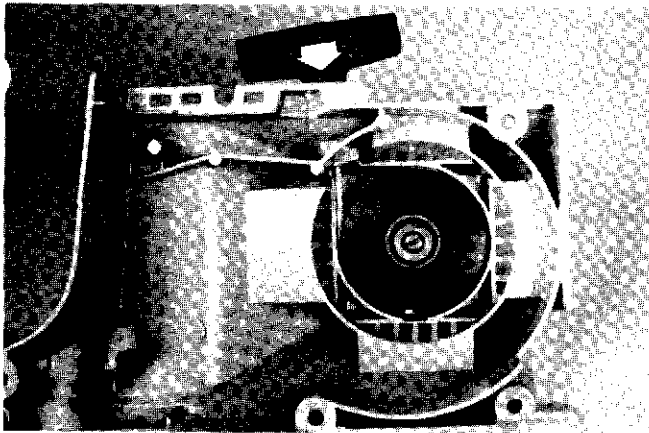

- Assemble the starter to the saw. NOTE: Apply loctite 242 to the screws.

NOTES

For Husqvarna Parts Call 606-678-9623 or 606-561-4983
6 ELECTRONIC SYSTEM

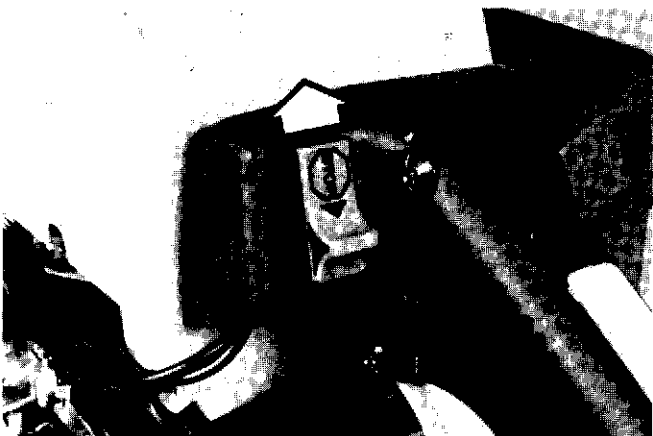
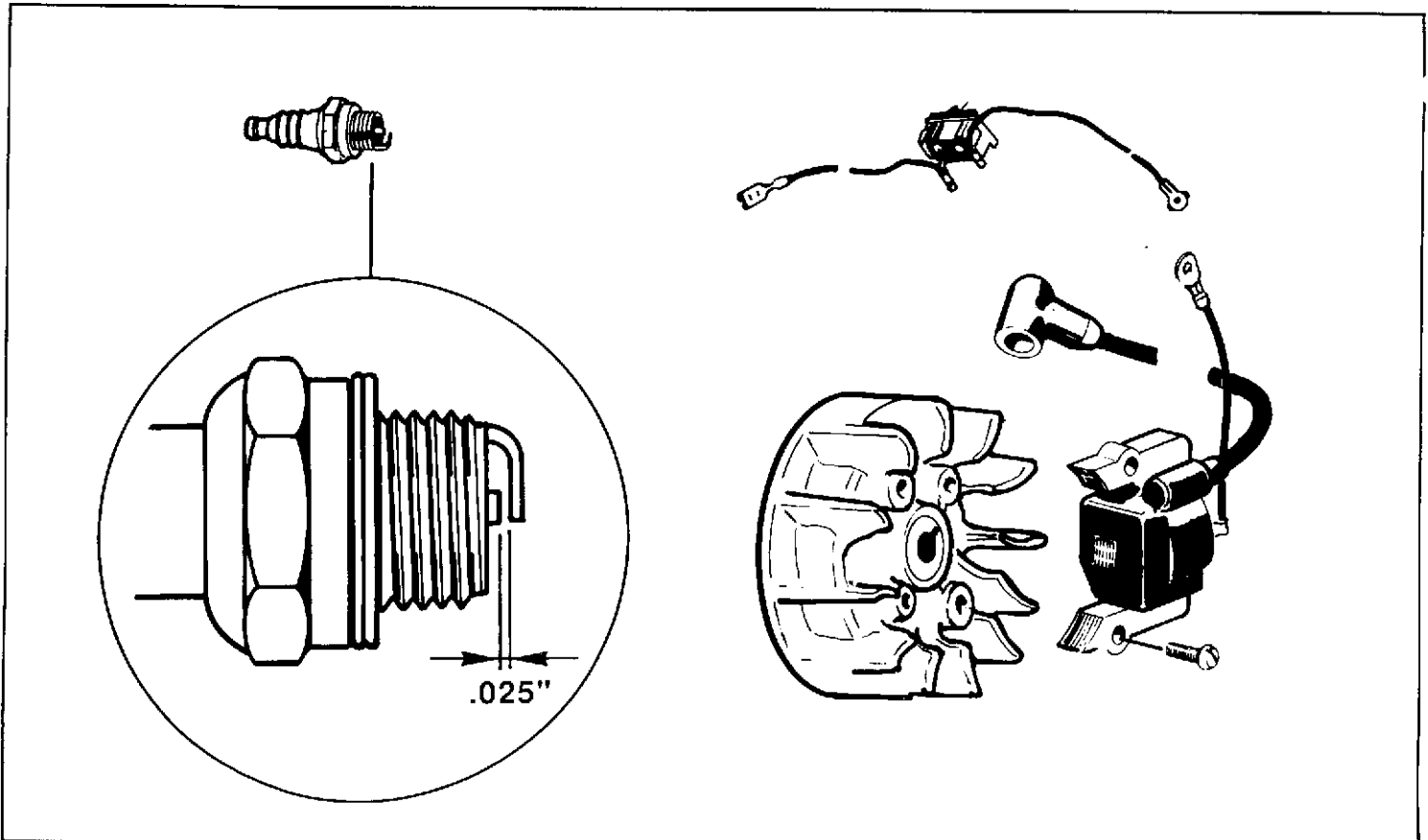

- Move the on/off switch to the "on" position.

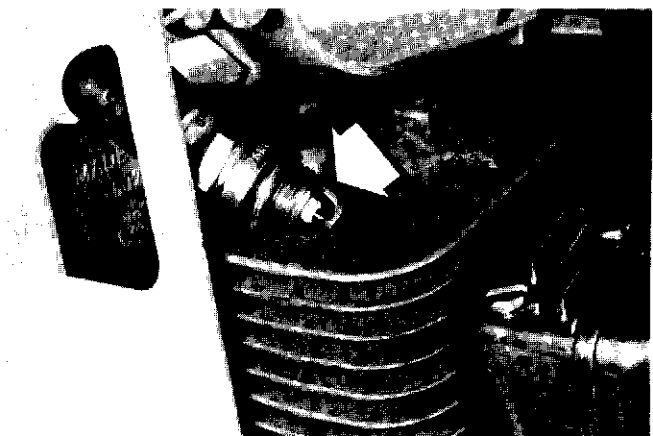

- Ground the spark plug against the cylinder fin as shown.

⚠ Insure the spark plug is routed well away from the spark plug hole in the cylinder and the exhaust outlet to prevent a fire from the escaping gases while turning the engine over. Rapidly pull the starter handle and watch for a spark between the spark plug electrodes. If there is no spark, try another spark plug.

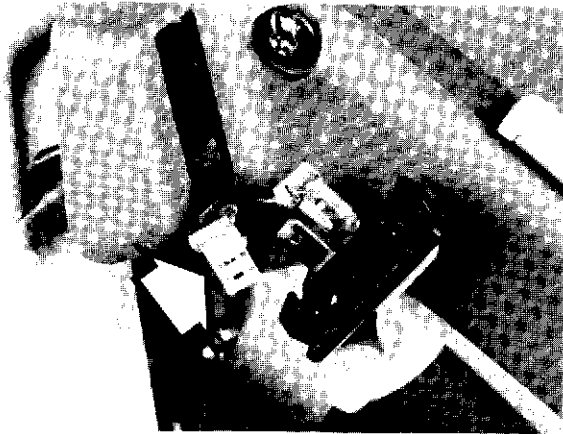

- If there is still no spark, disconnect the ignition switch wire from the on/off switch flag. Again, rapidly pull the starter. If spark is now observed, the problem is a faulty on/off switch assembly. Install a new switch assembly.

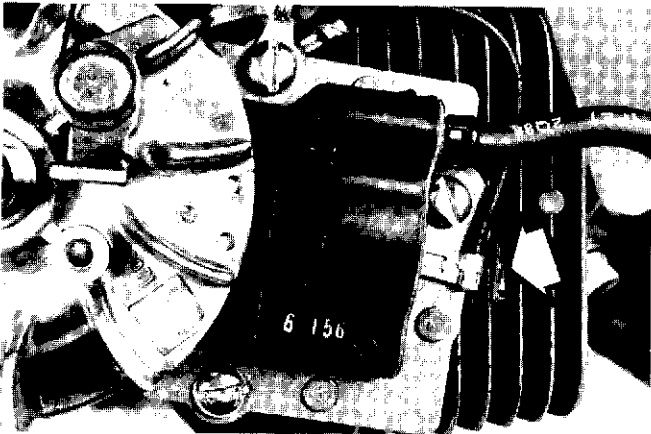

- If no spark is observed remove the starter assembly, disconnect the switch wire at the module and replace the starter (two screws should hold the starter in place while trying this procedure). Rapidly pull the starter. If spark is now observed the switch wire is at fault.

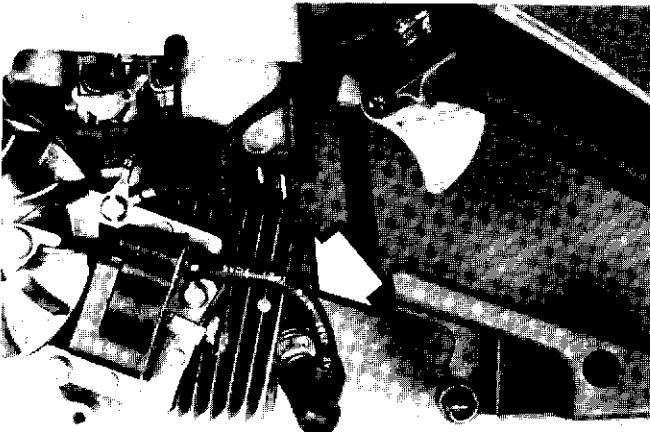

- If no spark is observed, check the high tension lead to the spark plug.

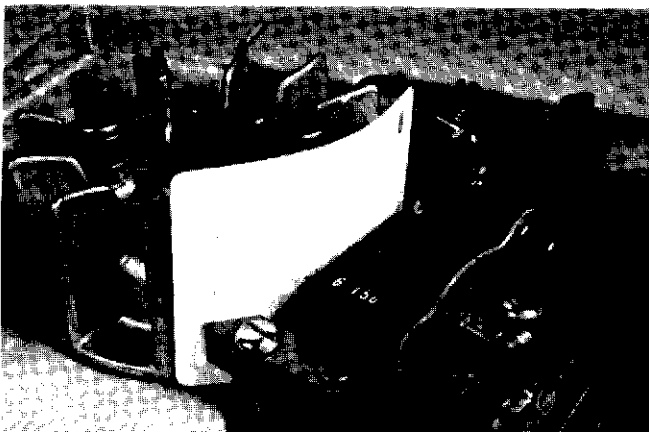

- Using the plastic air gap tool, check the air gap between the flywheel magnet and the ignition module laminates. The gap should be .012".

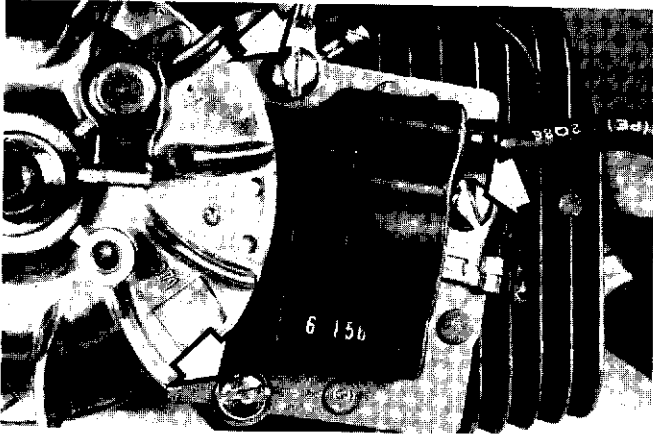

- To adjust the air gap spec., loosen the 3 laminate mounting screws shown. NOTE: These screws should have loctite 242 applied during assembly.

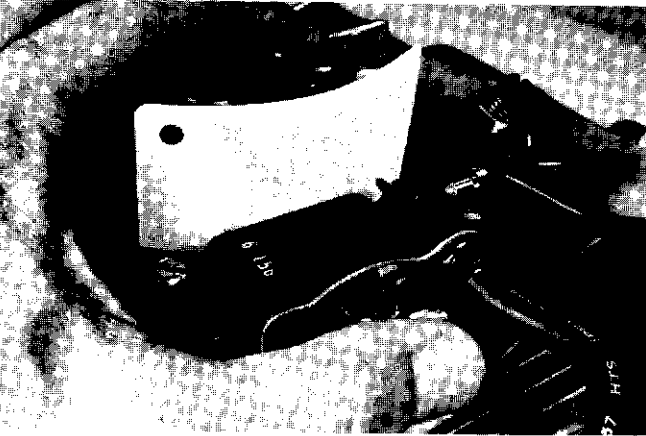

- Insert the air gap tool between the flywheel magnet and the ignition module laminates. Press the module against the flywheel and tighten the module mounting screws. Check for spark. If no spark occurs, and the flywheel's magnetic flux appears adequate, replace the ignition module.

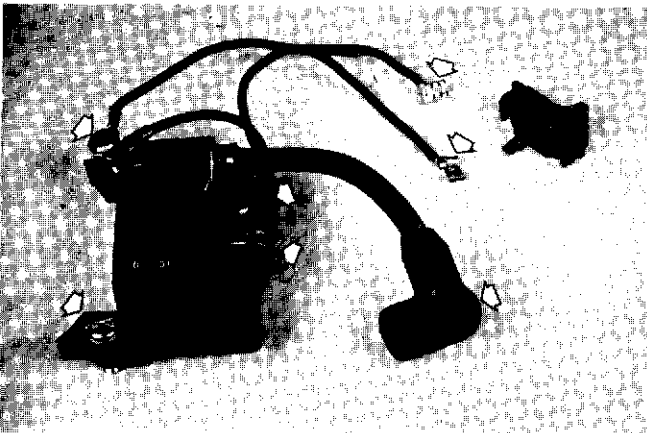

DISASSEMBLY

- Disconnect the spark plug lead and the on/off switch wires. Remove the 3 module mounting screws.

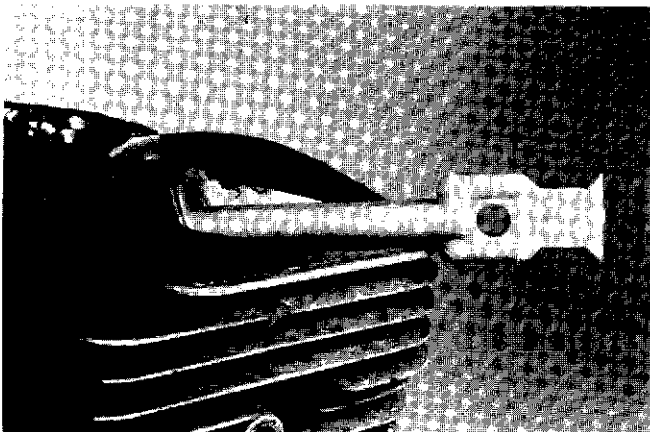

- Remove the spark plug and insert the piston stop tool as shown.

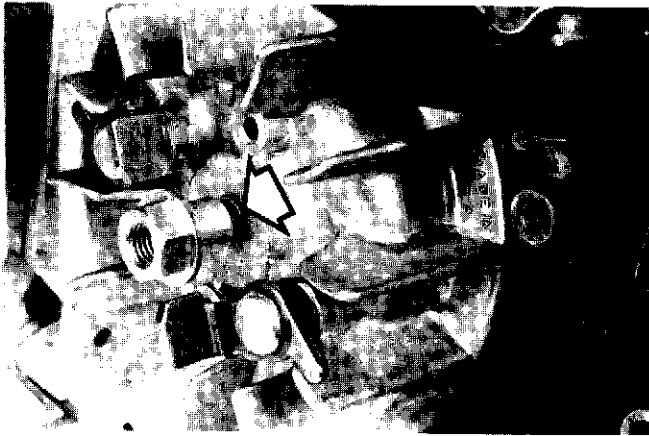

- Thread the flywheel knock-off nut on the crankshaft to within approximately 3/16" of touching the flywheel face.

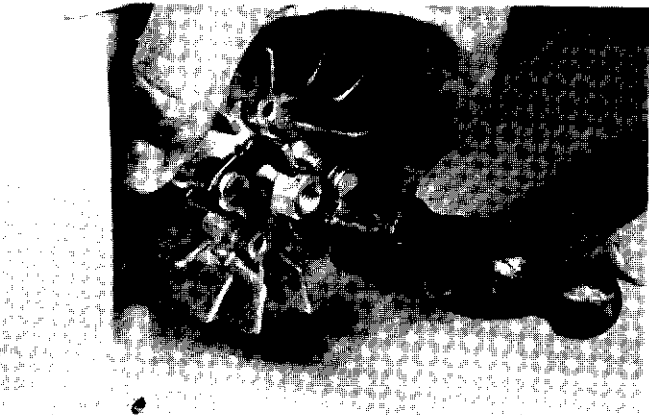

- While applying a slight outward tension on the flywheel, tap the knock-off nut to "pop" the flywheel off the crankshaft taper.

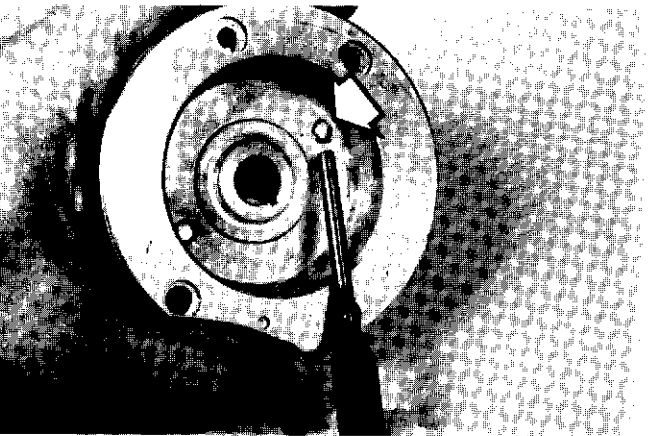

- Using a suitable size drift, drive out the pawl pivot pins to allow for the replacement of either the pawls or the pawl springs.

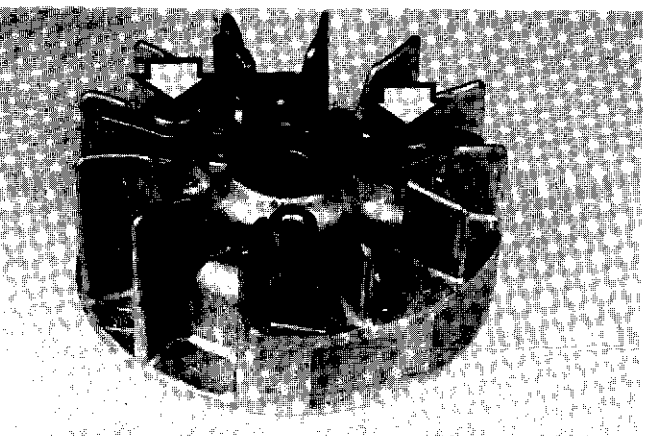

ASSEMBLY

- Install the new pawls and pawl return springs. Be sure the pawl pivot pins are bottomed and still allow free movement of the pawls.

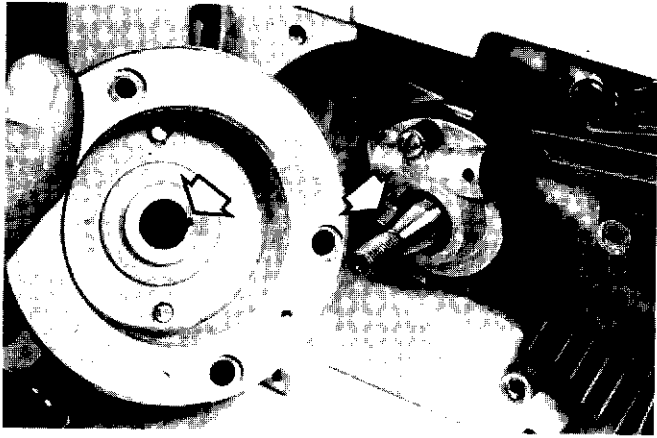

- Clean and check the taper on the crankshaft and in the flywheel hub. CAUTION: Be sure these tapers are dry and free from oil or grease.

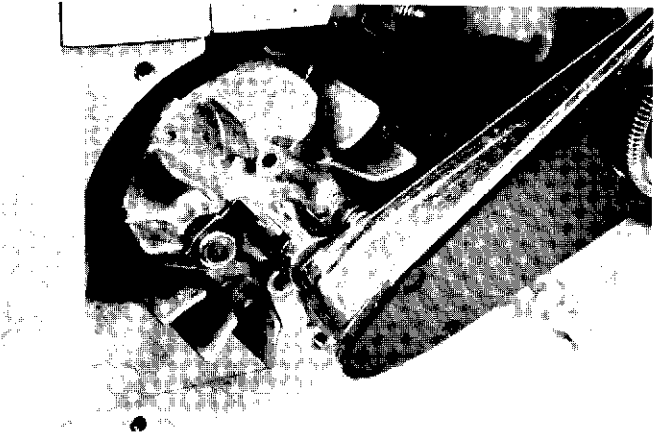

- Install the flywheel nut and torque to spec. (see Section 2 Service Data).

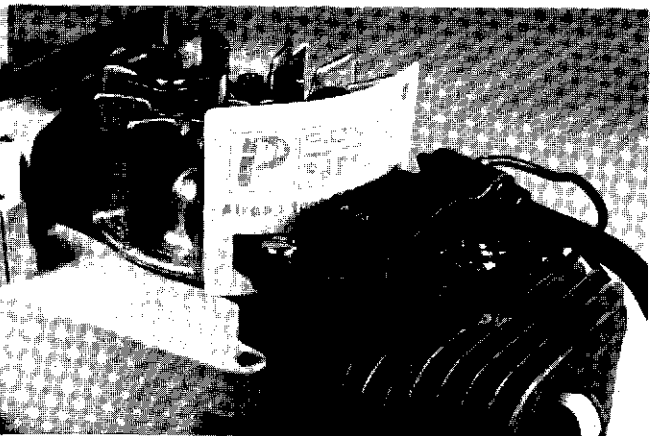

- Install the ignition module laminate and, using the air gap tool, check the gap between the flywheel magnet and the module laminate. Set at .012" as shown earlier in this section. NOTE: Use loctite 242 on the mounting screws.



- Check that the ignition switch/module wire and the ground wire connections are secure at the module end. Be sure both wires are nested in the notch provided in the edge of the insulating block.

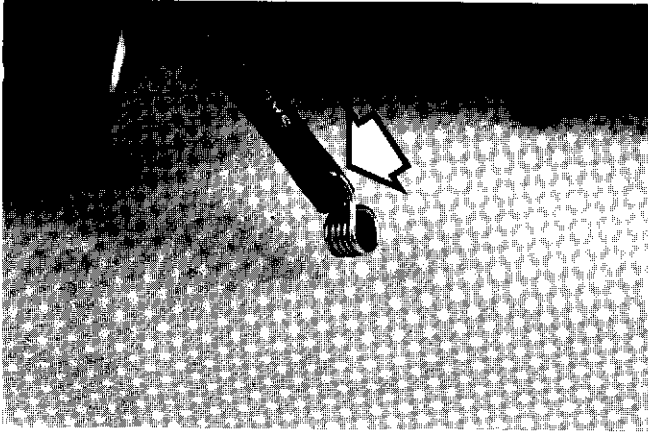

- Check to ensure that the high tension lead "sparky" wire is piercing the wire core in the lead. Insert the sparky wire/lead into the rubber sparky cover.

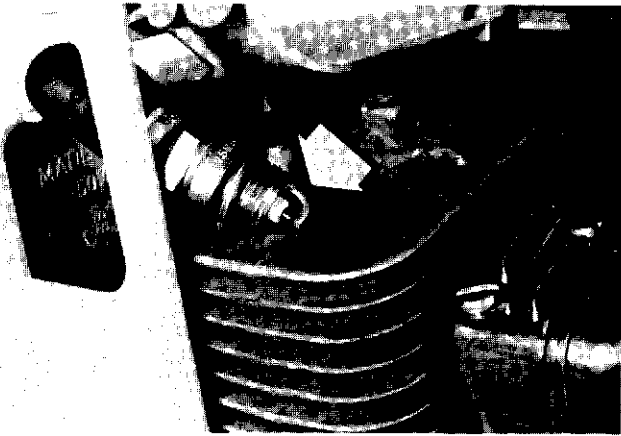

- Install the starter and check for spark as described earlier in this section.

NOTES

For Husqvarna Parts Call 606-678-9623 or 606-561-4983

7 CENTRIFUGAL CLUTCH

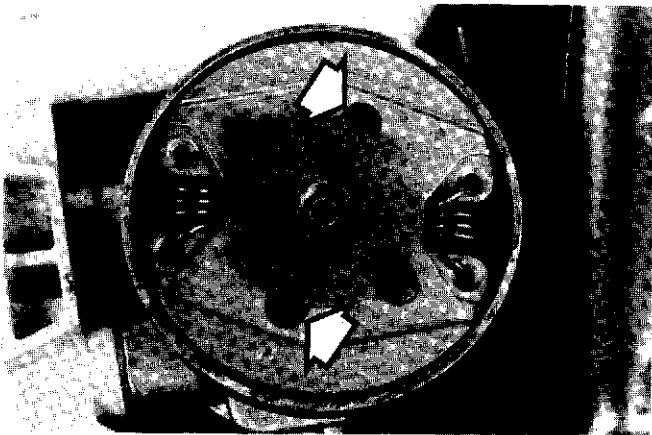
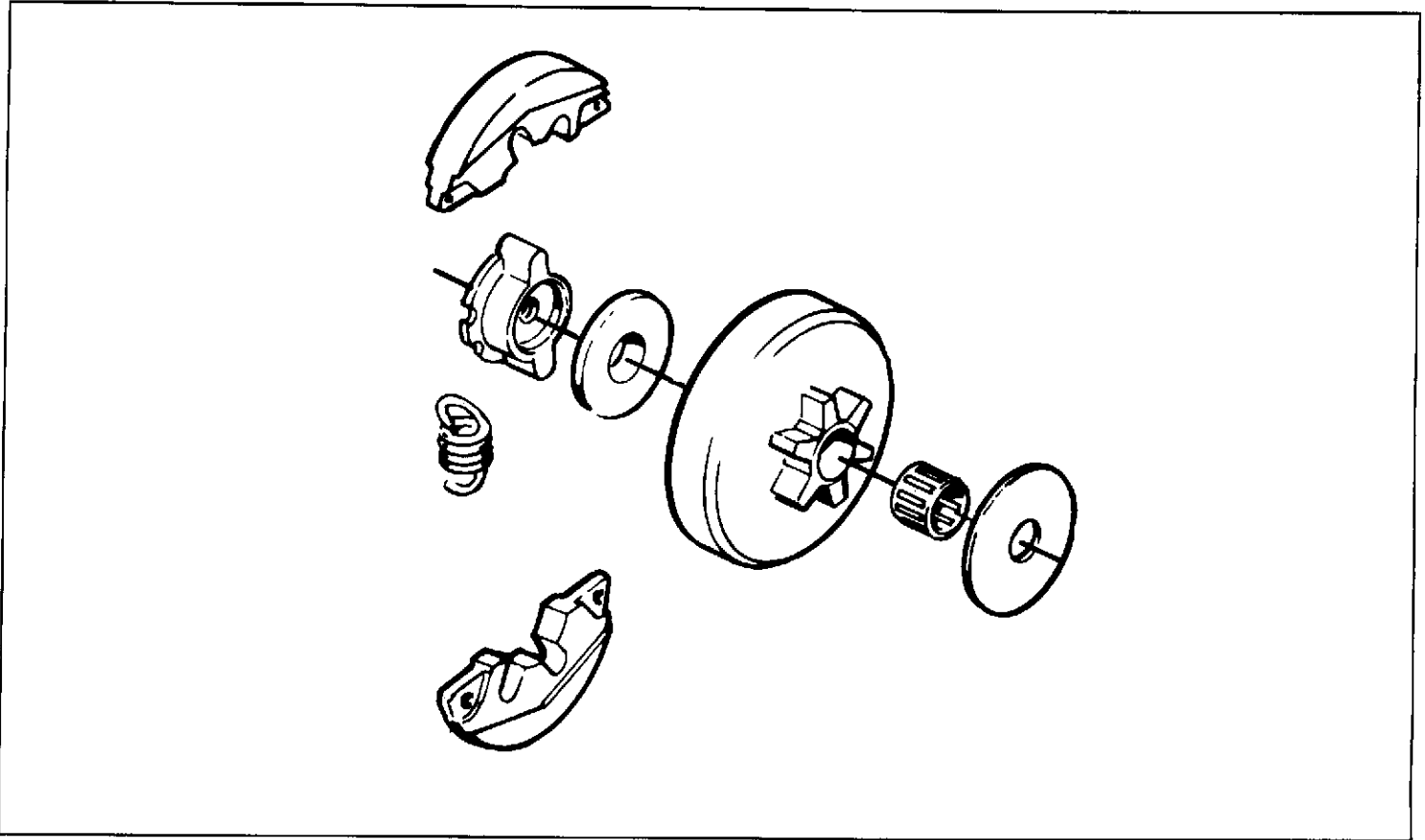

- Install the piston-stop tool. Remove the clutch assembly by tapping on a drift placed against one of the two knock-off holes provided. Tap in the direction stamped on the clutch driver face.

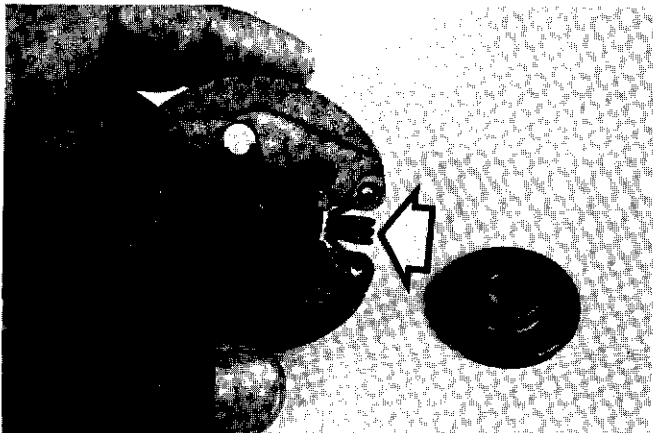

- The clutch assembly consists of a "top hat" washer, a driver, two shoes and two springs. NOTE: The correct spring position is as shown to ensure that the springs do not touch the clutch drum.

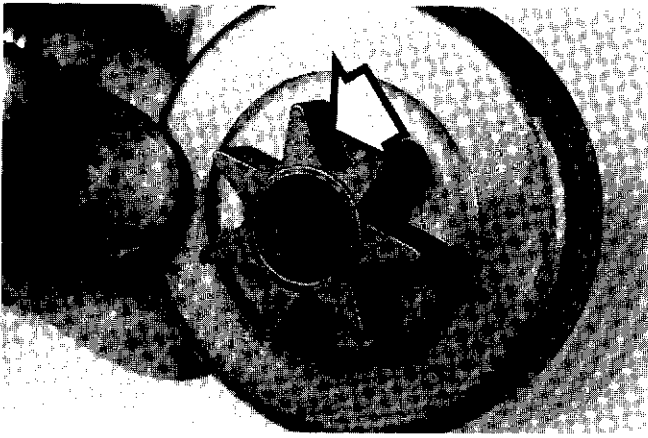

- Check the clutch drum drive sprocket for wear. A worn sprocket changes the "pitch" of the teeth and can cause premature chain failure.

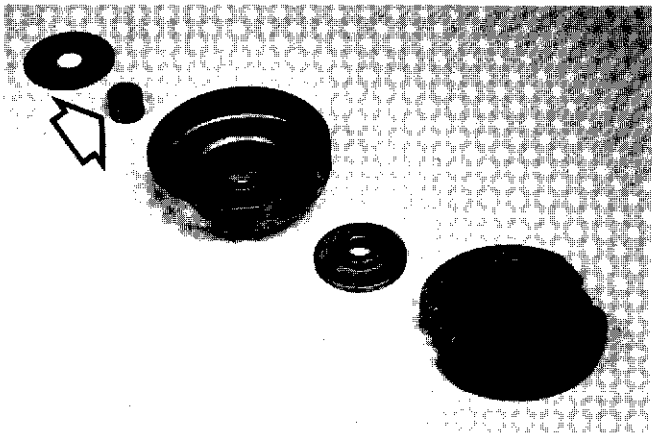

- Assemble the clutch drum and clutch in the order shown. NOTE: Be sure to lubricate the clutch drum bearing to prevent chain drag at idle speed.

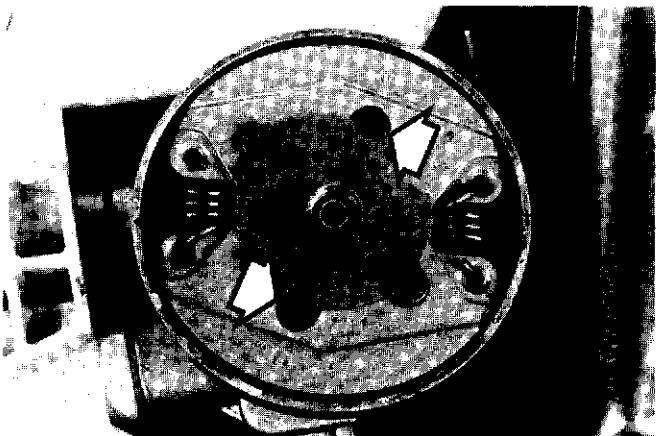

- Spin the clutch assembly onto the crankshaft and tighten by tapping on a drift inserted in one of the holes provided in the clutch driver. CAUTION: Do not start the engine without the guide bar, chain and clutch cover in place.

NOTES

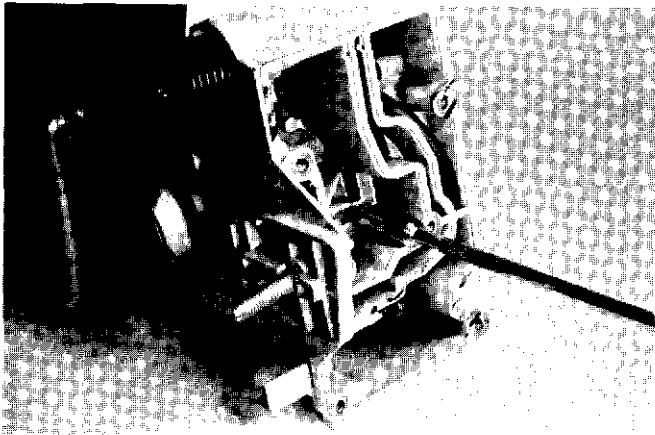

- Remove the 4 screws securing the fuel/oil tank to the crankcase.

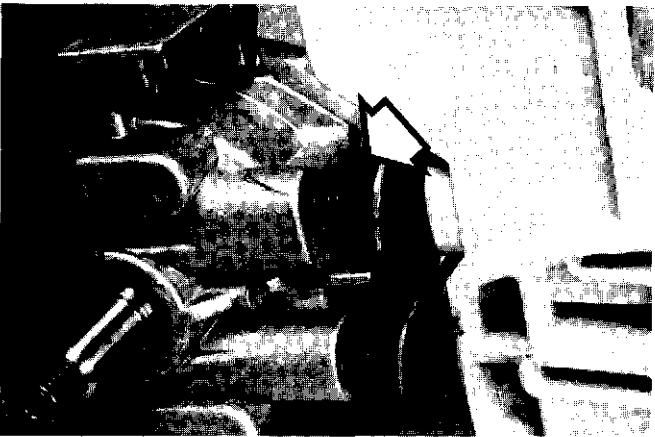

- Carefully slide the fuel/oil tank forward to check/replace the gasket that forms inlet and delivery channels for the oil pump. NOTE: A collapsed gasket will restrict oil flow.



- Slide the oil pump worm over the crankshaft and, using a suitable tube-style aluminum drift, tap the gear down to within .025" of the crankcase/seal face. Apply grease to the worm gear teeth. Continue assembly in reverse order to disassembly. NOTE: Apply loctite 242 to the pump securing screws.

NOTES

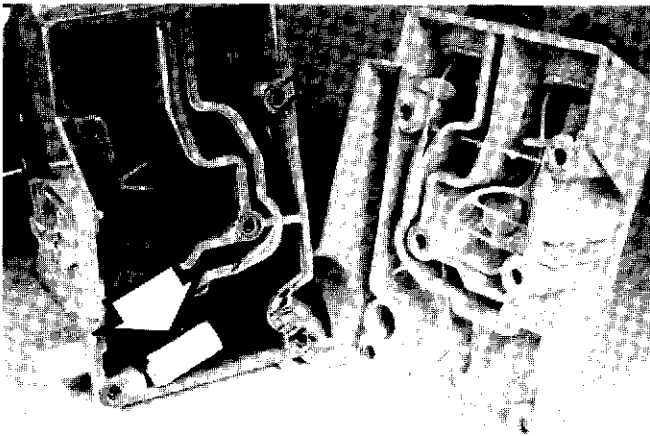
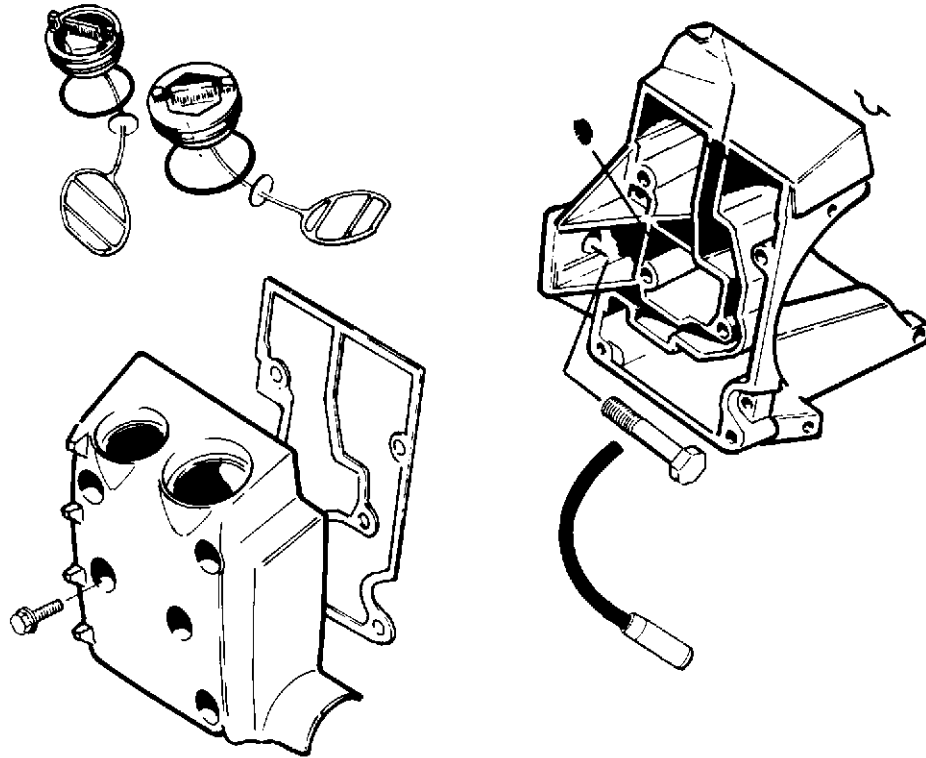

- The fuel pick-up/filter assembly is accessed by removing the fuel/oil tank cover screws. A fouled filter will restrict fuel flow and must be replaced. The end of the fuel hose should butt tightly to the filter body.

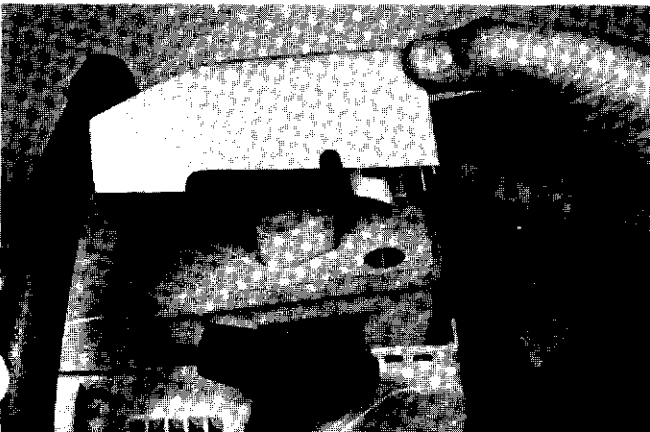

- Remove the air filter cover.

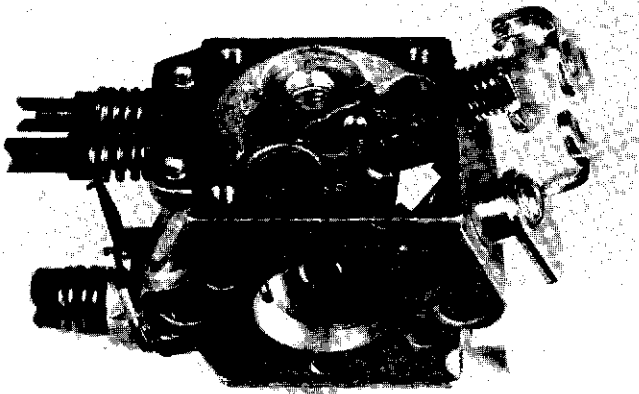

- If the carburetor is flooding (rich beyond adjustment) the inlet lever may be set too high or the needle valve/seat may be worn, dirty or damaged. Loosen the fulcrum pin clamping screw and remove the inlet lever, inlet needle, inlet spring and fulcrum pin.

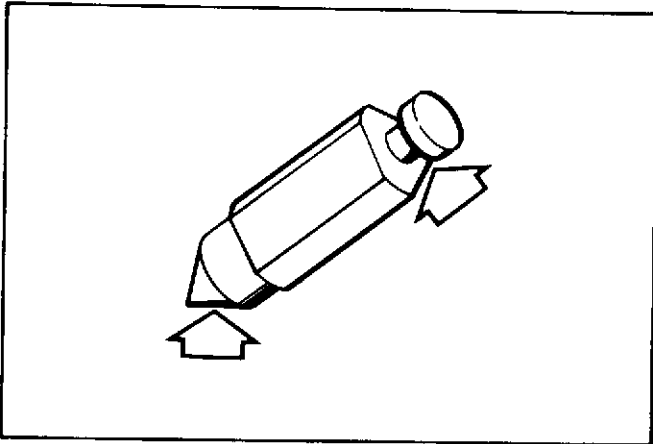

- Check the inlet needle for wear or damage. Always replace a worn or damaged needle.

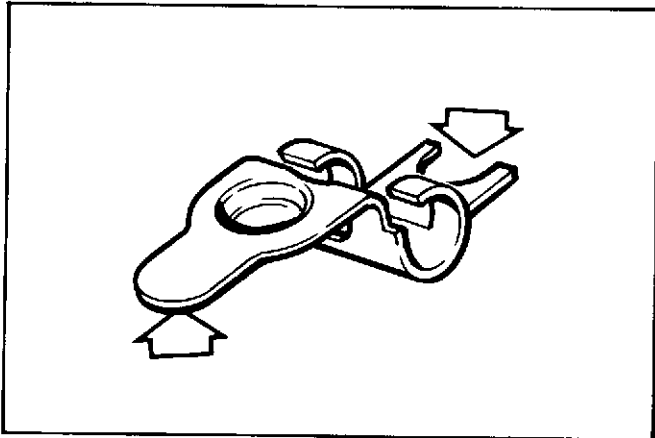

- Check for inlet lever wear at the points shown. Always replace a worn or malformed lever.

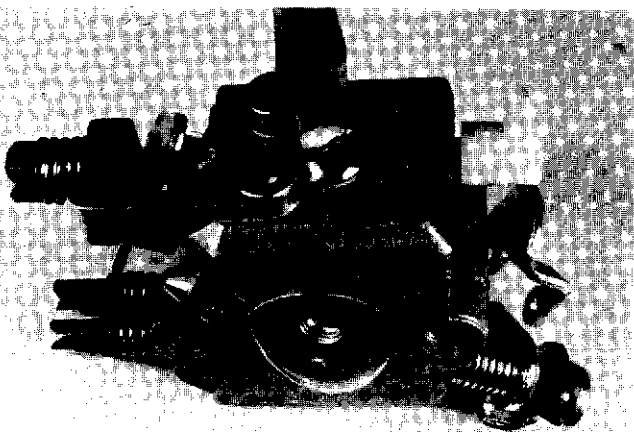

- Remove the central screw securing the pump section cover. Lift off the cover.

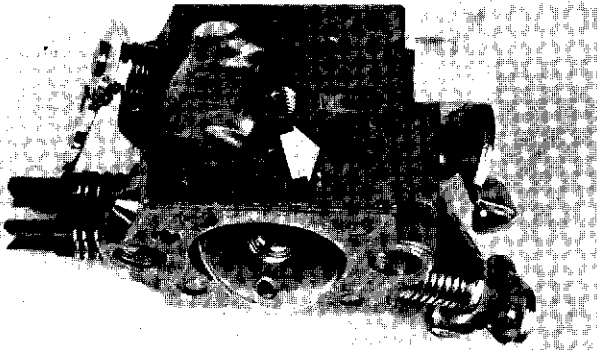

- Remove the gasket and pump diaphragm. NOTE: The gasket is positioned next to the pump cover. Using a needle, carefully remove the fuel inlet screen.

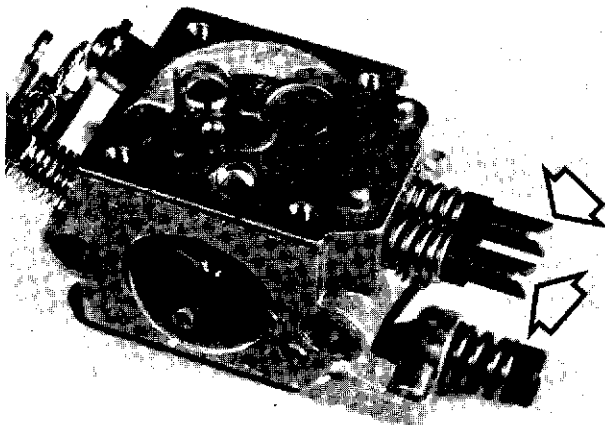

- Remove the high and low speed adjustment needles and check for damage to the needle tips. Blow the passages clear and install the needles. Gently seat the needles and open to one (1) turn open on both needles.

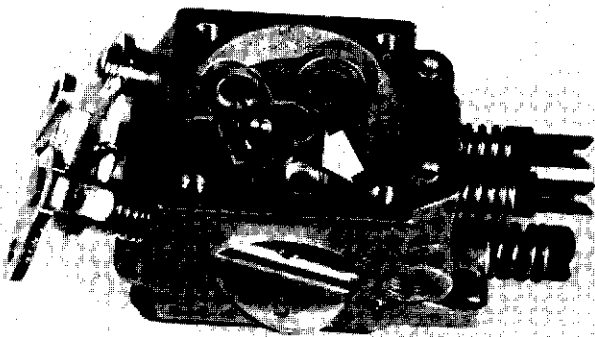

- Using a sharp pointed tool (or a small diameter drill) carefully pierce the high speed nozzle cup and pry it out. This will allow access to the nozzle screen, clip and discharge port into the venturi. Install new discharge port screen, clip and cup. NOTE: A little clear lacquer (nail polish) is an effective means of ensuring a seal after installation.

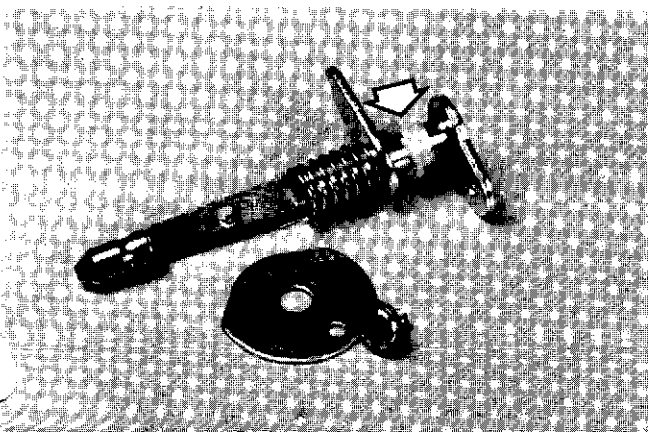

- Remove the choke and throttle valve/shaft assemblies. Check for wear or damage that would effect engine idle. NOTE: 1) Always replace the valve and shaft as a set, and carefully loctite the screws. 2) Check for any signs of wear in the nylon bushing separating the choke/throttle interlock.

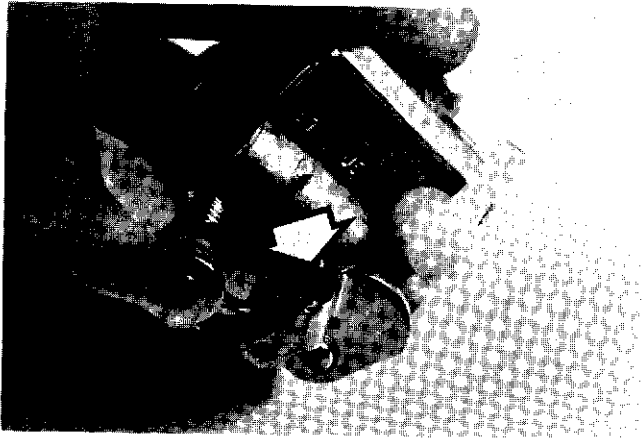

ASSEMBLY

- Install the throttle and choke valve/shaft assemblies. NOTE: Check for smooth, positive action of the spring-loaded choke/throttle inter-lock system (designed to open the throttle slightly during full choke cold starting procedures).
- Thoroughly clean and blow out all orifices. Assemble the carburetor components in the reverse order to disassembly. NOTE: Be sure the inlet lever tension spring is correctly located in the cast pocket in the carburetor body.

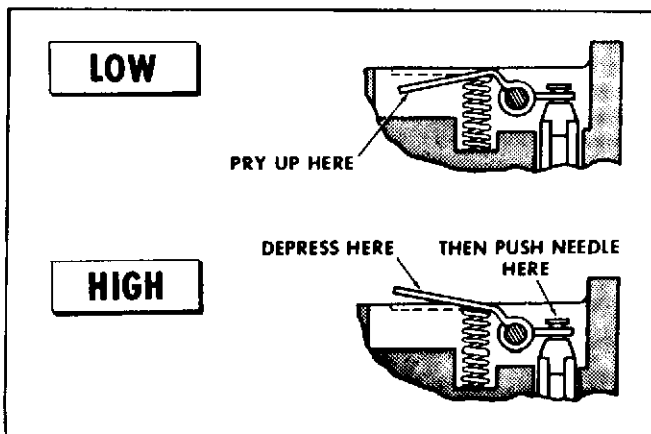
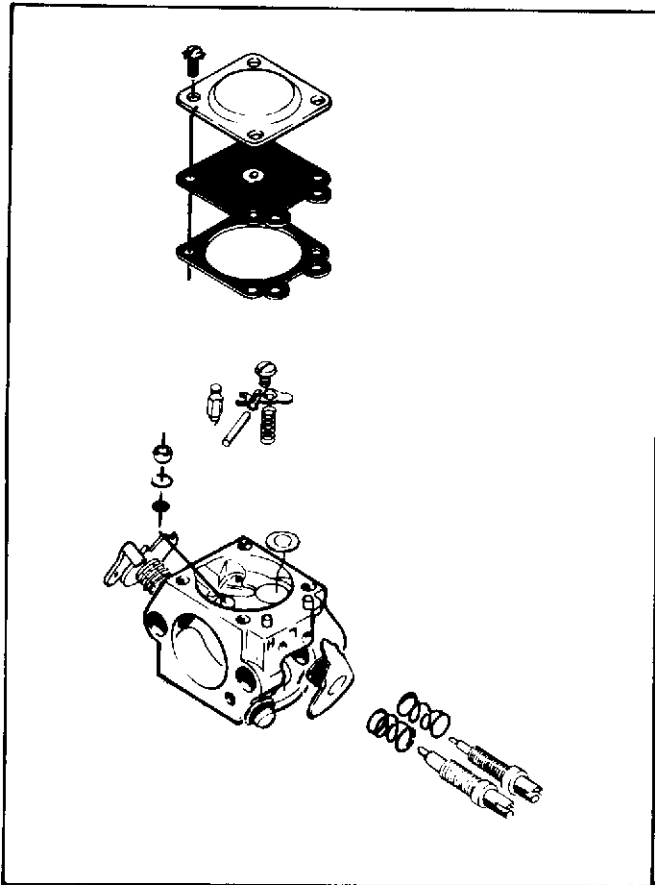

- Set the inlet lever flush (level) with the raised areas cast in the body (at the edge of the inlet lever pocket). NOTE: An inlet lever set **too low** will deliver too little fuel. An inlet lever set **too high** will deliver too much fuel.

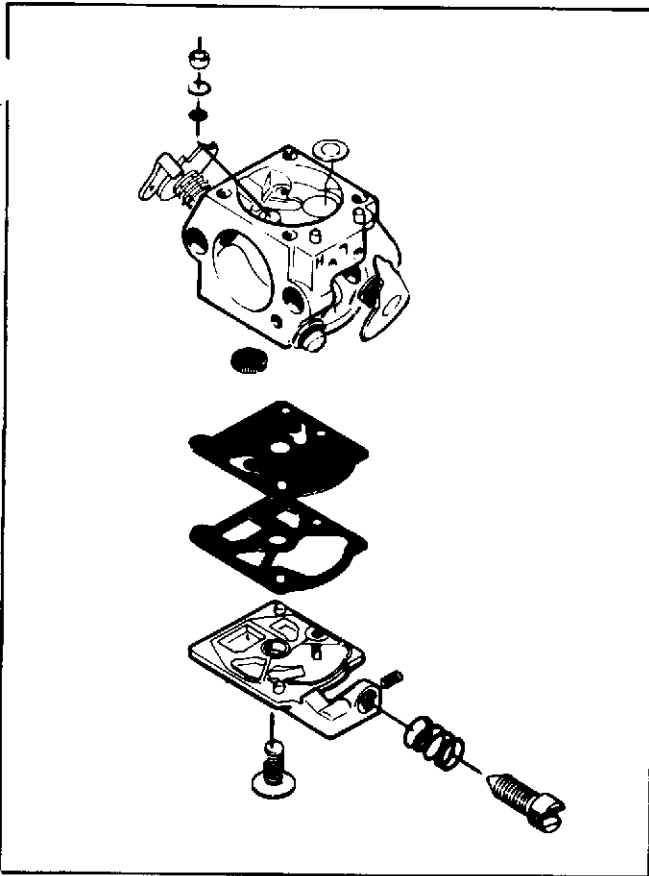

- Assemble the pump section of the carburetor in the reverse order to disassembly.

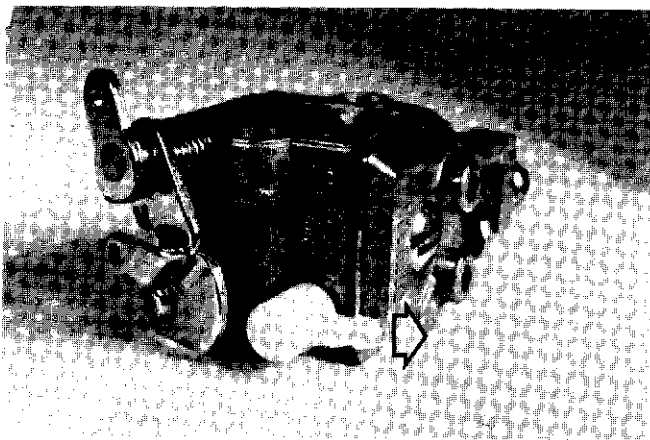

- Check that the angle of the fuel inlet nipple has not changed during servicing. The nipple should form a slight upward angle from being parallel to the carburetor mounting face.

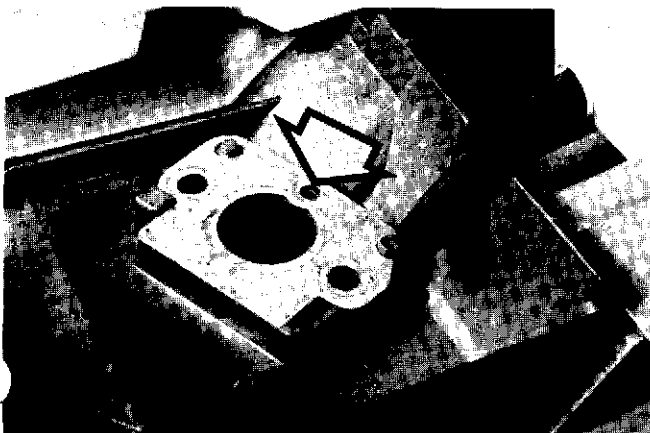

- Check that the pressure/vacuum "impulse" passage is clear in the insulating block and cylinder.

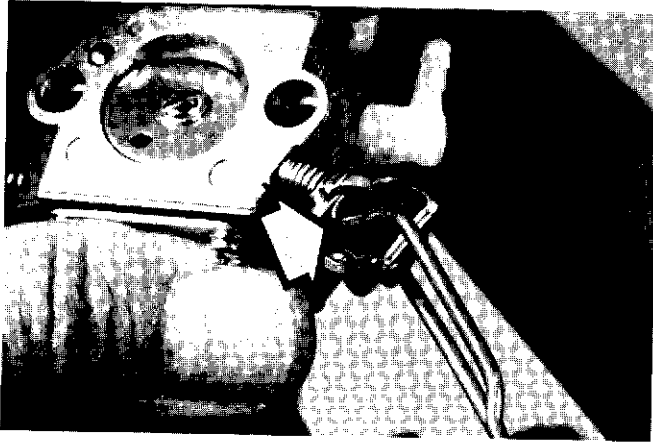

- Manipulate the carburetor to allow the dog-leg of the throttle wire and choke wire to be inserted in the throttle and choke levers.



- Push the fuel pick-up hose onto the carburetor inlet nipple.

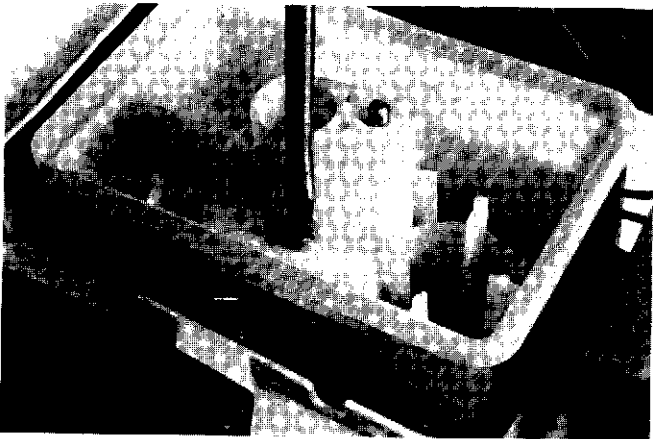

- Install the carburetor/insulating block gasket, carburetor and air filter body. Be sure to **align** all components. Insert the 2 (long) carburetor mounting screws and torque to spec. (see Section 2 Service Data).



- Install the air filter element

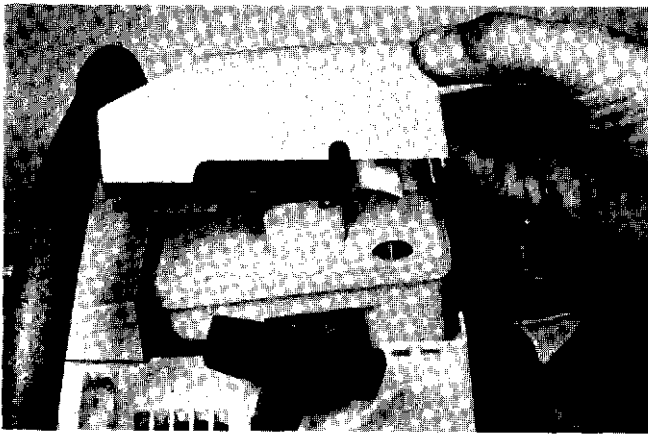

- Install the air filter cover.



CARBURETOR ADJUSTMENTS

L = Low H = High T = Idle Speed

- Gently seat the "H" and "L" needles (turn clockwise open each needle **one (1) turn** (counter-clockwise).

L - NEEDLE ADJUSTMENT

- start the saw and warm it up.
- turn the L-needle clockwise until the highest idle RPM is noted, then open the needle 1/4 turn.
- rapidly accelerate to full throttle. Too lean a setting will result in hesitation on acceleration and hard starting.

H - NEEDLE ADJUSTMENT

- start the saw and warm it up.
- rev. the engine in **short bursts** to max. RPM. **CAUTION:** Operate the engine at max. RPM only for a short period of time or the engine could be damaged.
- Open the H-needle approximately 1/4 turn until a distinct 4 stroke (rich) exhaust sound is noted.
- Check the max. speed of the saw with a tachometer. The maximum speed should **not** exceed 12,000 RPM.

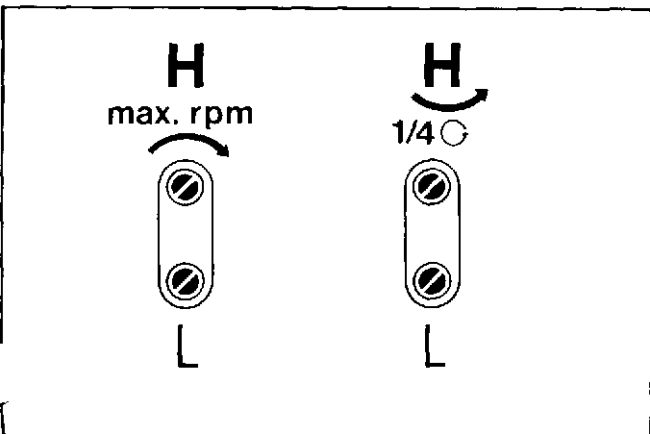
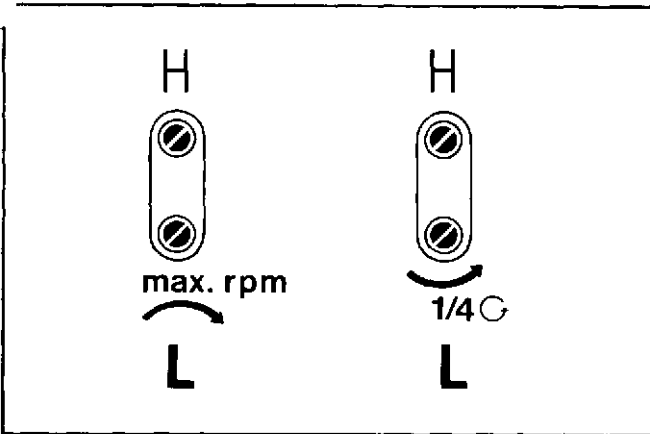
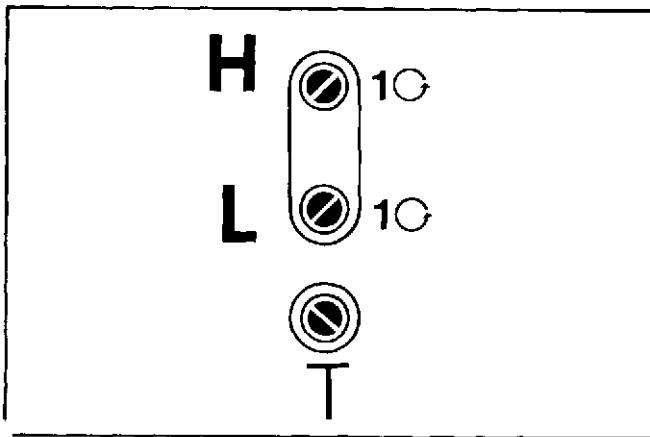

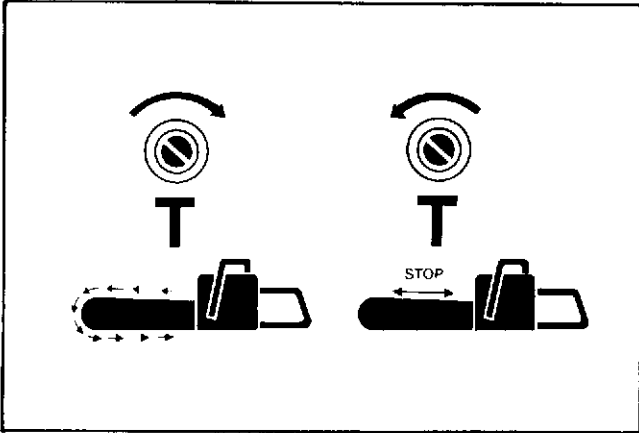

I - SCREW (IDLE) ADJUSTMENT

- adjust the T-screw clockwise until the chain starts to rotate.
- turn the screw counter-clockwise until the chain stops.
- the correct idle speed is 2500 RPM.

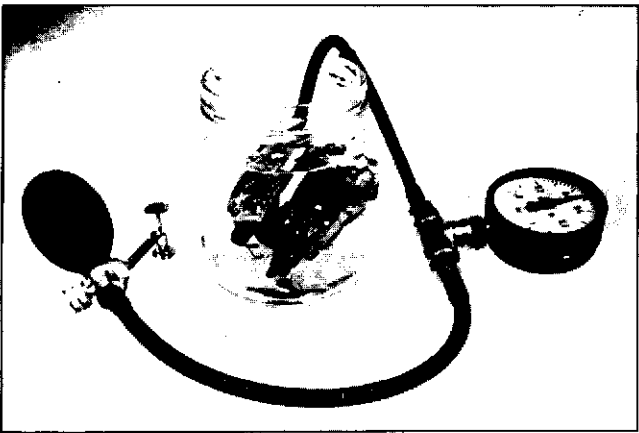

LEAKAGE TEST

Carburettor - Pressure test

Recommended pressure: 7.1 P.S.I. (No leakage permitted)

507 475467 Pressure tester

NOTES

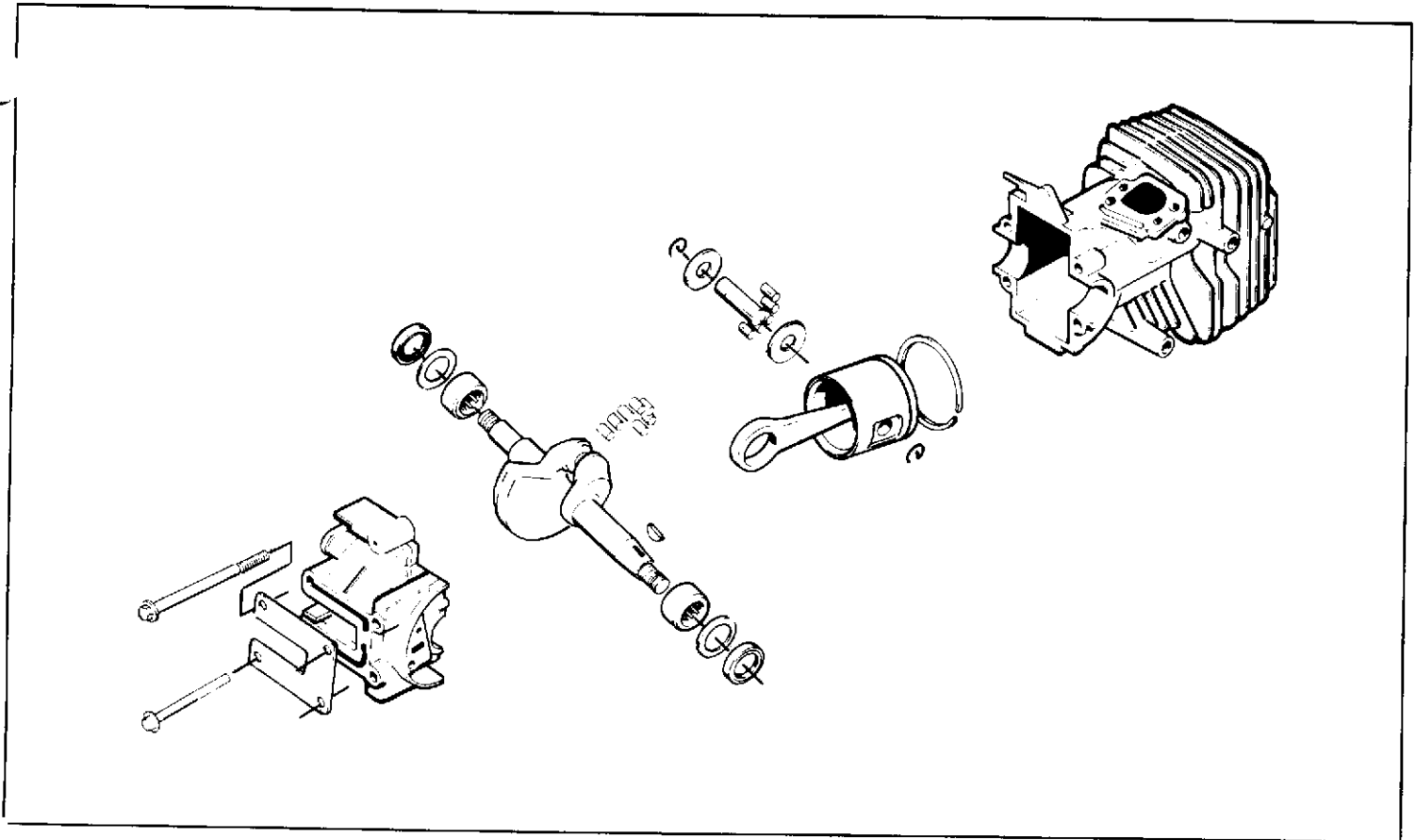

Refer to earlier manual sections and remove the starter, chain brake, clutch assembly, rear handle and frame, front handle, ignition system and oil pump.

DISASSEMBLY

NOTE: 1) The cylinder bore is chrome plated and must be replaced if scuffed or scored. 2) The crankshaft is a one-piece forging and must be replaced if damaged.

- Remove the muffler mounting bolts and the muffler cover, body and spacer tubes.

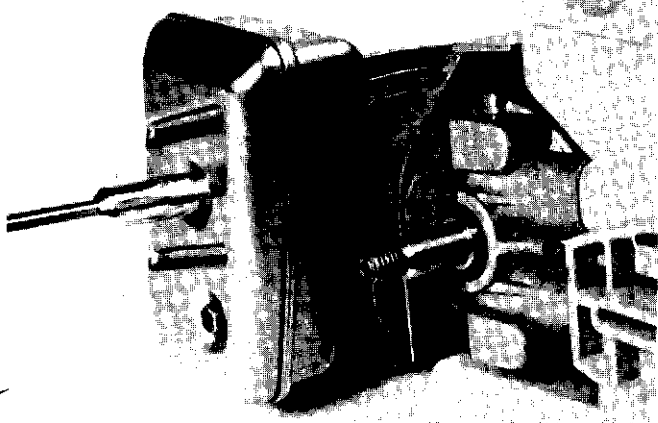

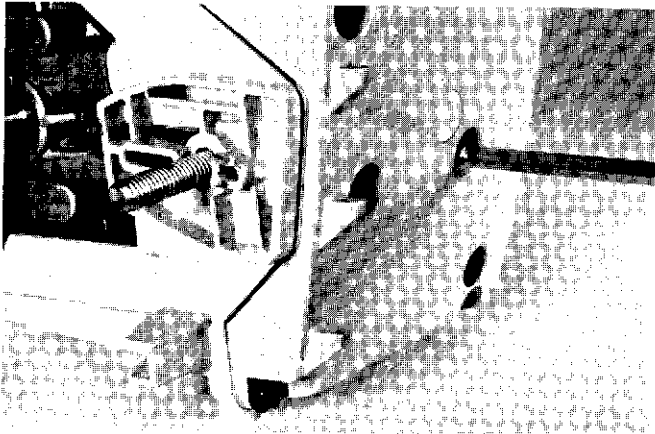

- Remove the 6 fuel/oil tank cover screws.

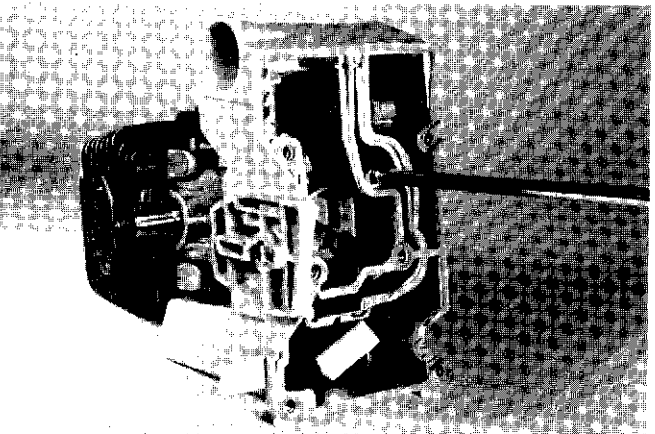

- Remove the 4 bolts securing the fuel/oil tank and crankcase end-cap to the crankcase/cylinder casting.

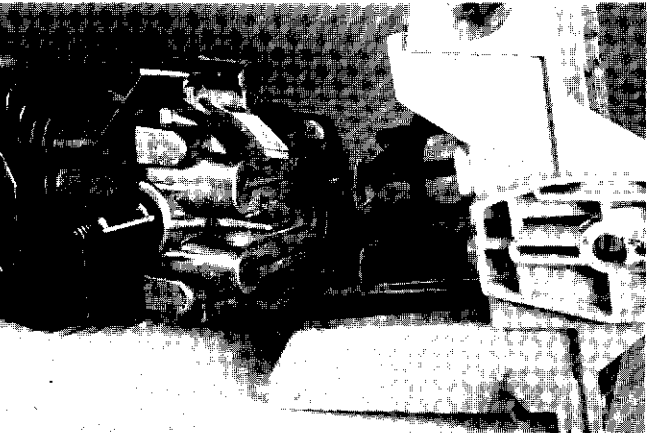

- Remove the fuel/oil tank.

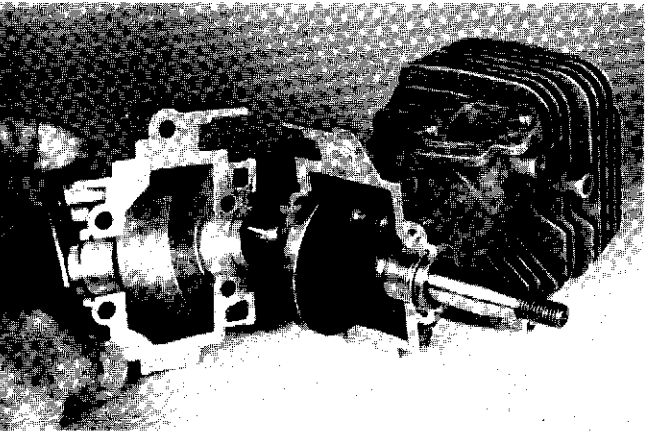

- Remove the crankcase end-cap and remove the crankshaft/conn rod/piston assembly.

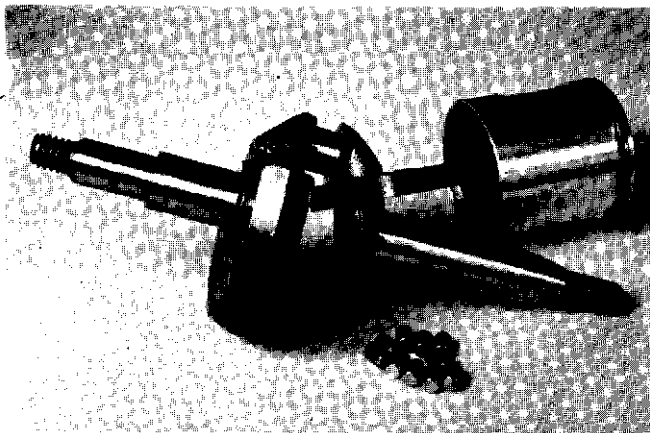

- If the conn rod/piston assembly is removed from the crankshaft, thoroughly clean all parts before reassembly.

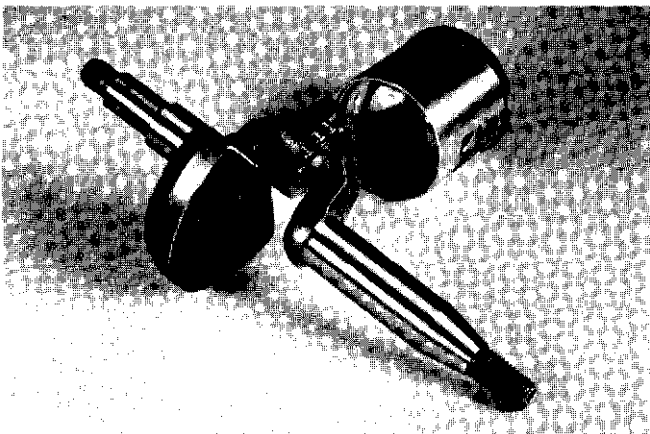

ASSEMBLY

- Stand the crankshaft vertically (clutch end down). Apply a heavy coat of grease to the crankpin (big end) journal. Place the 11 needle rollers in place around the journal and carefully thread the big end of the conn rod over the journal and needles. NOTE: The piston **must** be installed with the piston ring peg facing the flywheel end of the crankshaft. This will ensure the ends of the ring do not "clip" a port opening in the cylinder.

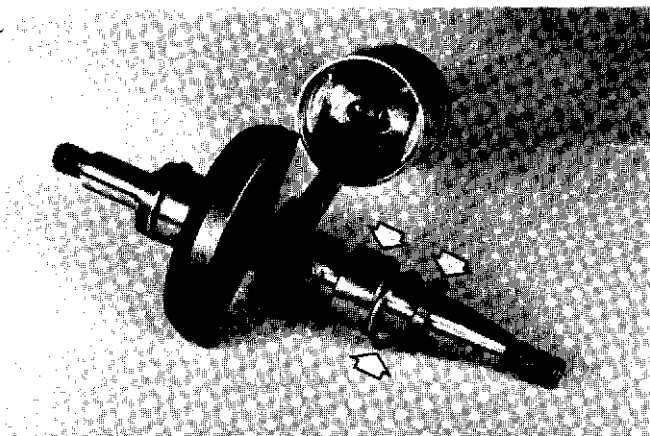

- Slide the needle-type main bearings onto the crankshaft. NOTE: The lettered ends of the bearing should face the crankshaft counterweight. Place the clip rings on the crankshaft. Oil the engine seals and **carefully** slide them over the ends of the crankshaft . . . watch that the ignition side seal lip is not cut by the sharp edges of the crankshaft keyway.

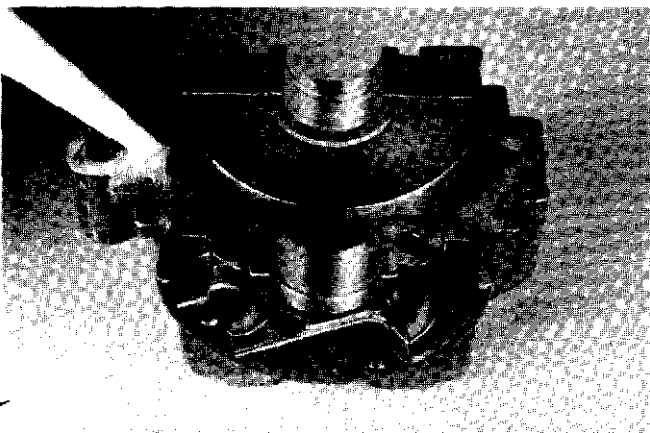

- Thoroughly clean and dry the surfaces of the crankcase/cylinder casting and the crankcase end-cap. Apply a thin, even bead of RTV sealant (or gasket eliminator) to the sealing surfaces. Do not allow excess sealant to block passages.

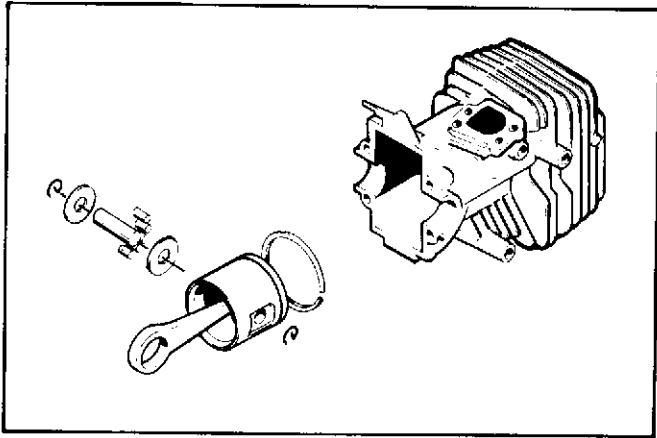

- Oil the piston ring and ring groove. Insert the piston/conn rod assembly into the cylinder bore
NOTE: Be sure the piston ring gap/peg is facing the flywheel side of the engine.

Position the main bearings, clip rings and seals. Carefully fit the crankcase end-cap. NOTE: Be sure that the clip rings are correctly nested in the machined grooves in the castings.

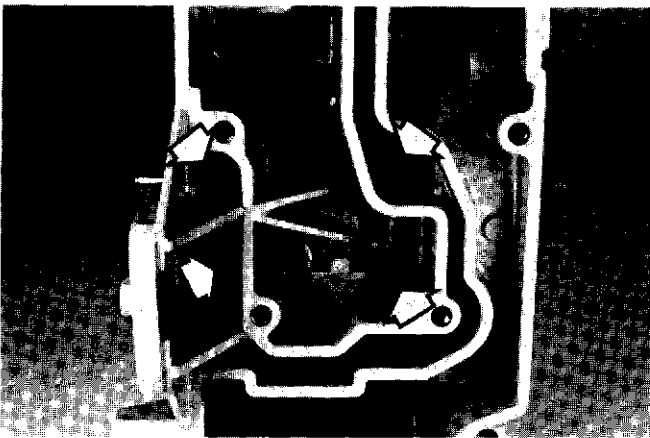

- Install a new crankcase/fuel tank gasket to ensure restriction-free oil inlet and delivery. Install the 4 crankcase/fuel tank securing bolts and torque to spec. (see Section 2 Service Data) torque the bolts down evenly in an "X" pattern.

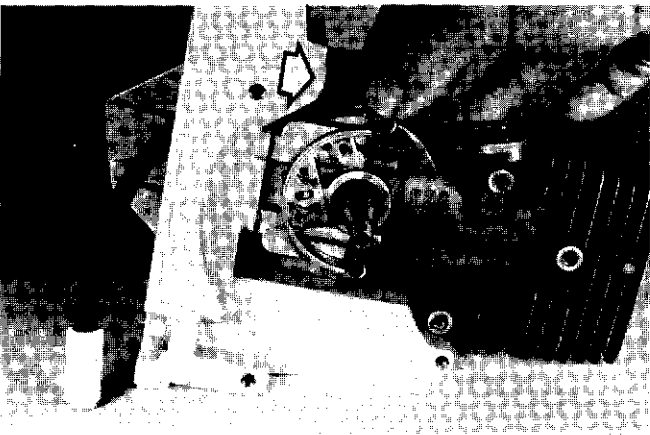

- Thread the end of the fuel pick-up hose through the tank casting and pull the hose to the point where the fuel pick-up head is sweeping the tank floor (without kinking the fuel hose).

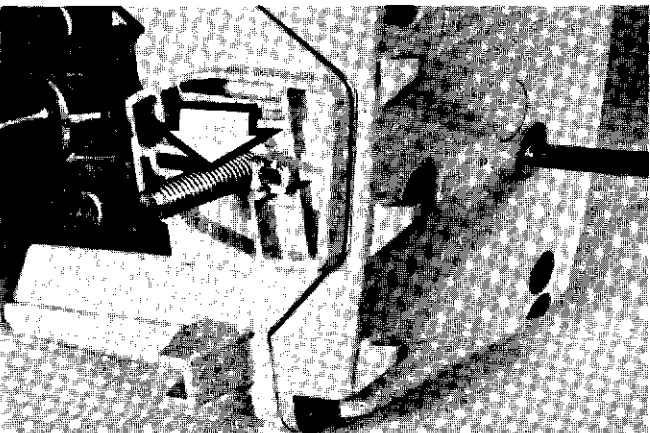

- Install the guide bar mounting bolt, fuel tank cover gasket and fuel tank cover. Install the cover securing screws and torque to spec. (see Section 2 Service Data) .

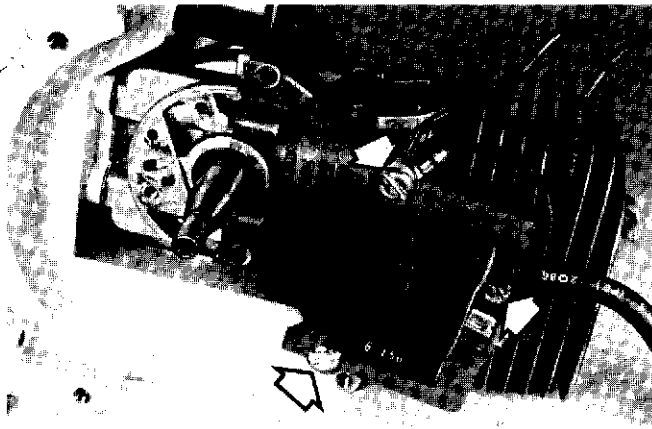

- Install the ignition module/laminate assembly. NOTE: Do **not** tighten the 3 mounting screws at this time.

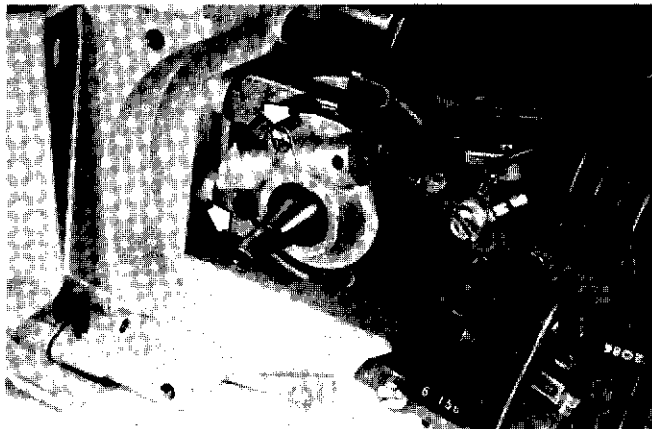

- Slide the (symmetrical) oil pump worm gear onto the crankshaft and, using a tube-type aluminum driver, tap the gear down to within .025" of the crank case/seal face. Apply grease to the worm and pinion gears. Install a new oil pump gasket and fit the oil pump assembly into place. Place the long (upper) screw and short (lower) screw in position and torque to spec. (see Section 2 Service Data).

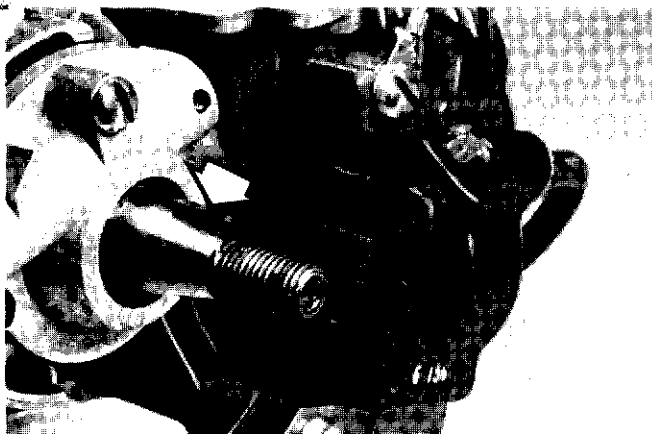

- Insert the flywheel key and press to depth. NOTE: The top of the key should be parallel to the center axis of the crankshaft and **not** the taper.

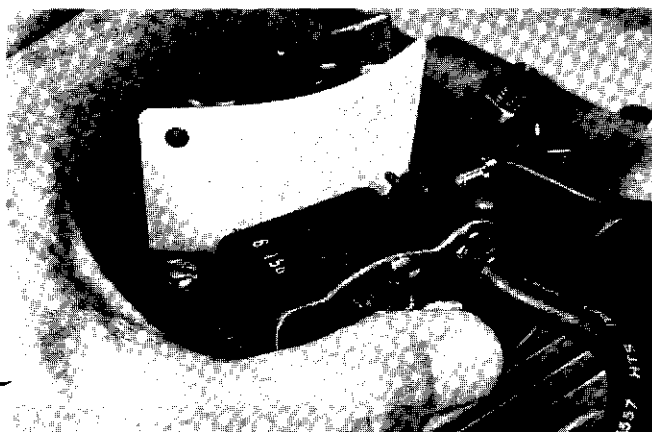

- Carefully position the flywheel keyway over the key and torque the flywheel nut to spec. (see Section 2 Service Data). Using the plastic air gap setting tool as a spacer, push the ignition module against the flywheel and torque the 3 mounting screws to spec. (see Section 2 Service Data).

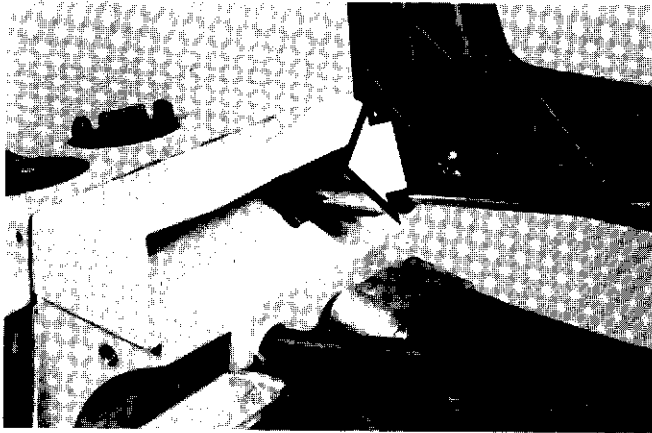

- Position and secure the rear handle/frame assembly. NOTE: Be sure to install the shock mount safety restraint strap.

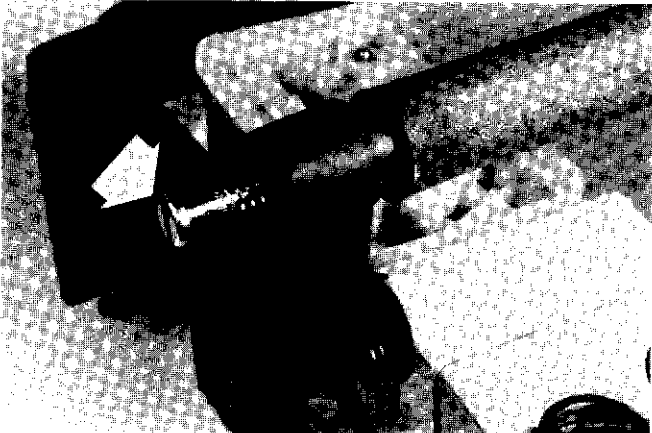

- Fit the front handle and lower shock mount. The upper fastener (shown) has a special "thread form" that will offer resistance during both the removal and assembly procedures.

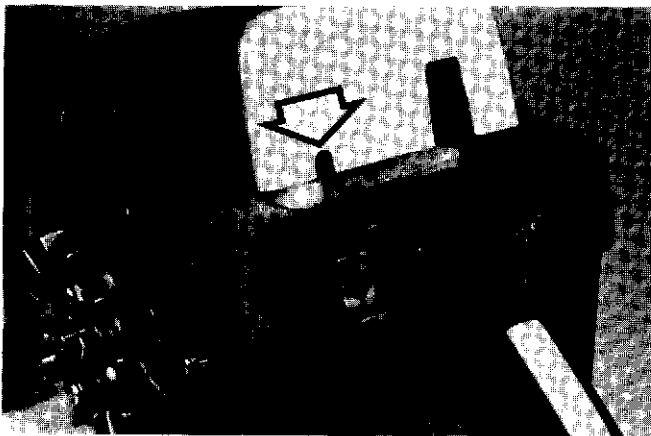

- Assemble the air filter element and the air filter cover. NOTE: The on/off switch wiring nests in the notch provided in the lower rear edge of the top cover.

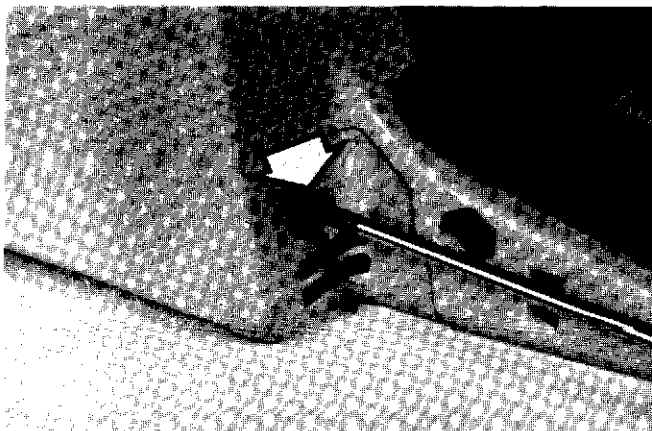

- Install the spark plug. Position and secure the starter assembly. Assemble the spark plug access cover to the starter housing (shown).

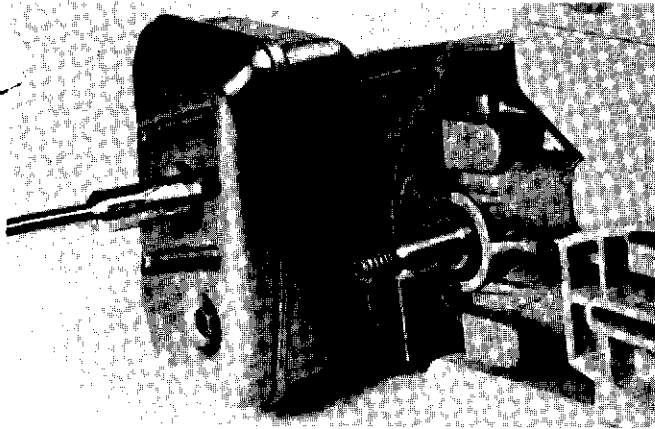

- Assemble the muffer gasket (new), muffer body, spacer tubes and muffer cover to the cylinder. Torque the muffer bolts to spec. (see Section 2 Service Data).

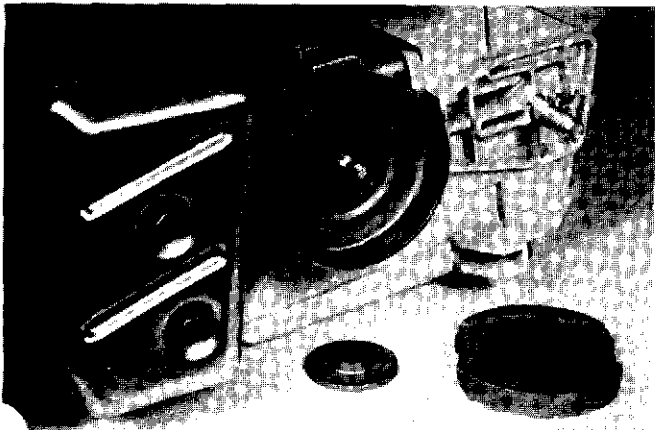

- Install the clutch drum and clutch assembly as discussed in an earlier section. Fit the guide bar, chain and clutch cover to complete the assembly.

NOTES

11 TROUBLE-SHOOTING CHART

START

	1	2	3	4	5	6	7	8	9	10	11	12	13	14	15	16	17	18	19	20	21	22	23	24	25	
A	•			•	•							•											•	•	•	
B							•			•																
C																										

IDLE

D	•		•	•	•	•	•					•	•					•	•	•	•					
E	•																									
F																										
G						•	•					•	•	•		•										•
H						•																				
J																										

ACCELERATION, DECELERATION

K	•	•	•	•	•	•	•		•	•	•	•	•													
L	•	•										•														
M	•	•										•	•													

HIGH SPEED

N		•	•	•	•	•	•	•	•	•	•	•														
O		•	•	•				•	•	•	•	•														
P			•	•	•	•	•	•	•	•	•	•														

START

- A. Hard starting
- B. Fuel dripping from carburetor
- C. Floods engine when not running

IDLE (Low speed)

- D. Will not idle
- E. Rich idle
- F. Idles with needle closed
- G. Erratic idle
- H. "L" needle needs frequent adjustment
- J. Loads up while idling

ACCELERATION, DECELERATION

- K. Will not accelerate
- L. Engine stops when closing throttle
- M. Over-rich acceleration

HIGH SPEED

- N. Will not run at full throttle
- O. Low power
- P. Will not 4 cycle (no rich drop off)

26	27	28	29	30	31	32	33	34	35	36	37	38	39	40	41	42	43
	•					•			•		•	•	•	•	•		
	•												•	•	•		

																		•
•	•		•										•	•	•	•	•	
	•		•										•	•	•	•	•	
			•			•	•				•	•	•	•			•	
	•		•			•				•				•		•	•	
	•		•	•	•								•	•	•	•	•	

		•						•							•			•
	•														•			•
																		•

		•	•	•	•							•	•	•				
			•			•		•	•	•	•	•					•	
		•				•		•	•	•	•	•						

ADJUSTMENTS

1. Low speed needle
2. High speed needle

FUEL SYSTEM

3. Plugged tank vent
4. Plugged tank filter
5. Restricted fuel line
6. Dirt in fuel passage
7. Loose, damaged fuel line
8. Leak in pulse system
9. Restricted pulse channel
10. Loose pump cover screws
11. Defective pump diaphragm

AIR SYSTEM

12. Plugged air filter
13. Defective manifold gasket
14. Loose carb. mounting bolts
15. Worn throttle assembly
16. Incorrect throttle assembly
17. Loose throttle valve screw
18. Throttle shaft too tight
19. Bent throttle linkage
20. Defective throttle spring
21. Bent throttle stop lever
22. Choke not functioning properly
23. Worn choke shaft
24. Worn choke valve
25. Worn throttle valve

METERING SYSTEM

26. Worn lever
27. Set too high
28. Set too low
29. Not free
30. Distorted
31. Improperly installed
32. Leaking (air/fuel)
33. Worn button
34. Improper assembly
35. Defective gasket
36. Loose diaphragm rivet
37. Hole in diaphragm
38. Loose cover screws
39. Foreign matter
40. Binding
41. Worn needle body or tip

CIRCUIT PLATE

42. Loose screws, bad gasket
43. Nozzle check valve

