

For Husqvarna Parts Call 606-678-9623 or 606-561-4983

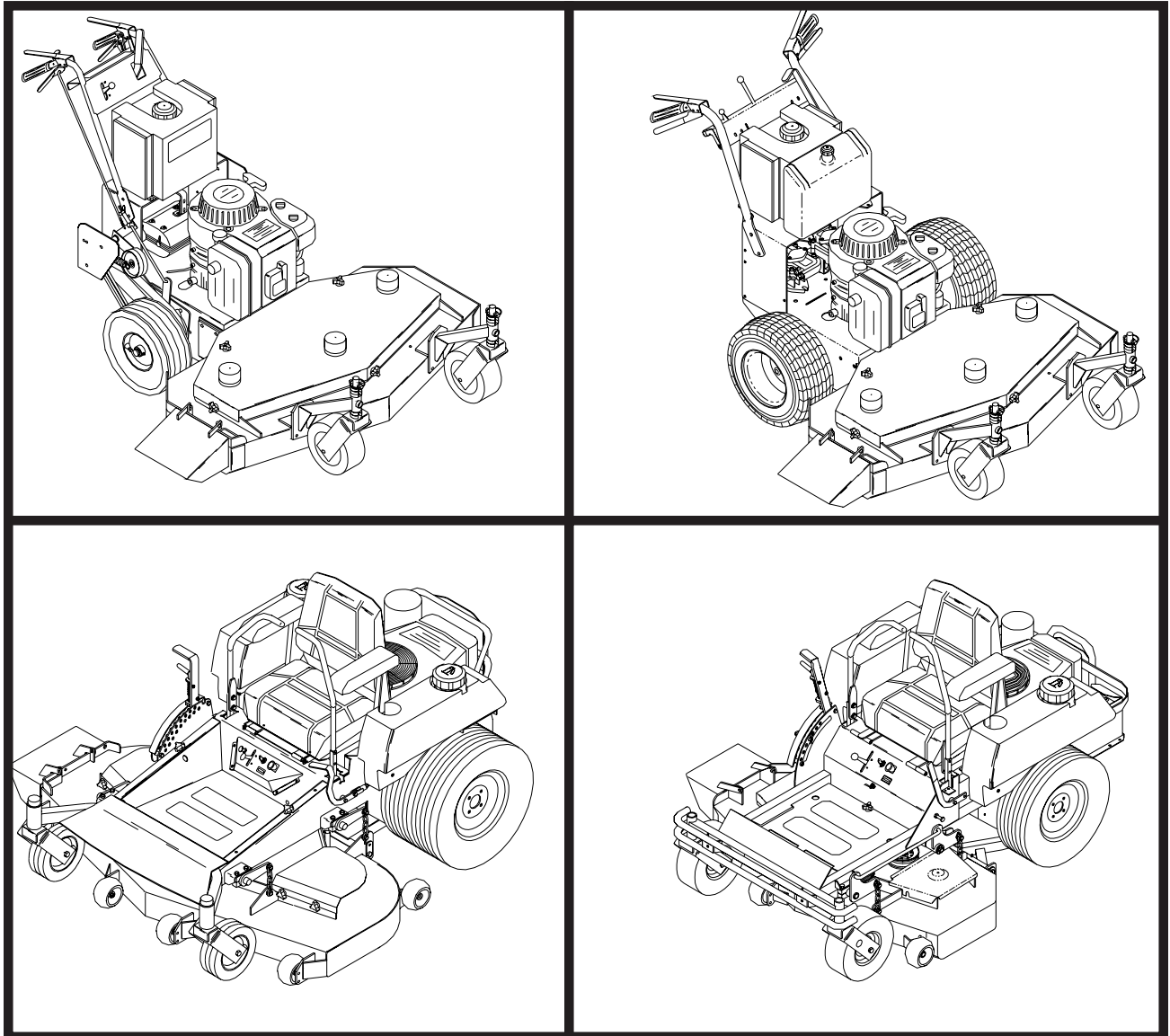

## Adjustments manual for:

Gear Drive, ETS Gear Drive, Walk Hydro, ETS Walk Hydro, Mini Rider, Large Rider Gen 2

MANUAL NO. 539105471 REV. 01(03/14/02)

[www.mymowerparts.com](http://www.mymowerparts.com)

## Gear Drive Intermediate Walk Behind

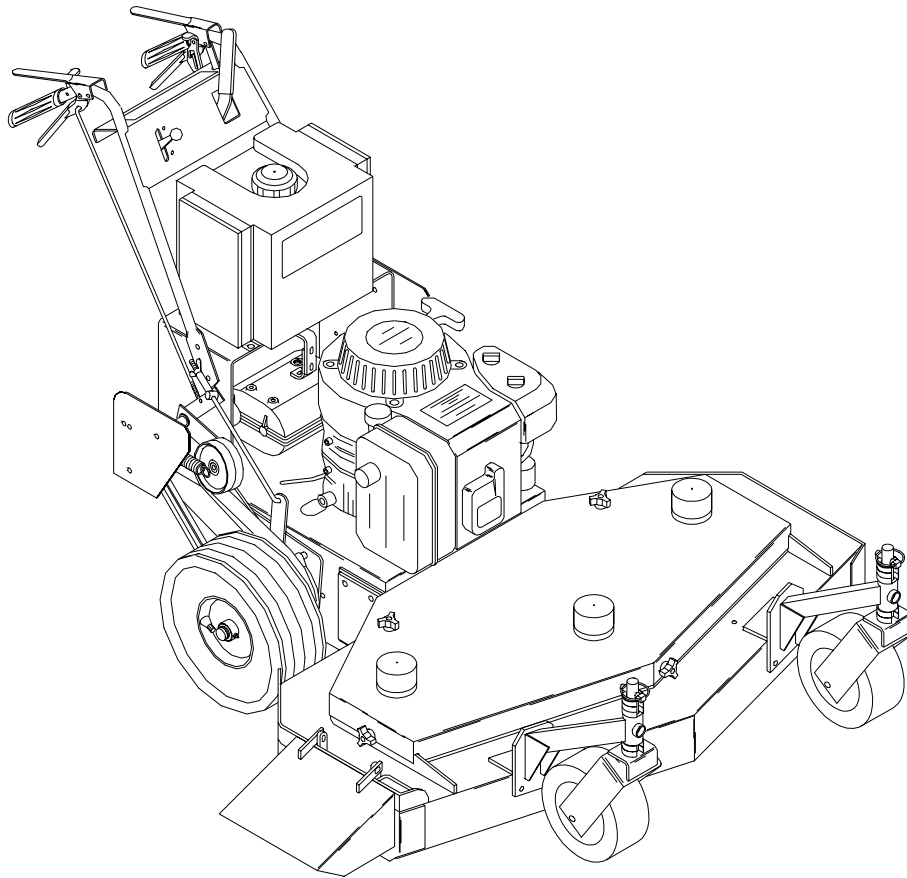

### Adjustment Instructions for:

MODELS / I.D. : 968999101 / W3212A  
968999107 / W3213A  
968999102 / W3612A  
968999108 / W3613A  
968999103 / W3614A  
968999104 / W4814A  
968999110 / W4815A

## ADJUSTMENTS FOR HUSQVARNA 32", 36" AND 48" COMMERCIAL MOWERS

### AXLE HEIGHT ADJUSTMENT

1. To adjust rear axle, stop engine and place drive levers in the neutral lock position, remove spark plug wire.
2. Remove lower belt shield from underside of rear deck for better access to axle adjustment bolts.
3. Loosen axle pivot bolts and axle adjustment bolts. See figure # 1.
4. Place a jack under center of rear deck raise the jack slightly so axle adjustment bolts may be removed.
5. With the jack raise or lower the rear deck to the desired position using the chart to ensure proper height. Reinstall the axle adjustment bolts and tighten. A tapered punch may be used to help align the holes. See figure #1.

#### NOTE:

It may be necessary to readjust drive and brake linkages.

#### NOTE:

To achieve the best quality cut, the blades should be level with the ground or slightly tipped forward

### BRAKE/TRACTION ADJUSTMENT

1. Disconnect the brake linkage from the brake band arm.
2. With the mower in gear, place the traction levers in the drive position. Firmly pull back on the handles until the tires slide to seat the wheel drive belts into the pulleys.
3. Measure the clearance between the bottom of the traction lever rod and the bottom of the thumb latch slot. It should be between 3/16" to 1/4", but not exceeding 1/4". See Figure # 3

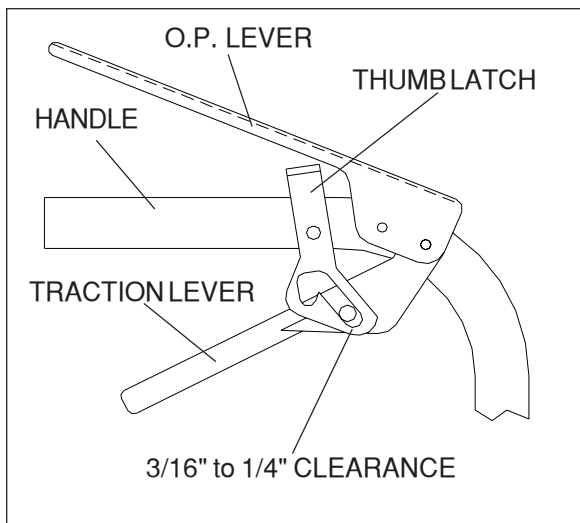

Figure 3

4. If the clearance is less than 3/16", disconnect the traction rod from the traction lever by removing the hairpin cotter.
5. Adjust the traction rod to the proper clearance by screwing it out of the swivel if clearance is less than 3/16".

#### NOTE:

More or less brake pressure may be desired depending on the operator or conditions of operation. To increase pressure tighten the wing nut on the brake linkage.

### OPERATOR PRESENCE SWITCH ADJUSTMENT

The operator presence switches can be adjusted by loosening the screws on the side of the O.P. lever linkage and sliding the switch up or down. The O.P. switch should have a 1/32" to 1/16" gap between the plunger and the bottom side of the control panel when operator presence levers are released.

### BLADE SWITCH ADJUSTMENT

The blade engagement switch can be adjusted by loosening the screws on the flange under the control panel and moving the switch in or out. The blade switch should be adjusted so the plunger is fully depressed when the engagement lever is fully disengaged.

### ADJUSTMENTS-DRIVE BELTS

For all drive belts, tension should be set so that belt vibration is minimized or eliminated when belts are moving during normal operation. A properly tensioned belt should have 1/4" to 3/8" deflection at the center of belt span between pulleys when blades are engaged. Blade drive belt tension is preset at the factory.

#### NOTE:

DO NOT over tighten belt. Excessive tension will decrease belt and spindle bearing life.

**REAR AXLE HEIGHT ADJUSTMENT**

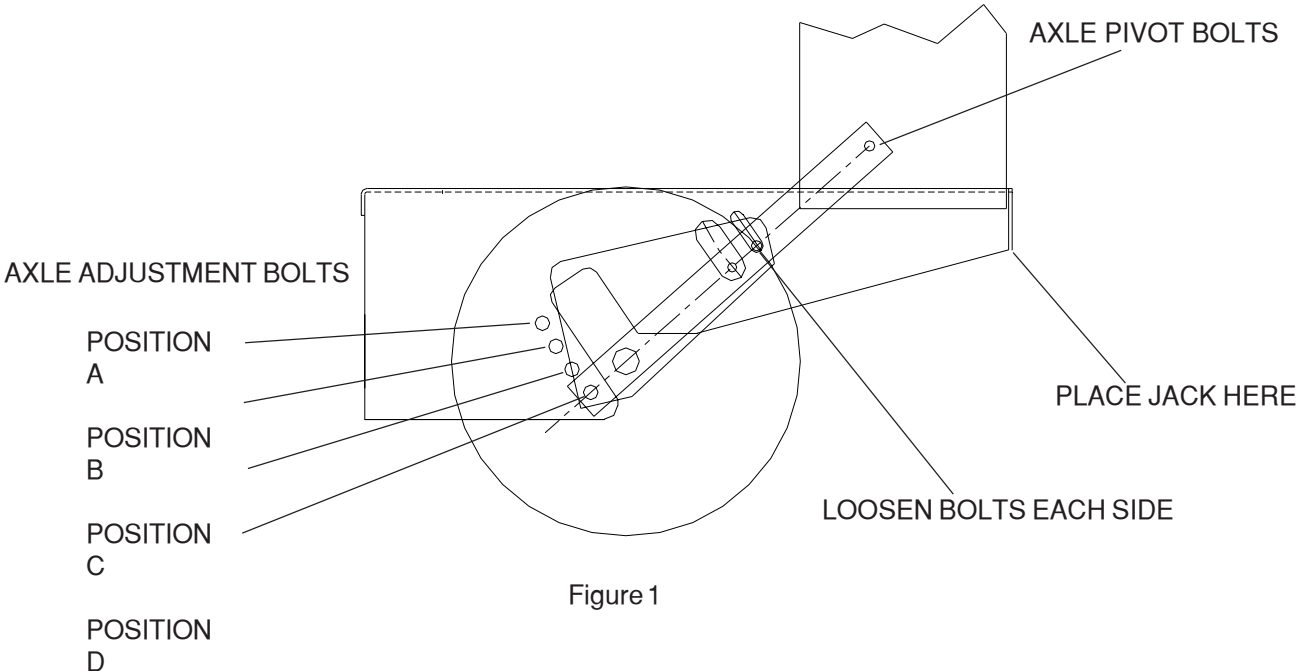

**CASTER HEIGHT ADJUSTMENT**

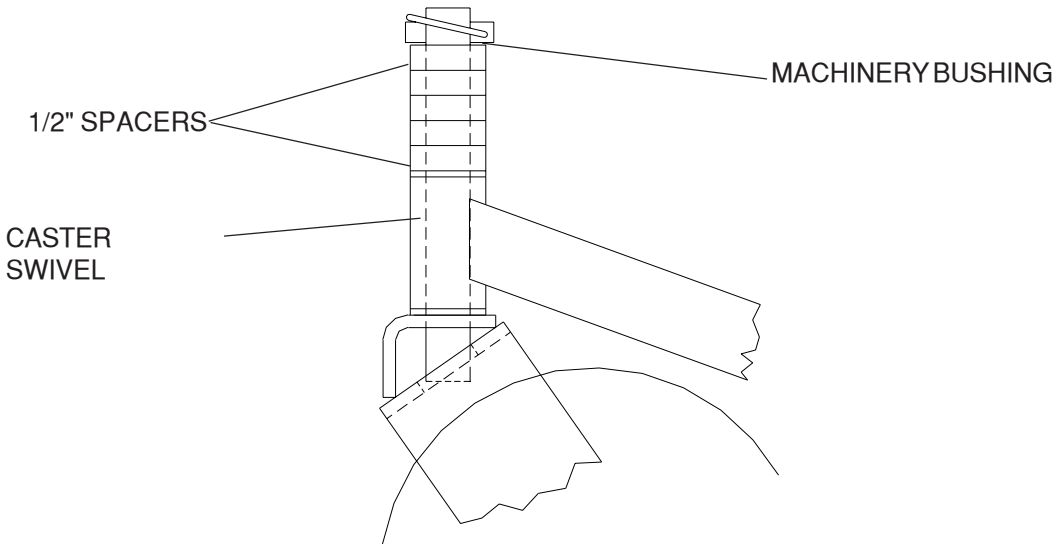

## BLADE DRIVE BELT ADJUSTMENTS

**WARNING**  
**BEFORE PERFORMING ADJUSTMENTS ON**  
**BLADE BELT, TURN MOWER OFF, CLOSE FUEL**  
**VALVE, AND DISCONNECT SPARK PLUG WIRE.**

1. Remove front deck belt shield.
2. Loosen whiz nut on turnbuckle.
3. Set belt tension when engagement lever is in the engaged position.
4. To increase belt tension rotate turnbuckle toward the rear of the mower until desired tension is gained. Do not over tighten belts, to much tension will reduce belt and spindle bearing life. See figure # 6
5. Tighten whiz nut on turnbuckle and install belt shield.

### AUXILIARY BLADE DRIVE BELT (48" MODELS ONLY)

To adjust tension of the auxiliary belt rotate nut on linkage that is attached to deck strap located on the right side of cutter deck.

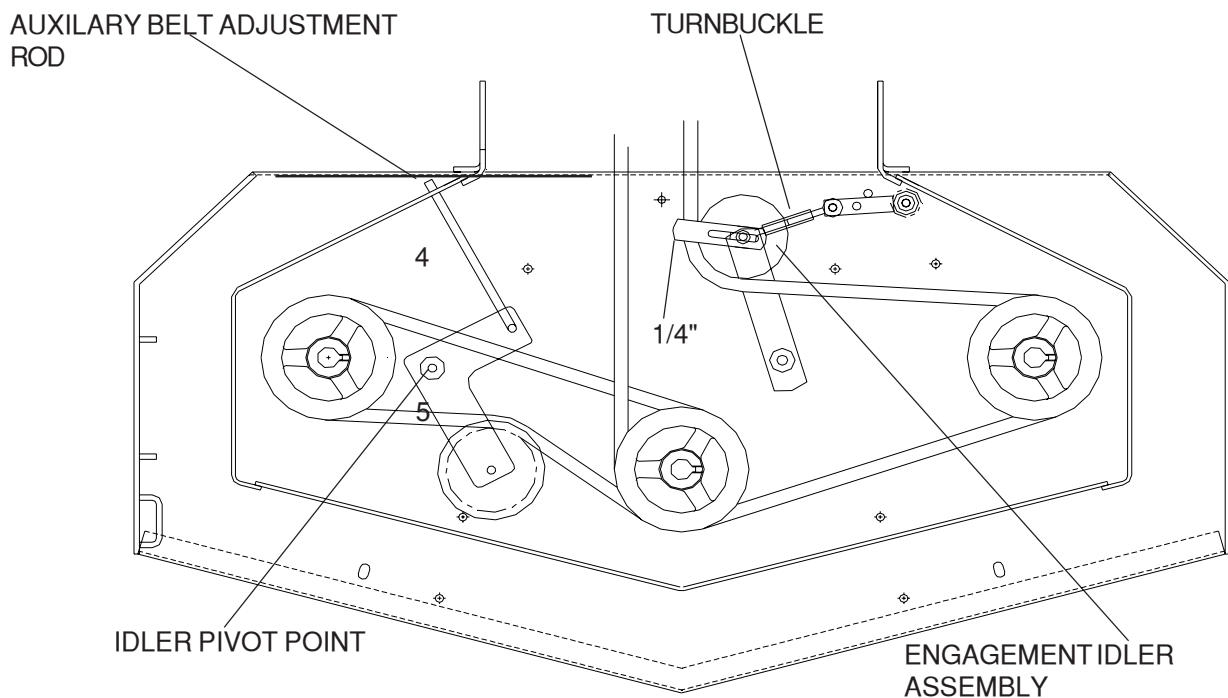

Figure 6

## SETUP AND ADJUSTMENTS FOR HUSQVARNA 32", 36" AND 48" COMMERCIAL MOWERS

### TRANSMISSION DRIVE BELT

To increase the tension of the transmission belt, loosen the nut on the underside of the transmission idler pulley located under the rear deck, slide the idler assembly inward to increase tension and tighten the nut to secure. See figures 4 & 5.

### BELT GUIDES

Belt guides under rear deck are adjusted as shown in figures 4 and 5

**NOTE: The blades should come to a stop from maximum speed within 7 seconds after disengaging.**

### BLADE ENGAGEMENT LEVER

The blade engagement lever needs to be adjusted so the lever does not come in contact with control panel when the lever is in the off position.

To adjust, remove the clevis pin from the yoke and adjust by turning the yoke. The clevis pin connects the blade engagement lever to the yoke, and the yoke is connected to the blade engagement rod that runs to the bellcrank on the rear deck.

**32" & 36" MODEL**

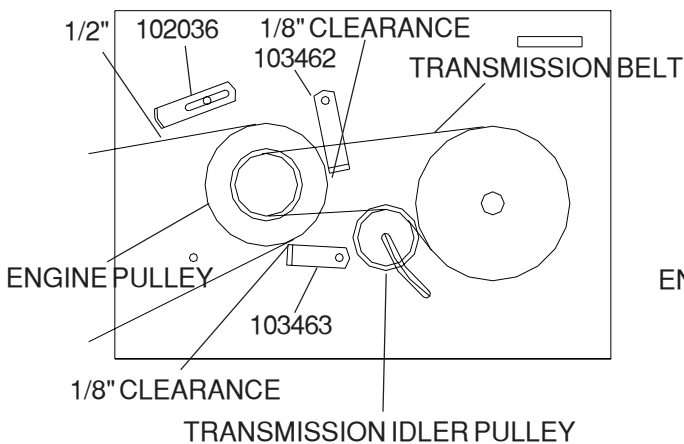

Figure 4

**48" MODEL**

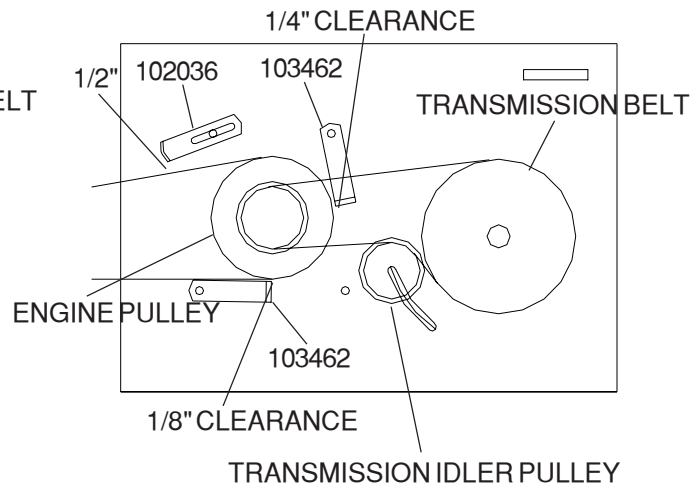

Figure 5

## SETUP AND ADJUSTMENTS FOR HUSQVARNA 32", 36" AND 48" COMMERCIAL MOWERS

### CUTTING HEIGHT ADJUSTMENT CHART

AXLE POSITION	NUMBER OF SPACERS BELOW CASTER ARM	NUMBER OF 1/4" BLADE SPACERS UNDER CUTTER HOUSING	CUTTING HEIGHT (IN INCHES)
A	0	4	1 1/2
		3	1 3/4
		2	2
		1	2 1/4
		0	2 1/2
	1	4	1 3/4
		3	2
		2	2 1/4
		1	2 1/2
		0	2 3/4
B	2	4	2 1/2
		3	2 3/4
		2	3
		1	3 1/4
		0	3 1/2
	3	4	3
		3	3 1/4
		2	3 1/2
		1	3 3/4
		0	4
C	3	4	3 1/4
		3	3 1/2
		2	3 3/4
		1	4
		0	4 1/4
	4	4	3 1/2
		3	3 3/4
		2	4
		1	4 1/4
		0	4 1/2
D	4	4	3 3/4
		3	4
		2	4 1/4
		1	4 1/2
		0	4 3/4
	5	4	4
		3	4 1/4
		2	4 1/2
		1	4 3/4
		0	5

1. To quickly achieve small changes in cutting heights, move the spacers from under the cutter housing to above the cutter pulley. (Each spacer moved will give an additional 1/4" of cutting height ).

**USE ONLY 4 BLADE SPACERS MAXIMUM**

For Husqvarna Parts Call 606-678-9623 or 606-561-4983

## ETS Gear Drive Intermediate Walk Behind

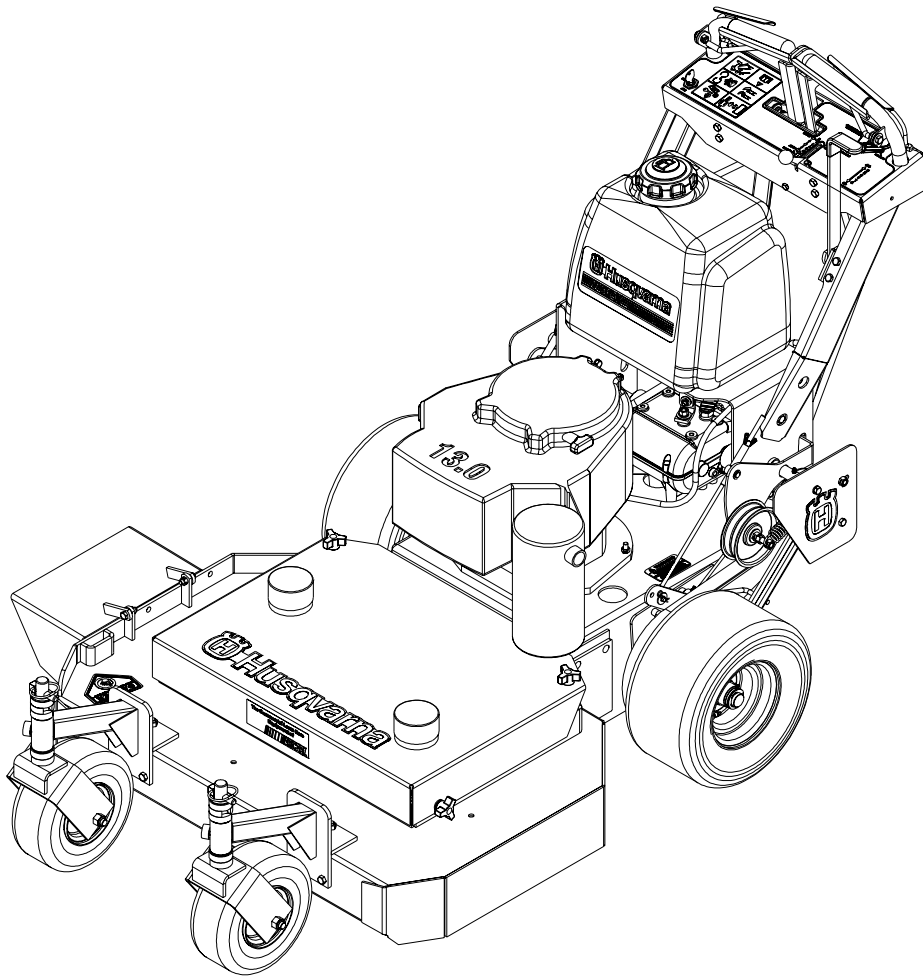

### Models:

968999117 / W3613ETS  
968999120 / W4815ETS



## Setup & Adjustments

### MAINTENANCE

1. Keep all nuts, bolts, and screws tight to keep mower in safe operating condition.
2. Never store the mower with gas in the tank inside a building where fumes can reach an open flame or spark. Allow engine to cool before storing in an enclosure.
3. To reduce fire hazard, keep mower free of grass, leaves, or excessive grease.
4. Check grass catcher assembly frequently for wear or deterioration. Replace bag if loose seams or tears are evident.
5. Have your mower inspected and serviced each year by an authorized **HUSQVARNA** dealer. Determine if any additional devices are available which might upgrade the safety of your mower.
6. Use only authentic **HUSQVARNA** replacement parts to insure the safety and quality of your mower is maintained.
7. Safety decals should be replaced if they are missing or illegible. Decals may be purchased from your **HUSQVARNA** dealer.

### FRONT CASTER WHEELS

1. Mount front caster wheel assemblies. Installation includes fastening casters to front of the cutter deck using 3/8 x 1" hex head capscrews.

### FUEL TANK

1. Place fuel tank on tank support, making sure to get the studs through the slots on the top of the tank support. Place the 5/16" flat washer, spring, the other 5/16 flat washer and the 5/16" nut on the stud. Snug 5/16" nut, but do not over tighten.

### HANDLE ASSEMBLY

1. Align the upper mounting holes in handle with the upper hole in the tank support.
2. Install two 3/8" x 1" screws through matched holes and loosely install 3/8" nuts.
3. Align the lower holes and install hardware as above, tighten upper and lower hardware.

### LINKAGE INSTALLATION

1. Install drive linkage into the hole in the idler arm on the inside of the tank support. The drive linkages are fastened to the drive levers on the handle assembly. Secure the drive linkages to the idler arm by inserting a retaining ring through the small hole in the end of the drive linkage.
2. Install shifter to transmission with 1/4" x 1" screws.  
The shifter is located in the inner box and hardware is pre-assembled into the bracket on the transmission.
3. Install blade control rod into the bellcrank on the left side of the tank support. Secure rod with ring type retainer.
4. Refer to the section of this manual on adjustments for the proper adjustment of the linkages you are installing. The linkages were set at the factory but must be checked before operating mower to insure of the proper setting. Always check 100% of the adjustments before you operate the mower.
5. Connect the two halves of the wiring harness together. The four prong connectors have a locking tab that shows which way to line them up and guarantees that they are connected properly when the lock snaps.
6. Install the chute deflector to the side of the mower deck. Bolt it into place using the two 5/16" x 1" screws and nuts pre-assembled into the mounting tabs on the deck. Tighten the screws very securely with the chute completely covering the discharge opening and tight against the side of deck.

### THROTTLE INSTALLATION

1. Connect the throttle cable end to the throttle mechanism on engine, leaving the cable clamp loose. Push throttle lever on console completely forward. Then pull the cable through the clamp on engine and tighten the cable clamp. Move the throttle lever back and forth to ensure proper installation.

# For Husqvarna Parts Call 606-678-9623 or 606-561-4983

## Setup & Adjustments

### GAS LINE INSTALLATION

1. The gas line is factory installed on the engine. Attach loose end to fuel tank hose barb and secure with hose clamp.

### POSITIONING FRONT CASTER SPACERS

1. Using the cutting height chart, find the correct number of spacers to be placed under the caster swivel.

2. Remove the lynch pin and washer from the top of caster and reposition spacers to the desired cutting height from the chart. See figure # 2

### AXLE HEIGHT ADJUSTMENT

1. To adjust rear axle, stop engine and place drive levers in the neutral lock position, remove spark plug wire.

2. Remove lower belt shield from underside of rear deck for better access to axle adjustment bolts.

3. Loosen axle pivot bolts and axle adjustment bolts. See figure # 1.

4. Place a jack under center of rear deck raise the jack slightly so axle adjustment bolts may be removed.

5. With the jack raise or lower the rear deck to the desired position using the chart to ensure proper height. Reinstall the axle adjustment bolts and tighten.

A tapered punch may be used to help align the holes. See figure #1.

### NOTE:

It may be necessary to readjust drive and brake linkages.

### NOTE:

To achieve the best quality cut, the blades should be level with the ground or slightly tipped forward

### BRAKE ROD ADJUSTMENT

1. Make sure the rod is installed into the proper hole in the brake arm. The brake rod should be in bottom hole on the brake arm as shown below. **Never use the upper hole.** The proper adjustment can not be achieved in this position.

2. To increase braking. Turn the wing nut down on the brake rod. **Do not** turn the wingnut down too far as this will result a constant braking action and will excessively wear the brake band and cause premature failure.

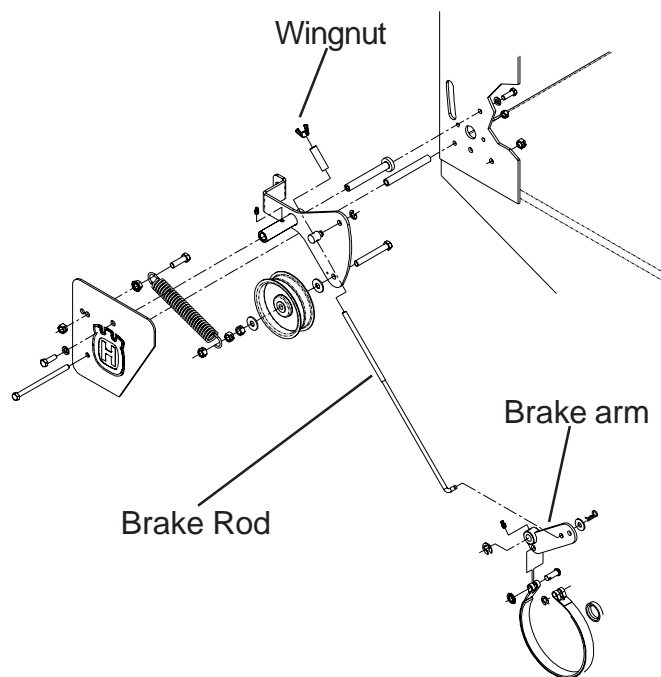

# For Husqvarna Parts Call 606-678-9623 or 606-561-4983

## Setup & Adjustments

### REAR AXLE HEIGHT ADJUSTMENT

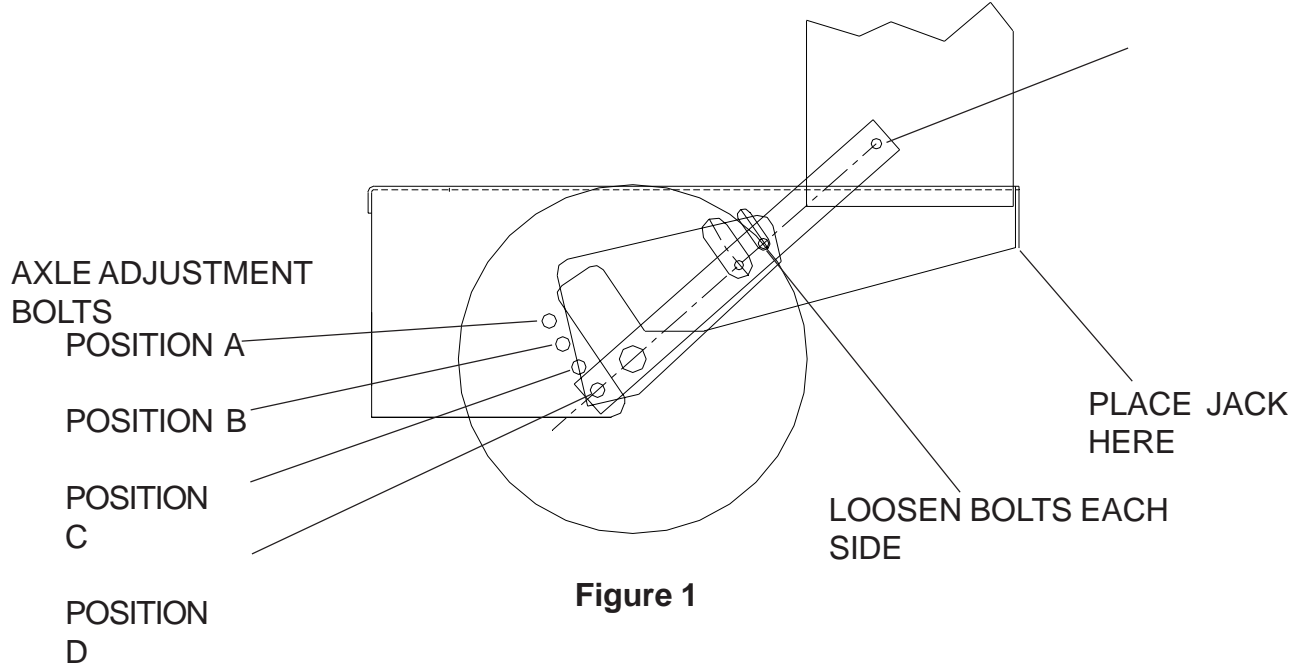

### CASTER HEIGHT ADJUSTMENT

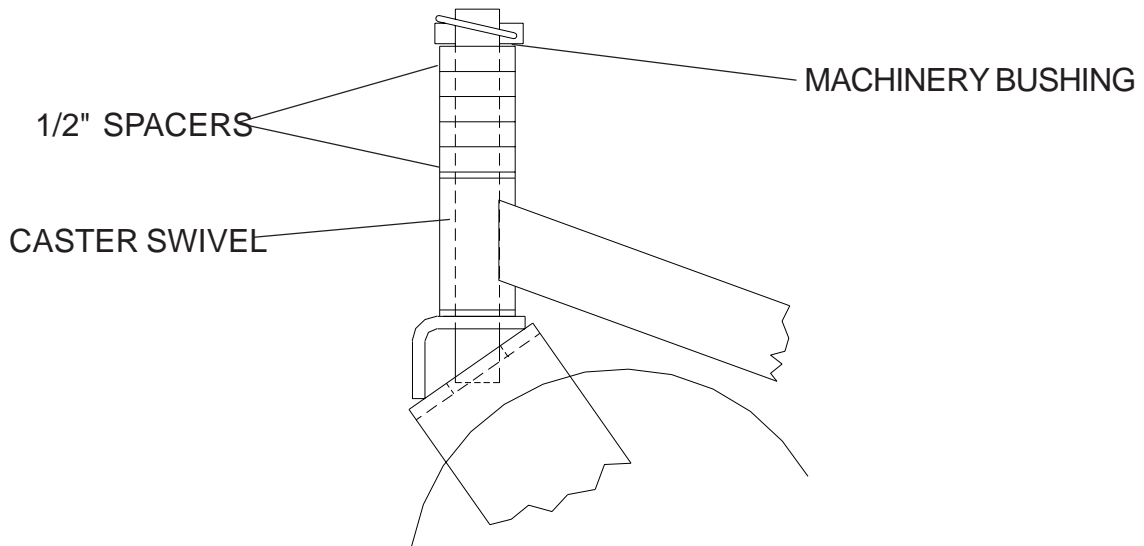

**Figure 2**

## Setup & Adjustments

### CUTTING HEIGHT ADJUSTMENT CHART

AXLE POSITION	NUMBER OF SPACERS BELOW CASTER ARM	NUMBER OF 1/4" BLADE SPACERS UNDER CUTTER HOUSING	CUTTING HEIGHT (IN INCHES)
A	0	4	1 1/2
		3	1 3/4
		2	2
		1	2 1/4
		0	2 1/2
	1	4	1 3/4
		3	2
		2	2 1/4
		1	2 1/2
		0	2 3/4
B	2	4	2 1/2
		3	2 3/4
		2	3
		1	3 1/4
		0	3 1/2
	3	4	3
		3	3 1/4
		2	3 1/2
		1	3 3/4
		0	4
C	3	4	3 1/4
		3	3 1/2
		2	3 3/4
		1	4
		0	4 1/4
	4	4	3 1/2
		3	3 3/4
		2	4
		1	4 1/4
		0	4 1/2
D	4	4	3 3/4
		3	4
		2	4 1/4
		1	4 1/2
		0	4 3/4
	5	4	4
		3	4 1/4
		2	4 1/2
		1	4 3/4
		0	5

1. To quickly achieve small changes in cutting heights, move the spacers from under the cutter housing to above the cutter pulley. (Each spacer moved will give an additional 1/4" of cutting height).

USE ONLY 4 BLADE SPACERS MAXIMUM

## Setup & Adjustments

### BRAKE / TRACTION ADJUSTMENT

1. Disconnect the brake linkage from the brake band arm.
2. With the mower in gear, place the drive levers in the drive position. Firmly pull back on the handles until the tires slide to seat the drive belts into the pulleys.
3. Measure the distance between the back drive lever slot and the neutral bail. It should be between  $3/16$  and  $1/4$ " but not exceeding  $1/4$ ". See Figure #3.
4. If the clearance is less than  $3/16$ ", disconnect the drive lever from the idler arm by removing the retaining ring.
5. Adjust the drive linkage to the proper clearance by screwing it into the yoke at the drive lever end of the linkage. This will achieve proper clearance if the distance is less than  $3/16$ ". Screw the linkage out if it is greater than  $1/4$ ".

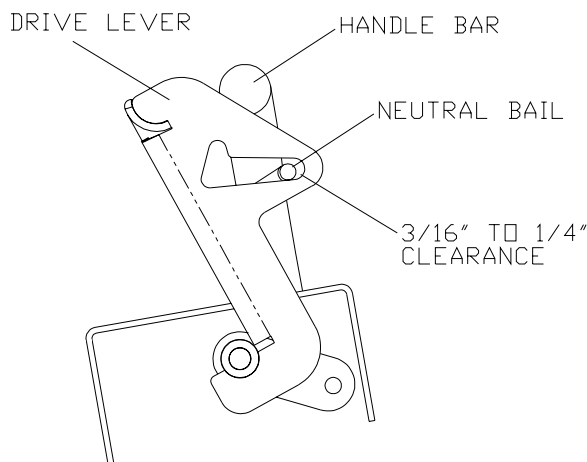

Figure 3

#### NOTE:

More or less brake pressure may be desired depending on the operator or conditions of operation. To increase pressure tighten the wing nut on the brake linkage.

### OPERATOR PRESENCE SWITCH ADJUSTMENT

The operator presence switches can be adjusted by loosening the screws on the back side of the console and sliding the switch left or right. The O.P. switch plunger should just come in contact with the O.P. lever when the operator presence levers are released.

### BLADE SWITCH ADJUSTMENT

The blade engagement switch can be adjusted by loosening the screws on the blade engagement bracket and moving the switch up or down. The blade switch should be adjusted so the plunger is fully depressed when the engagement lever is fully disengaged.

### ADJUSTMENTS - DRIVE BELTS

For all drive belts, tension should be set so that belt vibration is minimized or eliminated when belts are moving during normal operation. A properly tensioned belt should have  $1/4$ " to  $3/8$ " deflection at the center of belt span between pulleys when blades are engaged. Blade drive belt tension is preset at the factory.

#### NOTE:

**DO NOT** over tighten belt. Excessive tension will decrease belt and spindle bearing life.

### BLADE DRIVE BELT ADJUSTMENTS

#### WARNING

**BEFORE PERFORMING ADJUSTMENTS ON BLADE BELT, TURN MOWER OFF, CLOSE FUEL VALVE, AND DISCONNECT SPARK PLUG WIRE.**

1. Remove front deck belt shield.
2. Loosen whiz nut on turnbuckle.
3. Set belt tension when engagement lever is in the engaged position.
4. To increase belt tension rotate turnbuckle toward the rear of the mower until desired tension is gained. Do not over tighten belts, too much tension will reduce belt and spindle bearing life. See figure # 6
5. Tighten whiz nut on turnbuckle and install belt shield.

## AUXILIARY BLADE DRIVE BELT (48" MODELS ONLY)

To adjust tension of the auxiliary belt rotate nut on linkage that is attached to deck strap located on the right side of cutter deck. See Figure 6.

## TRANSMISSION DRIVE BELT

To increase the tension of the transmission belt, loosen the nut on the underside of the transmission idler pulley located under the rear deck, slide the idler assembly inward to increase tension and tighten the nut to secure. See figures 4 & 5.

## BELT GUIDES

Belt guides under rear deck are adjusted as shown in figures 4 and 5

**NOTE: The blades should come to a stop from maximum speed within 7 seconds after disengaging.**

## BLADE ENGAGEMENT LEVER

The blade engagement lever needs to be adjusted so the lever does not come in contact with control panel when the lever is in the off position.

To adjust, remove the clevis pin from the yoke and adjust by turning the yoke. The clevis pin connects the blade engagement lever to the yoke, and the yoke is connected to the blade engagement rod that runs to the bellcrank on the rear deck.

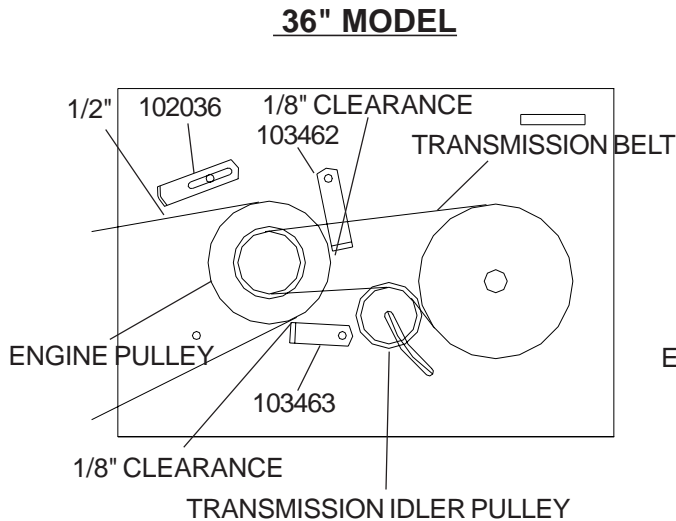

Figure 4

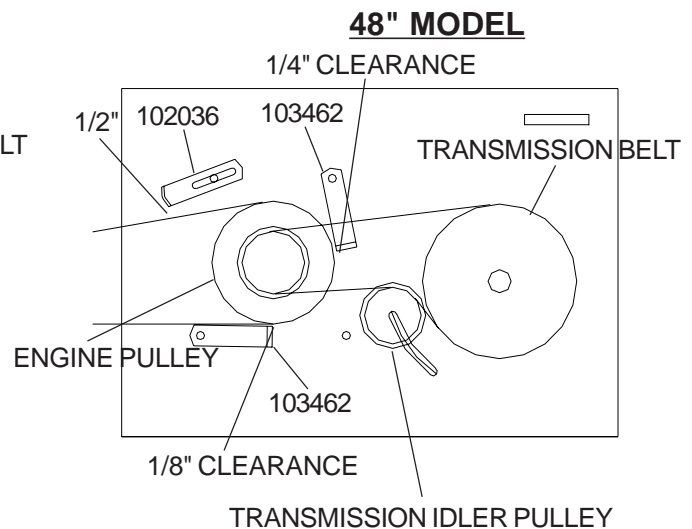

Figure 5

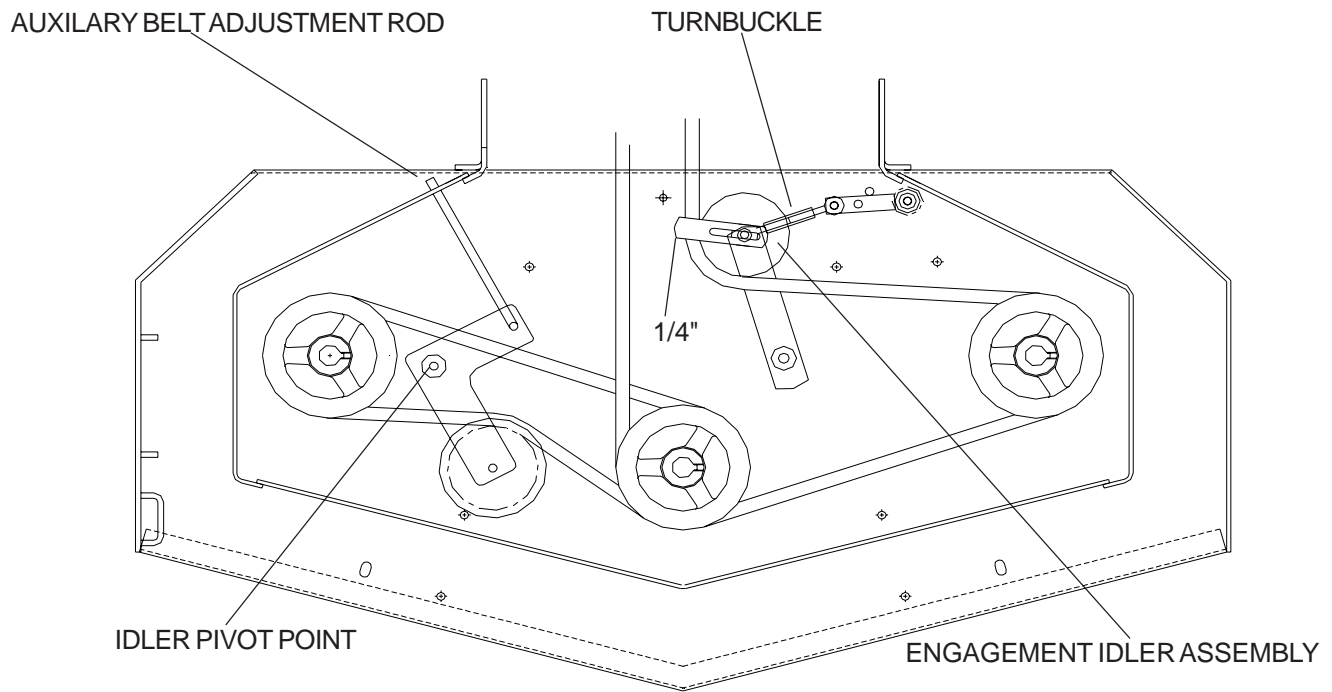

Figure 6

## BEFORE OPERATING

Be thoroughly familiar with all controls and how to use them before operating the mower. Know beforehand how to stop the engine, drive wheels, and mower blades in preparation for possible emergency.

## EMERGENCY STOP

Pull both drive levers firmly against handle grips and hold them securely in place. Use thumbs to lift the neutral bail up into the neutral slot. Then stop engine by pulling throttle control back and shut off the key switch. See figure # 7.

## NORMAL OPERATING STOP

1. Pull both drive levers firmly toward the handle grips to stop forward motion.
2. Use thumbs to lift neutral bail into the neutral slots.
3. Move the throttle control to the slow position.
4. Move blade engagement lever to the off position.
5. Move shift lever to the neutral position.
6. Stop engine by turning the key switch to the off position.

**NOTE**  
**CLOSE FUEL VALVE AT THE END OF EACH MOWING JOB !!**

## PRE-START CHECKLIST

Make the following checks and perform the services as required before each start up.

1. If required make cutting height adjustments and drive linkage adjustments. Refer to pages 6, 7, and 8
2. Check tires for proper inflation (front caster tire pressure to be 50 lbs max. / rear tire pressure to be 14 lbs max.
3. Check guards, deflectors, and covers to make sure all are in place and secure.
4. Check blade belts for wear and correct tension if worn or damaged, replace with original part.
5. Clean interior and exterior surfaces of the cutting deck and clean engine of any accumulation of dirt or debris. Keep engine air intake clear at all times.
6. Check engine oil add if needed (do not over-fill)  
refer to engine manual for oil specs.
7. Add fuel to tank after pushing the mower outside where fumes can dissipate. Make sure cap is tight after refueling.

**NOTE**  
**DO NOT ADD FUEL WHILE ENGINE IS RUNNING OR WHILE ENGINE IS HOT.**

## Hydro Intermediate Walk Behind

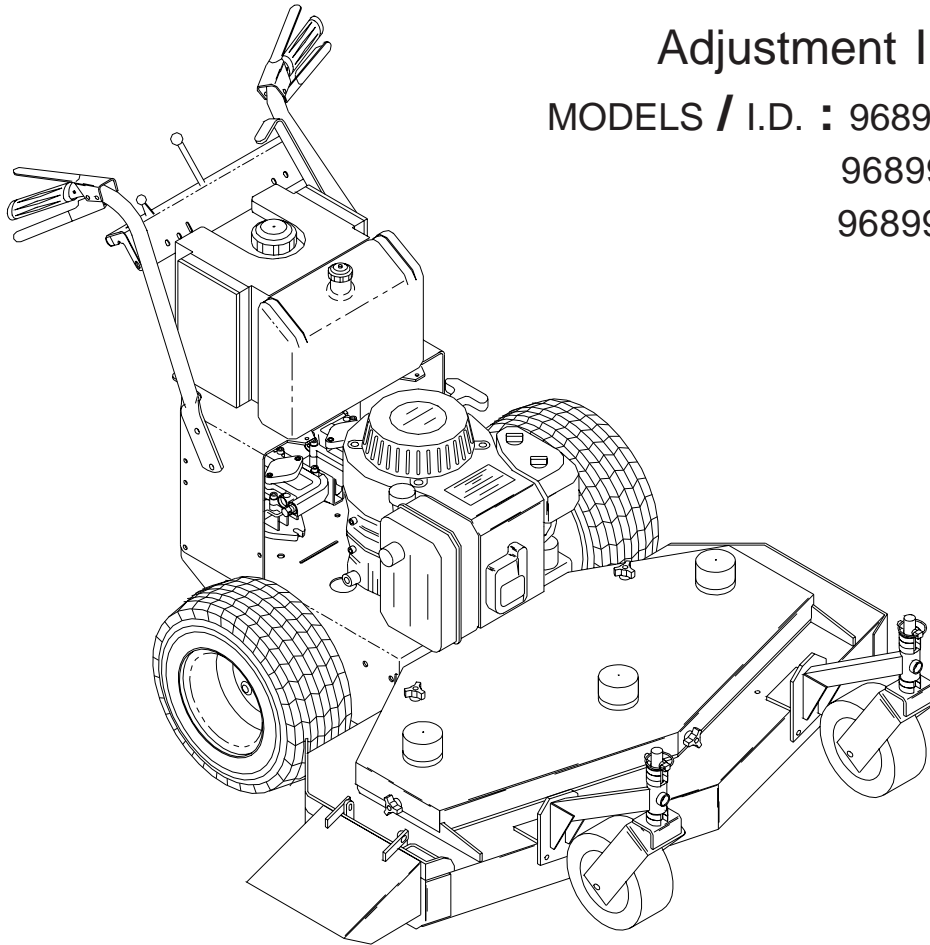

Adjustment Instructions for:

MODELS / I.D. : 968999105 / WH3614A

968999111 / WH3615A

968999106 / WH4817A

---

### CUTTING HEIGHT

1. Before changing cutting heights make sure the blades are off, key switch is off, and remove spark plug wire or wires.
2. Cutting height ranges from 1 1/2" to 5" in 1/4" increments.
3. Cutting height can be changed three ways. Move one "C" spacer on the front casters, change the blade spacers, or move the wheel motor assemblies.
4. a. To change heights on the rear deck loosen, do not remove, the top two carriage bolts on both sides. (see fig. 1a)  
b. Place a jack under the center of the rear deck remove the bottom two nuts on both sides. Then remove the bottom two bolts both sides. (May have to raise the jack slightly to remove bolts.)(see fig. 1b)  
c. With the jack raise or lower the rear deck to the desired position using the chart, on page 7, to ensure proper height.



d. Reinstall the bottom two bolts on both sides. (A tapered punch may be needed to help align the holes.)

e. Retighten all four bolts both sides and remove jack.

5. Using the chart (on page 7), find the correct number of spacers to be placed under the caster swivel. (see fig. 2)

**NOTE:** To achieve the best quality cut, the blades should be level with the ground or slightly tipped forward.

## REAR DECK ADJUSTMENT

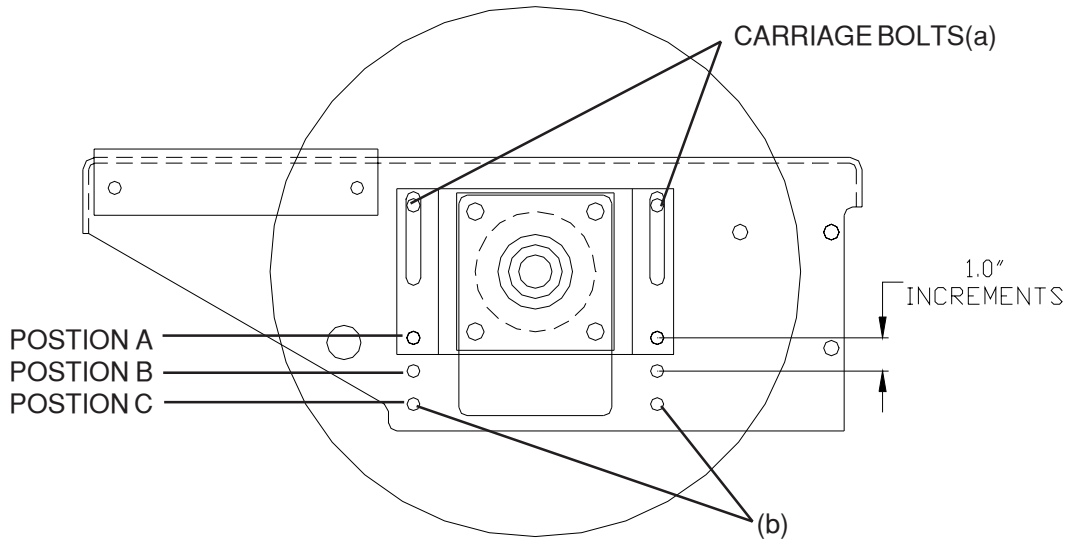

Figure 1

## CASTER HEIGHT ADJUSTMENT

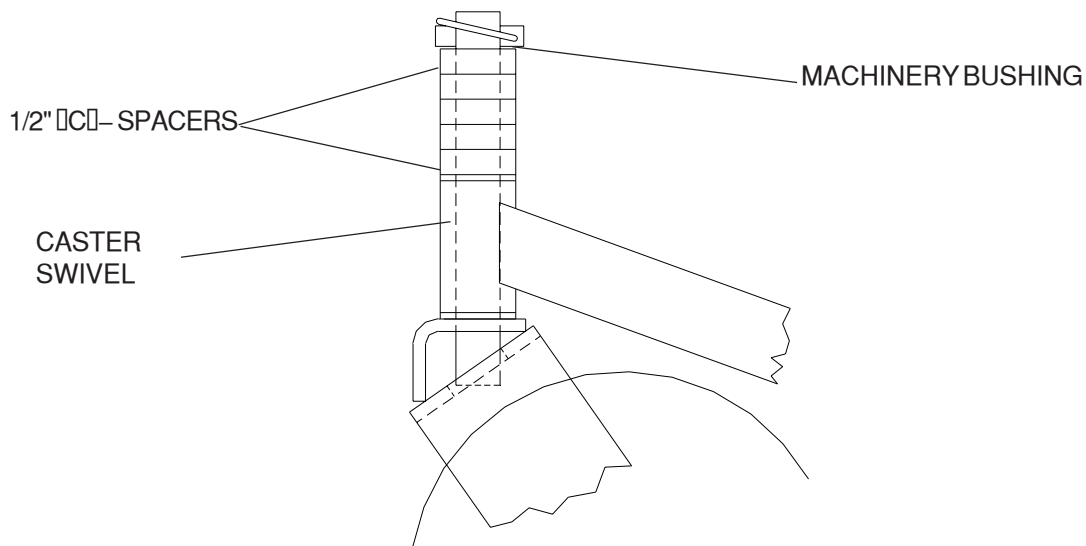

Figure 2

**CUTTING HEIGHT ADJUSTMENT CHART**

AXLE POSITION	NUMBER OF SPACERS BELOW CASTER ARM	NUMBER OF 1/4" BLADE SPACERS UNDER CUTTER HOUSING	CUTTING HEIGHT (IN INCHES)
A	0	4	1 1/2
		3	1 3/4
		2	2
		1	2 1/4
		0	2 1/2
	1	4	2
		3	2 1/4
		2	2 1/2
		1	2 3/4
		0	3
B	2	4	2 1/2
		3	2 3/4
		2	3
		1	3 1/4
		0	3 1/2
	3	4	3
		3	3 1/4
		2	3 1/2
		1	3 3/4
		0	4
C	4	4	3 1/2
		3	3 3/4
		2	4
		1	4 1/4
		0	4 1/2
	5	4	4
		3	4 1/4
		2	4 1/2
		1	4 3/4
		0	5

Note: To quickly achieve small changes in cutting heights, move the spacers from under the cutter housing to above the cutter pulley. (Each spacer moved will give an additional 1/4" of cutting height).

**USE ONLY 4 BLADE SPACERS MAXIMUM**

**MOTION CONTROL ADJUSTMENT**

1. This adjustment must be made with the drive wheels rotating. Raise rear of the unit and block it up so the wheels are free to rotate. CAUTION: Keep hands, feet and clothing away from rotating tires.
2. It will be necessary to make this adjustment with the reverse detents disconnected.
3. With the ground speed lever in neutral or stop position, start the engine.
4. The thumb latches should be unlocked.
5. Turn the adjusting nut the proper direction until the wheel stops rotating. This is your neutral position, repeat on other side. (see fig. 3)
6. After the neutral position is adjusted. You will need to readjust the short linkage. (see fig. 3)
7. Remove the two hairpins, swing the linkage out of the control lever and the thumb latch. (see fig.3)

8. Turn the short linkage the proper direction in the swivel, so that when the thumb latch is engaged the wheel doesn't turn (or it is in neutral). Reinstall the hairpins and repeat on other side. (see fig. 3)
9. After these adjustments have been made it will be necessary to adjust the reverse detent. (See reverse spring detent adjustment)

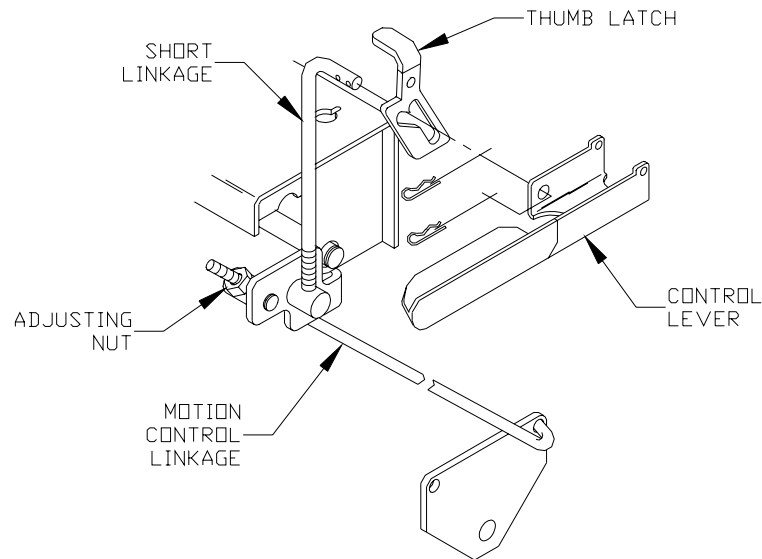

Figure 3

## REVERSE SPRING DETENT ADJUSTMENT

1. To check if your reverse spring detent adjustment is set right. Make sure your ground speed lever is pulled back to the neutral position. Release the thumb latches (both sides) and pull up on the control levers at the same time. Then release the levers, it should return to neutral. If it does not, the following adjustments need to be made.
2. Stop engine and remove key.
3. Ground speed lever should be in the neutral or stop position and the thumb latches unlocked.
4. Loosen the two 1/4" bolts holding the reverse detent bracket. Slide the bracket up or down till it just touches the "L" shape stop under the console. Holding the bracket against the stop retighten the two 1/4" bolts. (Repeat on other side if needed.) (see fig. 4)

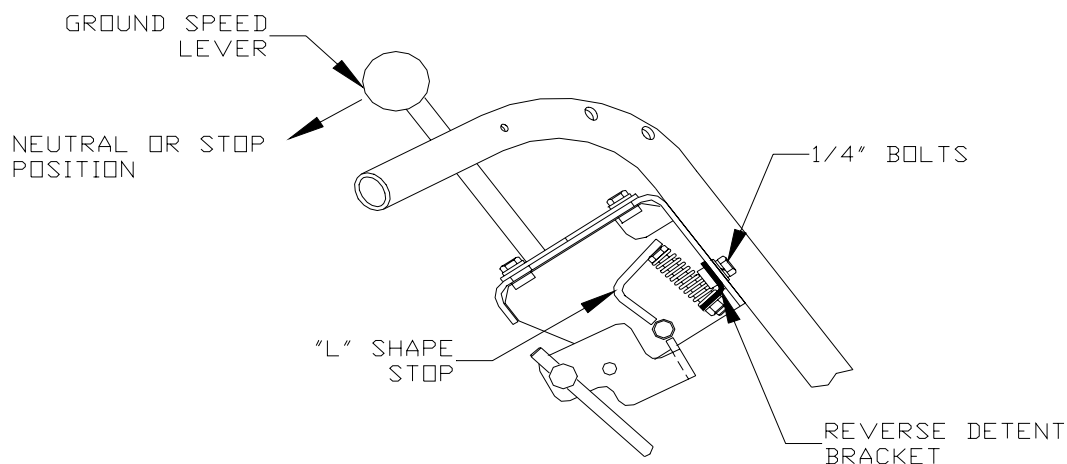

Figure 4

(Right side cut away view of console.)

### BLADE DRIVE BELT ADJUSTMENT

1. Before performing adjustments on blade belt, turn the mower off and disconnect spark plug wire or wires.
2. Remove front deck belt shield.
3. Loosen nut on turnbuckle.
4. Set belt tension when blade engagement lever is in the engaged position.
5. To increase belt tension rotate turnbuckle toward the rear of the mower until desired tension is gained. Do not over tighten belts, to much tension will reduce belt and spindle bearing life. (see fig. 5)

### AUXILIARY BLADE BELT

1. Before performing adjustments on blade belt, turn the mower off and disconnect spark plug wire or wires.
2. To adjust tension on the auxiliary belt rotate nut on linkage that is attached to deck strap located on the right side of cutter deck. (see fig. 5)

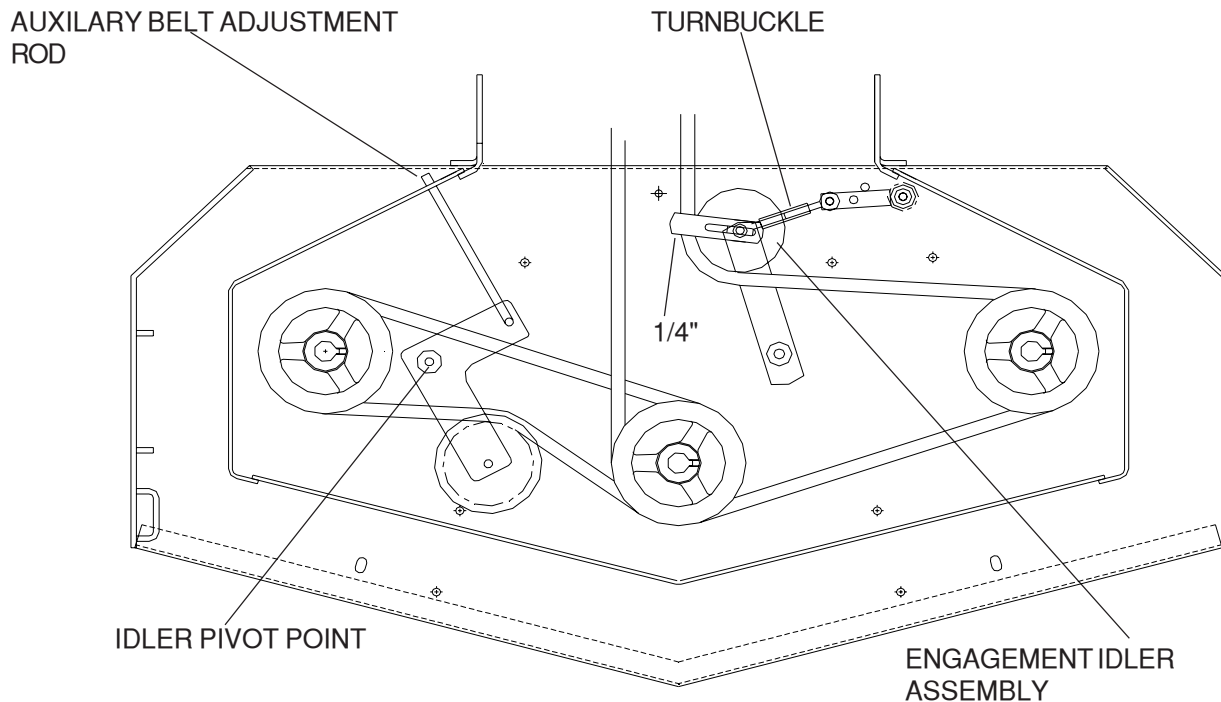

Figure 5

## ENGINE BELT GUIDES

1. Before performing adjustments on belt guides, turn the mower off and disconnect spark plug wire or wires.
2. Belt guides under the engine should be adjusted as shown in figure 6.

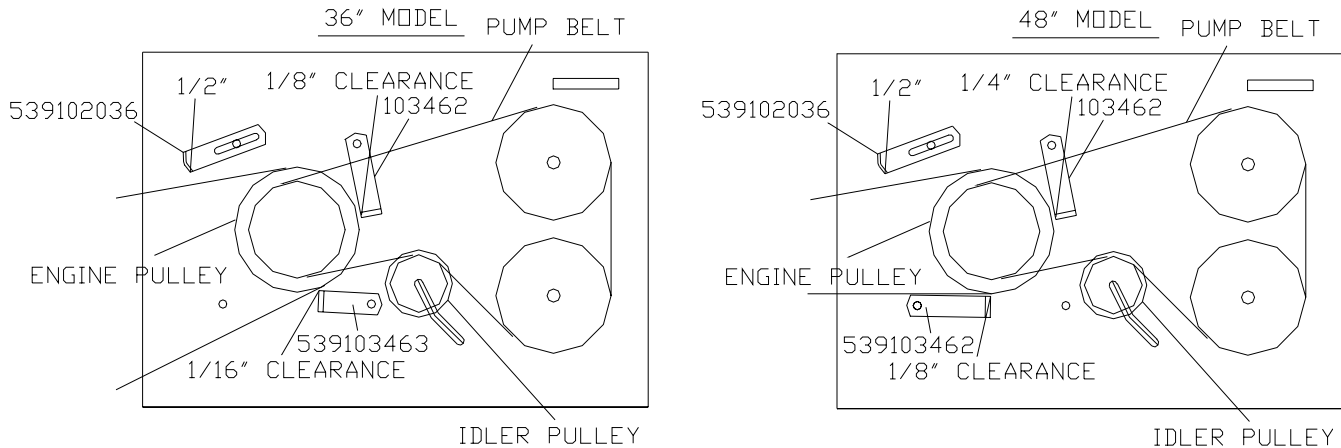

Figure 6

## PUMP BELT

1. Before performing adjustments on pump belt, turn the mower off and disconnect spark plug wire or wires.
2. Check tension on the belt. If it feels loose adjustment will need to be made.
3. Loosen the nut on the bottom of the idler pulley.
4. Slide the idler pulley against the belt, retighten the nut while applying pressure to the idler pulley. (see fig. 6)

## INTERLOCK SAFETY SYSTEM

The interlock modules function is to prevent the engine from starting if the blade and/or ground speed lever are engaged. It also causes engine shutdown if the operator falls from, or attempts to leave the operator position while the blades or ground speed lever are engaged. After the engine starts, the operator must hold either the left or right O.P. lever down before engaging the blades or moving the ground speed lever. If neither O.P. lever is held the engine will stop. Check the function of the safety electrical system on a regular basis.

1. Engine must kill if blades are engaged without O.P. levers held down.
2. Engine must kill if ground speed lever is taken out of neutral without holding down O.P. levers.
3. Engine must not start unless blades are off and ground speed lever is in the neutral position.
4. Do not operate the mower if the interlock safety system allows operation or starting in any unsafe condition.

## ETS Hydro Intermediate Walk Behind

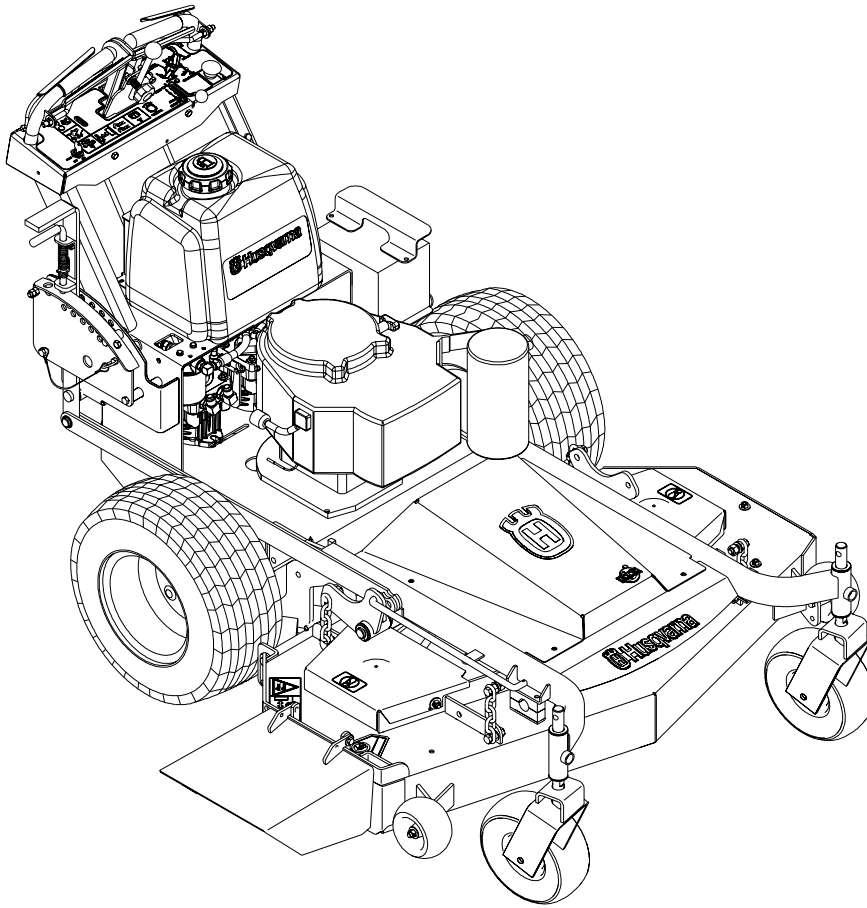

### Models:

968999127 / WHF4215ETS

968999129 / WHF4818ETS

968999130 / WHF5218ETS

## CUTTING HEIGHT:

1. Stop the mower and disengage the blades.
2. Raise the deck height lever to the transport position.
3. Remove the height adjustment pin and place it in the desired cutting height hole. Move deck height lever down onto the pin and mow. NOTE: anti-scalp rollers must be in the proper position for maximum deck floatation. See the decal on the front deck.

## MOWER DECK LEVELING:

1. Position mower on a flat surface and stop engine.
2. Check the tire pressure of all four tires. Inflation should be 15 psi.
3. Place two 2x4's on edge under the cutting deck from front to rear and lower the deck down onto the 2x4's.
4. Adjust the four upper chain bolts "H" to the center of the slot in the deck lift arms (See Fig 2). NOTE: make sure deck lift blocks are tightly bolted to the frame .
5. Check chains for equal tension. If unequal, adjust upper chain bolt in slot.
6. Place deck in the 5" cutting height and measure from the cutting edge of the blade to a flat surface to check deck cutting height.

## MOTION CONTROL ADJUSTMENTS

1. This Adjustment must be made with the drive wheels rotating. Raise rear of the unit and block it up so the wheels are free to rotate. CAUTION: Keep hands, feet and clothing away from rotating tires.
2. With the ground speed lever in the neutral position, start the engine.
3. Lift the neutral bail into the neutral slots in the drive levers.
4. Adjust the drive linkages by loosening or tightening the nut on the bottom of the drive linkage until the wheels stop.
5. With 2 9/16" wrenches, adjust the reverse detent springs on the pump arms so that the head of the bolt is approximately 1/16" from the top of the rear deck.
6. Push the ground speed lever forward to full speed and pull back to neutral position to be sure that the wheels stop. This should be done several times and any readjustments made that are required.

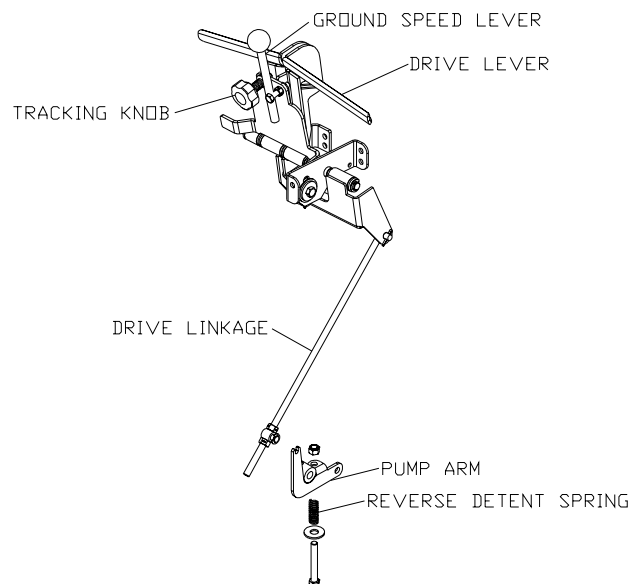

## ADJUSTMENTS

### FRONT DECK BELT ROUTING:

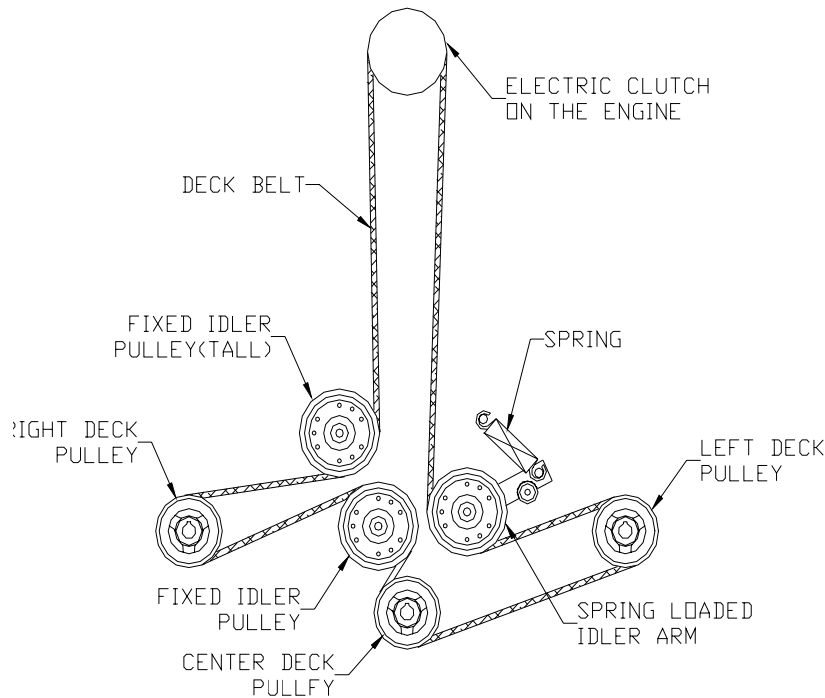

FIGURE 3

### PUMP BELT

1. Before performing adjustments on pump belt, turn the mower off and disconnect spark plug wire or wires.
2. Check tension on the belt. If it feels loose adjustment will need to be made.
3. Loosen the nut on the bottom of the idler pulley.
4. Slide the idler pulley against the belt, retighten the nut while applying pressure to the idler pulley. (see fig. 6)

### INTERLOCK SAFETY SYSTEM

The interlock modules function is to prevent the engine from starting if the blade and/or ground speed lever are engaged. It also causes engine shutdown if the operator falls from, or attempts to leave the operator position while the blades or ground speed lever are engaged. After the engine starts, the operator must hold either the left or right O.P. lever down before engaging the blades or moving the ground speed lever. If neither O.P. lever is held the engine will stop. Check the function of the safety electrical system on a regular basis.

1. Engine must kill if blades are engaged without at least one O.P. lever held down.
2. Engine must kill if ground speed lever is taken out of neutral without holding down at least one O.P. lever.
3. Engine must not start unless blades are off and ground speed lever is in the neutral position.
4. Do not operate the mower if the interlock safety system allows operation or starting in any unsafe condition.



## Mid Mount Zero Turn Riders 42" & 48"

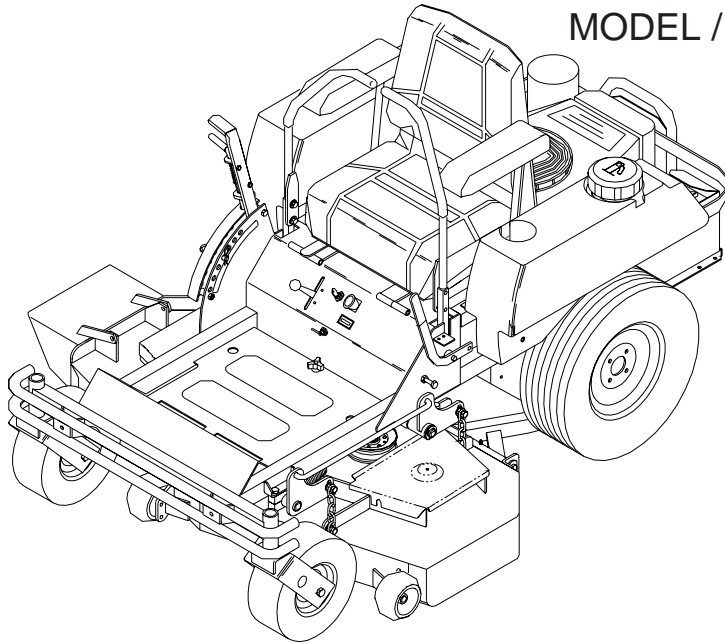

Setup Instructions for:  
MODEL / I.D. : 968999157 / ZTHKH4818A  
968999158 / ZTHKH4820A  
968999167 / ZTHKW4218A  
968999168 / ZTHKW4818A  
968999169 / ZTHKW4821A

### ADJUSTMENTS

#### PARK BRAKE:

1. Stop engine and remove key. While the park brake lever "A" is in the on position. The distance between the swivel "C" and the bolt head "B" should be 3/8" to 1/2" approximately. (See Fig. 2)
2. If adjustment is needed, using two 1/2" wrenches, loosen the nut "F" above the turnbuckle "G" while holding the turnbuckle "G" from turning. After the nut "F" is loose and out of the way. While holding the bolt head "B" from turning. Turn the turnbuckle "G" the proper direction to lengthen the distance or to shorten the distance. After the proper distance is obtained retighten the nut "F" against the turnbuckle "G".
3. While the park brake lever "A" is still in the on position, measure the length of the spring "D". Should measure 2". (See Fig. 2)
4. If adjustment is needed loosen or tighten the nut "E" below the spring "D". While holding the turnbuckle "G" to keep the assembly from turning.

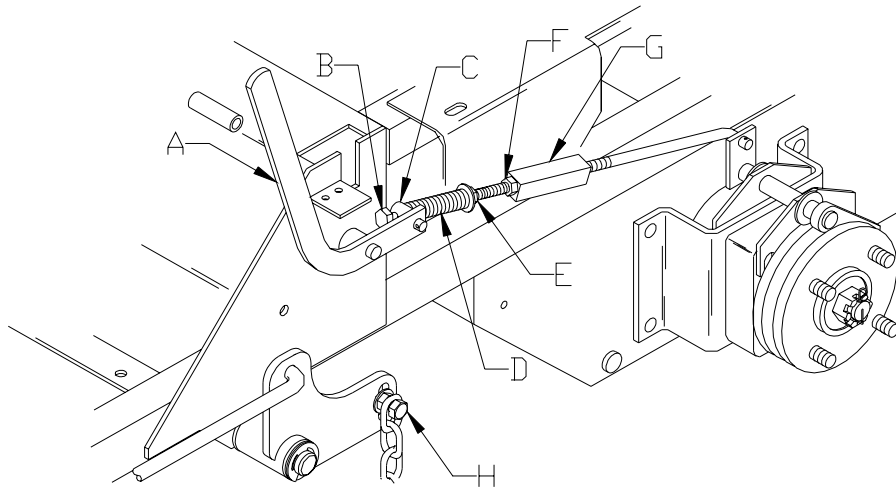

**FIGURE 2**

**CUTTING HEIGHT:**

1. Stop the mower and disengage the blades.
2. Raise the deck height lever to the transport position.
3. Remove the height adjustment pin and place it in the desired cutting height hole. Move deck height lever down onto the pin and mow. NOTE: anti-scalp rollers must be in the proper position for maximum deck floatation. See the decal on the front deck.

**MOWER DECK LEVELING:**

1. Position mower on a flat surface and stop engine.
2. Check the tire pressure of all four tires. Inflation should be 15 psi.
3. Place two 2x4's on edge under the cutting deck from front to rear and lower the deck down onto the 2x4's.
4. Adjust the four upper chain bolts "H" to the center of the slot in the deck lift arms (See Fig 2). NOTE: make sure deck lift blocks are tightly bolted to the frame .
5. Check chains for equal tension. If unequal, adjust upper chain bolt in slot.
6. Place deck in the 5" cutting height and measure from the cutting edge of the blade to a flat surface to check deck cutting height.

## FRONT DECK BELT ROUTING: (See Fig. 4)

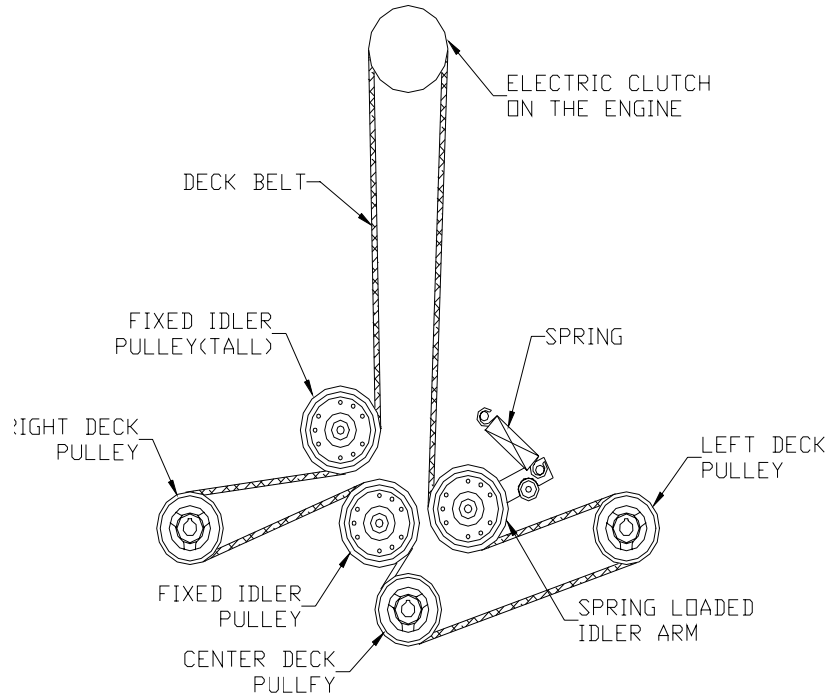

## THROTTLE LEVER TENSION:

1. Stop engine and remove key.
2. If throttle lever becomes loose, tension may be adjusted by tightening the pivot bolt. The pivot bolt holds the throttle arm to the throttle mounting bracket which is located under the console. Access is gained by removing the foot plate and the kick plate. See page 3.

## REVERSE SPRING DETENT ADJUSTMENT:

1. Stop engine and remove key.
2. Pull the motion control lever back to the reverse position and release the lever. When the lever stops it should be in line with the neutral slot, so you can rotate the lever out without hitting the side of the console.
3. If adjustment is needed put the seat in the rear slide position, tilt seat forward, remove seat lanyard from seat frame, and rotate seat forward to rest on the frame.
4. On the back of the console where the spring is fastened. Loosen 3/8" nut and bolt enough to allow the bolt to slide in the slot. (See Fig. 5a)
5. Rotate the motion control lever out into the neutral slot. While the lever is swung out pull it against the back edge of the neutral slot. Holding the lever adjust the spring by sliding the bolt in the slot to remove all the slop and retighten the 3/8" nut and bolt. (Repeat steps on other side if needed.) (See Fig. 5a)
6. Check your adjustment by repeating step two.
7. If no more adjustment is needed refasten the seat lanyard to the seat frame.

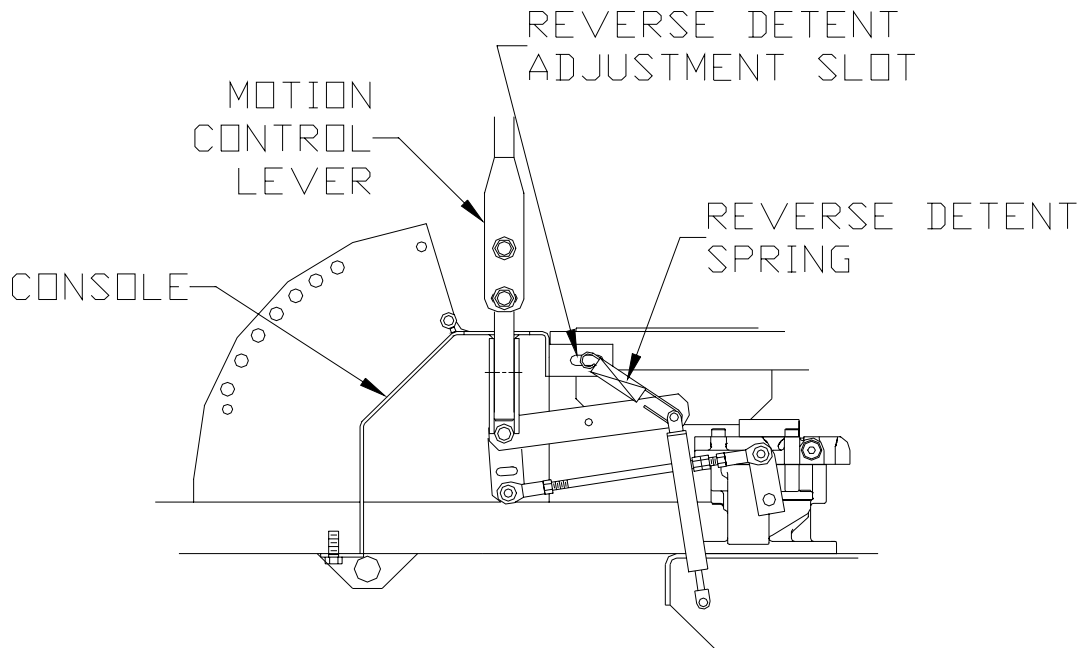

Figure 5a  
(Left side cut away view)

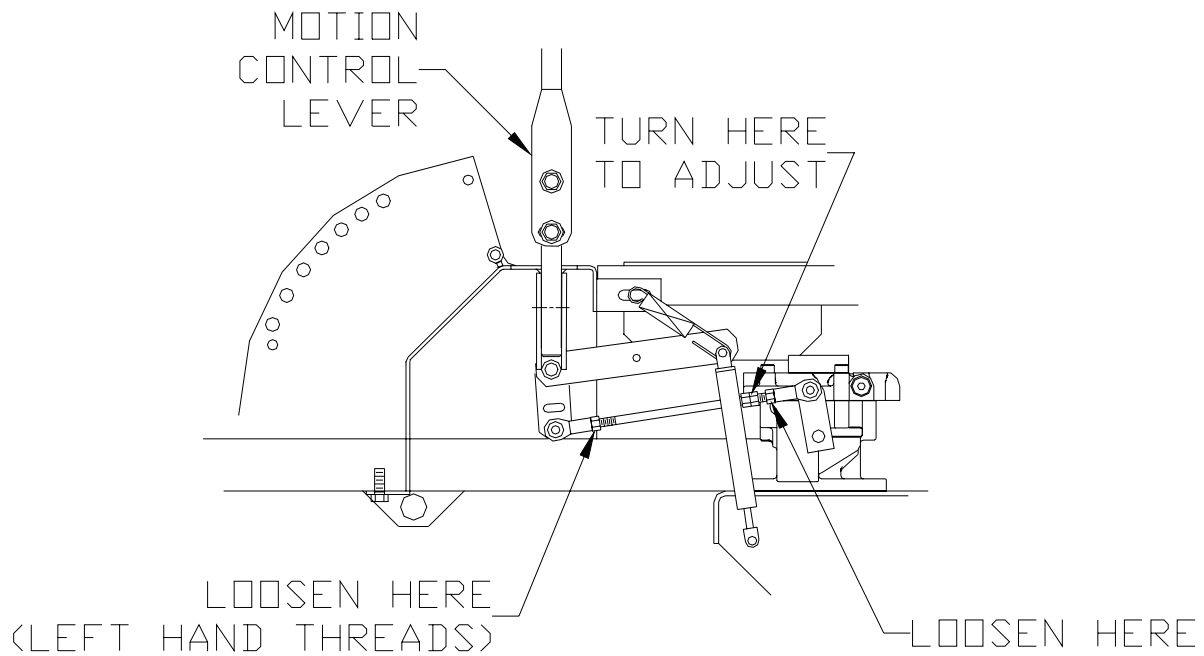

Figure 5b  
(Left side cut away view)

## ADJUSTMENTS

### MOTION CONTROL LINKAGE ADJUSTMENT:

1. This adjustment must be made with the drive wheels rotating. Raise rear of the unit and block it up so the wheels are free to rotate. **CAUTION: Keep hands, feet and clothing away from rotating tires.**
2. Tilt seat forward and remove the seat lanyard from seat so the seat can rotate down onto the frame. Make sure the seat is adjusted toward the rear of the unit so it clears the controls on the console.
3. Place a 2x4 board approximately 10 to 12 inches long between the foot plate and the center of the seat to engage the seat safety switch. **NOTE:** You may want to cover the end of the 2x4 with a rag to protect the seat from marring.
4. Loosen the nuts directly behind each ball joint on both rods that connect the pump arm to the motion control assemblies. (See Fig 5b )
5. Start the engine. The park brake must be engaged and the motion control levers must be in the neutral slot (See figure 6 page 10) to start the engine. Run engine at approximately 1/2 throttle.
6. Release park brake to allow wheels to rotate. **CAUTION:** Keep hands, feet and clothing away from rotating tires.
7. Begin with either side and put the motion control lever into the neutral position. Adjust the motion control linkage by rotating the double nuts on the rod in the proper direction until the wheel stops rotating (See Fig 5b ).  
Move the motion control lever forward then into the neutral position and place it into the neutral slot. The wheel must be stopped completely at this point. Now do the same in reverse and release the lever. The lever should return to neutral on its own. If not see reverse spring detent adjustment section.
8. Run engine at full throttle to make sure wheels do not rotate. Readjust if any rotation occurs.
9. Repeat on the opposite side and tighten nuts against ball joints.
10. Remove the 2x4 board and make sure the seat wiring is connected to the wiring harness.  
**WARNING:** Seat must be connected for safety interlock system to properly function.

## Mid Mount Zero Turn Riders 52" & 61" Generation 2

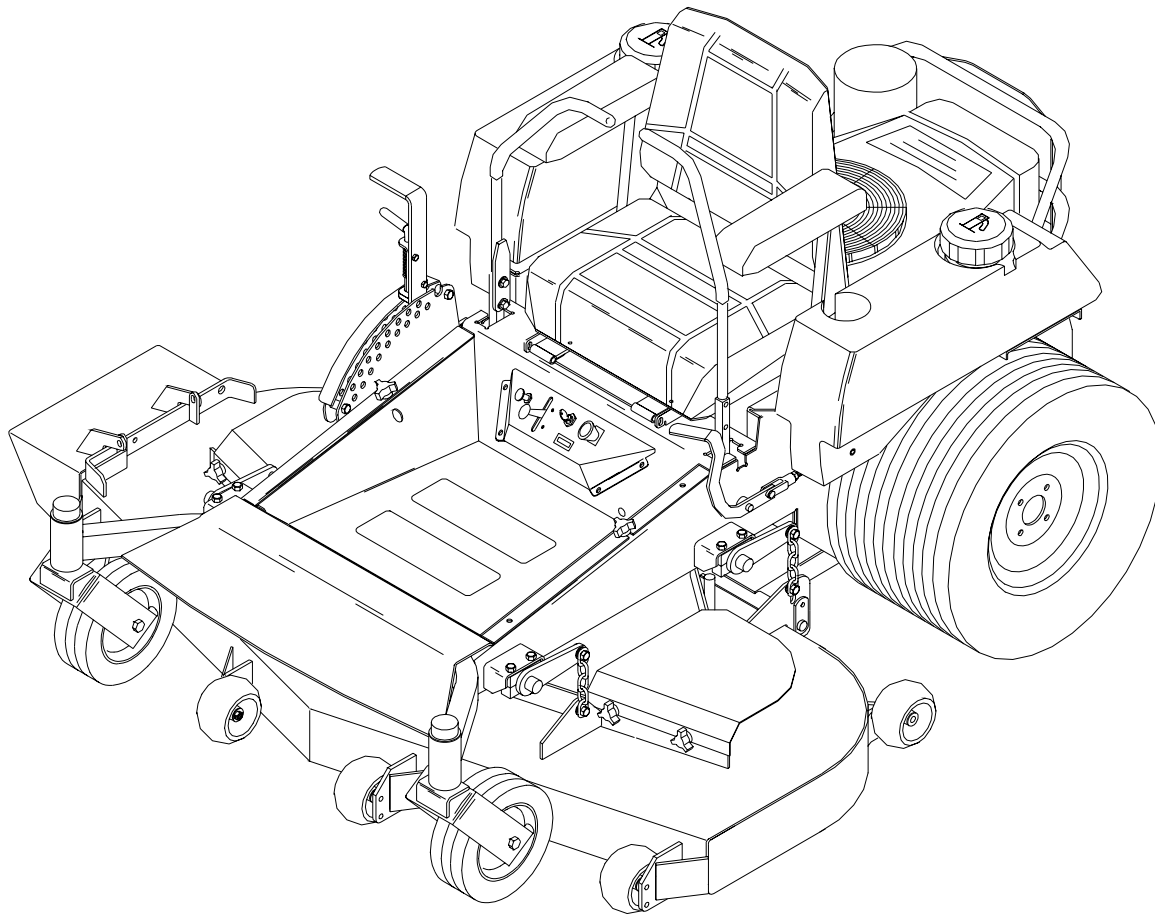

### Adjustment instructions for:

#### Models:

968999159 / ZTH5221KAA  
968999160 / ZTH5223KAA  
968999161 / ZTH5223KOA  
968999162 / ZTH5223KOLA  
968999163 / ZTH5225KOA  
968999165 / ZTH6125KOA  
968999166 / ZTH6125KAA  
968999173 / ZTH5225KAA

## Adjustments

### Cutting Height

Stop the mower and disengage the blades.

Raise the deck height lever to the transport position.

Remove the height adjustment pin and place it in the desired cutting height hole. Lower the lift lever down onto pin. NOTE: Anti-scalp rollers must be in the proper position for maximum deck floatation. See the decal on the front deck for proper settings. FIG - 5

### Mower Deck Leveling

Position machine on a flat surface. Preferably level concrete.

Check the tire pressure in all four tires. Inflation should be 15 psi.

Place 2x4's on edge under the cutting deck from front to rear and lower the deck down onto 2x4's.

Adjust the four lower chain bolts to the center slots on the deck. FIG - 6 NOTE: Make sure the lift blocks under the frame are tightly bolted to the frame.

Check the chains for equal tension. If unequal adjust lower chain bolt in slot.

Place the deck in the 6" cutting height and measure from the cutting edge of the blade to the flat level surface to check the deck cutting height.

### Throttle Lever Tension

Stop engine and remove key.

Throttle lever tension may be adjusted by tightening the pivot bolt. The pivot bolt secures the throttle arm to the mounting bracket which is mounted to the console. Access is gained by removing the console.

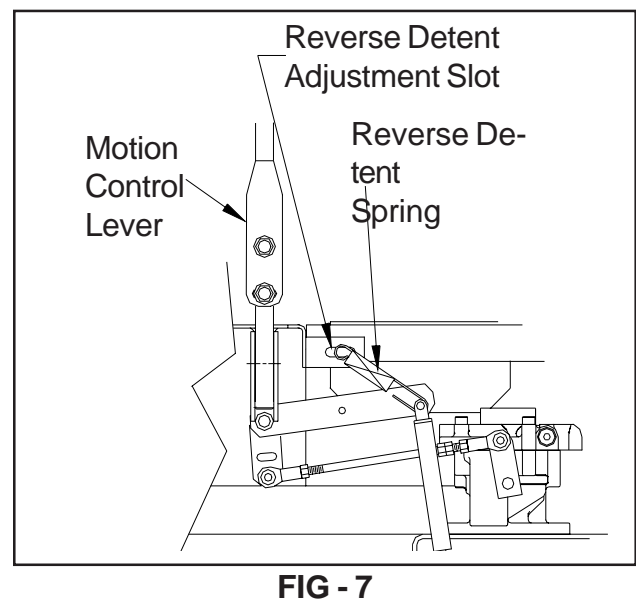
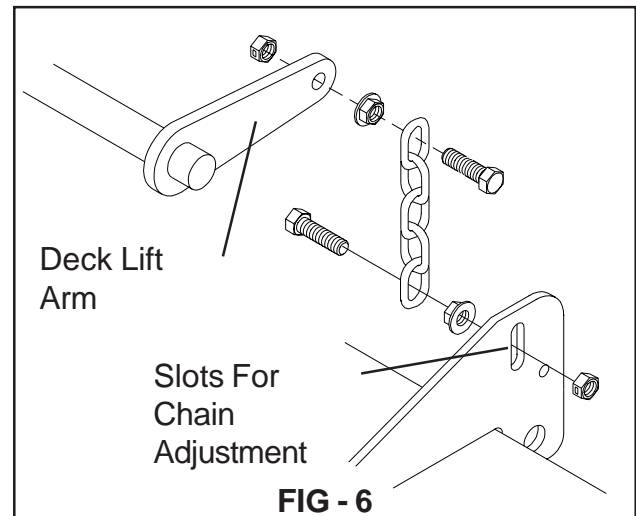
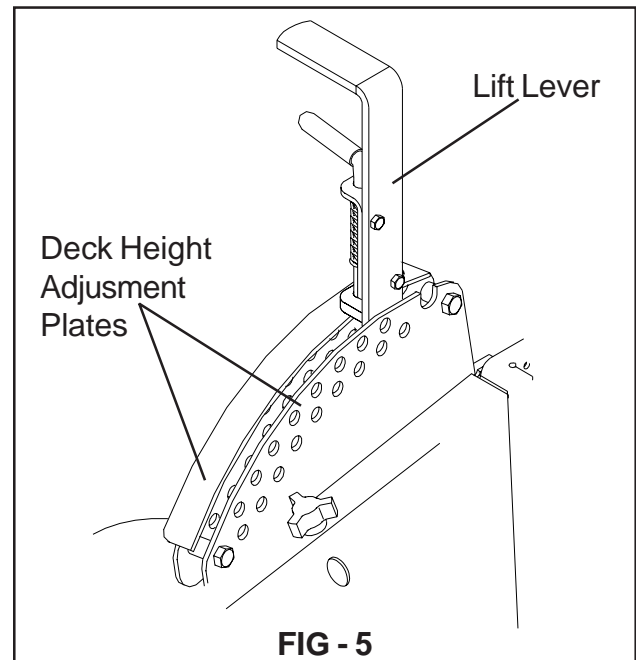

## **Reverse Spring Detent Adjustment**

Stop engine and remove key.

Pull the motion control lever back to the reverse position and release the lever. When the lever stops it should be in line with the neutral slot, so you can move the lever into neutral slot without hitting the side of the console frame.

If adjustment is required put the seat in the rear most position on the slide, tilt the seat forward, remove the seat rod from seat frame and fold seat over forward onto the frame.

On the back of the console where the spring is fastened, loosen the 3/8" nut and bolt enough to allow the bolt to slide in the slot. FIG - 7

Rotate the motion control lever out into the neutral slot. While the lever is swung out into the neutral slot pull it against the back edge of the neutral slot. Holding the lever adjust the spring by sliding the bolt in the slot to remove all the slop and retighten the bolt.

Check your adjustment by repeating the second step in this process.

If no more adjustment is needed reassemble the seat rod to the seat frame.

## **Park Brake Adjustment**

When park brake is in the engaged position the distance between the trunion and the bolt head at the rear of the assembly should measure 1/4" and the spring should measure 1.5" +/- 1/8". To adjust the 1/4" gap between the trunion and the bolt head loosen the nut against the yoke then turn the bolt head the proper direction to achieve the proper gap. To adjust the length of the spring turn the nut against the spring the proper direction to lengthen or shorten the spring. This adjustment is the same for both sides. FIG - 8

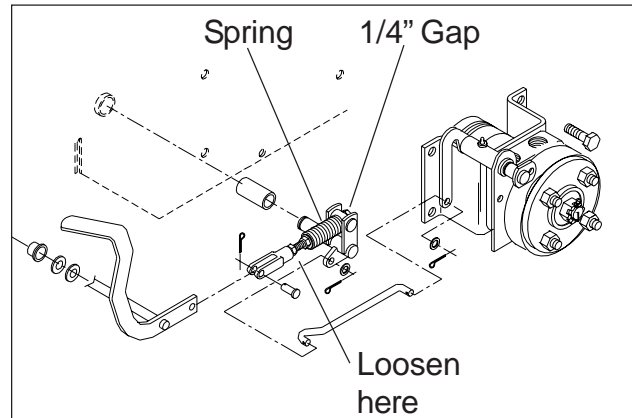

**FIG - 8**



## **Motion Control Linkage Adjustment**

This adjustment must be made with the rear wheels rotating. Raise the rear of the machine and block it up so the wheels are free to rotate. **CAUTION: Keep hands, feet and clothing away from rotating tires.**

Tilt seat forward and remove the seat rod so the seat may rotate forward onto the frame.

Place a 2x4 board between the foot plate and the center of the seat to engage the seat safety switch.

Loosen the nuts directly behind each ball joint on both rods that connect the pump arm to the motion control assemblies. FIG - 9

Start the engine. The park brake must be engaged and the motion control levers in the neutral slots to start the engine. Run the engine approximately half throttle

Release park brake to allow the wheels to rotate.

Begin with either side and put the motion control lever into the neutral position. Adjust the motion control linkage by rotating the double nuts in the proper direction until the wheel stops rotating. FIG - 9 Move the motion control lever forward then into the neutral position and place it into the neutral slot. The wheel must be stopped completely at this point. Now do the same in reverse and release the lever. The lever should return to neutral on its own. If not see reverse spring detent adjustment.

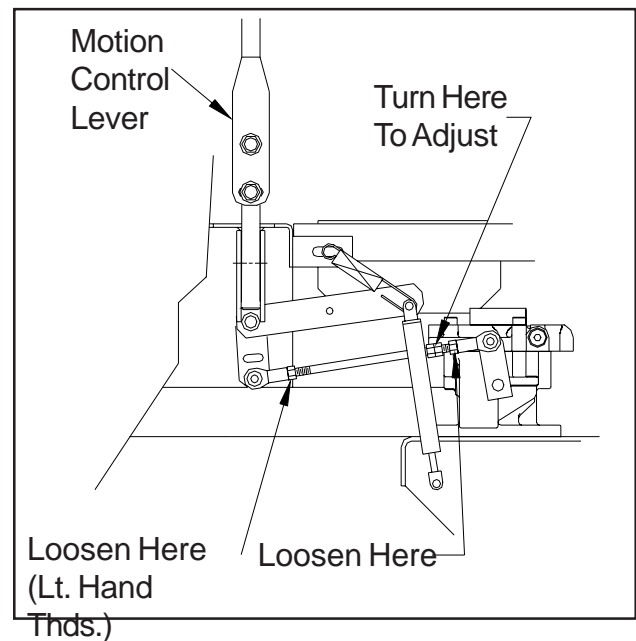

**FIG - 9**

For Husqvarna Parts Call 606-678-9623 or 606-561-4983

