

For Husqvarna Parts Call 606-678-9623 or 606-561-4983



Electrolux

H O M E P R O D U C T S



2002 SERVICE UPDATE INFORMATION

www.mymowerparts.com

NOTES

TABLE OF CONTENTS

Steering changes for Lawn Tractors	4
Fuel Tanks / Seat improvements	6
Brake Adjustments	7
DLT Transmission installation / Freewheel Rod/ Control Linkage	8
DLT reverse Pedal / LT Belt Guide / GT Assist Spring change	9
Electrical Components Improvements	10
Electrical Components Quick Reference	11
Tractor Electrical Troubleshooting Basics	12
Tiller Improvements	17
48" Mower Baffle	18
48" Deflector / Blade Bolt Torque / Nose Roller Kit	19
Changes to the Two Bin Bagger	20
EZ Walk Mowers - Drive Cable Adjustment	21
EZ Walk Drive Pinion	22
EZ Walk Drive Pinion - Gearbox - Blade Adapter	23
EZ Walk Drive Cable Replacement	24
EZ Walk Drive Belt Replacement	26
HONDA Blade Brake Clutch	27
Changes to: Electric Start - Grass Catcher - Drive Wheels	28
Changes to: High Wheel Trimmers - Front Gear Drive Mowers	29
Blade List	30

NEW LAWN TRACTOR STEERING

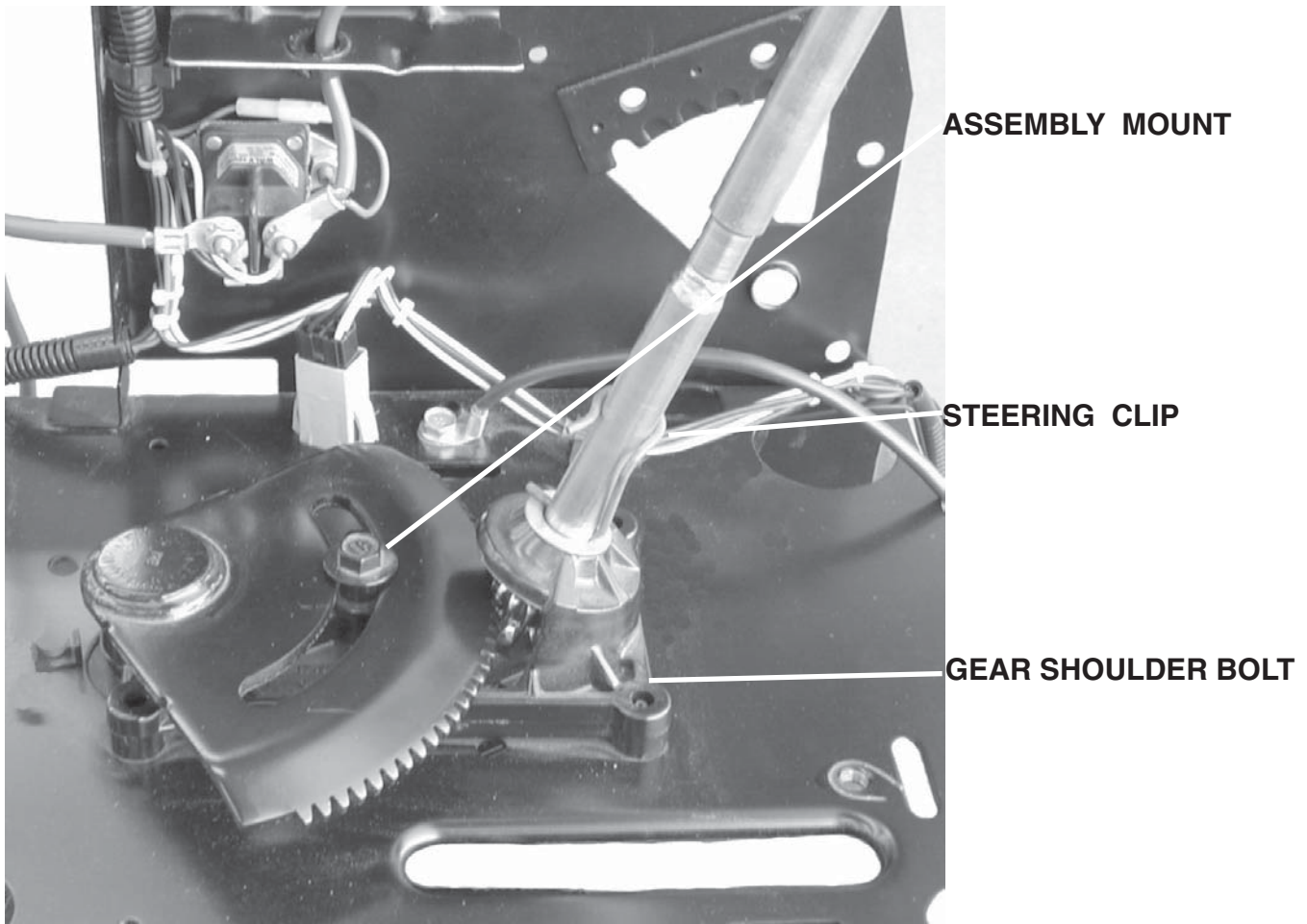

A new steering system was phased in during 2001 on lawn tractors. The new steering system is smoother and requires less effort to turn the steering wheel. The assembly mount is held by four self tapping screws from the underside. A washer is placed on the steering shaft and is retained by the steering clip.

NOTE: The new steering cannot be used to replace the old steering system because the chassis are made differently.

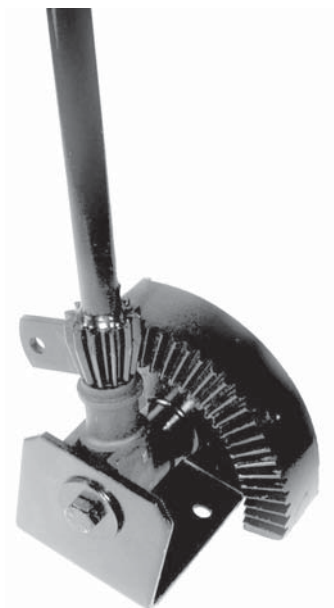

OLD STEERING ASSEMBLY

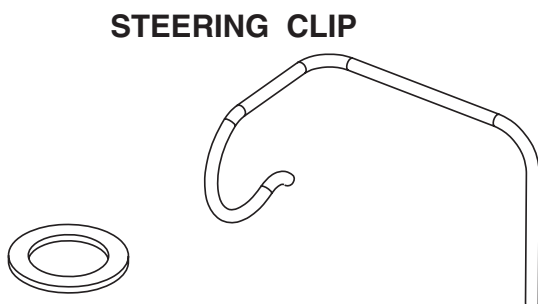

NEW LAWN TRACTOR STEERING

NEW STEERING

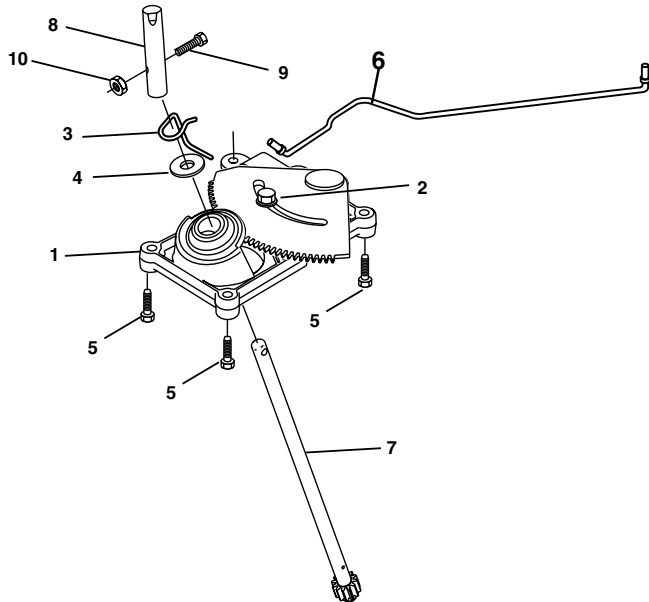

OLD STEERING

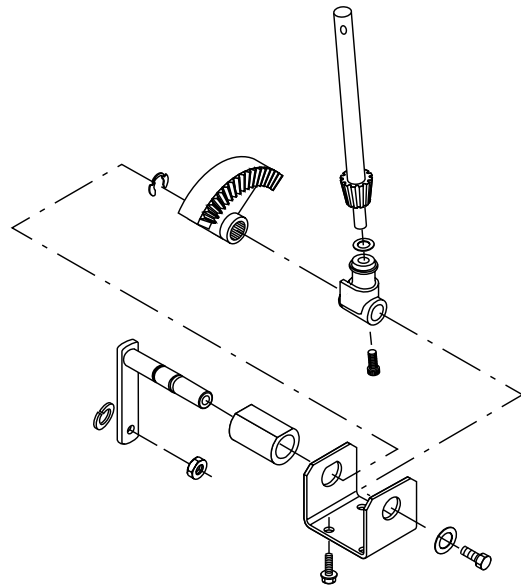

Replaces this Steering System on Lawn Tractors

PARTS FOR NEW LAWN TRACTOR STEERING

Key	Part Number	Description	Notes
1	175146	ASY - MOUNT - complete	Requires 175118
2	175118	BOLT-SHOULDER-GEAR	NOT included with 175146
3	175553	CLIP, Steering - Spring - 3/4"	
4	121749X	WASHER .781ID X 1.0OD X 16GA	
5	17060612	SCREW, 3/8 -16 X 3/4" Self Tapping	
5	17060616	SCREW, 3/8 -16 X 1.0" Self Tapping	Also mounts drive belt keeper
DRAGLINKS used with new LT Steering			
6	175121	DRAGLINK - 15" FRONT WHEEL .LT.2001	
6	175122	DRAGLINK - 16" FRONT WHEEL .LT.2001	
MY2001 Steering Parts used with LT HOOD			
7	177876	Shaft-Assembly - 17.8" LENGTH	- Thru-hole dia .331
8	153720	EXTENSION-STEERING, uses bolt	- 3/8-16 threaded hole
9	74780520	5/16-18 X 1.25" Bolt GR 8	
10	73800500	5/16-18 HEX LOCKNUT	
MY2002 Steering Parts used with LT HOOD			
7	180641	Shaft-Assembly - 17.8" LENGTH	- End with dia .265 thru hole
8	180640	EXTENSION-STEERING, uses locknut	- Double D with 1/2-20 Threaded End
9	71130420	1/4-28 X 1.25" Bolt - Grade 8	
10	73540400	1/4-28 NUT Crown Lock	
Steering Parts used with STEALTH / DLT / LARGE HOOD			
7	177883	Shaft Steering - 23.4" LENGTH	- Double D with 1/2-20 Threaded End

LARGER FUEL TANKS ON DELUXE MODELS



The Operator can view the fuel level in rear tank through the fender for 2002. Garden Tractors will have 5 gallon tanks. DLT models will have 4 gallon rear tanks.

NEW SEAT MOUNTING

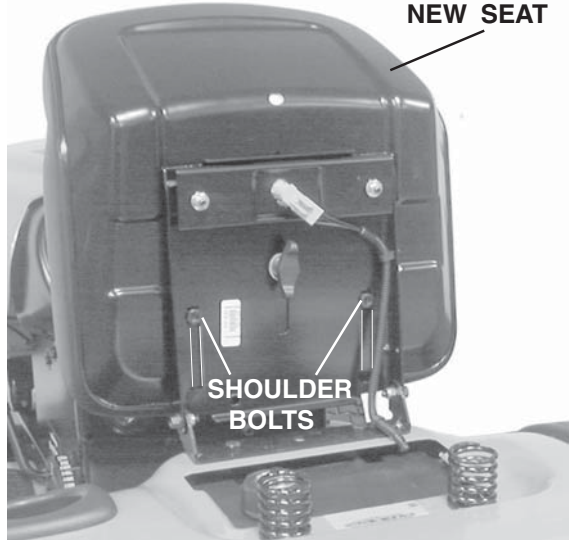
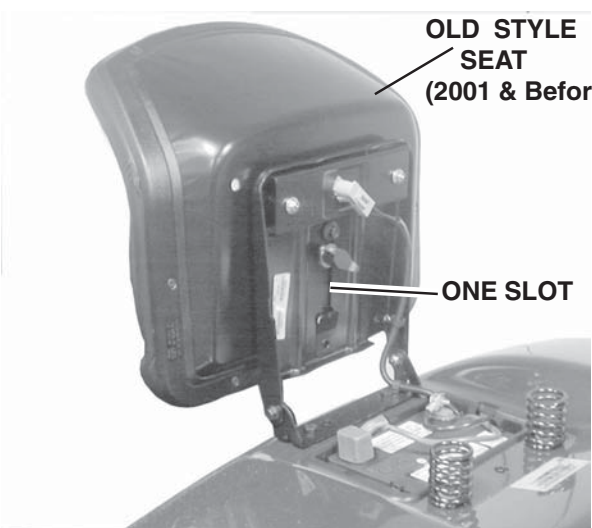

There will be a transition to a new seat system this year. The new seat will have two shoulder bolts that will slide in two slots in a new wider seat pan. Because of the wider seat pan, the seat pivot bracket will be wider. The old seat pan had one slot and two tracks allowing the seat to slide forward and backward.

TRACTOR BRAKE ADJUSTMENTS

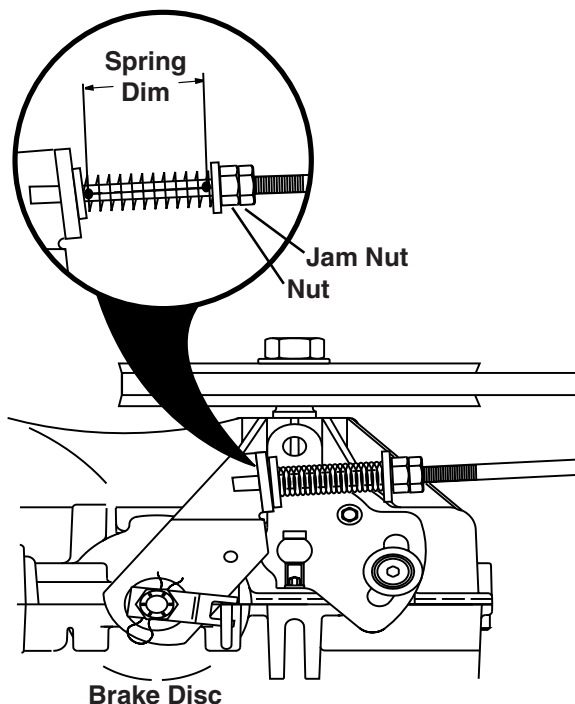

Engage Parking Brake and check the Brake Spring Dimension.

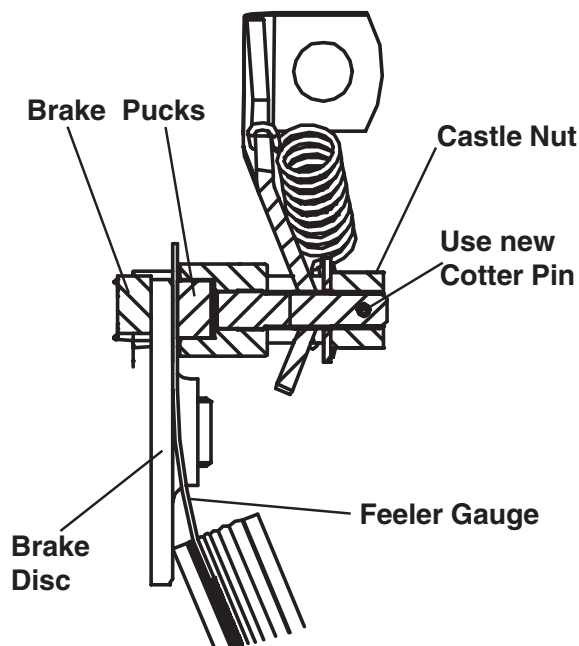

Use feeler gauge to set Puck Clearance at recommended dimension.

BRAKE ADJUSTMENT DIMENSIONS			
TRANSMISSION		SPRING DIMENSION	PUCK CLEARANCE
Peerless MST	LT	1 1/2 "	.015 "
DANA 4360	LT	1 1/2 "	.020 "
Hydro Gear 0510 PCA	LT	1 3/4 "	.015 "
Hydro Gear 0510 LCA	LT	1 9/16 "	.015 "
Hydro Gear 0510 CRD	LT	1 11/16 "	.015 "
Hydro Gear 0500/0650/0750 *	LT	1 9/16 "	.020 "
EHP XHD Hi-Lo Range	GT	1 3/4 "	.015 "
Hydro Gear 3010L	GT	1 1/2 "	.020 "
Hydro Gear 3000 / 3500	GT	Not Adjust	.015 "

PCA = Pedal Controlled Automatic LCA = Lever Controlled Automatic

NOTE: Any time you do anything with the brake, the brake must be tested. The tractor must stop within six (6) feet on a level paved surface from the fastest speed. Test the tractor to hold itself on a 15 degree slope with the parking brake. If the brake does not pass tests, the brake puck clearance must be adjusted tighter. There is a slope guide in the tractor owners manuals.

NOTE: If excessive wear is found on the brake disc or the brake pucks, these parts should be replaced before adjustments are made. Use a new cotter pin to lock the castle nut after adjustment.* HG 0500-0650-0750 insert the feeler gauge between the brake rotor and stator rings from underneath. Be sure to fully insert the gauge through the lower and then the upper part of the rotor and stator rings.

DLT PEDAL AUTOMATIC REVERSE COMPLAINTS

DLT tractors with Pedal Control Automatic may have complaints of slow reverse or no reverse if the correct installation procedure is not used.

Tighten fasteners in this sequence:

- Loosely assemble all screws or bolts and nuts that hold transaxle.
- Tighten the screws labeled 1 that hold the transaxle to the Torque Strap.
- Tighten the screws labeled 2 that hold the Torque Strap to the Chasis.
- Tighten the nuts and bolts labeled 3 that hold the axle supports to the rear mounting brackets.

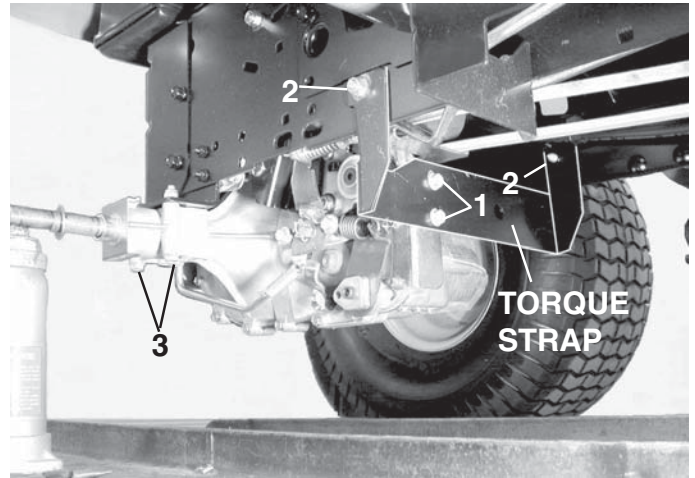

NOTE: If this procedure does not increase the reverse speed. Use a straight edge to check the Torque Strap. If there is a severe bow toward the rear, the transaxle is located too far rearward.

DLT FREEWHEEL CONTROL ROD

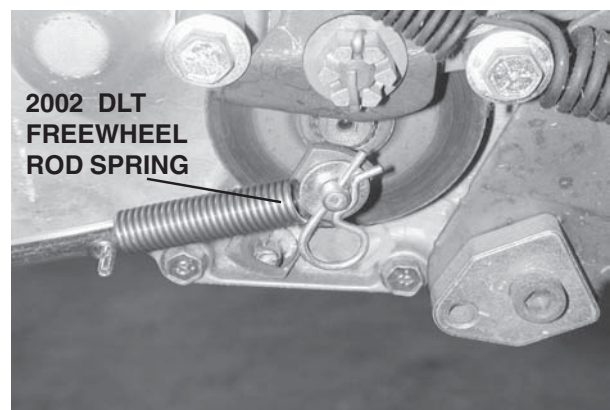
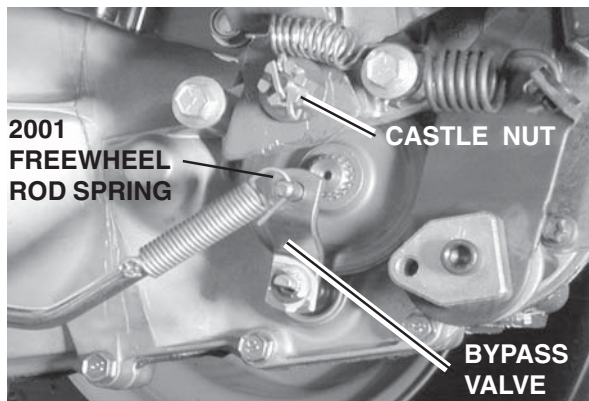

The attachment of the spring on the Freewheel Control Rod to the Bypass Valve has been improved on DLT tractors. The end of the spring is formed differently and a 179422 washer and 4497H retainer spring now retain it to the Bypass Valve.

DLT AUTOMATIC PEDAL LINKAGE

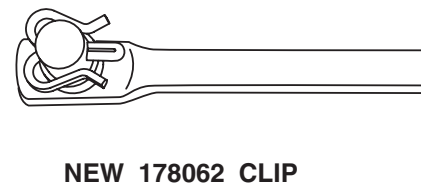
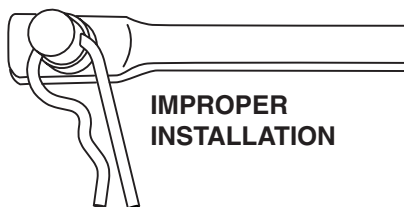

The linkage going from the Foot Pedals to the Automatic Transaxle control arm was retained with 4497H Retainer Springs. If improperly installed, the 4497H can keep the linkage from the full range of movement needed. The tractor may not go as fast in forward or reverse as it can. In 2002 a change is made to a 178062 Clip so it cannot be installed improperly.

DLT REVERSE PEDAL IMPROVEMENT

The 179433 Reverse Pedal now comes with the Pedal, Pedal Cover, and the Screw installed. One shoulder bolt under the footpad can be removed and used to install a new reverse pedal assembly.

REVERSE
PEDAL

SHOULDER
BOLT

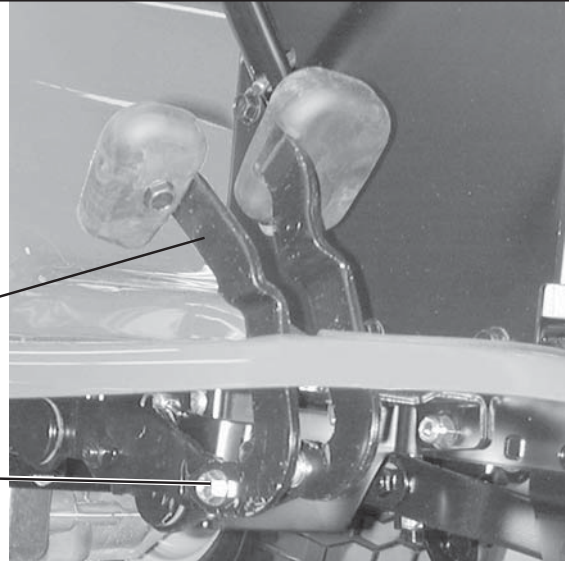

LT BELT GUIDE CHANGES

Changes have been made to improve the belt guide on the 6 speed lawn tractor transaxles. The guide is now closer to the pulley to better retain the belt and improve belt disengagement characteristics. To identify the belt guides, the loop for the screw that retains the belt guide is in the reverse direction on the 178394. The previous number was 173898.

LOOP ON PREVIOUS
173898 BELT GUIDE

178394 BELT GUIDE

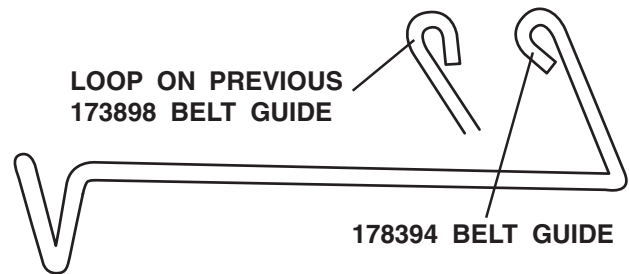

GARDEN TRACTOR LIFT ASSIST SPRING CHANGE

The Lift Assist Spring Assembly on Garden Tractors will now be part of the Sleeve Hitch Kit, beginning in 2002. A slot has been added to the bracket on the Lift Shaft. The end of the spring is hooked into the slot. A bolt, nut, and washer are then installed to hold the assist spring in the proper position. The bracket at the other end of the spring will need to be attached to the chasis. Complete instructions will be included in the Sleeve Hitch Kit.

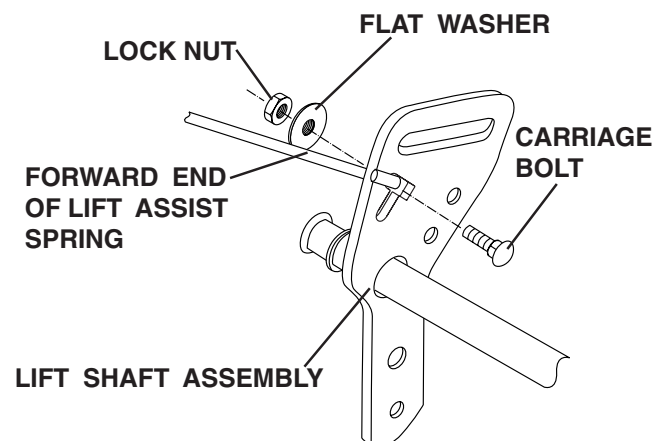

ELECTRICAL COMPONENT IMPROVEMENTS FOR 2002

A lock tab is added to snap in Interlock Switches for 2002. The new switch will work for the switches without a tab.

176137	SWITCH	NO-NO	BLACK / GRAY
176138	SWITCH	NO-NC	GRAY



A new interlock switch at the footpedal will be used with tractors equipped with POWERLINK. It is part # 181884. This is a NO-NO-NO switch. The additional set of contacts are needed so that POWERLINK cannot function unless the Parking Brake is engaged.

SWITCH CONNECTOR

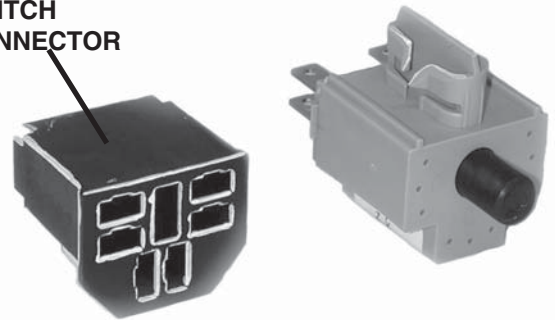

The reset switch used with POWERLINK is a part # 110712X. This switch was used in the past as a tractor headlight switch.



There will be a new Battery Box 176689 under the seat on lawn tractors. Where this battery box is used, a 180499 Battery Terminal Cover must be installed where the red battery cable attaches to the positive battery terminal.

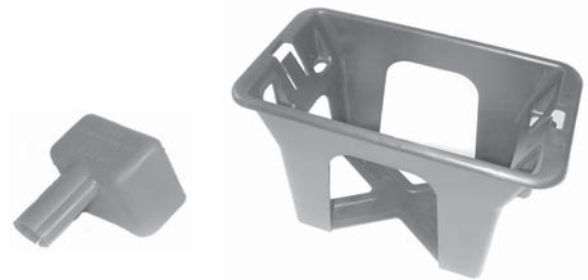

Snap in retainers will be attached to the electrical harness to give more places where the harness is held to the chasis.



Ignition Switch 163968 --> 175566 7 terminals / DELTA (plastic) snap - in	Ignition Key (delta) 140401 generic cover	Halogen Headlight Assy 175448 DLT tractors only (2001 & newer product)	Interlock Switch 161343--> 176137 NO / NO - snap-in Black / Gray	Interlock Switch 109553X NO / NC screws Gray	Ammeter (15 Amp) 122822X
Ignition Switch 5 terminals / DELTA (plastic) 175567 - No Headlights snap - in	Ignition Key (delta) 140403 Craftsman cover	Headlight Socket (small) 175242 two terminals - (bulb 7152J) (2001 & newer)	Interlock Switch 153664--> 176138 NO / NC - snap-in Gray	Interlock Switch 109869X NC / screws - Gray	Ammeter (DLT-DGT) 175548 stud with nuts
Ignition Switch 158913 - 5 terminals / Indak (diecast) Gray Plastic Back	Ignition Key (indak) 109310X Craftsman cover	Headlight Socket (large) 148709 two terminals - (bulb 7152J)2001 & before	Interlock Switch 181884 NO-NO-NO -Gray- Snap-in POWERLINK only	Interlock Switch 104445X NO / screws	Jumper Wire 140844 - (ammeter)
Ignition Switch 140301 - 7 terminals / Indak (diecast) terminals in pyramid	Ignition Key (indak) 122147X generic cover	Headlight Socket 163996 Stealth Hood only (bulb 7152J)	Interlock Switch 166299 for CRD NO / screws / spring tension	Interlock Switch 180379 for CRD NO - Snap-in - Black -	Switch - POWERLINK 110712X
Ignition Switch 2683R 5 terminals / Indak (diecast) Battery Ignition / ONAN	Ignition Key (delta) 175447 RED DLT Cover	Diagnostic Jumper Kit 150834 (diagnostic tool)	PTO Switch (7 terminals) 154963 - Red Knob 169417 - Black Knob retainer REQUIRED	Seat Switch 160784 - NO - Olive Green	Tachometer 181833 DLT - DGT only <i>Round (new 2002)</i>
Ignition Switch std365402 / 4406R 5 terminals / Indak (diecast) White plastic back	NUT, Ign Sw, (Delta) 145774 (Plastic)	Terminal Connector Kit 148691 (parts to repair harness)	140405 - Retainer, Switch will NOT work if 8 terminals m.y. 2000 and before	Seat Switch 121305X NC - Gray	Hourmeter (DLT-DGT) 175549 analog spade connectors
Ignition Switch std 365401 screws/ Indak /diecast (Delco Starter Generator)	NUT, Ign Sw, (Indak) 124211X (Plastic)		PTO Switch (8 terminals) 174651 - Red Knob 174652 - Black Knob 174653 - Yellow Knob	Relay 109748X	177501 digital 4 pin connector
Battery Cable Terminal 148698	COVER, Ign Sw Nut 141226 (Rubber)		140405 - Retainer, Switch will work for 7 terminals new for 2001	Holder, Relay 172989	Hourmeter (rectangular) 169635
	Solenoid 171141	20 AMP Fuse 175158 (Yellow)		Battery Box - LT 176689 <i>Use 180449 Cover</i>	Hourmeter Bracket 169639
	Solenoid Kit 146154	30 AMP Fuse 108824X (Green)			Wire Loop 141940 - (hourmeter)
					Cover, Terminal(Red) 131563 - Solenoid 180449 - Battery

TRACTOR ELECTRICAL TROUBLESHOOTING BASICS

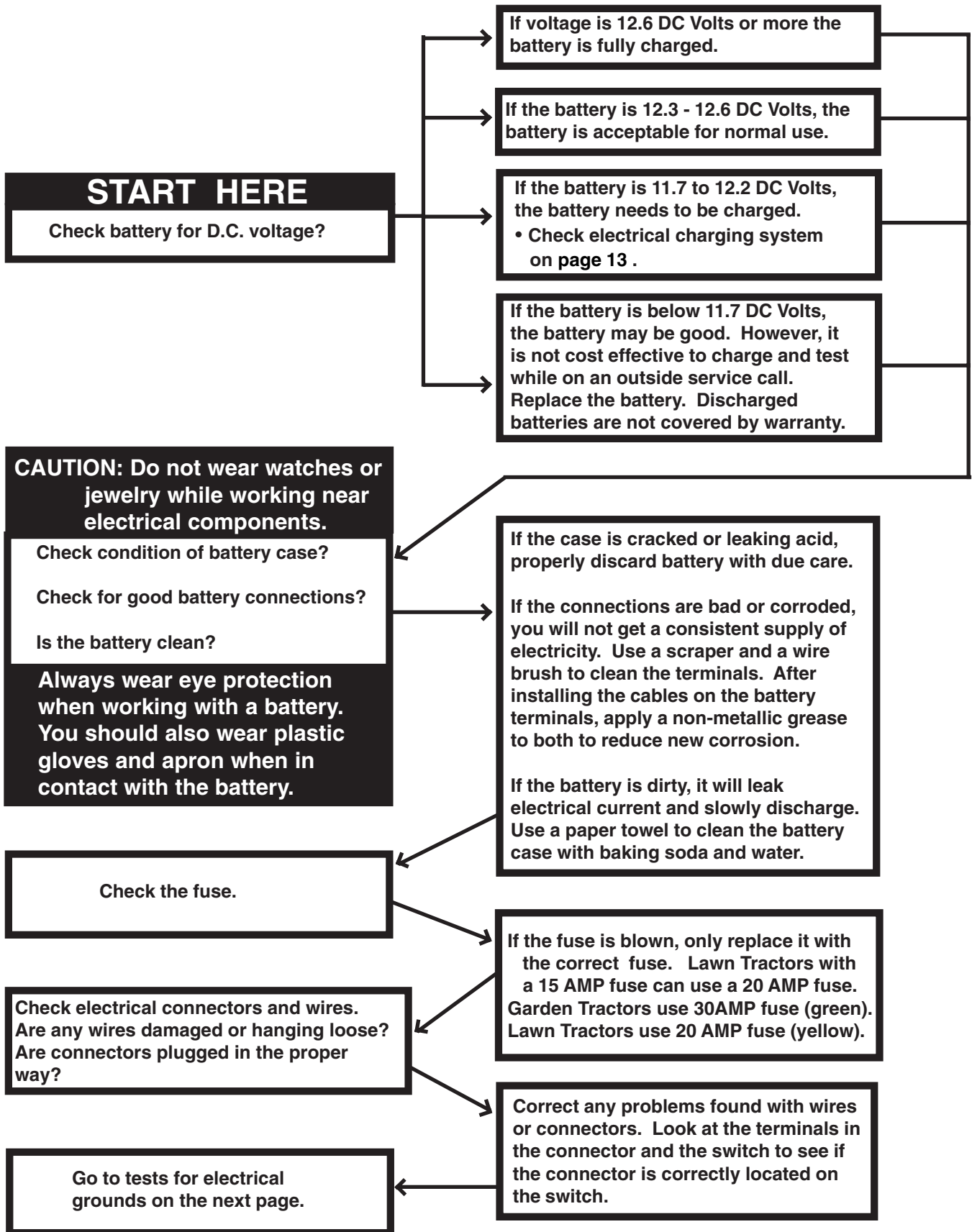

TRACTOR ELECTRICAL TROUBLESHOOTING BASICS

START HERE

Electrical Grounds are necessary to make a complete electrical path so a circuit can function. Use an electrical meter for this check.

A reading of more than 0.5 OHMS indicates a poor ground that resists the passage of electricity. You will need to improve the connections between parts to get the resistance to electrical passage below 0.5 OHMS. Do this by scraping where electrical contact is made between parts, until the finish is bright metallic. **EXAMPLE:** Where the eyelet for the black battery cable meets the chassis.

Move the selector on your meter to the OHMS or R X 1 position. Connect the leads to the meter for OHMS.

Hold one meter probe to the negative battery post.

Hold the other meter probe to a clean metallic surface on the item that is not functioning.

If you get a reading of 0.5 OHMS or less grounds are good, you can stop.

If you get a reading greater than 0.5 OHMS, you will need to track down the poor connection. Start at the battery cable and check components going toward the item that is not working. When you find a place where the resistance increases, you have a place where an electrical connection must be improved.

NOTE: There are two starwashers used to cut through the paint to make a good ground. One is at one of the screws that holds the engine to the chassis. The other is where the black battery cable is held the chassis.

START HERE

Check electrical charging system.

Move selector on meter to DC Volts or scale for 12 DCV. Place leads in positions for Voltage.

With engine off check the battery voltage.

Note the DC Voltage reading.

Start engine, raise engine to fastest RPM for two full minutes. Check voltage at battery.

If the reading is above 12.8 DC Volts, the charging system is working. Discontinue charging tests.

If the tractor has relays, test the relays on page 16. If any of the relays test bad, replace the relay and test the charging system again. In some wire harnesses, a relay makes an electrical connection between the engine charging system and the battery.

If the DC Voltage reading is the same as the reading noted with the engine off, the charging system is not working, or is not connected to the battery. Refer to electrical section of engine manufacturer's manual to further diagnose charging system.

TRACTOR ELECTRICAL TROUBLESHOOTING BASICS

START HERE

Check starting circuit to SOLENOID

The starting circuit is identified by a white wire. Remove from the solenoid the connector for the white wire. Place a meter probe into the white wire connector. Move the meter selector to DC Volts or range that includes 12VDC. Check to see that meter probe leads are installed in correct positions. Attach other meter probe to a good ground.

Sit on tractor seat. Place mower control in disengaged position and hold footpedal to lowest position. Watch meter reading while turning ignition switch to 'Start' position.

If the meter shows 0.0 DCV in the 'Start' position, there is a problem with wiring, connections, ignition switch, interlock switches, or PTO switch in this circuit. It will be necessary to evaluate each item in the circuit until the item causing the problem is found. There is a 150834 diagnostic jumper kit that will allow the switches to be evaluated quickly.

If meter shows 0.0 DCV with ignition switch in 'Off' position and about 12 DCV in 'Start' position, the circuit is functioning properly. The wiring, connections, ignition switch, interlock switches, or PTO switch are all good.

START HERE

Check 'ground' for solenoid.

The ground wires are identified by a black wire. Remove from the solenoid the connector for the black wire. Place a meter probe into the black wire connector. Move the meter selector to DC OHMS or range R x 1. Check to see that meter probe leads are installed in correct positions. Attach other meter probe to the negative (-) post of the battery.

If the resistance reading is less than 0.5 OHMS, the solenoid ground is good. Test solenoid on page 15.

If the resistance reading is more than 0.5 OHMS, one reason the solenoid is not working is a bad ground.

- Correct ground problem.
- Connect everything and try solenoid.

There is a 148691 Terminal Connector Kit available. It includes many of the connectors, terminals, and other parts used in the tractor wire harness. The kit includes butt splice connectors for repairing wires and 30 AMP fuses.

There is a Diagnostic Jumper Kit 150834 available. It includes jumper wires, a heavy duty jumper cable, a circuit breaker, and an instruction sheet. The circuit breaker can be plugged into the fuse holder. This eliminates blown fuses while looking for short circuits. The jumper wires are used to determine which switch is not functioning.

TRACTOR ELECTRICAL TROUBLESHOOTING BASICS

DIAGNOSIS OF STARTER SOLENOIDS

- Remove the red cable from the engine starter motor before testing.
- Place digital meter selector on D.C. Voltage scale that includes 13 Volts.

Step # 1.

1. Place meter probes on battery terminals. If the reading is 12.2 VDC or more, proceed to the next step. If the reading is below 12.2 VDC, charge or replace the battery with one that has at least 12.2 V DC.

Step # 2.

1. Connect negative (black) meter lead to the battery negative (-) terminal.
2. Connect the positive (red) meter lead to the 'hot' terminal of the solenoid.
3. Note the voltage reading.

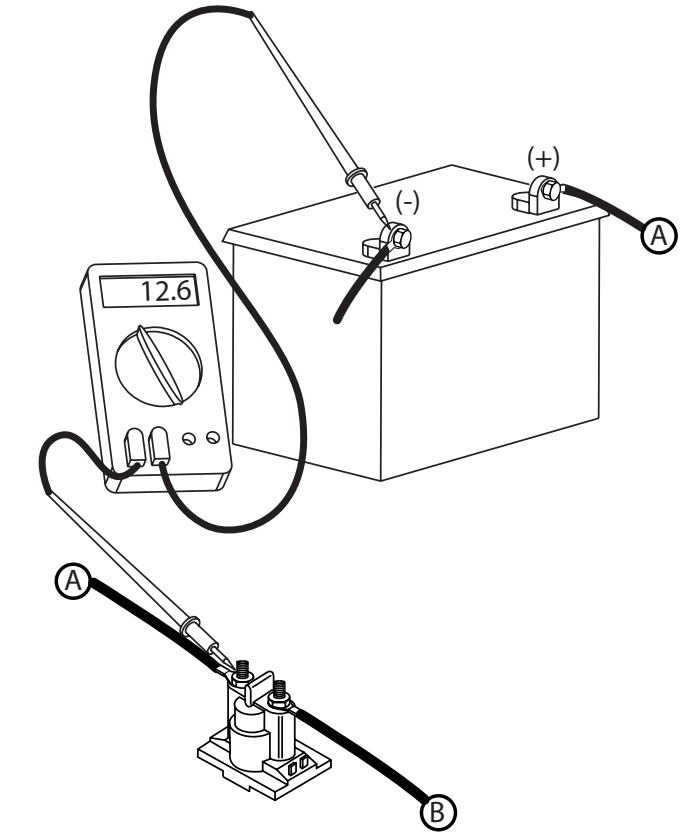

Step # 3.

1. Keep the meter selector in the same position and the negative meter lead connected to the battery negative terminal.
2. Connect the positive (red) meter lead to the end of the cable normally connected to the starter motor.
3. Engage the parking brake and turn the ignition switch to the "START" position.
4. Note the voltage reading.
5. If the voltage drop is more than 0.50 VDC between the two noted readings, the solenoid or the starter cable is suspect. Replace the solenoid.
6. Re-install the red cable to the starter motor. If the solenoid checks acceptable and the starter does not crank, check for clean tight battery connections and check the grounds for the battery and the engine.

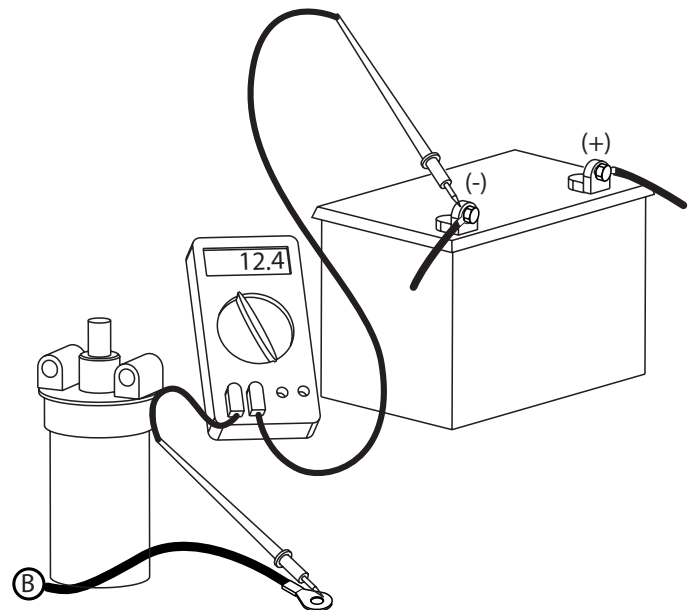

TRACTOR ELECTRICAL TROUBLESHOOTING BASICS

DIAGNOSIS OF ELECTRICAL RELAY 109748X

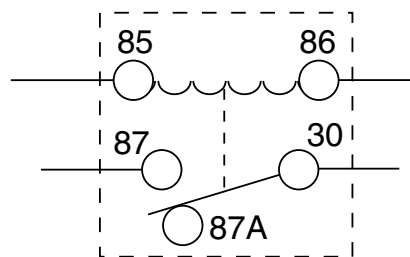
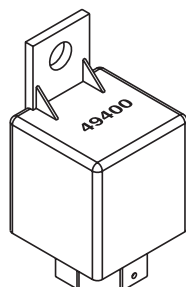

Remove Relay from harness connector before testing.

Test # 1, Coil Resistance

1. Set meter to Ohm's scale
2. Attach leads to Relay terminals 85 and 86.
3. There are two relays: if the number 49400 is on the relay it is 1998 or newer and should read **68-82 Ohms**. Relays with a Hella logo were made before 1998 and should read **80-90 Ohms**.

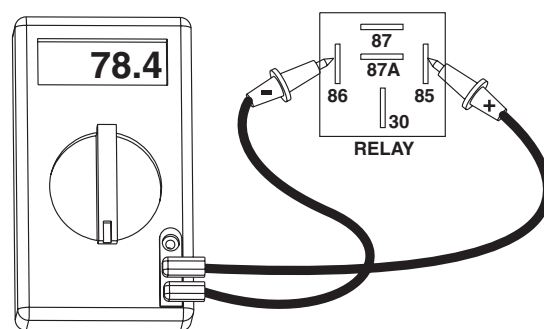

Test # 2, Continuity when energized

1. Attach a 12 DC volt power source to Relay terminals 85 and 86.
2. Set meter to continuity test or Ohm's scale.
3. Check for continuity between Relay terminals 30 and 87; then 30 and 87a.
4. You should have continuity between terminals 30 and 87 only when the relay is energized. If you have continuity between 30 and 87a when energized, the relay is defective.

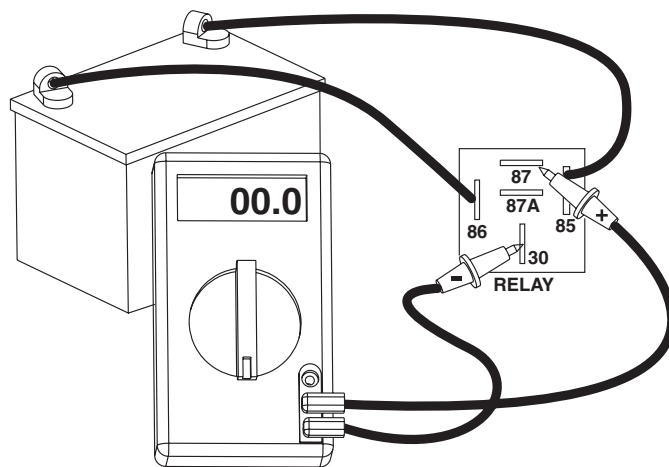

Test # 3, Continuity when NOT energized

1. Remove the power source from relay terminals 85 and 86.
2. Check for continuity between Relay terminals 30 and 87; then 30 and 87a.
3. You should have continuity between terminals 30 and 87a **only**.

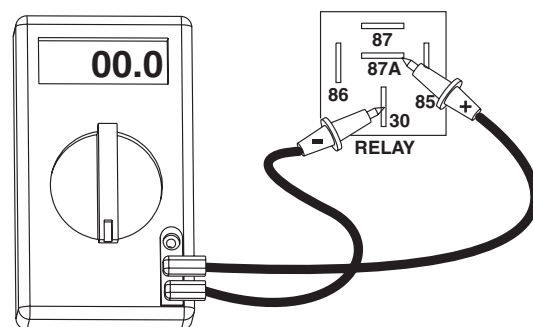

TILLER CHANGES FOR 2002

Front tine tillers with reverse will now have a cable that operates the reverse mechanism instead of a steel rod linkage. This will result in smoother more trouble free operation.

REVERSE IDLER
ARM ASSEMBLY

REVERSE CABLE

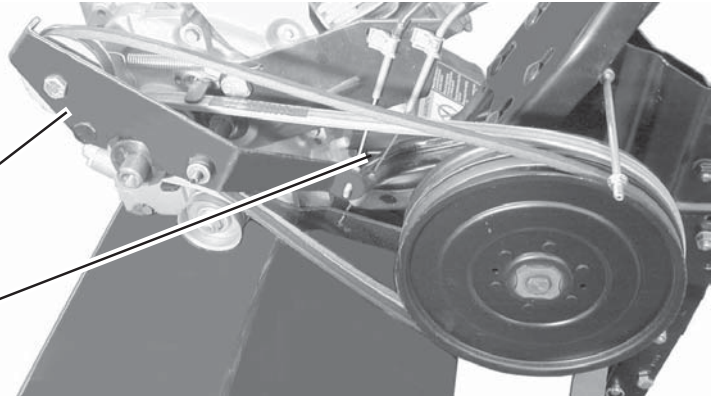

The Depth Stake Assembly will now be fastened to the pallet with two screws. In the past the depth stake was cradled in packaging materials. Customers sometimes lost the assembly when they threw out the carton packaging materials. The two bolts and nuts used to assemble the depth stake assembly to the tiller frame will be in the parts bag.

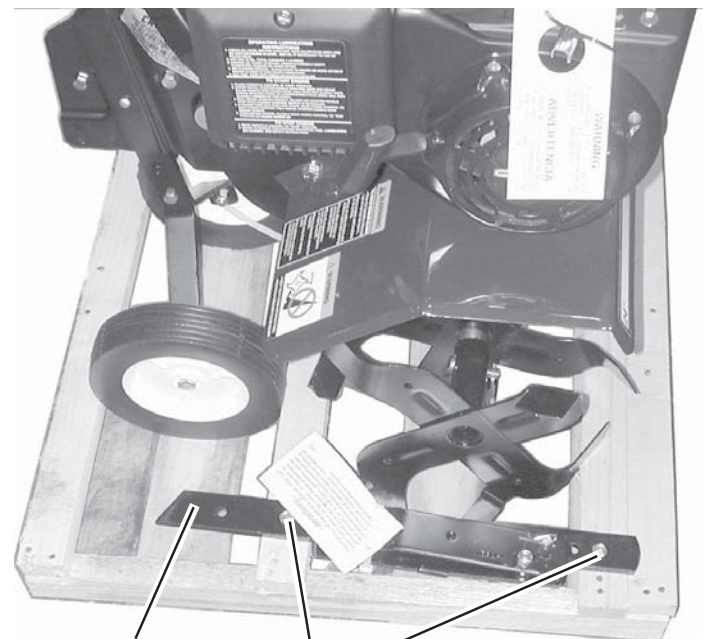

DEPTH STAKE
ASSEMBLY

SCREWS

Transmission cases for CRT and DRT tillers have been improved for 2002. There will now be a shoulder bolt to maintain the opening for the depth stake. This will keep the case opening wide enough so depth stake will easily move up and down.

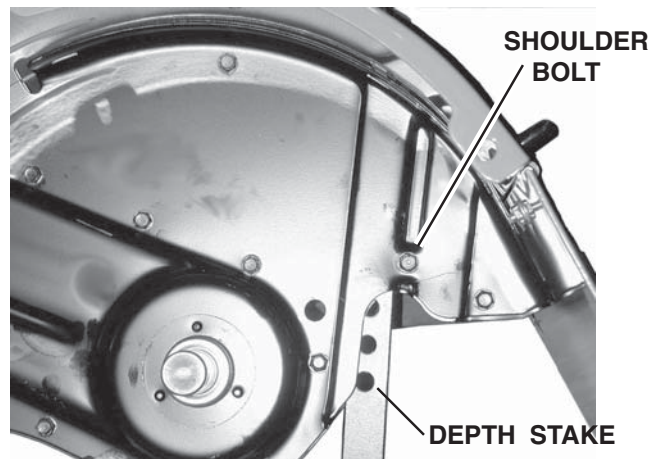

SHOULDER
BOLT

DEPTH STAKE

BAFFLE ADDED TO 48" MOWER

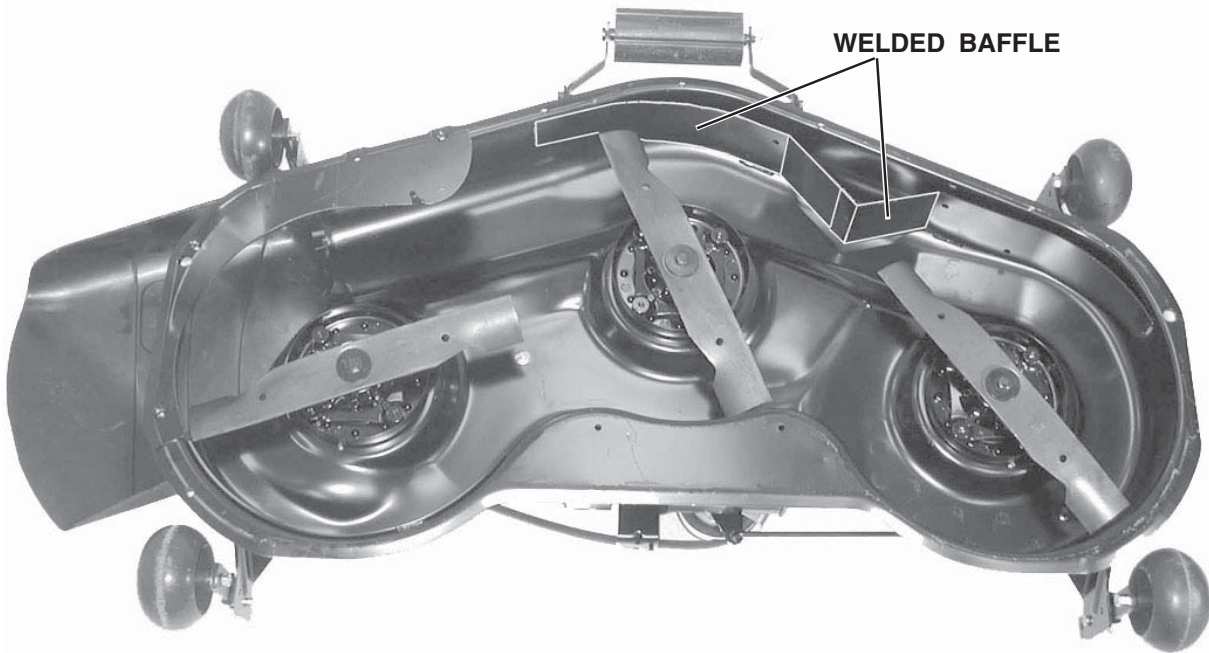

A welded baffle has been added to the front of the 48" mower housing to improve the grass blowout characteristics. This welded baffle will be found on production decks beginning in 2002. If there is a complaint about grass blowout on a deck without the welded baffle, use the 180487 Baffle Kit below.

48 INCH BAFFLE KIT NO. 180487

Use this kit for 2001 production 48" mowers where the customer complains of grass blowout from the front of the deck.

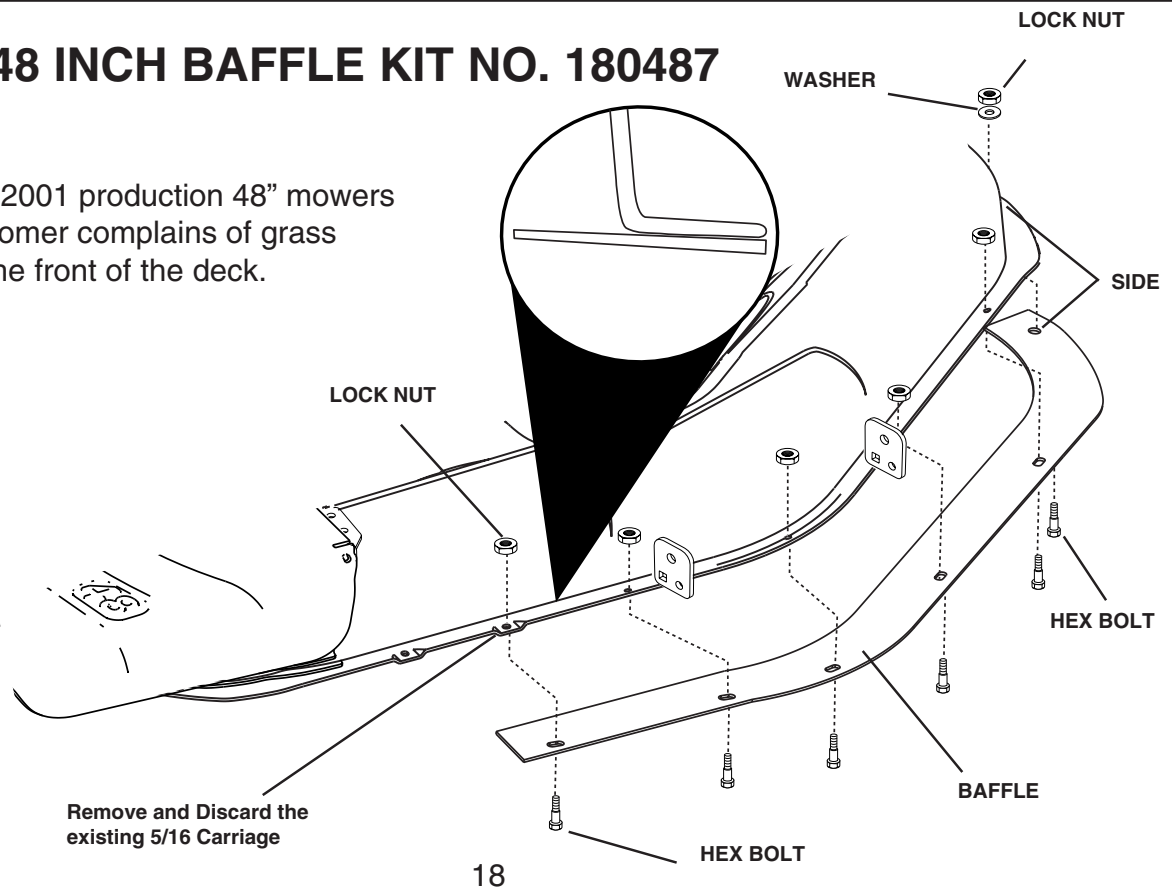

NOSE ROLLER DESIGN IMPROVED

The nose roller kits have been improved. There is now a rod between the brackets to support the nose roller. The brackets in the kit are now labeled 'A' and 'B' to help the customer to identify to which welded deck bracket each should be attached.

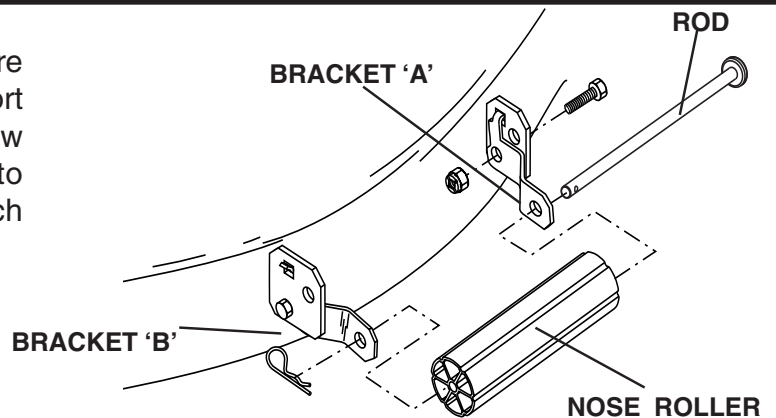

48" MOWER DEFLECTOR

The new 48" mower deck deflector is stiffer, heavier, and the hinge area has been reinforced. It is possible to identify the improved part if there are ribs above the '48' on the top of the deflector. The original deflector did not have ribs.

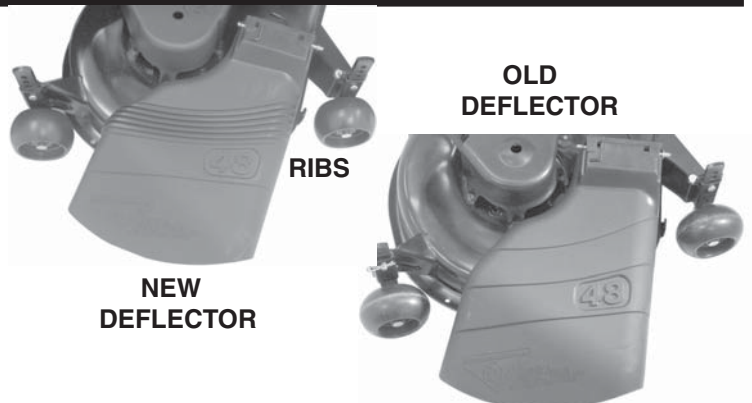

TRACTOR MOWER BLADE BOLT

Blade bolts should always be torqued to the proper range. For the 7/16 GR 8 Bolts (5/8" wrench) used on 48" mowers torque to 45-55 Foot Pounds. The factory bolt 174365 must be used because there must be a recessed area in the washer. For the 3/8 x 24 GR 8 Bolts (9/16" wrench) used on other tractor mowers torque to 30-40 Foot Pounds.

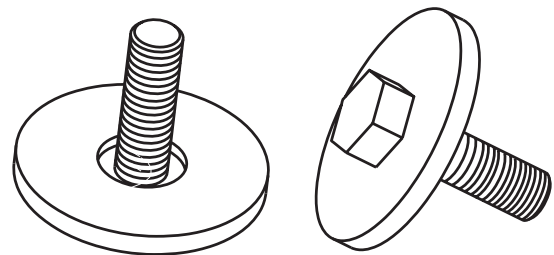

174365 BOLT ASSEMBLY
USED ON 48" MOWER

OTHER NOTES ON TRACTOR MOWERS

- New 180054 Blade for mulching and bagging on 48" mower will reduce grass blowout.
- New 180808 mower secondary belt on 48" deck will have increased life.
- The primary mower belt is changed to 148763 on the 50" deck for 2002. This is a larger belt cross section already in use on the 48" mower deck. The pulleys and idlers are different from those used on previous 50" decks in past years. If the wrong belt is used, the belt may see extreme wear in a short time.

IMPROVEMENTS FOR TWO BIN 38" & 42" BAGGERS

Improvements will make the installation of the two bin bagger easier than ever on Lawn Tractors with 38" and 42" mower decks. There will no longer be a pin to locate the post to the bracket as the two will be welded into a Support Assembly. The assembly is positioned with the bracket holes over four shoulder bolts in the drawbar. When the assembly slides down into place there is a Stop Bracket that locks into place. You will need to hold the Stop Bracket out of the Drawbar with a fingernail while removing the Support Assembly from the tractor. Extra shoulder bolts are shipped with baggers for older tractors that do not have shoulder bolts installed into the drawbar from the factory.

The Cover Assembly is positioned behind the tractor with the tubular bagger frame latched into place inside the cover. It is suggested that customers find another person to help install this assembly. There is a channel in the front and middle of the Cover Assembly that will slip over the top of the Post.

The grass containers used with all the baggers have been re-tooled. It will be easier to assemble the upper and lower container sections.

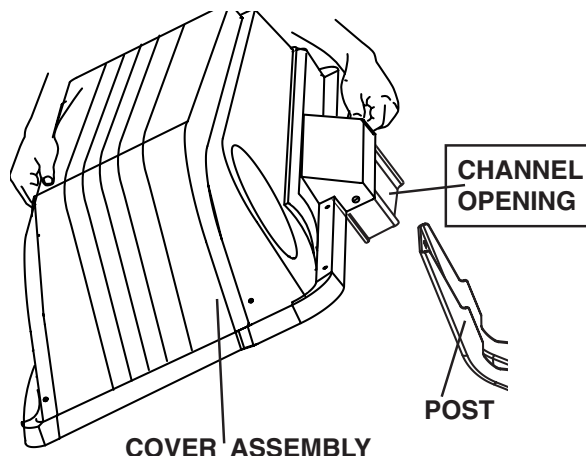
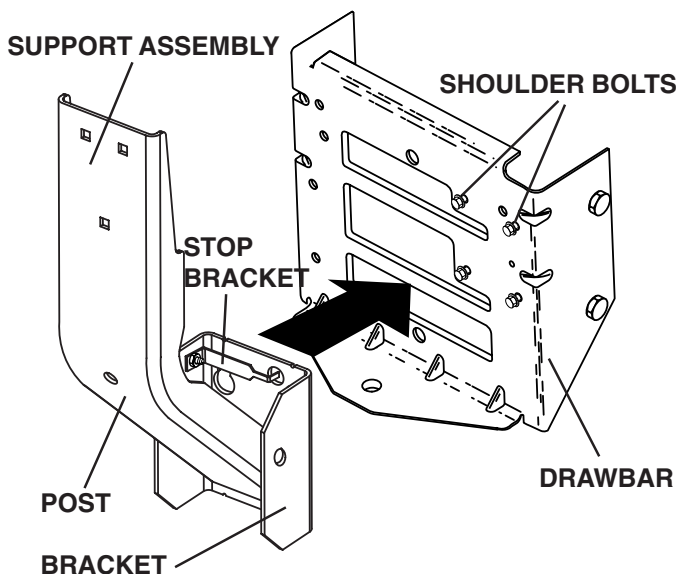

BAGGER END CAP KIT - Part Number 174695

FOR 2-BIN AND 3-BIN BAGGERS

2-BIN BAGGER

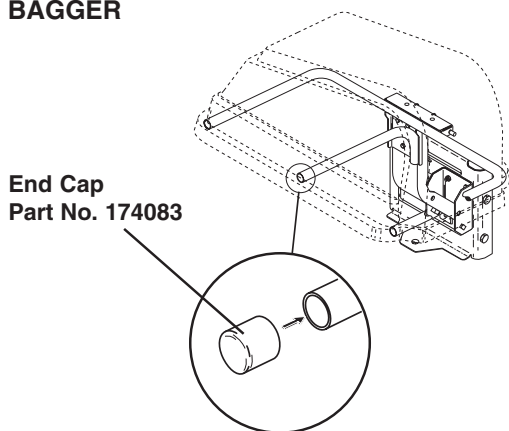

3-BIN BAGGER

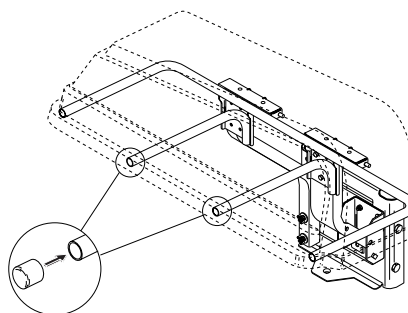

THIS KIT IS PROVIDED FOR BAGGERS WITH LOOSE LOCKING COVERS. FOR BETTER LOCKING OF THE BAGGER COVER DURING OPERATION, REPLACE THE END CAP ON THE CENTER SUPPORT TUBE WITH THE END CAP IN THIS KIT. TWO END CAPS ARE PROVIDED FOR THE 3-BIN BAGGER ATTACHMENT.

EZ WALK MOWERS - NEW FOR 2002



There is an EZ Walk drive system for both front drive and rear drive mowers for 2002. The EZ Walk system allows the customer to control the speed of the self propel system using a drive control lever in front of their right hand. When the drive control lever is released the mower stops. As the operator holds down the operator presence control bar and pulls the drive control lever, the mower self propel starts to drive. The tighter the operator pulls the drive control lever toward the handle, the faster the mower goes up to maximum speed. Both front drive and rear drive models have 21" cutting paths. The transmission access is the same as other rear drive and front drive models for the last few years. Some areas with which you will need to familiarize yourself are:

- Drive Cable Adjustment procedure
- Drive Cable Replacement procedure
- Drive pinion operation and servicing

DRIVE CABLE ADJUSTMENT



Over time, the drive control system may become "loose", resulting in a decrease in speed. There is a button on the underside of the drive control housing to increase tension on the drive cable. Proceed as follows:

1. With engine 'off', disconnect spark plug wire from spark plug.
2. Pull drive control lever ALL THE WAY BACK to the handle.
3. Push button on underside of drive control. While holding button in, return drive control lever to disengaged position, ALL THE WAY FORWARD.
NOTE: Do not ratchet the adjustment.
4. Release button.
5. Operate mower to test drive speed. If condition becomes worse after the above steps (forward speed has become slower), your system was not "loose". Repeating the above steps will return your unit to the proper adjustment and speed.
6. If condition fails to improve after the above steps (forward speed remains the same), your drive belt is worn and should be replaced.

E Z WALK - DRIVE PINION OPERATION

To access the Drive Pinion Assembly on the mower remove the drive wheel. The same Drive Pinions used on the front drive EZ Walk system are used on the rear drive EZ Walk system.

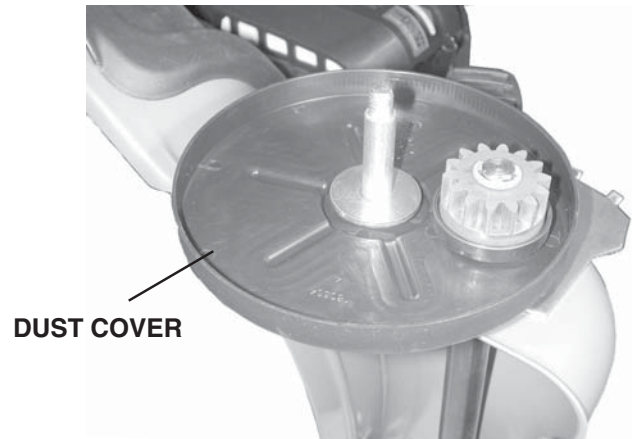

Only the complete Drive Pinion Assembly will be available from repair parts . The right side Drive Pinion Assembly is part number 176412 and is held with white plastic wrap. The left side Drive Pinion Assembly is part number 176413 and is held with clear plastic wrap. The plastic wrap is removed by pulling between the perforations after the pinion assembly is installed on the gearbox drive shaft.

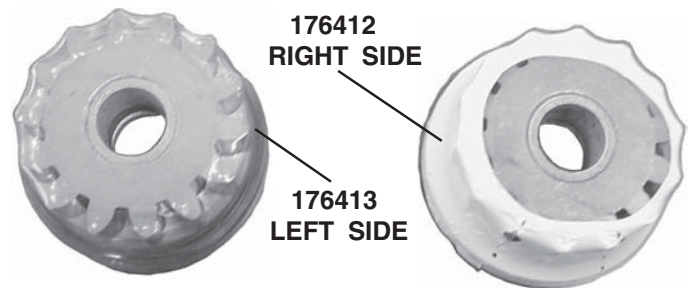

Only the Drive Retainer is different between the right and left side pinion assemblies. These are mirror image parts except for the letter to designate 'R' for right or 'L' for left. If you have a wheel that will not drive, first check to see if the drive belt is wet. If not, remove the pinion assemblies and check to see if the correct Drive Retainer is on that side.

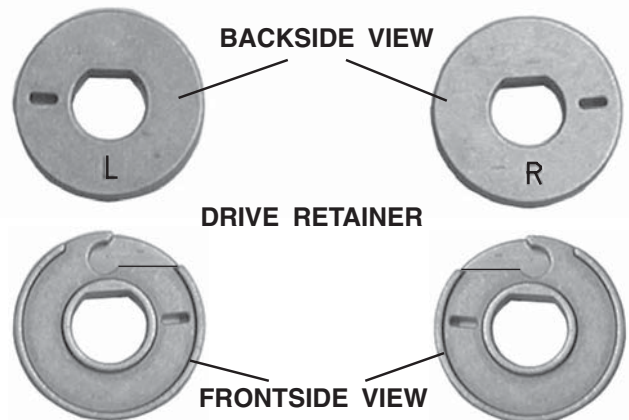

HOW IT WORKS: The pinion assemblies are mounted on the gearbox drive shaft. When there is no power to the gearbox shaft, the Torsion Spring holds the Pawl in the disengaged position. When there is power to the gearbox shaft, the friction between the bearing support and the drive disc overcomes the Torsion Spring, and the Pawl can engage one of the three TABs inside the Pinion Gear. You can disassemble these parts to remove contamination. However, be very careful with the Torsion Spring. Any kinks or bends will keep it from functioning properly.

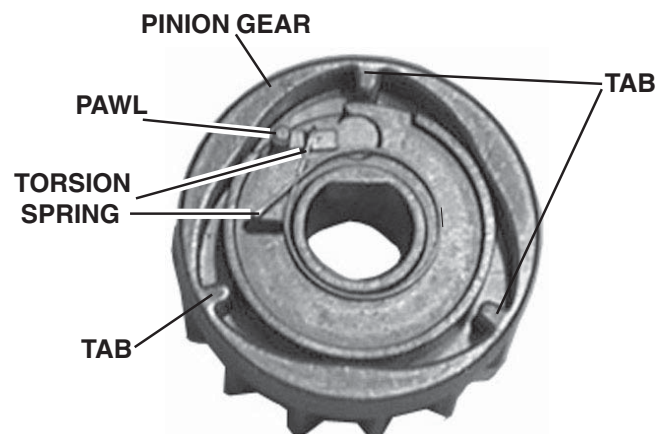

E Z WALK - DRIVE PINION SERVICING

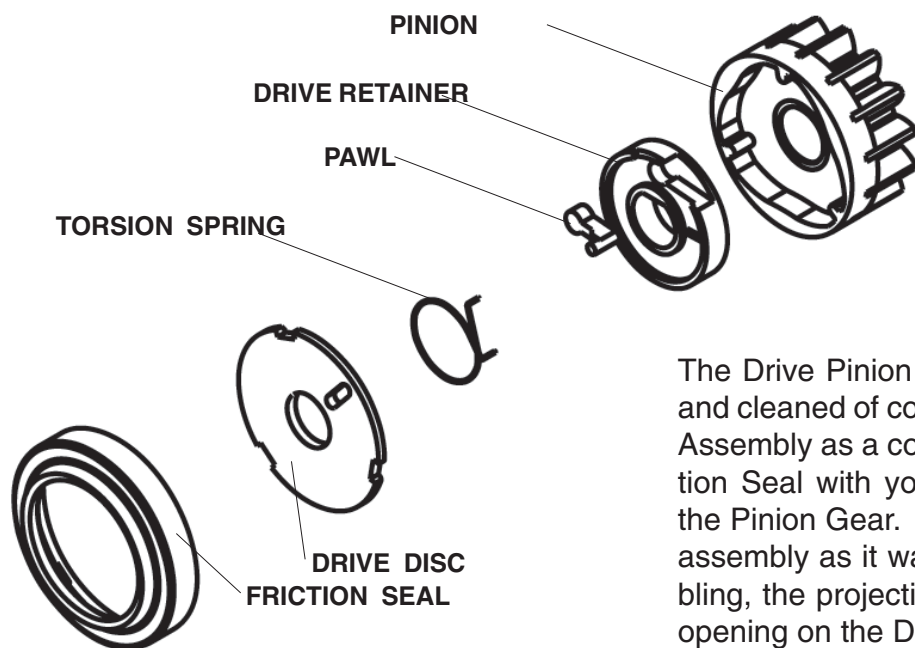

The Drive Pinion Assembly can be disassembled and cleaned of contamination. Remove the Pinion Assembly as a complete unit by grabbing the Friction Seal with your fingers, keeping pressure on the Pinion Gear. This will allow you to inspect the assembly as it was on the mower. When assembling, the projection on the Pawl must go into the opening on the Drive Disc.

NOTE: Make sure the Drive Disc is completely seated in the Friction Seal.

NOTE: No lubrication should be used on parts of the drive pinion assembly or the system may not drive. This includes the areas where the Friction Seal touches the Drive Disc and the Pinion Gear. The Friction Seal must set over the bearing support.

NOTE: Care must be taken not to change the shape of the Torsion Spring or the pinion will either not drive or not allow the operator to pull backwards. To increase the durability of the torsion spring, it is zinc plated to reduce corrosion.

NEW GEARBOX FOR FRONT DRIVE E Z

The EZ Walk front drive gearbox appears similar to gearbox for the rear drive, but is smaller.

174915 GEARBOX



NEW BLADE ADAPTER FOR FRONT DRIVE E Z WALK

A new 179606 blade adapter is used with the E Z Walk front drive when an engine spacer ring is used with Briggs or Tecumseh engines. The difference between the blade adapters in use are how far the crankshaft goes into the adapter. Use of a blade adapter other than the one specified in the parts listing can cause the mower not to meet standards for industry or CPSC.



E Z WALK - DRIVE CABLE REPLACEMENT

1. Remove four screws holding Drive Control Assembly and the Trim Plate to the upper handle. At a bench, remove the two T-15 screws holding the case together. Hold tightly so case will not spring apart. Carefully separate the case halves to remove the damaged cable and the internal parts. Discard the damaged cable and lay out the parts as shown. Only the rear drive mowers will have the Lever Return Spring.

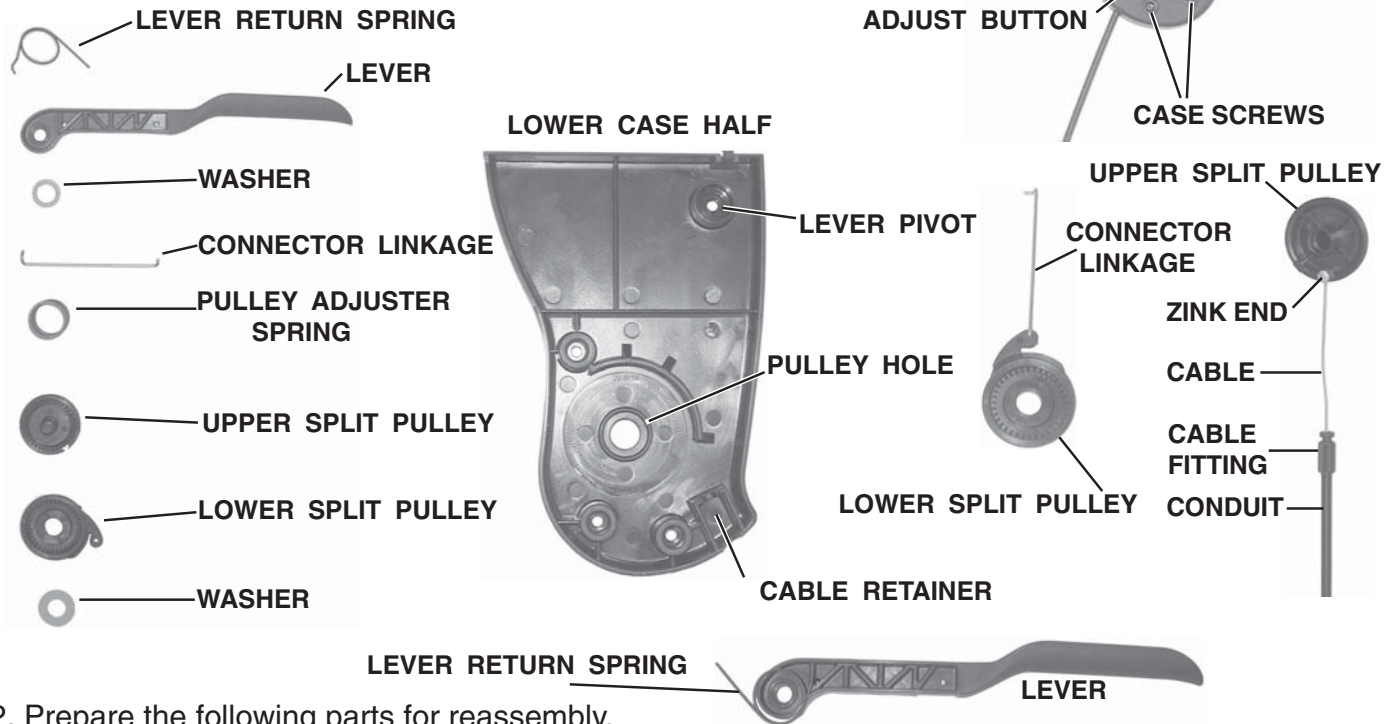

2. Prepare the following parts for reassembly.

- Locate the formed Zink End of the new Cable into the opening in the Upper Split Pulley.
- Assemble the Connector Linkage to the Lower Split Pulley. (Shown above right.)
- On rear drive mowers, locate the upturned end of the Lever Return Spring into the hole in the Lever.

3. Turn the Lever over as shown and place into the Lever Pivot boss in the Lower Case with the end of the spring against the straight rib at top of case half. Rotate Lever to proper position and hold lever in place. On front drive models, place the lever in the case without the Lever Return Spring. Place small Washer into the Pulley Hole.

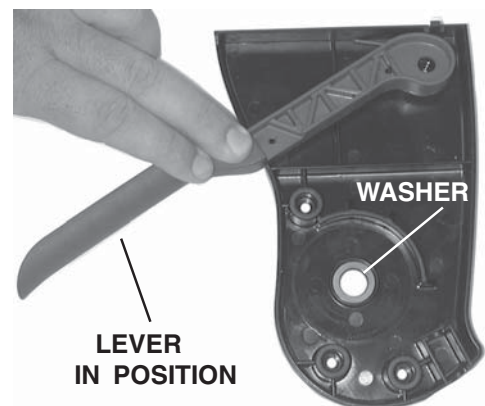
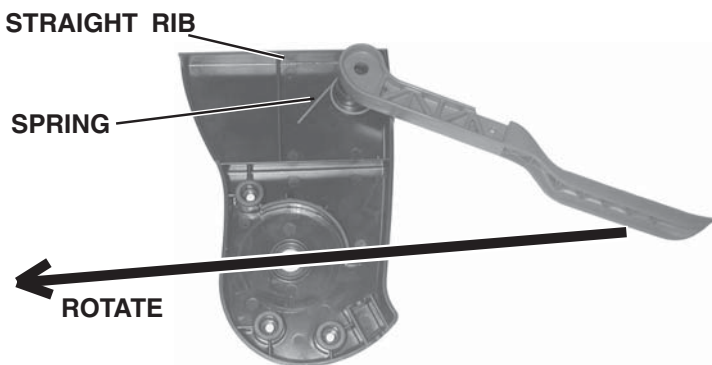

E Z WALK - DRIVE CABLE REPLACEMENT

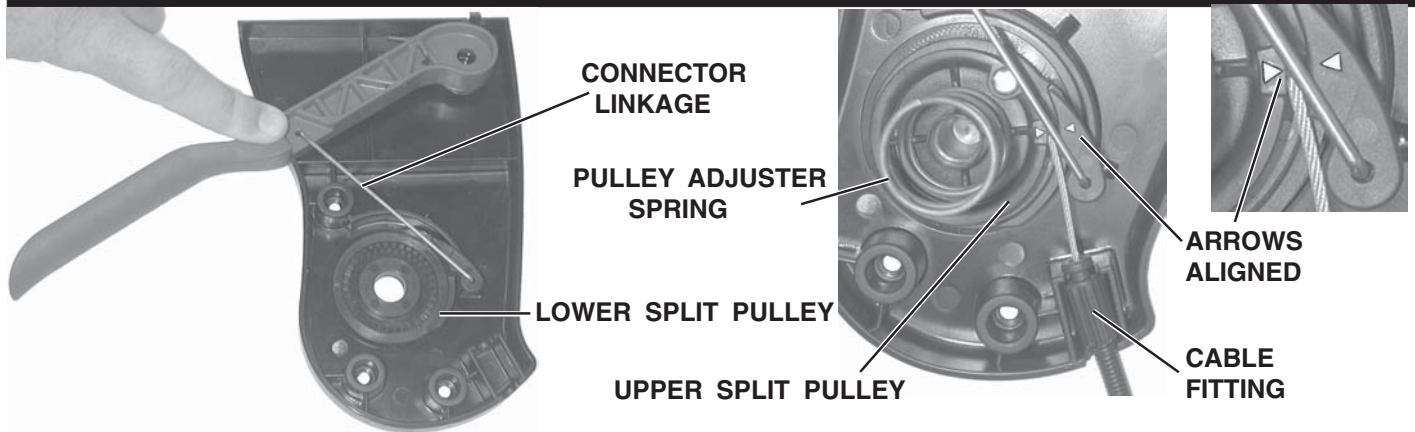

4. Install the Connecting Linkage into the Lever and place the Lower Split Pulley into the Pulley Hole.

5. Locate the fitting of the new Cable into the cable retainer boss of the Upper Case. Place the Upper Split Pulley into the Lower Split Pulley and align the arrows on the pulleys. Place the Pulley Adjuster Spring and Washer over the Lower Split Pulley.

6. Place the Upper Cover over the assembled parts and snap into place. Use two T-15 screws to hold the Drive Control together. Use four screws to hold Drive Control to the Upper Handle. Screws should be torqued to 18 Inch Pounds. If screws are over torqued, binding may keep the lever from proper movement.

7. Remove the spark plug wire from the spark plug.

8. If the mower is a Front Drive, remove the front drive cover. Turn the mower on its side, carburetor up. Use needle nose pliers to remove the snap in cable fitting from the underside of the mover. Install the spring into the gearbox bracket before snapping the new cable fitting into place.

9. If mower is a Rear Drive, remove the Rear Drive Cover. Use a needle nose pliers to remove the old cable snap in fitting. Remove spring at end of cable from the idler bracket. Install the new cable spring onto the idler bracket and snap cable fitting into bracket.

10. Reinstall Spark Plug Wire and Drive Covers. Perform the Drive Cable Adjustment procedure.

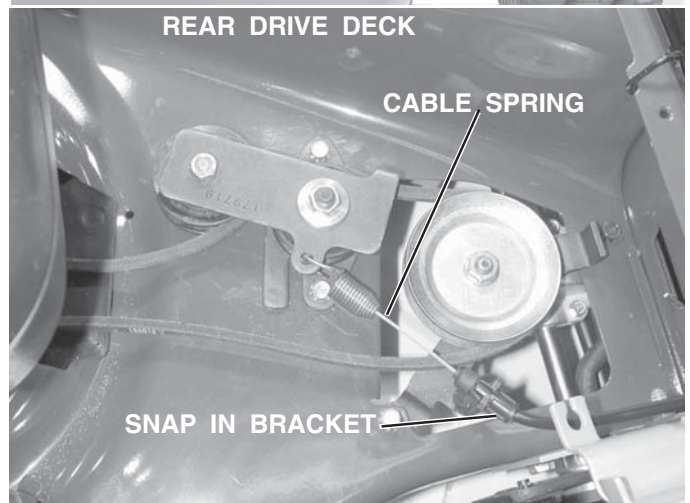
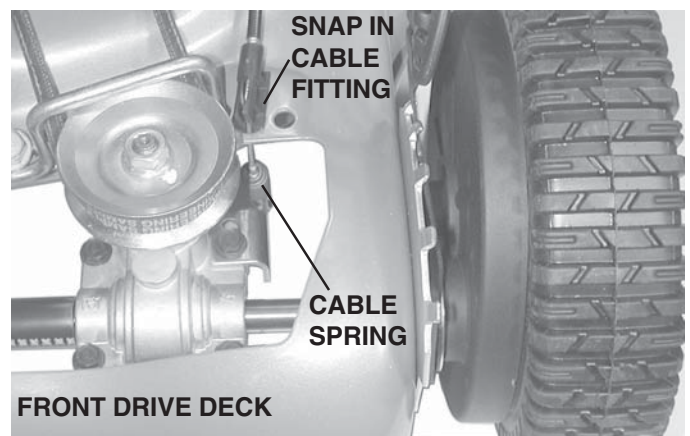

BELT REPLACEMENT ON E Z WALK FRONT DRIVE

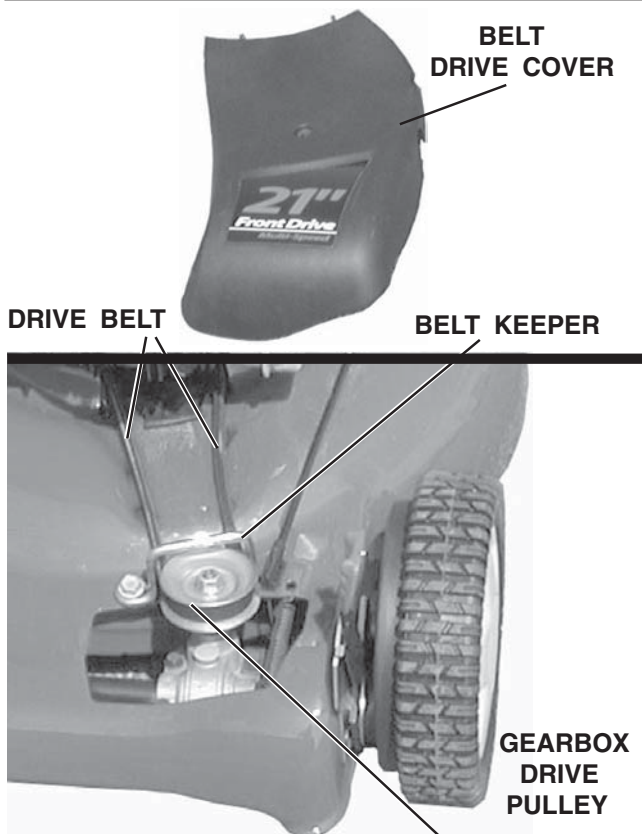

1. Remove spark plug wire from spark plug. Remove screw holding belt drive cover and the belt drive cover.
2. Remove nut holding gearbox pulley. Remove upper half of Pulley and Drive Belt.
3. Turn mower on side with carburetor up. Remove blade and bottom belt cover. **NOTE:** Protect your hands from sharp edge of blade with work gloves or by wrapping blade with protective material.
4. Install new belt on crankshaft pulley and through opening in deck. Reinstall the bottom belt cover being careful to keep belt in crankshaft pulley. Install blade and torque the blade bolt to 40 Ft.Lbs.
5. Return mower to position with four wheels on ground. Install belt through belt guide onto pulley. Torque pulley nut to 14 to 20 Ft.Lbs. Reinstall drive belt cover and screw. Replace wire on spark plug.

BELT REPLACEMENT ON E Z WALK REAR

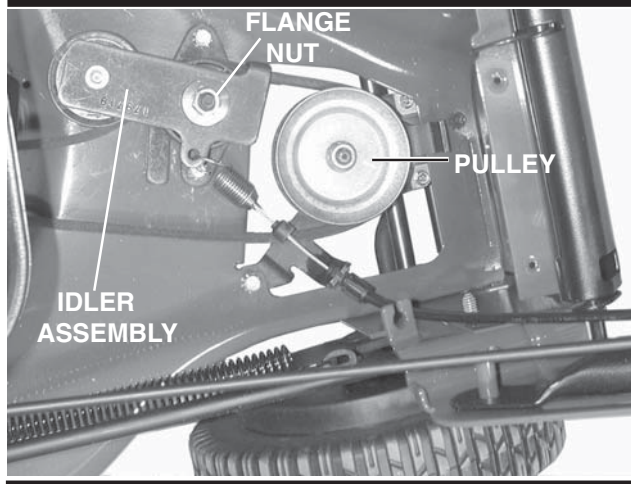

1. Disconnect the spark plug wire from the spark plug and place where it cannot touch plug. Remove Drive Cover at rear of housing.
2. Remove nut holding gearbox pulley, remove upper half of split pulley, and remove Flange Nut holding Idler Assembly to remove belt.
3. Turn mower on side with carburetor up. Remove Blade and Bottom Belt Cover. **NOTE:** Protect your hands from sharp edge of blade with work gloves or by wrapping blade with protective material.
4. Install new belt on crankshaft pulley and through opening in deck. Reinstall the bottom belt cover, and blade. Torque the blade bolt to 40 Ft.Lbs.
5. Return mower to position with four wheels on ground. Install Belt onto Pulley and torque pulley nut to 14 to 20 Ft.Lbs. Install Washer, Idler Bracket, and Flange Nut. Reinstall drive belt cover. Replace wire on spark plug.

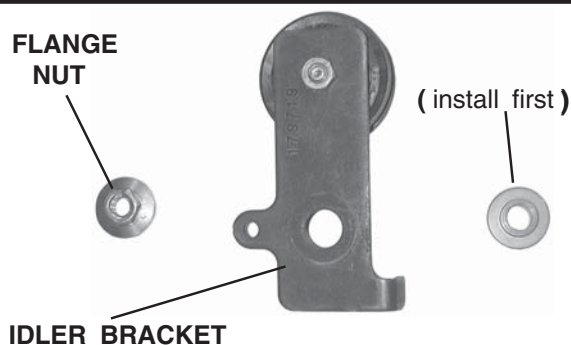

HONDA ENGINES WITH BLADE BRAKE CLUTCH

In 2002, HONDA Engines with a HONDA Blade Brake Clutch (BBC) will be available on some lawn mowers from EHP. The Blade Bolts are part number 180460 (M10-1.25 x 16 Class 10.9 Hex Bolt with nylon patch) and should be torqued at 36-43 Foot Pounds. A 15 mm socket is recommended. The 180459 blade is used with the HONDA BBC. Torque the BBC Bolt at 37 to 43 Ft.Lbs.

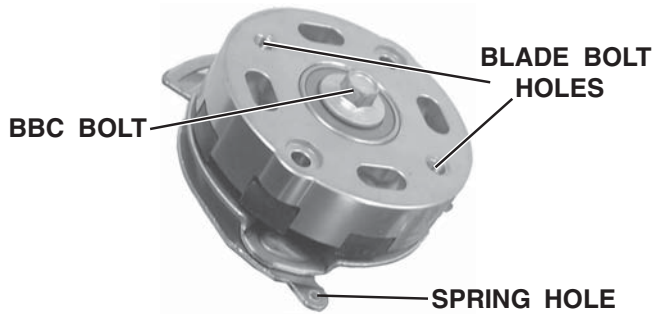

The bail is designed to keep the BBC from actuating when the Operator Presence Bail is not engaged. The offset in the Bail seen here is required to meet industry standards. Do not use a bail other than the one specified in the parts listing. Test mowers with BBC to see that the engagement control cannot be actuated unless Operator Presence Bail is against the handle.

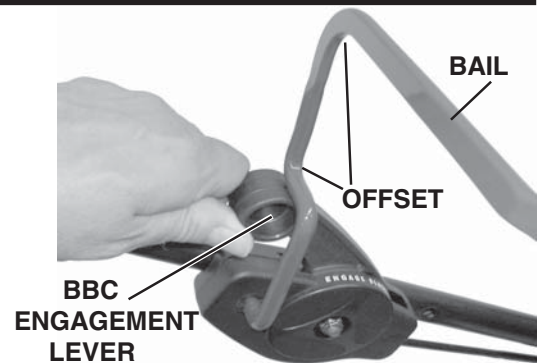

REAR DRIVE BELT REPLACEMENT WITH HONDA BBC

To replace the drive belt:

1. Remove Spark Plug Wire and secure away from the spark plug.
2. Follow directions to remove belt under drive cover on Rear Drive.
3. Remove blade using protection from sharp mower blade.
4. Remove bottom cover.
5. Remove end of BBC Engagement Cable from Blade Brake Clutch.
6. Remove Spring from both ends of Torque Link.
7. With CAUTION, use a long phillips head screwdriver to push end of Link out of either hole. The spring tension will be released.
8. Remove BBC Spring.
9. Remove belt around BBC and install new belt.
10. Install BBC Spring.
11. Position Link and rotate BBC to load spring until you can slide the link into place.
12. Reverse numbers 6 to 1.

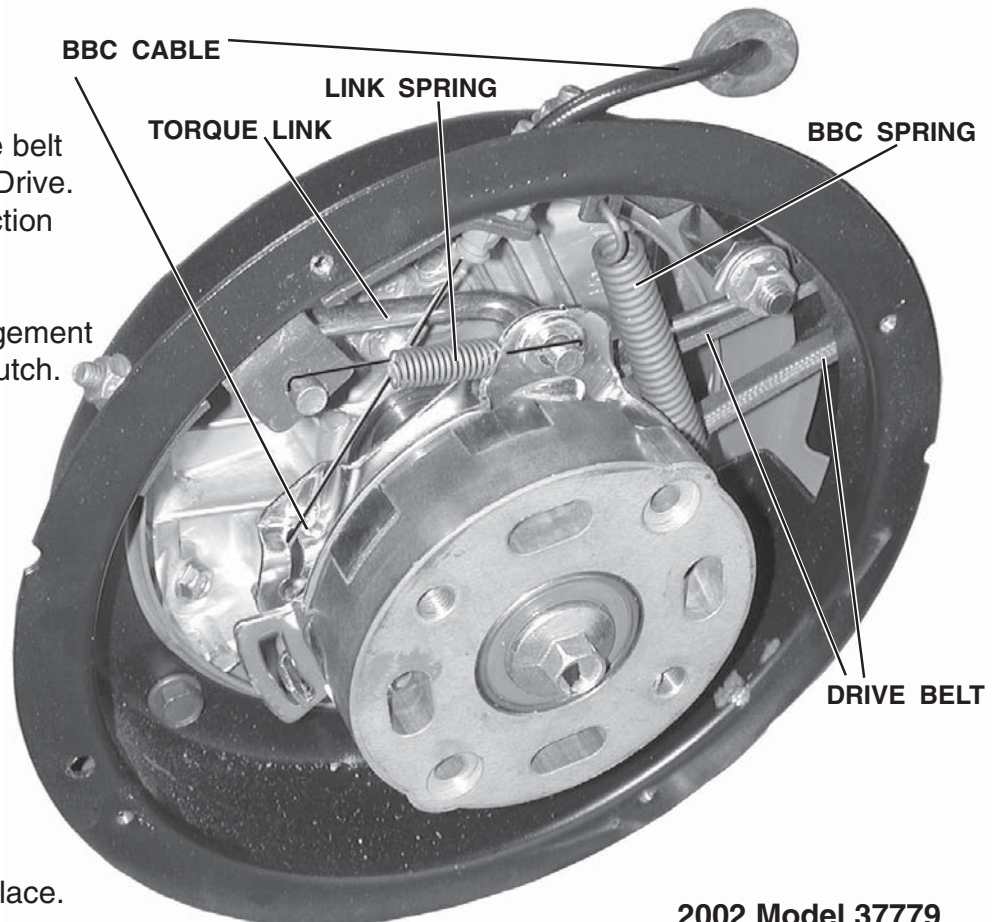

2002 Model 37779

REMOVABLE KEY ON ELECTRIC START

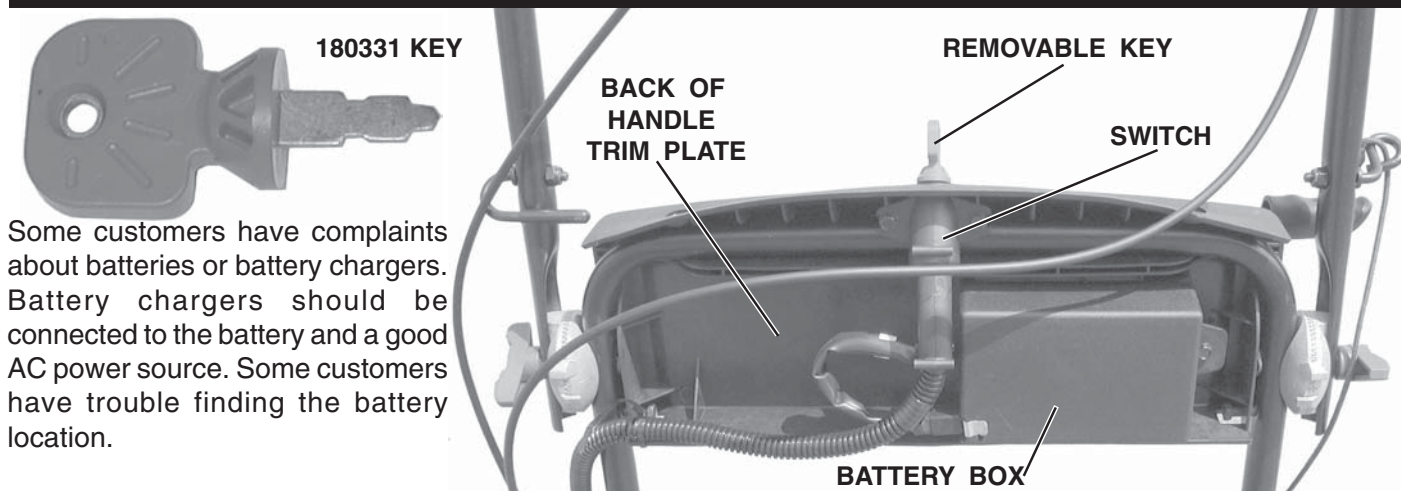

Some customers have complaints about batteries or battery chargers. Battery chargers should be connected to the battery and a good AC power source. Some customers have trouble finding the battery location.

NEW ELECTRIC START CONNECTOR ON BRIGGS ENGINES

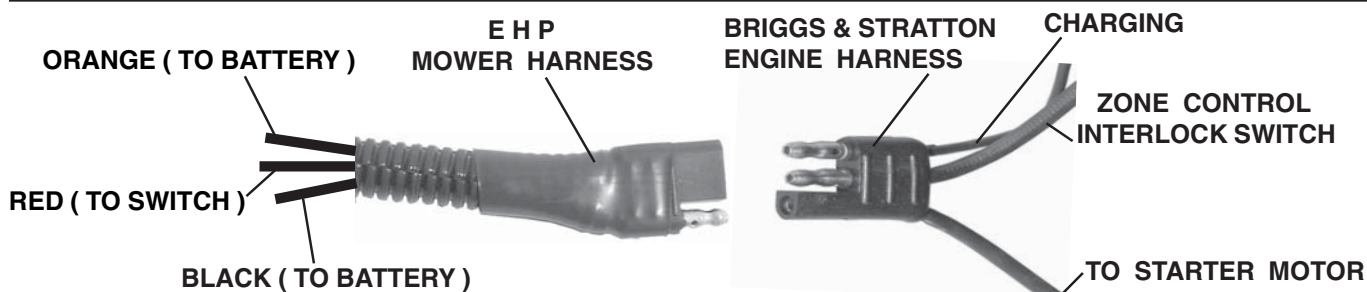

GRASS CATCHER IMPROVEMENT

Most grass catchers in the past have been held onto lawn mowers by a wireform. On some models, it has been found that a stamped part holding the grass catcher onto the mower reduces grass blowout. This change will be made to rear discharge lawn mowers where it will reduce grass blowout.



DRIVE WHEELS AND DUST COVERS

The drive wheels and dust covers have been changed for 2002. The position of the dust cover rib in the wheel has moved from next to the gear teeth to the very outside diameter of the hub, against the tread. This will require the dust cover to be 1/4" larger in diameter. The new Dust Cover 180504 must be used with the new wheels.

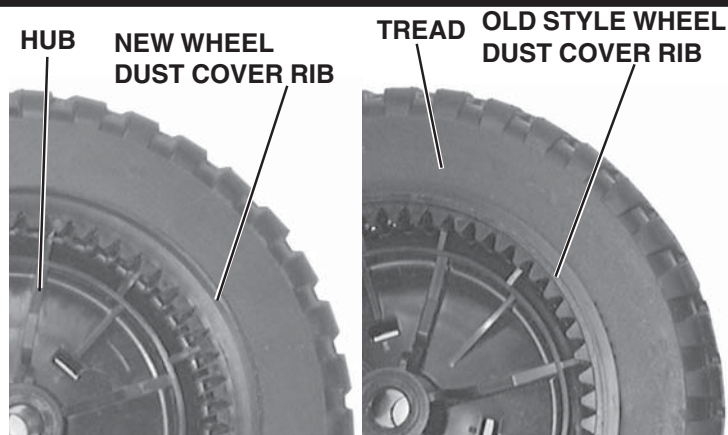

HIGH WHEEL TRIMMER CUTTER BALL SCREW

The screw holding the ball to the spindle has been improved. The new screw part number 180334 has a recessed hex head with washer. The previously used screw had an allen head and a separate washer. Both parts are 1/4" x 20 and the new part can be used in place of the old screw.

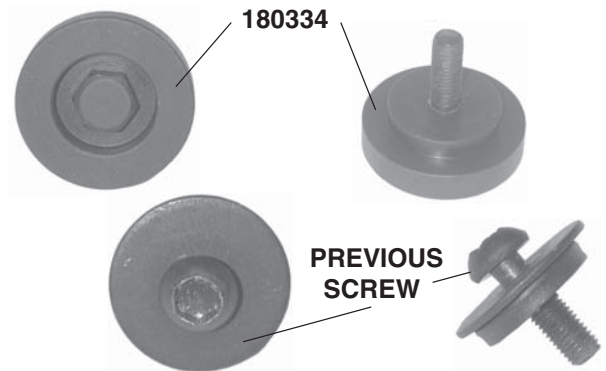

HIGH WHEEL TRIMMER SKIRT

There will no longer be a replaceable skirt on the high wheel trimmer shield. The shield will be made larger to include the area of the skirt.

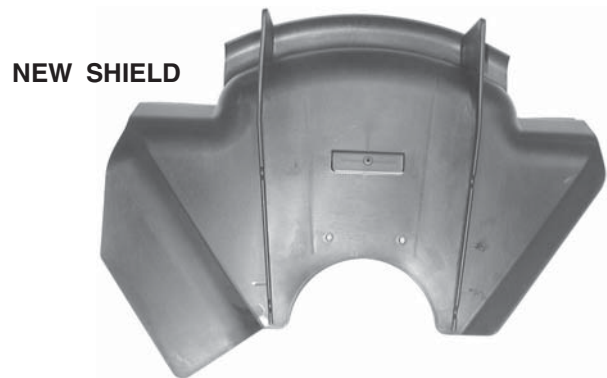

DRIVE ENGAGEMENT CONTROL ON FGD MOWERS

There is a new Drive Engagement Control for single speed frontwheel gear drive mowers. The new lever will be distinctively different from the one used in the past. In addition, an improved conduit will be used. The conduit will be vinyl with two reinforcing wires molded in parallel to the cable. This will better resist the damage from improperly folded handles see on the previously used conduit with wound reinforcing wire.

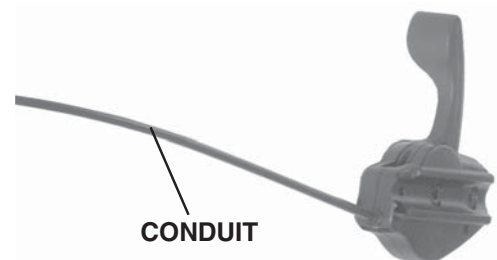

NEW GEARBOX - SINGLE SPEED FRONT GEAR

A new gearbox with a plastic case will be used on 2002 single speed front gear drive mowers. This gearbox will be serviceable as an assembly. The same belt, pulley, and cable will be used as with the transmission with aluminum gearcase.



*** BLADE LISTING ***
by RETAINER HOLE CHARACTERISTICS

PART NUMBER	DECK SIZE	CONSTRUCTION	TYPE	DECK TYPE	HOLE(S)	BLADE BOLT(S)	RETAIL NUMBER
145106	20"	REGULAR	MULCH		3	1	71-33255
146749	20"	PREMIUM	MULCH		3	1	71-33271
701211	20"	PREMIUM	STANDARD		3	1	71-33270
850972	20"	REGULAR	STANDARD		3	1	71-33233
154208	20"	ELECTRIC	MULCH	CAST DECK	3	1	
156716	20"	ELECTRIC	MULCH	REAR DISCHARGE	3	1	
175064	21"	REGULAR	MULCH / BAG		3	1	71-33275
176135	21"	PREMIUM	MULCH / BAG		3	1	
175052	21"	REGULAR	MULCH only		3	1	
180459	21"	REGULAR	MULCH / BAG	BBC	3	2	
152202	22"	REGULAR	MULCH	SIDE DISC EZ3	3	1	
141114	22"	REGULAR	MULCH		3	1	71-33256
141443	22"	PREMIUM	MULCH		3	1	71-33272
701213	22"	PREMIUM	STANDARD		3	1	71-33223
850973	22"	REGULAR	STANDARD		3	1	71-33234
140101	36"	REGULAR	MULCH		STAR	1	
138496	36"	REGULAR	HI LIFT		STAR	1	
138970	38"	PREMIUM	HI LIFT		STAR	1	
138497	38"	REGULAR	HI LIFT		STAR	1	71-24671
139774	38"	PREMIUM	MULCH		STAR	1	
134148	38"	REGULAR	MULCH		STAR	1	71-24692
138971	42"	PREMIUM	HI LIFT		STAR	1	71-24652
138498	42"	REGULAR	HI LIFT		STAR	1	
139775	42"	PREMIUM	MULCH		STAR	1	71-24655
134149	42"	REGULAR	MULCH		STAR	1	71-24676
130652	44"	PREMIUM	STANDARD		STAR	1	71-24678
152443	46"	PREMIUM	MULCH / BAGGING		STAR	1	71-24004
176084	46"	PREMIUM	DISCHARGE / BAGGING		STAR	1	71-24015
159705	46"	PREMIUM	BAHIA		STAR	1	
180054	48"	PREMIUM	Discharge / Bagging		STAR	1	71-33906
173921	48"	PREMIUM	MULCH		STAR	1	
137380	50"	PREMIUM	STANDARD		STAR	1	71-24005
156468	50"	PREMIUM	STANDARD-THICK		STAR	1	

BLADE PART NUMBERS WITHIN SHADED AREAS ARE INTERCHANGABLE.
 CONSTRUCTION - BLADES INDICATED AS PREMIUM ARE MADE OF BETTER STEEL WITH
 A BETTER HEAT TREAT PROCESS TO RESIST SAND ABRASION.

May 2002 -

NOTES

For Husqvarna Parts Call 606-678-9623 or 606-561-4983

182208 MADE IN THE USA

www.mymowerparts.com