



SERVICE 		12
		97-04-10

Workshoptool for dismantling/replacing the chain sprocket, 250PS

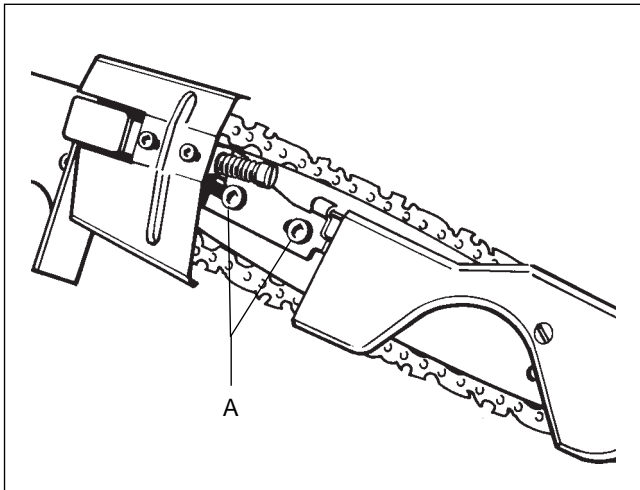

Remove both bolts "A".

Then lift off the entire cutting equipment including the chain sprocket guard and the guard over the chain.

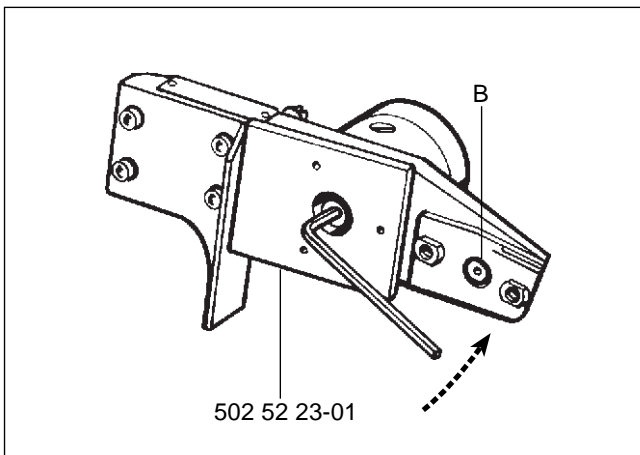

Place the tool 502 52 23-01 in position over the chain sprocket as shown in the illustr. Ensure the studs grip in the sprocket.

Loosen the sprocket by turning the hydraulic motor's axle counter-clockwise.

Assembly takes place in the reverse order as dismantling.

Check that the O-ring "B" is not damaged and is in position.

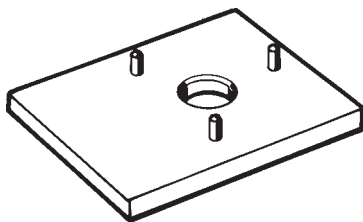

502 52 23-01