

For Husqvarna Parts Call 606-678-9623 or 606-561-4983

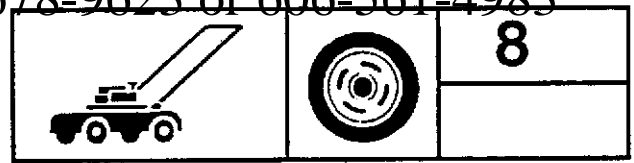

# CRT50

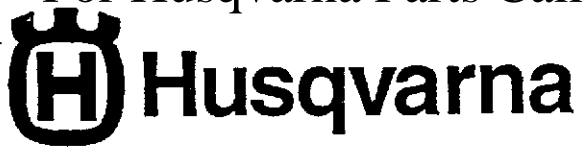
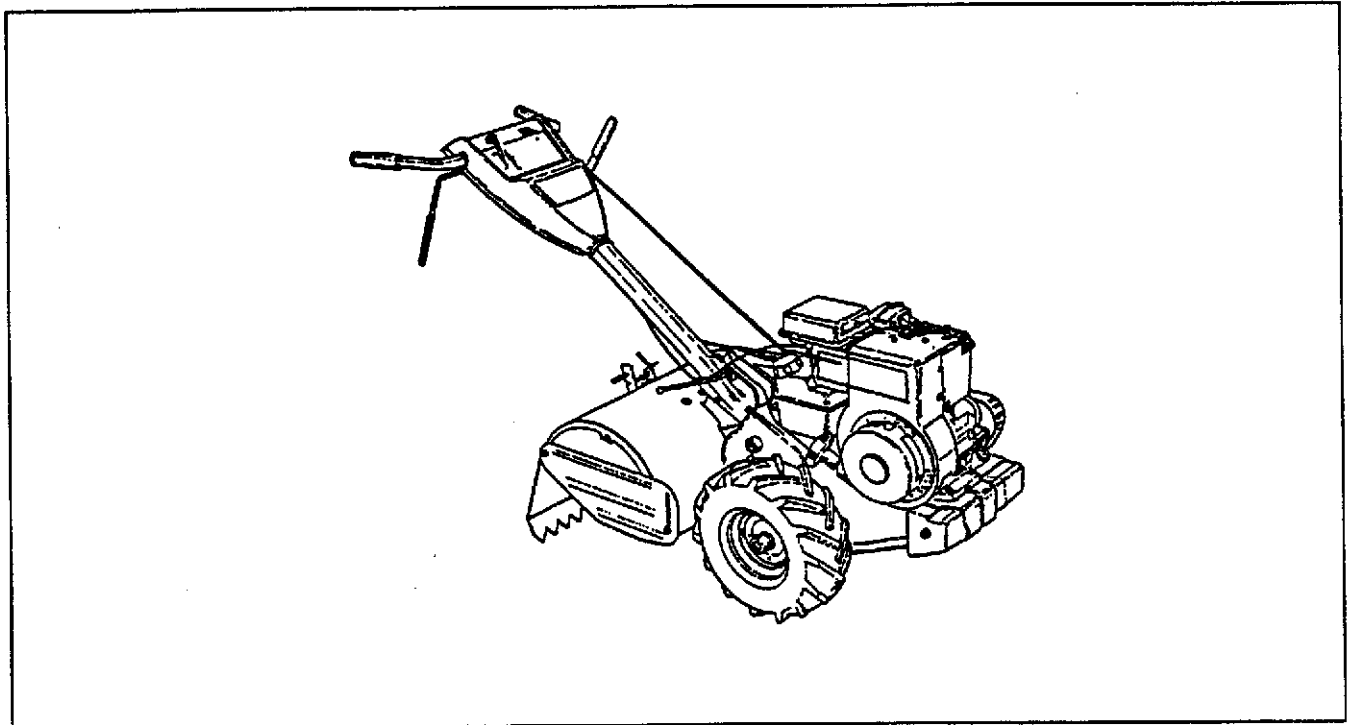

**1.1992**

**Spare parts**

**Pièces détachées**

HRT5C

532 13 64-74

**REPAIR PARTS** For Husqvarna Parts Call 606-678-9623 or 606-561-4983  
**5 HP 17" TILLER -- MODEL NO. CRT50, PRODUCT NO. 954 00 03-82 (HRT5C)**  
**HANDLE ASSEMBLY**

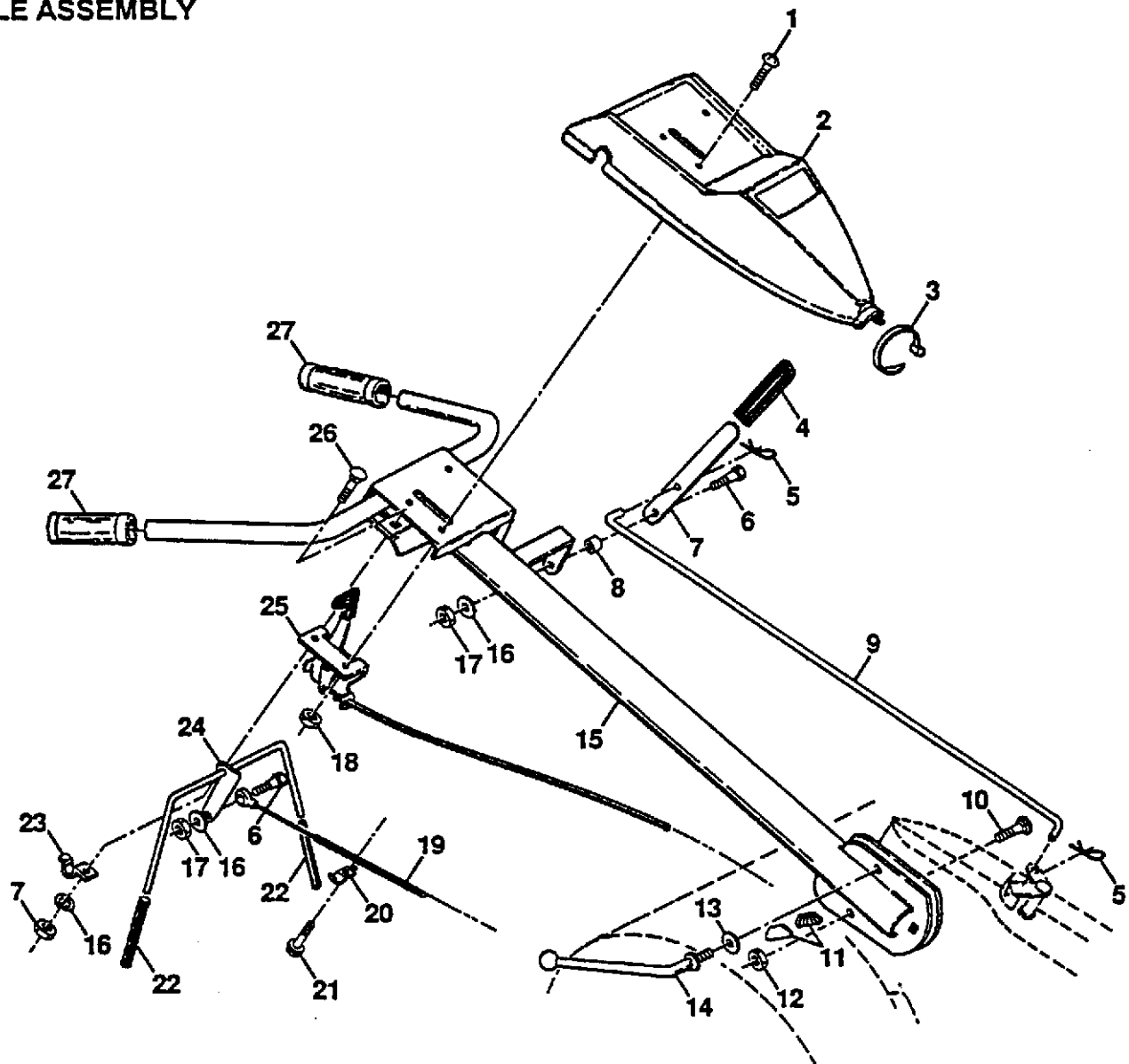

KEY NO.	PART NO.	DESCRIPTION	KEY NO.	PART NO.	DESCRIPTION
1	871091008	Screw, Truss Hd. #10-24 UNC x 1/2	18	873731000	Nut, Keps #10-24 UNC
2	532126956	Panel, Control	19	532102162	Cable, Clutch
3	532104164	Tie, Cable	20	532009484	Clip
4	532124797	Grip, Handle	21	532086777	Screw, Hex Washer Hd. Slotted #10-24 x 1/2
5	532124788	Clip, Hairpin	22	532102604	Grip, Bar, Control
6	532081328	Bolt, Shoulder	23	532102744	Clamp, Bar, Control
7	532109335	Handle, Shift	24	532105216	Bar Assembly, Control
8	532109313	Grommet, Rubber	25	532127012	Control, Throttle
9	532109337	Rod, Shift	26	872140404	Bolt, Carriage 1/4-20 UNC x 1/2
10	872110608	Bolt, Carriage 3/8-16 x 1 Gr. 5	27	532009266	Grip, Handle
11	532109229	Lock, Handle	--	532132340	Manual, Operator's (English)
12	532005394	Nut 3/8-16	--	532132341	Manual, Operator's (French)
13	819131611	Washer 13/32 x 1 x 11 Ga.	--	532104322	Decal, Instruction
14	532109228	Lever, Lock, Handle	--	532124264	Decal, Control Panel
15	532125011	Handle	--	532110614	Decal, Hand Placement
16	810040400	Washer, Lock 1/4			
17	873220400	Nut, Hex 1/4-20			

**NOTE:** All component dimensions given in U.S. inches.  
 1 inch = 25.4 mm

# REPAIR PARTS

5-HP 17" TILLER - - MODEL NO. CRT50, PRODUCT NO. 954 00 03-82 (HRT5C)

## MAINFRAME, LEFT SIDE

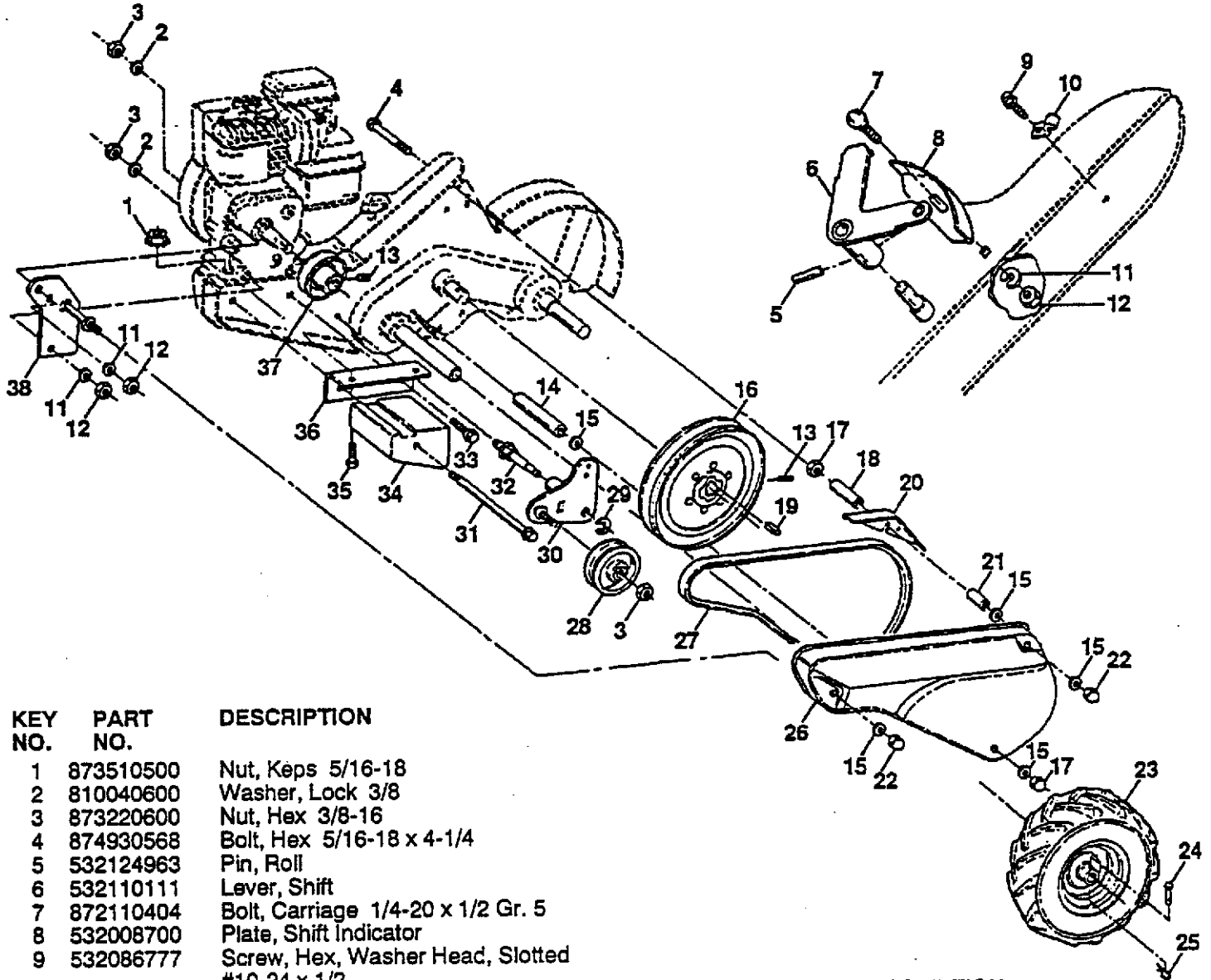

KEY NO.	PART NO.	DESCRIPTION
1	873510500	Nut, Keps 5/16-18
2	810040600	Washer, Lock 3/8
3	873220600	Nut, Hex 3/8-16
4	874930568	Bolt, Hex 5/16-18 x 4-1/4
5	532124963	Pin, Roll
6	532110111	Lever, Shift
7	872110404	Bolt, Carriage 1/4-20 x 1/2 Gr. 5
8	532008700	Plate, Shift Indicator
9	532086777	Screw, Hex, Washer Head, Slotted #10-24 x 1/2
10	532009484	Clip
11	810040400	Washer, Lock 1/4
12	873220400	Nut, Hex 1/4-20
13	823230506	Screw, Set, Hex 5/16-18 x 3/8
14	532120938	Spacer, Split 0.327 x 0.42 x 2.68
15	819111116	Washer 11/32 x 11/16 x 16 Ga.
16	532100473	Sheave, Transmission
17	873220500	Nut, Hex 5/16-18
18	532110651	Spacer, Split 0.327 x 0.42 x 1.75
19	532002649	Key, Square 3/16 x 1-1/8
20	532110653	Guard, Pinch Point
21	532131691	Spacer, Split 0.327 x 0.42 x 1.627
22	532104214	Nut, Cap 5/16-18
23	532102190	Tire
	532124258	Rim
	532124718	Tire Valve
24	532126875	Rivet, Drilled
25	532124788	Clip, Hairpin
26	532125339	Guard, Belt

KEY NO.	PART NO.	DESCRIPTION
27	532132672	Belt, V
28	532104679	Pulley, Idler
29	812000032	Ring, Klip
30	532105611	Bracket, Idler
31	532102384	Bolt, Hex 5/16-16 x 12
32	532102141	Shaft, Idler Arm
33	874760616	Bolt, Hex 3/8-16 x 1
34	532102383	Counterweight, L. H.
35	874760524	Bolt, Hex 5/16-18 x 1-1/2
36	532102331	Bracket, Reinforcement, L. H.
37	532130816	Sheave, Engine
38	532131558	Bracket, Guard Belt
--	532104323	Decal, Shift Indicator
--	532124265	Decal, Logo (Belt Guard)

NOTE: All component dimensions given in U.S. inches.  
1 inch = 25.4 mm

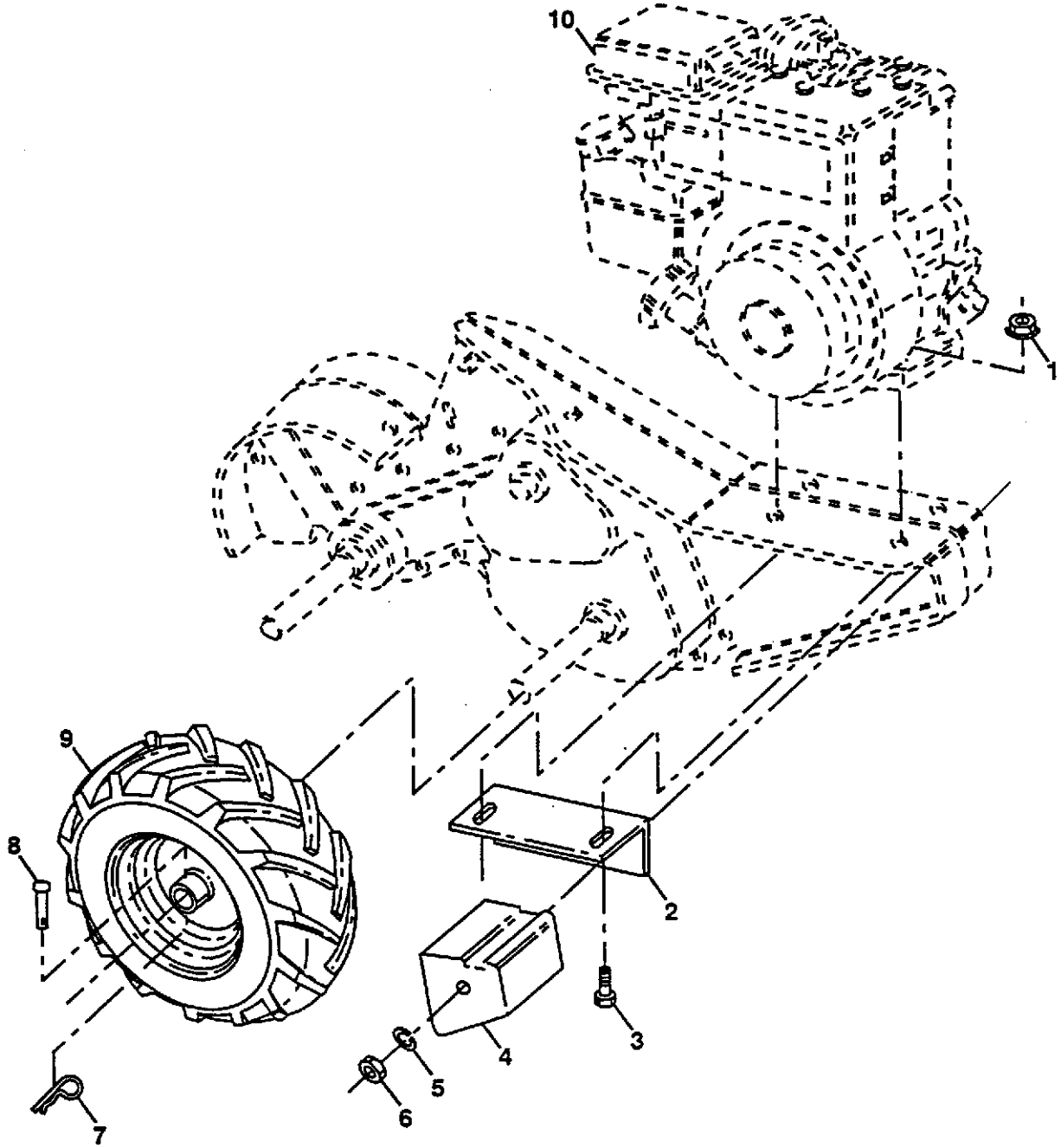

KEY NO.	PART NO.	DESCRIPTION
1	873510500	Nut, Keps 5/16-18
2	532102332	Bracket, Reinforcement
3	874760524	Bolt, Hex 5/16-18 x 1-1/2
4	532102173	Counter Weight, R.H.
5	810040600	Washer, Lock 3/8
6	873220600	Nut, Hex 3/8-16
7	532124788	Clip, Hairpin
8	532126875	Rivet, Drilled

KEY NO.	PART NO.	DESCRIPTION
9	532102190	Tire
	532124258	Rim
	532124718	Tire Valve
10	-----	Engine, Briggs & Stratton Model No. 130202
--	532121543	Decal, Engine
--	532110612	Decal, Caution (Top of Engine)

NOTE: All component dimensions given in U.S.inches.  
 1 inch = 25.4 mm

**REPAIR PARTS**  
**5 HP 17" TILLER - - MODEL NO. CRT50, PRODUCT NO. 954 00 03-82 (HRT5C)**  
**TRANSMISSION**

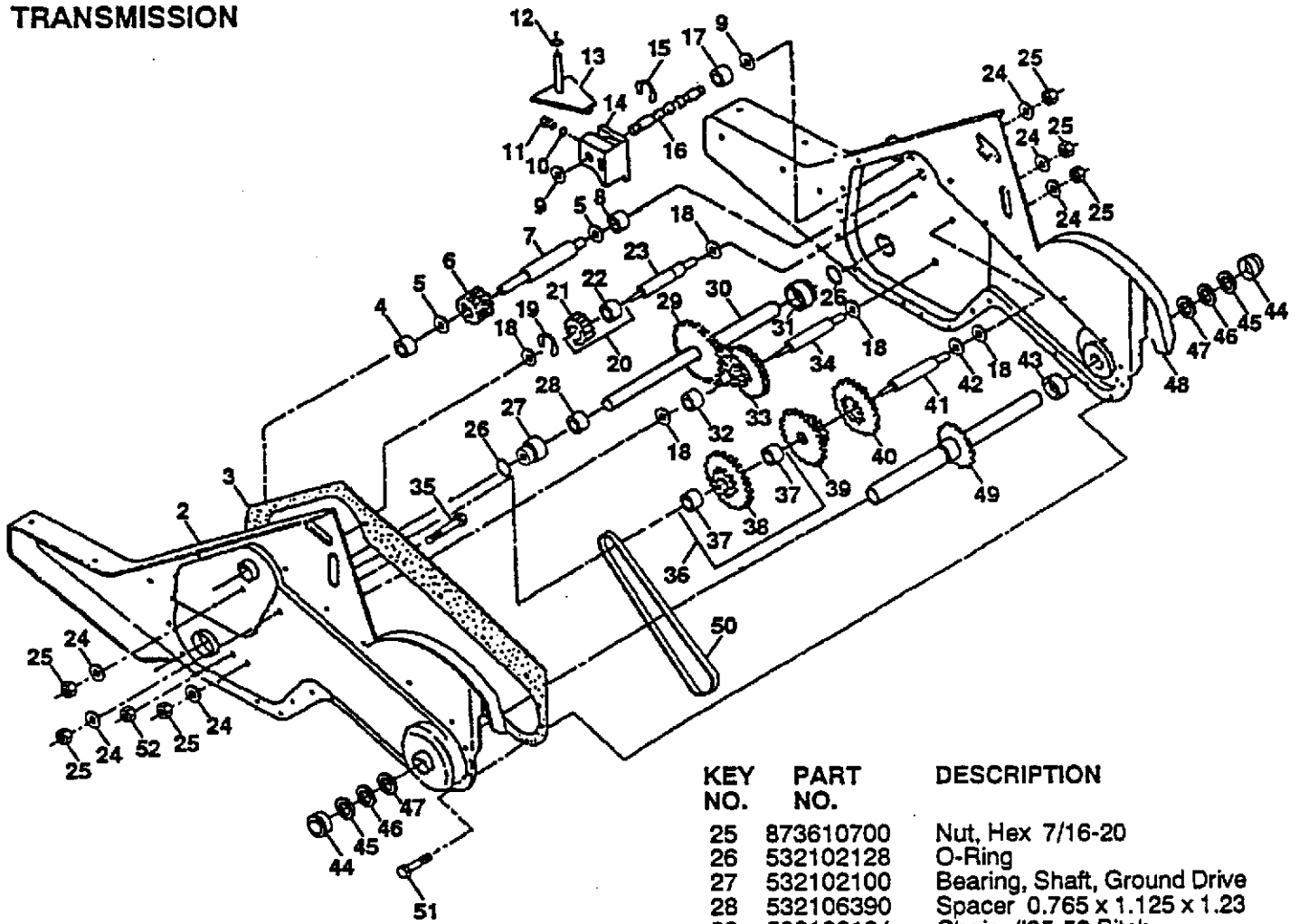

KEY NO.	PART NO.	DESCRIPTION
1	532132718	Transmission Assembly (Includes Key Nos. 2-52)
2	532121147	Gearcase, L.H. w/Bearing (Includes Key No. 4)
3	532106211	Gasket, Gearcase
4	532005020	Bearing, Needle
5	532001370	Washer, Thrust 5/8 x 1.10 x 1/32
6	532102113	Pinion, Input
7	532102110	Shaft, Input
8	532124792	Bearing, Needle
9	532102136	Washer, Seal
10	532124697	Ball, Steel
11	532100371	Spring, Shift, Fork
12	532106160	O-Ring
13	532102107	Arm, Shift
14	532008353	Fork, Shift
15	812000039	Ring, Klip
16	532102109	Shaft, Shift
17	532104159	Spacer, Split
18	532004358	Washer
19	812000040	Ring, Klip
20	532102114	Gear, Assembly, Reverse Idler (Includes Key Nos. 21 and 22)
21	532102115	Gear, Reverse Idler
22	532006803	Bearing, Needle
23	532102111	Shaft, Reverse Idler
24	810040700	Washer, Lock 7/16

KEY NO.	PART NO.	DESCRIPTION
25	873610700	Nut, Hex 7/16-20
26	532102128	O-Ring
27	532102100	Bearing, Shaft, Ground Drive
28	532106390	Spacer 0.765 x 1.125 x 1.23
29	532102134	Chain #35-50 Pitch
30	532109204	Ground Shaft Assembly
31	532102106	Bearing, Shaft, Ground Drive
32	532106388	Spacer 0.70 x 1.00 x 1.150
33	532102121	Sprocket and Gear Assembly
34	532102112	Shaft, Reduction (2nd)
35	532102101	Screw, Whiz, Lock 5/16-18 x 3-1/2
36	532106141	Sprocket Assembly w/Bearing (Includes Key Nos. 37 and 38)
37	532124791	Bearing, Needle
38	532106142	Sprocket, Tine
39	532105345	Gear, Cluster, Red 1st & 2nd
40	532105346	Gear, Reverse
41	532008358	Shaft, Reduction (1st)
42	532004220	Washer, Thrust
43	532106146	Spacer 1.01 x 1.75 x 0.760
44	532009672	Cup, Formed
45	532102144	Ring, Spiral
46	532009676	Seal, Ring, Rubber
47	532009674	Seal, Oil
48	532121745	Gearcase, R.H. w/Bearing (Includes Key No. 8)
49	532132688	Shaft, Tine
50	532106147	Chain, Roller #50-50 Pitch
51	817580408	Screw 1/4-20 x 1/2
52	873220500	Nut, Hex 5/16-18
--	532006066	Grease, Plastilube #1

NOTE: All component dimensions given in U.S. inches.  
 1 inch = 25.4 mm

**5 HP 17" TILLER -- MODEL NO. CRT50, PRODUCT NO. 954 00 03-82 (HRT5C)**  
**TINE SHIELD**

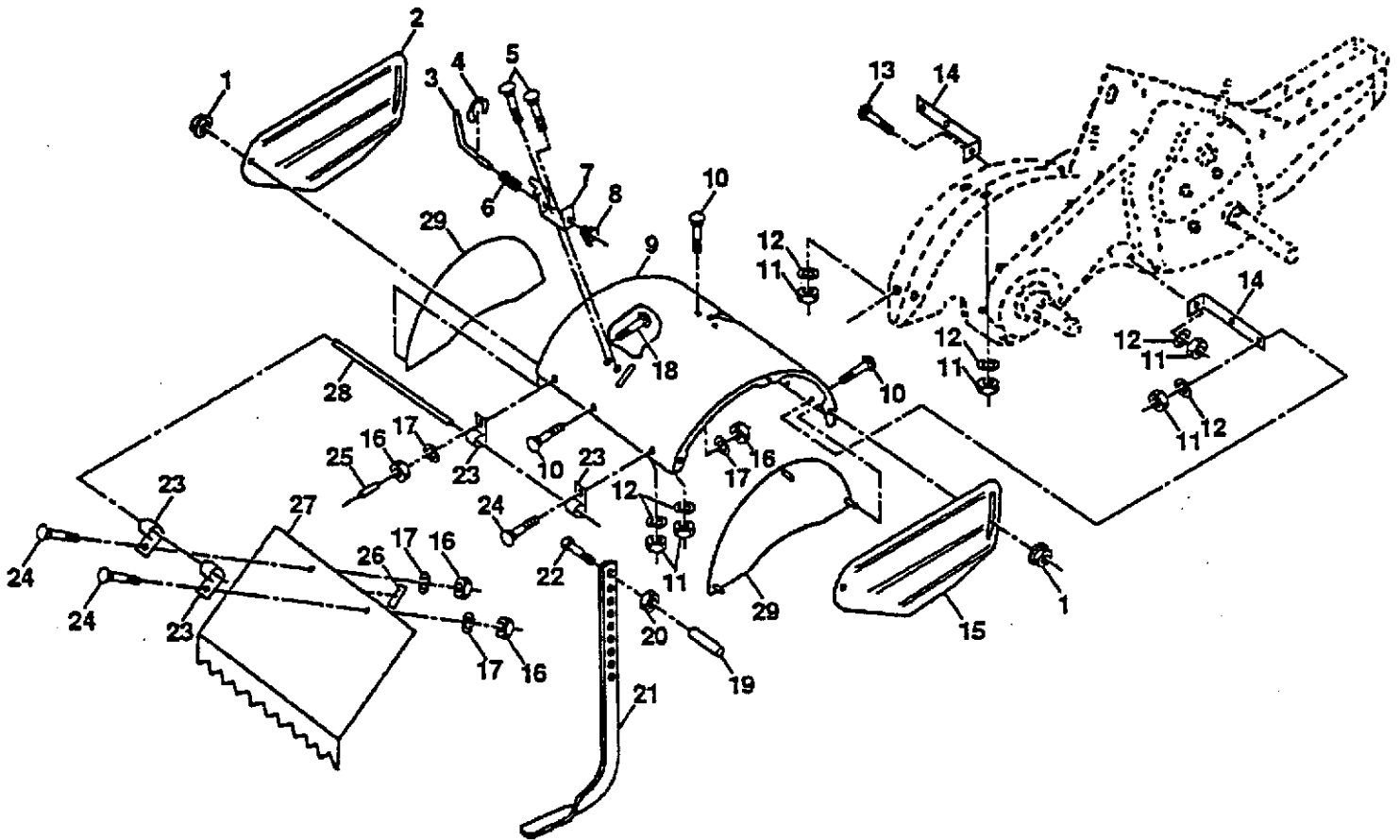

KEY NO.	PART NO.	DESCRIPTION
1	898000129	Nut, Flange 5/16-18
2	532125012	Shield, Side, Outer L. H.
3	532008393	Pin, Stake, Depth
4	812000036	Ring, Klip
5	872110508	Bolt, Carriage 5/16-18 x 1
6	532008394	Spring
7	532008392	Bracket, Latch
8	532109230	Spring, Depth Stake
9	532125014	Shield, Tine
10	872140506	Bolt, Carriage 5/16-18 x 3/4 Gr 5
11	873220500	Nut, Hex 5/16-18
12	810040500	Washer, Lock 5/16
13	872110510	Bolt, Carriage 5/16-18 x 1-1/4
14	532124343	Bracket, Shield Tine
15	532125015	Shield, Side, Outer R.H.
16	873220400	Nut, Hex 1/4-20
17	810040400	Washer, Lock 1/4

KEY NO.	PART NO.	DESCRIPTION
18	872040410	Bolt, Carriage 1/4-20 x 1-1/4 Gr. 5
19	532102701	Grip
20	873220600	Nut, Hex 3/8-16
21	532102156	Stake, Depth
22	874930632	Bolt, Hex 3/8-16 x 2
23	532004440	Hinge
24	872140404	Bolt, Carriage 1/4-20 x 1/2 Gr. 5
25	532124717	Cap, Vinyl
26	532109227	Pad, Idler
27	532125016	Shield, Leveling
28	532120588	Pin, Hinge
29	532125013	Shield, Side
--	532124263	Decal, Tine Shield
--	532120076	Decal, Warning (Leveling Shield)

**NOTE:** All component dimensions given in U.S. inches.  
 1 inch = 25.4 mm

5 HP 17" TILLER - - MODEL NO. CRT50, PRODUCT NO. 954 00 03-82

**TINE ASSEMBLY**

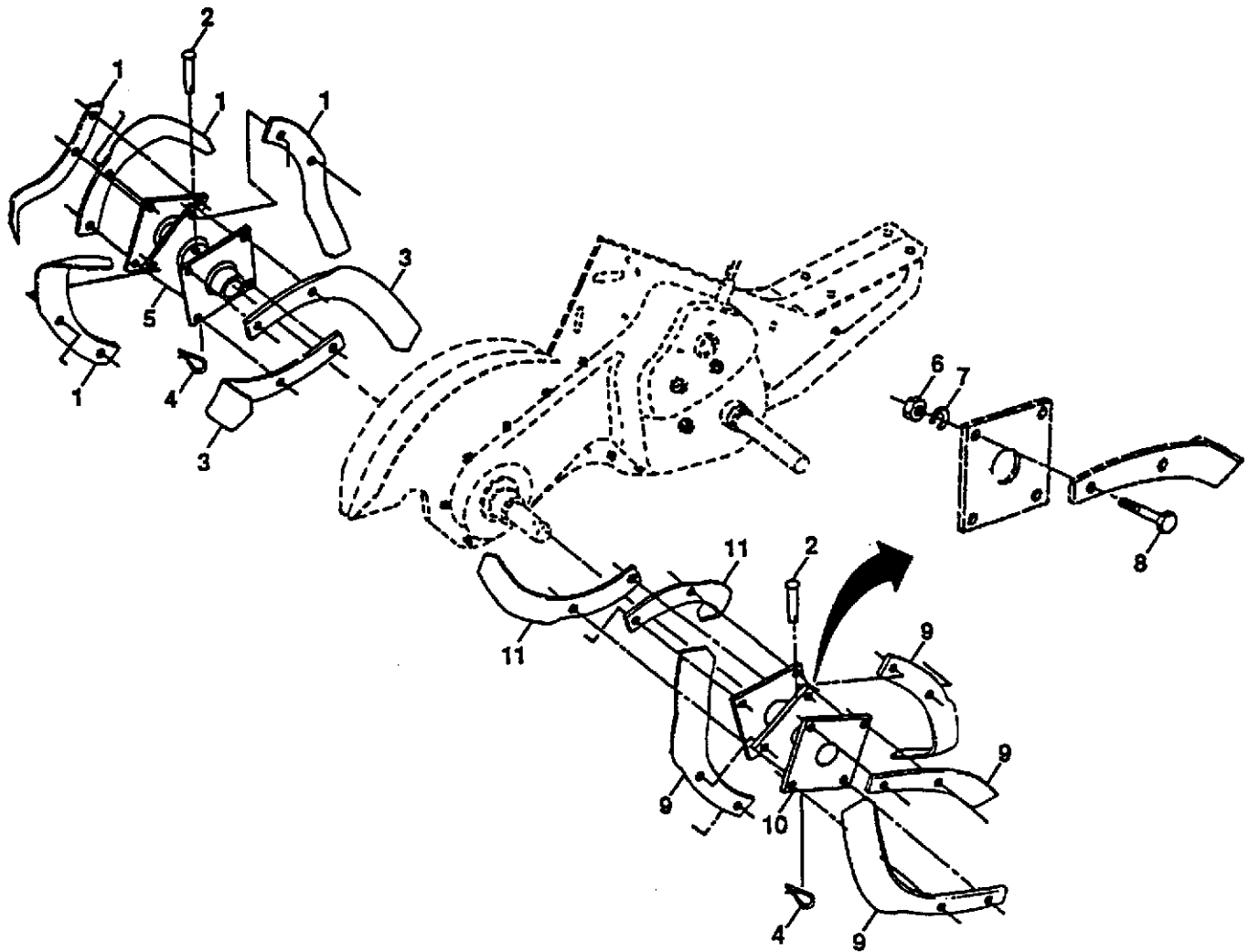

KEY NO.	PART NO.	DESCRIPTION
1	532004459	Tine, Outer, L.H.
2	532132673	Clevis Pin
3	532006554	Tine, Inner, L.H.
4	532124660	Clip, Hairpin
5	532132727	Assembly, Hub and Plate, L.H.
6	873610600	Nut, Hex 3/8-24
7	810040600	Washer, Lock 3/8

KEY NO.	PART NO.	DESCRIPTION
8	874610616	Bolt, Hex 3/8-24 x 1
9	532004460	Tine, Outer, R.H.
10	532132728	Assembly, Hub and Plate, R.H.
11	532006555	Tine, Inner, R.H.

**NOTE:** All component dimensions given in U.S. inches.  
 1 inch = 25.4 mm