

For Husqvarna Parts Call 606-678-9623 or 606-561-4983

ILLUSTRATED PARTS BREAKDOWN

5 HP 17" CRT

REAR TINE TILLER

MODEL NO. CRT50 (HRT5B)

954 00 02-71

127607 11.13.90

www.mymowerparts.com

5 HP 17" CRT TILLER -- MODEL NUMBER CRT50

HANDLE ASSEMBLY

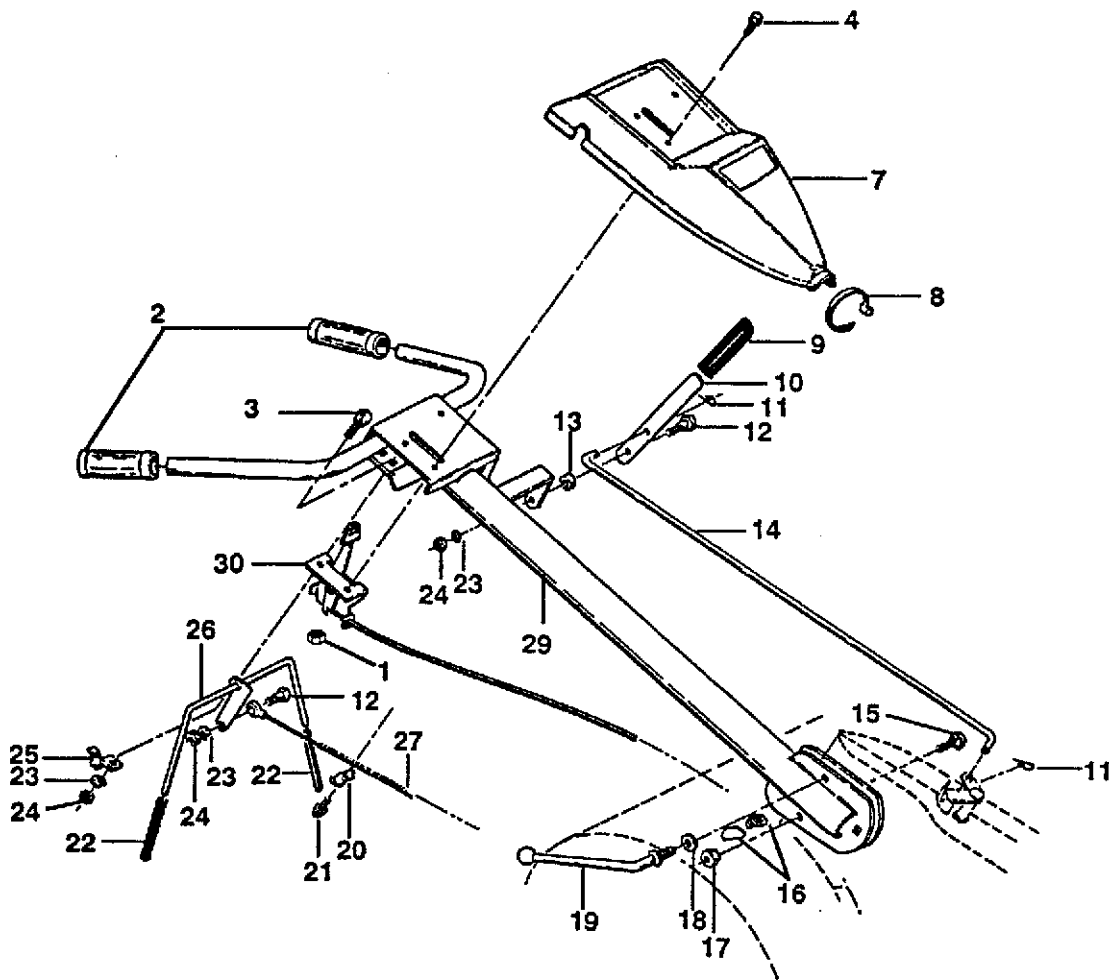

KEY NO.	PART NO.	DESCRIPTION	KEY NO.	PART NO.	DESCRIPTION
1	873731000	Nut, Keps #10-24 UNC	19	532109228	Lever, Lock, Handle
2	532009266	Grip, Handle	20	532009484	Clip
3	872140404	Bolt, Carriage 1/4-20	21	532086777	Screw, Hex Washer Hd. Slotted #10-24 x 1/2
4	871091008	Screw, Truss Hd. #10-24 UNC x 1/2	22	532102604	Grip, Bar, Control
7	532126956	Panel, Control	23	810040400	Washer, Lock 1/4
8	532104164	Tie, Cable	24	873220400	Nut, Hex 1/4-20
9	532124797	Grip, Handle	25	532102744	Clamp, Bar, Control
10	532109335	Handle, Shift	26	532105216	Bar Assembly, Control
11	532124788	Clip, Hairpin	27	532102162	Cable, Clutch
12	532081328	Bolt, Shoulder	29	532125011	Handle
13	532109313	Grommet, Rubber	30	532127012	Control, Throttle
14	532109337	Rod, Shift	--	532127605	Manual, Owner's (English)
15	872110608	Bolt, Carriage 3/8-16 x 1 Gr. 5	--	532127606	Manual, Owner's (French)
16	532109229	Lock, Handle	--	532127607	Manual, Parts (English)
17	532005394	Nut 3/8-16	--	532127608	Manual, Parts (French)
18	819131611	Washer 13/32 x 1 x 11 Ga.	--	532126951	Decal, Instruction
			--	532124624	Decal, Control Panel
			--	532110614	Decal, Hand Placement

NOTE: All component dimensions given in U.S. inches.
 1 inch = 25.4 mm

5 HP 17" CRT TILLER -- MODEL NUMBER CRT50

MAINFRAME, LEFT SIDE

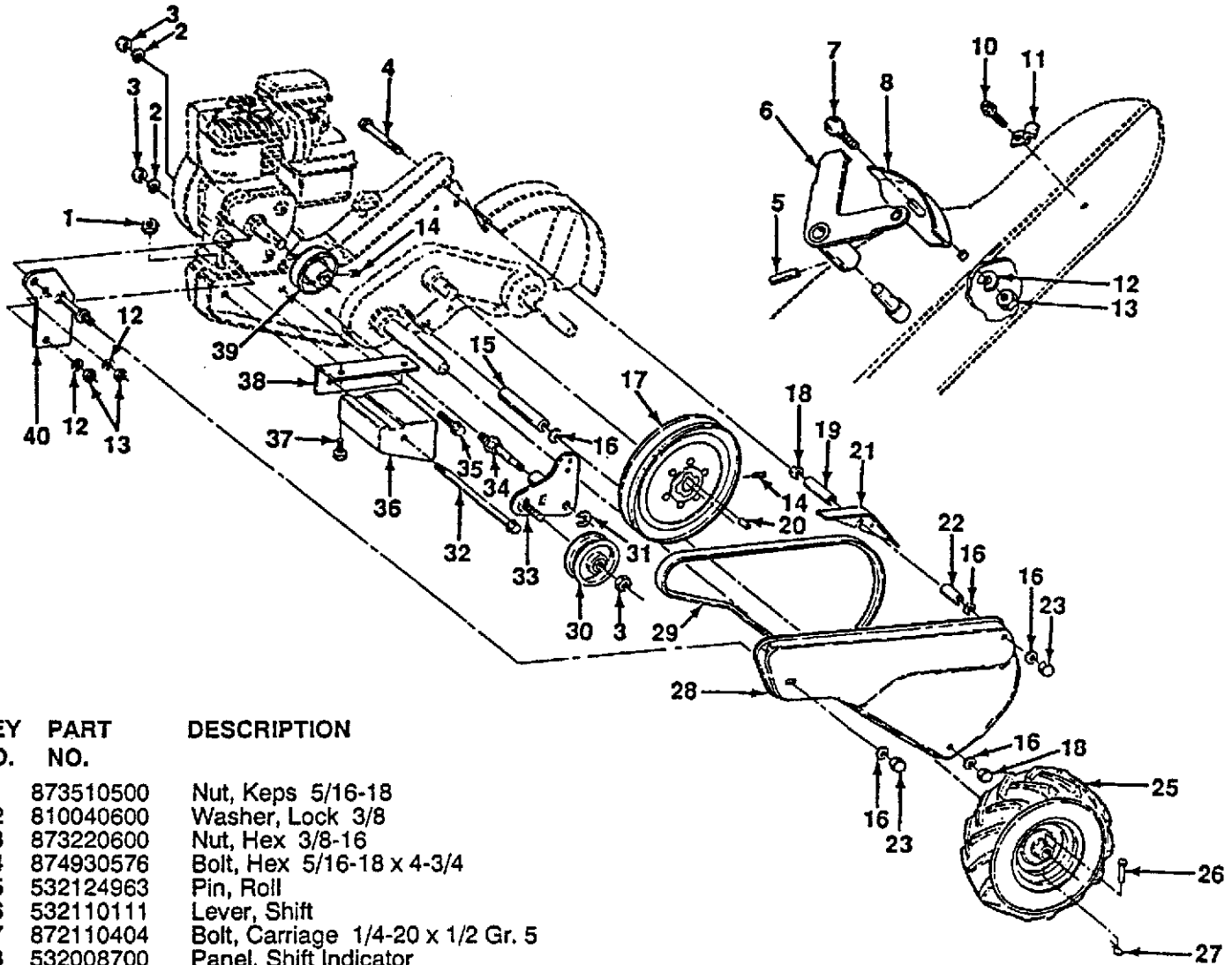

KEY NO.	PART NO.	DESCRIPTION
1	873510500	Nut, Keps 5/16-18
2	810040600	Washer, Lock 3/8
3	873220600	Nut, Hex 3/8-16
4	874930576	Bolt, Hex 5/16-18 x 4-3/4
5	532124963	Pin, Roll
6	532110111	Lever, Shift
7	872110404	Bolt, Carriage 1/4-20 x 1/2 Gr. 5
8	532008700	Panel, Shift Indicator
10	532086777	Screw, Hex, Washer Head, Slotted #10-24 x 1/2
11	532009484	Clip
12	810040400	Washer, Lock 1/4
13	873220400	Nut, Hex 1/4-20
14	823230506	Screw, Set Hex 5/16-18 x 3/8
15	532120938	Spacer, Split 0.327 x 0.42 x 2.68
16	819111116	Washer 11/32 x 11/16 x 16 Ga.
17	532100473	Sheave, Transmission
18	873220500	Nut, Hex 5/16-18
19	532110651	Spacer, Split 0.327 x 0.42 x 1.75
20	532002649	Key, Square 3/16 x 1-1/8
21	532110653	Guard, Pinch Point
22	532110652	Spacer, Split 0.327 x 0.42 x 2.09
23	532104214	Nut, Cap 5/16-18
25	532102190	Tire
	532124258	Rim
	532124718	Tire Valve
26	532126875	Rivet, Drilled
7	532124788	Clip, Hairpin

KEY NO.	PART NO.	DESCRIPTION
28	532125091	Guard, Belt
29	532102143	Belt, V
30	532104679	Pulley, Idler
31	812000032	Ring, Klip
32	532102384	Bolt, Hex 5/16-16 x 12
33	532105611	Bracket, Idler
34	532102141	Shaft, Idler Arm
35	874760616	Bolt, Hex 3/8-16 x 1
36	532102383	Counterweight, L. H.
37	874760524	Bolt, Hex 5/16-18 x 1-1/2
38	532102331	Bracket, Reinforcement, L. H.
39	532102142	Sheave, Engine
40	532102376	Bracket, Guard Belt
--	532104323	Decal, Shift Indicator
--	532124265	Decal, Belt Guard

NOTE: All component dimensions given in U.S. inches.
 1 inch = 25.4 mm

REPAIR PARTS

5 HP 17" CRT TILLER -- MODEL NUMBER CRT50

MAINFRAME, RIGHT SIDE

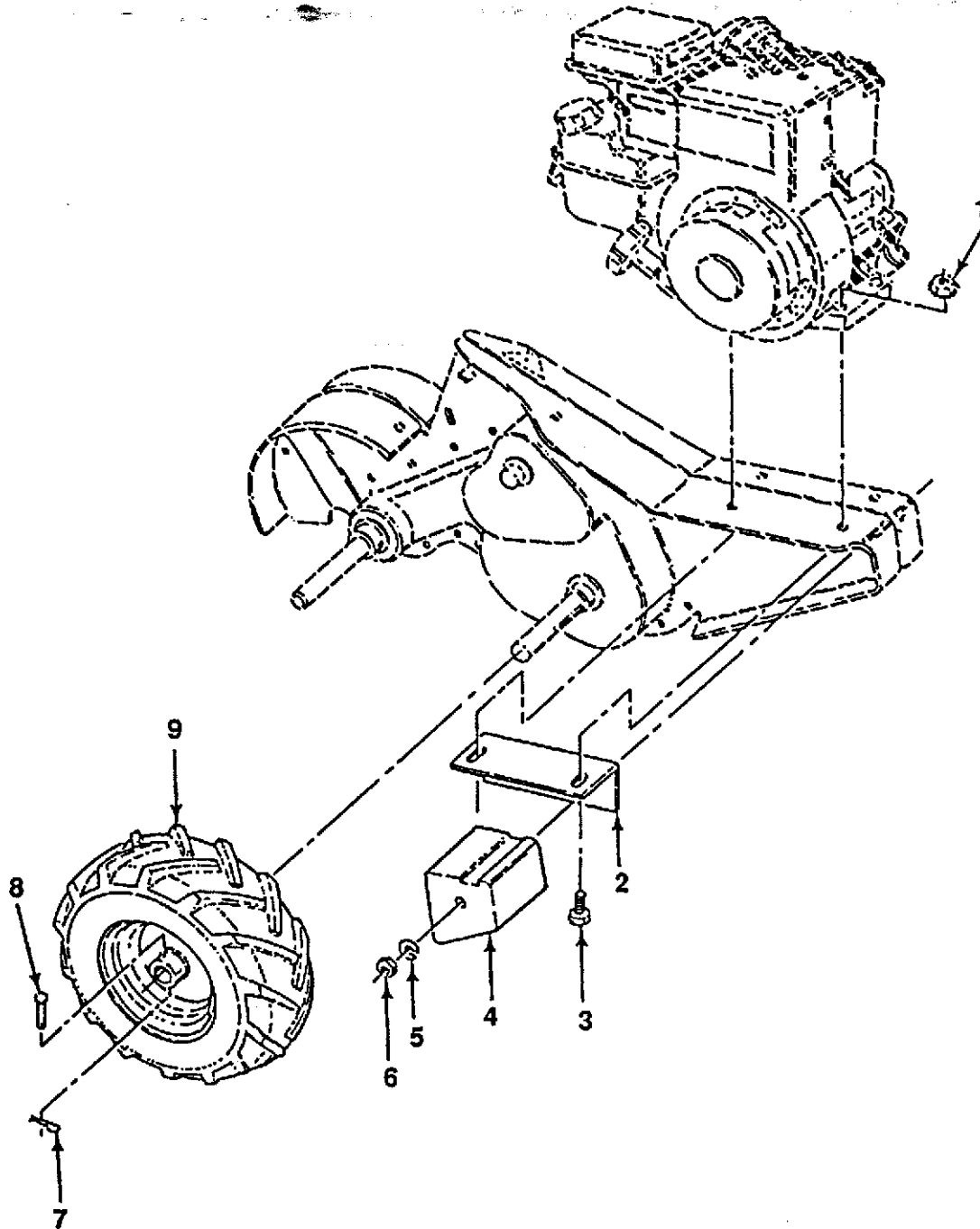

KEY NO.	PART NO.	DESCRIPTION
1	873510500	Nut, Keps 5/16-18
2	532102332	Bracket, Reinforcement
3	874760524	Bolt, Hex 5/16-18 x 1-1/2
4	532102173	Counter Weight, R.H.
5	810040600	Washer, Lock 3/8
6	873220600	Nut, Hex 3/8-16
	532124788	Clip, Hairpin

KEY NO.	PART NO.	DESCRIPTION
8	532126875	Rivet, Drilled
9	532102190	Tire
	532124258	Rim
	532124718	Tire Valve
--	532121543	Decal, Engine
--	532110612	Decal, Caution (Engine)
--		Decal, OPEI

NOTE: All component dimensions given in U.S. inches.
1 inch = 25.4 mm

REPAIR PARTS

5 HP 17" CRT TILLER -- MODEL NUMBER CRT50

TRANSMISSION

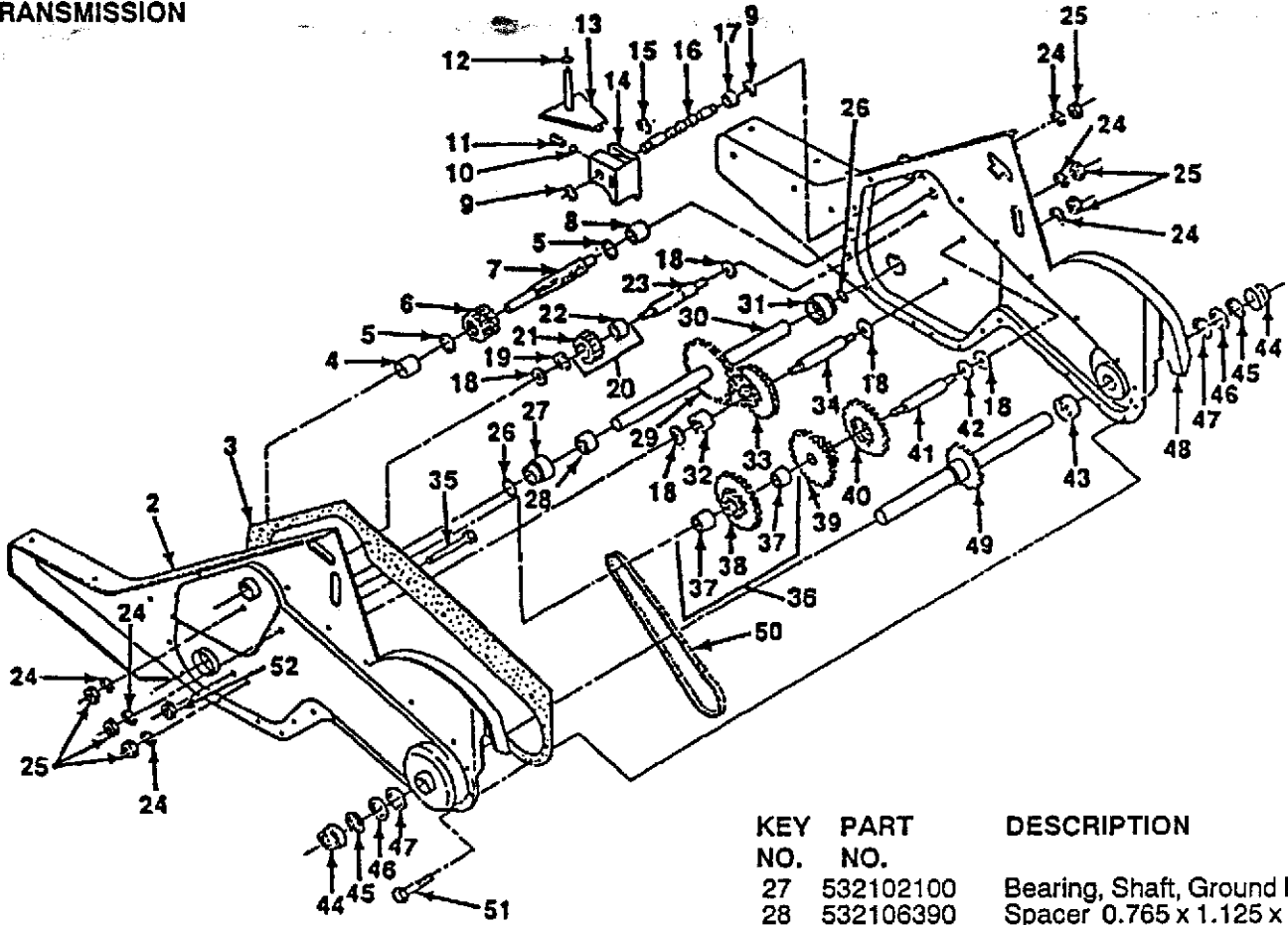

KEY NO.	PART NO.	DESCRIPTION
--	532121146	Transmission Assembly (Includes Key Nos. 2-52)
2	532121147	Gearcase, L.H. w/Bearing (Includes Key No. 4)
3	532106211	Gasket, Gearcase
4	532005020	Bearing, Needle
5	532001370	Washer, Thrust 5/8 x 1.10 x 1/32
6	532102113	Pinion, Input
7	532102110	Shaft, Input
8	532124792	Bearing, Needle
9	532102136	Washer, Seal
10	532124697	Ball, Steel
11	532100371	Spring, Shift, Fork
12	532106160	O-Ring
13	532102107	Arm, Shift
14	532008353	Fork, Shift
15	120000039	Ring, Klip <i>should be 812000039</i>
16	532102109	Shaft, Shift
17	532104159	Spacer, Split
18	532004358	Washer
19	812000040	Ring, Klip
20	532102114	Gear, Assembly, Reverse Idler (Includes Key Nos. 21 and 22)
21	532102115	Gear, Reverse Idler
22	532006803	Bearing, Needle
23	532102111	Shaft, Reverse Idler
24	810040700	Washer, Lock 7/16
25	873610700	Nut, Hex 7/16-20
26	532102128	O-Ring

KEY NO.	PART NO.	DESCRIPTION
27	532102100	Bearing, Shaft, Ground Drive
28	532106390	Spacer 0.765 x 1.125 x 1.23
29	532102134	Chain #35-50 Pitch
30	532109204	Ground Shaft Assembly
31	532102106	Bearing, Shaft, Ground Drive
32	532106388	Spacer 0.70 x 1.00 x 1.150
33	532102121	Sprocket and Gear Assembly
34	532102112	Shaft, Reduction (2nd)
35	532102101	Screw, Whiz, Lock 5/16-18 x 3-1/2
36	532106141	Sprocket Assembly w/Bearing (Includes Key Nos. 37 and 38)
37	532124791	Bearing, Needle
38	532106142	Sprocket, Tine
39	532105345	Gear, Cluster, Red 1st & 2nd
40	532105346	Gear, Reverse
41	532008358	Shaft, Reduction (1st)
42	532004220	Washer, Thrust
43	532106146	Spacer 1.01 x 1.75 x 0.760
44	532009672	Cup, Formed
45	532102144	Ring, Spiral
46	532009676	Seal, Ring, Rubber
47	532009674	Seal, Oil
48	532121745	Gearcase, R.H. w/Bearing (Includes Key No. 8)
49	532106144	Shaft, Tine
50	532106147	Chain, Roller #50-50 Pitch
51	817580408	Screw 1/4-20 x 1/2
52	873220500	Nut, Hex 5/16-18
--	532006066	Grease, Plastilube #1

NOTE: All component dimensions given in U.S. inches.
1 inch = 25.4 mm

REPAIR PARTS

5 HP 17" CRT TILLER -- MODEL NUMBER CRT50

TINE SHIELD

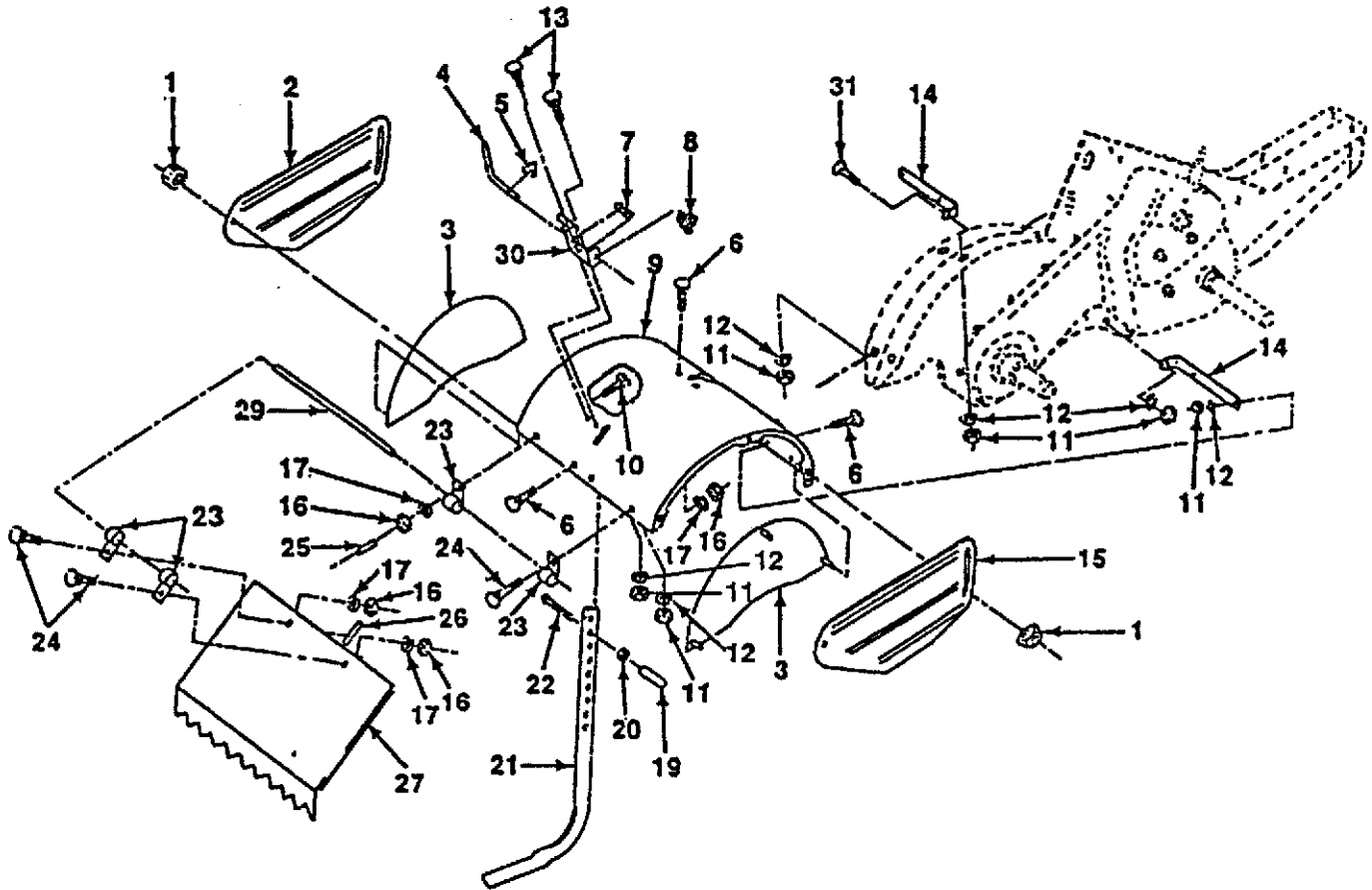

KEY NO.	PART NO.	DESCRIPTION
1	898000129	Nut, Flange 5/16-18
2	532125012	Shield, Side outer L. H.
3	532125013	Shield, Side
4	532008393	Pin, Stake Depth
5	812000036	Ring, Klip
6	872140506	Bolt, Carriage 5/16-18 x 3/4 Gr 5
7	532008394	Spring
8	532109230	Spring, Depth Stake
9	532125014	Shield, Tine
10	872040410	Bolt, Carriage 1/4-20 x 1-1/4 Gr. 5
11	873220500	Nut, Hex 5/16-18
12	810040500	Washer, Lock 5/16
13	872110508	Bolt, Carriage 5/16-18 x 1
14	532124343	Bracket, Shield Tine
15	532125015	Shield, Side Outer R.H.
16	873220400	Nut, Hex 1/4-20
17	810040400	Washer, Lock 1/4

KEY NO.	PART NO.	DESCRIPTION
19	532102701	Grip
20	873220600	Nut, Hex 3/8-16
21	532102156	Stake, Depth
22	874930632	Bolt, Hex 3/8-16 x 2
23	532004440	Hinge
24	872140404	Bolt, Carriage 1/4-20 x 1/2 Gr. 5
25	532124717	Cap, Vinyl
26	532109227	Pad, Idler
27	532125016	Shield, Leveling
29	532120588	Pin, Hinge
30	532008392	Bracket, Latch
31	872110510	Bolt, Carriage 5/16-18 x 1-1/4
--	532124263	Decal, Tine Shield
--	532120076	Decal, Warning (Leveling Shield)

NOTE: All component dimensions given in U.S. inches.
1 inch = 25.4 mm

REPAIR PARTS

5 HP 17" CRT TILLER -- MODEL NUMBER CRT50

TINES

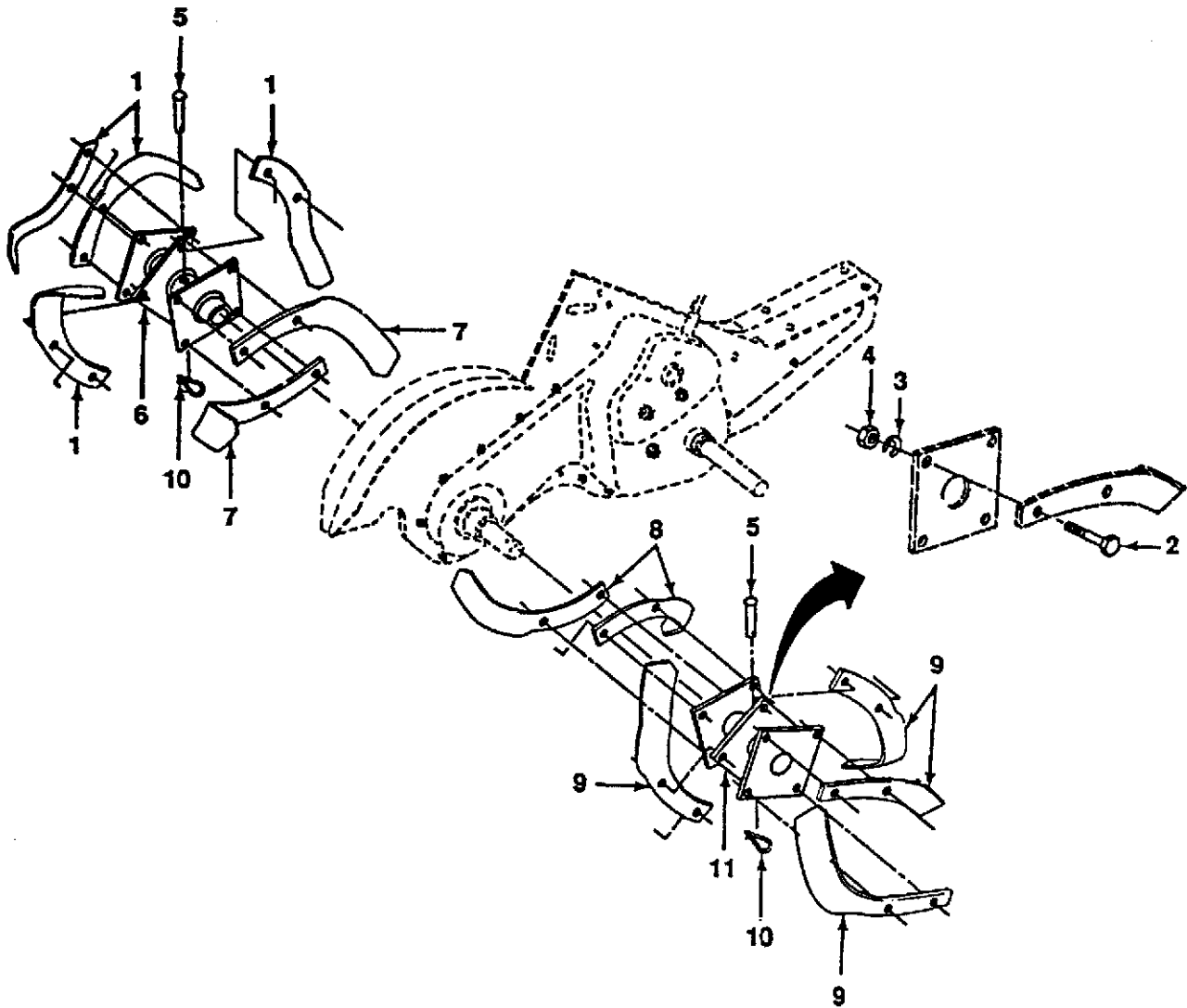

KEY PART NO.	PART NO.	DESCRIPTION
1	532004459	Tine, L. H. Outer
2	874610616	Bolt, Hex 3/8-24 x 1
3	810040600	Washer, Lock 3/8
4	873610600	Nut, Hex 3/8-24
5	532004929	Clevis Pin
6	532102380	Assembly, Hub and Plate, L. H.

KEY PART NO.	PART NO.	DESCRIPTION
7	532006554	Tine, L. H. Inner
8	532006555	Tine, R. H. Inner
9	532004460	Tine, R. H. Outer
10	532124660	Clip, Hairpin
11	532102382	Assembly, Hub and Plate, R. H.

NOTE: All component dimensions given in U.S. inches.
1 inch = 25.4 mm