

200 Chain Saw UT-10690
Carburetor

Page 2 of 12

Ref #	Part Number	Qty	S/P/F	Description
1	02768	1		Repair Kit
	02773	1		Oil Pump Plunger Kit
2	02768	1		Repair Kit
	02773	1		Oil Pump Plunger Kit
3	02768	1		Repair Kit
	02769	1	S	Gasket/Diaphragm Kit
4	02768	1		Repair Kit
	02769	1	S	Gasket/Diaphragm Kit
5	02768	1		Repair Kit
	02769	1	S	Gasket/Diaphragm Kit
6	02768	1		Repair Kit
	02769	1	S	Gasket/Diaphragm Kit
7	02768	1		Repair Kit
8	02768	1		Repair Kit
9	02768	1		Repair Kit
10	02768	1		Repair Kit
11	02768	1		Repair Kit
12	02768	1		Repair Kit
13	02768	1		Repair Kit
14	02768	1		Repair Kit
15	02768	1		Repair Kit
16	02768	1		Repair Kit
17	02768	1		Repair Kit
18	02768	1		Repair Kit
19	02768	1		Repair Kit
20	02768	1		Repair Kit
21	02768	1		Repair Kit
22	02768	1		Repair Kit
23	02768	1		Repair Kit
24	02770	1		Oil Pump Body

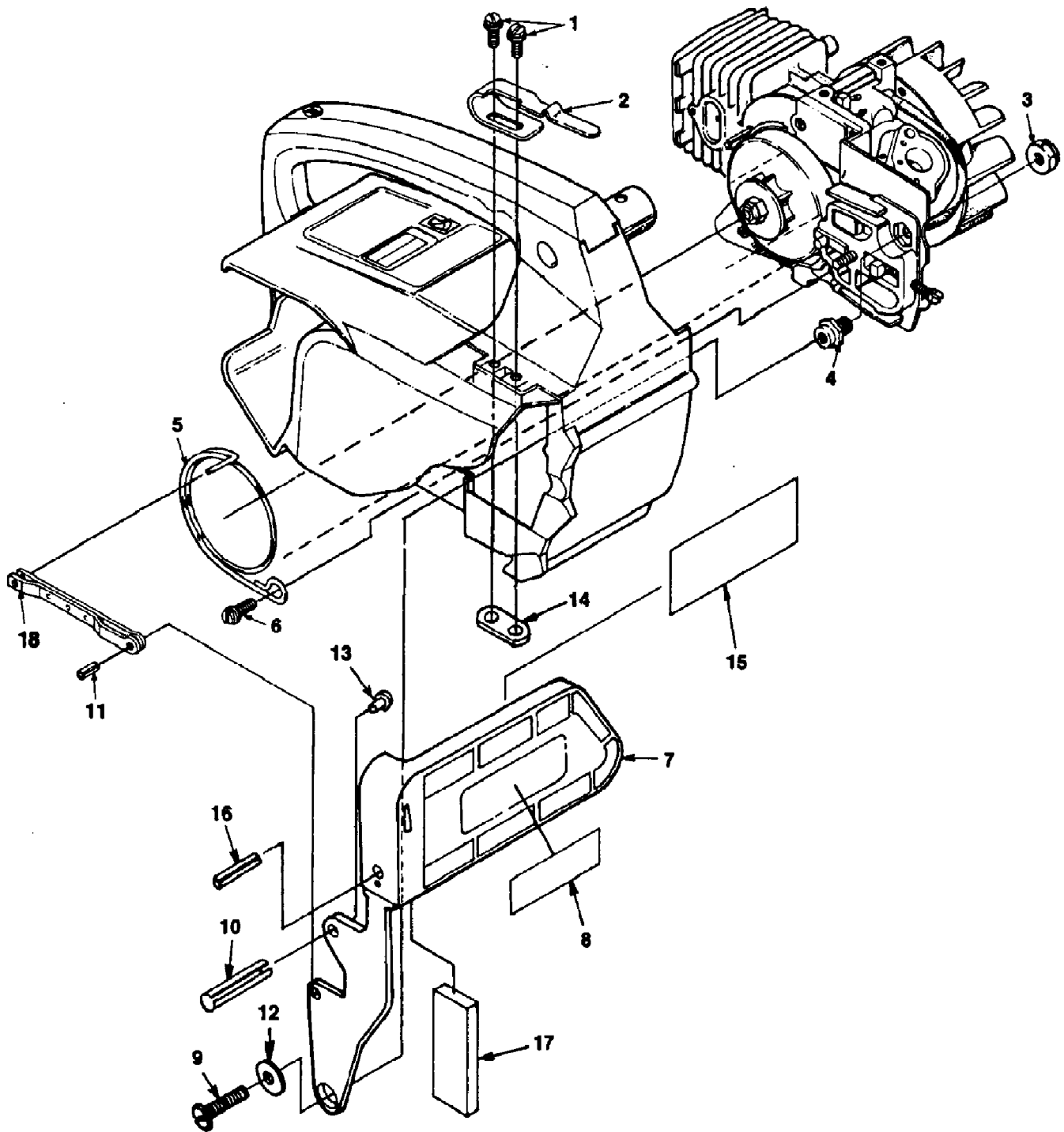

200 Chain Saw UT-10690
Chain Brake

Page 4 of 12

Ref #	Part Number	Qty	S/P/F	Description
1	88066	2	S	SCREW- Hex hd. w/washer (8-32 x 1/2")
2	02635	1		CLIP- Retaining
3	81124A	1	/P	NUT- Hex
4	70636	1		POST- Chain brake
5	70637B	1		BAND- Brake
6	82579	1		SCREW- Torx (10-24 x 5/8")
7	A03061	1		HANDGUARD & LEVER
8	02661	1		DECAL (International Only)
9	82166	1		SCREW- (10-32 x 1/2")
10	JA461383	1		PIN- Roll (3/16 x 1")
11	95395A	1	/P	PIN- Spring
12	70632	1	/P	WASHER- Flat
13	82367	1	/P	SCREW- Drive
14	02637	1		NUT- Weld
15	02661	1		DECAL- Handguard
16	JA461361	1		PIN- Roll (1/8 x 7/8") (International Only)
17	02462	1		WEIGHT (International Only)
18	A70767	1		PIVOT- Link

200 Chain Saw UT-10690
Engine Internals

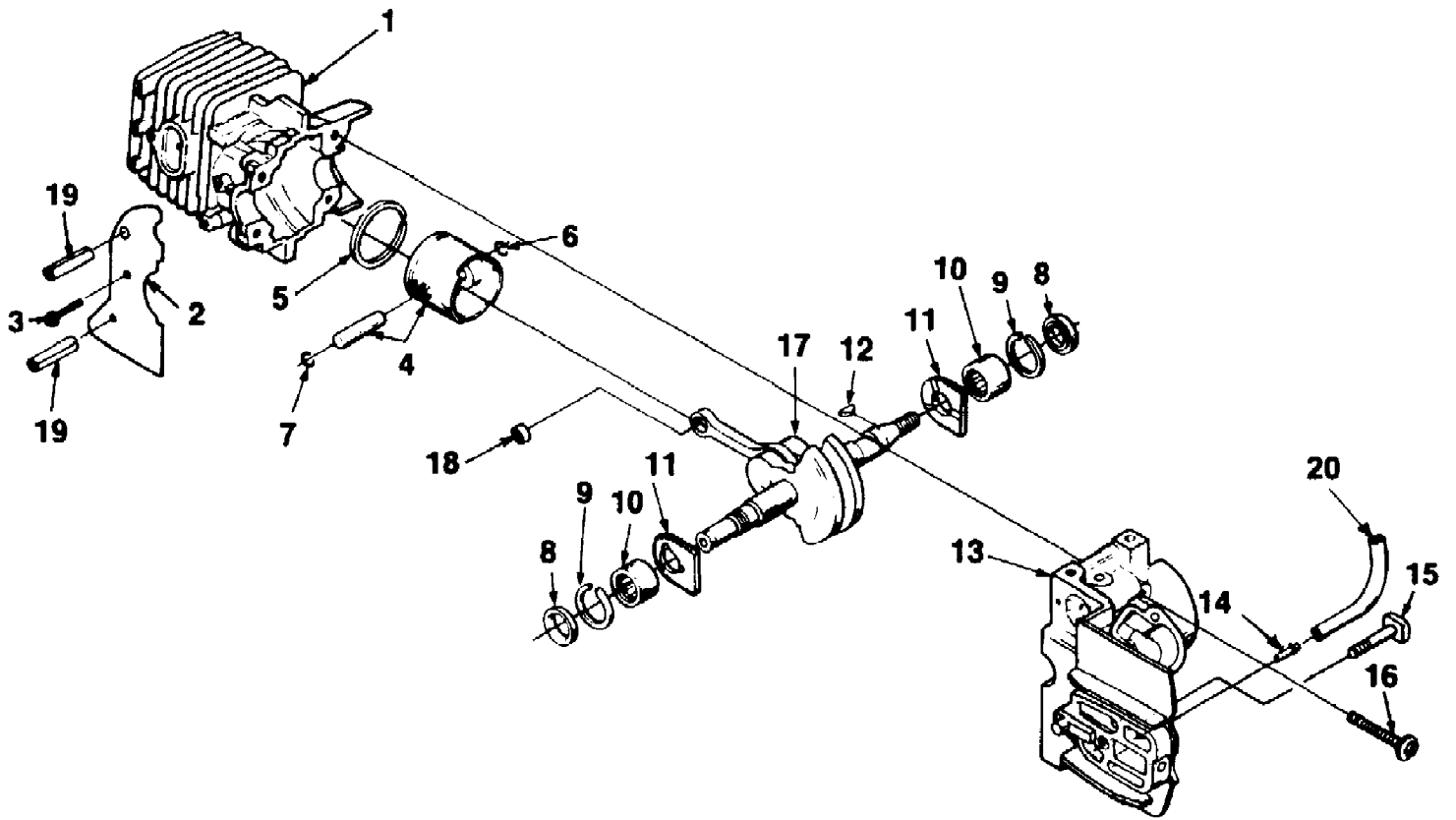

200 Chain Saw UT-10690
Engine Internals

Page 6 of 12

Ref #	Part Number	Qty	S/P/F	Description
1	024852	1	S	CYLINDER
2	02639	1	/P	SHIELD- Sawdust
3	93932	1		SCREW- Tapping (36-32 x 5/16")
4	A98967A	1	S	PISTON & PIN ASSY.
5	93165	1		RING- Piston
6	65261	1	/P	RING- Retaining
7	98096	1		RING- Retaining
8	94638	2	S	SEAL
9	69407	2	S	SPACER
10	12530	2		BEARING- Needle
11	02464	2		WASHER- Thrust
12	69250	1	/P	KEY
13	A03060	1		CRANKCASE ASSY.
14	94619	1		FITTING
15	69195	1	/P	BOLT- Guide bar, thd. forming
16	82567	4		SCREW- Torx pan hd. (10-24 x 1 1/8")
17	A03059	1		CRANKSHAFT ASSY.
18	02035	1	/P	BEARING
19	70763	2	/P	PIN- Roll (5/32 x 1 1/8")(Brake Mod. Only)
20	7030917	1		TUBING- Rubber (Oil line) (4 1/4")

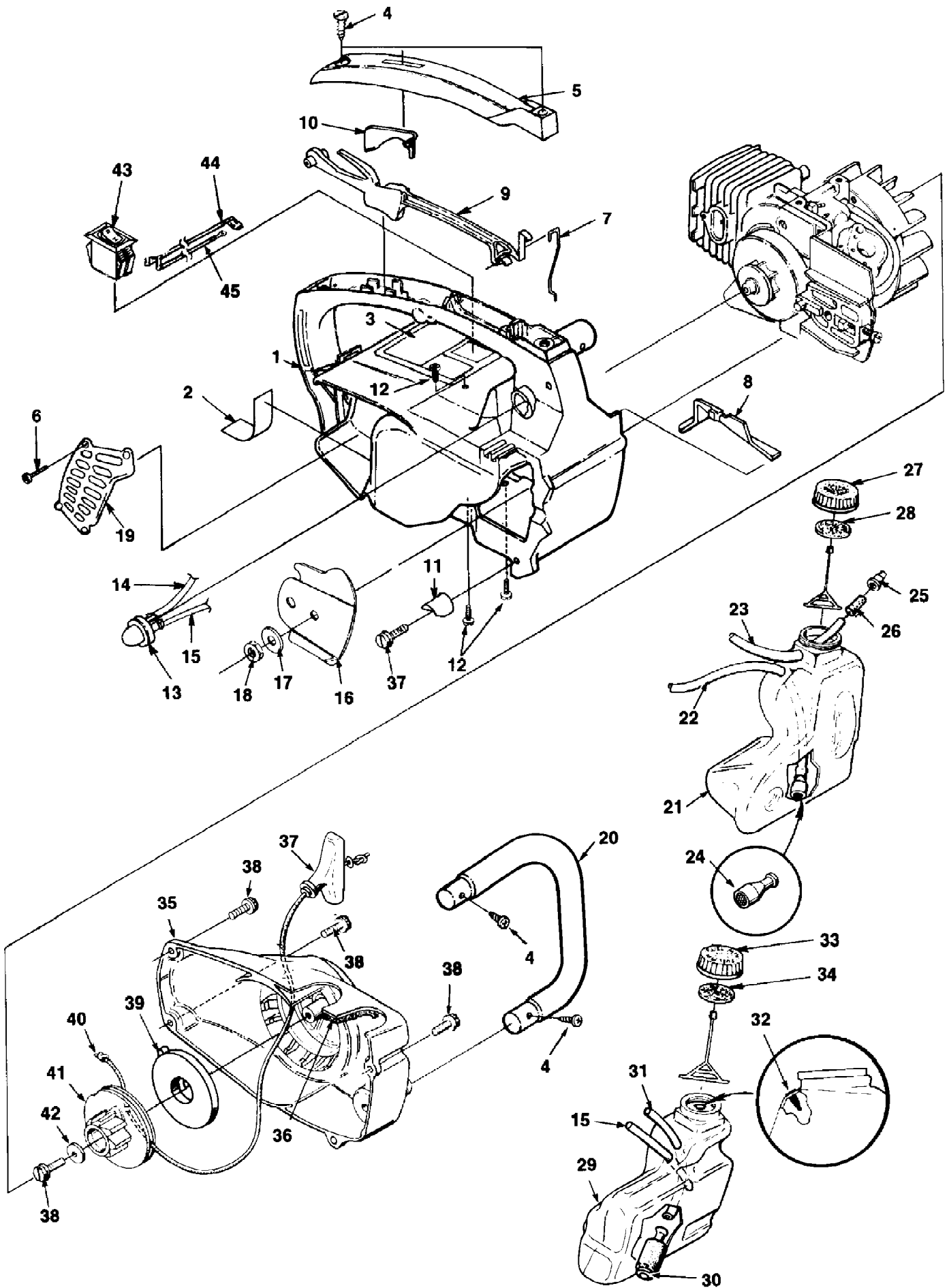

200 Chain Saw UT-10690
Exploded View

Page 8 of 12

Ref #	Part Number	Qty	S/P/F	Description
1	A03058	1	/P	HOUSING- Engine
2	02640	1		TAPE
3	02490	1		DECAL
	03271	1		DECAL (International Only)
4	94065	4		SCREW- Pan, plastite (#10-16 x 3/4")
5	02495	1		COVER- Handle
6	82528	4	/P	SCREW- Pan plastite (#6-3/8")
7	02501	1	/P	ROD- Throttle
8	02481	1		COVER- Air filter
9	02492A	1		TRIGGER
10	02493	1		LOCK- Trigger
11	95212	1	/P	STOP- Chain
12	82538	4	/P	SCREW- Torx, taptite (#10-24 x 3/4")
13	02487	1	/P	PRIMER BULB
14	0143912	1	S/P	TUBING- Inlet (3")
15	7031030	1	S	TUBING- Return (7")
16	69360A	1		PLATE- Guide bar
17	69309A	1	/P	WASHER- Flat
18	810652	1	S	NUT- Hex
19	02765	1		SHIELD- Muffler
20	02496	1	S	HANDLE BAR
21	A02763	1	S	TANK- Oil
22	7031036	1	S	TUBING- (9")
23	7031019	1	S	TUBING (4 3/4")
24	A68593	1		FINDER- Oil
25	98819	1	/P	VALVE- Check
26	01327	1	/P	FITTING- Oil line
27	A97230A	1		CAP-Oil
28	94494	1	/P	GASKET- Cap
29	A02764	1		TANK- Fuel
30	49422	1	S	FILTER- Fuel
31	7031022	1	S	LINE- Fuel (5 1/2")
32	98819	1	/P	VALVE- Check
33	A97230A	1		CAP- Fuel
34	94494	1	/P	GASKET- Cap
35	A02562B	1	S	STARTER HOUSING ASSY.
36	69443	1		FILTER
37	02264	1	S	GRIP- Starter
38	82563	6	/P	SCREW- Torx, plastite (#10 x 3/4")
39	A97908	1	/P	SPRING & CONTAINER
40	9789901	1	/P	ROPE- Starter
41	97768A	1		PULLEY- Starter
42	94062	1	/P	WASHER- Retaining
43	02497	1	S/P	SWITCH
44	A02482	1	S	LEAD- w/Flag Term.
45	A02484	1		LEAD- w/Ring Term.

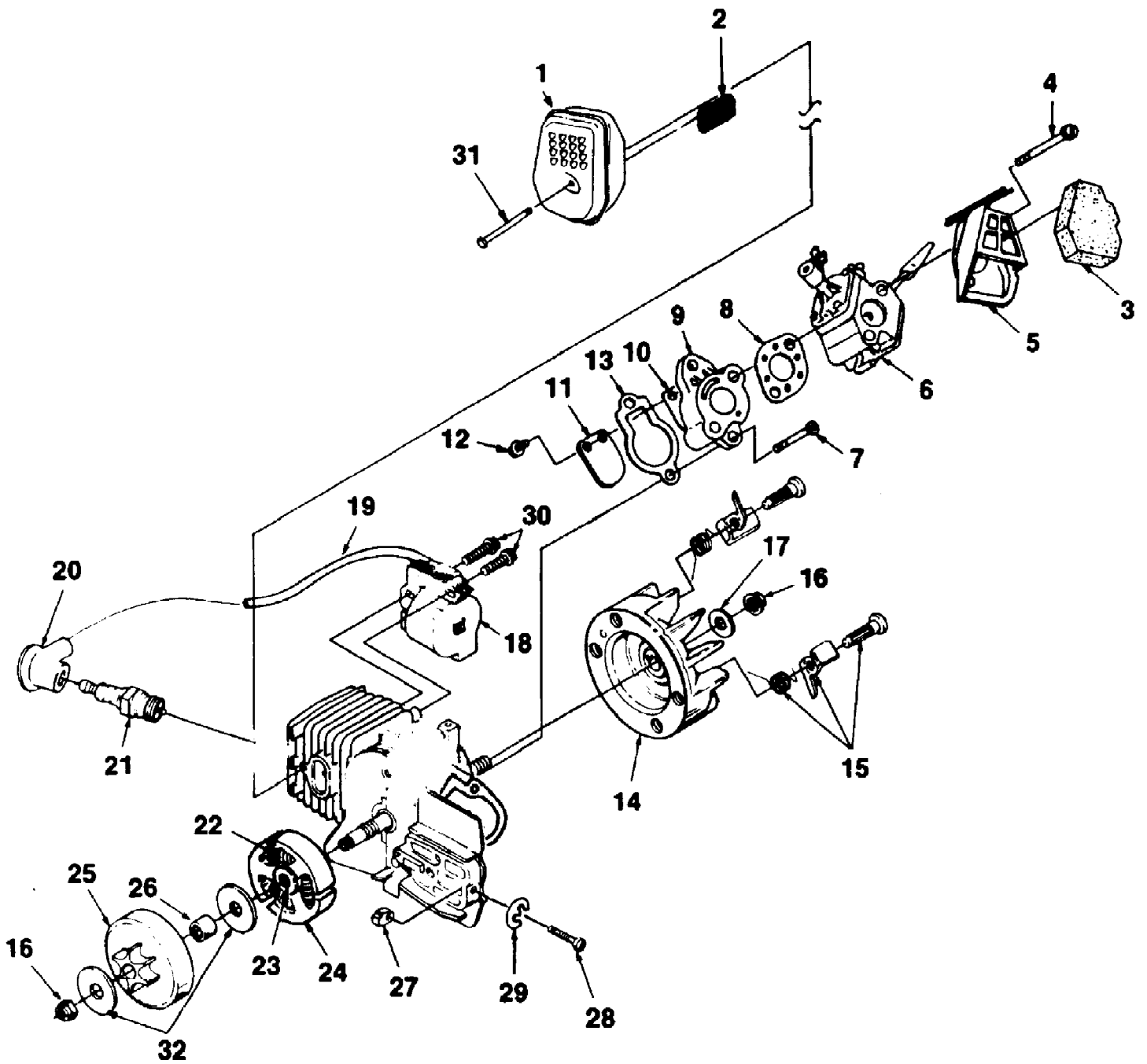

200 Chain Saw UT-10690
Peripheral Engine Parts

Page 10 of 12

Ref #	Part Number	Qty	S/P/F	Description
1	A02459	1		MUFFLER
2	02458	1		SCREEN- Spark arrestor
3	02500	1	S	FILTER- Air
4	82578	2	S	SCREW- Shoulder plastite (#10-24 x 1 3/4")
5	02491	1		BOX- Air filter
6	A02486	1		CARBURETOR & OIL PUMP ASSY.
7	82549	2		SCREW- Torx taptite, thd. forming (10-24 x 1")
8	02488	1	S	GASKET- Carburetor
9	A02499	1		HEAT DAM
10	95983	1	S	REED
11	03205	1		STOP- Reed
12	82498	2	/P	SCREW- Hex Taptite (4-40 x 3/8")
13	02453	1	/P	GASKET- Intake manifold
14	A95007	1	S	ROTOR & STARTER PAWL
15	A70285E	1	/P	KIT- Starter pawl
16	81229	2		NUT- (5/16-24)
17	84065	1	S	WASHER- (5/16")
18	94711BS	1	S	MODULE
19	69326	1		LEAD- Hi-Tension
20	A33055	1	/P	TERMINAL
21	96169S	1	S	SPARK PLUG (Champion DJ7Y)
	79252	1	S	SPARK PLUG (Champion RDJ7Y) (International Only)
22	98066	3		SPRING- Clutch
23	79221	1	/P	SPIDER- Clutch
24	79222A	3		SHOE- Clutch
25	A95653C	1	S	SPROCKET & DRUM
26	70277	1	S	BEARING
27	692542	1	/P	PIN- Adjusting
28	A00440	1	/P	SCREW & E-RING KIT
29	93574	1	S	E-RING
30	82248	2		SCREW- Machine hex sems (#8-32 x 3/4")
31	93460	1	/P	SCREW- Machine hex sems (10-24 x 1 7/8")
32	95299	2	/P	WASHER- Thrust

**ACCESSORIES
ACCESSOIRES
TUBEHÖR
ACCESSORIES
ACCESORIOS**

- KIT- Repair (sprocket nose bar)..... A-70239-E**
 Jeu de réparation (Lame à nez à pignon)
 Reparatursatz (Kettenrad-Nasenspitze)
 Kit per riparazioni (denta punta lama)
 Juego de reparación (extremo barra rueda dentada)
- FUEL LINE (10 ft. length) 70310-99**
 Conduite de carburant (3 m de long)
 Kraftstoffleitung (3 m Länge)
 Condotto d'alimentazione (3 m di lunghezza)
 Línea de combustible (10 pies de largo)
- OIL LINE- (10 ft length)..... 70309-99**
 Conduite d'huile (3 m de long)
 Ölleitung (3 m Länge)
 Condotto dell'olio (3 m di lunghezza)
 Línea de aceite (10 pies de largo)
- SAFE•T•TIP® (Standard) DA-70776-B**
 SAFE•T•TIP® (Standard)
 SAFE•T•TIP® (Standard)
 SAFE•T•TIP® (Standard)
 SAFE•T•TIP® (Standard)
- GREASE- Multi Purpose (Sprocket 18453**
 bearing-PT guide bar)
 Graisse universelle (Palier de pignon-PT - lame-guide)
 Mehrzweck-Schmiermittel (Kettenradlager-PT-Führungsschiene)
 Grasso, multuso Cuscinetto della ruota dentata - PT - barra di guida)
 Grasa de uso general (Cojinete de la rueda dentada - PT - barra guía)
- CARRYING CASE 94215-A**
 Boítier de transport
 Tragekasten
 Custodia
 Maletín
- STARTING ROPE (250 ft. Reel)..... 98052-A**
 Cordon de lanceur (75 m bobine)
 Startersell (76 m Spule)
 Corda d'avviamento (bobina da 76 m)
 Cuerda de arranque (carrete de 76 m)

**TOOLS
OUTILS
WERKZEUGE
ATTREZZI
HERRAMIENTAS**

- WRENCH (combination).....D-24814-A**
 Clé combiné
 Schraubenschlüssel Kombination
 Chiave combinata
 Llave combinada
- SILASTIC (crankcase sealing)..... 24823**
 Silastic (étanchéité du carter)
 Silastic (Kurbelgehäuse Dichtung)
 Silastic (sigillo di tenuta del carter)
 Silastic (sello del cárter)
- PULLER- Magneto Rotor..... A-24747-A**
 Extracteur, rotor magnéto
 Abziehwerkzeug-Magnetrotor
 Rotore d'estrazione a magnete
 Extractor-rotor de magneto
- IGNITION TEST SPARK PLUG JA-31316-4**
 Testeur d'allumage
 Testzündkerze für Zündprüfung
 Candela di collaudo
 Bujía para probar el encendido
- SHIM (0.015" AIR GAP).....22486**
 Cale (écart de 0,38 mm)
 Distanzscheibe (0,38 mm Luftspalt)
 Spessore (spinterometro 0,38 mm)
 Suplemento (espacio de 0,38 mm)
- T-25 TORX DRIVE BIT 24982-01**
 Foret torx T-25
 T-25 Torx-Antriebsbit
 Punta Torx Drive T-25
 Broca de empuje T-25 Torx
- T-27 TORX DRIVE BIT 18566-01**
 Foret torx T-27
 T-27 Torx-Antriebsbit
 Punta Torx Drive T-27
 Broca de empuje T-27 Torx

200 Chain Saw UT-10690
Tools & Accessories

Page 12 of 12

Ref #	Part Number	Qty	S/P/F	Description
A-70239-E	A70239E	1		KIT- Repair (sprocket nose bar)
7031099	7031099	1	S	FUEL LINE (10 ft. length)
7030999	7030999	1	/P	OIL LINE- (10 ft. length)
DA-70776-B	DA70776B	1		SAFE-T-TIP (Standard)
18453	18453	1	/P	GREASE- Multi Purpose (Sprocket bearing-PT guide bar)
94215-A	94215A	1		CARRYING CASE
98052-A	98052A	1	/P	STARTING ROPE (250 ft. Reel)
D-24814-A	D24814A	1		WRENCH (combination)
24823	24823	1	S	SILASTIC (crankcase sealing)
A24747A	A24747A	1		PULLER- Magneto Rotor
JA313164	JA313164	1		IGNITION TEST SPARK PLUG
22486	22486	1		SHIM (0.015" AIR GAP)
2498201	2498201	1		T-25 TORX DRIVE BIT
18566-01	1856601	1	/P	T-27 TORX DRIVE BIT