



M216KA
M216KASP

For Serial Nos.
220,000 & Higher



OPERATOR'S MANUAL

METROTM 21

ZONE START MODELS

CONGRATULATIONS on the purchase of your new Exmark mower. This product has been carefully designed and manufactured to give you a maximum amount of dependability and years of trouble-free operation.

If additional information is needed, or should you require trained mechanic service, contact your authorized Exmark equipment dealer or distributor.

If you need to order replacement parts from your dealer, always give the model number and serial number of your mower as well as the part number, description and quantity of the part needed.

The Serial No. plate is located on the top of the mower deck on the right hand rear corner.

For ease of ordering and reference, we suggest that you record the information requested in the following identification table.

Model No.	_____
Serial No.	_____
Engine Model No.	_____
Engine Serial No.	_____
Date Purchased	_____

Paste Label From
Literature Packet Here

IMPORTANT

When the mower is used or operated on any California forest-, brush- or grass-covered land, a working spark arrester must be attached to the muffler. If not, the operator is violating state law, Section 4442 Public Resource Code. To acquire a spark arrester for your unit, see you Engine Service Dealer.



WARNING



POTENTIAL HAZARD

- This product is a powerful machine.

WHAT CAN HAPPEN

- Failure to follow safe operating practices can result in serious operator injury or even death.

HOW TO AVOID THE HAZARD

- Keep all shields, guards, and safety devices (especially the grass discharge system) in place and in proper working condition.
- Stop engine and remove spark plug wire(s) or remove key and wait for all moving parts to stop before adjusting, servicing, or performing maintenance.
- If mower deck becomes clogged, stop engine and remove spark plug wire(s) or remove key and wait for all moving parts to stop before cleaning blockage.
- Keep hands, feet, and clothing away from power driven parts.
- Keep off mower unless seat platform is provided.
- Keep others off mower.



WARNING



POTENTIAL HAZARD

- Gasoline is harmful or fatal if swallowed. Long-term exposure to vapors has caused cancer in laboratory animals.

WHAT CAN HAPPEN

- Failure to use caution may cause serious injury or illness.

HOW TO AVOID THE HAZARD

- Avoid prolonged breathing of vapors.
- Keep face away from nozzle and gasoline tank/container opening.
- Keep gasoline away from eyes and skin.
- Never siphon gasoline by mouth.

Exmark reserves the right to make changes to add improvements to its products at any time without incurring any obligation to make such changes to products manufactured previously. Exmark, or its distributors and dealers, accept no responsibility for variations which may be evident in the actual specifications of its products and the statements and descriptions contained in this publication.

EXMARK PARTS PLUS® PROGRAM

EFFECTIVE DATE: September 1, 1995

Program

If your Exmark dealer does not have the Exmark part in stock, Exmark will get the parts to the dealer the next business day or the part will be FREE* Guaranteed!!

How the Program Works

1. If dealer does not have part in stock for a "down" unit at the time of request by customer, the dealer contacts his distributor by 1:00 p.m. local time, and requests Exmark Parts Plus® shipment of six line items or less.
2. Distributor ships part(s) to dealer or customer, as requested by dealer, same day, overnight UPS. Distributor bills dealer for part and freight charges where applicable.
3. If distributor does not have the part(s) in stock to satisfy Exmark Parts Plus® order, he contacts Exmark by 3:00 p.m., central time, with an Exmark Parts Plus® order of six line items or less.
4. If order is received by 3:00 p.m. central time, Exmark ships part(s) direct to dealer or customer, as requested by distributor, same day, overnight UPS, Exmark bills the distributor for parts and shipping charges, where applicable.
5. The customer pays for the part and freight if it is shipped under the Exmark Parts Plus® and if it arrive in accordance to the program.
6. Who pays for the part and freight if it fails to arrive overnight in accordance to the program?
 - A. Under any circumstance the customer does not pay.
 - B. If the part does not arrive overnight due to:
 1. The dealer not submitting the Exmark Parts Plus® order to his Exmark distributor by 1:00 p.m., the dealer pays for the part and freight.
 2. The Distributor being unable to ship the part the same day or not submitting the Exmark Parts Plus® order to Exmark by 3:00 p.m. central time, the Distributor pays for the part and freight.
 3. Exmark being unable to ship the part and the Exmark parts order is received by 3:00 p.m. central time, Exmark pays for the part and freight.
 4. If the part does not arrive overnight due to the shipper (UPS), the shipper pays for the freight and Exmark pays for the part.

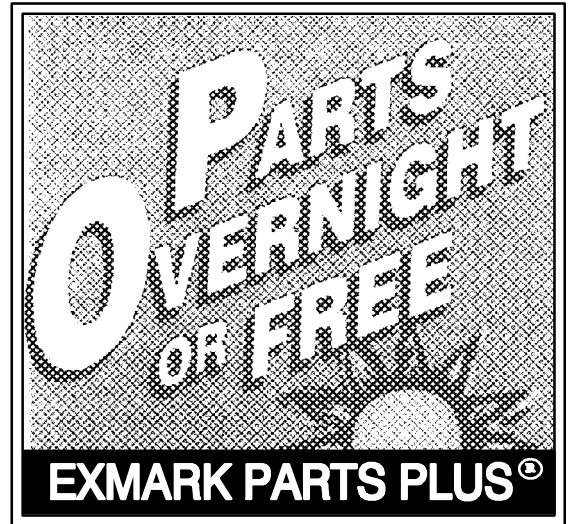

The following restrictions apply -- The Exmark Parts Plus® Program is available only through participating Exmark Dealers and applies only to orders submitted on this program Monday through Thursday. Parts Plus service is available only in the 48 contiguous United States. UPS has initiated a Saturday delivery program to many areas of the continental United States and can be requested for an overnight shipment on Friday to be delivered Saturday. The next day air charge, plus the Saturday delivery fee will be the responsibility of the purchaser. Exmark Mfg. will assume no responsibility for Saturday delivery shipments. To qualify, all Exmark Parts Plus® orders must be received by Exmark by 3:00 p.m. central time. Orders must be six line items or less. Exclusions from the Exmark Parts Plus® Program are: Any wholegood or accessory in its entirety, engines and engine replacement parts, 5-speed Peerless transmissions and 5-speed transaxles, hydraulic or hydrostatic wheel motors, cutter decks and engine decks or any item exceeding United Parcel Service size and weight restrictions.

Due to UPS restrictions, aerosol spray paint is considered a hazardous material and cannot be shipped via UPS next day or Second Day Air.

Exmark Manufacturing stocks a limited supply of parts for transaxles, pumps and wheel motors. These parts can be ordered for Next Day Air shipment but will not be guaranteed per the Parts Plus Program.

CONGRATULATIONS on the purchase of your Exmark Mower. This product has been carefully designed and manufactured to give you a maximum amount of dependability and years of trouble-free operation.

OPERATOR'S MANUAL

This manual contains assembly, operating, maintenance, adjustment and safety instructions for your Exmark mower.

BEFORE OPERATING YOUR MOWER, CAREFULLY READ THIS MANUAL IN ITS ENTIRETY.

By following the operating, maintenance and safety instructions, you will prolong the life of your mower, maintain its maximum efficiency and promote safe operation.

If additional information is needed, or should you require trained mechanic service, contact your authorized Exmark equipment dealer or distributor.

All Exmark equipment dealers and distributors are kept informed of the latest methods of servicing and are equipped to provide prompt and efficient service in the field or at their service stations. They carry ample stock of service parts or can secure them for you from the factory.

All Exmark parts are thoroughly tested and inspected before leaving the factory; however, attention is required on your part if you are to obtain the fullest measure of satisfaction and performance.

Contents

	Page
Specifications	1
Introduction	1
Safety	2
General Lawn Mower Safety	2
Exmark Lawn Mower Safety	4
Safety and Instruction Decals	5
Assembly	6
Installing the Handle	6
Installing the Starter Rope	6
Installing the Discharge Tunnel Plug	6
Before Starting	7
Filling the Crankcase with Oil	7
Filling the Fuel Tank with Gasoline	7
Operation	8
Controls	8
Starting the Engine	9
Stopping the Engine	9
Using the Self-propel Drive	9
Using the Discharge Tunnel Plug	10
Adjusting the Cutting Height	10
Using the Grass Bag	10
Operating Tips	11
Maintenance	13
Recommended Maintenance Schedule	13
Checking the Engine Oil Level	14
Cleaning the Underside of the Lawn Mower Housing	14
Cleaning the Discharge Tunnel and Plug	14
Servicing the Air Filter	15
Changing the Engine Oil	15
Maintaining the Cutting Blade	16
Emptying the Fuel Tank and Cleaning the Fuel Filter	17
Cleaning under the Belt Cover	18
Lubricating the Pivot Arms	18
Adjusting the Self-propel Drive	18
Servicing the Spark Plug	18
Lubricating the Gear Case	19
Adjusting the Blade Brake Cable	19
Servicing the Wheels	20
Changing the Oil Filter	20
Storage	21
Preparing the Fuel System	21
Preparing the Engine	21
General Information	21
Removing the Lawn Mower from Storage	21
Accessories	22

Troubleshooting	23
Limited Warranty	
Exmark Commercial Turf Equipment	26

Specifications

Model Number:	M216KA, M216KASP
Engine:	Kawasaki 6.0HP OHV 3300 RPM (No load)
Fuel System:	
Capacity:	1.37 qt. (1.3 L)
Fuel filter:	Replaceable inline
Transmission:	
3 speeds forward	
Speed range:	
First	1.8 mph (2.9 km/h)
Second	2.7 mph (4.3 km/h)
Third	3.8 mph (6.1 km/h)
Cutting Width:	21 in.
Cutting Height:	
Adjusts in 1/2 in. (1.3 cm) increments from .75 in. (1.9 cm) to 3.25 in. (8.3 cm)	
Grass Catcher Capacity	2.5 Bu. (88 L)
Weight (with bag):	
M216KA	95 lb. (43.1 kg)
M216KASP	107 lb. (48.5 kg)

Introduction

Read this manual carefully to learn how to operate and maintain your product properly. The information in this manual can help you and others avoid injury and product damage. Although Exmark designs and produces safe products, you are responsible for operating the product properly and safely.

This manual identifies potential hazards and has special safety messages that help you and others avoid personal injury and even death. **Danger**, **Warning**, and **Caution** are signal words used to identify the level of hazard. However, regardless of the hazard, be extremely careful.

Danger signals an extreme hazard that *will* cause serious injury or death if you do not follow the recommended precautions.

Warning signals a hazard that *may* cause serious injury or death if you do not follow the recommended precautions.

Caution signals a hazard that may cause minor or moderate injury if you do not follow the recommended precautions.



This manual uses two other words to highlight information. **Important** calls attention to special mechanical information and **Note**: emphasizes general information worthy of special attention.

Safety

This lawn mower meets or exceeds the CPSC blade safety requirements for walk-behind rotary lawn mowers and the B71.4 specifications of the American National Standards Institute in effect at the time of production.

Improperly using or maintaining this lawn mower can result in injury. To reduce the potential for injury, comply with these safety instructions.

Exmark designed and tested this lawn mower to offer reasonably safe service; however, *failure to comply with the following instructions may result in personal injury.*

 Warning 
<p>Engine exhaust contains carbon monoxide, an odorless, deadly poison that can kill you.</p> <p>Do not run the engine indoors or in an enclosed area.</p>

To ensure maximum safety, best performance, and to gain knowledge of the product, it is essential that you and any other operator of the lawn mower read and understand the contents of this manual before the engine is ever started. Pay particular attention to the safety alert symbol  which means *caution, warning, or danger* — “personal safety instruction.” Read and understand the instruction because it has to do with safety. Failure to comply with the instruction may result in personal injury.

General Lawn Mower Safety

This lawn mower is capable of amputating hands and feet and of throwing objects. Failure to observe the following safety instructions could result in serious injury or death.

Training

- Read this operator’s manual carefully. Be thoroughly familiar with the controls and the proper use of the lawn mower before starting it.
- Never allow children to operate the lawn mower. Local regulations may restrict the age of the operator.

- Never allow adults unfamiliar with these instructions to operate the lawn mower.
- Never mow while people (especially children) or pets are nearby. Stop the lawn mower if anyone enters the area.
- Tragic accidents can occur if the operator is not alert to the presence of children. Children are often attracted to the lawn mower and the mowing activity. Never assume that children will remain where you last saw them.
- Keep children out of the mowing area and under the watchful care of a responsible adult.
- Be alert and turn the lawn mower off if children enter the area.
- Use extra care when approaching blind corners, shrubs, trees, or other objects that may obscure vision.
- Keep in mind that the operator or user is responsible for accidents or hazards occurring to other people or their property.
- See the manufacturer’s instructions for proper operation and installation of accessories. Use only the accessories that are approved by the manufacturer.

Preparation

- Thoroughly inspect the area where you will use the lawn mower, and remove all stones, sticks, wires, bones, and other foreign objects.
- While mowing, always wear substantial footwear and long trousers.
- Do not operate the lawn mower when barefoot or wearing open sandals.
- Always wear safety goggles or safety glasses with side shields when operating the lawn mower.
- Warning: Gasoline is highly flammable. Take the following precautions:
 - Store fuel in containers specifically designed for this purpose.
 - Refuel outdoors only and do not smoke while refuelling.
 - Add fuel before starting the engine. Never remove the cap of the fuel tank or add gasoline while the engine is running or when the engine is hot.
 - If gasoline is spilled, do not attempt to start the engine. Move the lawn mower away from the area of spillage to avoid creating any source of ignition until the gasoline vapors have dissipated.
 - Replace all fuel tank and container caps securely.

- If you must drain the fuel from the fuel tank, do it outdoors.
- Replace faulty mufflers.
- Before using, always visually inspect the blades, blade bolts, and cutter assembly for wear or damage. Replace worn or damaged blades and bolts in sets to preserve balance.
- On multibladed lawn mowers, use care as rotating one blade can cause the other blades to rotate.

Operation

- Do not operate the engine in a confined space where dangerous carbon monoxide fumes can collect.
- Mow only in daylight or in good artificial light.
- Always be sure of your footing on slopes.
- Walk; never run.
- Keep a firm hold on the handle.
- For wheeled rotary lawn mowers, mow across the face of slopes, never up and down.
- Exercise extreme caution when changing the direction on slopes.
- Do not mow excessively steep slopes.
- Use extreme caution when reversing or pulling the lawn mower toward you.
- Before and while moving backward, look behind and down for small children.
- Stop the blade(s) if you must tilt the lawn mower for transportation when crossing surfaces other than grass and when transporting the lawn mower to and from the area to be mowed.
- Never operate the lawn mower with damaged or missing guards or shields, or without safety devices (such as deflectors and grass catchers) in place.
- Do not change the speed settings on the engine.
- Disengage all blade and drive clutches before starting the engine.
- Start the engine carefully according to instructions and with feet well away from the blade(s).
- Do not start the engine when standing in front of the discharge chute.
- Do not put your hands or feet near or under rotating parts. Keep clear of the discharge opening at all times.
- Never pick up or carry a lawn mower while the engine is running.
- Stop the engine and disconnect the spark-plug wire:
 - before clearing blockages or unclogging the chute;
 - before checking, cleaning, or working on the lawn mower;
 - after striking a foreign object. Inspect the lawn mower for damage and make repairs before starting and operating the lawn mower; and
 - if the lawn mower starts to vibrate abnormally (check it immediately).
- Stop the engine:
 - whenever you leave the lawn mower; and
 - before refuelling.
- Reduce the throttle setting during engine run-out and, if the engine has a shutoff valve, turn the fuel off after mowing.
- Stop the blade(s) when crossing gravel drives, walks, or roads.
- Shut the engine off and wait until the blade comes to a complete stop before removing the grass catcher.
- Do not operate the lawn mower while under the influence of alcohol or drugs.
- If the lawn mower should start to vibrate abnormally, stop the engine and check immediately for the cause. Vibration is generally a warning of trouble.

Slopes are a major factor related to slip and fall accidents which can result in a severe injury. If you feel uneasy on a slope, do not mow it.

- Watch for holes, ruts, or bumps. Tall grass can hide obstacles.
- Do not mow near drop-offs, ditches, or embankments. You could lose your footing or balance.
- Do not mow on wet grass. Reduced footing could cause slipping.

Maintenance and Storage

- Keep all nuts, bolts (especially blade attachment bolts), and screws tight to ensure that the lawn mower is in safe working condition.
- Never store the lawn mower with gasoline in the tank inside a building where fumes may reach an open flame or spark.
- Allow the engine to cool before storing the lawn mower in any enclosure.
- To reduce the fire hazard, keep the engine, muffler, battery compartment, and gasoline storage area free of grass, leaves, or excessive grease.
- Check the grass catcher frequently for wear or deterioration.

- Replace worn or damaged parts.
- Use extra care when handling gasoline; gasoline vapors are explosive.
- Never tamper with safety devices. Check their proper operation regularly.
- Keep the lawn mower free of grass, leaves, or other debris buildup. Clean up any oil or fuel spills.
- Stop and inspect the lawn mower if you strike an object. Repair the lawn mower, if necessary, before starting the engine.
- Never attempt to make wheel height adjustments while the engine is running.
- Grass catcher components are subject to wear, damage, and deterioration, which could expose moving parts or allow objects to be thrown. Frequently check the components and replace them with the manufacturer's recommended parts when necessary.
- Lawn mower blades are sharp and can cut. Wrap the blade(s) or wear gloves, and use extra caution when servicing them.
- Do not change the speed settings on the engine.
- If you must drain the fuel from the fuel tank, do it outdoors.
- To ensure the best performance and safety, purchase only genuine Exmark replacement parts and accessories.
- Maintain or replace safety and instruction decals when necessary.
- Do not mow in reverse unless it is absolutely necessary. Always look down and behind before and while backing up.
- Be aware of the lawn mower discharge direction and do not point it at anyone. Do not operate the lawn mower without either the grass catcher or the guard in place.
- Slow down before turning with the lawn mower. Sharp turns on any terrain may cause loss of control.
- Turn off the blades when you are not mowing.
- Keep hands, feet, hair and loose clothing away from the attachment discharge area, the underside of the lawn mower, and any moving parts while the engine is running.
- Stop the engine before removing the grass catcher or unclogging the chute.
- Watch for traffic when operating near or crossing roadways.
- Do not touch the lawn mower or attachment parts which may be hot from operation. Allow the lawn mower to cool down before attempting to maintain, adjust, or service it.

Exmark Lawn Mower Safety

The following list contains safety information specific to Exmark products or other safety information that you must know that is not included in the ANSI standard.

This product is designed for cutting and recycling grass or, when equipped with a grass bagger, for catching cut grass. Any use for purposes other than these could prove dangerous to the user and bystanders.

Note: This engine is not equipped with a spark arrester muffler. It is a violation of California Public Resource Code Section 4442 to use or operate this engine on any forest-, brush-, or grass-covered land. Other states or federal areas may have similar laws.

General Operation

- Ensure that the area is clear of other people before mowing. Stop the lawn mower if anyone enters the area.

Safety and Instruction Decals



Safety decals and instructions are easily visible to the operator and are located near any area of potential danger. Replace any decal that is damaged or lost.

On Mower Housing
(Part No. 39-5770)



On Mower Deck
(Hand-push Model only)
(Part No. 213240)



On Belt Cover
(Self-propel Model only)
(Part No. 52-2620)

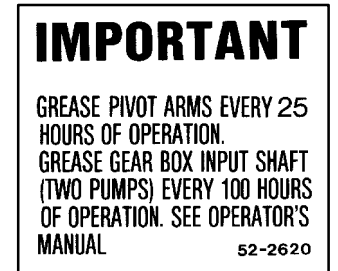

On Control Bar
(Self-propel Model only)
(Part No. 213242)



On Belt Cover
(Hand-push Model only)
(Part No. 52-2610)

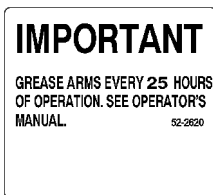

On Plug
(Part No. 76-2110)



On Traction Adjustment Bracket
(Self-propel Model only)
(Part No. 74-1970)



On Handle
(Part No. 104-1329)



On Mower Deck
(Part No. 100-3279)



On Discharge Tunnel
(Part No. 82-9152)



Assembly

Note: Determine the left and right sides of the machine from the normal operating position.

Installing the Handle

1. Mount the handle to the outside of the lawn mower housing (using the bottom hole) with two 5/16-18 x 1-1/4 in. (8 mm x 31 mm) cap screws, washers, and thin nylon insert locknuts.
2. Secure the handle latches to the handle with two 5/16-18 x 1-1/2 in. (8 mm x 38 mm) cap screws, washers, and nylon insert locknuts (Fig. 1).

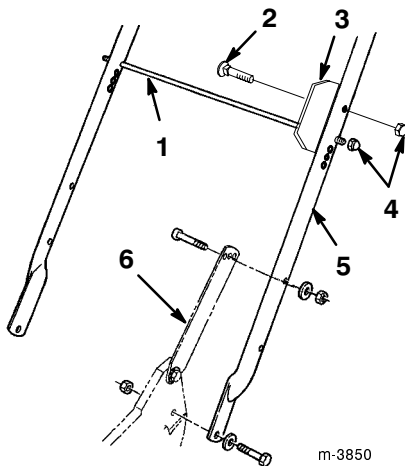

Figure 1

- | | |
|-----------------------|-----------------|
| 1. Bag support rod | 4. Cap locknuts |
| 2. Carriage bolt | 5. Handle |
| 3. Bag aligning plate | 6. Handle latch |

Note: You can adjust the handle height for comfortable operation. Stand behind the handle to determine the height. To adjust the handle height, position the cap screws and the locknuts that secure the handle latches to the handle into the other mounting holes in the latches.

3. Slide the bag support rod through the bag aligning plate and into the second from the top mounting holes in the handle and secure each end with a cap locknut (Fig. 1).
4. Install the carriage bolt through the bag aligning plate and the top hole on the left side of the handle, and secure it with a cap locknut.
5. Use a cable tie to secure the control cables to the left handle below the bag support rod.

Installing the Starter Rope

Pull the starter rope through the rope guide on the handle (Fig. 2).

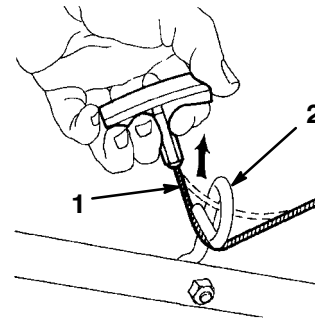

Figure 2

- | | |
|-----------------|---------------|
| 1. Starter rope | 2. Rope guide |
|-----------------|---------------|

Note: To make the rope easier to install, squeeze the control bar on the handle.

Installing the Discharge Tunnel Plug

1. Open the discharge door by pulling forward on the handle and moving it rearward (Fig. 3). Hold the discharge door handle to prevent the spring-loaded door from closing while you insert the plug.

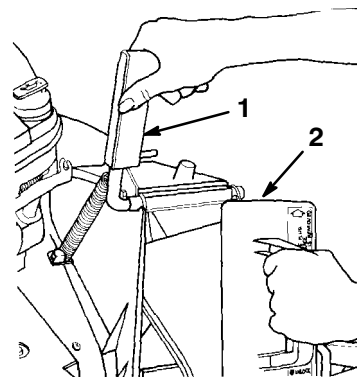

Figure 3

- | | |
|--------------------------|---------------------------|
| 1. Discharge door handle | 2. Plug rotated clockwise |
|--------------------------|---------------------------|

2. Since the plug is slightly wider than the discharge tunnel opening, rotate the plug clockwise slightly while inserting it (Fig. 3).

Note: Ensure that the arrow on the plug decal points upward.

3. Push the plug all the way in until the spring clip on the bottom of the plug clicks into place, locking the plug securely into the discharge tunnel (Fig. 4).

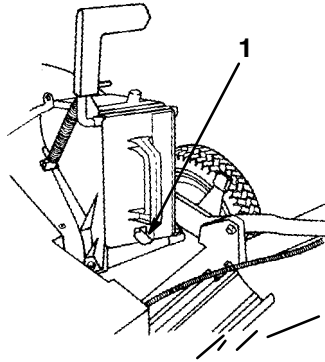

Figure 4

m-275

1. Spring clip

4. Release the discharge door handle to lock the top of the plug.

Before Starting

Filling the Crankcase with Oil

Initially, fill the crankcase with 26 ounces (0.75 liters) of oil. Use only high-quality SAE 30 or SAE 10W30 weight detergent oil that has the American Petroleum Institute (API) service classification SF, SG, SH, or SJ.

Before each use, ensure that the oil level is between the *Add* and *Full* marks on the dipstick (Fig. 5).

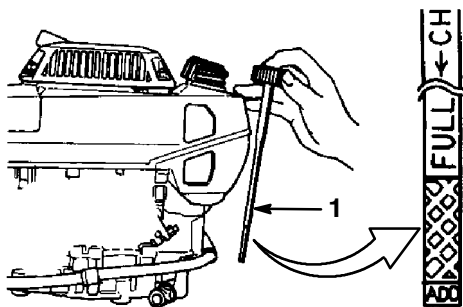

Figure 5

1. Dipstick

Note: When the crankcase is empty, pour about three-fourths of the crankcase capacity of oil in the crankcase, then follow the procedure in this section.

To add oil:

1. Move the lawn mower to a level surface.
2. Clean around the dipstick (Fig. 5).
3. Remove the dipstick by rotating the cap counterclockwise and pulling it out.
4. Wipe the dipstick clean with a clean cloth.
5. Insert the dipstick into the filler neck, then remove it.

Note: To ensure an accurate oil level reading, you must fully install the dipstick.

6. Read the oil level on the dipstick (Fig. 5).
7. If the oil level reading is below the *Add* mark on the dipstick, **slowly** pour only enough oil into the filler hole to raise the oil level to the *Full* mark on the dipstick.

Important Do not overfill the crankcase with oil and run the engine; engine damage will result. Drain the excess oil until the oil level on the dipstick reads *Full*.

8. Insert the dipstick into the filler neck and rotate the cap clockwise until it is tight.

Oil Capacity	
With Oil Filter	26 ounces (0.8 qt. or 0.75 l)
Without Oil Filter	19 ounces (0.6 qt. or 0.55 l)

Filling the Fuel Tank with Gasoline

For best results, use clean, fresh, lead-free gasoline, including *oxygenated* or *reformulated* gasoline, with an octane rating of 87 or higher. To ensure freshness, purchase only the quantity of gasoline that you expect to use in 30 days. Using unleaded gasoline results in fewer combustion deposits and longer engine life. You may use leaded gasoline if unleaded gasoline is not available.

Important Do not add oil to the gasoline.

Important Do not use methanol, gasoline containing methanol, gasohol containing more than 10% ethanol, premium gasoline, or white gas. Using these fuels can damage the engine's fuel system.

Important Do not use gasoline that is more than 30 days old.

Danger

In certain conditions, gasoline is extremely flammable and highly explosive. A fire or explosion from gasoline can burn you and others and can damage property.

- Fill the fuel tank outdoors, in an open area, and when the engine is cold. Wipe up any gasoline that spills.
- Do not fill the fuel tank completely full. Add gasoline to the fuel tank until the level is 1/4 to 1/2 in. (6 to 13 mm) below the bottom of the filler neck. This empty space in the tank allows the gasoline to expand.
- Never smoke when handling gasoline, and stay away from an open flame or where a spark may ignite the gasoline fumes.
- Store gasoline in an approved fuel container and keep it out of the reach of children.
- Never buy more than a 30-day supply of gasoline.

Danger

When fueling, under certain circumstances, a static charge can develop, igniting the gasoline. A fire or explosion from gasoline can burn you and others and damage property.

- Always place gasoline containers on the ground and away from your vehicle before filling.
- Do not fill gasoline containers inside a vehicle or on a truck or trailer bed because interior carpets or plastic truck bed liners may insulate the container and slow the loss of any static charge.
- When practical, remove gasoline-powered equipment from the truck or trailer and refuel the equipment with its wheels on the ground.
- If this is not possible, then refuel such equipment on a truck or trailer from a portable container, not from a gasoline dispenser nozzle.
- If you must use a gasoline dispenser nozzle, keep the nozzle in contact with the rim of the fuel tank or container opening at all times until fueling is complete.

Use a fuel stabilizer/conditioner regularly during operation and storage. A stabilizer/conditioner cleans the engine during operation and prevents gum-like varnish deposits from forming in the engine during periods of storage.

Important Do not use fuel additives other than a fuel stabilizer/conditioner. Do not use fuel stabilizers with an alcohol base such as ethanol, methanol, or isopropanol.

1. Clean around the fuel tank cap (Fig. 6).

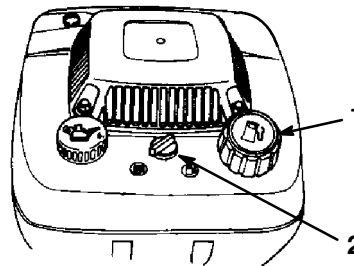

Figure 6

1. Fuel tank cap
2. Fuel valve

2. Remove the cap from the tank.
3. Fill the fuel tank with unleaded gasoline to within 1/4 to 1/2 inch (6 to 13 mm) from the top of the tank. **Do not fill into the filler neck.**

Important Do not fill the tank more than 1/4 inch (6 mm) from the top of the tank because the gasoline must have room to expand.

4. Install the fuel tank cap and wipe up any spilled gasoline.

Operation

Note: Determine the left and right sides of the machine from the normal operating position.

Each time before you mow, make sure that the self-propel drive and the blade control bail operate properly. When you release the blade control bail, the engine and the blade should stop. If they do not, contact an Authorized Service Dealer.

Caution

This machine produces sound levels in excess of 85dBA at the operator's ear and can cause hearing loss through extended periods of exposure.

Wear hearing protection when operating this machine.

Controls

The blade control bail, the throttle control, and the starter handle are on the upper handle as shown in Figure 7.

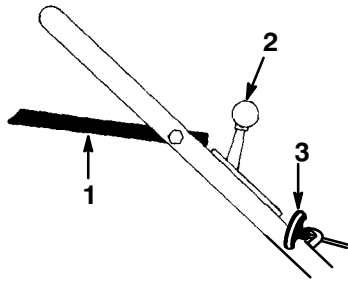

Figure 7

1. Blade control bail
2. Throttle
3. Starter handle

222

Starting the Engine

1. Connect the wire to the spark plug (Fig. 8).

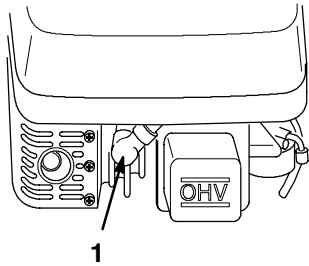



Figure 8

1. Spark-plug wire

m-4353

2. Open the fuel valve (Fig. 6).
3. Move the throttle control to the  (*Choke*) position (Fig. 7).
4. Move the ground speed control to the  (*Neutral*) position (self-propel model only).
5. Lift the blade control bail to the handle and hold it (Fig. 7).
6. Pull the starter handle (Fig. 7) lightly until you feel resistance, then pull it sharply. Allow the rope to return slowly.
7. When the engine starts, regulate the throttle and the ground speed control (self-propel model only) as desired.

Note: If the engine fails to start after three pulls, repeat steps 3 through 7.

Stopping the Engine

Release the blade control bail. Both the engine and the blade should stop. If they do not, contact an Authorized Service Dealer.

Using the Self-propel Drive

Self-propel Model only

The lawn mower has three ground speeds. 1 is slow, 2 is medium, and 3 is fast. The ground speed control is located at the rear of the belt cover (Fig. 9).

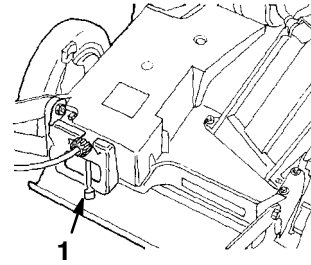



Figure 9

1. Ground speed control

224

1. Move the ground speed control to the  (*Neutral*) position.
2. Start the engine.
3. Squeeze the control bar against the handle to the *Run/Drive* position (Fig. 10).

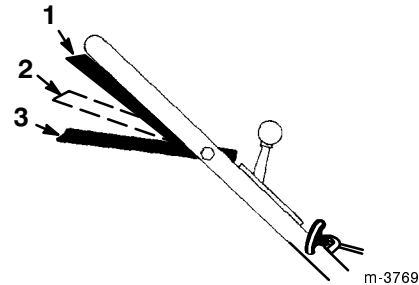

Figure 10

1. *Run/Drive* position
2. *Run/Shift* position
3. *Stop* position

m-3769

Note: Do not shift speeds while you squeeze the control bar against the handle in the *Run/Drive* position; this can damage the transmission. Move the control bar to the *Run/Shift* position (Fig. 10) when you change the ground speed.

Note: You can vary the ground speed by increasing or decreasing the distance between the control bar and the handle. Lower the control bar to slow the lawn mower when making a turn or if the lawn mower is moving too fast for you. If you lower the control bar too far, the lawn mower stops self-propelling. Squeeze the control bar closer to the handle to increase the ground speed. When you hold the control bar tight against the handle, the lawn mower self-propels at the maximum ground speed. Move

the ground speed control to the **N** (Neutral) position when you use the lawn mower for trimming and whenever you leave the lawn mower.

Using the Discharge Tunnel Plug

1. Stop the engine and wait for all moving parts to stop.
2. Insert the plug; refer to Installing the Discharge Tunnel Plug on page 6.
3. To remove the plug, move the discharge door handle rearward and lift up the spring clip on the bottom of the plug. When the plug is unlocked, pull it out of the discharge tunnel.

Note: When grass is thick and lush, clippings may collect on and around the discharge tunnel plug. This may make removing the plug difficult. Clean the plug thoroughly after each use.

Adjusting the Cutting Height

Each wheel is adjusted individually with a wheel height adjustment lever. Cutting heights are 3/4 inch (19 mm), 1-1/4 inches (32 mm), 1-3/4 inches (44 mm), 2-1/4 inches (57 mm), 2-3/4 inches (70 mm), and 3-1/4 inches (83 mm).

! Danger !

Adjusting the cutting height levers could bring your hands into contact with a moving blade and result in serious injury.

- Stop the engine and wait for all movement to stop before adjusting the cutting height.
- Do not put your fingers under the housing when adjusting the cutting height.

1. Pull the wheel height adjustment lever toward the wheel (Fig. 11) and move it to the desired setting.

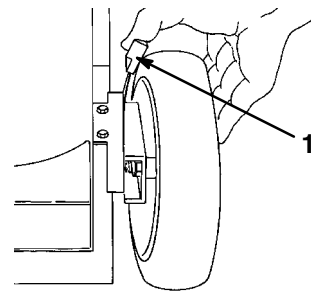

m-225

Figure 11

1. Wheel height adjustment lever
-
2. Release the wheel height adjustment lever and seat it securely in the notch.
 3. Adjust all the wheels to the same cutting height setting.

Using the Grass Bag

Occasionally, you may wish to use the grass bag for bagging extra long grass, lush grass, or leaves.

Installing the Grass Bag

1. Stop the engine and wait for all moving parts to stop.
2. Ensure that the discharge door handle is fully forward and that the pin is engaged in the catch (Fig. 12).

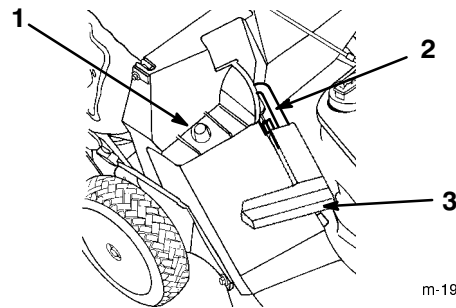

m-1912

Figure 12

1. Bag frame on retaining post
 2. Pin engaged in catch
 3. Handle fully forward. Discharge door closed.
-
3. Slide the hole in the bag frame onto the retaining post on the discharge tunnel (Fig. 12).

4. Set the rear of the bag frame onto the bag support rod.
5. Pull the discharge door handle forward until the pin clears the catch, and move the handle rearward until the pin locks in the bag notch (Fig. 13).

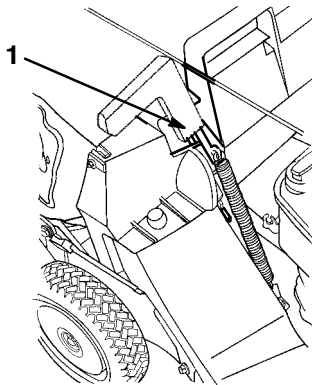

m-1913

Figure 13

1. Pin locked in bag notch

Note: The discharge door in the lawn mower housing is now open.

Mowing with the Grass Bag



Warning



A worn grass bag could allow small stones and other similar debris to be thrown in the operator's or bystander's direction and result in serious personal injury or death to the operator or bystanders.

Check the grass bag frequently. If it is damaged, install a new Exmark replacement bag.

Cut the grass until the bag is full.

Important Do not overfill the bag.

Removing the Grass Bag

1. Stop the engine and wait for all moving parts to stop.
2. Raise the discharge door handle and move it forward to engage the pin with the catch (Fig. 12).
3. Grasp the handles at the front and the rear of the bag and lift the bag off the lawn mower.
4. Gradually tip the bag forward to empty the clippings.

5. To install the bag, refer to Installing the Grass Bag on page 10.



Danger



If the discharge door does not close completely, the lawn mower could throw objects, causing serious personal injury or death.

If you cannot close the door because the grass clippings clog the discharge area, stop the engine and gently move the discharge door handle back and forth until you can close the door completely. If you still cannot close the door, remove the obstruction with a stick, not your hand.



Danger





The lawn mower can throw grass clippings and other objects through an open discharge tunnel. Objects thrown with enough force could cause serious personal injury or death to the operator or bystander.

Never open the door on the discharge tunnel when the engine is running.



Operating Tips

- Review the safety instructions and read this manual carefully before operating the lawn mower.
- Clear the area of sticks, stones, wire, branches, and other debris that the blade could hit and throw.
- Keep everyone, especially children and pets, away from the area of operation.
- Avoid striking trees, walls, curbs, or other solid objects. Never deliberately mow over any object.
- If the lawn mower strikes an object or starts to vibrate, immediately stop the engine, disconnect the wire from the spark plug, and examine the lawn mower for damage.
- Maintain a *sharp blade* throughout the cutting season. Periodically file down nicks on the blade.
- Replace the blade when necessary with an original Exmark replacement blade.

- Mow only dry grass or leaves. Wet grass and leaves tend to clump on the yard and can cause the lawn mower to plug or the engine to stall.

 Warning 
<p>Wet grass or leaves can cause you to slip, contact the blade, and seriously injure you.</p> <p>Mow only in dry conditions.</p>

- Clean the underside of the lawn mower deck after each mowing. See Cleaning the Underside of the Lawn Mower Housing on page 14.
- Keep the engine in good running condition.
- Set the engine speed to the fastest position for the best cutting results.

 Warning 
<p>Operating a lawn mower with its engine running at a speed greater than the factory setting can cause the lawn mower to throw a part of the blade or engine into the operator's or bystander's area and result in serious personal injury or death.</p> <ul style="list-style-type: none"> • Do not change the engine speed setting. • If you suspect the engine speed is faster than normal, contact an Authorized Service Dealer.

- Clean the air filter frequently. Mulching stirs up more clippings and dust which clogs the air filter and reduces engine performance.

Cutting Grass

- Grass grows at different rates at different times of the year. In the summer heat, it is best to cut grass at the 1-3/4 in. (44 mm), 2-1/4 in. (57 mm), or 2-3/4 in. (70 mm) cutting height settings. Cut only about a third of the grass blade at a time. Do not cut below the 1-3/4 in. (44 mm) setting unless the grass is sparse or it is late fall when grass growth begins to slow down.
- When cutting grass over six inches (15 cm) tall, first mow at the highest cutting height setting and walk slower; then mow again at a lower setting for the best lawn appearance. If the grass is too long and the leaves clump on top of the lawn, the lawn mower may plug and cause the engine to stall.
- Alternate the mowing direction. This helps disperse the clippings over the lawn for even fertilization.

If the finished lawn appearance is unsatisfactory, try one or more of the following:

- Sharpen the blade.

- Walk at a slower pace while mowing.
- Raise the cutting height on your lawn mower.
- Cut the grass more frequently.
- Overlap cutting swaths instead of cutting a full swath with each pass.
- Set the cutting height on the front wheels one notch lower than the rear wheels. For example, set the front wheels at 1-3/4 in. (44 mm) and the rear wheels at 2-1/4 in. (57 mm).

Cutting Leaves

- After cutting the lawn, ensure that half of the lawn shows through the cut leaf cover. You may need to make more than one pass over the leaves.
- For light leaf coverage, set all the wheels at the same cutting height setting.
- If there are more than five inches (12.7 cm) of leaves on the lawn, set the front cutting height one or two notches higher than the rear cutting height. This makes it easier to feed the leaves under the lawn mower deck.
- Slow down your mowing speed if the lawn mower does not cut the leaves finely enough.
- If you mow over oak leaves, you can add lime to the grass in the spring to reduce the acidity of the oak leaves.

Maintenance



Note: Determine the left and right sides of the machine from the normal operating position.

Recommended Maintenance Schedule

Maintenance Service Interval	Maintenance Procedure
Each Use	<ul style="list-style-type: none"> • Check the engine oil level. • Check the stopping time of the blade brake. The blade must stop within three seconds of releasing the bail; if it does not, contact an Authorized Service Dealer for repair. • Remove grass clippings and dirt from under the housing. • Clean the discharge tunnel and the discharge tunnel plug.
5 Hours	<ul style="list-style-type: none"> • Check the blade and the engine mounting fasteners. Tighten loose fasteners.
25 Hours	<ul style="list-style-type: none"> • Clean the foam pre-cleaner of the air cleaner.
50 Hours	<ul style="list-style-type: none"> • Change the engine oil (without the oil filter).¹ • Sharpen or replace the blade; maintain it more frequently if the edge dulls quickly in rough or in sandy conditions. • Check for leaks in the fuel system and/or a deteriorating fuel hose. Replace parts if necessary. • Clean the fuel filter. • Remove grass clippings and debris from under the belt cover. • Lubricate the pivot arms (self-propel model only).
75 Hours	<ul style="list-style-type: none"> • Adjust the self-propel drive system (self-propel model only).
100 Hours	<ul style="list-style-type: none"> • Change the engine oil and the oil filter. • Inspect the spark plug and replace it if necessary. • Clean the cooling system; remove grass clippings, debris, or dirt from the engine air cooling fins and starter. Clean the system more frequently in dirty or high-chaff conditions. • Lubricate the gear case (self-propel model only). • Adjust the blade brake cable. • Service the wheels.
150 Hours	<ul style="list-style-type: none"> • Replace the paper air filter. Replace it more frequently in dusty operating conditions.
Storage	<ul style="list-style-type: none"> • Empty the fuel tank before repairs as directed or before storage.

¹Change the engine oil after the first eight operating hours.

Important Refer to your engine operator's manual for additional maintenance procedures.

	<h3>Caution</h3>	
<p>If you leave the wire on the spark plug, someone could accidentally start the engine and seriously injure you or other bystanders.</p> <p>Disconnect the wire from the spark plug before you do any maintenance. Set the wire aside so that it does not accidentally contact the spark plug.</p>		

Checking the Engine Oil Level

Before you use the lawn mower, make sure that the oil level is between the *Add* and the *Full* marks as shown on the dipstick (Fig. 5). If the oil level is below the *Add* mark, add oil. Refer to Filling the Crankcase with Oil on page 7.

Cleaning the Underside of the Lawn Mower Housing

To ensure the best performance, keep the underside of the lawn mower housing clean (Fig. 14).

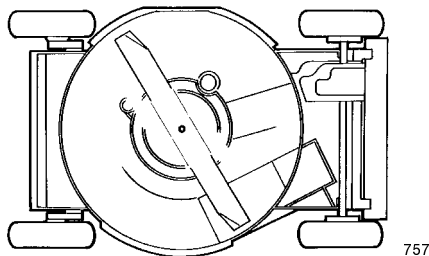

Figure 14

Washing Method

1. Position the lawn mower on a flat concrete or asphalt surface near a garden hose.
2. Start the engine.
3. Hold the running garden hose at handle level and direct the water to flow on the ground just in front of the right rear tire (Fig. 15).

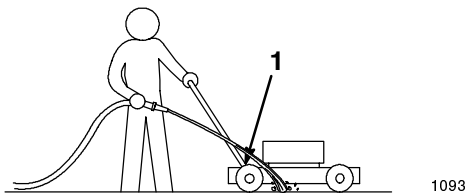

Figure 15

1. Rear right wheel

Note: The blade will draw in water and wash out clippings. Let the water run until you no longer see clippings being washed out from under the housing.

4. Stop the engine and wait for all moving parts to stop.
5. Turn off the garden hose.
6. Start the lawn mower and let it run for a few minutes to dry out the moisture on the lawn mower and its components.

Scraping Method

If washing does not remove all debris from under the lawn mower, scrape it clean.

1. Disconnect the wire from the spark plug (Fig. 8).
2. Drain the fuel from the fuel tank. Refer to Emptying the Fuel Tank and Cleaning the Fuel Filter on page 17.

Warning	
⚠	
Tipping the lawn mower may cause the fuel to leak from the carburetor or the fuel tank. Gasoline is extremely flammable, highly explosive, and, under certain conditions, can cause personal injury or property damage.	
Avoid fuel spills by running the engine dry or by removing the gasoline with a hand pump; never siphon.	

3. Tip the lawn mower onto its **right** side (air filter up) (Fig. 14).
4. Remove the dirt and grass clippings with a hardwood scraper. Avoid burrs and sharp edges.
5. Turn the lawn mower upright.
6. Fill the fuel tank.
7. Connect the wire to the spark plug.

Cleaning the Discharge Tunnel and Plug

Remove the plug from the discharge tunnel and clean it after each use.

Always be sure that the discharge tunnel door closes securely when you release the handle. If the debris prevents the discharge door from closing securely, clean the inside of the discharge tunnel and the door thoroughly.



Warning



Grass clippings and other objects can be thrown from an open discharge tunnel and cause serious injury or kill the operator or bystanders.

Never start or operate the lawn mower unless *one* of the following is true:

- The discharge tunnel plug is locked securely in the discharge tunnel.
- The grass bag is locked in place.
- The optional side discharge chute is locked in place.
- The discharge tunnel door is locked in place.

Servicing the Air Filter

Clean the foam pre-cleaner every 25 operating hours. Replace the paper air filter once every season or every 150 operating hours; replace it more frequently in dusty conditions.

Important Do not operate the engine without the air filter assembly; extreme engine damage will occur.

1. Stop the engine and wait for all moving parts to stop.
2. Disconnect the wire from the spark plug (Fig. 8).
3. Remove the bolt that secures the air cleaner cover (Fig. 16).

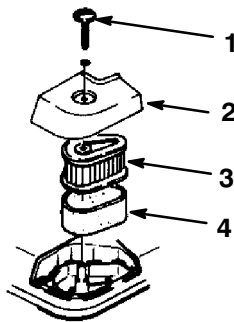

Figure 16

- | | |
|----------|---------------------|
| 1. Bolt | 3. Paper air filter |
| 2. Cover | 4. Foam pre-cleaner |

4. Remove the cover and clean it thoroughly (Fig. 16).
5. Remove the foam pre-cleaner and wash it with a mild detergent and water, then blot it dry (Fig. 16).
6. Saturate the pre-cleaner with oil, then squeeze it (do not twist) to remove the excess oil.
7. Remove the paper air filter and discard it (Fig. 16).

Important Do not try to clean a paper filter.

8. Install the foam pre-cleaner on the new paper air filter.
9. Install the air cleaner assembly.
10. Install the cover and secure it with the bolt.

Changing the Engine Oil

Change the oil after the first **eight** operating hours and then after every 50 operating hours (without the oil filter), and every 100 operating hours (with the oil filter).

1. Run the engine to warm the engine oil.

Note: Warm oil flows better and carries more contaminants.



Warning



Oil may be hot after engine has been run, and contact with hot oil can cause severe personal injury.

Avoid contacting the hot engine oil when you drain it.

2. Stop the engine and wait for all moving parts to stop.
3. Disconnect the wire from the spark plug (Fig. 8).
4. Place a suitable drain pan under the side oil drain plug.
5. Raise the left side of the lawn mower at least 12 inches (30 cm) and open the side oil drain plug (Fig. 17).

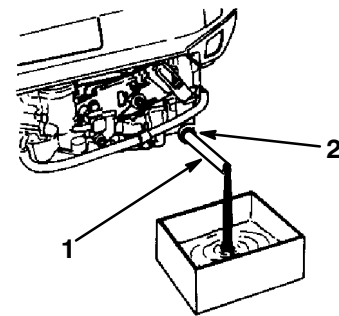

m-4354

Figure 17

- | | |
|-------------------|------------------------|
| 1. Oil drain tube | 2. Side oil drain plug |
|-------------------|------------------------|

6. Insert the oil drain tube over the drain plug and lower the lawn mower (Fig. 17).
7. Raise the **right** side of the lawn mower (air filter up) to drain the oil into the drain pan.
8. Lower the right side of the lawn mower.

- Remove the oil drain tube and tighten the side oil drain plug.

Important Do not over-tighten the side oil drain plug; it may cause damage to the crankcase cover. Torque the side oil drain plug to 190 in-lb (23 N-m).

- Recycle the used oil according to local codes.
- Fill the crankcase to the *Full* line on the dipstick with fresh oil. Refer to the Filling the Crankcase with Oil on page 7.
- Wipe up any spilled oil.

Maintaining the Cutting Blade

Always mow with a sharp blade. A sharp blade cuts cleanly and without tearing or shredding the grass blades.

- Stop the engine and wait for all moving parts to stop.
- Disconnect the wire from the spark plug (Fig. 8).
- Drain the gasoline from the fuel tank; refer to Emptying the Fuel Tank and Cleaning the Fuel Filter on page 17.
- Tip the lawn mower onto its **right** side (air filter up) (Fig. 18).

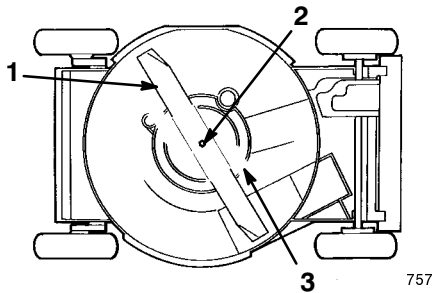

Figure 18

- Blade
- Bolt and lockwasher
- Accelerator

Inspecting the Blade

Carefully examine the blade for sharpness and wear, especially where the flat and the curved parts meet (Fig. 19A). Because sand and abrasive material can wear away the metal that connects the flat and curved parts of the blade, check the blade before using the lawn mower. If you notice a slot or wear (Figs. 19B and 19C), replace the blade; refer to Removing the Blade on page 16.

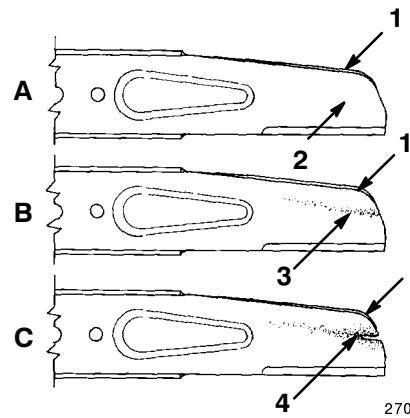

Figure 19

- Sail
- Flat part of blade
- Wear
- Slot formed

Note: For the best performance, install a new blade before the cutting season begins. During the year, file down any small nicks to maintain the cutting edge.

Danger

A worn or damaged blade can break, and a piece of the blade could be thrown into the operator's or bystander's area, resulting in serious personal injury or death.

- Inspect the blade periodically for wear or damage.
- Replace a worn or damaged blade.

Removing the Blade

- Grasp the end of the blade using a rag or a thickly padded glove.
- Remove the blade bolt, the lockwasher, the accelerator, and the blade (Fig. 20).

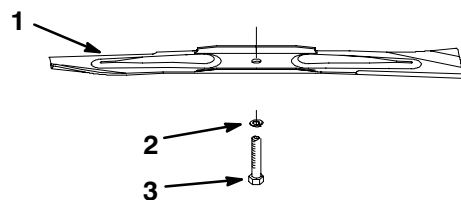

Figure 20

- Blade
- Lock washer
- Blade bolt

Sharpening the Blade

File the top side of the blade to maintain its original cutting angle (Fig. 21A) and inner cutting edge radius (Fig. 21B). The blade will remain balanced if you remove the same amount of material from both cutting edges.

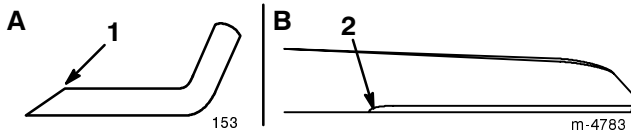

Figure 21

1. Sharpen at this angle only
2. Maintain the original radius here

Balancing the Blade

1. Check the balance of the blade by placing the center hole of the blade over a nail or screwdriver shank clamped horizontally in a vise (Fig. 22).

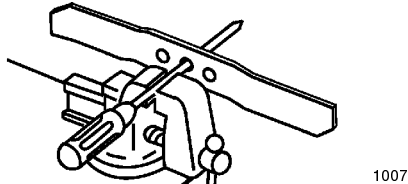

Figure 22

Note: You can also check the balance using a commercially manufactured blade balancer.

2. If either end of the blade rotates downward, file that end (not the cutting edge or the end near the cutting edge). The blade is properly balanced when neither end drops.

Installing the Blade

1. Install a sharp, balanced Exmark blade, the accelerator, the lockwasher, and the blade bolt. The sail of the blade must point toward the top of the lawn mower housing for proper installation. Torque the blade bolt to 50 ft-lb (68 N·m).



Warning



Operating the lawn mower without the accelerator in place can cause the blade to flex, bend, or break, resulting in serious injury or death to the operator or bystanders.

Do not operate the lawn mower without the accelerator.

2. Return the lawn mower to its upright position.
3. Connect the wire to the spark plug.

Emptying the Fuel Tank and Cleaning the Fuel Filter

Clean the fuel filter element every 50 operating hours.

1. Stop the engine and wait for it to cool down.

Important Drain gasoline from a cold engine only.

2. Disconnect the wire from the spark plug (Fig. 8).
3. Remove the fuel tube by loosening the tube clamp at the carburetor (Fig. 23).

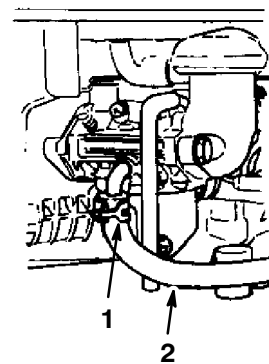

Figure 23

1. Tube clamp
2. Fuel tube

4. Open the fuel valve by turning the lever to the open position (Fig. 6).
5. Drain the gasoline completely from the tank and fuel line into an approved fuel container.
6. Remove the fuel tube on the fuel tank by loosening the tube clamp (Fig. 24).

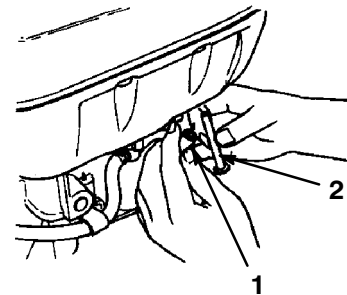

Figure 24

1. Fuel tube
2. Fuel filter

7. Remove the fuel filter from the fuel tank (Fig. 24).
8. Clean the fuel filter with high flash-point solvent.

9. Firmly install the filter, tubes, and clamps.

Cleaning under the Belt Cover

Self-propel Model only

Keep the area under the belt cover free of debris.

1. Stop the engine and wait for all moving parts to stop.
2. Remove the bolts that secure the belt cover (Fig. 25) to the lawn mower housing.

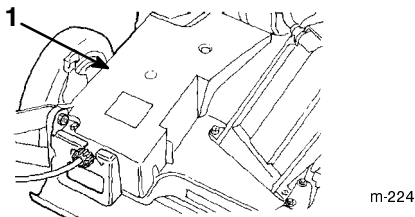

Figure 25

1. Belt cover

3. Lift off the cover and brush out all the debris around the belt area.
4. Install the belt cover.

Lubricating the Pivot Arms

Self-propel Model only

After every 50 operating hours or when the season ends, lubricate the pivot arms.

1. Move the rear wheel cutting height levers to the center setting.
2. Wipe the grease fittings with a clean rag (Fig. 26).

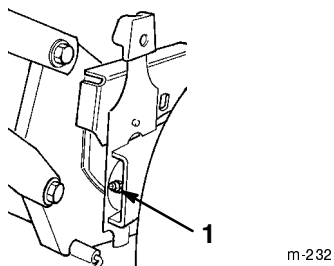

Figure 26

1. Grease fitting

3. Install a grease gun onto the fitting and gently apply two or three pumps of #2 multi-purpose lithium base grease (Fig. 26).

Note: Excessive grease pressure may damage the seals.

Adjusting the Self-propel Drive

Self-propel Model only

If the lawn mower does not self-propel or has a tendency to creep forward when the control bar is **more** than 1-1/2 inches (3.8 cm) from the handle, adjust the wheel drive control knob on the rear of the gear box.

1. Close the door in the lawn mower housing and remove the grass bag.
2. Rotate the control knob clockwise 1/2 turn if the lawn mower does not self-propel. If the lawn mower creeps forward, rotate the knob 1/2 turn counterclockwise to loosen the belt (Fig. 27).

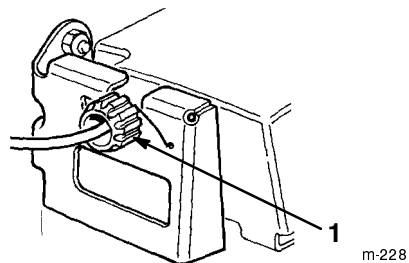

Figure 27

1. Control knob

3. Slowly pull the lawn mower backward while you gradually move the control bar toward the handle.

Note: The adjustment is correct when the rear wheels stop turning and the control bar is about one inch (2.5 cm) from the handle (Fig. 28).

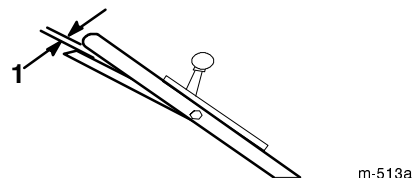

Figure 28

1. One inch (2.5 cm)

Servicing the Spark Plug

Check the spark plug after every 100 operating hours. Use an *NGK BPR5ES* spark plug or equivalent.

1. Stop the engine and wait for all moving parts to stop.
2. Disconnect the wire from the spark plug (Fig. 8).
3. Clean around the spark plug.
4. Remove the spark plug from the cylinder head.

Important Replace a cracked, fouled, or dirty spark plug. Do not clean the electrodes because grit entering the cylinder can damage the engine.

- Set the gap on the plug to 0.030 in. (0.76 mm) (Fig. 29).

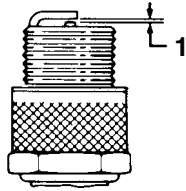

m-110

Figure 29

- 0.030 in. (0.76 mm)

- Install the spark plug and the gasket seal.
- Torque the plug to 17 ft-lb (23 N-m).
- Connect the wire to the spark plug.

Lubricating the Gear Case

Self-propel Model only

After every 100 operating hours, grease the gear case.

- Remove the grass bag.
- Install a grease gun onto the fitting through the belt cover opening (Fig. 30).

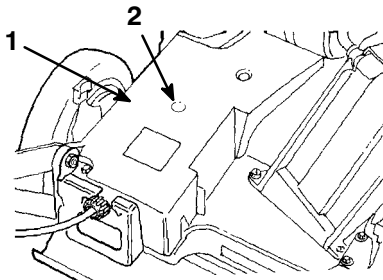

m-224

Figure 30

- Belt cover
- Grease fitting

- Gently apply one to two pumps of #2 multi-purpose lithium-base grease.
- Install the grass bag.

Adjusting the Blade Brake Cable

Whenever you install a new blade brake cable assembly, adjust it.

- Stop the engine and wait for all moving parts to stop.

- Disconnect the wire from the spark plug (Fig. 8).
- Check the adjustment of the cable by moving the control bar toward the handle until you remove the slack in the cable. The gap between the brake lever and the handle must be between 3/16 and 1/4 in. (5 and 6 mm). To adjust the cable, go to step 4.
- To adjust the cable, do the following:

Hand-push Model

- Loosen the jam nut on the blade brake cable (Fig. 31).

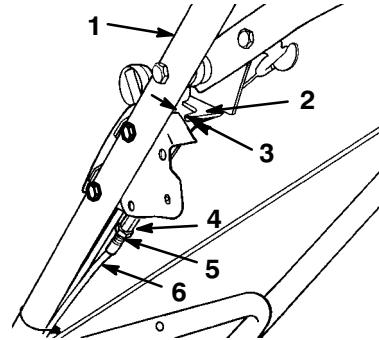

483

Figure 31

- Handle
- Brake lever
- 3/16 to 1/4 in. (5 to 6 mm)
- Cable adjuster
- Jam nut
- cable conduit

- Insert a 3/16 to 1/4 in. (5 to 6 mm) object between the brake lever and the handle.
- Turn the cable adjuster on the brake cable until you remove the slack.
- Tighten the nut.

Self-propel Model

- Loosen the nut on the cable bracket (Fig. 32).

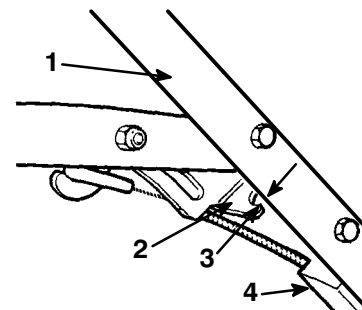

Figure 32

- Handle
- Brake lever
- 3/16 to 1/4 in. (5 to 6 mm)
- cable bracket

- Insert a 3/16 to 1/4 in. (5 to 6 mm) object between the brake lever and the handle.

- C. Pull down on the cable conduit until you remove the slack from the wire.
- D. Tighten the nut.

Servicing the Wheels

Removing the Wheels

1. Stop the engine and wait for all moving parts to stop.
2. Disconnect the wire from the spark plug (Fig. 8).
3. Remove the cap screw, the wheel spacer, and the locknut mounting the wheel to the pivot arm (Fig. 33).

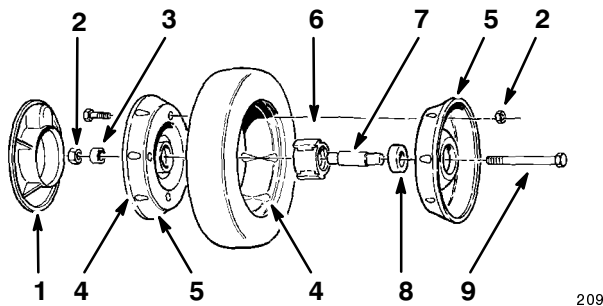

Figure 33

- | | |
|-------------------------------------|-------------------------|
| 1. Plastic cover (rear wheels only) | 5. Wheel half |
| 2. Locknuts | 6. Bearing/hub assembly |
| 3. Wheel spacer | 7. Bearing spacer |
| 4. Lug | 8. Bearing (2) |
| | 9. Cap screw |

4. Separate the wheel halves from the tire by removing four cap screws and four locknuts (Fig. 33).

Note: If you remove the bearings from the bearing/hub assembly, remove them by pressing on the bearing spacer (Fig. 33).

Assembling the Wheels

1. Position the tire onto one wheel half, aligning the lugs on each (Fig. 33).
2. Place the bearing/hub assembly into the center hole of the wheel half. Ensure that the legs of the hub are positioned over the flange of the hole (Fig. 33).
3. Place the other wheel half onto the bearing/hub assembly, aligning the wheel and the tire lugs and the mounting holes (Fig. 33).
4. Using two 1/4–20 x 1.5 in. (6 x 38 mm) fully threaded screws or bolts and non-locking nuts, loosely secure the wheel halves together. Mount the screws or bolts in the opposing holes (Fig. 33).
5. Check the alignment of all parts and tighten the screws, alternating from side to side for a uniform fit, until the wheel halves are drawn together (Fig. 33).

6. Install the two cap screws and two locknuts previously removed in the remaining holes in the wheel halves and tighten. Remove the two long screws or bolts and replace them with two cap screws and two locknuts (Fig. 33).
7. Install the wheel to the pivot arm with the cap screws, a spacer, and a locknut. Ensure that the spacer is positioned between the wheel hub and the pivot arm (Fig. 33).

Changing the Oil Filter

Change the oil filter every 100 operating hours.

1. Run the engine to warm the oil.

! **Warning** !

Oil may be hot after engine has been run, and contact with hot oil can cause severe personal injury.

Avoid contacting the hot engine oil when you drain it.

2. Stop the engine and wait for all moving parts to stop.
3. Disconnect the wire from the spark plug (Fig. 8).
4. Drain the engine oil; refer to Changing the Engine Oil on page 15.
5. Place a suitable drain pan under the oil filter connection (Fig. 34).

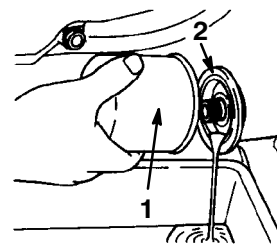

Figure 34

- | | |
|---------------|---------------------|
| 1. Oil filter | 2. Mounting surface |
|---------------|---------------------|
6. Rotate the oil filter counterclockwise to remove it.
 7. Apply a film of clean engine oil onto the seal of the new oil filter.
 8. Install new oil filter by rotating it clockwise until the seal contacts the mounting surface. Then rotate the oil filter 3/4 turn more by hand.
 9. Fill the crankcase to the *Full* line on the dipstick with fresh oil. Refer to Filling the Crankcase with Oil on page 7.



10. Install the spark plug wire.
11. Run the engine for about three minutes.
12. Stop the engine, wait for all moving parts to stop, and check for oil leakage around the filter.
13. Add oil to compensate for the oil in the oil filter. Refer to Checking the Engine Oil Level on page 14.

Storage

To prepare the lawn mower for off-season storage, perform the recommended maintenance procedures. Refer to Maintenance on page 13.

Store the lawn mower in a cool, clean, dry place. Cover the lawn mower to keep it clean and protected.

Preparing the Fuel System

 Warning 
<p>Gasoline can vaporize if you store it over long periods of time and explode if it comes into contact with an open flame.</p> <ul style="list-style-type: none"> • Do not store gasoline over long periods of time. • Do not store the lawn mower with gasoline in the fuel tank or the carburetor in an enclosure with an open flame. (For example, a furnace or a water heater pilot light.) • Allow the engine to cool before storing it in any enclosure.

Empty the fuel tank when mowing the last time before storing the lawn mower.

1. Run the lawn mower until the engine stops from running out of fuel.
2. Prime the engine and start it again.
3. Allow the engine to run until it stops. When you can no longer start the engine, it is sufficiently dry.

Preparing the Engine

1. While the engine is still warm, change the oil from the crankcase. Refer to Changing the Engine Oil on page 15.
2. Remove the spark plug (Fig. 8).
3. Using an oil can, add about one tablespoon of oil to the crankcase through the spark plug hole.
4. Slowly rotate the engine several times, using the starter rope, to distribute the oil.

5. Install the spark plug but **do not** connect the wire to the spark plug.

General Information

1. Clean the lawn mower housing. Refer to Cleaning the Underside of the Lawn Mower Housing on page 14.
2. Clean any dirt and chaff from the cylinder, cylinder head fins, and blower housing.
3. Remove grass clippings, dirt, and grime from the external parts of the engine, the shrouding, and the top of the lawn mower housing.
4. Check the condition of the blade. Refer to Maintaining the Cutting Blade on page 16.
5. Service the air filter; refer to Servicing the Air Filter on page 15.
6. Lubricate the pivot arms (self-propel model only); refer to Lubricating the Pivot Arms on page 15.
7. Tighten all nuts, bolts, and screws.
8. Touch up all rusted or chipped paint surfaces with paint available from an Authorized Service Dealer.

Removing the Lawn Mower from Storage

1. Check and tighten all fasteners.
2. Remove the spark plug and spin the engine rapidly using the starter to blow excess oil from the cylinder.
3. Clean the spark plug or replace it if it is cracked, broken, or if the electrodes are worn.
4. Install the spark plug and torque it to 17 ft-lb (23 N·m).
5. Perform any needed maintenance procedures; refer to Maintenance on page 13.
6. Fill the fuel in the fuel tank with fresh gasoline.
7. Check the engine oil level.
8. Connect the wire to the spark plug.

Accessories

You may purchase the following accessory from an Authorized Service Dealer:

Side Discharge Kit

You can install the side discharge kit in seconds. It is rear mounted in place of the grass bag. It disperses clippings while trimming on both sides (Fig. 35).

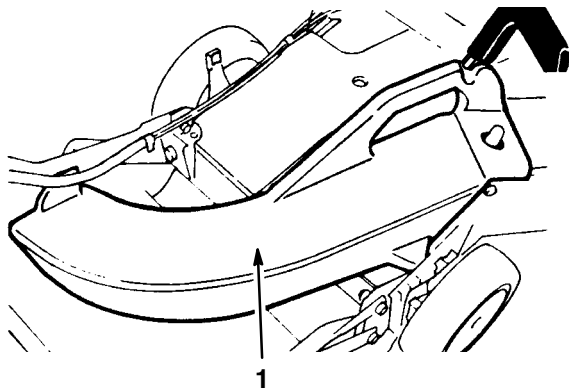

2047

Figure 35

1. Side discharge chute
-

Troubleshooting

Exmark designed and built your lawn mower for trouble-free operation. Check the following components and items carefully, and refer to Maintenance on page 13 for more information. If a problem continues, contact an Authorized Service Dealer.

Problem	Possible Causes	Corrective Action
Engine does not start	<ol style="list-style-type: none"> 1. The fuel tank is empty or the fuel system contains stale fuel. 2. The throttle lever is not in the <i>Choke</i> position. 3. The wire is not connected to the spark plug. 4. The spark plug is pitted, fouled, or the gap is incorrect. 	<ol style="list-style-type: none"> 1. Drain and/or fill the fuel tank with fresh gasoline. If the problem persists, contact an Authorized Service Dealer. 2. Move the throttle lever to the <i>Choke</i> position. 3. Connect the wire to the spark plug. 4. Check the spark plug and adjust the gap if necessary. Replace the spark plug if it is pitted, fouled, or cracked.
Engine starts hard or loses power	<ol style="list-style-type: none"> 1. The fuel tank contains stale fuel. 2. The fuel cap vent hole is plugged. 3. The air filter element is dirty and is restricting the air flow. 4. The underside of the lawn mower deck contains clippings and debris. 5. The spark plug is pitted, fouled, or the gap is incorrect. 6. The engine oil level is low or the oil is dirty. 	<ol style="list-style-type: none"> 1. Drain and fill the fuel tank with fresh gasoline. 2. Clean the fuel cap vent hole or replace the fuel cap. 3. Clean the air filter pre-cleaner and/or replace the paper air filter. 4. Clean the underside of the lawn mower deck. 5. Check the spark plug and adjust the gap if necessary. Replace the spark plug if it is pitted, fouled, or cracked. 6. Check the engine oil. Change the oil if it is dirty or add oil if it is low.
Engine runs rough	<ol style="list-style-type: none"> 1. The wire is not connected to the spark plug. 2. The spark plug is pitted, fouled, or the gap is incorrect. 3. The throttle lever is not in the <i>Fast</i> position. 4. The air filter element is dirty and is restricting the air flow. 	<ol style="list-style-type: none"> 1. Connect the wire to the spark plug. 2. Check the spark plug and adjust the gap if necessary. Replace the spark plug if it is pitted, fouled, or cracked. 3. Move the throttle lever to the <i>Fast</i> position. 4. Clean the air filter pre-cleaner and/or replace the paper air filter.

Problem	Possible Causes	Corrective Action
Lawn mower or engine vibrates excessively	<ol style="list-style-type: none"> 1. The blade is bent or is out of balance. 2. The blade mounting nuts are loose. 3. The underside of the lawn mower deck contains clippings and debris. 4. The engine mounting bolts are loose. 	<ol style="list-style-type: none"> 1. Balance the blade. If the blade is bent, replace it. 2. Tighten the blade mounting nuts. 3. Clean the underside of the lawn mower deck. 4. Tighten the engine mounting bolts.
Uneven cutting pattern	<ol style="list-style-type: none"> 1. All four wheels are not at the same height. 2. The blade is dull. 3. You are mowing in the same pattern repeatedly. 4. The underside of the lawn mower deck contains clippings and debris. 	<ol style="list-style-type: none"> 1. Place all four wheels at the same height. 2. Sharpen and balance the blade. 3. Change the mowing pattern. 4. Clean the underside of the lawn mower deck.
Discharge chute plugs	<ol style="list-style-type: none"> 1. The throttle lever is not in the <i>Fast</i> position. 2. The cutting height is too low. 3. You are mowing too fast. 4. The grass is wet. 5. The underside of the lawn mower deck contains clippings and debris. 	<ol style="list-style-type: none"> 1. Move the throttle lever to the <i>Fast</i> position. 2. Raise the cutting height. 3. Slow down. 4. Allow the grass to dry before mowing. 5. Clean the underside of the lawn mower deck.
Lawn mower does not self-propel (Self-propel model only)	<ol style="list-style-type: none"> 1. The self-propel drive cable is out of adjustment or is damaged. 2. There is debris under the belt cover. 	<ol style="list-style-type: none"> 1. Adjust the self-propel drive cable. Replace the cable if necessary. 2. Clean the debris from under the belt cover.

Limited Warranty

Exmark[®] Commercial Turf Equipment

Exmark Mfg. Co. Inc. and its affiliate, Exmark Warranty Company, pursuant to an agreement between them, jointly warrant pursuant to the terms and conditions herein, that we will repair, replace or adjust any parts manufactured by Exmark and found by Exmark (in the exercise of its reasonable discretion) to be defective in factory material or workmanship.

This warranty is limited to one year from the date of original retail purchase (90 days for rental use) for any Exmark mower that is used for commercial or any other income producing purpose. The blade spindle assemblies will be warranted for three years, one year parts and labor with an additional two years parts only, from date of original retail purchase against defects in materials or workmanship. The hydrostatic traction drive system will be warranted for two full years from date of original retail purchase against defects in materials or workmanship—excluding hoses. We will extend the Peerless 5-speed transmission manufacturer's warranty from 90 days to one year. Belts and tires are warranted for 90 days against defects in materials or workmanship.

The engine warranty is covered by its respective engine manufacturer. Please refer to the engine manufacturer's warranty statement that is included in the literature packet. We are not authorized to handle warranty adjustments on engines. Engine warranties should be referred to the nearest authorized service outlet of the engine manufacturer.

This warranty extends only to the original retail purchaser of the equipment. The warranty may not be assigned or transferred without the prior express written consent of Exmark and Exmark Warranty Company. The warranty commences upon the date of original retail purchase.

The Exmark turf equipment, including any defective part, must be returned to an authorized Exmark service dealer within the warranty period. The warranty shall cover the cost to repair or replace (as determined by us) the defective part, including labor. The expense of delivering the mower to the dealer for warranty work and the expense of returning it back to the owner after repair or replacement will be paid for by the owner. Our responsibility in respect to claims is limited to making the required repairs or replacements. No claim of breach of warranty shall arise from cancellation or rescission of the contract of sale of any Exmark mower. Proof of purchase may be required by the dealer to substantiate any warranty claim. All warranty work must be performed by an authorized Exmark service dealer.

This warranty extends only to turf equipment operated under normal conditions and properly serviced and maintained. The warranty expressly does not cover (1) any defects, damage or deterioration due to normal use, wear and tear, or exposure; (2) normal maintenance services, such as oil change, cleaning, lubrication, or adjustment; (3) replacement of service items, such as oil, lubricants, spark plugs, belts, rubber hoses, or other items subject to normal service replacement; (4) damage or defects arising out of or relating to misuse, neglect, alteration, negligence, or accident; (5) repair or replacement arising from operation of or use of the turf equipment which is not in accordance with operating instructions as specified in the operator's manual or other operational instructions provided by Exmark or Exmark Warranty Company; (6) repair or replacement arising as a result of any operation from turf equipment that has been altered or modified so as to, in determination of Exmark, adversely affect the operation, performance or durability of the equipment or that has altered, modified or affected the turf equipment so as to change the intended use of the product; (7) repair or replacement necessitated by use of parts, accessories or supplies, including gasoline, oil, or lubricants, incompatible with the turf equipment or other than as recommended in the operator's manual or other operational instructions provided by Exmark; (8) repairs or replacements resulting from parts or accessories which have adversely affected the operation, performance, or durability of the turf equipment; or

(9) damage or defects due to or arising out of repair of turf equipment by person or persons other than an authorized Exmark service dealer or the installation of parts other than genuine Exmark or Exmark recommended parts.

As a condition to this warranty, customer shall have read the operator's manual and shall have returned to Exmark Warranty Company, within the prescribed time, the enclosed warranty registration card.

The sole liability of Exmark and Exmark Warranty Company, with respect to this warranty, shall be repair and replacement as set forth herein. Neither Exmark nor Exmark Warranty Company shall have liability for any other cost, loss, or damage, including, but not limited to, any incidental or consequential loss or damage. In particular, Exmark shall have no liability or responsibility for (1) expenses relating to gasoline, oil, or lubricants; (2) loss, cost, or expense relating to transportation or delivery of turf equipment from the location of owner or location where used by owner to or from any authorized Exmark service dealer; (3) travel time, overtime, after hours time, or other extraordinary repair charges of charge relating to repairs or replacements outside of normal business hours at the place of business of the authorized Exmark service dealer; (4) rental of like or similar replacement equipment during the period of any warranty, repair, or replacement work; (5) any telephone or telegram charges or travel charges; (6) loss or damage to person or property other than that covered by the terms of this warranty; (7) any claims for lost revenue, lost profit, or additional cost as a result of a claim of breach of warranty; or (8) attorney's fees.

There are no representations or warranties to the buyer of the turf equipment other than as set forth in this warranty. Any and all statements or representations made by any seller of this equipment, including those set forth in any sales literature or made orally by any sales representative, are superseded by the terms of this warranty. Any affirmation of fact or promise made by Exmark, Exmark Warranty Company, or any of their representatives, to the buyer, which relates to the goods that are the subject of this warranty, shall not be deemed to create any express warranty that such goods shall conform to the affirmation or promise.

THERE ARE NO OTHER UNDERSTANDINGS, AGREEMENTS, REPRESENTATIONS, OR WARRANTIES, EXPRESS OR IMPLIED (INCLUDING BUT NOT LIMITED TO ANY REGARDING THE MERCHANTABILITY OR FITNESS FOR A PARTICULAR PURPOSE), NOT SPECIFIED HEREIN, RESPECTING THE EQUIPMENT WHICH IS THE SUBJECT OF THIS WARRANTY.

This warranty applies to all Exmark turf equipment sold in the United States and Canada and intended to be used for commercial purposes.

**SEE EXMARK'S COMPLETE
LINE OF PRODUCTS FOR TURF CARE**

LAZER Z[®]

LAZER Z[®] HP

TURF RANGER[®]

TURF TRACER[®]

TURF TRACER[®] HP

VIKING HYDRO

METRO[®]

METRO[®] HP

ULTRA VAC[™]

GRASS CATCHER

SELF STEERING SULKY

MICRO-MULCH[™] ACCESSORY

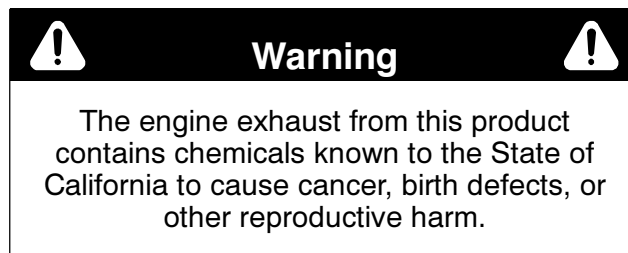

©2000
EXMARK MFG. CO. INC.
INDUSTRIAL PARK BOX 808
BEATRICE, NE 68310
ALL RIGHTS RESERVED

FORM NO. 3325-144
(402) 223-6300
FAX (402) 223-5489
PRINTED IN U. S. A.

