

# MODEL 4100

## 5 Speed Transmission

- 4100-8
- 4100-10
- 4100-12

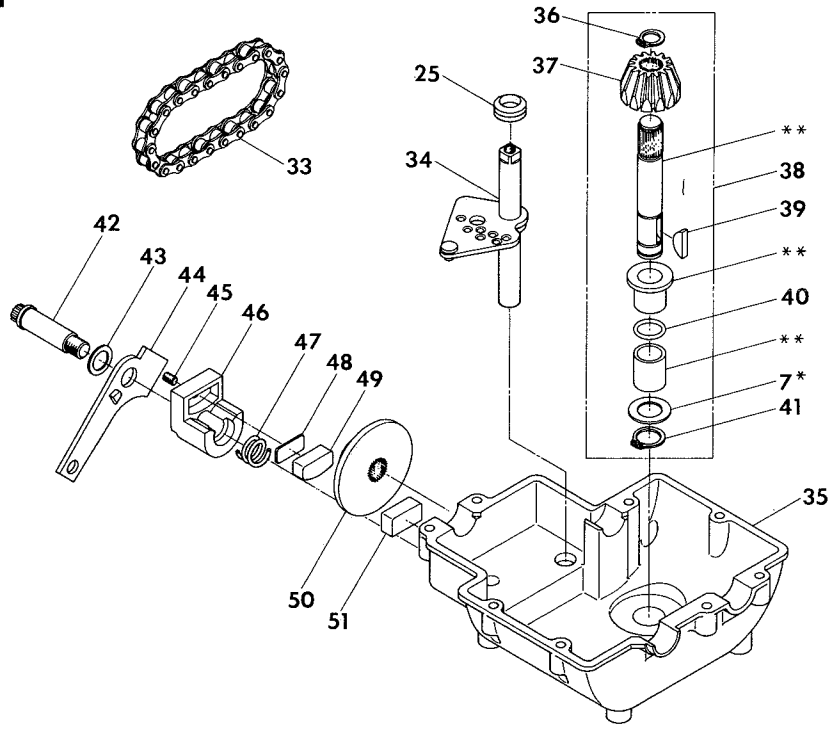

KEY NO.	FOOTE PART NO.	NO. REQ'D.	DESCRIPTION	TRANSMISSION MODELS PARTS USED ON	KEY NO.	FOOTE PART NO.	NO. REQ'D.	DESCRIPTION	TRANSMISSION MODELS PARTS USED ON
1	3665-C	1	Housing, Upper	All Models	39	1374	1	Key, Woodruff #9	All Models
2	1037	2	Ball, Detent	All Models	40	1926	1	O-Ring	4100-8, 4100-10, 4100-12
3	3720	2	Spring, Detent	All Models	41	1099	1	Ring, Retaining	All Models
4	3239	2	Screw, Set, ¼-20 x .50	All Models	42	1477	1	Bolt, Shoulder	All Models
5	1919	8	Screw, Tapping, ¼-20 x .734	All Models	43	1546	1	Washer, Plain, .510 x .750 x .006	All Models
6	1101	4	Bearing, Flange	4100-8, 4100-10, 4100-12	44	2757	1	Ass'y., Lever, Actuating	4100-8, 4100-10, 4100-12
7	1082	*	Washer, Plain, .632 x 1.00 x .031	All Models	45	1606	1	Screw, Set, #8-32	4100-8, 4100-12,
7	1424	*	Washer, Plain, .632 x 1.00 x .036	All Models	45	3743	1	Screw, Set, #10-32	4100-10
7	1068	*	Washer, Plain, .632 x 1.00 x .041	All Models	46	2618	1	Ass'y., Jaw, Brake	4100-8, 4100-12,
7	1425	*	Washer, Plain, .632 x 1.00 x .046	All Models	46	4181	1	Ass'y., Jaw, Brake	4100-10
7	1358	*	Washer, Plain, .632 x 1.00 x .050	All Models	47	1479	1	Spring, Compression	All Models
7	1145	*	Washer, Plain, .632 x 1.00 x .060	All Models	48	3293	1	Spacer	All Models
7	1319	*	Washer, Plain, .632 x 1.00 x .082	All Models	49	3242	1	Puck, Friction	All Models
8	3639	1	Gear, Bevel, 42 T.	All Models	50	3660	1	Disc, Brake	All Models
9	3645	1	Sprocket, 9 T.	All Models	51	3404	1	Puck, Friction	All Models
10	3630	1	Spacer	All Models	52	4300	1	Grease	All Models
11	3646	1	Gear, Spur, 12 T.	4100-8, 4100-10					
11	3707	1	Gear, Spur, 15 T.	4100-12					
12	3637	1	Gear, Spur, 20 T.	All Models					
13	3719	1	Gear, Spur, 25 T.	All Models					
14	3648	1	Gear, Spur, 28 T.	All Models					
15	3683	1	Gear, Spur, 31 T.	4100-8, 4100-10, 4100-12					
16	3632	1	Shaft, Drive	All Models					
17	1145	1	Washer, Plain, .632 x 1.00 x .060	All Models					
18	3631	1	Collar, Clutch	All Models					
19	3676	2	Key, Clutch	All Models					
20	3635	1	Shaft, Output	All Models					
21	3627	1	Ring, Retaining	All Models					
22	3640	1	Sprocket, 18 T.	All Models					
23	3629	1	Spacer	All Models					
24	3786	1	Gear, Spur, 37 T.	4100-8, 4100-10					
24	3785	1	Gear, Spur, 35 T.	4100-12					
25	3789	1	V-Ring	All Models					
26	3784	1	Gear, Spur, 30 T.	All Models					
27	3783	1	Gear, Spur, 25 T.	All Models					
28	3782	1	Gear, Spur, 22 T.	All Models					
29	3741	1	Gear, Spur, 19 T.	4100-8, 4100-10, 4100-12					
30	3628	1	Washer, Plain, .640 x 1.37 x .061	All Models					
31	3650	1	Sprocket, 8 T.	All Models					
32	1300	1	Ring, Retaining	All Models					
33	3625	1	Chain, 24 Pitches	All Models					
34	4221	1	Ass'y., Shifter	4100-8, 4100-12,					
34	4146	1	Ass'y., Shifter	4100-10					
35	3664-E	1	Housing, Lower	4100-8, 4100-10, 4100-12,					
36	3624	1	Ring, Retaining	All Models					
37	3590	1	Pinion, Bevel, 14 T.	All Models					
38	4135	1	Ass'y., Kit, Input Shaft	4100-8, 4100-10, 4100-12					

\* Use in various combinations to maintain proper clearances

\*\* Order Key #38.