

the difference is subtle but significant

Everyone likes an obvious choice. And your choice will be obvious when you see the critical differences between Briggs & Stratton genuine parts and the "look-alike" imitations. Whether it's air filters, mufflers or starter ropes, the difference is quality that only genuine parts can consistently give.

Whether you buy, sell or replace parts, you should be aware of the differences. That's because the compromises made in the production of imitations have implications that can affect engine life and performance. You can see the differences - just ask your Briggs & Stratton source of supply for the publication: GENUINE VS. IMITATION

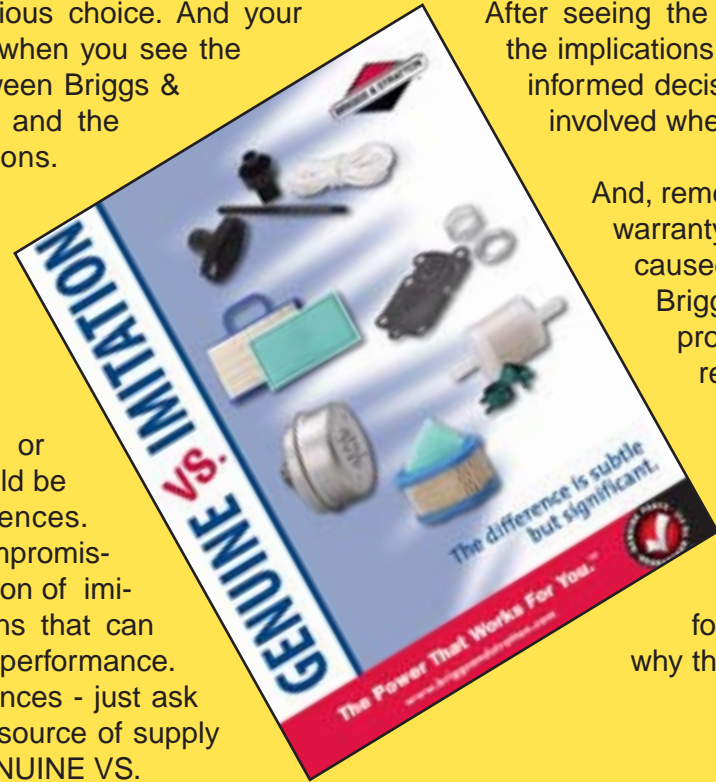

After seeing the differences and considering the implications, it will be easier to make an informed decision about the business risks involved when imitation parts are used.

And, remember that Briggs & Stratton warranty will not apply to failures caused by imitation parts, nor will Briggs & Stratton be liable for product liability claims that may result from damage caused by imitation parts.

Briggs & Stratton genuine parts are your only assurance of consistent quality, tested performance and value . . . That's why they are your obvious choice.



The Power That Works For You.™



GENUINE PARTS CATALOG



The Power That Works For You.™

www.briggsandstratton.com
www.briggsnetwork.com



Briggs & Stratton Corporation has been providing power for all people for almost a century now. In the outdoor power equipment industry, Briggs & Stratton is the number one producer of small engines, accounting for about two-thirds of the total market. With that kind of market penetration, a superior support network is necessary to provide customers with the excellent service they deserve.

The Briggs & Stratton Dealer Network provides this superior service and support. Our Dealers are the connecting human element between Briggs & Stratton and our end customers. With the increasingly important focus on the customer, we need to make certain our dealers are equipped with the necessary tools to meet and exceed our customers' expectations.

It is with this spirit and enthusiasm to provide the best service and support, that we present "The Briggs & Stratton Genuine Popular Parts Catalog." This catalog has been designed to assist users in locating the most popular parts in an efficient and time-saving manner. This latest revised edition is even more comprehensive, and includes some additional benefits to help you find exactly what you need...easily and quickly!

You'll find all the latest and greatest, including Briggs & Stratton's popular Red Box parts, Shop Packs, Tools, Accessories, Do It Yourself (DIY) Display Packed Parts, Co-branded Parts & Accessories and much more. In addition, we've added a new cross-reference parts matrix, making your parts selection even more user-friendly. (To locate the suggested list price of a part, refer to the Master Price List MS-7229.)

Briggs & Stratton Genuine Parts come with a ninety (90) day warranty. This protects our mutual customers from product defects which may result from defective material and/or workmanship. The Briggs & Stratton warranty does not apply to failures caused by the use of defective non-genuine merchandise. Only Briggs & Stratton Genuine Parts keep The Power in Power Equipment™. Don't settle for substitutes. Non-genuine replacement parts can adversely affect engine performance and in some instances, can result in costly premature engine failures.

Individuals who may be interested in acquiring information regarding the Briggs & Stratton Authorized Service Dealer "family," should contact their regional Briggs & Stratton Central Sales & Service Distributor (CSSD). The location of these CSSDs is shown on the map in the back of this catalog. CSSD representatives will explain the benefits and requirements of various Authorized Service Center programs. Authorized dealers can perform warranty repairs, participate in Factory Service Schools and Technical Update Seminars. Dealers and Registered Trade Accounts are eligible to receive regular mailings of Service Bulletins, Information Bulletins, Microfiche Updates and information pertinent to new products, along with advances being made in air cooled engine technology.

We hope you will use this catalog to its fullest extent and we welcome any suggestions you may have regarding its improvement. Please use the Improvement Suggestion Form, located in the back of this catalog, as a means of submitting your suggestions to Briggs & Stratton.

All of us at Briggs & Stratton wish you the best of luck in your business and future sales.

Please visit Briggs & Stratton at our Web Sites.

www.briggsandstratton.com

www.briggsnetwork.com

If you are an Authorized Briggs & Stratton Dealer, you may logon to our private extranet, www.briggsnetwork.com for a wealth of information exclusively available to our business partners.

Good Luck and Good Selling.



For possible exceptions and additional part numbers, please refer to Illustrated Parts Lists*, Service Tool Catalog MS-8746, Accessories Catalog MS-3880, Engine Sales Replacement Specifications and Price List MS-5568, and Master Price List MS-7299.



Accessories Catalog
MS-3880



Engine Sales Replacement
Specifications and Price List
MS-5568

405700 to 405799

*** REQUIRED SPECIAL TOOLS TO INSTALL - SEE REPAIR INSTRUCTION MANUAL ***

FIG. NO.	PART NO.	DESCRIPTION	FIG. NO.	PART NO.	DESCRIPTION	FIG. NO.	PART NO.	DESCRIPTION	
1	86023	Cylinder Assembly	20	460847	Oil Seal	239	460827	Oil Pressure Switch	
2	86026	Swallowhead Bolt (4x10mm 5x40)	22	690266	Screw	250	600953	Ignition Retainer	
3	439186	Oil Seal				252	600956	Oil Connector	
		(Ignition Retainer)				250	600957	Generator Cover	
4	600963	Engine Cover	60	600948	Intake Manifold		654	54076	Washer
5	600961	Breather Assembly	51A-51A-51A-51A	51A-51A-51A-51A	Intake Gasket	631	460962	Governor Shaft Seal	
6	427270	Breather Gasket	53	600951	Seal	216	239188	Loading Pin	
10	500906	Carburetor (Breather Assembly)	54	44619	Carburetor 1 Intake Manifold	1913	600954	Oil Filter Hopper	
11	600952	Breather Tube	112	600952	Carburetor-Selector	1917	600776	Oil Pump Screen	
12	427388	Oil Catcher Gasket				1919	600955	Locking Pin	
15	56225	Oil Drain Plug				1920	272624	Owner's Manual	
18A	600263	Oil Drain Plug							

10% LABEL KIT

10% OWNER'S MANUAL

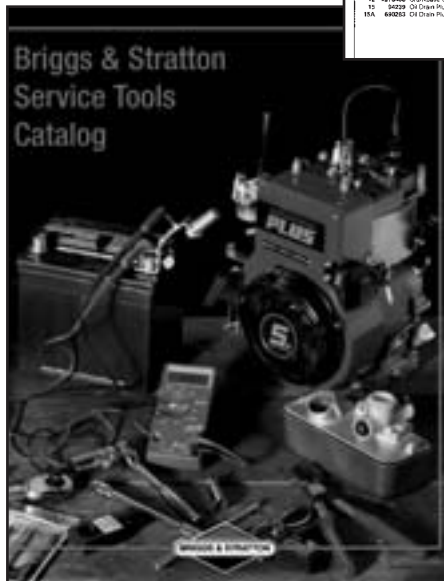

Service Tool Catalog
MS-8746

Illustrated Parts List*



Master Price List
MS-7299



<u>Books</u>	PART NUMBER
Tool catalog contains speciality service tools designed for repairing Briggs & Stratton gas & diesel engines. NOTE: Tool usage and tool part numbers are detailed in the repair manuals listed on page 2.	MS-8746
Service tips & tools a collection of helpful service tips and tools from dealers to aid in servicing engines.	CE8006
Small Engine Care & Repair a step by step guide to maintaining your small engine. 128 pages with over 300 color photos. Includes maintenance instructions, safe handling, troubleshooting, and many step by step pictures.	274041
“Small Engines” Textbook contains history of engine development, scientific principles of operation, troubleshooting, engine systems, engine applications, etc. Hardbound 332 pages.	CE8020
Major Engine Failure Analysis booklet , 47 pages packed with color photos showing a variety of engine failures and how to properly analyze each as to what caused the failure.	CE8034
“The Legend of Briggs & Stratton” 208 pages of historical data, time lines, and classic photos which take you from 1908 to the present market place. This hard bound book is a must for every collector and enthusiast.	MP-5160

<u>Repair Manuals</u>	PART NUMBER
4-Cycle single cylinder “L” head engine repair manual. “Our best seller” repair manual contains common specifications and detailed easy-to-follow instructions on how to adjust, tune up and repair most Briggs & Stratton 4-cycle single cylinder L-head engines. Used by Authorized Briggs & Stratton Service Centers. 350 pages.	270962
Vanguard™ repair manual for single cylinder overhead valve (OHV) engines.	272147
Intek™ repair manual for single cylinder overhead valve (OHV) engines.	274008
Twin cylinder “L” head engine repair manual. Similar to 270962, except covers Briggs & Stratton L-head twin cylinder engines.	271172
Vanguard repair manual for V-Twin overhead valve (OHV) engines. Model series 290400, 290700, 303400, 303700, 350400, 350700, 351400, 351700, 380400, 380700, etc.	272144
Intek™ repair manual for V-Twin overhead valve (OHV) engines. Model series 405700, 406700, 407700	273521
2-Cycle single cylinder lawn mower engine repair manual.	800100
2-Cycle single cylinder snow blower engine repair manual. Photo copies only.	
Antique repair manual , covers out of production engines built in years 1919-1981.	CE8069
3 Cylinder liquid cooled engine repair manual , covers gas and diesel engines and includes a binder. Model Series 430400, 432400, 437400, 522400, 580400, 582400.	MS-0729
CD-Rom Small gas engine repair manual , format for Windows 95, 98/NT. Covers maintenance and repair for all Briggs & Stratton 4-cycle gas engines (3.5 – 25 hp) manufactured after 1981.	CE3057

The icons used, next to each part, represent the packaging available for that part.

Example



Red Box (Most dealers stock)



Displayed on the Briggs & Stratton Profit Power Center or on a display wall



Shop Pack

Next to each icon is the part number of the packaged part.

Example:

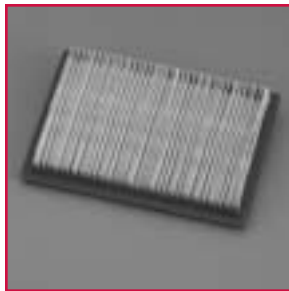

Air Filter Cartridge

3.5 & 4 HP Max Series & 2
cycle. *Uses 399039 Pre-Cleaner*



397795S



5027B



4102 Qty. 5

The air filter cartridge in the normal Red Box is part number 397795S.

It can also be ordered in the Display Package under part number 5027B.

It can also be ordered in the Shop Pack under part number 4102 with a quantity of 5 filters in the box.

The part number in bold type indicates the part shown in the photograph.

One or two icons next to the photo indicate this is the only packaging available.

If you would like to see a photograph of a Display Packaged part, refer to Accessories section pages 11-1 to 11-16 in this catalog.

Introduction	i
Reference Statement	ii
Speciality Publications	iii
Legend	iv
Table of Contents	v
Carburetion	1-1
Air Filters – Foam.....	1-1
Air Filters – Cartridge.....	1-2
Air Filters – Pre-Cleaners	1-6
Diaphragms.....	1-8
Float Valves.....	1-9
Fuel Pipes & Primer Bulbs	1-10
Needle Valves.....	1-11
Overhaul Kits – Carburetor	1-12
Compression	2-1
Piston Ring Set – Standard & Chrome	2-1
Intake and Exhaust Valves	2-2
Exhaust Systems	3-1
Mufflers.....	3-1
Mufflers – Vanguard™	3-5
Muffler Deflectors & Spark Arrestors	3-6
Fuel Systems	4-1
Fuel Filters – Line Clamps.....	4-1
Fuel Lines – Shut Off Valve.....	4-2
Fuel Tank Caps.....	4-3
Fuel Gauges	4-4
Ignition Systems	5-1
Armatures – Condensers – Breakers	5-1
Flywheel Keys – Ignition Parts.....	5-2
Spark Plugs.....	5-3
Spark Plug Elbows – Ignition Switches	5-4
Internal Parts	6-1
Connecting Rods.....	6-1
Air Cleaner Gaskets.....	6-3
Carburetor Bowl & Carburetor to Cylinder Gaskets	6-5
Carburetor to Cylinder Gaskets	6-6
Carburetor & Breather Gaskets	6-7
Engine Gasket Sets	6-8
Head Gaskets	6-10
Oil Guard Gasket & Valve Cover Gaskets	6-12
Valve Cover Gaskets & Valve Overhaul Gasket Sets	6-13

Lubrication	7-1
Oil Seals	7-1
Oil Filters & Miscellaneous	7-2
Starting Systems	8-1
Starter – Miscellaneous	8-1
Recoil Pulleys	8-2
Recoil Springs & Starter Clutches	8-3
Starter Grips	8-4
Starter Rope – Size, Usage, Comments	8-5
Water Cooled	9-1
3/LC Parts	9-1
3/LC Electrical Connectors	9-4
Tools	10-1
Kits*	10-1
Individual Tools*	10-3
Accessories	11-1
Maintenance Care Products	11-1
Counter Merchandisers	11-2
Display Packs	11-3
Cleaners, Grease, Fuel Stabilizer, Motor Oil & Lubricants	11-8
Briggs & Stratton Branded – Fuel Cans	11-10
Co-Branded – Cargo Management	11-11
Co-Branded – Battery Accessories	11-12
Generac Pressure Washer & Generator Accessories	11-14
Merchandising Solutions	11-16
Shop Packs Index	12-1
Genuine Parts Quick Reference	13-1
Reference Notes	13-50



Air Filter Foam Element
2-5 HP Horizontal

27987S 

5001B 

4108 Qty. 5 



Air Filter Foam Element
5 HP Vertical

 270447



Air Filter Foam Element
3 & 3.5 HP Vertical

270579S 

5009B 

4104 Qty. 5 



Air Filter Foam Element
7 & 8 HP Vertical

 270528S

 5045B

 4133 Qty. 4



Air Filter Foam Element
82500-92900 Series Vertical
w/Automatic Choke

270251 



Air Filter Foam Element
7-14 HP (Early Style)

 270093



Air Filter Foam Element
3-3.75 HP Vertical Classic™ &
Sprint™, 4 HP Quattro™

272235S 

5047B 

4107 Qty. 6 



Air Filter Foam Element
8-11 HP Vertical

 272922



Air Filter Foam Element
4 HP (10 CID) Vertical

270067 



Air Filter Foam Element
10 & 11 HP Vertical

 270843S

 5046B

 4134 Qty. 4



Air Filter Foam Element
4 HP Vertical

270848 



Air Filter Foam Element
Fource™

 696923



1-2 AIR FILTERS – CARTRIDGE – OVAL

CARBURETION

Air Filter Cartridge

10-12 HP Vertical,
Uses 271962S Pre-cleaner

399806S 

5048B w/271962S
Pre-cleaner 

4138 Qty. 4 



Air Filter Cartridge

7 & 8 HP Vertical

393406 



Air Filter Cartridge

11 HP Vertical

393725 

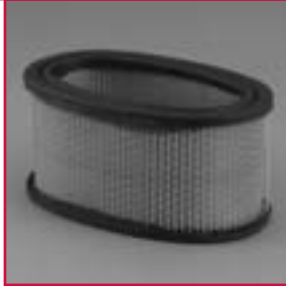

Air Filter Cartridge

7, 8 & 11 HP Horizontal,
Uses 271939 Pre-cleaner

399968 



Air Filter Cartridge

12.5 & 14 HP (26 CID)
Vertical Vanguard™,
Uses 492947 or 272444 Pre-cleaner

491021 



Air Filter Cartridge

8.5, 10.5 & 11 HP Vertical,
Uses 272477S Pre-cleaner

691667 



Air Filter Cartridge

12.5-15 HP Vertical,
Uses 272403S Pre-cleaner

496894S 

5053B w/272403S
Pre-cleaner 

4139 Qty.4 



Air Filter Cartridge

5.5 HP (10 CID) Vertical Vanguard™,
Uses 272218 Pre-cleaner

491950 





 4140 Qty. 5

Air Filter Cartridge

L-Head Twin Vertical,
Uses 272490S Pre-cleaner

394019S 

5052B w/272490S
Pre-cleaner 

4136 Qty. 4 



Air Filter Cartridge

Intek™, Model Series 121600, 122600
OHV, Uses 273356S Pre-cleaner

690610 

 5059B w/273356S
Pre-cleaner

 4196 Qty. 4

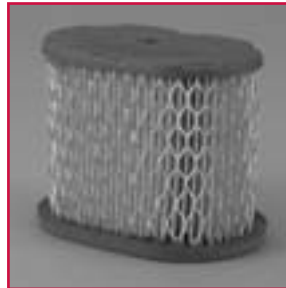

Air Filter Cartridge

Europa™ (9 CID) OHV Vertical,
Uses 273185S Pre-cleaner
Quantum®, 12U, 12V, 12W800

49725S 



4197 Qty. 4 



Air Filter Cartridge
2-5 HP Horizontal & Vertical,
Uses 271466 Pre-cleaner

392308S 



Air Filter Cartridge
7 & 8 HP Horizontal
(Early Style)

390492 



Air Filter Cartridge
2-5 Horizontal & Vertical
Uses 271466 Pre-cleaner

396424S 

5026B 

4137 Qty. 4 



Air Filter Cartridge
7 & 8 HP Horizontal
(Early Style)

390492 



Air Filter Cartridge
6 HP (14 CID) Vertical &
Horizontal

496047 



Air Filter Cartridge
10, 11 & 12 HP Horizontal

392286 



Air Filter Cartridge
L-Head Twin Horizontal & V-Twin Vanguard™,
Uses 272490S Pre-cleaner

394018S 

5050B w/272490S
Pre-cleaner 

4135 Qty. 4 

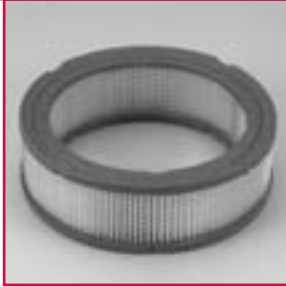

Air Filter Cartridge
7-18 HP Horizontal,
Uses 271794S Pre-cleaner

393957S 

 4106 Qty. 4



Air Filter Cartridge
3 LC

820263 



1-4 AIR FILTERS – CARTRIDGE – FLAT

CARBURETION

Air Filter Cartridge

3.5 & 4 HP Max Series & 2-Cycle, Uses 399039 Pre-cleaner

397795S 

5027B 

4102 Qty. 5 

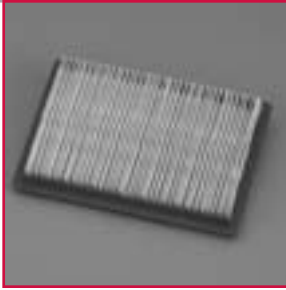

Air Filter Cartridge

9 HP (18 CID) Vanguard™ & (23 & 24 CID) Vanguard™

710266 

5074A 

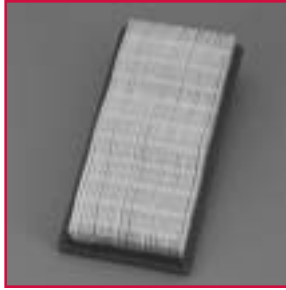

Air Filter Cartridge

3-5 HP Horizontal, 3.5-6 HP (12 CID) Quantum® & 6 HP (13 CID) Vertical, Uses 491435S or 493537S Pre-cleaner

491588S 

5043B 

4101 Qty. 4 

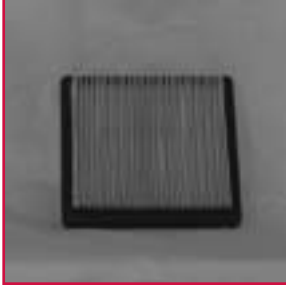

Air Filter Cartridge

7, 8 & 10 HP Horizontal, Uses 492889 Pre-Cleaner

691643 

5073A 

4195 Qty. 5 

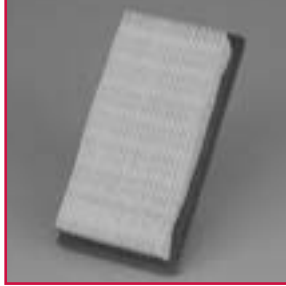

Air Filter Cartridge

3.5 HP Quantum® (10 CID)

399877S 

5028B 

4103 Qty. 5 

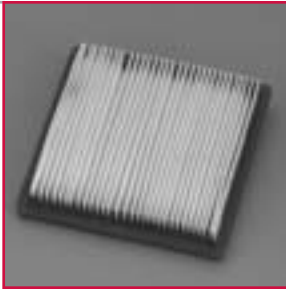

Air Filter Cartridge

12.5-16 HP Horizontal & Vertical V-Twin Vanguard™ Uses 805267 Pre-cleaner

805113 

4140 Qty. 5 

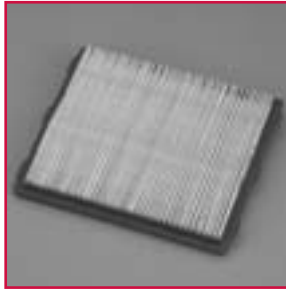

Air Filter Cartridge

3.5 & 5 HP Industrial Plus™

494511S 

5060B w/492889 Pre-cleaner 

4145 Qty. 4 

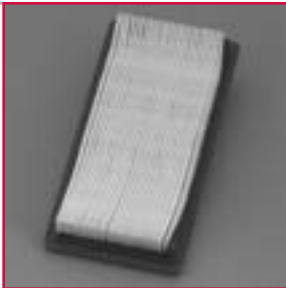

Air Filter Cartridge

Intek™ V-Twins, Uses 273638S Pre-cleaner; For Extended Life Version, Use 695091/5069B

499486S 

5063B 

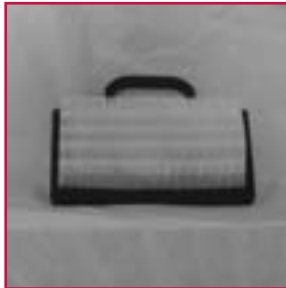

Air Filter Cartridge

4 HP (8 CID) Vanguard™

710265 

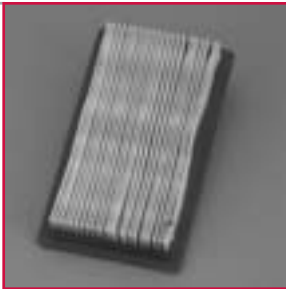

Premium Air Filter Cartridge ELS

Extended Life Version of 499486S/5063B

695091 

5069B 

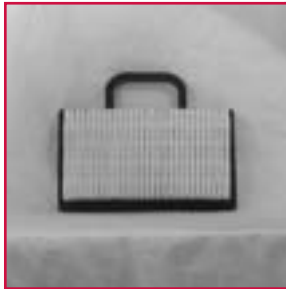

Air Filter Cartridge

9 HP (16 CID) Vanguard™ Uses 492889 Pre-cleaner

491384 

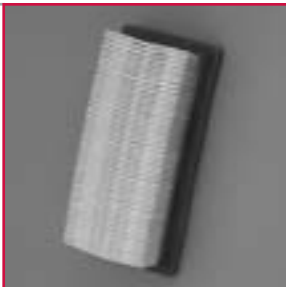

Premium Air Filter Cartridge ELS

697153 

5078D 



**Air Filter Cartridge
AVS**

Uses 697015 Pre-cleaner

697014 

5077D 



Air Filter Cartridge

Uses 697292 Pre-cleaner













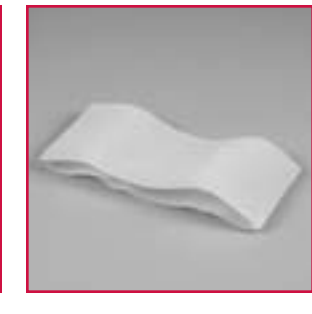









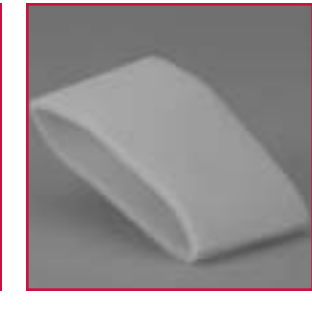



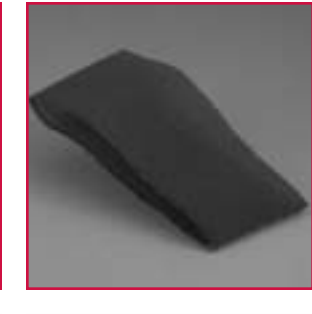

697152 

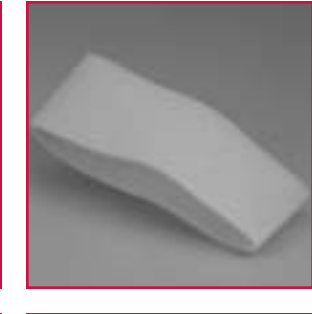
5079D 



1-6 AIR FILTERS - PRE-CLEANERS

CARBURETION

<p>Pre-cleaner Pre-cleaner for 497725S</p> <p>273185S </p>			<p>Pre-cleaner Pre-cleaner for 491021</p> <p> 492947</p>
<p>Pre-cleaner Pre-cleaner for 396424S & 392308S</p> <p>271466 </p> <p>4109 Qty. 4 </p>			<p>Pre-cleaner Pre-cleaner (Heavy Duty) for 491021</p> <p> 272444</p>
<p>Pre-cleaner Pre-cleaner for 393957</p> <p>271794S </p> <p>4141 Qty. 5 </p>			<p>Pre-cleaner Pre-cleaner for 697029</p> <p> 273356S</p>
<p>Pre-cleaner Pre-cleaner for 394019S & 394018S</p> <p>272490S </p> <p>4111 Qty. 6 </p>			<p>Pre-cleaner Pre-cleaner for 491950</p> <p> 272218</p>
<p>Pre-cleaner Pre-cleaner for 399968</p> <p>271939 </p>			<p>Pre-cleaner Pre-cleaner for 691667</p> <p> 272477S</p>
<p>Pre-cleaner Pre-cleaner for 399806S</p> <p>271962S </p> <p>4110 Qty. 4 </p>			<p>Pre-cleaner Pre-cleaner for 496894S</p> <p> 272403S</p> <p> 4142 Qty. 5</p>



Pre-cleaner
Pre-cleaner for 499486S
Intek™ V-Twin

273638S 



Pre-cleaner
Pre-cleaner for 710266

710268 



Pre-cleaner
Pre-cleaner for 491588S

491435S 

4146 Qty. 5 



Pre-cleaner
Pre-cleaner for 805113

805267S 

 4143 Qty. 5



Pre-cleaner
Pre-cleaner for 397795S

399039 



Pre-cleaner
Pre-cleaner for 697634

697015 



Pre-cleaner
Pre-cleaner for 491384

492889 

4148 Qty. 5 



Pre-cleaner
Pre-cleaner for 697152

697292 



Pre-cleaner
Pre-cleaner for 491588S
Selected Models

493537S 

5064A 

4147 Qty. 5 



Pre-cleaner
Pre-cleaner for 710265

710267 



1-8 DIAPHRAGMS

Diaphragm
3.5 & 4 HP Vertical
(Pulsa Jet Carburetor)
391681 



Diaphragm
3 HP Vertical
(Vacu-Jet Carburetor)
 299637



Diaphragm
All L-Head Twins & Selected 8 &
11 HP Horizontal (Fuel Pump)
272638S 





Diaphragm
3-3.75 HP Vertical
(Pulsa Prime Carburetor)
 495770

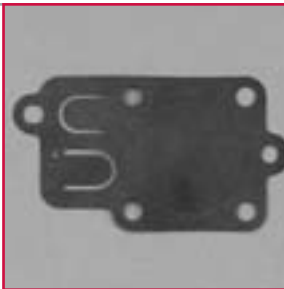

Diaphragm
3-5 HP Horizontal
(Pulsa Jet Carburetor/Old style)
270026 



Diaphragm
3-5 HP Horizontal
(Pulsa Jet) New Style
 272538S
 5021B



Float Valve
430400 & 580400

820486 



Float Valve
7-18 HP Horizontal & Vertical
(Brass Seat/Fuel Pump Equipped)

 394683

Float Valve
437400 & 587400

820506 



Float Valve
7-18 HP Horizontal & Vertical
(Viton Rubber Seat)

 394681

Float Valve
3 & 5 HP Horizontal
(Up-draft Carburetor)

293478 



Float Valve
8-12.5 HP Vertical

 494788

Float Valve
4 HP (8 CID) Vanguard™

715075 



Float Valve
9 HP (18 CID) Vanguard™
OHV Horizontal

 715155

Float Valve
All Max, Quantum®, 5 & 6 HP
Vertical, and 3.5 & 5 Industrial Plus™

398188 

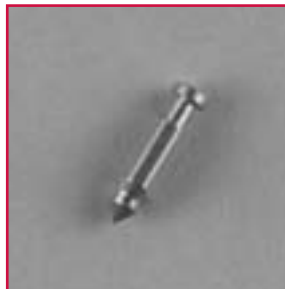
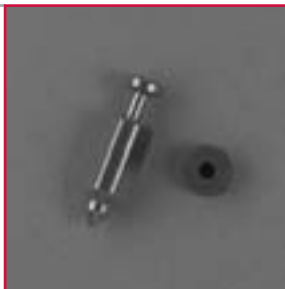

Float Valve
10, 10.5, 11.5, 12.5, 13, 14 &
15 HP (28 CID) Vertical

 231855S

Float Valve
7-18 HP Horizontal & Vertical
(Brass Seat)

394682 





1-10 FUEL PIPES & PRIMER BULBS

CARBURETION

Tube Pick-Up
4 HP Vertical (Vacu-Jet & Pulsa
Jet Carburetors)
297219S 



Intake Elbow Seal
3-6 HP Vertical
 **270344S**

Tube Pick-Up
3-3.75 Vertical
(Pulsa Prime Carburetor)
496046S 



Primer Bulb
Selected Models (12 CID)
(Backing Plate Mount)
 **694395**

Tube Pick-Up
3-5 HP Horizontal & 5 HP
Vertical (Pulsa Jet Carburetor)
391813 



Primer Bulb
Selected Quantum®
(12 CID)(Fuel Tank Mounted)
 **394281S**

Tube Pick-Up
3-5 HP Horizontal & Vertical
(Pulsa Jet Carburetor)
497413S 



Primer Bulb
Pulsa Prime Carburetor
 **694394**

Needle Valve
2 & 3 HP Horizontal
(Vacu-Jet Carburetor)

299059 



Needle Valve
4 HP (8 CID) Vanguard™,
5.5 HP (11 CID) & 9 (18 CID)

715293 



Needle Valve
3-4 HP Vertical
(Vacu-Jet & Pulsa Jet Carburetors)

395508 



Needle Valve
7-16 HP Horizontal & Vertical
(Float Carburetor)

995255 



Needle Valve
3.5 & 4 HP Max Series &
Quantum® (10 CID)

398157 



Needle Valve
7-18 HP Horizontal & Vertical
(Float Carburetor)

292681 



Needle Valve
3.5 & 4 HP Max Series &
Quantum® (10 CID)

492500 



Needle Valve
10, 10.5 & 11.5 HP (28 CID)
OHV Vertical

496589 



Needle Valve
3.5 & 4 HP Max Series, All Quantum®,
5 & 6 HP Vertical (Float Carburetor)

493765 



Needle Valve
11.5, 12.5 & 13 HP (28 CID)
Vertical

494383 



Needle Valve
3-5 HP Horizontal & Vertical
(Pulsa Jet Carburetor)

299060 



Needle Valve
13, 14 & 15 HP (28 CID)
Vertical

495932 



CARBURETION



1-12 OVERHAUL KITS – CARBURETOR

CARBURETION

Carburetor & Tank Kit
Used to Convert All 9 CID
Air Vane Governor L-Head Engines
to Primer-Type Carburetor

495912 



Overhaul Kit
3.5 & 4 HP Max Series &
All Quantum® & 5 HP
Industrial Plus™

 498260

Overhaul Kit
2 & 3 HP Horizontal
(Float Carburetor)

291691 

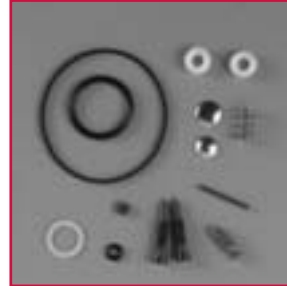

Overhaul Kit
3.5 & 4 HP Max Series,
Quantum® (10 CID) & 5-6 HP
Verticals (Float Carburetor)

 494349

Overhaul Kit
2 & 3 HP Horizontal
(Float Carburetor)

398992 



Overhaul Kit
3-5 HP Horizontal
(Pulsa Jet Carburetor)

 495606

Overhaul Kit
3-3.5 HP Vertical
(Vacu-Jet Carburetor)

494622 



Overhaul Kit
5 HP Vertical
(Pulsa Jet Carburetor)

 494625

Overhaul Kit
3-4 HP Vertical
(Pulsa Jet Carburetor)

494623 



Overhaul Kit
5.5 HP Vanguard™ OHV
Horizontal

 715439

Overhaul Kit
3.5-4 HP Vertical (Pulsa Jet
Carburetor) Tank Repair Kit

4184 



Overhaul Kit
6 HP Vanguard™ OHV
Horizontal

 715437



OVERHAUL KITS – CARBURETOR 1-13

CARBURETION

Overhaul Kit
7-8 HP Horizontal
(Up-draft After Code 84100800)

398235 



Overhaul Kit
11 & 13 HP Vanguard™
OHV Horizontal

 715387



Overhaul Kit
7-9 HP Horizontal
(Up-draft Float Carburetor)

394693 



Overhaul Kit
13, 14 & 15 HP
(28 CID) Vertical

 497535

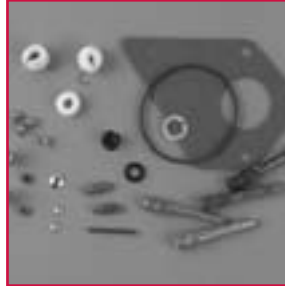

Overhaul Kit
7-12 HP Vertical
(Float Carburetor)

394698 



Overhaul Kit
16 HP (30 CID) Horizontal
V-Twin Vanguard™

 809021



Overhaul Kit
10, 11 & 16 HP Horizontal
(Single Cylinder, Current Style)

394989 



Overhaul Kit
18 HP (35 CID) Horizontal
V-Twin Vanguard™

 808083



Overhaul Kit
10-12 & 16 HP Horizontal
(Single Cylinder, Early Style)

391071 



Overhaul Kit
20 HP V-Twin Vanguard™
Horizontal

 808279



Overhaul Kit
10, 10.5 & 11.5 HP
(28 CID) Vertical

497481 

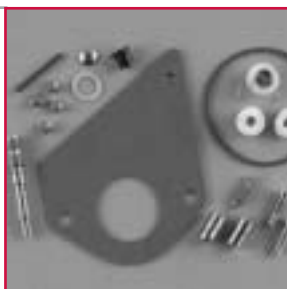

Overhaul Kit
All L-Head Twins

 694056



1-14 OVERHAUL KITS – CARBURETOR

CARBURETION

Overhaul Kit
Standard Choke
430400, 580400
825238 

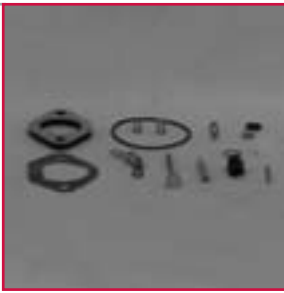

Overhaul Kit
Auto-Choke
430400
825258 



Overhaul Kit
437400
825438 



Overhaul Kit
587400
825441 

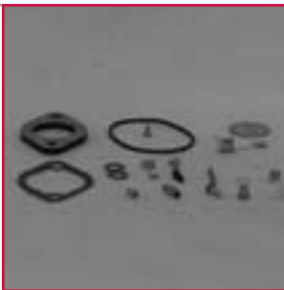

Overhaul Kit
6 HP Intek™
695157 

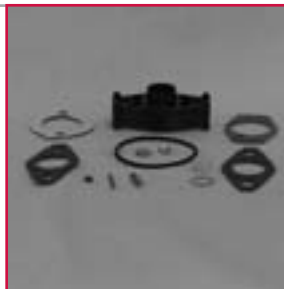



Horsepower	Crankshaft Direction	Engine Description	Ring Set Part Number
		Fource™	696933
2 & 3	Horizontal	L-Head	294232
3.5 & 3.75	Horizontal/Vertical	L-Head	498680
3, 3.75 & 5	Horizontal/Vertical	L-Head-Aluminum Bore	298982
5.0	Horizontal	L-Head Industrial Plus™	399067
5.0	Horizontal	L-Head-Cast Iron Bore	399067
6	Horizontal	Intek™	499631
8.0	Horizontal	L-Head Cast Iron Bore	690014
9.0	Horizontal	L-Head Industrial Plus™	690014
7 & 8	Horizontal/Vertical	L-Head-Aluminum Bore	499921
13.0	Vertical	L-Head Cast Iron Bore	499996
13.5	Vertical	L-Head Cast Iron Bore	499996
Quantum® (12 CID)	Vertical	L-Head-Aluminum Bore	493261
Europa™ (9 CID)	Vertical	L-Head-Aluminum Bore	493782
17	Vertical	L-Head Twin Opposed	394959
20.0	Vertical	L-Head-Cast Iron Bore	394959
10 & 11	Horizontal	L-Head-Industrial Plus™	495854
5.5, 6 & 6.5	Horizontal/Vertical	Intek™ OHV	499631
6.0	Vertical	Intek™ OHV	499425
13, 14 & 15 (28 CID)	Vertical	Intek™ OHV	495854
15.5	Vertical	Intek™ OHV	495854
16.5 & 17	Vertical	Intek™ OHV V-Twin	690162
18.0	Vertical	Intek™ OHV V-Twin	499604
4.5 (8 CID)	Horizontal	OHV Vanguard™	715060
5.5 (11 CID)	Horizontal	OHV Vanguard™	715016
7.5	Horizontal	OHV Vanguard™	715452
9 (18 CID)	Horizontal	OHV Vanguard™	715111
11 & 13	Horizontal	OHV Vanguard™	715346
12.5 -16	Horizontal/Vertical	OHV Vanguard™ - V-Twin	807620
18 & 20	Horizontal/Vertical	OHV Vanguard™ - V-Twin	807889
20 & 22	Vertical	OHV Vanguard™ - V-Twin	499604
22	Vertical	OHV Vanguard™ - V-Twin	808528
23	Horizontal	OHV Vanguard™ - V-Twin	808528
		587400, 580400 Gas	825036
		430400, 437400 Gas	825091
		432400, 522400 Diesel	825164
		582400 Diesel	825187

COMPRESSION

PISTON RING SET – CHROME



Horsepower	Crankshaft Direction	Engine Description	Ring Set Part Number
2 & 3	Horizontal	60000 & 80000 Series	297201
3, 3.75, 4 & 5	Horizontal/Vertical	90000, 10A900, 130000 Series	299742
	Horizontal/Vertical	110700, 1109, 1122, 1127, 1129, 1139, 1147, 1149 Series	392330
7 & 8	Horizontal/Vertical	1704, 1707, 171, 176, 19B,E,F,G; 190400, 190700, 191700	299743
8 & 9	Horizontal	204000	298746
10	Horizontal	243400	299744
11, 12 & 13	Horizontal	30 CID	299745
	Horizontal/Vertical	Model 22, 25, 28 Series	392331



2-2 INTAKE AND EXHAUST VALVES



Model Series /Horsepower	Crankshaft Direction	Engine Description	Part Number Intake Valve	Part Number Exhaust Valve
		Fource™	696864	696862
2 & 3.5	Horizontal/Vertical	L-Head	296677	296676
3.75	Horizontal	L-Head	296677	296676
5.0	Horizontal/Vertical	L-Head	261044S	211119S
Intek™ 6.0	Vertical	OHV	499641	499642
Quantum®	Vertical	12 CID	262652S	262651S
5.25, 6	Vertical	Quantum®	262652S	262651S
Quattro 4.0	Vertical	L-Head	296677	296676
5.0	Horizontal	Industrial Plus™	261044S	211119S
7 & 8.5	Horizontal/Vertical	L-Head	261055S	691794
8.0	Horizontal	L-Head	261055S	691287
9.0	Horizontal	L-Head Industrial Plus™	261055S	691794
10.0	Horizontal	L-Head	690429	691796
10, 10.5, 11.5, 12, 12.5 & 13	Vertical	L-Head - 28 CID	262247S	262246S
13.0	Vertical	L-Head	495857	495856
13.5	Vertical	L-Head	262247S	262246S
13, 14 & 15	Vertical	OHV - 28 CID	495857	495856
17.0	Vertical	L-Head Twin Opposed	691804	691794
20.0	Vertical	L-Head	691804	691794
Intek™ 5.5, 6	Horizontal/Vertical	OHV	499641	499642
Intek™ 15.5	Vertical	OHV	495857	495856
Intek™ 16.5	Vertical	OHV V-Twin	495857	495856
Intek™ 17, 18, 20, 22	Vertical	OHV V-Twin	495857	495856
85400	Horizontal	OHV-Vanguard™	715003	715002
104700	Vertical	OHV-Vanguard™	492769	492770
115400&117400	Horizontal	OHV-Vanguard™	715003	715002
138400 7.5 HP	Horizontal	OHV-Vanguard™	715446	715445
161400	Horizontal	OHV-Vanguard™	491911	491910
185400	Horizontal	OHV-Vanguard™	715754	715085
235400&245400	Horizontal	OHV-Vanguard™	715374	715373
260700&261700	Vertical	OHV-Vanguard™	492116	492117
290000&300000	Horizontal/Vertical	OHV-Vanguard™	807680 (2 used)	807681 (2 used)
350400&350700	Horizontal/Vertical	OHV-Vanguard™	807680 (2 used)	807681 (2 used)
351400&351700	Horizontal/Vertical	OHV-Vanguard™	807680 (2 used)	807681 (2 used)
351400, 351700	Horizontal/Vertical	OHV-Vanguard™ V-Twin	807680 (2 used)	807681 (2 used)
380400, 700, 381400	Horizontal/Vertical	OHV-Vanguard™ V-Twin	806420 (2 used)	806419 (2 used)
		3/LC Gas	820115 (3 used)	820114 (3 used)
		3/LC Diesel	820403 (3 used)	820404 (3 used)
445700			499597 (2 used)	499596 (2 used)

COMPRESSION

5/16" VALVE GUIDES L-HEAD ENGINES OVER 5 HP

Use Guide Numbers

Bushing removed from cylinder		Sintered Guide Gray or Copper Colored	261961
		Brass Guide 1 or 2 Grooves	231218
		Brass Guide No Grooves	230655
		Aluminum Guide or Cast Iron Cylinder	231218

1/4" VALVE GUIDES L-HEAD ENGINES 5 HP & UNDER

Use Guide Numbers

Bushing removed from cylinder		Sintered Guide Gray or Copper Colored	262001
		Brass Guide 1 or 2 Grooves	231348
		Brass Guide 1 or 2 Grooves	231349
		Brass Guide No Grooves	63709
		Aluminum Guide or Cast Iron Cylinder	63709



For valve guide part number(s) on OHV engines, consult Repair Instruction Handbook for respective engine(s).

Standard
2 & 3 HP Horizontal
(1/2" NPT)

89966 
5006B 



Muffler
6 HP Intek™

 693593



Standard
8-16 HP Horizontal Cast Iron
Models (1" NPT)

291519 



Standard
10-12 HP (8" Pipe Length)

 391569S



Standard
7 & 8 HP (3/4" NPT)

294599S 
5011B 



Lo-Tone
Selected Model 28 Verticals

 495805S



Lo-Tone
2-4 HP (11 CID) Horizontal
(1/2" NPT)

493288 



Super Lo-Tone
5 HP Horizontal

 496892



Lo-Tone
3-4 HP Vertical (1/2" NPT)

394569S 
5019B 



Standard
8-16 HP Horizontal/Cast Iron
Models (7" Pipe Length, 1" NPT)

 299477S



Standard
16 HP Horizontal/Cast Iron
Models (11" Pipe Length, 1" NPT)

393232S 



Standard
9-16 HP Single Cylinder
(Less Pipe Extension)

 392989



3-2 MUFFLERS

EXHAUST SYSTEMS

Super Lo-Tone
3-4 HP Vertical

692307 



Muffler
6 HP Intek™

 694429



Super Lo-Tone
All Quantum®

496106S 



Lo-Tone
5-8 HP Horizontal & Vertical
(3/4" NPT)

 393010S



Lo-Tone
2 Cycle (9 CID) for DIN Guard

802580 



Lo-Tone
7-8 HP Vertical

 691971



Lo-Tone
5.5 HP Quantum®

497681 



Super Lo-Tone
7 & 8 HP Horizontal &
Vertical

 494222



Lo-Tone
6 HP Quantum®

692038 



Super Lo-Tone
7 & 8 HP Horizontal Special
RAF Reduced Noise Design

 494221



Lo-Tone
2 Cycle (9 CID)

802500 



Super Lo-Tone
5 HP Horizontal Special RAF
Reduced Noise Design

 691969



Lo-Tone
5 HP Horizontal & Vertical

390918S 



Lo-Tone
10 & 11 HP Horizontal

497470 



Lo-Tone
5-8.5 HP Horizontal & Vertical

692304 



Lo-Tone
10 & 11 HP Horizontal Special
RAF Reduced Noise Design

491626 



Lo-Tone
9-18 HP Horizontal
Remote Mount

399635 



Lo-Tone
10-12.5 HP Horizontal & Vertical
Special RAF Reduced Noise Design

691874 



Lo-Tone
10 HP Horizontal

497966 



Lo-Tone
12 HP Vertical

490600 



Lo-Tone
Selected Model 28 Verticals

496022S 



Lo-Tone
4 HP (10 CID) 5 HP
Horizontal & Vertical

494585 



Lo-Tone
Quantum® (12 CID)

494343S 



3-4 MUFFLERS

EXHAUST SYSTEMS

Super Lo-Tone
3.5 HP Industrial Plus™

692365 



Super Lo-Tone
8 & 11 HP Horizontal,
18 HP Opposed Twin Horizontal
Selected Models OHV Twins - (Horizontal
& Vertical C/S Models (Remote Mount)
Special RAF Reduced Noise Design

498984S 



Super Lo-Tone
Europa™ (9 CID) OHV Vertical

494717 



Super Lo-Tone
3 & 4 HP (11 CID) Horizontal

691360 



Super Lo-Tone
Twin Cylinder Horizontal (L-Head)
Special RAF Reduced Noise Design

491307S 



Super Lo-Tone
Twin Cylinder Vertical (L-Head)
Special RAF Reduced Noise Design

491319S 



4 HP Vanguard™ OHV
Horizontal

715487 



Super Lo-Tone
12.5 & 14 HP (26 CID)
Vanguard™

 491692

Super Lo-Tone
5 HP (10 CID) Vanguard™

492746 



Super Lo-Tone
12.5 & 14 HP (26 CID)
Vanguard™

 491796

Lo-Tone
5.5 & 6 HP Vanguard™ OHV
Horizontal

715435 



Super Lo-Tone
12.5 & 14 HP (26 CID)
Vanguard™

 493626

Super Lo-Tone
9 HP (16 CID) Vanguard™
High Mount

493584 



Super Lo-Tone
All Horizontal V-Twin Vanguard™
High Mount (Oil Filter Side Outlet)

 807799

Super Lo-Tone
9 HP (16 CID) Vanguard™

491512 



Super Lo-Tone
All Horizontal V-Twin Vanguard™
High Mount (Starter Side Outlet)

 807831

Super Lo-Tone
12.5, 16 & 18 HP Vanguard™
V-Twin Horizontal

690931 



EXHAUST SYSTEMS







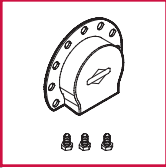
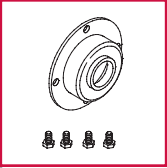
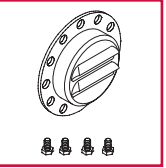
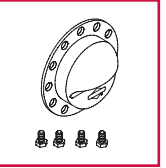
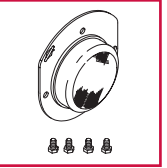























3-6 MUFFLER DEFLECTORS & SPARK ARRESTORS

The items listed below are for use on the engine series shown, when equipped with mufflers designed for use with either a deflector or spark arrester.

	Side Out	Direct Out	Louvered	Louvered	Spark Arrester
					
60000, 80000, 90000, 94200, 100000, 110000, 120000	393760	397931	None	396548	398067
93400	692010	None	None	None	690813
99700	None	None	None	None	493662
*85400, 115400, 117400, 138400, 185400, 110400	393757	None	None	None	715491
a130000, 170000, 190000	393757	395700	393758	None	399541
133400, 134400	692010	None	None	None	690813
250000, 311700	393761	396903	397630	None	392390
280000	393761	396903	397630	None	392390
400000, 420000	393761	396903	397630	None	392390
290000, 300000, 311700, 350000	393761	396903	397630	None	392390 & 808361

*Retainer required

<p>Fuel Filter 40 Micron (For Selected Engines with Fuel Pump, See-through)</p> <p>691035  5065B  4129 Qty.5 </p>			<p>Fuel Filter Fource™</p> <p> 696918</p>
<p>Fuel Filter 75 Micron (For Selected Engines with Fuel Pump)</p> <p>394358S  4112 Qty. 5 </p>			<p>Fuel Filter 3/LC Gas</p> <p> 692983</p>
<p>Fuel Filter 150 Micron (For Engines without Fuel Pump)</p> <p>298090S  5018B  4105 Qty. 5 </p>			<p>Premium Fuel Filter 30 Micron (For Selected Engines with Fuel Pump)</p> <p> 695666  5070D</p>
<p>Fuel Filter Vanguard™ V-Twins, Horizontal w/9 Quart Fuel Tank</p> <p>808116S </p>			<p>Fuel Line Clamp</p> <p> 691038 Black ID .460”  95162S Green ID .490”  710067 ID 13.2 MM  710075 ID 10.5 MM</p>
<p>Fuel Filter “In Tank” Strainer for 4, 5.5 & 9 HP Vanguard™</p> <p>710065 </p>			
<p>Fuel Filter Glass Sediment Bowl Fuel Filter Assembly</p> <p>690612 </p>			

4-2 FUEL LINES – SHUT OFF VALVE

Fuel Line Display Pack

Bulk 25' (1/2" OD x 1/4" ID)
Cut to Fit 499742 Refill for
Display Pack (25')

395051 



Fuel Shut-off Valve

In-Line Valve (Quantum® &
Selected Models)

 494768

Fuel Line

3.5 & 5 HP Industrial Plus™
(Molded)

495218 



Fuel Shut-off Valve

90 Degree Valve
3.5 HP & 5 HP Industrial Plus™

 494769

Fuel Line

4, 5.5 & 9 HP Vanguard™
(Tank to Shut-off Valve)
8 mm OD x 470 mm (18-1/2")
Cut to Fit

715125 



Fuel Shut-off Valve

4, 5.5 & 9 HP Vanguard™

 715027

Fuel Line

4, 5.5 & 9 HP Vanguard™
(Shut-off Valve to Tank)
4 mm OD x 220 mm (8-5/8")
Cut to Fit

715126 



Fuel Shut-off Valve

6 HP Intek™

 692586

Fuel Shut-off Valve

Selected Models

399517 



Tygon™ Bulk Fuel Line

 695540 3/32" ID, 50 ft.

 695541 1/8" ID, 50 ft.

 695542 .080" ID, 50 ft.

Fuel Shut-off Valve

5 HP Vertical OHV Vanguard™

492982 



Fuel Line

23" (1/2" OD x 1/4" ID)
Cut to Fit

 296004

Fuel Tank Cap
4-11 HP

394818S 



Fuel Tank Cap
3-5 HP Horizontal, 94200

 494559



Fuel Tank Cap
2 & 3 HP Horizontal &
Selected 5 HP

69221 



Fuel Tank Cap
3.5-6 HP Vertical Max,
Quantum® & Europa™

 397974S

 5044B

 4131 Qty. 5, 4149 Qty. 20



Fuel Tank Cap
135200 & 136200 Horizontal
Series/Selected Models

498156 



Fuel Tank Cap
4, 5.5 & 9 HP Vanguard™

 710490



Fuel Tank Cap
5-11 & 13 HP Horizontal

392305S 



Fuel Tank Cap
Intek™ Model Series
121600 Vertical

 692046



Fuel Tank Cap
10 HP Horizontal
(Sno Gard®)

297866S 



Fuel Tank Cap
OHV Vanguard™ (10 & 16 CID)
and V-Twins

 491367S



Fuel Tank Cap
2-4 HP Horizontal &
Vertical, Quattro™

493982S 



Fuel Tank Cap
7-12.5 HP Vertical, 3.5, 5 & 9 HP
Industrial Plus™, & 5.5 HP Intek™

 493988S



4167 



4-4 FUEL TANK CAPS – GAUGES

Fuel Tank Cap

2 Cycle (9 CID) 50:1 Mixture

800006 



Fuel Gauge

Engine Usage - 3.0, 3.5 & 4.0 HP.
Vertical Crankshaft - 1 quart metal tanks

 299992

Fuel Tank Cap

Fource™

696921 



Fuel Gauge

Quantum® (12 CID)

 494277

Fuel Tank Cap

6 HP Intek™

694261 



Fuel Tank Cap

134400 L-Head, Industrial Plus™
& 8 HP 197400, 110400,
121400, Intek™

493988S 



Fuel Tank Cap

3.5 & 3.75 HP Classic™ &
Sprint™ and 4 HP Quattro™

497929S 

5057B 

4132 Qty. 5, 4150 Qty. 20 



Armatures

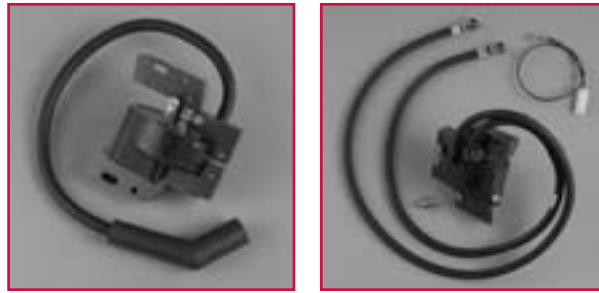

Engine Model	Style	Red Box #
2-4 HP Horizontal & Vertical	Breaker Points	298502
5 HP Horizontal & Vertical	Breaker Points	298316
7-16 HP Horizontal & Vertical Single Cylinder	Breaker Points	298968
L-Head Twins	Breaker Points	392329
2-4 HP Horizontal & Vertical	Magnetron	496914
Quantum (10CID)	Magnetron	490748
5 HP Horizontal & Vertical	Magnetron	397358
7-16 HP Horizontal & Vertical Single Cylinder	Magnetron	398811
13, 14 & 15 HP (28CID) OHV Vertical	Magnetron	492341
L-Head Twins	Magnetron	394891
2 Cycle, Quantum (12CID) & Europa (9CID)	Magnetron	802574
4, 5.5 & 6 HP Vanguard (8 & 11CID)	Magnetron	715023
5 HP Vanguard Vertical (10 CID)	Magnetron	802574
9 HP Vanguard (18CID)	Magnetron	715118
9, 12.5 & 14 HP Vanguard (V-Twin 2 used)	Magnetron	492341
10-13 HP (28CID) L-Head	Magnetron	492341
11 & 13 HP Vanguard Horizontal	Magnetron	715231
Fource	Magnetron	696877
6 HP Intek Vertical (12CID)	Magnetron	802574
5.5 - 6.5 HP Intek (11 & 12 CID)	Magnetron	692605
Vanguard V-Twin	Magnetron	492341
Intek V-Twin	Magnetron	691060
3/LC Ignition Coil (3 used)		820037

Condensers & Breakers

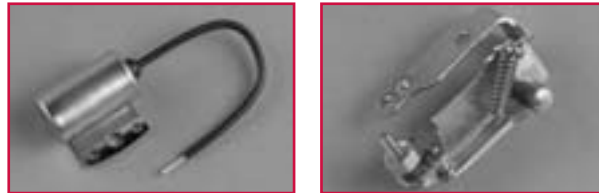

Engine Model	Condensers	Breakers
8-16 HP Horizontal Cast Iron Models	298060	298185
10 & 11 HP Horizontal & Vertical	29861	391284
Twin Cylinder L-Head Engines	392912	29818

Condenser & Breaker Assembly



Engine Model	Red Box #	DIY #
2-8 HP Horizontal & Vertical	294628	5012
2-8 HP Horizontal & Vertical (With Plug & Plunger)	299061	5020

5-2 FLYWHEEL KEYS – IGNITION PARTS

Ignition Point Plunger

All Twin Cylinder
L-Head Engines

393598 



Flywheel Key

4, 5.5, 6 & 9 HP Vanguard™

 710037

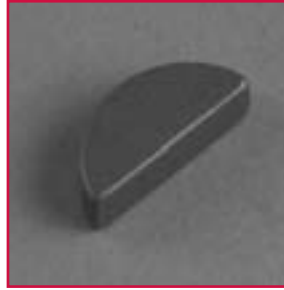

Ignition Point Plunger

2-11 HP Horizontal & Vertical

65704S 



Flywheel Key

2 Cycle (9 CID)

 800036

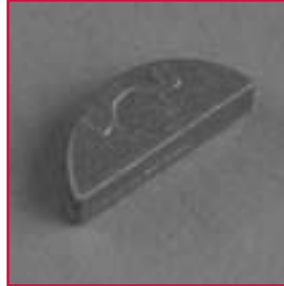

Ignition Point Plunger

9-16 HP Horizontal
Cast Iron Models

298125S 



Flywheel Key

All V-Twin Vanguard™

 808095

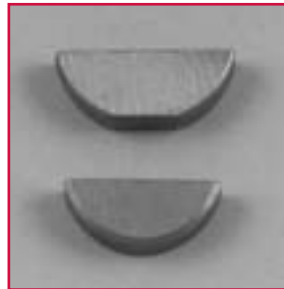

Ignition Cable Terminal

Selected Engines

493880S 

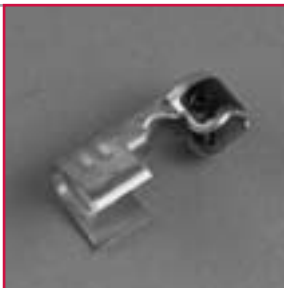

Flywheel Key

Most Engines

 222698S

 5002B Qty. 3

 4144 Qty. 50



Magnetron® Kit

Used to Retrofit Most 2
Legged Ignition Armatures
with Breaker Points

394970 



Breaker Assembly

10 & 11 HP Horizontal &
Vertical

 391284



RC14YC Spark Plug
Selected Engines

496018S 



RC12YC Spark Plug
Selected Engines
3 LC Gas

 491055S



J19LM Spark Plug
RJ19LM Spark Plug
selected engines
(Resistor Spark Plug 802592S)

492167S 



Spark Plug
Fource™

 696876



RJ19LM Spark Plug
Selected Engines

802592S 





QC12YC Spark Plug
Selected Engines

 691043



Spark Plug
Selected L-Head
Long Life Platinum

5062D 
4176 Qty. 8
4175 Qty. 24 



****Platinum Spark Plug Features & Benefits**

Two Platinum Spark Plugs are now available-5062B for L-Head and 5066B for OHV engines. They provide long life, easy starting, increased ignitability, reduced fouling & idle stability. They are resistorized for RFI protection.

Display package options include:

5062D Cut case tray of 18 plugs	5066D Cut case tray of 18 plugs
4176 Shop pack of 8	4174 Shop pack of 8
4175 Shop pack of 24	4173 Shop pack of 24

Spark Plug
Selected OHV
Long Life Platinum

5066D 
4174 Qty. 8
4173 Qty. 24 



5-4 SPARK PLUG ELBOWS – IGNITION SWITCHES

Spark Plug Elbow
Most Engines

66538S 

4124 Qty. 5 

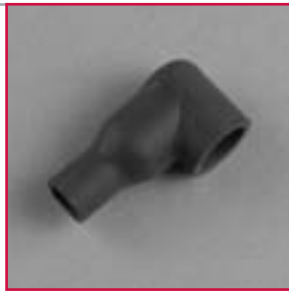

Spark Plug Boot
6 HP Intek™

 692927



Spark Plug Elbow
4, 5.5 & 9 HP Vanguard™

710634 



Stop Switch
Most Engines

 297472S

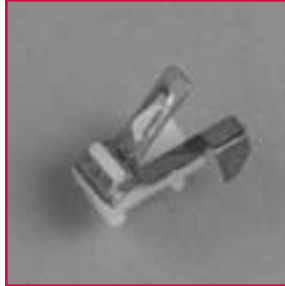

Spark Plug Elbow
3/LC Gas

820084 



IGNITION SYSTEMS

IGNITION SWITCHES:

Ref. No.	Part No.	Description
1	298590	Toggle switch
2	692303	Pushbutton starter switch
3	496590	Toggle switch
4	691959	Indak ignition keys (set of 2)
5	392833	Key switch for key 691959
6	692318	Key switch assembly - used on engines equipped with carburetor solenoid
7	693623	Rocker switch (with light) Note: Rocker switch without light is 692599
7a	495098S	Stop Switch
8	695747	Key switch used on selected snow engines
9	695756	Key used on selected snow engines
10	690646	Key switch
11	691959	Key Set for key switch 690646
12	695951	T-N-M Key

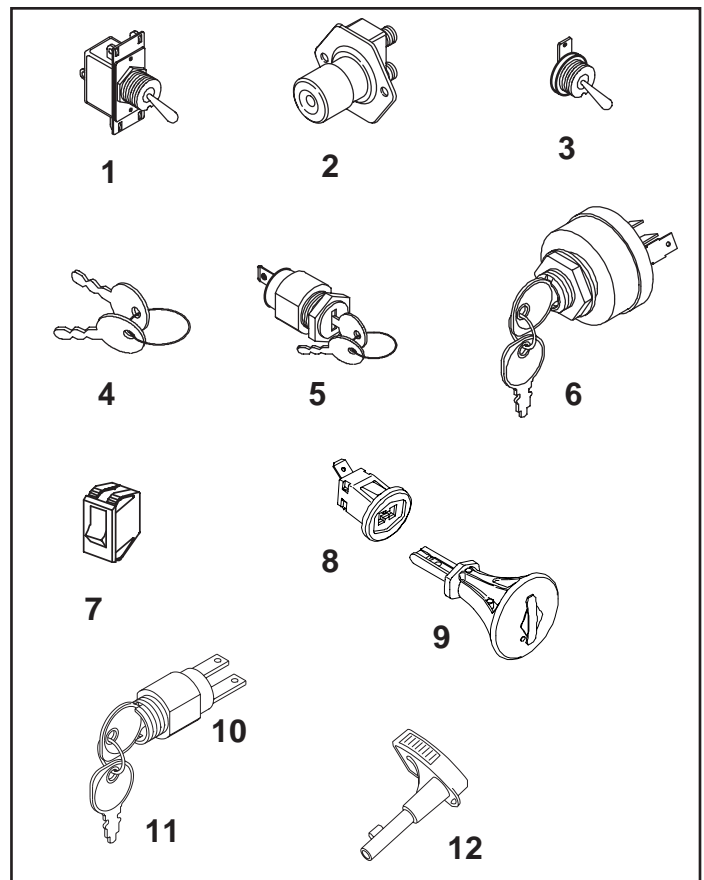

Connecting Rod
3-3.5 HP Horizontal

294367 



Connecting Rod
5.5 & 6 HP (11 CID)
Vanguard™

 715011



Connecting Rod
3-3.75 HP Vertical

294201 



Connecting Rod
8 HP Horizontal

 390401



Connecting Rod
3.5 & 4 HP Max Series, 3.5-6 HP
(12 CID) Quantum®, Prior to
97011300 Date Code

490566 



Connecting Rod
9 HP (18 CID) Vanguard™

 715106



Connecting Rod
4 HP (8 CID) Vanguard™

715055 



Connecting Rod
11-15 HP Horizontal & Vertical
Except OHV Models

 490348



Connecting Rod
4 HP Quattro™

496792S 



Connecting Rod
11 & 13 HP Horizontal Vanguard™
OHV Single Cylinder

 715345



Connecting Rod
5 HP Horizontal

299430 



Connecting Rod
13, 14 & 15 HP (28 CID)
OHV Vertical

 494504S



INTERNAL PARTS

6-2 CONNECTING RODS

Connecting Rod

17 HP Vertical Twin
Opposed

394306 



Connecting Rod

All Vanguard™ OHV V-Twins
(2 used)

807900S 



Connecting Rod

20 HP Vertical Opposed
Twin (2 used)

498314 



Connecting Rod

3/LC Gas

825033 



Connecting Rod

3/LC Diesel

825171 



















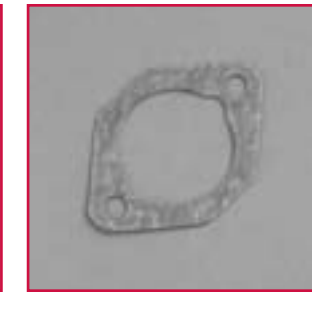



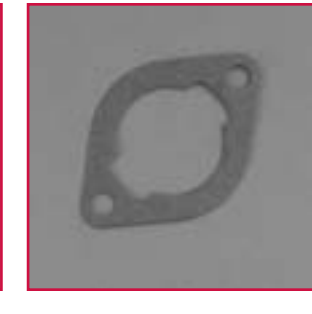

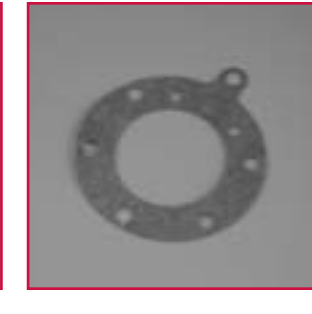

Connecting Rod

6 HP Intek™

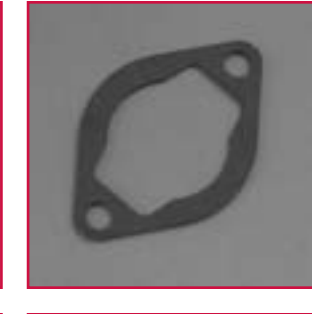
499424 



INTERNAL PARTS

<p>Air Cleaner Gasket 3.5 & 5 HP Industrial Plus™, 5 & 6 HP, 11&12 CID Intek™</p> <p>272948S </p>			<p>Air Cleaner Gasket 5.5 HP (11 CID) Vanguard™</p> <p> 710060</p>
<p>Air Cleaner Gasket Quantum® Series (12 CID) w/Primer</p> <p>272653S </p>			<p>Air Cleaner Gasket 9 HP (18 CID) Vanguard™</p> <p> 710235</p> <p> 4156</p>
<p>Air Cleaner Gasket 7 & 8 HP Horizontal</p> <p>27907 </p>			<p>Air Cleaner Gasket 11 & 13 HP Vanguard™ Horizontal</p> <p> 710557</p>
<p>Air Cleaner Gasket 7 & 8 HP Vertical</p> <p>270539 </p>			<p>Air Cleaner Gasket 17.0 HP Horizontal Twin Opposed Pressure Lube</p> <p> 690273</p>
<p>Air Cleaner Gasket 3-5 HP (Gasket Material)</p> <p>271139S </p>			<p>Air Cleaner Gasket 7-11 HP Horizontal w/Flat Pleated Air Filter</p> <p> 692277</p>
<p>Air Cleaner Gasket 4 HP (8 CID) Vanguard™</p> <p>710109 </p>			<p>Air Cleaner Gasket 6 HP Intek™ Flat Panel AC</p> <p> 272948</p>

6-4 AIR CLEANER GASKETS

Air Cleaner Gasket
2-5 HP Horizontal

27660 



Air Cleaner Gasket
6 HP Intek™
High Mount A/C

 693458



Air Cleaner Gasket
2-5 HP

271755 



Air Cleaner Gasket
Fource™

 696867



Air Cleaner Gasket
2-5 HP Horizontal

271935S 



Air Cleaner Gasket
3-5 HP (Rubber Material)

271077 



Air Cleaner Gasket
3-5 HP (Gasket Material)

271139S 



Air Cleaner Gasket
3.5 & 4 HP Max &
Quantum® Series w/Choke

272296 





INTERNAL PARTS



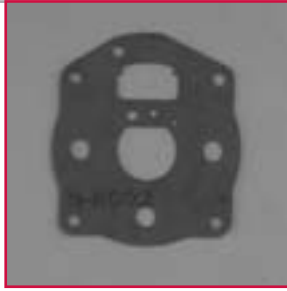

Carburetor Bowl Gasket
 20 HP Opposed Twin
 After Code Date 96102000
273186S 

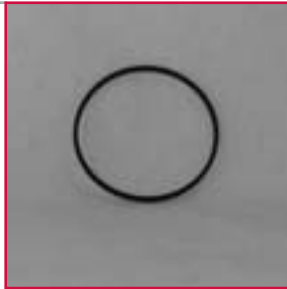

Carburetor to Cylinder
 4 HP (11 CID) Vertical
 **270844**

Carburetor Bowl Gasket
 6 HP Intek™
693981 



Carburetor to Cylinder
 3.5 & 5.5 HP Horizontal, 94200
 Series (Including 136200 Series)
 **273113S**

Carburetor Bowl Gasket
 Quantum® (12 CID)
 (Carburetor Bowl & Gasket Kit)
493640 



Carburetor to Cylinder
 10 & 11 HP Horizontal
 **498869**

Carburetor Bowl Gasket
 5 HP Vertical OHV
 Vanguard™
272188 



Carburetor to Cylinder
 3 & 3.5 HP Horizontal
 **270345S**

Carburetor Bowl Gasket
 7-11 HP Horizontal w/Bowl Type
 Carburetor and 8-13 HP Vertical
 w/Bowl Type Carburetor
281165S 



Carburetor to Cylinder
 13, 14 & 15 HP (28 CID) Vertical
 **272569S**

Carburetor Bowl Gasket
 7-12 HP Vertical
270511 



Carburetor to Cylinder
 2-5 HP Horizontal
 **27355S**

6-6 CARBURETOR TO CYLINDER GASKETS

INTERNAL PARTS

Carburetor to Cylinder
7 & 8 HP Horizontal

27828S 



Carburetor to Cylinder
4-6 HP Vanguard™
(8 & 11 CID)

 710060



Carburetor to Cylinder
Quantum® (12 CID)

272199S 



Carburetor to Cylinder
9 HP (18 CID) Vanguard™

 710237



Carburetor to Cylinder
7, 8, 10, 10.5, 11.5, 12.5 &
13 HP Horizontal & Vertical

272554S 



Carburetor to Cylinder
11 & 13 HP Vanguard™
Horizontal (2 used)

 710559



Carburetor to Cylinder
9-16 HP Horizontal Cast Iron

27381S 



Carburetor to Cylinder
460700 Series Twin
Opposed

 692278



Carburetor to Cylinder
6 HP Intek™

692555 



Carburetor to Cylinder Gasket
Fource™

 696868



Choke Link Cover
3-4 HP Vertical

270571 



Carburetor to Gas Tank
94200 Series

 692241



Carburetor to Gas Tank
2 & 3 HP Horizontal
(Vacu-Jet)

27404 

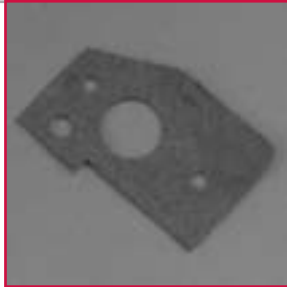

Carburetor to Intake
3/LC Gas
430400, 580400

 820160



Carburetor to Gas Tank
3-3.75 HP Vertical (Pulsa Prime)
Gasket w/Diaphragm

495770 



Carburetor to Intake
3/LC Gas
437400, 587400

 820385

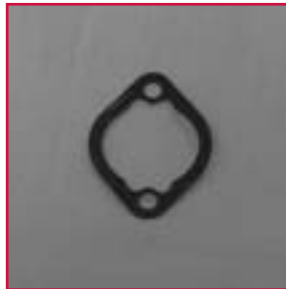

Carburetor to Gas Tank
3-5 HP Horizontal
(Pulsa-Jet)

272996 



Breather Gasket
7-2 HP L-Head
Horizontal & Vertical

 27893S

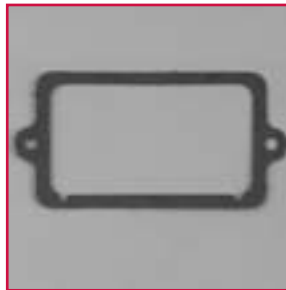

Carburetor to Gas Tank
3-5 HP Horizontal
(Pulsa-Jet)

272409S 

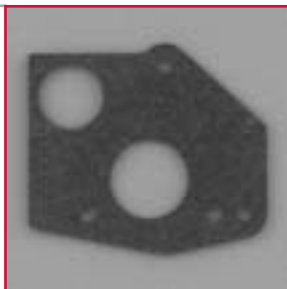

Breather Gasket
2-5 HP Horizontal

 27549S

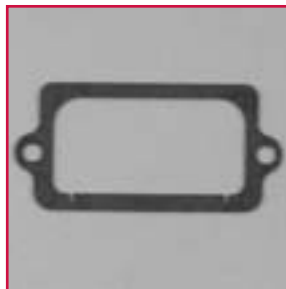

4123 Qty. 5 

Carburetor to Gas Tank
5 HP Vertical (Pulsa-Jet)

270073 



Breather Gasket
3-4 HP Vertical

 695890



6-8 ENGINE GASKET SETS

INTERNAL PARTS

Gasket Set
7 & 8 HP Horizontal & Vertical

299577 

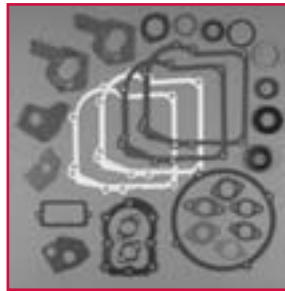
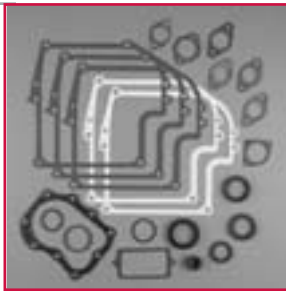

Gasket Set
2-3.5 HP Vertical

 495602

Gasket Set
10, 10.5, 11.5, 12.5 & 13 HP
(28 CID) Vertical

494241 

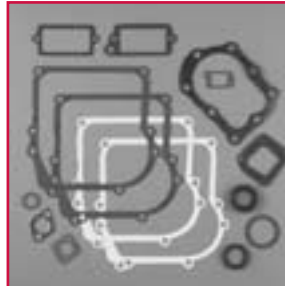

Gasket Set
3-3.75 HP Vertical

 298989

Gasket Set
10 & 11 HP Horizontal

497511 

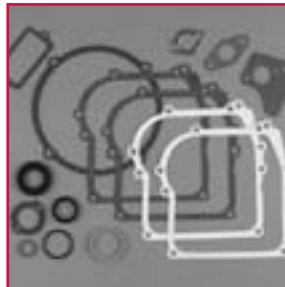
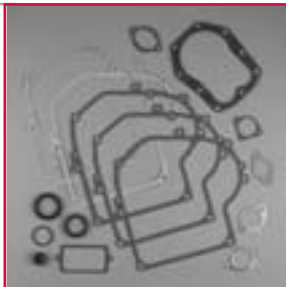

Gasket Set
3.5 HP Industrial Plus™

 496865

Gasket Set
13, 14 & 15 HP (28 CID)
OHV Vertical

495993 

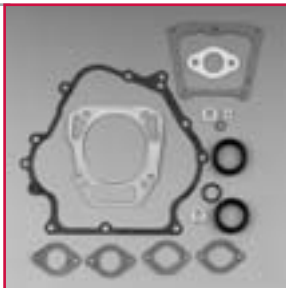

Gasket Set
5 HP Industrial Plus™

 495661

Gasket Set
4 & 4.5 HP Vanguard™
(8 & 11 CID)

715032 

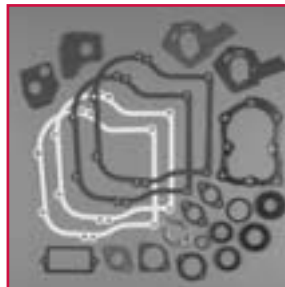

Gasket Set
5 HP Horizontal

 495603

Gasket Set
9 HP (18 CID) HP

715124 



Gasket Set
Quantum® (12 CID)

 496117



Gasket Set
11 & 13 HP Vanguard™
Horizontal

715383 

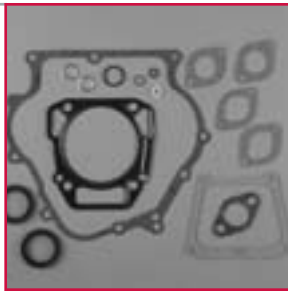

Gasket Set
12.5-16 HP V-Twin Vanguard™
Horizontal & Vertical

808390 



Gasket Set
18 HP V-Twin Vanguard™
Horizontal & Vertical

808389 



Gasket Set
6 HP Intek™

695155 



INTERNAL PARTS

6-10 HEAD GASKETS

INTERNAL PARTS

Head Gasket
Fource™

696865 



Head Gasket
Quantum® (12 CID)
12A, 12B, 12C etc.

 692249

Head Gasket
2-3.5 HP Horizontal

272167 

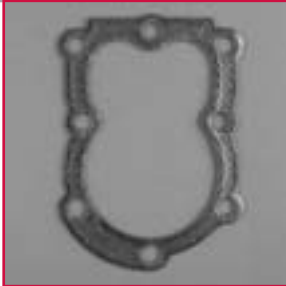

Head Gasket
7 & 8 HP Horizontal &
Vertical

 272163S

 4121 Qty. 5

Head Gasket
3-3.75 HP (9 CID) Vertical

272536S 

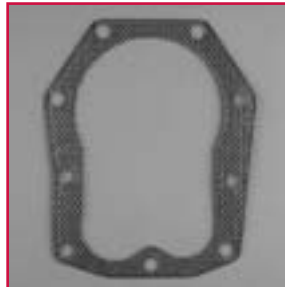

Head Gasket
10, 10.5, 11.5, 12 HP, 13 & 13.5
HP Horizontal/Vertical

 271866S

4123 Qty. 5 

 4125 Qty. 5

Head Gasket
9D900 Series

692288 



Head Gasket
All L-Head Twins
(Cylinder #1)

 271867S

Head Gasket
5 HP Horizontal & Vertical

272157S 



Head Gasket
All L-Head Twins
(Cylinder #2)

 271868S

4120 Qty. 5 

Head Gasket
Quantum® (12 CID)

272200S 

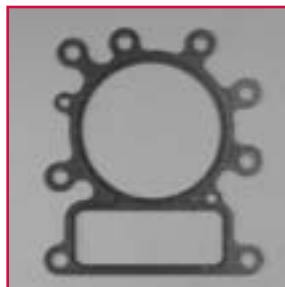
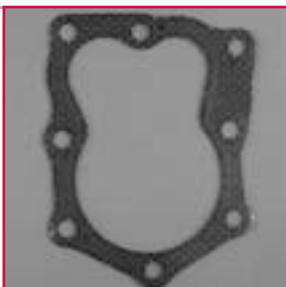

Head Gasket
13, 14 & 15 HP (25 CID)
15.5 Intek™ OHV Vertical

 273280S

4122 Qty. 5 



Head Gasket
4 HP (8 CID) Vanguard™

710137 



Head Gasket
18 & 20 HP V-Twin Vanguard™
Horizontal & Vertical (2 used)

 805653S



Head Gasket
5.5 HP (11 CID) Vanguard™

710021 

Head Gasket
18 & 20 HP Vanguard™ V-Twins
After Date Code 96033100

 690888

Head Gasket
9 HP (18 CID) Vanguard™

710205 



Head Gasket
6 HP Intek™

 695166

Head Gasket
11 & 13 HP Vanguard™
Horizontal

710539 



Head Gasket
12.5-16 HP V-Twin Vanguard™
Horizontal & Vertical (2 used)

807986 



Head Gasket
12.5 & 16 HP Vertical Vanguard™
V-Twins After Date Code 96033100

806085S 

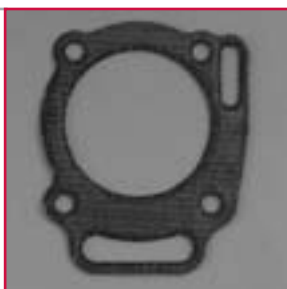

6-12 OIL GARD® GASKET & VALVE COVER GASKET

INTERNAL PARTS

Oil Gard® Gasket
Selected Models Equipped
w/Oil Gard®
273326S 



Valve Cover Gasket
9 HP (18 CID) Vanguard™
 **710206**



Valve Cover Gasket
Used as a Breather Gasket for
Europa™ OHV (9 CID) and Valve
Cover Gasket for Quantum® (12
CID) & Intek™ (11&12 CID)
272481S 



Valve Cover Gasket
11 & 13 HP Vanguard™
Horizontal
 **710377**



Valve Cover Gasket
Europa™ (9 CID)
272323 



Valve Cover Gasket
12.5 & 14 HP (26 CID) Vertical
Vanguard™
 **272010**

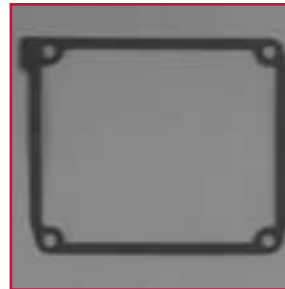

Valve Cover Gasket
4 & 5.5 HP Vanguard™
(8 & 11 CID)
710024 

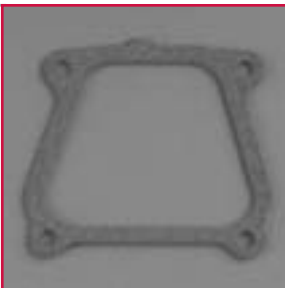

Valve Cover Gasket
12.5-20 HP Horizontal &
Vertical V-Twin Vanguard™
 **806039S**

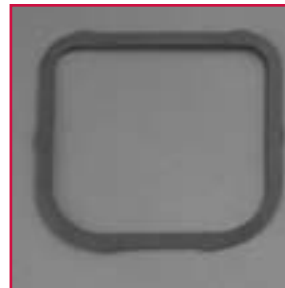

Valve Cover Gasket
5 HP (10 CID) Vertical
Vanguard™
272131 

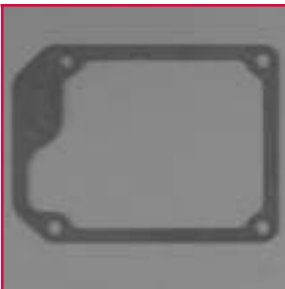

Valve Cover Gasket
13, 14 & 15 HP (28 CID) OHV
Vertical
 **272475S**

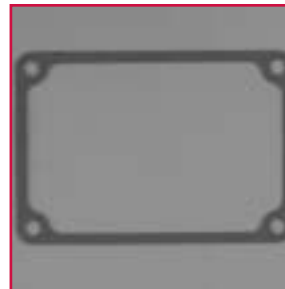

Valve Cover Gasket
9 HP (16 CID) Vanguard™
272063 

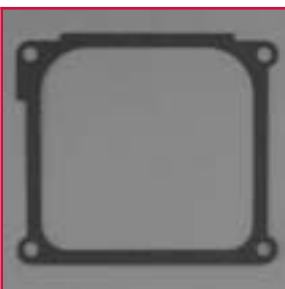

Valve Cover Gasket
3/LC
 **820150**

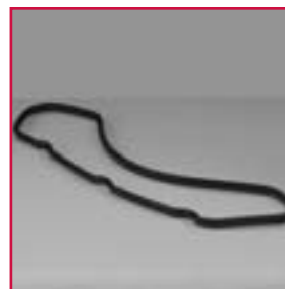

VALVE COVER GASKETS & VALVE OVERHAUL GASKET SETS 6-13

Valve Cover Gasket
6 HP Intek™

691890 



Valve Overhaul Gasket Set
5 HP Industrial Plus™

 498531



Valve Overhaul Gasket Set
3 & 3.5 HP Horizontal 90200 &
91200 Series

498524 



Valve Overhaul Gasket Set
Quantum® (12 CID)

 498528



Valve Overhaul Gasket Set
3.75-4 HP Vertical

498526 



Valve Overhaul Gasket Set
6 HP Vertical (13 CID)

 498532



Valve Overhaul Gasket Set
3.5 HP Horizontal
92200 & 93200 Series

498694 



Valve Overhaul Gasket Set
7 & 8 HP Horizontal

 498533



Valve Overhaul Gasket Set
Europa™ (9 CID)

496056 

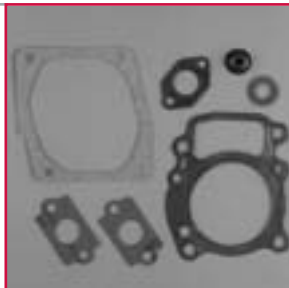

Valve Overhaul Gasket Set
8 HP Industrial Plus™
9 & 10 HP Horizontal

 498534



Valve Overhaul Gasket Set
5 HP Horizontal

498529 



Valve Overhaul Gasket Set
8 & 8.5 HP Vertical

 498536

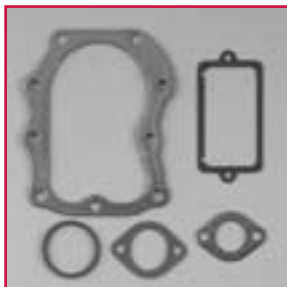

INTERNAL PARTS

6-14 VALVE OVERHAUL GASKET SETS

INTERNAL PARTS

Valve Overhaul Gasket Set
10 & 11 HP Horizontal
Industrial Plus™

498538 



Valve Overhaul Gasket Set
9 HP (16 CID) Vanguard™

 495771



Valve Overhaul Gasket Set
10 & 11 HP Horizontal I/C®

498537 



Valve Overhaul Gasket Set
9 HP (18 CID) Vanguard™

 715695



Valve Overhaul Gasket Set
Model 28 OHV Vertical

495992 



Valve Overhaul Gasket Set
11 & 13 HP Vanguard™ Horizontal

 715386



Valve Overhaul Gasket Set
10-14 HP L-Head Vertical
(28 CID)

498539 

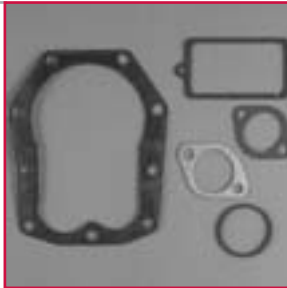

Valve Overhaul Gasket Set
12.5-16 HP V-Twins, Horizontal &
Vertical, After Code 90091000

 808392



Valve Overhaul Gasket Set
16 HP Horizontal Cast Iron I/C®

498540 



Valve Overhaul Gasket Set
18 HP (35 CID) V-Twin Vanguard™
Horizontal & Vertical

 808391



Valve Overhaul Gasket Set
5.5 HP (11 CID) Vanguard™

715704 



Valve Overhaul Gasket Set
6 HP Intek™

 695289

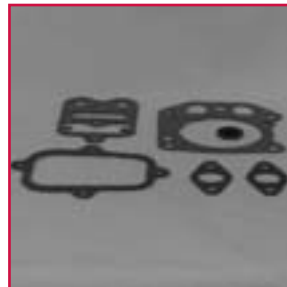



Engine Type L-Head	Part Number Single	Part Number Bulk - Qty.
2-5 HP Including Quantum®, Europa™ and Intek™	299819S	4116 - Qty. 5
3-4 HP Vertical (PTO End)	391483S	4118 - Qty. 5
5 HP Industrial Plus™ (PTO End)	495307S	
5 HP Vertical (PTO)	391485	
5 HP Horizontal (PTO)	393812	
5.5 HP Intek™ (PTO)	692550	
Quantum® (PTO End)	399781S	
5-8.5 HP	294606S	
7-15 HP	391086S	4117 - Qty. 5
10-15 HP (28 CID) Vertical (PTO End)	291675S	4115 - Qty. 5
Force™	696879	

Engine Type Vanguard™	Part Number Single
4 HP (8 CID) Vanguard™ (Mag End)	710103
4 HP (8 CID) Vanguard™ (PTO End)	710140
5.5, 6.0 & 9 HP Vanguard™ (Mag End)	710000
5.5 HP (11 CID) Vanguard™ (PTO End)	710031
Model 138400	710215
9 HP (18 CID) Vanguard™ (PTO End)	710215
All V-Twin Vanguard™	
Horizontal & Vertical (Mag End)	805101S
All V-Twin Vanguard™	
Horizontal & Vertical (PTO End)	805049S
Dipstick Tube Seal	
9 HP (18 CID) Vanguard™	710394

Engine Type 3/LC	Part Number Single
PTO side	820056
Mag. side	820055

LUBRICATION

7-2 OIL FILTERS & MISCELLANEOUS

LUBRICATION

Oil Filter
For Pressure Lubrication
& 3/LC Gas (Ht. 3-3/8")

491056 

4153 



Oil Plug/Dipstick
100700 Series Vertical

 280663



Oil Fill Plug
Selected Engines with Angled
Oil Fill Neck

 281658S

 5061B



Oil Fill Cap
3/LC

 825024



Oil Filter Premium Plus
Extended Life Version of
492932S/5049B/4154

696854 

5076D 

4206 



Oil Filter
3/LC
Gas & Diesel

820314 



Dipstick Tube Seal
7 & 11 HP Horizontal,
12 & 13 HP (28 CID) Vertical, and
Vanguard™ V-Twin Horizontal

 281370S



Oil Filter Intek™ Pro
Selected Models
Pressure Lubrication

692513 



Oil Gard® Kit
5 HP Industrial Plus™

 496605



Oil Gard® Kit
9 HP Vanguard™

492697 



Oil Gard® Kit
5-11 HP Horizontal Engines
Equipped to Receive

 496605



Electric Starter Drive Kit

Old Style Electric Starter
w/Roll Pin

495878 



Handle Pin

Older Style Grip That Requires Pin

 230228S

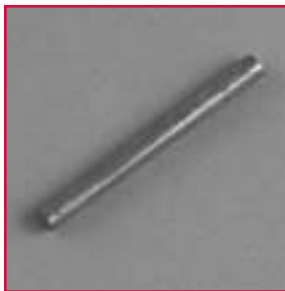

Electric Starter Drive Kit

New Style Electric Starter
w/ "C" Ring Retainer

497606 



Rope Guide

Extended Rope Start Models

 396526



Electric Starter Gear Kit

Old Style Electric Starter
w/Roll Pin

495877 



Starter Pawl (Steel)

Selected Engines w/Eaton
Starter

 492833

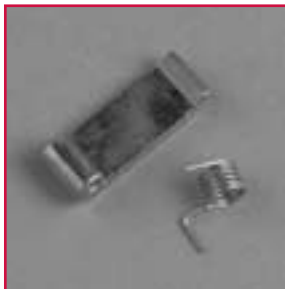

Starter Pinion Gear

6 HP Intek™

692353 

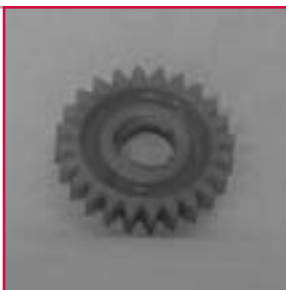

Starter Pawl (Nylon)

Selected Engines w/Susa
Starters

 281505S

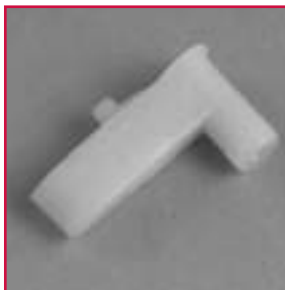

Starter Pinion Gear

Use with Plastic Flywheel
Ring Gears

693058 



4152 

Starter Pinion Gear

Use with aluminum Flywheel
Ring Gears

693059 



4155 

8-2 RECOIL PULLEYS

STARTING SYSTEMS

Recoil Pulley
2-4 HP

280439S 



Recoil Pulley
2 Cycle (9 CID)

 800011



Recoil Pulley
3.5-3.75 HP Vertical
(Sprint™ & Classic™)

281336S 



Recoil Pulley w/Spring
6 HP OHV Vertical, 5, 5.25 & 6 HP
Quantum®, 5 HP Horizontal, 6 HP
Intek™ with Susa Starters

 498144



Recoil Pulley
3-4 HP Vertical Pull Starter

299948 



Recoil Pulley w/Spring
Quantum® (12 CID), 5 HP (10
CID) Vertical Vanguard™, 4 & 5.5
HP Vanguard™

 493824

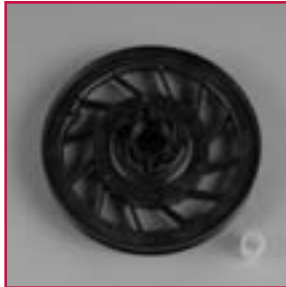

Recoil Pulley
Quantum® (10 CID)

490877 



Recoil Pulley
9 HP (16 CID) Horizontal
Vanguard™

 281235



Recoil Pulley
5-16 HP

295871 



Recoil Pulley
9 HP (18 CID) Horizontal
Vanguard™ & 12.5-14 HP
(26 CID) Vertical Vanguard™

 494956



Recoil Pulley
9-16 HP Horizontal
(Cast Iron Models)

392630 



Recoil Pulley
V-Twin Vanguard™

 280918



Recoil Spring
2 Cycle (9 CID)

802508 



Recoil Spring
4, 5.5, 6 & 7 Vanguard™
Horizontal

 710270



Recoil Spring
Most Rewind Starter
Engines with Starter Clutch

490179 

5010B 



Starter Clutch
16 HP Horizontal Cast Iron
Engines

 393127S



Recoil Spring
3-4 HP Vertical Pull Starter

390066 



Starter Clutch
Most Rewind Starter
Engines

 399671



Recoil Spring
Europa™ (9 CID) 4 & 5.5 HP
Vanguards™, 5 HP Industrial
Plus™ Quantum® (10 CID)

491889 



Recoil Spring w/Pulley
Quantum® (12 CID) & 5 HP
(10 CID) Vertical Vanguard™

493824 



Recoil Spring
9-18 HP Vanguard™
(Old & New)

492194 



8-4 STARTER GRIPS

STARTING SYSTEMS

Starter Grip
2-5.5 HP, Quantum® & Europa™
(9 CID) & All Vertical Pull Starters

393152 

5042, 5054 

4119 Qty. 5 



Starter Grip
3.5-18 HP

490652 

4130 Qty. 5 



Starter Grip
Selected Models

281434S 



Starter Grip
Single Cylinder Vanguard™
Horizontal, Selected Models

715257 



Starter Grip
Mitten Grip
Sno-Gard® Engines

695740 



Starter Grip
6 HP Intek™

691915 



Individual Starter Ropes

Use With	Size	Part Number	Comments
2-4 HP	#4	66734	48" Long
3.5-5 HP	#4	490876	82" Long
3.5-4 HP, 5 HP (10 CID) Vertical Vanguard™	#4	280406S	5042B is display pack
2 cycle (9 CID), Europa™, Quantum®, 4 & 5.5 HP Horizontal Vanguard™ (99")	#4	280399S	5054B is display pack
5-18 HP	#5	692188	63" Long
12.5-18 HP	#5-1/2	695002	99" Long - Vanguard™ Single & Twin
-----	#5-1/2	69932S	Starter rope with handle - Use with most rope starter engines
Fource™		696974	

STARTING SYSTEMS

Bulk Starter Rope

Description	Size	Part Number
500 ft. Spool	#3-1/2	693190
250 ft. Spool	#4	390619
500 ft. Spool	#4	693191
230 ft. Spool	#4-1/2	390620
500 ft. Spool	#4-1/2	693192
160 ft. Spool	#5-1/2	390621
500 ft. Spool	#5-1/2	693193

Rewind Starter Bumpers

Rounded (Use only with steel pulley)	68618
Flat (Use only with steel pulley)	68848S



**Switch For Water
Temperature Light**
3/LC

820208 



Thermostat Gasket
3/LC

 820093



**Switch For Water
Temperature Fan**
3/LC

820277 



Water Pump Gasket
3/LC

 820100



Thermostat
3/LC

825064 



Water Pump Inlet Gasket
3/LC

 820098

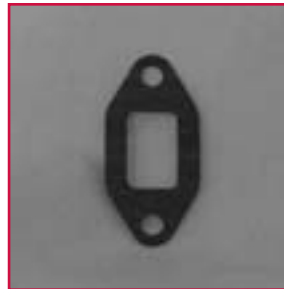

Water Pump
3/LC Gas
582400

825275 

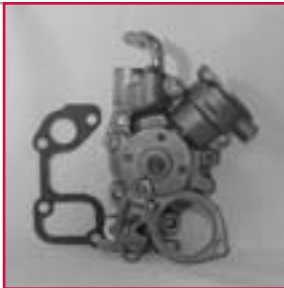

Water Pump
3/LC
432400 & 522400

 825265



Radiator Cap
3/LC

820258 



Water Pump
3/LC
522400 Type 107

 825432



Radiator
3/LC

825068 



Fuel Pump
3/LC Gas

 825232



WATER COOLED

9-2 3/LC PARTS

WATER COOLED

Injectors
3/LC Diesel

825178 



Ignition Module
3/LC Gas

 825273



Injector Seat
3/LC Diesel

820411 



Exhaust Muffler
3/LC

 825301



Glow Plug
3/LC Diesel

825176 



Gasket Intake Manifold to Head
3/LC Gas

 820087



Glow Plug Timer
3/LC Diesel

820373 



Gasket Intake Manifold to Head
3/LC Diesel

 820407

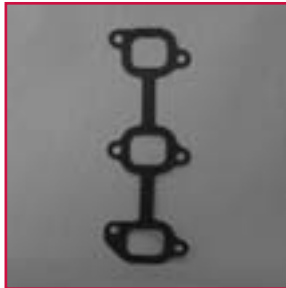

Fuel Filter
3/LC Diesel

820311 



Valve Cover Gasket
3/LC

 820150



Ignition Trigger
3/LC Gas

825009 



Valve Overhaul Gasket Set
3/LC Gas
430400, 437400, 580400, 587400

 825379

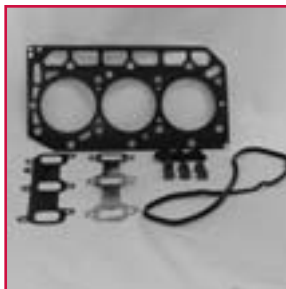

Gasket Set
3/LC Gas

825378 

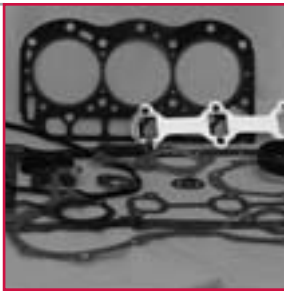

Head Gasket
3/LC Diesel
432400

 820658

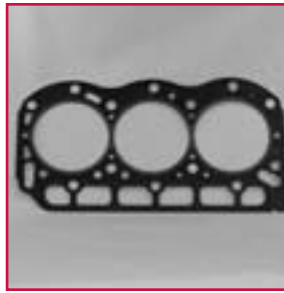

Gasket Set
3/LC
432400

825212 

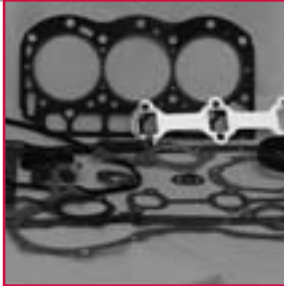

Head Gasket
3/LC Diesel
522400

 820621

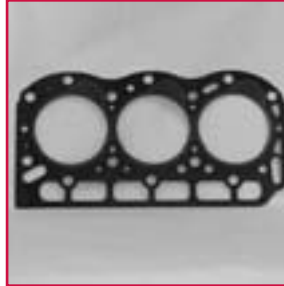

Gasket Set
3/LC
522400

825315 

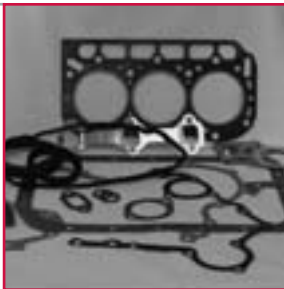

Head Gasket
3/LC Diesel
532400

 820660

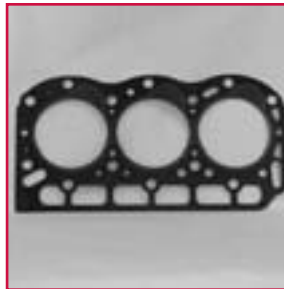

Gasket Set
3/LC
582400

825380 

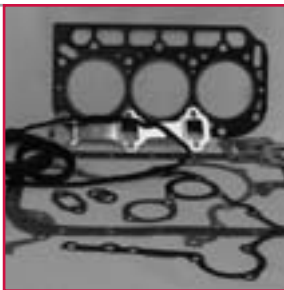

Head Gasket
3/LC Gas
430400, 437400

 820650



Valve Overhaul Gasket Set
3/LC Diesel
432400

825213 

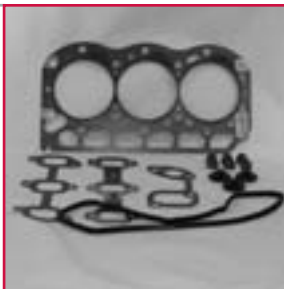

Valve Overhaul Gasket Set
3/LC Diesel 582400

 825381



Valve Overhaul Gasket Set
3/LC Diesel
522400

825316 

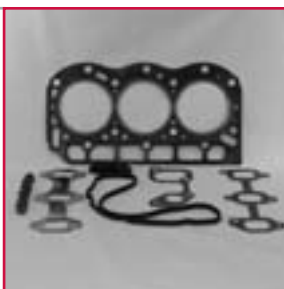

Oil Pressure Switch
3/LC

 825000



WATER COOLED

9-4 3/LC ELECTRICAL CONNECTORS

WATER COOLED

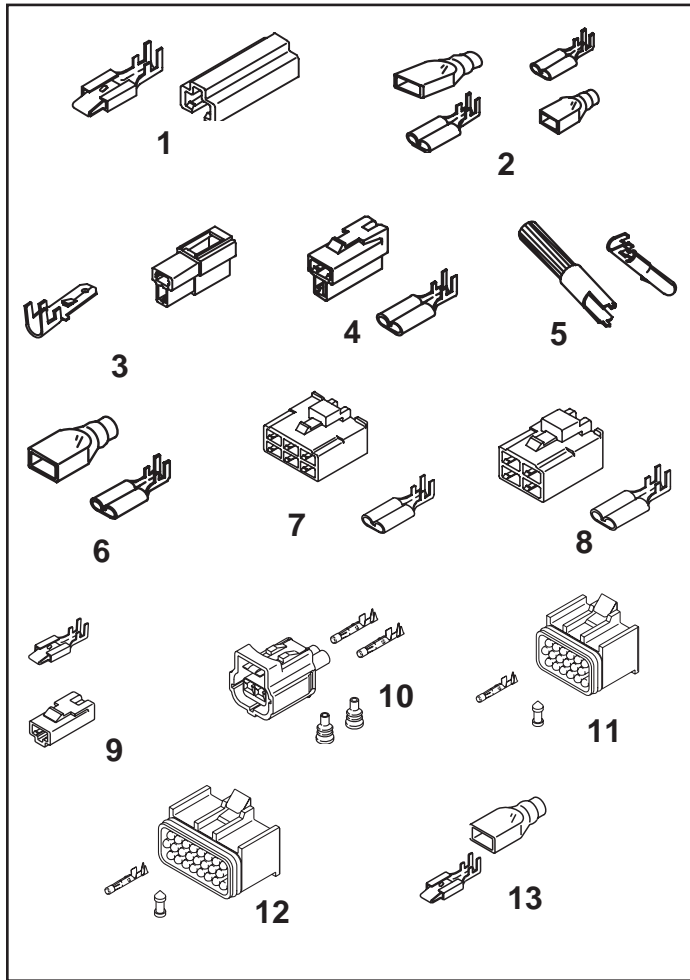

ELECTRICAL CONNECTORS

<u>REF. NO.</u>	<u>PART NO.</u>	<u>TERMINAL CONNECTORS USED ON</u>
1	825154	Oil pressure switch, water pressure switch
2	825155	Coil-ignition wire kit
3	825156	Female fuel filter, fuel pump, and ignition trigger
4	825157	Male fuel pump, alternator, ignition trigger, fuel filter, and fan motor
5	825158	Solenoid
6	825160	Water temperature switch and water pump switch
7	825162	Pre heat timer (Ignition Module, Male)
8	825163	Ignition Module, Male
9	825266	Fuel injection pump, starter terminal
10	825288	Water temp switch
11	825289	Electronic gov. control module 12 Pins
12	825290	Electronic gov. control module 10 Pins
13	825322	0.8 KW starter

19300 BASIC TOOL KIT

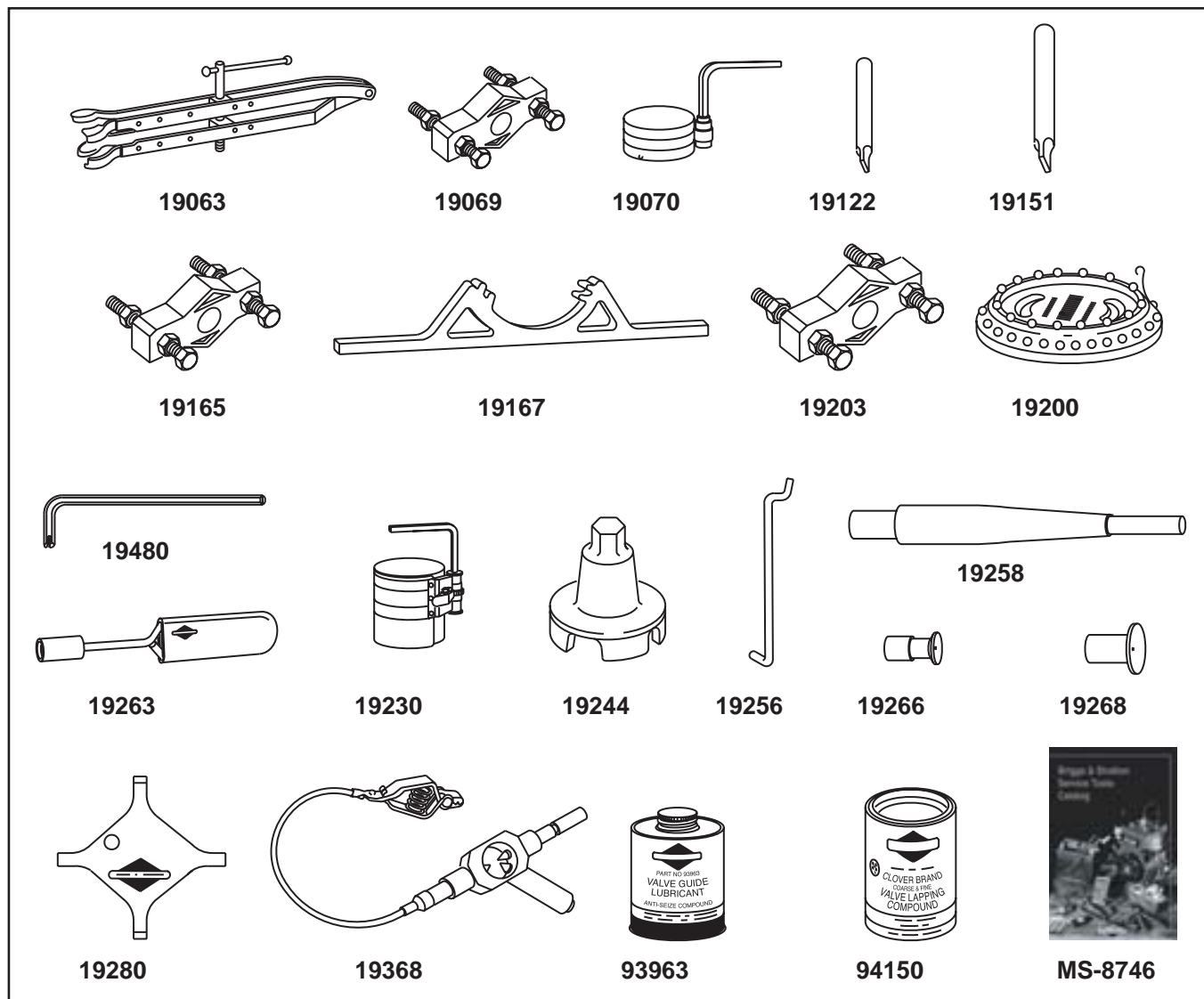

KIT INCLUDES:

- | | | | |
|-------|---|---------|---|
| 19063 | Valve Spring Compressor | 19244 | Starter Clutch Wrench |
| 19069 | Flywheel Puller | 19256 | Brake Adjustment Gauge |
| 19070 | Piston Ring Compressor (5 HP and below) | 19258 | Valve Lapper* (includes 19266 and 19268) |
| 19122 | Plug Gauge – 1/4" Valve Guide | 19263 | Screwdriver – Carburetor Adjustment |
| 19151 | Plug Gauge – 5/16" Valve Guide | 19280 | Screwdriver – Carburetor Jet – (4 Bladed) |
| 19165 | Flywheel Puller | 19368 | Tester – Ignition |
| 19167 | Flywheel Holder | 93963 | Lubricant – Valve |
| 19203 | Flywheel Puller | 94150 | Valve Lapping Compound |
| 19200 | Tachometer | MS-8746 | Tool Catalog |
| 19480 | Tang Bender | | |
| 19230 | Piston Ring Compressor (above 5 HP) | | |

NOTE: Each tool part number can also be ordered separately.

*To order replacement suction cups, specify:
 19266 – 3/4" (19.1 mm)
 19267 – 1" (25.4 mm)
 19268 – 1-1/4" (31.8 mm)

TOOLS

19237 NEWAY VALVE SEAT CUTTER KIT

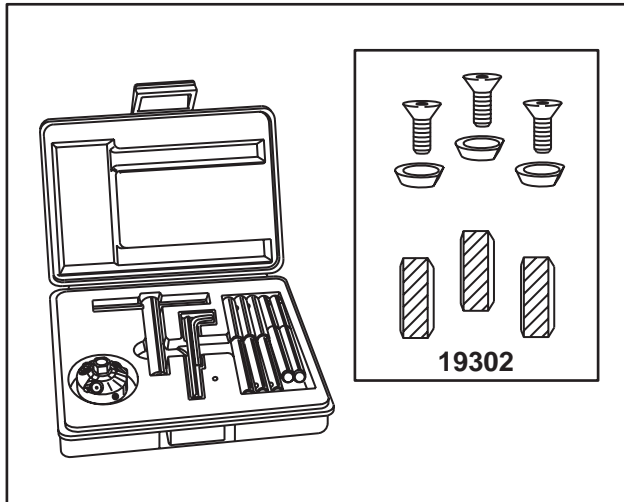

For reconditioning 30° and 45° angle valve seats.

NOTE: For replacement tungsten carbide blade set, specify part number 19302. Set includes:

- 3 blades – use on either side of cutter head
- 3 set screws
- 3 wedges

Replace blades in sets only.

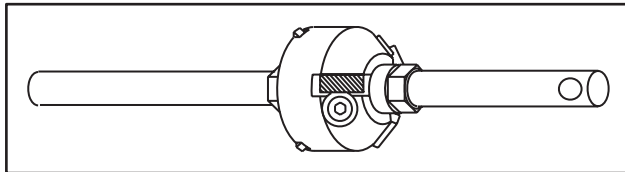

19343 VALVE SEAT CUTTER KIT

For use on Quantum® and Vanguard™ OHV engines. Includes 6 mm pilot for Vanguard™ engines.

19340 Ring Expander

For removing and installing piston rings. Minimizes ring distortion and breakage. All engine models.

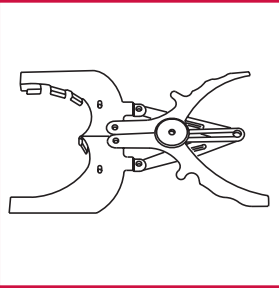

19389 Digital Tachometer - Hourmeter

Meter displays RPM while engine is running. When engine is stopped, meter displays elapsed time.

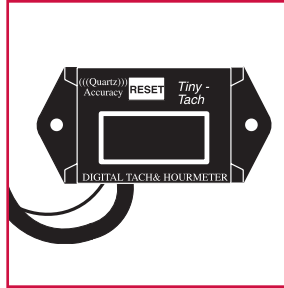

5056 B Pump, Oil Evacuator

Handy tool for draining oil from engines with restricted access. Use with an electric drill. Inlet and outlet hose included.

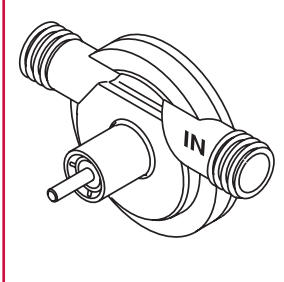

19433 Flywheel Strap Wrench

For holding flywheel while removing and torquing flywheel nut. All engine models. **NOTE:** Replacement strap is available separately. Order Part #19448

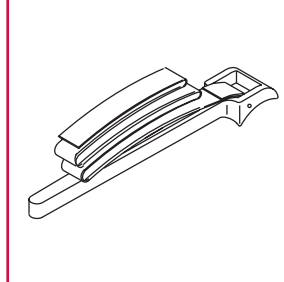

Screwdrivers - Carburetor Jet

For removing most carburetor jets.

- 19061 Screwdriver
- 19062 Screwdriver

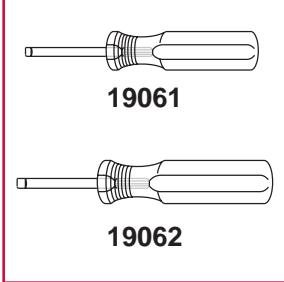

19446 Neway Valve Seat Cutter Kit

For reconditioning 30° and 45° angle valve seats on Vanguard™ 3 cylinder liquid cooled engines. Includes 15° cutter for top cutting 30° angle seats. Includes 6.0 and 6.02 mm pilots.



19400 Spark Tester

Special Air Gap of .400" (10 mm) for use on Vanguard™ 3 Cylinder Liquid Cooled Engine.

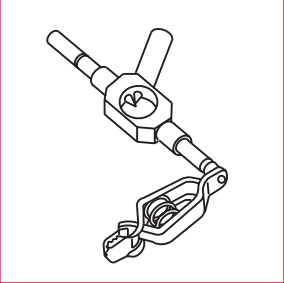

19457 Digital Tachometer - Hourmeter

For use on Vanguard™ 3 cylinder liquid cooled diesel engines with 6mm diameter fuel lines.

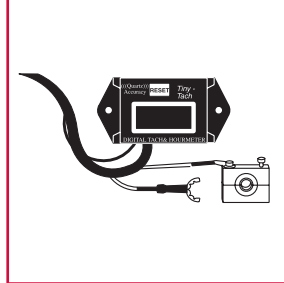

19475 Leakdown Tester

Used to test the sealing capabilities of the compression components of all engines. Comes with crankshaft clamp.

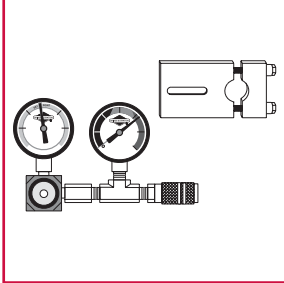

19468 DC AMP Shunt

An improved version of a valuable diagnostic tool. Color coded receptacles hold digital multimeter leads securely while testing. This tool works with any digital multimeter with a milivolt scale.

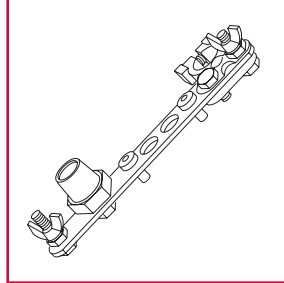

19443 Compression Test Adapter

For testing compression on Vanguard™ 3 cylinder liquid cooled diesel engines.

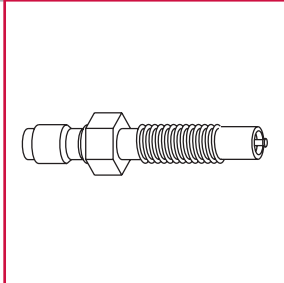

19461 Primer Bulb Removal Tool

For quick and easy removal of primer bulb and retainer on engines equipped with primer bulb system.

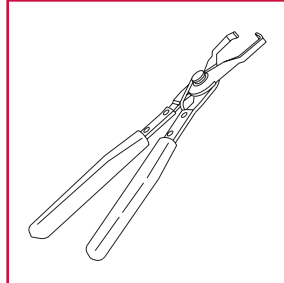

10-4 INDIVIDUAL TOOLS

19480 Tang Bender

For all engines. Used for setting top no load and governed idle speeds.



Individual Torquex Drivers

Individual Torquex replacement bits

19510 – T-10	19513 – T-27
19511 – T-15	19514 – T-30
19512 – T-20	19515 – T-40
19482 – T-25	19516 – T-45

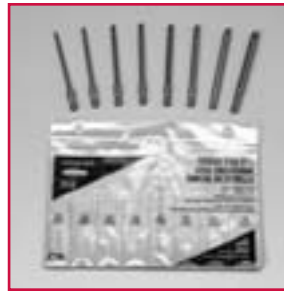

19495 Digital Crankcase Vacuum Tester

Extremely accurate and simple tool for measuring crankcase vacuum. Modify an old dipstick or oil fill plug by installing a barbed connector and attach the hose from the gauge.

Check crankcase vacuum with engine running at top no load speed.



19524 T30 Torx Bit

For removing and installing tamper proof screw used on Touch-N-Mow™ starters.



19522 C-Ring Removal Tool

For removing C-ring on starter motor when replacing starter motor drive.

All models.
Replaces 19436

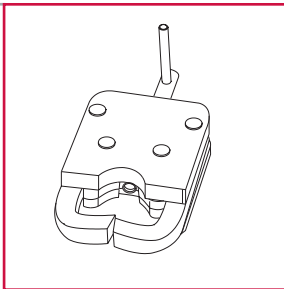

Quantum® 3.5-6.5 HP Maintenance Kit

Contains 4-cycle 30W oil 100005; air filter cartridge 491588S; spark plug 802592S; fuel stabilizer 100031



5106A

Intek™ Snow 6.5-13 HP Maintenance Kit

Contains snow 5W-30 oil 100030C; spark plug 5062B; fuel stabilizer 100031. Kit does not include air filter.



5112A

Classic™-Sprint™-Quattro™ 3.5-4 HP Maintenance Kit

Contains 4-cycle 30W oil 100005; foam air filter 272235S; spark plug 802592S; fuel stabilizer 100031



5107A

Snow 4-5 HP Maintenance Kit

Contains snow 5W-30 oil 100030C; spark plug 802592S; and fuel stabilizer 100031. Kit does not include air filter.



5113A

Intek™ Edge/Intek™ Pro 5.5-6.75 HP Maintenance Kit

Contains 4-cycle 30W oil 100005; air filter cartridge 693064; pre-cleaner 273356S; spark plug 491055S; fuel stabilizer 100031



5108A

Vanguard™ 5.5-9 HP Maintenance Kit

Contains 4-cycle 30W oil 100028; air filter cartridge 491435; spark plug 491055S; fuel stabilizer 100031



5114A

Single Cylinder Tractor 10.5-13.5 HP Maintenance Kit

Contains 4-cycle 30W oil 100028; air filter cartridge 496894S; pre-cleaner 272403S; spark plug 802592S; fuel stabilizer 100002



5109A

Generator 7-11 HP Maintenance Kit

Contains 4-cycle 30W oil 100028; air filter cartridge 496077S; pre-cleaner 492889; spark plug 802592S; fuel stabilizer 100002; fuel filter 394358S; hose clamp 95162S



5115A

Twin Cylinder Tractor 14-23 HP Maintenance Kit

Contains 4-cycle 30W oil 100028; air filter cartridge 394019S; pre-cleaner 272490S; (2) spark plugs 802592S; fuel stabilizer 100002



5110A

Vanguard™ 9-13 HP Maintenance Kit

Contains 4-cycle 30W oil 100028; air filter cartridge 710266; pre-cleaner 710268; spark plug 491055S; fuel stabilizer 100002



5116A

Intek® V-Twin ELS 18-26 HP Maintenance Kit

Contains 4-cycle 30W oil 100005 and 100028; oil filter 492932S; air filter cartridge 695667; (2) spark plugs 694385; fuel stabilizer 100002; fuel filter 695327; (2) clamps 93807



5111A

Intek® 8-11 HP Maintenance Kit

Contains 4-cycle 30W oil 100028; spark plug 491055S; air filter cartridge 491588S; pre-cleaner 493537S; fuel stabilizer 100002



5117A



11-2 MAINTENANCE CARE PRODUCTS & COUNTER MERCHANDISERS

ACCESSORIES

Intek® I/C® Intek Pro® 8-10.5 HP Maintenance Kit

Contains 4-cycle 30W oil 100028; air filter cartridge 695302; pre-cleaner 695303; spark plug 491055S; fuel stabilizer 100002



5118A

Intek™ 5.5-6.5 HP Maintenance Kit

Contains 4-cycle 30W oil 100005; air filter cartridge 491588S; pre-cleaner 493537S; spark plug 491055S; fuel stabilizer 100031



5121A

Vanguard™ V-Twin 12-21 HP Maintenance Kit

Contains 4-cycle 30W oil 100005; 4-cycle oil 30W 100028; oil filter 492932S; air filter cartridge 394018S; pre-cleaner 272490S; (2) spark plugs 491055S; fuel stabilizer 100002; fuel filter 691035; hose clamp 95162S



5119A

Vanguard™ Intek™ 14-17.5 HP Maintenance Kit

Contains 4-cycle 30W oil 100028; air filter cartridge 496894S; pre-cleaner 272403S; spark plug 491055S; fuel stabilizer 100002



5122A

Vanguard™ V-Twin 21-23 HP Maintenance Kit

Contains 4-cycle 30W oil 100005; 4-cycle 30W oil 100028; oil filter 492932S; air filter cartridge 692520; spark plug 491055S; fuel filter 691035; hose clamp 692519; fuel stabilizer 100002



5120A

Power Built™ I/C® 8-11.5 HP Maintenance Kit

Contains 4-cycle 30W oil 100028; air filter cartridge 691667; pre-cleaner 272477S; spark plug 802592S; fuel stabilizer 100002



5123A

Power Built™ 8-9 HP Maintenance Kit

Contains (2) 4-cycle 30w oil 100005; foam air filter 272922; spark plug 802592; fuel stabilizer 100002



5124A

COUNTER MERCHANDISERS

Small Engine Care & Repair Guide Counter Display – 6/box

274041



Gasoline Additive

Counter Merchandiser – 36/box,
(Order #4127, Refill – 50/box)

100031



Tire Sealant

Counter Merchandiser – 8/box

100032A-32 oz.



Fuel Stabilizer Plus

Counter Merchandiser – 9/box

100002A



<p>Air Filter - Foam Air Filter Foam Element 27987S; 2-5 HP Horizontal</p> <p>5001D* </p>			<p>Air Filter Cartridge Contains Air Filter Cartridge 399877S; 3.5 Quantum® (10 CID)(Prior to 1989)</p> <p> 5028D*</p>
<p>Air Filter - Foam Air Filter Foam Element 270579S; 3 & 3.5 HP Lawn mower engines prior to 1992</p> <p>5009D* </p>			<p>Air Filter Cartridge Contains Air Filter Cartridge 491588S; 3-5 HP Horizontal, 3.0-6.0 HP (12 CID) Quantum®</p> <p> 5043D*</p>
<p>Air Filter - Foam Air Filter Foam Element 270528S; 7 & 8 HP Vertical</p> <p>5045D* </p>			<p>Air Filter Cartridge w/Pre-cleaner Contains Air Filter Cartridge 494511S & Pre-cleaner 492889; 3.5 & 5 HP Industrial Plus™, (11 CID) Vanguard™</p> <p> 5060D*</p>
<p>Air Filter - Foam Air Filter Foam Element 270843S; 10 & 11 HP Vertical</p> <p>5046D* </p>			<p>Air Filter Cartridge With Foam Pre-cleaner Used on 18 through 25 HP Intek™ V-Twin engines. For Extended Life Version, Use 5069D</p> <p> 5063D</p>
<p>Air Filter - Foam Air Filter Foam Element 272235S; 3.5-3.75 HP Classics™ & Sprint™ after 1992</p> <p>5047D* </p>			<p>Air Filter Premium Plus Cartridge Used on 18 through 25 HP Intek™ V-Twin engines. Contains Air Filter Cartridge 695091 – Four Times the Performance Extended Life Version of 5063D.</p> <p> 5069D </p>
<p>Air Filter Cartridge Contains Air Filter Cartridge 397795S; 3.5 & 4 HP Max Series & 2 cycle</p> <p>5027D* </p>			<p>Air Filter Premium Plus Cartridge w/Pre-Cleaner Used on 7 through 11 HP single cylinder Industrail Plus™ engine. Contains Air Filter Cartridge 691643 & Pre-cleaner 492889</p> <p> 5073D </p>

11-4 DISPLAY PACKS

ACCESSORIES

Air Filter Premium Plus Cartridge w/Pre-Cleaner

Contains Air Filter Cartridge 710266 & Pre-cleaner 710268; 9 through 13 HP Single Cylinder Vanguard™ engines

5074D



Air Filter Cartridge w/Pre-cleaner

Contains Air Filter Cartridge 394018S & Pre-cleaner 272490S; 12.5-20 HP Horizontal L-Head Twin & Vanguard™ OHV V-Twin

5050D*



Premium AVS™ Air Filter Cartridge

Contains 697015 Pre-cleaner; 697014 Air Filter Cartridge; 14 through 17.5 HP I/C®, Intek™, OHV and AVS™ engines

5077D



Air Filter Cartridge w/Pre-cleaner

Contains Air Filter Cartridge 394019S & Pre-cleaner 272490S; L-Head Twin Vertical

5052D*



Premium ELS™ Air Filter Cartridge

Contains 697153; 14 through 17.5 HP I/C®, Intek™, OHV, ELS and AVS™ engines
Extended Life Version of 5077D

5078D



Air Filter Cartridge

Contains Air Filter Cartridge 496894S & Pre-cleaner 272403S (12.5-17 HP); 12.5-15 HP Vertical

5053D*



Premium AVS™ Air Filter Cartridge

Contains 697292 Pre-cleaner; 697152 Air Filter Cartridge ; 8 through 13.5 HP Power Built™, OHV, I/C® and AVS™ engines

5079D



Air Filter Cartridge w/Pre-Cleaner

Contains Air Filter Cartridge 497725S & Pre-cleaner 273185; Europa™ (9 CID) OHV Vertical

5055D*



Air Filter Cartridge w/Pre-cleaner

Contains Air Filter Cartridge 396424S; 2-5 HP Horizontal

5026D*



Air Filter Cartridge w/Pre-cleaner

Contains Air Filter Cartridge 690610 & Pre-cleaner 273356S; Intek™ Model series 121600 OHV

5059D*



Air Filter Cartridge w/Pre-cleaner

Contains Air Filter Cartridge 399806S & Pre-cleaner 271962S; 10-12 HP Vertical

5048D*









































Air Filter Premium Plus Cartridge w/Pre-Cleaner

Contains Air Filter Cartridge 691667 & Pre-cleaner 272477; 8 through 12 HP single cylinder Power Built™ engines

5075D



<p>Oil Filter Oil Filter 492932S. For Extended Life Version, Use 5076D</p> <p>5049D*</p>  		<p>Fuel Tank Cap Fuel Tank Cap 497929S; 3.5 & 3.75 HP Classic™ & Sprint™ and 4 HP Quattro™</p> <p>5057D*</p>  	
<p>Oil Filter ELS™ Premium Plus Contains Oil Filter 696854 Extended Life Version of 5049D</p> <p>5076D</p>   		<p>Gas Cap Gas Cap 692046</p> <p>5068D</p>  	
<p>Fuel Filter Assembly Fuel Filter 298090S (150 Micron) & 2 Clamps 95053</p> <p>5018D*</p>  		<p>Touch-N-Mow Key® Touch-N-Mow® Key 695951</p> <p>5071D</p>  	
<p>Premium Fuel Filter Contains Filter 695666 & Clamp 691038 – Large Capacity – Two Times the Performance</p> <p>5070D</p>   		<p>Tractor Replacement Key Indak Replacement Keys 691959</p> <p>5072D</p>  	
<p>Premium Fuel Filter Used on ride-on/tractor engines with fuel pumps</p> <p>5065D</p>  		<p>Diaphragm Kit Diaphragm 272538, Spring 692206 & Spring Cap 690766; 2-5 HP Horizontal</p> <p>5021D*</p>  	
<p>Fuel Tank Cap Fuel Tank Cap 397974S; 3.5-6 HP Vertical Max, Quantum® & Europa™</p> <p>5044D*</p>  		<p>Flywheel Key Flywheel Key (3 of 222698S); Used on most engines</p> <p>5002D*</p>  	

11-6 DISPLAY PACKS

ACCESSORIES

Ignition Kit
Breaker Points 294628 &
Flywheel Key 222698S

5012D*



Ignition Kit - Magnetron®
Magnetron® Ignition Kit
394970. Converts breaker point
ignition to electronic ignition

5025D



Fuel Stabilizer
Fuel Stabilizer 100002
See page 11-9 for Fuel
Stabilizer features & benefits

5041D



Oil Fill Plug
Oil Fill Plug 281658S

5061D*



Fuel Stabilizer
3 tube blister pack - 1 Fl. oz. (.03
L). See page 11-9 for Fuel
Stabilizer features & benefits

5058D



Muffler
Muffler 89966 - Lifetime Warranty
Information supplied w/each package;
2 & 3 HP Horizontal

5006D*



Starter Rope w/Handle
Handle Grip 393152 & Rope
280406S

5042D



Muffler
Muffler 294599S - Lifetime Warranty
Information supplied w/each package;
7 & 8 HP

5011D*



Starter Repair Kit
Rewind Tool 19409, Rope
280399S & Handle 393152

5054D



Muffler
Muffler 394569S - Lifetime Warranty
Information supplied w/each package;
3-4 HP Vertical

5019D*



Ignition Kit - Tune-up
Breaker Points 294628, Spark
Plug 802592S, Plunger 65704S
& Flywheel Key 222698S

5020D*



Pump Kit
Pump Assembly 19410, Hose
19412, Tube-short 19427 &
Tube-long 19428

5056D



<p>Starter Spring Starter Spring 490179</p> <p>5010D</p>   			<p>Pinion Gear Starter Pinion Gear for aluminum and plastic ring gears only</p> <p>5080D</p>  
<p>Spark Plug (Platinum) L-Head. See Page 11-7 for Platinum Spark Plug features & benefits</p> <p>5062D**</p>   			<p>Maintenance Meter (Hour Meter) Display flashes every 25 hours run time. For 2 and 4 cycle engines</p> <p>5081D</p> 
<p>Spark Plug (Platinum) OHV. See Page 11-7 for Platinum Spark Plug features & benefits</p> <p>5066D**</p>   			<p>Maintenance Mate Includes preventative maintenance tools for most Briggs & Stratton engines</p> <p>5082D</p> 

****Platinum Spark Plug Features & Benefits**
Two Platinum Spark Plugs are now available-5062B for OHV engines. They provide long life, easy starting, increased ignitability, reduced fouling & idle stability. They are resistorized for RFI protection.

Display package options include:

5062D	Cut case tray of 8 plugs	5066D	Cut case tray of 8 plugs
4176	Shop pack of 8	4174	Shop pack of 8
4175	Shop pack of 24	4173	Shop pack of 24

ACCESSORIES

11-8 CLEANERS, GREASE, FUEL STABILIZER, MOTOR OIL & LUBRICANTS

ACCESSORIES

Battery Terminal Cleaner

11 oz. Can - Cleans battery terminals, cable connectors, casings, and retainer frames.

100067



Grease Gun Kit - Simple One Handed Operation

Kit includes steel grease gun, application tube, and one 3 oz. grease cartridge.

100057



Battery Terminal Protector

7.5 oz. Can - Prolongs battery life and assures faster, dependable starting.

100068



Grease Gun Refill Kit

Grease Refill Cartridges for Grease Gun Kit 100057

100058



Carburetor/Choke Cleaner

Quickly dissolves carburetor deposits, reduces downtime and improves starting.

100041 - 8 oz.
100042 - 16 oz.



Moly/Graphite Grease

14 oz. Cartridge - Provides maximum anti-wear protection. Ideal for industrial, automotive, and outdoor power equipment.

100059



Hand Cleaner

15.2 fl. oz. - Powerful cleansing agent with special conditioners and emollients to moisturize hands as it cleans.

100073



Lubricant 4-Use™

11 oz. - Frees rusted parts, displaces moisture, seals out rust, and stops corrosion. Protects tools, equipment, and all metals.

100043



Degreaser

15 oz. Heavy Duty - Powerful, industrially formulated cleaner. Quick removal of oil, hydraulic fluids, related contaminants.

100044



Fogging Oil

10 oz. Can - Special formulation for maximum internal rust protection for all 2 & 4-cycle engines

100062



Penetrating Oil

11 oz. Can - Superfast, powerful, concentrated penetrating solvent. Frees rusted nuts and bolts faster, displaces moisture and lubricants.

100070



Heavy Duty Silicone

7.5 oz Can - Lubricates, protects, waterproofs, and restores a wide range of parts and equipment.

100069



Motor Oil 4-Cycle
20 oz - High quality SAE 30 detergent oil - Specially formulated for higher operating temperatures of air cooled engines.

100005



Synthetic Oil - SAE 5W-30
32 oz. Recommended for use in all air-cooled small engines.

100074

Motor Oil 4-Cycle
48 oz. - High quality SAE 30 detergent oil - Specially formulated for higher operating temperatures of air cooled engines.

100028



Snow Blower Oil - SAE 5W-30
32 oz.

100030C

Motor Oil 2-Cycle
16 oz. - Ashless oil formulation with Fuel Stabilizer. Leaves no residue - prevents plug fouling & engine deposits.

100036



Fuel Stabilizer
Merchandiser Display - 36 1 oz. Pouches/box (One pouch treats 2-1/2 gal.). Keeps fuel fresh for up to 24 months. Promotes quick starts.

100031



5058D



4127

Motor Oil 2-Cycle
8 oz. - Ashless oil formulation with Fuel Stabilizer. Leaves no residue - prevents plug fouling & engine deposits.

272075



Fuel Stabilizer
4.2 oz. - Treats 10 gallons of gasoline

100002



5041D

Motor Oil 2-Cycle
3.2 oz. - Ashless oil formulation with Fuel Stabilizer. Leaves no residue - prevents plug fouling & engine deposits.

100037



Fuel Stabilizer
32 oz. for Shop Use - Treats 96 gallons of gasoline

100006

Fuel Stabilizer
Fuel Stabilizer keeps fuel fresh for up to 24 months. Promotes quick starts, reduces gum and varnish build-up, and improves engine performance.
Treats gasoline as follows:
4127 50 pouch refill for part number 100031
5041D Display pack - 4.2 oz. container - treats 10 gallons of gasoline
100002 4.2 oz. Container - treats 10 gallons of gasoline
100006 32 oz. Shop Pack - will treat 96 gallons of gasoline
100031 Counter Merchandiser - 36 1 oz. pouches - one box will treat 90 gallons of gasoline. Each pouch treats 2-1/2 gallons of gasoline. Order #4127, Refill-50/box

11-10 BRIGGS & STRATTON BRANDED – FUEL CANS

ACCESSORIES

1-1/2 Gallon Fuel Can
Made of durable plastic. Holds up to 1-1/2 gallons of fuel. 8 per case.

W121



5 Gallon Fuel Can-NO SPILL
Made of durable plastic. Holds up to 5 gallons of fuel. Spill-resistant nozzle shuts off automatically when tank is full. 4 per case.

**WCA-525
WCA-525P***

2-1/2 Gallon Fuel Can
Made of durable plastic. Holds up to 2-1/2 gallons of fuel. 8 per case.

W221



Smart-Fill® Fuel Can
2.5 gal. Capacity*
(w/Display Header)

**W10050
(100050A)**

5 Gallon Fuel Can
Made of durable plastic. Holds up to 5 gallons of fuel. 4 per case.

WM521



2-Compartment 1-1/2 Gallon Gas & 2-1/2 Quart Oil, Fuel Can
Two cans in one, keep oil on one side, gas on the other side. Made of durable plastic. 6 per case.

W150

6 Gallon Fuel Can
Made of durable plastic. Holds up to 6 gallons of fuel. 8 per case.

W611



5 Gallon Kerosene Can
Made of durable plastic. Holds up to 5 gallons of kerosene. 6 per case.

W1002

1-1/4 Gallon Fuel Can-NO SPILL
Made of durable plastic. Holds up to 1-1/4 gallons of fuel. Spill-resistant nozzle shuts off automatically when tank is full. 8 per case.

**WCA-125
WCA-125P***



Jerry Can w/Spout
5 gallon steel fuel tank. Leak proof closure, internally treated lining to prevent rust formation.

**WCA-530
WCA-530P***

2-1/2 Gallon Fuel Can-NO SPILL
Made of durable plastic. Holds up to 2-1/2 gallons of fuel. Spill-resistant nozzle shuts off automatically when tank is full. 6 per case.

**WCA-225
WCA-225P***



Replacement Nozzle Kit
Fits Briggs & Stratton gas and kerosene containers

T235C



For ordering information contact your Briggs & Stratton CSSD. *Meets California Air Resource Board (CARB) regulations

1/2" Bed Anchors
2600 lbs. rated capacity

9155511



14' Ratchet Tie Down
1500 lbs. break strength

1170511



Chrome Anchor Points
Rust free

9250911



15' Tow Strap
10,000 lbs. break strength

1014611



Recessed Mount Ring Anchor
5000 lbs. rated capacity

9153011



15' Ratchet Tie Down
5000 lbs. break strength

1171711



6' Motorcycle Tie Down
1200 lbs. break strength

1034211



16' Ratchet Tie Down
3000 lbs. break strength

1170611



6' Ratchet Tie Down
1500 lbs break strength

1170211



25' Ratchet Tie Down
10,000 lbs. rated capacity

1272511



12' Heavy Duty Cambuckle Tie Down
2500 lbs. break strength

1121211



Beneficial Features of Cargo Management Products

“Power Web Plus” (an exclusive, patented webbing that features 360° protection) technology that makes the straps 4 times more cut and tear resistant and over 20% more abrasion resistant.



11-12 Co-BRANDED – BATTERY ACCESSORIES

ACCESSORIES

<p>Battery Terminal Bolts</p> <p>B1500109</p>			<p>Battery Cable 19" – 6 gauge</p> <p>B2580010</p>
<p>Coated Top Post Battery Terminals</p> <p>B1501012</p>			<p>Battery Cable 43" – 6 gauge</p> <p>B2580011</p>
<p>Terminal Spreader</p> <p>B7000126</p>			<p>Battery Cable 49" – 6 gauge</p> <p>B2580012</p>
<p>Onboard 1-1/2 Amp. Regulated Trickle Charger</p> <p>B7001201</p>			<p>Mechanics Hydrometer</p> <p>B7062059</p>
<p>Terminal Lugs - 5/16</p> <p>B7000516</p>			<p>Battery Cleaning Brush</p> <p>B7000118</p>
<p>Booster Cables 12 ft – 10 gauge</p> <p>B7801226</p>			<p>Battery Cable Bolts with Wingnuts</p> <p>B1500142</p>



8' J-Bolt Battery Tie Down

B7011508



Flag Post Terminal Caps

Prevents Corrosion

B1500142



**Battery Terminal
Anti-Corrosion Washers**

B1600131



11-14 GENERAC PRESSURE WASHER & GENERATOR ACCESSORIES

ACCESSORIES

<p>Rotating Brush Use with all Pressure Washers up to 3000 PSI</p> <p>100509GS</p>			<p>High Pressure Hose Quick Connect Kit</p> <ul style="list-style-type: none"> • Designed for easy, convenient accessory hook-up to the trigger gun/ wand of your high-pressure washer <p>100518GS</p>
<p>Floor Brush Use with all Pressure Washers</p> <p>100510GS</p>			<p>Garden Hose Quick Connect Kit</p> <ul style="list-style-type: none"> • Designed for easy, convenient water hook-up • Fits all standard (5/8") garden hoses <p>100517GS</p>
<p>Commercial Pressure Washer Gun 4000 PSI</p> <ul style="list-style-type: none"> • Stainless Steel and Brass components for long life • Connects to high-pressure hose with 3/8" quick connect fittings • Fits all wands and accessories with M22 fittings <p>100505GS</p>			<p>Pump Saver 4 oz. w/Header Card</p> <ul style="list-style-type: none"> • Protects against freezing for safe, cold weather storage. • Provides longer pump life • Maintains seals and pistons • Prevents harmful buildup of hard water mineral deposits in pump <p>100515GS</p>
<p>Home Use Pressure Washer Gun 3200 PSI</p> <ul style="list-style-type: none"> • Stainless Steel and Brass components for long life • Fits all wands and accessories with M22 fittings <p>100506GS</p>			<p>1/4" x 25' Hose</p> <ul style="list-style-type: none"> • Fits all 1500 - 2400 PSI pressure washers with M22 fittings <p>100512GS</p>
<p>Turbo Wand Use with pressure washers with 2300-3000 PSI and 2.9-3.0 GPM ratings</p> <p>100511GS</p>			<p>3/8" x 25' Hose</p> <ul style="list-style-type: none"> • Fits all 1500 - 4000 PSI pressure washers with M22 fittings <p>100513GS</p>
<p>O-Ring Kit Replacement rings for pump accessories</p> <ul style="list-style-type: none"> • Replaces worn or damaged o-rings, washers and filters on Genrac guns, hoses and other accessories <p>100516GS</p>			<p>3/8" x 50' Hose</p> <ul style="list-style-type: none"> • Fits all 2500 - 4000 PSI pressure washers with quick connect fittings <p>100514GS</p>



For ordering information Contact your Briggs & Stratton CSSD.

GENERAC PRESSURE WASHER & GENERATOR ACCESSORIES 11-15

Vehicle/Boat Wash
One Gallon

100502GS



Degreaser Wash
One Gallon

100503GS



Deck Wash
One Gallon

100504GS



Multi-Purpose Wash
One Gallon

100501GS



120 Volt Locking Plug
30 amp Power

- Designed to eliminate unplugging of electrical power cords

100523GS



120-240 Volt Locking Plug
20 amp Power

- Designed to eliminate unplugging of electrical power cords

100522GS



ACCESSORIES





Profit Power Center (AM-9900)

- 4' wide x 7.5' tall, gray slate board with red accents
- Lighted canopy header
- Comes with 3 shelves, all hardware (27 hooks and accessories)
- FULLY ASSEMBLED- JUST PLUG IT IN!
- Consider Variations such as two units side by side shown on the photo.
- Contact your Authorized Central Sales & Service Distributor for more details. (To locate your CSSD, refer to map page in back of book)



Profit Power Island (AM-9909)

- 48" wide, 84-1/2" tall, 15" base
- Lighted header
- 2 adjustable lighted shelves (15-1/2" deep)
- Shelf template, hole caps and grommets
- Rubber shelf protectors
- Minimal assembly required



Profit Power Island (AM-9901)

- 32 Square feet of selling space (4 sq. ft. footprint occupies less space than a push mower)
- Briggs & Stratton logo header (not lighted)
- 3 shelves plus 2 base portions, with all the hardware (30 hooks and 6 shelf support)
- 2'x2'x4' gray slate board with red accent
- FULLY ASSEMBLED!
- Contact your Authorized Central Sales & Service Distributor for more details. (To locate your CSSD, refer to map page in back of book)



Profit Power Island (AM-9908)

- 53-5/8" wide, 84-1/2" tall, 15" base deck
- Lighted header
- 2 adjustable lighted shelves (15-1/2" deep)
- Shelf template, hole caps and grommets
- Rubber shelf protectors
- Minimal assembly required



For ordering information contact your Briggs & Stratton CSSD.

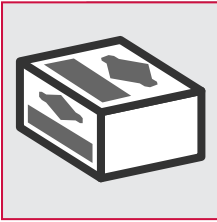

RED BOX P/N	DIY P/N	SHOP PACK P/N	SHOP PACK QTY.	DESCRIPTION	RED BOX P/N	DIY P/N	SHOP PACK P/N	SHOP PACK QTY.	DESCRIPTION
19069	5024			Flywheel Puller	271794S		4141	5	Pre-cleaner
19374	5067			Spark Plug Wrench	271866S		4125	5	Gasket Cylinder Head
19409	5054			Starter Rewind Tool	271962S	5048	4110	4	Pre-cleaner
27355S		4160	10	Gasket Intake	272157S		4120	5	Gasket Cylinder Head
27549S		4159	10	Gasket Breather	272163S		4121	5	Gasket Cylinder Head
27803S		4177	10	Gasket Breather	272199S		4198	5	Gasket Intake
27987S	5001	4108	5	Filter A/C Foam	272200S		4122	5	Gasket Cylinder Head
63709		4164	10	Bushing Valve Guide	272235S	5047, 5107	4107	6	Air Filter Element
65704	5020			Plunger	272403S	5053, 5109	4142	5	Pre-cleaner
66538S		4124	5	Boot Spark Plug	272409S		4179	10	Gasket Fuel Tank
89838S	5023			Spark Plug Wrench	272477S	5075	4199	5	Pre-cleaner
89966	5006			Muffler 2-3 HP H/S	272490S	5050, 5052, 5110	4111	6	Pre-cleaner
95162S		4171	5	Clamp Hose	272536S		4123	5	Gasket Cylinder Head
100002	5041, 5109, 5110			Fuel Stabilizer	272538WS		4168	5	Carburetor Diaphragm
100005	5107, 5108, 5111, 5106			Oil 20 oz.	272653S		4156	5	Gasket Air Cleaner
100028	5109, 5110, 5111			Oil 48 oz.	272996		4172	5	Gasket Fuel Tank
100030C	5112, 5113			Snow Oil	273113S		4200	5	Gasket Intake
100031	5058	4127	50	Fuel Stabilizer	273185S	5055			Pre-cleaner
100056	5106, 5107, 5108, 5111, 5112, 5113			Fuel Stabilizer	273356S	5059, 5108	4201	5	Pre-cleaner
222698S	5002, 5012	4144, 4181	50, 10	Flywheel Key	273638S	5063			Pre-cleaner
260875		4113	5	Governor Spring	280399S	5054			Rope
270026		4157	10	Carburetor Diaphragm	280406S				Rope
270511		4169	5	Float Bowl Gasket	280439S		4170	5	Pulley-Starter
270528S	5045	4133	4	Air Filter Element	281165S		4202	5	Gasket Float Bowl
270579S	5009	4104	5	Air Filter Element	281370S		4203	5	Seal Dipstick Tube
270843S	5046	4134	4	Air Filter Element	281505S		4204	5	Pawl Ratchet
271466		4109	4	Filter Pre-cleaner	281658S	5061			Oil Fill Plug
271702S		4183	10	Gasket Crankcase	291675S		4115	5	Seal Oil
					294599S	5011			Muffler 7-8 HP riders

12-2 SHOP PACKS INDEX

SHOP PACKS INDEX

RED BOX P/N	DIY P/N	SHOP PACK P/N	SHOP PACK QTY.	DESCRIPTION	RED BOX P/N	DIY P/N	SHOP PACK P/N	SHOP PACK QTY.	DESCRIPTION
294628	5012, 5020			Breaker Points	499486S	5063			Air Filter Cartridge
298090S	5018	4105	5	Filter Fuel	499730	5062, 5112, 5062	4175, 4176	24, 8	Platinum Spark Plug L-Head
299819S		4116	5	Seal Oil	690610	5059, 5108	4196	4	Air Filter Cartridge
391086S		4117	5	Seal Gear Reduction	691035	5065	4129	5	Fuel Filter
391483S		4118	5	Seal Oil	691613		4205	5	Gasket Exhaust
393152	5054, 5042	4119	5	Grip-Starter Rope	691643	5073	4195	5	Air Filter Cartridge
393957S		4106	4	Air Filter Cartridge	691667	5075	4166	5	Air Filter Cartridge
394018S	5050	4135	4	Air Filter Cartridge	691959	5072			Key Set Indak
394019S	5052, 5110	4136	4	Air Filter Cartridge	692046	5068			Gas Cap
394358S		4112	5	Filter Fuel	692213		4161	10	Gasket Crankcase
394569	5019			Muffler Lo Tone 3-4HP	692218		4162	10	Gasket Crankcase
394970	5025			Ignition Magnetron Retrofit Kit	692221		4165	10	Gasket Crankcase
396424S	5026	4137	4	Air Filter Cartridge	692226		4163	10	Gasket Crankcase
397795S	5027	4102	5	Air Filter Cartridge	692232		4182	10	Gasket Crankcase
397974S	5044	4131, 4149	5, 20	Cap Fuel Tank	692241		4158	10	Gasket Fuel Tank
399806S	5048	4138	4	Air Filter Cartridge	693058		4152	5	Gear, Pinion (Note 2)
399877S	5028	4103	5	Air Filter Cartridge	693059		4155	5	Gear, Pinion (Note 1)
490179	5010			Starter Rewind Spring	694385	5066, 5111	4173, 4174	24, 8	Platinum Spark Plug OHV
490652		4130	5	Grip-Starter Rope	694394		4178	5	Primer Carburetor
491055S	5108			Spark Plug	694395		4180	5	Primer Carburetor
491056S		4153	12	Oil Filter	695327	5111			Fuel Filter
491435S		4146	5	Air Filter Cartridge	695666	5070			Premium Fuel Filter
491588S	5043, 5106	4101	5	Air Filter Cartridge	695667	5069, 5111			Premium Air Filter
492889	5073, 5060	4148	5	Filter Pre-cleaner	695708		4194	5	Gear Pinion
492932S	5049, 5111	4154	12	Oil Filter	695951	5071			Key Touch-N-Mow
493537S	5064	4147	5	Premium Pre-cleaner	696854	5076	4206	12	Oil Filter, Extended Life
493982S		4167	5	Cap Fuel Tank	710266	5074			Air Filter Cartridge
494408		4128	5	Primer Carburetor	710268	5074			Pre-cleaner
494511S	5060	4145	4	Air Filter Cartridge	802592S	5113			Spark Plug
494625	5021			Carb. Overhaul Kit	802592S	5106, 5107, 5109, 5110, 5020			Spark Plug
496894S	5053, 5109	4139	4	Air Filter Cartridge	805113		4140	5	Air Filter Cartridge
497725S	5055	4197	4	Air Filter Cartridge	805267S		4143	5	Pre-cleaner
497929S	5057	4132, 4150	5, 20	Cap Fuel Tank					





























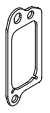
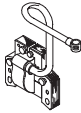

Note 1: For use with aluminum ring gear equipped engines.
 Note 2: For use with plastic ring gear equipped engines.

Model Numbers	Page Number
21000 - 82200 (Type Nos. 0111-0200, 2035-2099, 8000-8199)	13-2
82200 (Type Nos. 0300-0400, 2135-2199, 4000-5000, Above 8200) - 90700	13-4
91200 - 94900	13-6
95500 -104700	13-8
11A600 -113400	13-10
113900 - 12C700	13-12
12C800 - 12J800	13-14
12L800 - 121H00	13-16
121400 - 124H00	13-18
124K00 - 127800	13-20
128400 - 131700	13-22
131900 - 136200	13-24
137200 - 19E400	13-26
19F400 - 195400 (Type Nos. 0100-0400, 2000-2099)	13-28
195400 (Type Nos. 0600-1999, Above 2100) - 201400	13-30
202400 - 226400	13-32
233400 - 255400	13-34
255700 - 28D700	13-36
28E700 - 282700	13-38
283700 - 300400	13-40
302400 - 351400	13-42
351700 - 404400	13-44
404700 - 460700	13-46
461700 - 587400	13-48
Reference Notes	13-50

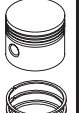

















13-2 GENUINE PARTS QUICK REFERENCE

 Engine Model Series	AIR FILTER		FUEL FILTER/OIL FILTER		CARBURETOR				CONN. ROD ASSY.	FUEL TANK CAP	GASKETS				
	Foam (535)	 Cartridge  Pre-Cleaner	 Fuel Filter	 Oil Filter	 Dia- phragm	 Float Valve	 Needle Valve	 Over- haul/ Repair Kit	 Rod Assy.	 Tank Cap	 Air Cleaner	 Carb. to Cylin- der	 Cylin- der Head	 Oil Sump/ Cover	 Set
21000	-	-	696918	-	-	-	-	697008	696878	696921	-	696867 696868	696865	696866	-
60100	27987S	392308S 396424S 271466	-	-	-	-	299059	-	294300	493982S	27660 Note A 271755 Note B	27355S (2 used)	272167	692218 .015 270895 .005 270896 .009	495602
80100	27987S	-	-	-	-	-	299059	-	294367	493982S	27660 Note A	27355S (2 used)	272167	692218 .015 270895 .005 270896 .009	495602
80200 Type Nos. 0010-2200 8000-8200 Above 9000	27987S	392308S 396424S 271466	-	-	270026	-	299060	495606	294367	493982S	27660 Note A 271077 Note B 271755 Note B	27355S (2 used)	272167	692218 .015 270895 .005 270896 .009	495602
80200 Type Nos. 2201-4900 8901-8999	-	491588S 491435S	-	-	270026	-	691777	495606 Check Codes	294367	494559	271935S	273113S (2 used)	272167	692218 .015 270895 .005 270896 .009	495602
80300	27987S	392308S 396424S 271466	-	-	-	293478	399619 Note G	398992 Note F	294367	69221	27660 Note A 271077 Note B 271139S Note B	27355S (1 used)	272167	692218 .015 270895 .005 270896 .009	495602
80400	27987S	392308S 396424S 271466	-	-	-	293478	399619 Note G	398992 Note F	294367	69221	27660 Note A 271077 Note B 271139S Note B	27355S (1 used)	272167	692218 .015 270895 .005 270896 .009	495602
81200	27987S	392308S 396424S 271466	-	-	270026	-	299060	495606	294367	493982S	27660 Note A 271077 Note B 271139S Note B	27355S (2 used)	272167	692218 .015 270895 .005 270896 .009	495602
81300	27987S	392308S 396424S 271466	-	-	-	293478	399619 Note G	398992 Note F	294367	69221	27660 Note A 271077 Note B 271139S Note B	27355S (1 used)	272167	692218 .015 270895 .005 270896 .009	495602
81400	27987S	392308S 396424S 271466	-	-	-	293478	399619 Note G	398992 Note F	294367	69221	27660 Note A 271077 Note B 271139S Note B	27355S (1 used)	272167	692218 .015 270895 .005 270896 .009	495602
82200 Type Nos. 0111-0200 2035-2099 8000-8199	-	396424S 271466	-	-	270026	-	299060	495606	294367	493982S	271139S Note B	27355S (2 used)	272167	692218 .015 270895 .005 270896 .009	495602

GAS-KETS	IGNITION				MUFFLER	OIL SEALS	PISTON RINGS & PISTON ASSY.			REWIND STARTER					VALVES	
																
Valve Cover	Armature	Breaker Assy.	Condenser	Fly-wheel Key	Muffler Assy.	Oil Seals	Ring Set	Piston Assy.	Clutch	Grip	Pulley	Rope	Spring	Valves		
696931	696877	-	-	-	696874	696879 Mag	696933	Std.	696932	-	-	-	696973	-	696862 EX 696864 IN	
27549S	298502 Note D 496914 Note E	294628	See Breaker Assy.	222698S	89966 493288	299819S Mag 299819S PTO	294232 294224 294225 294226 297201	Std. .010 .020 .030 Chrome	295587 295588 295589 295590 -	399671	393152	280439S	66734 Note C	490179	296676 EX 296677 IN	
27549S	298502 Note D 496914 Note E	294628	See Breaker Assy.	222698S	89966 493288	299819S Mag 299819S PTO	294232 294224 294225 294226 297201	Std. .010 .020 .030 Chrome	295587 295588 295589 295590 -	399671	393152	280439S	66734 Note C	490179	296676 EX 296677 IN	
27549S	298502 Note D 496914 Note E	294628	See Breaker Assy.	222698S	89966 493288	299819S Mag 299819S PTO	294232 294224 294225 294226 297201	Std. .010 .020 .030 Chrome	295587 295588 295589 295590 -	399671	393152	280439S	66734 Note C	490179	296676 EX 296677 IN	
27549S	496914 Note E	-	-	222698S	691360 493288	299819S Mag 299819S PTO	294232 294224 294225 294226 297201	Std. .010 .020 .030 Chrome	295587 295588 295589 295590 -	399671	393152	280439S	66734 Note C	490179	296676 EX 296677 IN	
27549S	298502 Note D 496914 Note E	294628	See Breaker Assy.	222698S	89966 493288	299819S Mag 299819S PTO	294232 294224 294225 294226 297201	Std. .010 .020 .030 Chrome	295587 295588 295589 295590 -	399671	393152	280439S	66734 Note C	490179	296676 EX 296677 IN	
27549S	298502 Note D 496914 Note E	294628	See Breaker Assy.	222698S	89966 493288	299819S Mag 299819S PTO	294232 294224 294225 294226 297201	Std. .010 .020 .030 Chrome	295587 295588 295589 295590 -	399671	393152	280439S	66734 Note C	490179	296676 EX 296677 IN	
27549S	298502 Note D 496914 Note E	294628	See Breaker Assy.	222698S	89966 493288	299819S Mag 299819S PTO	294232 294224 294225 294226 -	Std. .010 .020 .030 Chrome	295455 295456 295457 295458 -	399671	393152	280439S	66734 Note C	490179	494187 EX 296677 IN	
27549S	298502 Note D 496914 Note E	294628	See Breaker Assy.	222698S	89966 493288	299819S Mag 299819S PTO	294232 294224 294225 294226 -	Std. .010 .020 .030 Chrome	295455 295456 295457 295458 -	399671	393152	280439S	66734 Note C	490179	494187 EX 296677 IN	
27549S	298502 Note D 496914 Note E	294628	See Breaker Assy.	222698S	89966 493288	299819S Mag 299819S PTO	294232 294224 294225 294226 -	Std. .010 .020 .030 Chrome	295455 295456 295457 295458 -	399671	393152	280439S	66734 Note C	490179	494187 EX 296677 IN	
27549S	496914 Note E	-	-	222698S	691360 493288	299819S Mag 299819S PTO	294232 294224 294225 294226 -	Std. .010 .020 .030 Chrome	295455 295456 295457 295458 -	399671	393152	280439S	66734 Note C	490179	262580 EX 296677 IN	

















13-4 GENUINE PARTS QUICK REFERENCE











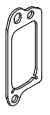
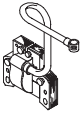

 Engine Model Series	AIR FILTER		FUEL FILTER/OIL FILTER		CARBURETOR				CONN. ROD ASSY.	FUEL TANK CAP	GASKETS				
	Foam	 Cartridge  Pre-Cleaner	 Fuel Filter	 Oil Filter	 Dia- phragm	 Float Valve	 Needle Valve	 Over- haul/ Repair Kit	 Rod Assy.	 Tank Cap	 Air Cleaner	 Carb. to Cylin- der	 Cylin- der Head	 Oil Sump/ Cover	 Set
82200 Type Nos. 0300-0400 2135-2199 4000-5000 Above 8200	-	491588S 491435S	-	-	270026	-	691777	495606	294367	494559	271935S	273113S	272167	692218 .015 270895 .005 270896 .009	495602
82300	-	396424S 271466	-	-	-	293478	399619 Note G	398992 Note F	294367	69221	271139S	27355S (1 used)	272167	692218 .015 270895 .005 270896 .009	495602
82400	-	396424S 271466	-	-	-	293478	399619 Note G	398992 Note F	294367	69221	271139S	27355S (1 used)	272167	692218 .015 270895 .005 270896 .009	495602
83400	-	491588S -	-	-	-	398188	493765	498260	294367	-	272296	273113S	272167	692218 .015 270895 .005 270896 .009	495602
85400	-	710265 710267	-	-	-	715075	715293 Idle	715082	715055	710490	-	710060	710137	710141	715032
9B900	272235S	-	-	-	495770	-	-	-	294201	493982S Metal 497929S Plastic	271139S	-	Note 2	692218 .015 270895.005 270896.009	298989
9C900	272235S	-	-	-	495770 (Pump)	-	-	-	294201	493982S Metal 497929S Plastic	271139S	270345S	Note 2	692218 .015 270895 .005 270896 .009	298989
9D900	272235S	-	-	-	495770	-	-	-	294201	493982S Metal 497929S Plastic	271139S	-	692288	692218 .015 270895 .005 270896 .009	298989
9K400	-	494511S 492889	298090S	-	-	398188	-	498260	294367	692662 692665	272948S	273113S	692288	270895	496865
90100	272235S	-	-	-	-	-	299060	-	294367	493982S	271755	27355S (1 used) or (2 used)	272536S	692218 .015 270895 .005 270896 .009	495602
90200	-	491588S 491435S	-	-	272538S	-	691777	-	294367	494559	271935S	273113S (2 used)	272536S	692218 .015 270895 .005 270896 .009	495605
90700	-	397795S 399039	-	-	-	398188	Note I	Note I	294201	397974S	272296	270345S	272536S	692218 .015 270895 .005 270896 .009	298989

GAS-KETS	IGNITION				MUFFLER	OIL SEALS	PISTON RINGS & PISTON ASSY.			REWIND STARTER					VALVES	
	Valve Cover	Armature	Breaker Assy.	Condenser			Fly-wheel Key	Muffler Assy.	Oil Seals	Ring Set	Piston Assy.	Clutch	Grip	Pulley		Rope
27549S	496914 Note E	-	-	222698S	691360 493288	299819S Mag 299819S PTO	294232 294224 294225 294226 297201	Std. .010 .020 .030 Chrome	295455 295456 295457 295458 -	399671	393152	280439S	66734 Note C	490179	262580 296677	EX IN
27549S	496914 Note E	-	-	222698S	691360 493288	299819S Mag 299819S PTO	294232 294224 294225 294226 297201	Std. .010 .020 .030 Chrome	295455 295456 295457 295458 -	399671	393152	280439S	66734 Note C	490179	262580 296677	EX IN
27549S	496914 Note E	-	-	222698S	691360	299819S Mag 299819S PTO	294232 294224 294225 294226 297201	Std. .010 .020 .030 Chrome	295455 295456 295457 295458 -	399671	393152	280439S	66734 Note C	490179	262580 296677	EX IN
27549S	496914 Note E	-	-	222698S	-	299819S Mag 299819S PTO	294232 294224 294225 294226 297201	Std. .010 .020 .030 Chrome	295587 295588 295589 295590 -	399671	393152	280439S	66734 Note C	490179	296676 296677	EX IN
710024	715023	-	-	710037	715487	710103 Mag 710140 PTO	715060 715061 715062 - -	Std. .010 .020 .030 -	715063 715064 715065 -	-	393152	493824	280399S Note C	493824	715002 715003	EX IN
695890	496914 Note E	-	-	222698S	Note 1	299819S Mag 391483S PTO	Note 2 Ring Set and Piston Assembly			Note 2	Note 1	Note 1	Note 1	Note 1	296676 296677	EX IN
695890	496914 Note E	-	-	222698S	692307	299819S Mag 391483S PTO	See Parts List			Note 2	Note 1	Note 1	Note 1	Note 1	296676 296677	EX IN
695890	496914 Note E	-	-	222698S	Note 1	299819S Mag 391483S PTO	498680 498681 498682 498683	Std. .010" .020" .030"	498668 498669 498670 498671	-	691915	499901	692259	Note 3	296676 296677	EX IN
27549S	496914	-	-	222698S	692365	299819S Mag 692020 PTO	695169 695171 695172 695173	Std. .010" .020" .030"	498676 498677 498676 498679	-	691915	499901	280399S	499901	497871 296677	EX IN
27549S	496914 Note E	-	-	222698S	493288	299819S Mag 299819S PTO	298982 298983 298984 298985 299742	Std. .010 .020 .030 Chrome	298904 298905 298906 298907 -	399671	393152	280439S	280406S Note C	490179	296676 296677	EX IN
27549S	496914 Note E	-	-	222698S	493288	299819S Mag	298982 298983 298984 298985 299742	Std. .010 .020 .030 Chrome	298904 298905 298906 298907 -	399671	393152	280439S	280406S Note C	490179	296676 296677	EX IN
695890	496914 Note E	-	-	222698S	394569S 692307	299819S Mag 391483S PTO	298982 298983 298984 298985 299742	Std. .010 .020 .030 Chrome	298904 298905 298906 298907 -	399671	393152 Note O	280439S Note NX	280406S Note C	490179 Note M	296676 296677	EX IN

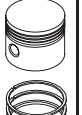



























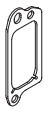
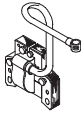



13-6 GENUINE PARTS QUICK REFERENCE

 Engine Model Series	AIR FILTER		FUEL FILTER/OIL FILTER		CARBURETOR				CONN. ROD ASSY.	FUEL TANK CAP	GASKETS				
	Foam	 Cartridge  Pre-Cleaner	 Fuel Filter	 Oil Filter	 Dia- phragm	 Float Valve	 Needle Valve	 Over- haul/ Repair Kit	 Rod Assy.	 Tank Cap	 Air Cleaner	 Carb. to Cylin- der	 Cylin- der Head	 Oil Sump/ Cover	 Set
91200	-	396424S 491588S 491435S	-	-	272538S	-	691777	-	294367	494559	271935S	273113S (2 used)	272536S	692218 .015 270895 .005 270896 .009	495605
91400	-	494511S 492889	-	-	-	398188	-	498260	294367	-	272948S	273113S	692288	270895	496865
91700	-	397795S 399039	-	-	-	398188	Note I	Note I	294201	397974S	272296	270345S	272536S	692218 .015 270895 .005 270896 .009	298989
92200	-	491588S 491435S	-	-	272538S	-	691777	495606	294367	494559	271935S	273113S	692288	692218 .015 270895 .005 270896 .009	495605
92500 Type Nos. Above 0600	270579S 272235S Note I	396424S 271466	-	-	299637	-	299060 395508	494622	294201	493982S	271077 Note B 271139S Note A	270345S	272536S	692218 .015 270895 .005 270896 .009	298989
92900 Type Nos. Above 0500	270579S 272235S	392308S 396424S 271466	-	-	391681	-	299060 395508	494623	294201	493982S	271077 Note B 271139S Note A	270345S	272536S	692218 .015 270895 .005 270896 .009	298989
93200	-	491588S 491435S	-	-	272538S	-	691777	495606	294367	494559	271935S	273113S	692288	692218 .015 270895 .005 270896 .009	495605
93400	-	494511S 492889	298090S	-	-	398188	493765	498260	294367	493988S	272948S	273113S	692228	692218 .015 270895 .005 270896 .009	496865
93500	270579S	392308S 271466	-	-	299637	-	395508	494622	294201	493982S	271077 Note B 271139S Note A	270345S	272536S	692218 .015 270895 .005 270896 .009	298989
93900	272235S	-	-	-	391681 Note S	-	395508 Note L	494623 Note L	294201	493982S	271139S	270345S	272536S	692218 .015 270895 .005 270896 .009	298989
94200	-	491588S 491435S	-	-	272538S	-	-	-	294367	494559	271935S	273113S	692288	692218 .015 270895 .005 270896 .009	495605
94500	270579S	-	-	-	299637	-	395508	494622	294201	493982S	271139S	270345S	272536S	692218 .015 270895 .005 270896 .009	298989
94900	270579S	-	-	-	391681	-	299060 395508	494623	294201	493982S	271139S	270345S	272536S	692218 .015 270895 .005 270896 .009	298989

GAS-KETS	IGNITION				MUFFLER	OIL SEALS	PISTON RINGS & PISTON ASSY.			REWIND STARTER					VALVES	
																
Valve Cover	Armature	Breaker Assy.	Condenser	Fly-wheel Key	Muffler Assy.	Oil Seals	Ring Set	Piston Assy.	Clutch	Grip	Pulley	Rope	Spring	Valves		
27549S	496914 Note E	-	-	222698S	493288 691360	299819S Mag	298982 298983 298984 298985 299742	Std .010 .020 .030 Chrome	298904 298905 298906 298907 -	399671	393152	280439S	280406S Note C	490179	296676 296677	EX IN
27549S	496914	-	-	222698S	-	299819S Mag 299819S PTO	498680 498681 498682 498683	Std .010 .020 .030	498668 498669 498670 498671	-	691915	499901	692259	499901	497871 296677	EX IN
695890	496914 Note E	-	-	222698S	692307	299819S Mag 391483S PTO	298982 298983 298984 298985 299742	Std. .010 .020 .030 Chrome	298904 298905 298906 298907 -	399671	393152 Note O	280439S Note NX	280406S Note C	490179 Note M	296676 296677	EX IN
27549S	496914 Note E	-	-	222698S	691360	299819S Mag 692020 PTO	See Parts List		399671	393152	280439S	280406S Note C	490179	296676 296677	EX IN	
695890	298502 Note D 496914 Note E	294628	See Breaker Assy.	222698S	394569S 692307	299819S Mag 391483S PTO	298982 298983 298984 298985 299742	Std. .010 .020 .030 Chrome	298904 298905 298906 298907 -	399671	393152 Note O	280439S Note NX	280406S Note C	490179 Note M	296676 296677	EX IN
695890	298502 Note D 496914 Note E	294628	See Breaker Assy.	222698S	394569S 692307	299819S Mag 391483S PTO	298982 298983 298984 298985 299742	Std. .010 .020 .030 Chrome	298904 298905 298906 298907 -	399671	393152 Note O	280439S Note NX	280406S Note C	490179 Note M	296676 296677	EX IN
27549S	496914	-	-	222698S	493288	299819S Mag 299819S PTO	See Parts List		399671	393152	281336S	280406S Note C	490179	296676 296677	EX IN	
27549S	496914	-	-	222698S	692365	299819S Mag 692020 PTO	399067 399014 399015 399016 -	Std .010 .020 .030 -	496869 393820 393821 393822 -	399671	393152	280439S	280406S Note C	490179	497871 296676	EX IN
695890	298502	294628	See Breaker Assy.	222698S	394569S 692307	299819S Mag 391483S PTO	298982 298983 298984 298985 299742	Std. .010 .020 .030 Chrome	298904 298905 298906 298907 -	399671	393152 Note O	280439S Note NX	280406S Note C	490179 Note M	296676 296677	EX IN
695890	496914	-	-	222698S	394569S 692307	299819S Mag 391483S PTO	298982 298983 298984 298985 299742	Std. .010 .020 .030 Chrome	298904 298905 298906 298907 -	399671	393152 Note O	280439S Note NX	280406S Note C	490179 Note M	296676 296677	EX IN
27549S	496914	-	-	222698S	493288	299819S Mag 299819S PTO	498680 498681 498682 498683	Std. .010 .020 .030	498668 498669 498670 498671	-	393152	499901	692259	Note 3	296676 296677	EX IN
695890	298502 Note D 496914 Note E	294628	See Breaker Assy.	222698S	692307	299819S Mag 391483S PTO	298982 298983 298984 298985 299742	Std. .010 .020 .030 Chrome	298904 298905 298906 298907 -	399671	393152 Note O	280439S Note NX	66734 Note C	490179 Note M	296676 296677	EX IN
695890	298502	294628	See Breaker Assy.	222698S	692307	299819S Mag 391483S PTO	298982 298983 298984 298985 299742	Std. .010 .020 .030 Chrome	298904 298905 298906 298907 -	399671	393152 Note O	280439S Note NX	66734 Note C	490179 Note M	296676 296677	EX IN

















13-8 GENUINE PARTS QUICK REFERENCE

 Engine Model Series	AIR FILTER		FUEL FILTER/OIL FILTER		CARBURETOR				CONN. ROD ASSY.	FUEL TANK CAP	GASKETS				
	Foam	 Cartridge  Pre-Cleaner	 Fuel Filter	 Oil Filter	 Dia- phragm	 Float Valve	 Needle Valve	 Over- haul/ Repair Kit	 Rod Assy.	 Tank Cap	 Air Cleaner	 Carb. to Cylin- der	 Cylin- der Head	 Oil Sump/ Cover	 Set
95500	270579S	-	-	-	299637	-	395508	494622	294201	493982S	271139S	270345S	272536S	692218 .015 270895 .005 270896 .009	298989
95700 (2-Cycle)	-	397795S ----- 399039	-	-	-	802611 Note P	-	802618 Note Q	-	800006 Note R	800040	800040	-	800055	802558
95900	272235S	-	-	-	495770	-	-	-	294201	493982S	271139S	270345S	272536S	692218 .015 270895 .005 270896 .009	298989
96500	272235S	-	-	-	299637	-	395508	494622	294201	493982S	271139S	270345S	272536S	692218 .015 270895 .005 270896 .009	298989
96700 (2-Cycle)	-	397795S ----- 399039	-	-	-	802611 Note P	-	802618 Note Q	-	800006 Note R	800040	800040	-	800055	802558
96900	272235S	-	-	-	495770	-	-	-	294201	493982S	271139S	-	272536S	692218 .015 270895 .005 270896 .009	298989
98900	272235S	-	-	-	495770	-	-	-	294201	493982S	271139S	-	272536S	692218 .015 270895 .005 270896 .009	298989
99700	-	- ----- 273185S	-	-	-	398188	493765	498260	493049	397974S	See Illus. Parts List	-	272314	272324	See Illus. Parts List
10A900	272235S	-	-	-	495770	-	494409	-	496792S	493982S	271139S	270345S	692288	692218 .015 270895 .005 270896 .009	298989
10B900	272235S	-	-	-	495770	-	-	-	496792S	493982S Metal ----- 497929S Plastic	271139S	270345S	692288	270895	298989
10D900	272235S	-	-	-	495770	-	-	-	496792S	497929S	271139S	270345S	692288	270895	298989
10E900	-	-	-	-	-	-	-	-	496792S	497929S	271139S	270345S	692288	270895	-
104700	-	491950 ----- 272218	-	-	-	492186	492277 (Idle)	492487 Note J	493204	491367S	-	272159	272133	272132	492872









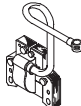

GAS-KETS	IGNITION				MUFFLER	OIL SEALS	PISTON RINGS & PISTON ASSY.			REWIND STARTER					VALVES	
																
Valve Cover	Arma-ture	Breaker Assy.	Con-denser	Fly-wheel Key	Muffler Assy.	Oil Seals	Ring Set	Piston Assy.	Clutch	Grip	Pulley	Rope	Spring	Valves		
695890	298502	294628	See Breaker Assy.	222698S	692307	299819S Mag 391483S PTO	298982 298983 298984 298985 299742	Std. .010 .020 .030 Chrome	298904 298905 298906 298907 -	-	393152	299948	66734 Note C	390066	296676 296677	EX IN
-	496914	-	-	222698S	394569S 692307	299819S Mag 391483S PTO	298982 298983 298984 298985 299742	Std. .010 .020 .030 Chrome	298904 298905 298906 298907 -	399671	393152	280439S	280406S Note C	490179	296676 296677	EX IN
695890	496914	-	-	222698S	394569S 692307	299819S Mag 391483S PTO	298982 298983 298984 298985 299742	Std. .010 .020 .030 Chrome	298904 298905 298906 298907 -	399671	393152	280439S	280406S Note C	490179	296676 296677	EX IN
695890	496914	-	-	222698S	394569S 692307	299819S Mag 391483S PTO	298982 298983 298984 298985 299742	Std. .010 .020 .030 Chrome	298904 298905 298906 298907 -	399671	393152	280439S	280406S Note C	490179	296676 296677	EX IN
-	802574	-	-	800036	802500 802580 (DIN Guard)	802525 Mag 802526 PTO	802514	Std.	802515	-	490652	800011	280399S Note C	802508	- EX - IN	
695890	802574	-	-	800036	802500 802580 (DIN Guard)	802525 Mag 802526 PTO	802514	Std.	802515	-	490652	800011	280399S Note C	802508	- EX - IN	
695890	496914	-	-	222698S	394569S 692307	299819S Mag 391483S PTO	298982 298983 298984 298985 299742	Std. .010 .020 .030 Chrome	298904 298905 298906 298907 -	399671	393152	281336S	280406S Note C	490179	296676 296677	EX IN
272481S	802574	-	-	222698S	494717	299819S Mag 399781S PTO	493782	Std.	493781	-	393152	493824	280399S Note C	491889	493778 493777	EX IN
695890	496914	-	-	222698S	394569S 692307	299819S Mag 391483S PTO	298982 298983 298984 298985 299742	Std. .010 .020 .030 Chrome	298904 298905 298906 298907 -	399671	393152	281336S	280406S Note C	490179	296676 296677	EX IN
695890	496914	-	-	222698S	394569S	299819S Mag 391483S PTO	498680 499681 498682 498683	Std. .010 .020 .030	498668 498669 498670 498671	-	691915	499901	692259	499901	296676 296677	EX IN
695890	496914	-	-	222698S	692307	299819S Mag 391483S PTO	498680 499681 498682 498683	Std. .010 .020 .030	498668 498669 498670 498671	-	691915	499901	692259	499901	296676 296677	EX IN
695890	496914	-	-	222698S	394569S	299819S Mag 391483S PTO	498680 499681 498682 498683	Std. .010 .020 .030	498668 498669 498670 498671	399671	691915 715257	498144	692259	498144	296676 296677	EX IN
272131 (Rocker Cover)	491760 802574	-	-	222698S	492746	399781S Mag 399781S PTO	492766 492883 492884 492885	Std. .010 .020 .030	492767 492886 492887 492888	-	393152	493824	280406S Note C	491889	492770 492769	EX IN

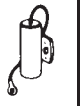
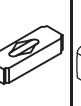
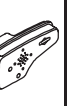

13-10 GENUINE PARTS QUICK REFERENCE

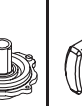
 Engine Model Series	AIR FILTER		FUEL FILTER/OIL FILTER		CARBURETOR				CONN. ROD ASSY.	FUEL TANK CAP	GASKETS				
	Foam	 Cartridge  Pre-Cleaner													
11A600	-	491588S 493537S	-	-	-	398188	-	692703	692671	397974S	692667	692668	695166	692232	694090
11C600	-	491588S 493537S	-	-	-	398188	-	692703	692671	397974S	692667	692668	695166	692549	695155
110400	-	491588S 697029 493537S 273356S	694485	-	-	398188	-	695157	499424	493988S	272948S	692555	695166	692549	695155
110600	-	493537S	-	-	-	398188	-	692703	692671	692046	691894	692668	695166	692232	694090
110700	-	397795S 399039	-	-	-	398188	Note I	Note I	490566	397974S	272296	270844	272171	692218 .015 270895 .005 270896 .009	391662
110900	270848	392308S 396424S 271466	-	-	391681	-	299060 395508	494623	490566	493982S	271077 Note B 271139S Note A	270844	272171	692218 .015 270895 .005 270896 .009	391662
111400	-	491588S 697029 273356S 493537S	-	-	-	398188	-	695157	499424	694261 493988S	272948S	692555	695166	692549	695155
111600	-	697029 273356S	-	-	-	398188	-	692703	692671	692046	691894	692668	695166	692232	694090
112200 Type Nos. 0016-0799	27987S	392308S 396424S 271466	-	-	270026	-	299060	495606	392939	394818S	27660 Note A 271077 Note B 271139S Note B	394732 (2 used)	272171	692218 .015 270895 .005 270896 .009	397147
112200 Type Nos. Above 0800	-	491588S 491435S	-	-	270026	-	691777	495606	392939	494559	271935S	273113S (2 used)	272171	692218 .015 270895 .005 270896 .009	397147
112700	-	397795S -	-	-	-	398188	Note I	Note I	490566	397974S	272296	270844	272171	692218 .015 270895 .005 270896 .009	391662
112900	270848	396424S 271466	-	-	391681	-	395508	494623	490566	493982S	271077 Note B 271139 Note A	270844	272171	692218 .015 270895 .005 270896 .009	391662
113400	-	697029 273356S	694485	-	-	398188	-	695157	499424	694261	693458	692555	695166	692549	695155

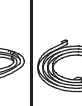















GENUINE PARTS QUICK REFERENCE 13-11

GAS-KETS	IGNITION				MUFFLER	OIL SEALS	PISTON RINGS & PISTON ASSY.			REWIND STARTER					VALVES	
																
Valve Cover	Arma- ture	Breaker Assy.	Con- denser	Fly- wheel Key	Muffler Assy.	Oil Seals	Ring Set	Piston Assy.	Clutch	Grip	Pulley	Rope	Spring	Valves		
272481S	802574	-	-	222698S	693982	299819S Mag 399781S PTO	499425 499426 499427 499428	Std. .010 .020 .030	499429 499430 499431 499432	-	281434S	498144	692259	498144	499642 499641	EX IN
691890	802574	-	-	-	696526	299819S Mag 399781S PTO	499425	Std.	499429	-	-	-	692259	-	499642 499641	EX IN
-	692605 802574	-	-	222698S	693593	299819S Mag 692550 PTO	499631 692785 692786 692787	Std. .010 .020 .030	690021 692788 692789 692790	-	715257	498144	693389 Cut to Length	Note 3	499642 499641	EX IN
272481S	802574	-	-	222698S	Note 1	299819S Mag 399781S PTO	499425 499426 499427 499428	Std. .010 .020 .030	499429 499430 499431 499432	-	281434S	498144	280399S Cut to Length	Note 3	499642 499641	EX IN
695890	496914	-	-	222698S	394569S 692307	299819S Mag 391483S PTO	391654 391656 391658 391660 392330	Std. .010 .020 .030 Chrome	391650 391651 391652 391653 -	399671	393152 Note O	280439S Note NX	280406S Note C	490179 Note M	212004 261233	EX IN
695890	298502 Note D 496914 Note E	294628	See Breaker Assy.	222698S	394569S 692307	299819S Mag 391483S PTO	391654 391656 391658 391660 392330	Std. .010 .020 .030 Chrome	391650 391651 391652 391653 -	399671	393152 Note O	280439S Note NX	280406S Note C	490179 Note M	212004 261233	EX IN
691890	802574	-	-	222698S	693593	299819S Mag 692550 PTO	499631 692785 692786 692787	Std. .010 .020 .030	499627 692788 692789 692790	-	691915 715257	498144	693389	498144	499642 499641	EX IN
272481S	802574	-	-	222698S	Note 1	299819S Mag 399781S PTO	499631 692785 692786 692787	Std. .010 .020 .030	499627 692788 692789 692790	-	281434S	498144	692259	Note 3	499642 499641	EX IN
27549S	298502 Note D 496914 Note E	294628	See Breaker Assy.	222698S	394569S 493288	299819S Mag 299819S PTO	391654 391656 391658 391660 392330	Std. .010 .020 .030 Chrome	391650 391651 391652 391653 -	399671	393152	280439S	66734 Note C	490179	212004 261233	EX IN
27549S	496914	-	-	222698S	691360 493288	299819S Mag 299819S PTO	391654 391656 391658 391660 392330	Std. .010 .020 .030 Chrome	391650 391651 391652 391653 -	399671	393152	280439S	280406S Note C	490179	212004 261233	EX IN
695890	496914	-	-	222698S	394569S	299819S Mag 391483S PTO	391654 391656 396461 396462 392330	Std. .010 .020 .030 Chrome	396455 396456 396457 396458 -	399671	393152	280439S	280406S Note C	490179	212004 261233	EX IN
695890	496914	-	-	222698S	394569S	299819S Mag 391483S PTO	391654 391656 396461 396462 392330	Std. .010 .020 .030 Chrome	396455 396456 396457 396458 -	399671	393152	280439S	280406S Note C	490179	212004 261233	EX IN
691890	802574	-	-	222698S	694429	299819S Mag 692550 PTO	499631 692785 692786 692787	Std. .010 .020 .030	499627 692788 692789 692790	-	715257	498144	693389	498144	499642 499641	EX IN











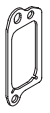
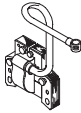



GENUINE PARTS . . . KEEP THE POWER IN POWER EQUIPMENT



13-12 GENUINE PARTS QUICK REFERENCE

 Engine Model Series	AIR FILTER		FUEL FILTER/OIL FILTER		CARBURETOR				CONN. ROD ASSY.	FUEL TANK CAP	GASKETS				
	Foam	 Cartridge  Pre-Cleaner	 Fuel Filter	 Oil Filter	 Dia- phragm	 Float Valve	 Needle Valve	 Over- haul/ Repair Kit	 Rod Assy.	 Tank Cap	 Air Cleaner	 Carb. to Cylin- der	 Cylin- der Head	 Oil Sump/ Cover	 Set
113900 Except Type No. 2999	270848	- - -	-	-	391681	-	395508	494623	490566	493982S	271139S	270844	272171	692218 .015 270895 .005 270896 .009	391662
114700	-	396424S 397795S - 271466 399039	-	-	-	398188	Note 1	Note 1	490566	397974S	272296	270844	272171	692218 .015 270895 .005 270896 .009	391662
114900	270848	396424S - 271466	-	-	391681	-	395508	494623	490566	493982S	271077 Note B 271139 Note A	270844	272171	692218 .015 270895 .005 270896 .009	391662
115400	-	491588S 494511S - 491435S 492889	298090S	-	-	715075	See Parts List	715439	715011	710490	-	710060	710021	710036	715032
117400	-	491588S - 491435S	298090S	-	-	715075	715293	715437	715011	710490	-	710060	710021	710036	715032
118400	-	491588S - 491435S	-	-	-	715868	715293	715874	715847	711215	710639	710060 710639	711129	711174	-
12A400	-	-	-	-	-	398188	-	695157	690124	695737	-	692555	695166	692549	695155
12A600	-	491588S - 493537S	-	-	-	398188	-	692703	499424	692046	692667	692668	695166	692232	694090
12A800	-	491588S	-	-	-	398188	493765	498260	490566	397974S	272653S	272199S	272200S	692232	-
12B400	-	-	-	-	-	398188	-	695157	690124	695737	-	692555	695166	692549	695155
12B600	-	491588S - 493537S	-	-	-	398188	-	692703	499424	692046	692667	692668	695166	692232	694090
12C400	-	-	-	-	-	398188	-	695157	690124	695737	-	692555	695166	692549	695155
12C600	-	491588S - 493537S	-	-	-	398188	-	692703	499424	692046	692667	692668	695166	692232	694090
12C700	-	491588S - 493537S	-	-	-	398188	-	Note 2	Note 2	397974S	272653S	272199S	692249	692232	497316

















GENUINE PARTS QUICK REFERENCE 13-13

GAS-KETS	IGNITION				MUFFLER	OIL SEALS	PISTON RINGS & PISTON ASSY.			REWIND STARTER					VALVES	
																
Valve Cover	Arma-ture	Breaker Assy.	Con-denser	Fly-wheel Key	Muffler Assy.	Oil Seals	Ring Set	Piston Assy.	Clutch	Grip	Pulley	Rope	Spring	Valves		
695890	298502 Note D Note E	294628	See Breaker Assy.	222698S	692307	299819S Mag 391483S PTO	391654 391656 391658 391660 392330	Std. .010 .020 .030 Chrome	391650 391651 391652 391653 -	399671	393152 Note O	280439S Note NX	280406S Note C	490179 Note M	212004 261233	EX IN
695890	-	-	-	222698S	394569S 692307	299819S Mag 391483S PTO	391654 391656 396461 396462 392330	Std. .010 .020 .030 Chrome	396455 396456 396457 396458 -	399671	393152 Note O	280439S Note NX	280406S Note C	490179 Note M	212004 261233	EX IN
695890	-	-	-	222698S	394569S 692307	299819S Mag 391483S PTO	391654 391656 396461 396462 392330	Std. .010 .020 .030 Chrome	396455 396456 396457 396458 -	399671	393152 Note O	280439S Note NX	280406S Note C	490179 Note M	212004 261233	EX IN
710024	715023	-	-	710037	715435	710000 Mag 710031 PTO	715016 715017 715018 -	Std. .010 .020 .030	715020 715021 715022 -	-	393152	493824	280399S Note C	493824	715002 715003	EX IN
710024	715023	-	-	710037	715435	710000 Mag 710031 PTO	715016 715017 715018 -	Std. .010 .020 .030	715020 715021 715022 -	-	490652	710274	66574	710270	715002 715003	EX IN
711112	711197	-	-	710037	711239	711139 Mag 710031 PTO	715016 715017 715018	Std. .010 .020	715850 715851 715852	-	490652	711231	711221	711229	715846 715845	EX IN
691890	695711	-	-	222698S	695735	299819S Mag 691952 PTO	499631 692785 692786 692787	Std. .010 .020 .030	690021 694167 694168 694169	-	695740	498144	693389	498144	499642 499641	EX IN
691890	802574	-	-	222698S	696526	299819S Mag 399781S PTO	499631 692785 692786 692787	Std. .010 .020 .030	690021 694167 694168 694169	-	281434S	498144	692259	498144	499642 499641	EX IN
272481S	802574	-	-	222698S	496106S	299819S Mag 399781S PTO	Note 2		-	393152	493824	280399S Note C	491889	262651S 262652 S	EX IN	
691890	695711	-	-	222698S	695735	299819S Mag 692550 PTO	499631 692785 692786 692787	Std. .010 .020 .030	499627 692788 692789 692790	-	695740	498144	693389	498144	499642 499641	EX IN
691890	802574	-	-	222698S	696526	299819S Mag 399781S PTO	499631 692785 692786 692787	Std. .010 .020 .030	690021 694167 694168 694169	-	281434S	498144	692259	498144	499642 499641	EX IN
691890	695711	-	-	222698S	695735	299819S Mag 691952 PTO	499631 692785 692786 692787	Std. .010 .020 .030	690021 694167 694168 694169	-	695740	498144	693389	498144	499642 499641	EX IN
691890	802574	-	-	222698S	696526	299819S Mag 399781S PTO	499631 692785 692786 692787	Std. .010 .020 .030	499627 692788 692789 692790	-	281434S	498144	692259	498144	499642 499641	EX IN
272481S	802574	-	-	222698S	496106S	299819S Mag 399781S PTO	Note 2 Ring Set and Piston Assembly		-	393152	493824	280399S Cut to Length	491889	262651S 262652S	EX IN	











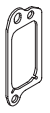
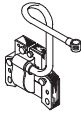



GENUINE PARTS . . . KEEP THE POWER IN POWER EQUIPMENT



13-14 GENUINE PARTS QUICK REFERENCE

 Engine Model Series	AIR FILTER		FUEL FILTER/OIL FILTER		CARBURETOR				CONN. ROD ASSY.	FUEL TANK CAP	GASKETS				
	Foam	 Cartridge  Pre-Cleaner	 Fuel Filter	 Oil Filter	 Dia- phragm	 Float Valve	 Needle Valve	 Over- haul/ Repair Kit	 Rod Assy.	 Tank Cap	 Air Cleaner	 Carb. to Cylin- der	 Cylin- der Head	 Oil Sump/ Cover	 Set
12C800	-	491588S 493537S	298090S	-	-	398188	-	Note 2	Note 2	397974S	272653S	-	692249	692232	497316
12D400	-	-	-	-	-	398188	-	695157	690124	695737	-	692555	695166	692549	695155
12D600	-	491588S 493537S	-	-	-	398188	-	692703	499424	692046	692667	692668	695166	692232	694090
12D800	-	491588S 493537S	298090S	-	-	398188	493765	498260	490566	397974S	272653S	272199S	272200S	692232	-
12E700	-	491588S 493537S	298090S	-	-	398188	493765	498260	490566	397974S	272653S	272199S	692249	692232	497316
12E800	-	491588S -	298090S	-	-	398188	493765	498260	490566	397974S	272653S	272199S	692249	692232	497316
12F700	-	491588S -	298090S	-	-	398188	493765	498260	490566	397974S	272653S	272199S	692249	692232	497316
12F800	-	491588S 493537S	298090S	-	-	398188	493765	498260 See Parts List	499424	397974S	272653S	272199S	692249	692232	497316
12G700	-	491588S 493537S	298090S	-	-	398188	493765	498260	499424	397974S	272653S	272199S	692249	692232	497316
12G800	-	491588S 493537S	298090S	-	-	398188	493765	498260	499424	397974S	272653S	272199S	692249	692232	497316
12H700	-	491588S 493537S	298090S	-	-	398188	493765	498260 Note 2	499424	397974S	272653S	272199S	692249	692232	497316
12H800	-	491588S 493537S	298090S	-	-	398188	-	498260	499424	397974S	272653S	272199S	692249	692232	497316
12J700	-	491588S 493537S	298090S	-	-	398188	-	498260	499424	397974S	272653S	272199S	692249	692232	497316
12J800	-	491588S 493537S	298090S	-	-	398188	493765	498260	499424	397974S	272653S	272199S	692249	692232	497316

















GENUINE PARTS QUICK REFERENCE 13-15

GAS-KETS	IGNITION				MUFFLER	OIL SEALS	PISTON RINGS & PISTON ASSY.			REWIND STARTER					VALVES
															
Valve Cover	Armature	Breaker Assy.	Condenser	Fly-wheel Key	Muffler Assy.	Oil Seals	Ring Set	Piston Assy.	Clutch	Grip	Pulley	Rope	Spring	Valves	
272481S	802574	-	-	222698S	Note 1	299819S Mag 399781S PTO	Note 2 Ring Set and Piston Assembly		-	281434S	498144	280399S Cut to Length	-	Note 1	
691890	695711	-	-	222698S	695735	299819S Mag 691952 PTO	499631 692785 692786 692787	Std. .010 .020 .030	499627 692788 692789 692790	-	695740	498144	693389	498144	499642 EX 499641 IN
691890	802574	-	-	222698S	696526	299819S Mag 399781S PTO	499631 692785 692786 692787	Std. .010 .020 .030	499627 692788 692789 692790	-	281434S	498144	692259	498144	499642 EX 499641 IN
272481S	802574	-	-	222698S	496106S	299819S Mag 399781S PTO	Note 2		-	393152	493824	280399S Note C	491889	262651S EX 262652 S IN	
272481S	802574	-	-	222698S	496106S 494343S	299819S Mag 399781S PTO	Note 2		-	281434S 393152	498144 493824	280399S Note C	498144 493824	262651S EX 262652 S IN	
272481S	802574	-	-	222698S	496106S	299819S Mag 399781S PTO	Note 2		-	393152	493824	280399S Note C	491889	262651S EX 262652 S IN	
272481S	802574	-	-	222698S	494343S 496106S	299819S Mag 399781S PTO	Note 2		-	393152	493824	280399S Note C	491889	262651S EX 262652 S IN	
272481S	802574	-	-	222698S	494343S 496106S	299819S Mag 399781S PTO	Note 2		-	393152	498144 493824	280399S Note C	493824	262651S EX 262652 S IN	
272481S	802574	-	-	222698S	496106S	299819S Mag 399781S PTO	Note 2		-	393152	493824	280399S Note C	491889	262651S EX 262652 S IN	
272481S	802574	-	-	222698S	494343S 496106S	299819S Mag 399781S PTO	Note 2		-	281434S 393152	498144 493824	280399S Note C	498144 491889	262651S EX 262652 S IN	
272481S	802574	-	-	222698S	692038	299819S Mag 399781S PTO	Note 2		-	281434S	498144	280399S Cut to Length	498144 Note 3	262651S EX 262652S INT	
272481S	802574	-	-	222698S	494343S	299819S Mag 399781S PTO	499425 499426 499427 499428	Std. .010 .020 .030	499429 499430 499431 499432	-	281434S	498144	280399S	498144	262651S EX 262652 S IN
272481S	802574	-	-	222698S	692038	299819S Mag 399781S PTO	Note 2		-	281434S	498144	280399S Cut to Length	498144 Note 3	262651S EX 262652S INT	
272481S	802574	-	-	222698S	692038	299819S Mag 399781S PTO	Note 2		-	281434S	498144	280399S Note C	498144 Note 3	262651S EX 262652 S IN	







GENUINE PARTS . . . THERE ARE NO SUBSTITUTES FOR THE REAL THING

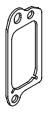

13-16 GENUINE PARTS QUICK REFERENCE

 Engine Model Series	AIR FILTER		FUEL FILTER/OIL FILTER		CARBURETOR				CONN. ROD ASSY.	FUEL TANK CAP	GASKETS				
	Foam	 Cartridge  Pre-Cleaner	 Fuel Filter	 Oil Filter	 Dia- phragm	 Float Valve	 Needle Valve	 Over- haul/ Repair Kit	 Rod Assy.	 Tank Cap	 Air Cleaner	 Carb. to Cylin- der	 Cylin- der Head	 Oil Sump/ Cover	 Set
12L800	-	491588S 493537S	298090S	-	-	398188	493765	498260	499424	397974S	272653S	272199S	692249	692232	497316
12S800	-	491588S -	298090S	-	-	398188	493765	498260	490566	397974S	272653S	272199S	692249	692232	497316
12T700	-	491588S -	298090S	-	-	398188	493765	498260	490566	397974S	272653S	272199S	692249	692232	497316
12T800	-	491588S -	298090S	-	-	398188	493765	498260	490566	397974S	272653S	272199S	692249	692232	497316
12U800	-	497725S 273185S	298090S	-	-	398188	-	498260	499424	397974S	272653S	272199S	692249	692232	497316
12V800	-	497725S 273185S	298090S	-	-	398188	-	498260	499424	397974S	272653S	272199S	692249	692232	497316
12W800	-	497725S 273185S	298090S	-	-	398188	-	498260	499424	397974S	272653S	272199S	692249	692232	497316
12X800	-	491588S 493537S	298090S	-	-	398188	-	498260	499424	397974S	272653S	272199S	692249	692232	497316
12Z600	-	491588S 493537S	-	-	-	398188	-	692703	499424	692046	692667	692668	695166	692232	694090
12Z800	-	491588S 493537S	-	-	-	398188	-	498260	499424	397974S	272653S	272199S	692249	692232	497316
120H00	-	491588S 493537S	298090S	-	-	398188	-	498260	499424	397974S	272653S	272199S	692249	692232	497316
120400	-	491588S 273356S	298090S	-	-	398188	-	695157	690124	694261	272948S	962555	695166	692549	695155
120600	-	491588S 493537S	298090S	-	-	398188	-	695157	499424	397974S	692667	692668	695166	692232	694090
121H00	-	491588S 493537S	-	-	-	398188	-	498260	499424	397974S	272653S	272199S	692249	692232	-

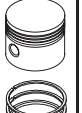















GENUINE PARTS QUICK REFERENCE 13-17

GAS-KETS	IGNITION				MUFFLER	OIL SEALS	PISTON RINGS & PISTON ASSY.			REWIND STARTER					VALVES
															
Valve Cover	Armature	Breaker Assy.	Condenser	Fly-wheel Key	Muffler Assy.	Oil Seals	Ring Set	Piston Assy.	Clutch	Grip	Pulley	Rope	Spring	Valves	
272481S	802574	-	-	222698S	496106S	299819S Mag 399781S PTO	499425 499426 499427 499428	Std. .010 .020 .030	499433 499434 499435 499436	-	281434S	498144	280399S	498144	262651S EX 262652 S IN
272481S	802574	-	-	222698S	496106S	299819S Mag 399781S PTO	499425 499426 499427 499428	Std. .010 .020 .030	499429 499430 499431 499432	-	281434S	498144	280399S	498144	262651S EX 262652 S IN
272481S	802574	-	-	222698S	496106S	299819S Mag 399781S PTO	Note 2		-	281434S	493824	280399S Note C	491889	262651S EX 262652 S IN	
272481S	802574	-	-	222698S	496106S	299819S Mag 399781S PTO	Note 2		-	281434S 393152	498144 493824	280399S Note C	498144 491889	262651S EX 262652 S IN	
272481S	802574	-	-	222698S	496106S	299819S Mag 399781S PTO	499425 499426 499427 499428	Std. .010 .020 .030	499429 499430 499431 499432	-	281434S	498144	692259	498144	262651S EX 262652 S IN
272481S	802574	-	-	222698S	494343S	299819S Mag 399781S PTO	499425 499426 499427 499428	Std. .010 .020 .030	499429 499430 499431 499432	-	281434S	498144	692259	498144	262651S EX 262652 S IN
272481S	802574	-	-	222698S	692038	299819S Mag 399781S PTO	499425 499426 499427 499428	Std. .010 .020 .030	499433 499434 499435 499436	-	281434S	498144	280399S	498144	262651S EX 262652 S IN
272481S	802574	-	-	222698S	694048	299819S Mag 399781S PTO	499425 499426 499427 499428	Std. .010 .020 .030	499429 499430 499431 499432	-	281434S	498144	692259	498144	262651S EX 262652 S IN
691890	802574	-	-	222698S	696526	299819S Mag 399781S PTO	499631 692785 692786 692787	Std. .010 .020 .030	690021 694167 694168 694169	-	281434S	498144	692259	498144	499642 EX 499641 IN
272481S	802574	-	-	222698S	692038	299819S Mag 399781S PTO	499425 499426 499427 499428	Std. .010 .020 .030	499429 499430 499431 499432	-	281434S	498144	692259	498144	262651S EX 262652 S IN
272481S	802574	-	-	222698S	496106S	299819S Mag 399781S PTO	499425 499426 499427 499428	Std. .010 .020 .030	499429 499430 499431 499432	-	281434S	498144	692259	498144	262651S EX 262652 S IN
691890	802574	-	-	222698S	693593	299819S Mag 691952 PTO	499631 692785 692786 692787	Std. .010 .020 .030	690021 694167 694168 694169	-	715257 693389	498144	693389	498144	499642 EX 499641 IN
272481S	802574	-	-	222698S	693982 694248	299819S Mag 399781S PTO	499631 692785 692786 692787	Std. .010 .020 .030	690021 694167 694168 694169	-	281434S	498144	692259	498144	499642 EX 499641 IN
272481S	802574	-	-	-	496106S	299819S Mag 399781S PTO	499425 499426 499427 499428	Std. .010 .020 .030	499429 499430 499431 499432	-	281434S	498144	692259	498144	262651S EX 262652 S IN











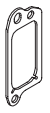
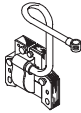

GENUINE DEALERS USE GENUINE PARTS

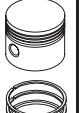

13-18 GENUINE PARTS QUICK REFERENCE

 Engine Model Series	AIR FILTER		FUEL FILTER/OIL FILTER		CARBURETOR				CONN. ROD ASSY.	FUEL TANK CAP	GASKETS				
	Foam	 Cartridge  Pre-Cleaner	 Fuel Filter	 Oil Filter	 Dia-phragm	 Float Valve	 Needle Valve	 Over-haul/Repair Kit	 Rod Assy.	 Tank Cap	 Air Cleaner	 Carb. to Cylinder	 Cylinder Head	 Oil Sump/Cover	 Set
121400	-	491588S 690610 493537S 273356S	298090S 694485	-	-	398188	-	690032 695157 Note 2	690124	493988S 694261 Note 2	272948S	692555 2 Required	692554 695166 Note 2	692549	690031 695155 Note 2
121600	-	690610 273356S	298090S	-	-	398188	-	692703	499424	692046	691894	692668	691889 695166 Note 2	692232	692702
121700	-	491588S -	-	-	-	398188	Note IA	Note 2	490566	Note 1	272296	272199S	272200S	692232	496117
121800	-	491588S -	-	-	-	398188	493765	498260	490566	397974S	272296	272199S	272200S	692232	496117
122H00	-	491588S 493537S	-	-	-	398188	-	498260	499424	397974S	272653S	272199S	692249	692232	497316
122K00	-	491588S 493537S	-	-	-	398188	-	498260	499424	397974S	272653S	272199S	692249	692232	-
122600	-	690610 273356S	298090S	692513	-	398188	-	692703	499424	692046	691894	692668	691889	692232	692702
122700	-	491588S -	-	-	-	398188	493765	493762	490566	397974S	272296 272653	272199S	272200S	692232	496117
123H00	-	491588S 493537S	-	-	-	398188	-	498260	4999424	397974S	272653S	272199S	692249	692232	497316
123K00	-	491588S -	-	-	-	398188	-	498260	4999424	397974S	272653S	272199S	692249	692232	-
123400	-	690610 273356S	694485	-	-	398188	-	695157	690124	694261	693458	692555	695166	692549	695155
123600	-	690610 273356S	-	692513	-	398188	-	692703	499424	Note 4	691894	692668	691889	692232	692702
123700	-	491588S -	-	-	-	398188	493765	493765	490566	397974S	272296 272653	272199S	272200S	692232	496117
123800	-	491588S -	-	-	-	398188	493765	493762	490566	397974S	272296 272653	272199S	272200S	692232	496117
124H00	-	491588S 493537S	-	-	-	398188	-	498260	499424	397974S	272653S	272199S	692249	692232	497316















GENUINE PARTS QUICK REFERENCE 13-19

GAS-KETS	IGNITION				MUFFLER	OIL SEALS	PISTON RINGS & PISTON ASSY.			REWIND STARTER					VALVES	
																
Valve Cover	Arma- ture	Breaker Assy.	Con- denser	Fly- wheel Key	Muffler Assy.	Oil Seals	Ring Set	Piston Assy.	Clutch	Grip	Pulley	Rope	Spring	Valves		
691890	692605	-	-	222698S	Note 2	299819S Mag 692550 PTO	499631 692785 692786 692787	Std. .010 .020 .030	499627 692788 692789 692790	-	Note 1	498144	280399S Cut to Length	Note 3	499642 499641	EX IN
272481S	802574	-	-	222698S	Note 2	299819S Mag 399781S PTO	499631 692785 692786 692787	Std. .010 .020 .030	499627 692788 692789 692790	-	281434S	498144	280399S Cut to Length	Note 3	499642 499641	EX IN
272481S	802574	-	-	222698S	496106S 494343S	299819S Mag 399781S PTO	493261 493388 493389 493390	Std. .010 .020 .030	493262 493385 493386 493387	-	393152	493824	280399S Note C	491889	262651S 262652 S	EX IN
272481S	802574	-	-	222698S	496106S 494343S	299819S Mag 399781S PTO	493261 493388 493389 493390	Std. .010 .020 .030	493262 493385 493386 493387	-	393152	493824	280399S Note C	491889	262651S 262652 S	EX IN
272481S	802574	-	-	222698S	494343S	299819S Mag 399781S PTO	499425 499426 499427 499428	Std. .010 .020 .030	499429 499430 499431 499432	-	281434S	198144	692259	498144	262651S 262652 S	EX IN
696125	802574	-	-	222698S	494343S	299819S Mag 399781S PTO	499425 499426 499427 499428	Std. .010 .020 .030	697339 697340 697341 697342	-	281434S	498144	692259	498144	262651S 262652 S	EX IN
272481S	802574	-	-	222698S	Note 2	299819S Mag 399781S PTO	499631 692785 692786 692787	Std. .010 .020 .030	499627 692788 692789 692790	-	281434S	498144	280399S Cut to Length	498144 Note 3	499642 499641	EX IN
272481S	802574	-	-	222698S	496106S 494343S	299819S Mag 399781S PTO	493261 493388 493389 493390	Std. .010 .020 .030	493262 493385 493386 493387	-	393152	493824	280399S Note C	491889	262651S 262652S	EX IN
272481S	802574	-	-	222698S	496106S	299819S Mag 399781S PTO	499425 499426 499427 499428	Std. .010 .020 .030	499433 499434 499435 499436	-	281434S	498144	692259	498144	262651S 262652S	EX IN
696125	802574	-	-	222698S	692038	299819S Mag 399781S PTO	499425 499426 499427 499428	Std. .010 .020 .030	697339 697340 697341 697342	-	-	-	692259	-	262651S 262652S	EX IN
691890	802574	-	-	222698S	693593	299819S Mag 692550 PTO 694171 PTO	499631 692785 692786 692787	Std. .010 .020 .030	499627 692788 692789 692790	-	715257	498144	693389	498144	499642 499641	EX IN
272481S	802574	-	-	222698S	692275	299819S Mag 399781S PTO	499425 499426 499427 499428	Std. .010 .020 .030	499429 499430 499431 499432	-	494212	498144	280399S Cut to Length	Note 3	499642 499641	EX IN
272481S	802574	-	-	222698S	490547	299819S Mag 399781S PTO	493261 493388 493389 493390	Std. .010 .020 .030	493262 493385 493386 493387	-	393152	493824	280399S Note C	491889	262651S 262652S	EX IN
272481S	802574	-	-	222698S	490547	299819S Mag 399781S PTO	493261 493388 493389 493390	Std. .010 .020 .030	493262 493385 493386 493387	-	393152	493824	280399S Note C	491889	262651S 262652S	EX IN
272481S	802574	-	-	222698S	496106S	299819S Mag 399781S PTO	499425 499426 499427 499428	Std. .010 .020 .030	499433 499434 499435 499436	-	281434S	498144	692259	498144	262651S 262652S	EX IN









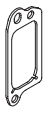
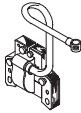

GENUINE DEALERS USE GENUINE PARTS

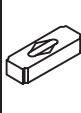

13-20 GENUINE PARTS QUICK REFERENCE

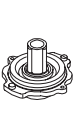
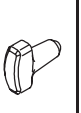
 Engine Model Series	AIR FILTER		FUEL FILTER/OIL FILTER		CARBURETOR				CONN. ROD ASSY.	FUEL TANK CAP	GASKETS				
	Foam	 Cartridge Pre-Cleaner	 Fuel Filter	 Oil Filter	 Dia- phragm	 Float Valve	 Needle Valve	 Over- haul/ Repair Kit	 Rod Assy.	 Tank Cap	 Air Cleaner	 Carb. to Cylin- der	 Cylin- der Head	 Oil Sump/ Cover	 Set
124K00	-	491588S -	-	-	-	398188	-	498260	499424	397974S	272653S	272199S	692249	692232	-
124400	696263	- -	694485	-	-	398188	-	695157	690124	694261	272948S	691885	695166	692549	695155
124600	-	491588S 493537S	-	692513	-	398188	-	692703	499424	692046	692667	692668	695166	692232	694090
124700	-	491588S 493537S	-	-	-	398188	493765	493762	490566	397974S	272296 272653	272199S	272200S	692232	496117
124800	-	491588S -	-	-	-	398188	493765	498260	490566	397974S	272296 272653	272199S	272200S	692232	496117
125H00	-	491588S 493537S	-	-	-	398188	-	498260	499424	397974S	272653S	272199S	692249	692232	497316
125600	-	491588S 493537S	-	-	-	398188	-	692703	499424	692046	692667	692668	695166	692232	694090
125700	-	491588S 493537S	-	-	-	398188	493765	498260	490566	397974S	272296	272199S	272200S	692232	496117
126400	-	491588S 273356S	694485	-	-	398188	-	695157	690124	694261	272948S	692555	695166	692549	695155
126600	-	690610 273356S	-	-	-	398188	-	692703	699424	692046	692667	692668	695166	692232	694090
126700	-	491588S 493537S	298090S	-	-	398188	493765	498260	490566	397974S	272296 272653	272199S	272200S	692232	496117
126800	-	491588S 493537S	298090S	-	-	398188	493765	498260	490566	397974S	272296 272653	272199S	272200S	692232	496117
127400	-	491588S 493537S	-	-	-	398188	-	695157	690124	694261	272948S	692555	695166	692549	695155
127700	-	491588S -	298090S	-	-	398188	493765	498260	490566	397974S	272653	272199S	272200S	692232	496117
127800	-	491588S -	298090S	-	-	398188	493765	498260	490566	397974S	272653	272199S	272200S	692232	496117

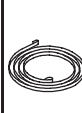















GENUINE PARTS QUICK REFERENCE 13-21

GAS-KETS	IGNITION				MUFFLER	OIL SEALS	PISTON RINGS & PISTON ASSY.			REWIND STARTER					VALVES
															
Valve Cover	Armature	Breaker Assy.	Condenser	Fly-wheel Key	Muffler Assy.	Oil Seals	Ring Set	Piston Assy.	Clutch	Grip	Pulley	Rope	Spring	Valves	
696125	802574	-	-	222698S	692038	299819S Mag 399781S PTO	499425 499426 499427 499428	Std. .010 .020 .030	697339 697340 697341 697342	-	-	-	692259	-	262651S EX 262652S IN
691890	802574	-	-	222698S	693593	299819S Mag 399781S PTO	499631 692785 692786 692787	Std. .010 .020 .030	499627 692788 692789 692790	-	715257	498144	693389	498144	499642 EX 499641 IN
691890	802574	-	-	222698S	694248	299819S Mag 399781S PTO	499631 692785 692786 692787	Std. .010 .020 .030	499627 692788 692789 692790	-	281434	498144	692259	498144	499642 EX 499641 IN
272481S	802574	-	-	222698S	496106S 494343S	299819S Mag 399781S PTO	493261 493388 493389 493390	Std. .010 .020 .030	493262 493385 493386 493387	-	393152	493824	280399S Note C	491889	262651S EX 262652S IN
272481S	802574	-	-	222698S	496106S 494343S	299819S Mag 399781S PTO	493261 493388 493389 493390	Std. .010 .020 .030	493262 493385 493386 493387	-	393152	493824	280399S Note C	491889	262651S EX 262652S IN
272481S	802574	-	-	222698S	692038	299819S Mag 399781S PTO	499425 499426 499427 499428	Std. .010 .020 .030	499433 499434 499435 499436	-	281434	498144	692259	498144	262651S EX 262652S IN
272481S	802574	-	-	222698S	694248	299819S Mag 399781S PTO	499631 692785 692786 692787	Std. .010 .020 .030	499627 692788 692789 692790	-	281434	498144	692259	498144	499642 EX 499641 IN
272481S	802574	-	-	222698S	496106S	299819S Mag 399781S PTO	493261 493388 493389 493390	Std. .010 .020 .030	493262 493385 493386 493387	-	393152	493824	280399S Note C	491889	262651S EX 262652S IN
691890	802574	-	-	222698S	693593	299819S Mag 691952 PTO	499631 692785 692786 692787	Std. .010 .020 .030	690021 694167 694168 694169	-	693389	498144	693389	498144	499642 EX 499641 IN
691890	802574	-	-	222698S	694248	299819S Mag 399781S PTO	499631 692785 692786 692787	Std. .010 .020 .030	690021 694167 694168 694169	-	281434S	498144	692259	498144	499642 EX 499641 IN
272481S	802574	-	-	222698S	496106S	299819S Mag 399781S PTO	493261 493388 493389 493390	Std. .010 .020 .030	494058 494059 494060 494061	-	393152	493824	280399S Note C	491889	262651S EX 262652S IN
272481S	802574	-	-	222698S	496106S	299819S Mag 399781S PTO	493261 493388 493389 493390	Std. .010 .020 .030	494058 494059 494060 494061	-	393152	493824	280399S Note C	491889	262651S EX 262652S IN
691890	802574	-	-	222698S	693593	299819S Mag 692550 PTO	499631 692785 692786 692787	Std. .010 .020 .030	499627 692788 692789 692790	-	715257	498144	693389	498144	499642 EX 499641 IN
272481S	802574	-	-	222698S	496106S	299819S Mag 399781S PTO	493261 493388 493389 493390	Std. .010 .020 .030	493262 493385 493386 493387	-	393152	493824	280399S Note C	491889	262651S EX 262652S IN
272481S	802574	-	-	222698S	496106S	299819S Mag 399781S PTO	493261 493388 493389 493390	Std. .010 .020 .030	493262 493385 493386 493387	-	393152	493824	280399S Note C	491889	262651S EX 262652S IN











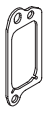
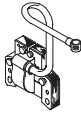

GENUINE DEALERS USE GENUINE PARTS

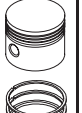

13-22 GENUINE PARTS QUICK REFERENCE

 Engine Model Series	AIR FILTER		FUEL FILTER/OIL FILTER		CARBURETOR				CONN. ROD ASSY.	FUEL TANK CAP	GASKETS				
	Foam	 Cartridge  Pre-Cleaner	 Fuel Filter	 Oil Filter	 Dia- phragm	 Float Valve	 Needle Valve	 Over- haul/ Repair Kit	 Rod Assy.	 Tank Cap	 Air Cleaner	 Carb. to Cylin- der	 Cylin- der Head	 Oil Sump/ Cover	 Set
128400	-	697029 273356S	-	-	-	398188	-	695157	690124	694261	696979	692555	695166	692549	-
128700	-	491588S -	298090S	-	-	398188	493765	498260	490566	397974S	272653S	272199S	272200S	692232	496117
128800	-	491588S -	298090S	-	-	398188	493765	498260	490566	397974S	272653S	272199S	272200S	692232	496117
129700	-	491588S 493537S	298090S	-	-	398188	493765	498260	490566	397974S	272653S	272199S	272200S	692232	496117
129800	-	491588S 493537S	298090S	-	-	398188	493765	498260	490566	397974S	272653S	272199S	272200S	692232	496117
130200 Type Nos. Below 2300 5100-5199	27987S	392308S 396424S 271466	-	-	270026	-	299060	495606	299430	Note 1 Check Type #	27660 Note A 271077 Note B 271139S Note B	27355S (2 used)	272157S	692213 .015 270125 .005 270126 .009	495603
130200 Type Nos. 2900-4100 5200-5600	-	491588S - 491435S	-	-	270026	-	691777	495606	299430	494559	271935S	273113S (2 used)	272157S	692213 .015 270125 .005 270126 .009	495603
130400	-	396424S 271466	-	-	-	293478	399619	398993	299430	69221	271139S	27355S	272157S	692213 .015 270125 .005 270126 .009	495603
130700	-	397795S 399039	-	-	-	398188	490890 (Idle) 493765 (Main)	494349 Note V	299429	69221	272296	270070	272157S	270069 .015 270122 .005 270123 .009	496659
130900	270447	392308S 396424S 271466	-	-	270026	-	299060	494625	299429	394818S	27660 Note A 271139S Note B	270070	272157S	270069 .015 270122 .005 270123 .009	496659
131200	27987S	392308S 396424S 271466	-	-	270026	-	299060	495606	299430	394818S	27660 Note A 271139S Note B 271755 Note B	27355S (2 used)	272157S	692213 .015 270125 .005 270126 .009	495603
131400	-	392308S 396424S 271466	-	-	-	293478	393960	394010	299430	392305S 69221	271139S	27355S	272157S	692213 .015 270125 .005 270126 .009	495603
131700	-	397795S 399039	-	-	-	398188	490890 (Idle) 493765 (Main)	494349 Note V	299429	69221	272296	270070	272157S	270069 .015 270122 .005 270123 .009	496659

















GENUINE PARTS QUICK REFERENCE 13-23

GAS-KETS	IGNITION				MUFFLER	OIL SEALS	PISTON RINGS & PISTON ASSY.			REWIND STARTER					VALVES
															
Valve Cover	Arma- ture	Breaker Assy.	Con- denser	Fly- wheel Key	Muffler Assy.	Oil Seals	Ring Set	Piston Assy.	Clutch	Grip	Pulley	Rope	Spring	Valves	
-	695711	-	-	222698S	694429	299819S Mag 692550 PTO	499631 692785 692786 692787	Std. .010 .020 .030	499627 692788 692789 692790	-	-	-	693389	-	499642 EX 499641 IN
272481S	802574	-	-	222698S	496106S	299819S Mag 399781S PTO	493261 493388 493389 493390	Std. .010 .020 .030	493262 493385 493386 493387	-	393152	493824	280399S Note C	491889	262651S EX 262652S IN
272481S	802574	-	-	222698S	496106S	299819S Mag 399781S PTO	493261 493388 493389 493390	Std. .010 .020 .030	493262 493385 493386 493387	-	393152	493824	280399S Note C	491889	262651S EX 262652S IN
272481S	802574	-	-	222698S	496106S	299819S Mag 399781S PTO	493261 493388 493389 493390	Std. .010 .020 .030	494058 494059 494060 494061	-	393152	493824	280399S Note C	491889	262651S EX 262652S IN
272481S	802574	-	-	222698S	496106S	299819S Mag 399781S PTO	493261 493388 493389 493390	Std. .010 .020 .030	494058 494059 494060 494061	-	393152	493824	280399S Note C	491889	262651S EX 262652S IN
27549S	697037 Note D 397358 Note E	294628	See Breaker Assy.	222698S	Note 1	299819S Mag 294606S PTO	298982 298983 298984 298985 299742	Std. .010 .020 .030 Chrome	298904 298905 298906 298907 -	399671	393152 490652	295871 Note U	692188 Note C	490179	211119S EX 261044 S IN
27549S	397358	-	-	222698S	Note 1	299819S Mag 294606S PTO	298982 298983 298984 298985 299742	Std. .010 .020 .030 Chrome	298904 298905 298906 298907 -	399671	490652	295871 Note U	692188 Note C	490179	211119S EX 261044 S IN
27549S	397358	-	-	222698S	494585 691969	299819S Mag 393812 PTO	298982 298983 298984 298985 299742	Std. .010 .020 .030 Chrome	298904 298905 298906 298907 -	399671	490652	295871 Note U	692188 Note C	490179	211119S EX 261044S IN
27549S	397358	-	-	222698S	390918S 496892 494585 691969	299819S Mag 391485 PTO	298982 298983 298984 298985 299742	Std. .010 .020 .030 Chrome	298904 298905 298906 298907 -	399671	490652	295871 Note U	692188 Note C	490179	211119S EX 261044S IN
27549S	697037 Note D 397358 Note E	294628	See Breaker Assy.	222698S	494585 390918S 692304 393010S	299819S Mag 391485 PTO	298982 298983 298984 298985 299742	Std. .010 .020 .030 Chrome	298904 298905 298906 298907 -	399671	490652	295871 Note U	692188 Note C	490179	211119S EX 261044S IN
27549S	697037 Note D 397358 Note E	294628	See Breaker Assy.	222698S	692304 393010S 494585 691969	299819S Mag 294606S PTO	399067 Note W 399014 399015 399016	Std. .010 .020 .030	393819 393820 393821 393822	399671	490652	295871 Note U	692188 Note C	490179	494191 EX 261044S IN
27549S	697037 Note D 397358 Note E	294628	See Breaker Assy.	222698S	692304 393010S 496892 494585	299819S Mag 393812 PTO	399067 Note W 399014 399015 399016	Std. .010 .020 .030	393819 393820 393821 393822	399671	490652	295871 Note U	692188 Note C	490179	494191 EX 261044S IN
27549S	397358	-	-	222698S	390918S 496892 494585 691969	393812 Mag 391485 PTO	399067 Note W 399014 399015 399016	Std. .010 .020 .030	393819 393820 393821 393822	399671	490652	295871 Note U	692188 Note C	490179	211119S EX 261044S IN



USING GENUINE PARTS COMPLEMENTS YOUR QUALITY LABOR & SKILLS



13-24 GENUINE PARTS QUICK REFERENCE

 Engine Model Series	AIR FILTER		FUEL FILTER/OIL FILTER		CARBURETOR				CONN. ROD ASSY.	FUEL TANK CAP	GASKETS				
	Foam	 Cartridge  Pre-Cleaner	 Fuel Filter	 Oil Filter	 Dia- phragm	 Float Valve	 Needle Valve	 Over- haul/ Repair Kit	 Rod Assy.	 Tank Cap	 Air Cleaner	 Carb. to Cylin- der	 Cylin- der Head	 Oil Sump/ Cover	 Set
131900	-	392308S 396424S 271466	-	-	270026	-	299060	494625	299429	394818S	271139S	270070	272157S	270069 .015 270122 .005 270123 .009	496659
132200 Type Nos. 0100-0300 2000-2200	-	396424S 271466	-	-	270026	-	299060	495606	299430	394818S	271139S	27355S (2 used)	272157S	692213 .015 270125 .005 270126 .009	495603
132200 Type Nos. 0301-0499 2200-2299 Above 4000	-	491588S 491435S	-	-	270026	-	691777	495606	299430	494559	271935S	273113S (2 used)	272157S	692213 .015 270125 .005 270126 .009	495603
132400	-	396424S 271466	-	-	-	293478	399619 Note Y	398993 Note Z	299430	392305S	271139S	27355S	272157S	692213 .015 270125 .005 270126 .009	495603
132900	-	396424S 271466	-	-	270026	-	299060	494625	299429	394818S	271139S	270070	272157S	270069 .015 270122 .005 270123 .009	496659
133200	-	491588S 491435S	-	-	272538S	-	691777	495606	299430	494559	271935S	273113S (2 used)	272157S	692213 .015 270125 .005 270126 .009	495603
133400	-	494511S 492889	298090S	-	-	398188	493765	498260	299430	493988S	272948S	273113S	272157S	692213 .015 270125 .005 270126 .009	495661
133700	-	491588S 493537S	-	-	-	398188	493765	498260	299430	397974S	272653S	270070	272157S	270069 .015 270122 .005 270123 .009	496659
134400	-	494511S 492889	-	-	-	398188	-	Note 1	299430	493988S	272948S	Note 1	272157S	692213 .015 270125 .005 270126 .009	495661
135200	-	396424S 491588S 271466 493537S	-	-	272538S	-	299060 691777	495606	299430	494559	271935S	273113S (2 used)	272157S	692213 .015 270125 .005 270126 .009	495603
135400	-	494511S 492889	298090S	-	-	398188	-	498260	299430	692662 692665	272948S	273113S	272157S	270125 .005 270126 .009 692213 .015	495661
135700	-	491588S 493537S	-	-	-	398188	493765	498260	299430	397974S	272653S	270070	272157S	270069 .015 270122 .005 270123 .009	496659
136200	-	491588S 491435S	-	-	272538S	-	691777	495606	299430	498156	271935S	273113S	272157S	692213 .015 270125 .005 270126 .009	495603

















GENUINE PARTS QUICK REFERENCE 13-25

GAS-KETS	IGNITION			MUFF-LER	OIL SEALS	PISTON RINGS & PISTON ASSY.			REWIND STARTER					VALVES	
															
Valve Cover	Arma-ture	Breaker Assy.	Con-denser	Fly-wheel Key	Muffler Assy.	Oil Seals	Ring Set	Piston Assy.	Clutch	Grip	Pulley	Rope	Spring	Valves	
27549S	697037 Note D 397358 Note E	294628	See Breaker Assy.	222698S	390918S 393010S 494585	299819S Mag 391485 PTO	399067 Note W 399014 399015 399016	Std. .010 .020 .030	393819 393820 393821 393822	399671	490652	295871 Note U	692188 Note C	490179	691827 EX Note X 261044S IN
27549S	397358	-	-	222698S	390918S 692304 496892 494585 691969	299819S Mag 393812 PTO	399067 Note W 399014 399015 399016	Std. .010 .020 .030	393819 393820 393821 393822	399671	490652	295871 Note U	692188 Note C	490179	494191 EX 261044S IN
27549S	397358	-	-	222698S	390918S 692304 393010S 496892 494585 691969	299819S Mag 393812 PTO	399067 Note W 399014 399015 399016	Std. .010 .020 .030	393819 393820 393821 393822	399671	490652	295871 Note U	692188 Note C	490179	691827 EX Note X 261044S IN
27549S	397358	-	-	222698S	692304 393010S 496892 494585 691969	299819S Mag 393812 PTO	399067 Note W 399014 399015 399016	Std. .010 .020 .030	393819 393820 393821 393822	399671	490652	295871 Note U	692188 Note C	490179	691827 EX Note X 261044S IN
27549S	697037 Note D 397358 Note E	294628	See Breaker Assy.	222698S	390918S 393010S 494585 691969	299819S Mag 391485 PTO	399067 Note W 399014 399015 399016	Std. .010 .020 .030	393819 393820 393821 393822	399671	490652	295871 Note U	692188 Note C	490179	691827 EX Note X 261044S IN
27549S	397358	-	-	222698S	390918S 494585 691969 496892	299819S Mag 393812 PTO	399067 399014 399015 399016	Std. .010 .020 .030	393819 393820 393821 393822	-	393152	493824	280406S Note C	491889	691827 EX 261044S IN
27549S	397358	-	-	222698S	692006	299819S Mag 393812 PTO	399067 399014 399015 399016	Std. .010 .020 .030	393819 393820 393821 393822	-	393152	493824	280406S Note C	491889	211119S EX 261044S IN
27549S	397358	-	-	222698S	390918S 494585	299819S Mag 391485 PTO	399067 399014 399015 399016	Std. .010 .020 .030	393819 393820 393821 393822	-	393152	493824	280399S Note C	491889	691827 EX 261044S IN
27549S	802574	-	-	222698S	692006	299819S Mag 294606S PTO	399067 399014 399015 399016	Std. .010 .020 .030	393819 393820 393821 393822	-	393152	498144	280399S Cut to Length	Note 3	211119S EX 261044S IN
27549S	397358	-	-	222698S	390918S 393010S 496892 494585 691969 496892	299819S Mag 391485 PTO	298982 298983 298984 298985 299742	Std. .010 .020 .030 Chrome	298904 298905 298906 298907	-	393152	493824	280399S Note C	491889	211119S EX 261044S IN
27549S	397358	-	-	222698S	692006	299819S Mag 495307S PTO	399067 399014 399015 399016	Std. .010 .020 .030	393819 393820 393821 393822	-	691915	498144	691921	498144	211119S EX 261044S IN
27549S	397358	-	-	222698S	494585	299819S Mag 391485 PTO	298982 298983 298984 298985 299742	Std. .010 .020 .030 Chrome	298904 298905 298906 298907	-	393152	493824	280399S Note C	491889	211119S EX 261044S IN
27549S	397358	-	-	222698S	494585 496892	294606S Mag 495307S PTO	298982 298983 298984 298985 299742	Std. .010 .020 .030 Chrome	298904 298905 298906 298907 -	-	393152	498144	280399S Note C	498144	211119S EX 261044S IN

GENUINE PARTS . . . YOUR GUARANTEE OF PRECISION FIT



13-26 GENUINE PARTS QUICK REFERENCE

















 Engine Model Series	AIR FILTER		FUEL FILTER/OIL FILTER		CARBURETOR				CONN. ROD ASSY.	FUEL TANK CAP	GASKETS				
	Foam	 Cartridge  Pre-Cleaner	 Fuel Filter	 Oil Filter	 Dia- phragm	 Float Valve	 Needle Valve	 Over- haul/ Repair Kit	 Rod Assy.	 Tank Cap	 Air Cleaner	 Carb. to Cylin- der	 Cylin- der Head	 Oil Sump/ Cover	 Set
137200	-	491588S 491435S	-	-	272538S	-	691777	495606	299430	494559	271935S	273113S	272157S	270125 .005 270126 .009 692213 .015	495603
138400	-	491588S 4S	298090S	-	-	710661	-	715484	715427	710490	710639	710060	710624	710628	715714
161400	-	491384 492889	-	-	-	492188	492277 (Idle)	492287	491908	491367S	-	273113S	272067	272068	491999
170400 Type Nos. 0500-1999	270093	390492 393957S 271794S	-	-	-	394681 Note AA	292681 (Idle) 99525S (Main)	394693	398577	392305S	27907	27828S	272163S	692221 .015 27876 .005 27877 .009	299577
170400 Type Nos. Above 2000	270093	390492 393957S 399968 271794S 271939	-	-	-	394681 Note AA	292681 (Idle) 99525S (Main)	398235 Note BB	398577	392305S	27907 271910	27828S	272163S	692221 .015 27876 .005 27877 .009	299577
170700	270528S	393406 -	-	-	-	394681 Note AA	292681 (Idle) 396568 (Main) Note CC	394698	295839	394818S 493988S	270539	692915 272554S	272163S	692221 .015 27876 .005 27877 .009	299577
171400	-	390492 393957S 399968 271794S 271939	-	-	-	394681 Note AA	292681 (Idle) 99525S (Main)	398235 Note BB	398577	392305S	27907 271910	27828S	272163S	692221 .015 27876 .005 27877 .009	299577
176400	-	691643 492889	-	-	-	691782	494383	497578	398577	493988S	692277	272707 691885	272163S	692221 .015 27876 .005 27877 .009	497070
184400	-	491588S 491435S	-	-	-	-	-	-	715771	-	692081	710235	710205	710216	715778
185400	-	491588S 710266 491435S 710268	298090S 691035	-	-	715155	715076 715293	715156	715106	710490	-	710235	710205	710216	715124
19B400	-	691643 -	-	-	-	691782	494383	497578	390401	-	692277	691885	272163S	692221 .015 27876 .005 27877 .009	497070
19C400	-	691643 492889	-	-	-	691782	-	497578	390401	493988S	692277	691886	272163S	692221 .015 27876 .005 27877 .009	497070
19E400	-	691643 -	394358S	-	-	691782	494383	497578	390401	-	692277	691885	272163S	692221 .015 27876 .005 27877 .009	497070

GENUINE PARTS QUICK REFERENCE 13-27











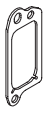
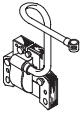

GAS-KETS	IGNITION				MUFFLER	OIL SEALS	PISTON RINGS & PISTON ASSY.			REWIND STARTER					VALVES
Valve Cover	Armature	Breaker Assy.	Condenser	Fly-wheel Key	Muffler Assy.	Oil Seals	Ring Set	Piston Assy.		Clutch	Grip	Pulley	Rope	Spring	Valves
27549S	397358	-	-	222698S	494585	299819S Mag 294606S PTO	498680 499681 498682 498683	Std. .010 .020 .030	498668 498669 498670 498671	-	691915	498144	691921	498144	21119S EX 261044S IN
-	715464	-	-	710037	715508	710000 Mag 710215 PTO	715452 715453 715454 -	Std. .010 .020 .030	715594 715596 715595 -	-	490652	710274	66574	710270	715445 EX 715446 IN
272063 Rocker Cover	492341	-	-	222698S	491512 493584	491500 Mag 491500 PTO	491905 492712 492713 -	Std. .010 .020 .030	491903 - - 492711	-	490652	281235	692188 Note C	492194	491910 EX 491911 IN
27803S	298968	294628	See Breaker Assy.	222698S	294599S 692304 393010S	294606S Mag 391086S PTO	499921 690018 690019 690020 299743	Std. .010 .020 .030 Chrome	499907 499908 499909 499910 -	399671	490652	295871 Note U	692188 Note C	490179	691794 EX 261055S IN
27803S	298968	294628	See Breaker Assy.	222698S	692304 393010S 494221 494222	294606S Mag 391086S PTO	499921 690018 690019 690020 299743	Std. .010 .020 .030 Chrome	499907 499908 499909 499910 -	399671	490652	295871 Note U	692188 Note C	490179	691794 EX 261055S IN
27803S	298968 Note D 398811 Note E	294628	See Breaker Assy.	222698S	692304 393010S 691971	294606S Mag 391086S PTO	499921 690018 690019 690020 299743	Std. .010 .020 .030 Chrome	499907 499908 499909 499910 -	399671	490652	295871 Note U	692188 Note C	490179	691794 EX 261055S IN
27803S	398811	-	-	222698S	692304 393010S 494222 494221	294606S Mag 391086S PTO	690014 690015 690016 690017 299743	Std. .010 .020 .030 Chrome	499960 499961 499962 499963 -	399671	490652	295871 Note U	692188 Note C	490179	691794 EX 261055S IN
27803S	398811	-	-	222698S	692025 497141	391086S Mag 391086S PTO	690014 690015 690016 690017 299743	Std. .010 .020 .030 Chrome	499960 499961 499962 499963 -	399671	490652	295871 Note U	692188 Note C	490179	691794 EX 261055S IN
710206	715192	-	-	710037	715523	710000 Mag 710215 PTO	715111 715112 715113 -	Std. .010 .020 .030	715645 715649 715651 -	-	-	-	-	-	715085 EX 715754 IN
710206 Rocker Cover	715118	-	-	710037	715523	710000 Mag 710215 PTO	715111 715112 715113 -	Std. .010 .020 .030	715645 715649 715651 -	-	490652	494956	692188 Note C	492194	715085 EX 715754 IN
27803S	492341	-	-	222698S	-	391086S Mag 391086S PTO	690014 690015 690016 690017 299743	Std. .010 .020 .030 Chrome	499960 499961 499962 499963 -	399671	490652	295871 Note U	692188 Note C	490179	691794 EX 261055S IN
27803S	492341	-	-	222698S	692025	391086S Mag 391086S PTO	690014 690015 690016 690017	Std. .010 .020 .030	499960 499961 499962 499963	399671	490652	295871	692188	490179	691811 EX 261055S IN
27803S	492341	-	-	222698S	-	391086S Mag 391086S PTO	690014 690015 690016 690017 299743	Std. .010 .020 .030 Chrome	499960 499961 499962 499963 -	399671	490652	295871 Note U	692188 Note C	490179	691794 EX 261055S IN

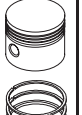

13-28 GENUINE PARTS QUICK REFERENCE

 Engine Model Series	AIR FILTER		FUEL FILTER/OIL FILTER		CARBURETOR				CONN. ROD ASSY.	FUEL TANK CAP	GASKETS				
	Foam	 Cartridge  Pre-Cleaner	 Fuel Filter	 Oil Filter	 Dia-phragm	 Float Valve	 Needle Valve	 Over-haul/Repair Kit	 Rod Assy.	 Tank Cap	 Air Cleaner	 Carb. to Cylinder	 Cylin-der Head	 Oil Sump/ Cover	 Set
19F400	-	691643 492889	394358S 691035	-	-	691782	494383	See Parts List	390401	493988S	692277	691885	272163S	692221 .015 27876 .005 27877 .009	497070
19G400	-	691643 -	298090S 394358S	-	-	691782	494383	See Parts List	390401	493988S	692277	691885	272163S	692221 .015 27876 .005 27877 .009	497070
19K400	-	691643 492889	298090S	-	-	691782	-	497578	390401	692662 692665	692277	691885	272163S	27876	497070
190400 Type Nos. 0010-2100	270093	390492 393957S 271794S	-	-	-	394681 Note AA	292681 (Idle) 99525S (Main)	394693	390401	392305S	27907	27828S	272163S	692221 .015 27876 .005 27877 .009	299577
190400 Type Nos. Above 2500	270093	390492 393957S 399968 271794S 271939	-	-	-	394681 Note AA	292681 (Idle) 99525S (Main)	398235 Note BB	390401	392305S	27907 271910	27828S	272163S	692221 .015 27876 .005 27877 .009	299577
190700	270528S	393406 -	-	-	-	394681 Note AA	292681 (Idle) 396568 (Main) Note CC	394698	390402	394818S 493988S	270539	692915	272163S	692221 .015 27876 .005 27877 .009	299577
191700	270528S	393406 -	-	-	-	394681 Note AA	292681 (Idle) 396568 (Main) Note CC	394698	390402	394818S 493988S	270539	692915	272163S	692221 .015 27876 .005 27877 .009	299577
192400	-	691643 492889	298090S 394358S	-	-	691782	494383	See Illus. Parts List	390401	493988S	692277	691885	272163S	692221 .015 27876 .005 27877 .009	497070
192700	270528S	393406 -	-	-	-	394681 Note AA	292681 (Idle) 396568 (Main) Note CC	394698	390402	394818S 493988S	270539	272554S	272163S	692221 .015 27876 .005 27877 .009	299577
193700	270528S	393406 -	-	-	-	394681 Note AA	292681 (Idle) 396568 (Main) Note CC	394698	390402	493988S	270539	272554S	272163S	692221 .015 27876 .005 27877 .009	299577
194400	-	393957S 271794S	-	-	-	394681 Note AA	292681 (Idle) 99525S (Main)	398235	390401	392305S	-	27828S	272163S	692221 .015 27876 .005 27877 .009	299577
194700	272922	-	298090S	-	-	494788	494383 (Idle)	497535	390402	493988S	691917	272554S	272163S	692221 .015 27876 .005 27877 .009	299577
195400 Type Nos. 0100-0400 2000-2099	-	393957S 399968 271794S 271939	-	-	-	394681 Note AA	292681 (Idle) 99525S (Main)	398235 Note BB	390401	392305S	271910	27828S	272163S	692221 .015 27876 .005 27877 .009	299577

















GENUINE PARTS QUICK REFERENCE 13-29

GAS-KETS	IGNITION			MUFFLER	OIL SEALS	PISTON RINGS & PISTON ASSY.			REWIND STARTER					VALVES	
															
Valve Cover	Arma- ture	Breaker Assy.	Con- denser	Fly- wheel Key	Muffler Assy.	Oil Seals	Ring Set	Piston Assy.	Clutch	Grip	Pulley	Rope	Spring	Valves	
27803S	492341	-	-	222698S	692025 497141	391086S Mag 391086S PTO	690014 690015 690016 690017 299743	Std. .010 .020 .030 Chrome	499960 499961 499962 499963 -	399671	490652	295871 Note U	692188 Note C	490179	691794 EX 261055S IN
27803S	492341	-	-	222698S	691951 692025	391086S Mag 391086S PTO	690014 690015 690016 690017 299743	Std. .010 .020 .030 Chrome	499907 499908 499909 499910 -	399671	490652	295871 Note U	692188 Note C	490179	691794 EX 261055S IN
27803S	398811	-	-	222698S	497141	391086S Mag 391086S PTO	690014 690015 690016 690017	Std. .010 .020 .030	499960 499961 499962 499963	399671	490652	498144	693389	498144	691794 EX 261055S IN
27803S	298968	294628	See Breaker Assy.	222698S	692304 393010S	294606S Mag 391086S PTO	499921 690018 690019 690020 299743	Std. .010 .020 .030 Chrome	499907 499908 499909 499910 -	399671	490652	295871 Note U	692188 Note C	490179	691794 EX 261055S IN
27803S	398811	-	-	222698S	692304 393010S 494221 494222	294606S Mag 391086S PTO	499921 690018 690019 690020 299743	Std. .010 .020 .030 Chrome	499907 499908 499909 499910 -	399671	490652	295871 Note U	692188 Note C	490179	691794 EX 261055S IN
27803S	298968 Note D 398811 Note E	294628	See Breaker Assy.	222698S	692304 393010S 496892 494222	294606S Mag 391086S PTO	499921 690018 690019 690020 299743	Std. .010 .020 .030 Chrome	499907 499908 499909 499910 -	399671	490652	295871 Note U	692188 Note C	490179	23835 EX 23836 IN
27803S	298968 Note D 398811 Note E	294628	See Breaker Assy.	222698S	692304 393010S 691971	294606S Mag 391086S PTO	499921 690018 690019 690020 299743	Std. .010 .020 .030 Chrome	499907 499908 499909 499910 -	399671	490652	295871 Note U	Note C	490179	691794 EX 261055S IN
27803S	398811	-	-	222698S	691951 692025 497141	391086S Mag 391086S PTO	690014 690015 690016 690017 299743	Std. .010 .020 .030 Chrome	499907 499908 499909 499910 -	399671	490652	295871 Note U	692188 Note C	490179	691794 EX 261055S IN
27803S	398811	-	-	222698S	692304 393010S 691971 494222	294606S Mag 391086S PTO	690014 690015 690016 690017 299743	Std. .010 .020 .030 Chrome	499907 499908 499909 499910 -	399671	490652	295871 Note U	692188 Note C	490179	691794 EX 261055S IN
27803S	398811	-	-	222698S	692304 393010S 691971 494222	294606S Mag 391086S PTO	690014 690015 690016 690017 299743	Std. .010 .020 .030 Chrome	499907 499908 499909 499910 -	399671	490652	295871 Note U	692188 Note C	490179	691794 EX 261055S IN
27803S	398811	-	-	222698S	692304 393010S 691971 494222	294606S Mag 391086S PTO	690014 690015 690016 690017 299743	Std. .010 .020 .030 Chrome	499907 499908 499909 499910 -	399671	490652	295871 Note U	692188 Note C	490179	691794 EX 261055S IN
27803S	398811	-	-	222698S	692304 393010S 691971 494222	294606S Mag 391086S PTO	690014 690015 690016 690017 299743	Std. .010 .020 .030 Chrome	499907 499908 499909 499910 -	399671	490652	295871 Note U	692188 Note C	490179	691794 EX 261055S IN
27803S	398811	-	-	222698S	393010S	294606S Mag 391086S PTO	690014 690015 690016 690017 299743	Std. .010 .020 .030 Chrome	499907 499908 499909 499910 -	399671	490652	295871 Note U	692188 Note C	490179	691794 EX 261055S IN
27803S	398811	-	-	222698S	393010S	294606S Mag 391086S PTO	499921 690018 690019 690020 299743	Std. .010 .020 .030 Chrome	499907 499908 499909 499910 -	399671	490652	295871 Note U	692188 Note C	490179	691794 EX 261055S IN
27803S	398811	-	-	222698S	692304 393010S 496892	294606S Mag 391086S PTO	690014 690015 690016 690017 299743	Std. .010 .020 .030 Chrome	499907 499908 499909 499910 -	399671	490652	295871 Note U	692188 Note C	490179	691794 EX 261055S IN











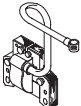

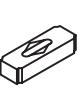
GENUINE PARTS ARE BACKED BY BRIGGS & STRATTON WARRANTY

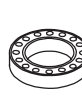

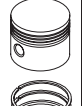
13-30 GENUINE PARTS QUICK REFERENCE



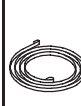













 Engine Model Series	AIR FILTER		FUEL FILTER/OIL FILTER		CARBURETOR				CONN. ROD ASSY.	FUEL TANK CAP	GASKETS				
	Foam	 Cartridge  Pre-Cleaner	 Fuel Filter	 Oil Filter	 Dia- phragm	 Float Valve	 Needle Valve	 Over- haul/ Repair Kit	 Rod Assy.	 Tank Cap	 Air Cleaner	 Carb. to Cylin- der	 Cylin- der Head	 Oil Sump/ Cover	 Set
195400 Type Nos. 0600-1999 Above 2100	-	393957S 271794S	-	-	-	394681 Note AA	292681 (Idle) 99525S (Main)	394693	390401	392305S	-	27828S	272163S	692221 .015 27876 .005 27877 .009	299577
195700	272922	-	298090S 394358S	-	-	494788	494383 (Idle)	497535	390402	493988S	691917	272554S	272163S	692221 .015 27876 .005 27877 .009	299577
196400	-	691643 492889	298090S 394358S	-	-	691782	494383	497578	390401	392305S 493988S	692277	691885	272163S	692221 .015 27876 .005 27877 .009	497070
196700	-	691667 272477S	298090S	-	-	494788	494383 (Idle)	497535	390402	493988S	691917	272554S	272163S	692221 .015 27876 .005 27877 .009	299577
197400	-	691643 No Pre-Cleaner	394358S	-	-	691782	-	Note 2	390401	493988S	692277	272554S	272163S	692221 .015 27876 .005 27877 .009	497070
197700	-	691667 272477S	298090S	-	-	231855S	-	497535	390402	493988S	-	272554S	272163S	692221 .015 27877 .009 27876 .005	299577
198700	-	691667 272477S	298090S	-	-	231855S	-	497535	390402	493988S	-	272554S	272163S	27876	299577
20A400	-	-	-	-	-	696136	-	696146	694691	695737	-	694874	694872	694953	695438
20B400	-	-	-	-	-	-	-	696146	694691	695737	-	694874	694872	694953	-
20C400	-	-	-	-	-	-	-	696146	694691	695737	-	694874	694872	694953	-
20D400	-	-	-	-	-	696136	-	696146	694691	695737	-	694874	694872	694953	695438
20F400	-	-	-	-	-	696136	-	696146	694691	695737	-	694874	694872	694953	695438
200400	270093	-	-	-	-	394681 Note AA	292681 (Idle) 99525S (Main)	394693	299581	69221	67247	65647	27752	692281	294736
201400	-	491588S 493537S	-	-	-	696136	-	696146	694691	694261	692277	694874	694872	694953	695438

GENUINE PARTS QUICK REFERENCE 13-31









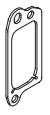
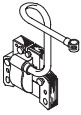

GAS-KETS	IGNITION				MUFFLER	OIL SEALS	PISTON RINGS & PISTON ASSY.			REWIND STARTER					VALVES	
																
Valve Cover	Arma- ture	Breaker Assy.	Con- denser	Fly- wheel Key	Muffler Assy.	Oil Seals	Ring Set	Piston Assy.	Clutch	Grip	Pulley	Rope	Spring	Valves		
27803S	298968 Note D 398811 Note E	294628	See Breaker Assy.	222698S	692304 393010S 494221 494222	294606S Mag 391086S PTO	690014 690015 690016 690017 299743	Std. .010 .020 .030 Chrome	499907 499908 499909 499910 -	399671	490652	295871 Note U	692188 Note C	490179	691794 EX 261055S IN	
27803S	398811	-	-	222698S	691971	294606S Mag 391086S PTO	499921 690018 690019 690020 299743	Std. .010 .020 .030 Chrome	499907 499908 499909 499910 -	399671	490652	295871 Note U	692188 Note C	490179	691794 EX 261055S IN	
27803S	398811	-	-	222698S	498984S 692025 497141	391086S Mag 391086S PTO	499921 690018 690019 690020 299743	Std. .010 .020 .030 Chrome	499907 499908 499909 499910 -	399671	490652	295871 Note U	692188 Note C	490179	691794 EX 261055S IN	
27803S	398811	-	-	222698S	692304 691971 494222	294606S Mag 391086S PTO	499921 690018 690019 690020 299743	Std. .010 .020 .030 Chrome	499907 499908 499909 499910 -	399671	490652	295871 Note U	692188 Note C	490179	691794 EX 261055S IN	
27803S	398811	-	-	222698S	Note 1	391086S Mag 291675S PTO	690014 690015 690016 690017	Std. .010 .020 .030	499960 499961 499962 499963	399671	490652	295871	692188 Cut to Length	490179	691287 EX 261055S IN	
27803S	398811	-	-	222698S	393010S	391086S Mag 391086S PTO	499921 690018 690019 690020 299743	Std. .010 .020 .030 Chrome	499907 499908 499909 499910 -	399671	490652	295871	695002	490179	691794 EX 261055S IN	
27803S	398811	-	-	222698S	393010S	391086S Mag 391086S PTO	499921 690018 690019 690020 299743	Std. .010 .020 .030 Chrome	499907 499908 499909 499910 -	-	490652	498144	693389	498144	691794 EX 261055S IN	
690971	715231	-	-	222698S	696706	391086S Mag 391086S PTO	694004 694006 694008 694010	Std. .010 .020 .030	695457 695458 695459 695460	-	695740	498144	693389	498144	499596 EX 499597 IN	
-	715231	-	-	222698S	696706	391086S Mag 391086S PTO	694004 694006 694008 694010	Std. .010 .020 .030	694003 694005 694007 694009	-	-	-	693389	-	499596 EX 499597 IN	
-	715231	-	-	222698S	696706	391086S Mag 391086S PTO	694004 694006 694008 694010	Std. .010 .020 .030	695457 695458 695459 -	-	-	-	693389	-	499596 EX 499597 IN	
690971	715231	-	-	222698S	696706	391086S Mag 391086S PTO	694004 694006 694008 694010	Std. .010 .020 .030	694003 694005 694007 694009	-	695740	498144	693389	498144	499596 EX 499597 IN	
690971	715231	-	-	222698S	696706	391086S Mag 391086S PTO	694004 694006 694008 694010	Std. .010 .020 .030	694003 694005 694007 694009	-	695740	498144	693389	498144	499596 EX 499597 IN	
66214	298968	298185	298060	222698S	299477S	391086S Mag 391086S PTO	292100 292101 292102 292103 298746	Std. .010 .020 .030 Chrome	294676 294677 294678 294679 -	399671	490652	295871 Note U	692188 Note C	490179	23835 EX 23836 IN	
690971	715231	-	-	222698S	695311	391086S Mag 391086S PTO	694004 694006 694008 694010	Std. .010 .020 .030	695457 695458 695459 695460	-	715257	498144	693389	498144	499596 EX 499597 IN	

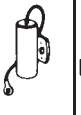
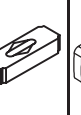

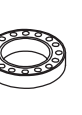
13-32 GENUINE PARTS QUICK REFERENCE



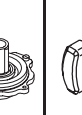

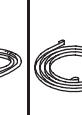
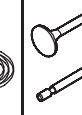











 Engine Model Series	AIR FILTER		FUEL FILTER/OIL FILTER		CARBURETOR				CONN. ROD ASSY.	FUEL TANK CAP	GASKETS				
	Foam	 Cartridge  Pre-Cleaner	 Fuel Filter	 Oil Filter	 Dia- phragm	 Float Valve	 Needle Valve	 Over- haul/ Repair Kit	 Rod Assy.	 Tank Cap	 Air Cleaner	 Carb. to Cylin- der	 Cylin- der Head	 Oil Sump/ Cover	 Set
202400	-	491588S 493537S	-	-	-	696136	-	696146	694691	694261	692277	694874	694872	694953	695438
203400	-	491588S 493537S	694485	-	-	696136	-	696146	694691	694261	692277	694874	694872	694953	695438
204400	-	491588S 493537S	298090S 694485	-	-	696136	-	695441	694691	694261	692277	694874	694872	694953	695438
205400	-	491588S 493537S	298090S 694485	-	-	696136 691782	-	695441	694691	694261	692277	694874	694872	694953	695438
206400	-	695302 695303	694485	-	-	696136 691782	-	695441	694691	694261	-	694874	694872	694953	695438
207400	-	- - -	694485	-	-	696136	-	696146	694691	694261	692277	694874	694872	694953	695438
21A900	-	697152 697292	298090S 394358S	492932S	-	-	498030	697535	697262 697364	-	-	692137	273280S	697110	-
21B900	-	697152 697292	298090S 394358S	492932S	-	231855	498030	697535	697262 697364	-	-	692137	273280S	697110	697151
220400	-	393957S 271794S	-	-	-	394681 Note AA	292681 (Idle) 99525S (Main)	394989 Note DD	393860	392305S	-	498869	271866S	692281 .015 272219 .005 272220 .009	492653
220700	270843S	393725 -	-	-	-	394681 Note AA	292681 (Idle) 396568 (Main) Note EE	394698	393860	394818S 493988S	270853	498869	271866S	271702S .015 270915 .005 270916 .009	393411
221400	-	393957S 271794S	-	-	-	394681 Note AA	292681 (Idle) 99525S (Main)	394989 Note DD	393860	392305S	-	498869	271866S	692281 .015 272219 .005 272220 .009	492653
222400	-	393957S 271794S	-	-	-	394681 Note AA	292681 (Idle) 99525S (Main)	394989 Note DD	393860	297866S	-	498869	271866S	692281 .015 272219 .005 272220 .009	492653
226400	-	691643 492889	-	-	-	691782	494383	497450	393860	392305S 493988S	692277	691886	271866S	692281 .015 272219 .005 272220 .009	497511

GENUINE PARTS QUICK REFERENCE 13-33











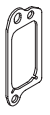
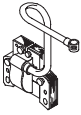

GAS-KETS	IGNITION				MUFFLER	OIL SEALS	PISTON RINGS & PISTON ASSY.			REWIND STARTER					VALVES	
																
Valve Cover	Armature	Breaker Assy.	Condenser	Fly-wheel Key	Muffler Assy.	Oil Seals	Ring Set	Piston Assy.	Clutch	Grip	Pulley	Rope	Spring	Valves		
690971	715231	-	-	222698S	695311	391086S Mag 391086S PTO	694004 694006 694008 694010	Std. .010 .020 .030	694003 694005 694007 694009	-	715257	498144	693389	498144	499596 EX 499597 IN	
690971	715231	-	-	222698S	695311	391086S Mag 391086S PTO	694004 694006 694008 694010	Std. .010 .020 .030	694003 694005 694007 694009	-	715257	498144	693389	498144	499596 EX 499597 IN	
690971	715231	-	-	222698S	695311	391086S Mag 391086S PTO	694004 694006 694008 694010	Std. .010 .020 .030	695457 695458 695459 695460	-	715257	498144	693389	498144	499596 EX 499597 IN	
690971	715231	-	-	222698S	695311	391086S Mag 391086S PTO	694004 694006 694008 694010	Std. .010 .020 .030	694003 694005 694007 694009	-	715257	498144	693389	498144	499596 EX 499597 IN	
690971	715231	-	-	222698S	695311	391086S Mag 391086S PTO	694004 694006 694008 694010	Std. .010 .020 .030	694003 694005 694007 694009	-	715257	498144	693389	498144	499596 EX 499597 IN	
690971	715231	-	-	222698S	695311	391086S Mag 391086S PTO	694004 694006 694008 694010	Std. .010 .020 .030	694003 694005 694007 694009	-	715257	498144	693389	498144	499596 EX 499597 IN	
272475S	492341	-	-	222698S	-	391086S Mag 690947 PTO	697115 697119 697120 697121	Std. .010 .020 .030	697114 697116 697117 697118	-	-	-	-	-	495856 EX 495857 IN	
272475S	492341	-	-	222698S	697048	391086S Mag 690947 PTO	697115 697119 697120 697121	Std. .010 .020 .030	697114 697116 697117 697118	-	-	-	-	-	495856 EX 495857 IN	
27803S	298968	391284	29861	222698S	391569S 691874	391086S Mag 291675S PTO	499996 499997 499998 499999 392331	Std. .010 .020 .030 Chrome	499956 499957 499958 499959 -	399671	490652	295871 Note U	692188 Note C	490179	691796 EX 690429 IN	
27803S	298968 Note D 398811 Note E	391284	29861	222698S	391569S 691874	391086S Mag 291675S PTO	499996 499997 499998 499999 392331	Std. .010 .020 .030 Chrome	499956 499957 499958 499959 -	399671	490652	295871 Note U	692188 Note C	490179	261503 EX 690429 IN	
27803S	298968 Note D 398811 Note E	391284	29861	222698S	391569S 691874 491626	391086S Mag 291675S PTO	391780 391781 391782 391783 392331	Std. .010 .020 .030 Chrome	499284 499288 499292 499296 -	399671	490652	295871 Note U	692188 Note C	490179	691796 EX 690429 IN	
27803S	298968 Note D 398811 Note E	391284	29861	222698S	392989 491626	391086S Mag 291675S PTO	499996 499997 499998 499999 392331	Std. .010 .020 .030 Chrome	499956 499957 499958 499959 -	399671	695740 490652	295871 Note U	692188 Note C	490179	691796 EX Note FF 690429 IN	
27803S	398811	-	-	222698S	497470 497966	391086S Mag 291675S PTO	495854 495852 497524 497525	Std. .010 .020 .030	499284 497519 497520 497521	399671	490652	295871 Note U	692188 Note C	490179	691796 EX 690429 IN	



13-34 GENUINE PARTS QUICK REFERENCE

















 Engine Model Series	AIR FILTER		FUEL FILTER/OIL FILTER		CARBURETOR				CONN. ROD ASSY.	FUEL TANK CAP	GASKETS				
	Foam	 Cartridge  Pre-Cleaner	 Fuel Filter	 Oil Filter	 Dia- phragm	 Float Valve	 Needle Valve	 Over- haul/ Repair Kit	 Rod Assy.	 Tank Cap	 Air Cleaner	 Carb. to Cylin- der	 Cylin- der Head	 Oil Sump/ Cover	 Set
233400 Type Nos. 0010-0350	270093	-	-	-	-	394681 Note AA	292681 (Idle) 99525S (Main)	394693	298400	392305S	67247	27381S	692230	691569	291728
233400 Type Nos. Above 0500	-	393957S 271794S	-	-	-	394681 Note AA	292681 (Idle) 99525S (Main)	395670	298400	392305S	271422	27381S	692230	691569	291728
235400	-	710266 710268	298090S	-	-	231855S	496589	715387	715345	491367S	-	710557	710539	710378	715383
243400	270093	393957S 271794S	298090S 394358S 690612	-	-	394681 Note AA	292681 (Idle) 99525S (Main)	394989 Note HH	299080	392305S	-	27381S	692230	691569	299101
245400	-	710266 710268	298090S 691035	-	-	231855S	496589	715387	715345	491367S	-	710557	710539	710378	715383
250400	-	691643 492889	298090S 691035	-	-	691782	-	497450	490348	Note 1	273101S	691885	271866S	692281 .015 272219 .005 272220 .009	497511
252400	-	392286 393957S 270973 271794S	-	-	-	394681 Note AA	292681 (Idle) 99525S (Main)	394989 Note KK	490348	392305S	-	498869	271866S	692281 .015 272219 .005 272220 .009	492653
252700	270843S	393725S -	-	-	-	394681 Note AA	292681 (Idle) 396568 (Main) Note EE	394698	490348	394818S 493988S	270853	498869	271866S	271702S .015 270915 .005 270916 .009	393411
253400	-	392286 270973	-	-	272638S (Fuel Pump)	394681 Note AA	393541? (Idle) 393542 (Main)	393544	490348	-	280199	270972	272164	692281 .015 272219 .005 272220 .009	492654
253700	270843S	393725 393957S 399806S 271794S	-	-	-	394681 Note AA	292681 (Idle) 396568 (Main) Note EE	394698	490348	394818S 493988S	270853	498869	271866S	271702S .015 270915 .005 270916 .009	393411
254400	-	393957S 399968 271794S 271939	-	-	-	394681 Note AA	292681 (Idle) 99525S (Main)	394989	490348	392305S	271910	498869	271866S	692281 .015 272219 .005 272220 .009	492653
254700	272922	-	-	-	-	494788	494383 (Idle)	495837	490348	493988S	691917	498869	271866S	271702S .015 270915 .005 270916 .009	393411
255400	-	392286 270973	-	-	270988 (Fuel Pump)	394681 Note AA	393542 (Main)	393544	490348	-	280199	270972	272164	692281 .015 272219 .005 272220 .009	492654

GENUINE PARTS QUICK REFERENCE 13-35











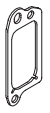
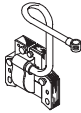

GAS-KETS	IGNITION				MUFFLER	OIL SEALS	PISTON RINGS & PISTON ASSY.			REWIND STARTER					VALVES
															
Valve Cover	Arma- ture	Breaker Assy.	Con- denser	Fly- wheel Key	Muffler Assy.	Oil Seals	Ring Set	Piston Assy.	Clutch	Grip	Pulley	Rope	Spring	Valves	
27803S	298968	298185	298060	222698S	299477S 392989	391086S Mag 391086S PTO	292100 292101 292102 292103 298746	Std. .010 .020 .030 Chrome	294676 294677 294678 294679 -	399671	-	392630 Note U	692188 Note C	490179	394434 EX Note GG 394434 IN Note GG
27803S	298968 Note D 398811 Note E	298185	298060	222698S	299477S 392989 399635	391086S Mag 391086S PTO	292100 292101 292102 292103 298746	Std. .010 .020 .030 Chrome	294676 294677 294678 294679 -	399671	490652	392630 Note U	692188 Note C	490179	394436 EX 394434 IN
710377	715231	-	-	710037	715753	291675S Mag 291675S PTO	715346 715367 715368 -	Std. .010 .020 .030	715793 715795 715797 -	-	490652	692085	692188 Note C	692086	715373 EX 715374 IN
27803S	298968 Note D 398811 Note E	298185	298060	222698S	291519 299477S 392989 399635	391086S Mag 291675S PTO	299089 299090 299091 299092 299744	Std. .010 .020 .030 Chrome	299085 299086 299087 299088 -	399671	490652	392630 Note U	692188 Note C	490179	394436 EX Note JJ 394436 IN Note II
710377	715231	-	-	710037	715753	291675S Mag 291675S PTO	715346 715367 715368 -	Std. .010 .020 .030	715793 715795 715797 -	-	490652	692085	66574 Note C	692086	715373 EX 715374 IN
27803S	398811	-	-	222698S	497470	391086S Mag 391086S PTO	Note 1			399671	490652	295871	692188 Cut to Length	490179	691796 EX 690429 IN
27803S	298968 Note D 398811 Note E	391284	29861	222698S	391569S 392989 691874 491626	391086S Mag 291675S PTO	499996 499997 499998 499999 392331	Std. .010 .020 .030 Chrome	499956 499957 499958 499959 -	399671	490652	295871 Note U	692188 Note C	490179	691796 EX 690429 IN
27803S	298968 Note D 398811 Note E	391284	29861	222698S	391569S 392989 691874	391086S Mag 291675S PTO	499996 499997 499998 499999 392331	Std. .010 .020 .030 Chrome	499956 499957 499958 499959 -	399671	490652	295871 Note U	692188 Note C	490179	691796 EX 690429 IN
27803S	298968 Note D 398811 Note E	391284	29861	222698S	498984S 393465	391086S Mag 291675S PTO	499996 499997 499998 499999 392331	Std. .010 .020 .030 Chrome	499956 499957 499958 499959 -	399671	490652	295871 Note U	692188 Note C	490179	691796 EX 690429 IN
27803S	398811	-	-	222698S	391569S 691874	391086S Mag 291675S PTO	499996 499997 499998 499999 392331	Std. .010 .020 .030 Chrome	499284 499288 499292 499296 -	399671	490652	295871 Note U	692188 Note C	490179	691796 EX 690429 IN
27803S	398811	-	-	222698S	391569S 392989 691874 491626	391086S Mag 291675S PTO	499996 499997 499998 499999 392331	Std. .010 .020 .030 Chrome	499284 499288 499292 499296 -	399671	490652	295871 Note U	692188 Note C	490179	691796 EX 690429 IN
27803S	398811	-	-	222698S	691874	391086S Mag 291675S PTO	499996 499997 499998 499999 392331	Std. .010 .020 .030 Chrome	499956 499957 499958 499959 -	399671	490652	295871 Note U	692188 Note C	490179	691796 EX 690429 IN
27803S	398811	-	-	222698S	498984 393465	391086S Mag 291675S PTO	499996 499997 499998 499999 392331	Std. .010 .020 .030 Chrome	499284 499288 499292 499296 -	399671	490652	295871 Note U	692188 Note C	490179	691796 EX 690429 IN

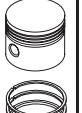

13-36 GENUINE PARTS QUICK REFERENCE

 Engine Model Series	AIR FILTER		FUEL FILTER/OIL FILTER		CARBURETOR				CONN. ROD ASSY.	FUEL TANK CAP	GASKETS				
	Foam	 Cartridge  Pre-Cleaner	 Fuel Filter	 Oil Filter	 Dia- phragm	 Float Valve	 Needle Valve	 Over- haul/ Repair Kit	 Rod Assy.	 Tank Cap	 Air Cleaner	 Carb. to Cylin- der	 Cylin- der Head	 Oil Sump/ Cover	 Set
255700	270843S	-	-	-	-	394681 Note AA	292681 (Idle) 396568 (Main)	394698	490348	493988S	270853	498869	271866S	271702S .015 270915 .005 270916 .009	393411
256400	-	691643 492889	298090S 394358S 690612	-	-	691782	494383	497450	490348	392305S 493988S	273101	691886	271866S	692281 .015 272219 .005 272220 .009	497511
256700	270843	393725 399806S 271962S	-	-	-	394681 Note AA	292681 (Idle) 396568 (Main)	394698	490348	493988S	270853	498869	271866S	271702S .015 270915 .005 270916 .009	393411
257400	-	691643 -	298090S	-	-	691782	498030	497450	490348 490469	-	692277	691885	271866S	272219 .005 272220 .009 692281 .015	497511
257700	-	691667 272477S	-	-	-	494788	494383 (Idle)	495837	490348	493988S	691917	498869	271866S	271702S .015 270915 .005 270916 .009	393411
258700	272922	-	-	-	-	See Illus. Parts List	494383	See Illus. Parts List	490348	493988S	-	498869	271866S	271702S .015 270915 .005 270916 .009	393411
259700	-	691667 272477S	-	-	-	See Illus. Parts List	494383	See Illus. Parts List	490348	493988S	-	498869	271866S	271702S .015 270915 .005 270916 .009	393411
260700	-	491021 272444 492947	-	-	-	492188	492277 (Idle)	492282	492113	-	272031 272469	272029	272126	272124	495260
261700	-	491021 272444 492947	-	-	-	492188	492277 (Idle)	492282	492113	-	272031 272469	272029	272126	272124	495260
28A700	-	691667 -	-	-	-	231855S	496589	497481	490348	-	-	272554S	271866S	692226 .015 692406 .005 692405 .009	494241
28B700	-	691667 272477S	298090S 394358S	-	-	231855S	496589	497481	490348	493988S	-	272554S	271866S	692226 .015 692406 .005 692405 .009	494241
28C700	-	691667 -	-	-	-	231855S	496589	497481	490348	-	-	272554S	271866S	692226 .015 692406 .005 692405 .009	494241
28D700	-	691667 272477S	298090S 394358S	-	-	231855S	496589	497481	490348	-	-	272554S	271866S	692226 .015 692406 .005 692405 .009	494241

















GENUINE PARTS QUICK REFERENCE 13-37

GAS-KETS	IGNITION				MUFFLER	OIL SEALS	PISTON RINGS & PISTON ASSY.			REWIND STARTER					VALVES	
																
Valve Cover	Arma- ture	Breaker Assy.	Con- denser	Fly- wheel Key	Muffler Assy.	Oil Seals	Ring Set	Piston Assy.	Clutch	Grip	Pulley	Rope	Spring	Valves		
27803S	398811	-	-	222698S	391569S 691874	391086S Mag 291675S PTO	499996 499997 499998 499999 392331	Std. .010 .020 .030 Chrome	499956 499957 499958 499959 -	399671	490652	295871 Note U	692188 Note C	490179	691796 690429	EX IN
27803S	398811	-	-	222698S	497470	391086S Mag 291675S PTO	495854 497523 497524 497525	Std. .010 .020 .030	499285 497519 497520 497521	399671	490652	295871 Note U	692188 Note C	490179	691796 690429	EX IN
27803S	398811	-	-	222698S	391569S 691874	391086S Mag 291675S PTO	499996 499997 499998 499999 392331	Std. .010 .020 .030 Chrome	499284 499288 499292 499296 -	399671	490652	295871 Note U	692188 Note C	490179	691796 690429	EX IN
27803S	398811	-	-	222698S	497470	391086S Mag 291675S PTO	495854 495852 495851 495855	Std. .010 .020 .030	499284 499288 499292 -	-	490652	498144	692188	498144	691796 690429	EX IN
27803S	398811	-	-	222698S	691874	391086S Mag 291675S PTO	499996 499997 499998 499999 392331	Std. .010 .020 .030 Chrome	499956 499957 499958 499959 -	399671	490652	295871 Note U	692188 Note C	490179	691796 690429	EX IN
27803S	398811	-	-	222698S	391569S 691874	391086S Mag 291675S PTO	499996 499997 499998 499999 392331	Std. .010 .020 .030 Chrome	499956 499957 499958 499959 -	399671	490652	295871 Note U	692188 Note C	490179	691796 690429	EX IN
27803S	398811	-	-	222698S	691874	391086S Mag 291675S PTO	499996 499997 499998 499999 392331	Std. .010 .020 .030 Chrome	499956 499957 499958 499959 -	399671	490652	295871 Note U	692188 Note C	490179	691796 690429	EX IN
272010 Rocker Cover	492341	-	-	222698S	493626 491692 491796	491019 Mag 491019 PTO	492111 492936 492937 492938	Std. .010 .020 .030	492110 492933 492934 492935	-	490652	494956	695002 Note C	492194	492117 492116	EX IN
272010 Rocker Cover	492341	-	-	222698S	493626 491692 491796	491019 Mag 491019 PTO	492111 492936 492937 492938	Std. .010 .020 .030	492110 492933 492934 492935	-	490652	494956	695002 Note C	492194	492117 492116	EX IN
27803S	492341	-	-	222698S	691874	391086S Mag 291675S PTO	499996 499997 499998 499999 392331	Std. .010 .020 .030 Chrome	499956 499957 499958 499959 -	399671	490652	295871 Note U	692188 Note C	490179	262246 S 262247S	EX IN
27803S	492341	-	-	222698S	691874	391086S Mag 291675S PTO	499996 499997 499998 499999 392331	Std. .010 .020 .030 Chrome	499284 499288 499292 499296 -	399671	490652	295871 Note U	692188 Note C	490179	262246S 262247S	EX IN
27803S	492341	-	-	222698S	See Illus. Parts List	391086S Mag 291675S PTO	499996 499997 499998 499999 392331	Std. .010 .020 .030 Chrome	499956 499957 499958 499959 -	399671	490652	295871 Note U	692188 Note C	490179	262246S 262247S	EX IN
27803S	492341	-	-	222698S	See Illus. Parts List	391086S Mag 291675S PTO	499996 499997 499998 499999 392331	Std. .010 .020 .030 Chrome	499284 499288 499292 499296 -	399671	490652	295871 Note U	692188 Note C	490179	262246S 262247S	EX IN











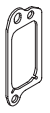
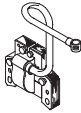



GENUINE PARTS KEEP THE POWER IN POWER EQUIPMENT



13-38 GENUINE PARTS QUICK REFERENCE

 Engine Model Series	AIR FILTER		FUEL FILTER/OIL FILTER		CARBURETOR				CONN. ROD ASSY.	FUEL TANK CAP	GASKETS				
	Foam	 Cartridge  Pre-Cleaner	 Fuel Filter	 Oil Filter	 Dia- phragm	 Float Valve	 Needle Valve	 Over- haul/ Repair Kit	 Rod Assy.	 Tank Cap	 Air Cleaner	 Carb. to Cylin- der	 Cylin- der Head	 Oil Sump/ Cover	 Set
28E700	-	496894S -	-	-	-	231855S	495932	497535	494504S	-	-	272569S	273280S	692226 .015 692406 .005 692405 .009	495993
28M700	-	496894S 272403S	298090S 394358S	-	-	231855S	494383	497535	490348	-	-	272554S	271866S	692226 .015 692406 .005 692405 .009	494241
28N700	-	496894S 272403S	298090S 394358S	492932S	-	231855S	495932	497535	494504S	-	-	272569S	273280S	692226 .015 692406 .005 692405 .009	495993
28P700	-	496894S 272403S	298090S 394358S	491056S 492932S	-	231855S	495932	497535	494504S	-	-	272569S	273280S	692226 .015 692406 .005 692405 .009	495993
28Q700	-	496894S 272403S	298090S 394358S	491056S 492932S	-	231855S	495932	497535	494504S	-	-	272569S	273280S	692226 .015 692406 .005 692405 .009	495993
28R700	-	496894S 272403S	298090S 394358S	-	-	231855S	-	Note 1	490348	Note 4	691917	692284	271866S	692226 .015 692406 .005 692405 .009	494241
28S700	-	496894S 272403S	298090S 394358S	491056S 492932S	-	231855S	-	690191	494504S	Note 4	691917	692137	273280S	692226 .015 692406 .005 692405 .009	691580
28T700	-	496894S 272403S	298090S	-	-	231855S	-	499220	494504S	Note 4	691917	692284	271866S	692226 .015 692406 .005 692405 .009	494241
28U700	-	496894S 272403S	394358S	-	-	231855	498030	690191 695427	692419	-	-	272569S 692137	273280S	692226	691580
28V700	-	496894S 272403S	-	-	-	231855	498030	499220	494504S	-	-	272554S 692284	271866S	692226	494241
28W700	-	496894S 272403S	298090S	-	-	231855	498030	690191 695427	692419	-	-	692137	273280S	692226	691580
280700	-	399806S 271962S	-	-	-	394681 Note AA	292681 (Idle) 396568 (Main)	394698	490348	493988S	270853	498869	271866S	692226 .015 692406 .005 692405 .009	494241
281700	-	399806S 271962S	-	-	-	394681 Note AA	292681 (Idle) 396568 (Main)	394698	490348	493988S	270853	498869	271866S	692226 .015 692406 .005 692405 .009	494241
282700	-	496894S -	-	-	-	494788	494383 (Idle)	497535	490348	-	691917	498869	271866S	692226 .015 692406 .005 692405 .009	494241

















GENUINE PARTS QUICK REFERENCE 13-39

GAS-KETS	IGNITION				MUFFLER	OIL SEALS	PISTON RINGS & PISTON ASSY.			REWIND STARTER					VALVES	
																
Valve Cover	Armature	Breaker Assy.	Condenser	Fly-wheel Key	Muffler Assy.	Oil Seals	Ring Set	Piston Assy.	Clutch	Grip	Pulley	Rope	Spring	Valves		
272475S	492341	-	-	222698S	496022S	391086S Mag 291675S PTO	495854 495852 495851 495855	Std. .010 .020 .030	499284 499288 499292 499296	-	-	-	-	-	495856 495857	EX IN
27803S	492341	-	-	222698S	See Illus. Parts List	391086S Mag 291675S PTO	499996 499997 499998 499999 392331	Std. .010 .020 .030 Chrome	499284 499288 499292 499296 -	-	-	-	-	-	262246S 262247S	EX IN
272475S	492341	-	-	222698S	495805S	391086S Mag 291675S PTO	495854 495852 495851 495855	Std. .010 .020 .030	499284 499288 499292 499296	-	-	-	-	-	495856 495857	EX IN
272475S	492341	-	-	222698S	690850	391086S Mag 291675S PTO	495854 495852 495851 495855	Std. .010 .020 .030	499284 499288 499292 499296	-	-	-	-	-	495856 495857	EX IN
272475S	492341	-	-	222698S	690850	391086S Mag 291675S PTO	495854 495852 495851 495855	Std. .010 .020 .030	499284 499288 499292 499296	-	-	-	-	-	495856 495857	EX IN
27803S	492341	-	-	222698S	Note 4	391086S Mag 291675S PTO	499996 499997 499998 499999	Std. .010 .020 .030	499284 499288 499292 499296	-	-	-	-	-	691811 262247S	EX IN
27803S	492341	-	-	222698S	Note 4	391086S Mag 291675S PTO	495854 495852 495851 495855	Std. .010 .020 .030	499284 499288 499292 499296	-	-	-	-	-	495856 495857	EX IN
27803S	492341	-	-	222698S	Note 4	391086S Mag 291675S PTO	499996 499997 499998 499999	Std. .010 .020 .030	499284 499288 499292 499296	-	-	-	-	-	495856 495857	EX IN
272475	492341	-	-	222698S	-	391086S Mag 291675S PTO	696403 696404 696405 696406	Std. .010 .020 .030	696397 696398 696399 696400	-	-	-	-	-	495856 495857	EX IN
27803S	492341	-	-	222698S	-	391086S Mag 291675S PTO	499996 499997 499998 499999 392331	Std. .010 .020 .030 Chrome	499284 499288 499292 499296 -	-	-	-	-	-	262246S 262247 S	EX IN
272475	492341	-	-	222698S	-	391086S Mag 291675S PTO	495854 495852 495851 495855	Std. .010 .020 .030	499284 499288 499292 499296	-	-	-	-	-	495856 495857	EX IN
27803S	492341 Note LL	-	-	222698S	391569S 392989 490600 691874	391086S Mag 291675S PTO	499996 499997 499998 499999 392331	Std. .010 .020 .030 Chrome	499956 499957 499958 499959 -	-	490652	295871 Note U	692188 Note C	490179	262246S 262247 S	EX IN
27803S	492341 Note LL	-	-	222698S	391569S 392989 490600 691874	391086S Mag 291675S PTO	499996 499997 499998 499999 392331	Std. .010 .020 .030 Chrome	499284 499288 499292 499296 -	-	490652	295871 Note U	692188 Note C	490179	262246S 262247 S	EX IN
27803S	492341	-	-	222698S	-	391086S Mag 291675S PTO	499996 499997 499998 499999 392331	Std. .010 .020 .030 Chrome	499956 499957 499958 499959 -	-	-	-	-	-	262246S 262247 S	EX IN









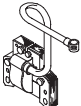

GENUINE PARTS ARE THE RIGHT PARTS FOR THE RIGHT JOB

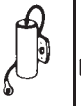
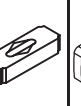

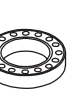
13-40 GENUINE PARTS QUICK REFERENCE

 Engine Model Series	AIR FILTER		FUEL FILTER/OIL FILTER		CARBURETOR				CONN. ROD ASSY.	FUEL TANK CAP	GASKETS				
	Foam	 Cartridge  Pre-Cleaner	 Fuel Filter	 Oil Filter	 Dia- phragm	 Float Valve	 Needle Valve	 Over- haul/ Repair Kit	 Rod Assy.	 Tank Cap	 Air Cleaner	 Carb. to Cylin- der	 Cylin- der Head	 Oil Sump/ Cover	 Set
283700	-	496894S 272403S	298090S 394358S	-	-	494788	494383 (Idle)	497535	490348	-	691917	498869	271866S	692226 .015 692406 .005 692405 .009	494241
284700	-	496894S -	298090S 394358S	-	-	231855S	494383	497535	490348	-	-	272554S	271866S	692226 .015 692406 .005 692405 .009	494241
285700	-	496894S -	-	-	-	See Illus. Parts List	494383	See Illus. Parts List	490348	-	-	272554S	271866S	692226 .015 692406 .005 692405 .009	494241
286700	-	496894S 272403S	298090S 394358S	-	-	494788	494383 (Idle)	497535	490348	493988S	691917	498869	271866S	692226 .015 692406 .005 692405 .009	494241
287700	-	496894S 272403S	298090S 394358S	492932S	-	231855S	495932	497535	494504S	-	-	272569S	273280S	692226 .015 692406 .005 692405 .009	495993
288700	-	496894S -	-	-	-	231855S	494383	497535	490348	-	-	272554S	271866S	692226 .015 692406 .005 692405 .009	494241
289700	-	496894S 272403S	298090S 394358S	-	-	See Illus. Parts List	494383	See Illus. Parts List	490348	493488	-	272554S	271866S	692226 .015 692406 .005 692405 .009	494241
290400	-	393957S 394018S 805113 272490S 271794S 805267S	-	-	-	808798	808257 (Idle)	809021	807900S (2 used)	491367S	692052 692081	692035 (2 used)	807986 (2 used)	691684	808390
290700	-	394018S 805113 272490S 805267S	-	-	-	807706	Note 1	807708	807900S (2 used)	-	692052 692081	692035 (2 used)	807986 (2 used)	691684	808390
294400	-	393957 394018S 805113 272490S 271794S 805267S	298090S 691035 808116S	491056S 492932S	-	Note 1	Note 1	809021	807900S (2 used)	491367S	692052 692081	692035 (2 used)	807986 (2 used)	691684	808390
294700	-	394018S 805113 272490S 805267S	394358S 691035	491056S 492932S	-	807706	Note 1	807708	807900S (2 used)	-	692052 692081	692035 (2 used)	807986 (2 used)	691684	808390
300400	270093	-	-	-	-	394681	292681 (Idle) 99525S (Main)	299720	299632	69221	-	27381S	692231	691569	299719

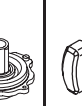

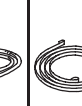
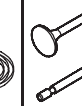













GENUINE PARTS QUICK REFERENCE 13-41

GAS-KETS	IGNITION				MUFFLER	OIL SEALS	PISTON RINGS & PISTON ASSY.			REWIND STARTER					VALVES
															
Valve Cover	Armature	Breaker Assy.	Condenser	Fly-wheel Key	Muffler Assy.	Oil Seals	Ring Set	Piston Assy.	Clutch	Grip	Pulley	Rope	Spring	Valves	
27803S	492341	-	-	222698S	-	391086S Mag 291675S PTO	499996 499997 499998 499999 392331	Std. .010 .020 .030 Chrome	499284 499288 499292 499296 -	399671	490652	295871 Note U	692188 Note C	490179	262246S EX 262247 S IN
27803S	492341	-	-	222698S	See Illus. Parts List	391086S Mag 291675S PTO	499996 499997 499998 499999 392331	Std. .010 .020 .030 Chrome	499284 499288 499292 499296 -	-	-	-	-	-	262246S EX 262247S IN
27803S	492341	-	-	222698S	See Illus. Parts List	391086S Mag 291675S PTO	499996 499997 499998 499999 392331	Std. .010 .020 .030 Chrome	499956 499957 499958 499959 -	-	-	-	-	-	262246S EX 262247S IN
27803S	492341	-	-	222698S	694515	391086S Mag 291675S PTO	499996 499997 499998 499999 392331	Std. .010 .020 .030 Chrome	499284 499288 499292 499296 -	399671	490652	295871 Note U	692188 Note C	490179	262246S EX 262247 S IN
272475S	492341	-	-	222698S	495805S 496022S	391086S Mag 291675S PTO	495854 495852 495851 495855	Std. .010 .020 .030	499284 499288 499292 499296	-	-	-	-	-	495856 EX 495857 IN
27803S	492341	-	-	222698S	See Illus. Parts List	391086S Mag 291675S PTO	499996 499997 499998 499999 392331	Std. .010 .020 .030 Chrome	499284 499288 499292 494296 -	-	-	-	-	-	262246S EX 262247S IN
27803S	492341	-	-	222698S	694515	391086S Mag 291675S PTO	499996 499997 499998 499999 392331	Std. .010 .020 .030 Chrome	499284 499288 499292 494296 -	399671	490652	295871 Note U	692188 Note C	490179	262246S EX 262247S IN
806039S (2 used)	492341 (2 used)	-	-	808095	See Illus. Parts List	805101S Mag 805049S PTO	807620 807808 807810 807812	Std. .010 .020 .030	807619 807807 807809 807811	-	490652	280918	695002 Note C	492194	807681 EX (2 used) 807680 IN (2 used)
806039S (2 used)	492341 (2 used)	-	-	808095	See Illus. Parts List	805101S Mag 805049S PTO	807620 807808 807810 807812	Std. .010 .020 .030	807619 807807 807809 807811	-	490652	280918	692188 Note C	492194	807681 EX (2 used) 807680 IN (2 used)
806039S (2 used)	492341 (2 used)	-	-	808095	See Illus. Parts List	805101S Mag 805049S PTO	807620 807808 807810 807812 - Chrome (2 used)	Std. .010 .020 .030	807619 807807 807809 807811 -	-	490652	280918	692188 Note C	492194	807681 EX (2 used) 807680 IN (2 used)
806039S (2 used)	492341 (2 used)	-	-	808095	See Illus. Parts List	805101S Mag 805049S PTO	807620 807808 807810 807812	Std. .010 .020 .030	807619 807807 807809 807811	-	490652	280918	692188 Note C	492194	807681 EX (2 used) 807680 IN (2 used)
27803S	298968	298185	298060	222698S	299477S	691948 Mag 691948 PTO	299690 299710 299711 299712 299745	Std. .010 .020 .030 Chrome	299688 299716 299717 299718 -	-	-	-	-	-	394436 EX 394435 IN











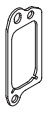
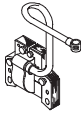

GENUINE PARTS ARE THE RIGHT PARTS FOR THE RIGHT JOB

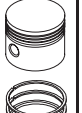

13-42 GENUINE PARTS QUICK REFERENCE

















 Engine Model Series	AIR FILTER		FUEL FILTER/OIL FILTER		CARBURETOR				CONN. ROD ASSY.	FUEL TANK CAP	GASKETS				
	Foam	 Cartridge  Pre-Cleaner	 Fuel Filter	 Oil Filter	 Dia- phragm	 Float Valve	 Needle Valve	 Over- haul/ Repair Kit	 Rod Assy.	 Tank Cap	 Air Cleaner	 Carb. to Cylin- der	 Cylin- der Head	 Oil Sump/ Cover	 Set
302400	-	393957S 271794S	-	-	-	394681	292681 (Idle) 99525 (Main)	391071	299632	392305S	67247	27381S	692231	691569	299719
303400	-	393957S 394018S 805113 272490S 271794S 805267S	298090S 691035 808116S	491056 492932S	-	808798 Check Type # S	808257 (Idle)	809021	807900S (2 used)	491367S	692052 692081	692035 (2 used)	807986 (2 used)	691684	808390
303700	-	394018S 805113 272490S 805267S	394358S 691035	491056 492932S	-	807706	808257 (Idle)	Note 2	807900S (2 used)	-	692052 692081	692035 (2 used)	807986 (2 used)	691684	808390
31F700	-	697014 697015	298090S 394358S 691035	492932S	-	-	498030	697154 697241	-	-	-	692137	692410	697110	-
310700	-	496894S 272403S	298090S 394358S	492932S	-	231855S	498030	690191	692419	Note 4	691917	692137	692410	692226 .015 692406 .005 692405 .009	690189
311700	-	496894S 272403S	298090S 394358S	492932S	-	231855S	498030	690191	692419	Note 4	691917	692137	692410	692226 .015 692406 .005 692405 .009	690189
312700	-	496894S 272403S	298090S 394358S	492932S	-	231855S	498030	690191	692419	Note 4	691917	692137	692410	692226 .015 692406 .005 692405 .009	690189
313700	-	496894S 272403S	298090S	492932S	-	231855S	498030	690191 695427	692419	-	-	692137	692410	692226	690189
320400	270093	-	-	-	-	394681	292681 (Idle) 99525S (Main)	299720	299632	69221	-	27381S	807986	691684	299719
326400	-	393957S 271794S	298090S 394358S 691035	-	-	394681 Note AA	292681 (Idle) 99525S (Main)	394989 Note VV	299632	392305S	-	27381S	692231	691569	299719
327400	-	-	690612	-	-	394681	292681	NLA	NLA	392305S	-	NLA	692231	691569	NLA
350400	-	394018S 272490S	298090S 394358S 691035 808116S	491056 492932S	-	Note 2	Note 1 Note 2	809024	807900S (2 used)	-	692081	692035	805653S (2 used)	691684	808389
350700	-	394018S 272490S	394358S 691035	491056 492932S	-	See Illus. Parts List	See Illus. Parts List	See Illus. Parts List	807900S (2 used)	-	692081	692035 (2 used)	805653S (2 used)	691684	808389
351400	-	394018S 272490S	691035	491056 492932S	-	808798	See Illus. Parts List	See Illus. Parts List	807900S (2 used)	-	692087	692035 (2 used)	805653S (2 used)	691684	808389

GENUINE PARTS QUICK REFERENCE 13-43











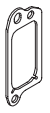
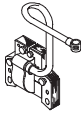

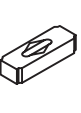
GAS-KETS	IGNITION				MUFF-LER	OIL SEALS	PISTON RINGS & PISTON ASSY.			REWIND STARTER					VALVES	
																
Valve Cover	Arma-ture	Breaker Assy.	Con-denser	Fly-wheel Key	Muffler Assy.	Oil Seals	Ring Set	Piston Assy.	Clutch	Grip	Pulley	Rope	Spring	Valves		
27803S	298968	298185	298060	222698S	299477S	691948 Mag PTO	299690 299710 299711 299712 299745	Std. .010 .020 .030 Chrome	299688 299716 299717 299718 -	399671	490652	392630 Note U	692188 Note C	490179	394436 394435	EX IN
806039S (2 used)	492341 (2 used)	-	-	808095	See Illus. Parts List	805101S Mag 805049S PTO	807620 807808 807810 807812 -	Std. .010 .020 .030 -	807619 807807 807809 807811 -	-	490652	280918	692188 Note C	492194	807681 (2 used) 807680 (2 used)	EX IN
806039S (2 used)	492341 (2 used)	-	-	808095	See Illus. Parts List	805101S Mag 805049S PTO	807620 807808 807810 807812	Std. .010 .020 .030	807619 807807 807809 807811	-	490652	280918	692188 Note C	492194	807681 (2 used) 807680 (2 used)	EX IN
697109	492341	-	-	222698S	-	391086S Mag 691948 PTO	697164 697165 - -	Std. .010 .020 .030	697159 697160 697162 697163	-	-	-	-	-	696986 495857	EX IN
27803S	492341	-	-	222698S	-	391086S Mag 291675S PTO	690162 690164 690166 690168	Std. .010 .020 .030	692271 692272 692273 692274	-	-	-	-	-	696986 495857	EX IN
27803S	492341	-	-	222698S	690850	391086S Mag 291675S PTO	690162 690164 690166 690168	Std. .010 .020 .030	692271 692272 692273 692274	-	-	-	-	-	696986 495857	EX IN
27803S	492341	-	-	222698S	-	391086S Mag 291675S PTO	690162 690164 690166 690168	Std. .010 .020 .030	692271 692272 692273 692274	-	-	-	-	-	696986 495857	EX IN
27803S	492341	-	-	222698S	-	391086S Mag 291675S PTO	690162 690164 690166 690168	Std. .010 .020 .030	692271 692272 692273 692274	-	-	-	-	-	696986 495857	EX IN
27803S	298968	298185	298060	222698S	299477S	691948 Mag PTO	390484 390486 390505 390507 390679	Std. .010 .020 .030 Chrome	390364 390365 390366 390367 -	-	-	-	-	-	394436 394435	EX IN
27803S	298968 Note D 398811 Note E	298185	298060	222698S	299477S 392989 393232S 399635	691948 Mag PTO	390484 390486 390505 390507 390679	Std. .010 .020 .030 Chrome	390364 390365 390366 390367 -	393127S 399671	490652	392630 Note U 295871 Note U	695002 Note C	490179	394436 394435	EX IN
27803S	398811	-	-	222698S	-	691948 PTO	390484 390486 390505 390507 390679	Std. .010 .020 .030 Chrome	390364 390365 390366 390367 -	-	-	691151	69932S	-	394436 394435	EX IN
806039S (2 used)	492341 (2 used)	-	-	808095	See Illus. Parts List	805101S Mag 805049S PTO	807889	Std. (2 used)	808326	-	490652	280918	695002 Note C	492194	807681 (2 used) 807680 (2 used)	EX IN
806039S (2 used)	492341 (2 used)	-	-	808095	See Illus. Parts List	805101S Mag 805049S PTO	807889	Std. (2 used)	808326	-	490652	280918	695002 Note C	492194	807681 (2 used) 807680 (2 used)	EX IN
806039S (2 used)	492341	-	-	808095	692099 691562	805101S Mag 805049S PTO	807889 807994 807995 807996	Std. .010 .020 .030	808326 808336 808337 808338	-	808167	692085	66574	692086	807681 (2 used) 807680 (2 used)	EX IN

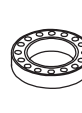

13-44 GENUINE PARTS QUICK REFERENCE

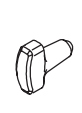
 Engine Model Series	AIR FILTER		FUEL FILTER/OIL FILTER		CARBURETOR				CONN. ROD ASSY.	FUEL TANK CAP	GASKETS				
	Foam	 Cartridge  Pre-Cleaner	 Fuel Filter	 Oil Filter	 Dia- phragm	 Float Valve	 Needle Valve	 Over- haul/ Repair Kit	 Rod Assy.	 Tank Cap	 Air Cleaner	 Carb. to Cylin- der	 Cylin- der Head	 Oil Sump/ Cover	 Set
351700	-	394018S 272490S	691035	491056 492932S	-	808798	See Illus. Parts List	808265	807900S (2 used)	-	692087	692035 (2 used)	805653S (2 used)	691684	808389
354400	-	394018S 272490S	-	492932S	-	-	-	-	807900S	-	692081	692035	690888	691684	808704
380400	-	692519 692520	691035	492932S	-	808798	-	808816	808646	Note 4	692087	690950	806377	691684	808617
380700	-	692519 692520	691035	492932S	-	808798	-	808816	808646	Note 4	692087	690950	806377	691684	808617
381400	-	692519 692520	691035	492932S	-	808798	808257	808816	808646	-	692087	690950	806377	691684	808617
381700	-	692519 692520	691035	492932S	-	808798	808257	808816	808646	-	692087	690950	806377	691684	808617
384400	-	394018S 272490S	-	492932S	-	-	-	-	808646	-	692081	692035	806377	691684	809074
40A700	-	394019S 272490S	-	-	272638S (Fuel Pump)	394683	491538 (Idle)	694056	393270 (2 used)	-	690273	692219 (2 used)	271867S Cyl. #1 271868S Cyl. #2	692292 .015 271188 .005 271189 .009	495868
400400	-	394018S 272490S	-	-	272638S (Fuel Pump)	394681	292681 (Idle) Note MM	694056	393270 (2 used) Note SS	-	690273	692219 (2 used)	271867S Cyl. #1 271868S Cyl. #2	691877 .015 272127 .005 272128 .009 Note UU	495868 Note WW
400700	-	394019S 272490S	-	-	272638S (Fuel Pump)	394681	292681 (Idle) Note MM	694056	393270 (2 used) Note SS	-	690273	692219 (2 used)	271867S Cyl. #1 271868S Cyl. #2	692292 .015 271188 .005 271189 .009	495868 Note WW
401400	-	394018S 272490S	-	-	272638S (Fuel Pump)	394681	292681 (Idle)	694056	393270 (2 used)	-	690273	692219 (2 used)	271867S Cyl. #1 271868S Cyl. #2	691877 .015 272127 .005 272128 .009	495868 Note WW
401700	-	394019S 272490S	-	-	272638S (Fuel Pump)	394681	292681 (Idle)	694056	393270 (2 used)	-	690273 Note NN	692219 (2 used)	271867S Cyl. #1 271868S Cyl. #2	692292 .015 271188 .005 271189 .009	495868 Note WW
402400	-	394018S 272490S	-	-	272638S (Fuel Pump)	394681 Note OO	292681 (Idle) Note PP	694056	393270 (2 used) Note SS	-	690273	692219 (2 used)	271867S Cyl. #1 271868S Cyl. #2	691877 .015 272127 .005 272128 .009 Note UU	495868 Note WW
402700	-	394019S 272490S	-	-	272638S (Fuel Pump)	394681	491538	694056	393270 (2 used) Note SS	-	690273	692219 (2 used)	271867S Cyl. #1 271868S Cyl. #2	692292 .015 271188 .005 271189 .009	495868 Note WW
404400	-	394018S 272490S	-	-	272638S (Fuel Pump)	394681	292681 (Idle)	694056	393270 (2 used)	-	690273	692219 (2 used)	271867S Cyl. #1 271868S Cyl. #2	691877 .015 272127 .005 272128 .009	495868 Note WW

















GENUINE PARTS QUICK REFERENCE 13-45

GAS-KETS	IGNITION				MUFF-LER	OIL SEALS	PISTON RINGS & PISTON ASSY.			REWIND STARTER					VALVES
															
Valve Cover	Arma-ture	Breaker Assy.	Con-denser	Fly-wheel Key	Muffler Assy.	Oil Seals	Ring Set	Piston Assy.	Clutch	Grip	Pulley	Rope	Spring	Valves	
806039S (2 used)	492341 (2 used)	-	-	808095	See Illus. Parts List	805101S Mag 805049S PTO	807889 807994 807995 807996	Std. .010 .020 .030	808326 808336 808337 808338	-	-	-	-	-	807681 EX (2 used) 807680 IN (2 used)
806039S	492341	-	-	808095	691562 692099	805101S Mag 805049S PTO	807889 807994 807995 807996	Std. .010 .020 .030	808326 808336 808337 808338	-	808167	692085	66574	692086	808687 EX 807680 IN
-	492341	-	-	808095	-	805101S Mag 805049S PTO	808528	Std.	808527	-	-	-	-	-	806419 EX (2 used) 806420 IN (2 used)
-	492341	-	-	808095	-	805101S Mag 805049S PTO	808528	Std.	808527	-	-	-	-	-	806419 EX (2 used) 806420 IN (2 used)
806039S	492341	-	-	808095	808705 808896	805101S Mag 805049S PTO	808528 808660 808661 808662	Std. .010 .020 .030	808527 808535 808652 808653	-	808167	692085	66574	692086	806419 EX 806420 IN
806039S	492341	-	-	808095	498984S	805101S Mag 805049S PTO	808528 808660 808661 808662	Std. .010 .020 .030	808527 808535 808652 808653	-	808167	692085	66574	692086	806419 EX 806420 IN
806039S	492341	-	-	808095	-	805101S Mag 805049S PTO	808528 808660 808661 808662	Std. .010 .020 .030	808527 808535 808652 808653	-	-	-	-	-	809069 EX 806420 IN
27803S (2 used)	394891	-	-	222698S	See Illus. Parts List	391086S Mag 291675S PTO	394959 394960 394961 394962	Std. .010 .020 .030	498584 498585 498586 498587	-	-	-	-	-	691794 EX (2 used) 691804 IN (2 used)
27803S (2 used)	394891	-	-	222698S	399635 (2 used)	391086S Mag 291675S PTO	394959 394960 394961 394962	Std. .010 .020 .030	498584 498585 498586 498587	-	-	-	-	-	691794 EX (2 used) 691804 IN (2 used)
27803S (2 used)	394891	-	-	222698S	491319S	391086S Mag 291675S PTO	394959 394960 394961 394962	Std. .010 .020 .030	498584 498585 498586 498587	-	-	-	-	-	691794 EX (2 used) 691804 IN (2 used)
27803S (2 used)	392329 Note D 394891 Note E	-	392912	222698S	691951 (2 used) 399635 (2 used) 491307S	391086S Mag 291675S PTO	393277 393340 393341 393342	Std. .010 .020 .030	499956 499957 499958 499959	-	-	-	-	-	691794 EX (2 used) 691804 IN (2 used)
27803S (2 used)	392329 Note D 394891 Note E	-	392912	222698S	491319S	391086S Mag 291675S PTO	393277 393340 393341 393342	Std. .010 .020 .030	499956 499957 499958 499959	-	-	-	-	-	691794 EX (2 used) 691804 IN (2 used)
27803S (2 used)	392329 Note D 394891 Note E	-	392912	222698S	392989 399635 (2 used) 491307S	391086S Mag 291675S PTO	394959 394960 394961 394962	Std. .010 .020 .030	498584 498585 498586 498587	-	-	-	-	-	691794 EX (2 used) 691804 IN (2 used)
27803S (2 used)	394891	-	-	222698S	399635 (2 used) 491319S	391086S Mag 291675S PTO	394959 394960 394961 394962	Std. .010 .020 .030	498584 498585 498586 498587	-	-	-	-	-	691794 EX (2 used) 691804 IN (2 used)
27803S (2 used)	394891	-	-	222698S	491307S	391086S Mag 291675S PTO	394959 394960 394961 394962	Std. .010 .020 .030	498584 498585 498586 498587	-	-	-	-	-	691794 EX (2 used) 691804 IN (2 used)









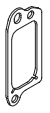
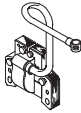

GENUINE DEALERS USE GENUINE PARTS

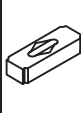

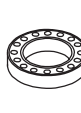
13-46 GENUINE PARTS QUICK REFERENCE

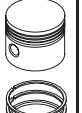
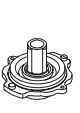
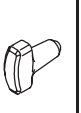

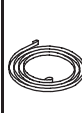











 Engine Model Series	AIR FILTER		FUEL FILTER/OIL FILTER		CARBURETOR				CONN. ROD ASSY.	FUEL TANK CAP	GASKETS				
	Foam	 Cartridge  Pre-Cleaner	 Fuel Filter	 Oil Filter	 Dia- phragm	 Float Valve	 Needle Valve	 Over- haul/ Repair Kit	 Rod Assy.	 Tank Cap	 Air Cleaner	 Carb. to Cylin- der	 Cylin- der Head	 Oil Sump/ Cover	 Set
404700	-	394019S 272490S	-	-	272638S (Fuel Pump)	394681 Note QQ	292681 (Idle) Note RR	694056	393270 (2 used) Note SS	-	690273	692219 (2 used)	271867S Cyl. #1 271868S Cyl. #2	692292 .015 271188 .005 271189 .009	495868 Note WW
405700	-	499486S 273638S	691035	492932S	-	690985	-	499811	499583	-	-	Note 1	690962 (2 used)	690945	694012
406700	-	499486S 273638S	691035	492932S	-	690985	-	499811	499583	-	691001	Note 1	690962 (2 used)	690945	694012
407700	-	499486S 273638S	691035	492932S	-	690985	-	499811	499583	-	691001	Note 1	690962 (2 used)	690945	694012
42A700	-	394019S 272490S	394358S	491056 492932S	691871 (Fuel Pump)	394683	491538	694056	393270 (2 used)	-	690273	692219 (2 used)	271867S Cyl. #1 271868S Cyl. #2	692292 .015 271188 .005 271189 .009	495868
42B700	-	394019S 272490S	394358S	-	691873 693488	394682	491538	693503 694056	394306	-	690273	692219 692278	271867S 271868S	271188 .005 271189 .009 692292 .015	495868
42C700	-	394019S 272490S	-	-	-	394682	-	694056	394306 (2 used)	Note 4	690273	Note 1	271867S Cyl. #1 271868S Cyl. #2	692292 .015 271188 .005 271189 .009	495868
42D700	-	394019S 272490S	394358S	492932S	-	394682	-	694056	394306 (2 used)	Note 4	690273	Note 1	271867S Cyl. #1 271868S Cyl. #2	692292 .015 271188 .005 271189 .009	495868
420700	-	394019S 272490S	-	-	272638S (Fuel Pump)	394683	491538	694056	394306 (2 used)	-	690273	692219 (2 used)	271867S Cyl. #1 271868S Cyl. #2	692292 .015 271188 .005 271189 .009	495868
422400	-	394018S 272490S	394358S 691035 690612	491056 492932S	272638S (Fuel Pump)	394681 Note OO	292681 (Idle) Note PP	694056	394306 (2 used) Note TT	-	690273	692219 (2 used)	271867S Cyl. #1 271868S Cyl. #2	691877 .015 272127 .005 272128 .009	495868 Note WW
422700	-	394019S 272490S	394358S 691035	491056 492932S	272638S (Fuel Pump)	394681 Note OO	292681 (Idle) Note PP	694056	394306 (2 used) Note TT	-	690273	692219 (2 used)	271867S Cyl. #1 271868S Cyl. #2	692292 .015 271188 .005 271189 .009	495868 Note WW
432400	-	820263 -	820311	820314	-	-	-	-	825171	-	-	820407	820658	820137	825212
433400	-	820263 -	-	491056 820314	-	-	825241 825374	825258	825033	-	820385	820087 820385	820650	820137	825056
437400	-	820263 -	692983	491056 820314	-	820506	825374	825438	825033	-	-	820087 820160 820385	820650	820137	825378
445700	-	499486S 273638S	691035	492932S	-	690985	-	499811	499583	-	691001	690949 690950	693997	690945	694012
460700	-	394019S 272490S	394358S	492932S	693489 (Fuel Pump)	Note 1	-	694056	498314	-	-	692278	271867S Cyl. #1 271868S Cyl. #2	692292 .015 271188 .005 271189 .009	495868

GENUINE PARTS QUICK REFERENCE 13-47

GAS-KETS	IGNITION				MUFFLER	OIL SEALS	PISTON RINGS & PISTON ASSY.			REWIND STARTER					VALVES
															
Valve Cover	Armature	Breaker Assy.	Condenser	Fly-wheel Key	Muffler Assy.	Oil Seals	Ring Set	Piston Assy.	Clutch	Grip	Pulley	Rope	Spring	Valves	
27803S (2 used)	394891	-	-	222698S	491319S	391086S Mag 291675S PTO	394959 394960 394961 394962	Std. .010 .020 .030	498584 498585 498586 498587	-	-	-	-	691794 EX (2 used) 691804 IN (2 used)	
-	691060	-	-	222698S	-	391086S Mag 690947 PTO	499604 499605 499606 499607	Std. .010 .020 .030	499588 499589 499590 499591	-	-	-	-	499596 EX (2 used) 499597 IN (2 used)	
690937	691060	-	-	222698S	692120	391086S Mag 690947 PTO	499604 499605 499606 499607	Std. .010 .020 .030	499588 499589 499590 499591	-	-	-	-	499596 EX (2 used) 499597 IN (2 used)	
690937	691060	-	-	222698S	-	391086S Mag 690947 PTO	499604 499605 499606 499607	Std. .010 .020 .030	499588 499589 499590 499591	-	-	-	-	499596 EX 499597 IN	
27803S (2 used)	394891	-	-	222698S	-	391086S Mag 291675S PTO	394959 394960 394961 394962	Std. .010 .020 .030	498584 498585 498586 498587	-	-	-	-	691794 EX (2 used) 691804 IN (2 used)	
27803S	394891	-	-	222698S	690838	391086S Mag 291675S PTO	394959 394960 394961 394962	Std. .010 .020 .030	498584 498585 498586 498587	-	-	-	-	691794 EX 691804 IN	
27803S (2 used)	394891	-	-	222698S	Note 4	391086S Mag 291675S PTO	394959 394960 394961 394962	Std. .010 .020 .030	498584 498585 498586 498587	-	-	-	-	691794 EX 691804 IN	
27803S (2 used)	394891	-	-	222698S	Note 4	391086S Mag 291675S PTO	394959 394960 394961 394962	Std. .010 .020 .030	498584 498585 498586 498587	-	-	-	-	691794 EX 691804 IN	
27803S (3 used)	394891	-	-	222698S	491319S	391086S Mag 291675S PTO	394959 394960 394961 394962	Std. .010 .020 .030	498584 498585 498586 498587	-	-	-	-	691794 EX (2 used) 691804 IN (2 used)	
27803S (2 used)	392329 Note D 394891 Note E	393403	392912	222698S	392989 399635 (2 used) 491307S	391086S Mag 291675S PTO	394959 394960 394961 394962	Std. .010 .020 .030	498584 498585 498586 498587	393127S	490652	392630 Note U	692188 Note C	490179	691794 EX (2 used) 691804 IN (2 used)
27803S (2 used)	392329 Note D 394891 Note E	393403	392912	222698S	399635 (2 used) 491319S	391086S Mag 291675S PTO	394959 394960 394961 394962	Std. .010 .020 .030	498584 498585 498586 498587	-	-	-	-	-	691794 EX (2 used) 691804 IN (2 used)
820150	-	-	-	-	825301	820055 Mag 820056 PTO	825164 825165	Std. .010	825352 825353	-	-	-	-	-	820404 EX 820403 IN
820150	820037	-	-	-	825200	820055 Mag 820056 PTO	825091 825092	Std. .010	825038 825018	-	-	-	-	-	820114 EX 820115 IN
820150	820037	-	-	-	825301	820055 Mag 820056 PTO	825091 825092	Std. .010	825308 825018	-	-	-	-	-	820114 EX 820115 IN
690971	691060	-	-	222698S	696226	391086S Mag 690947 PTO	694004 694006 694008 694010	Std. .010 .020 .030	694003 694005 694007 694009	-	-	-	-	-	499596 EX 499597 IN
27803S	394891	-	-	222698S	491319S	391086S Mag 291675S PTO	394959 394960 394961 394962	Std. .010 .020 .030	498584 498585 498586 498587	-	-	-	-	-	691794 EX (2 used) 691804 IN (2 used)



13-48 GENUINE PARTS QUICK REFERENCE

 Engine Model Series	AIR FILTER		FUEL FILTER/OIL FILTER		CARBURETOR				CONN. ROD ASSY.	FUEL TANK CAP	GASKETS				
	Foam	 Cartridge Pre-Cleaner	 Fuel Filter	 Oil Filter	 Dia-phragm	 Float Valve	 Needle Valve	 Over-haul/ Repair Kit	 Rod Assy.	 Tank Cap	 Air Cleaner	 Carb. to Cyl-inder	 Cylin-der Head	 Oil Sump/ Cover	 Set
461700	-	394019S 272490S	394358S	492932S	691873 693488	394682	-	693503	498314 498541	-	690273	692219 692278	271867S 271868S	271188 .005 271189 .009 692292 .015	495868
522400	-	820263 -	820311	820314	-	-	-	-	825171	-	-	820407	820621	820137	825315
580400	-	820263 -	692983	491056 820314	-	820486	825241	825238	825033	-	-	820087 820160	820648	820137	825378
582400	-	820263 -	820311	820314	-	-	-	-	825171	-	-	820407	820660	820137	825380
583400	-	820263 -	-	491056 820314	-	820506	825374	825258	825033	-	820385	820087	820648	820137	825378
587400	-	820263 -	692983	491056 820314	-	820506	825374	825441	825033	-	-	820087 820385	820648	820137	825378

GENUINE PARTS QUICK REFERENCE 13-49

GAS-KETS	IGNITION				MUFFLER	OIL SEALS	PISTON RINGS & PISTON ASSY.			REWIND STARTER					VALVES	
	Valve Cover	Armature	Breaker Assy.	Condenser			Fly-wheel Key	Muffler Assy.	Oil Seals	Ring Set	Piston Assy.	Clutch	Grip	Pulley	Rope	Spring
27803S	394891	-	-	222698S	-	391086S Mag 291675S PTO	499184 499185 499186 499187	Std. .010 .020 .030	498584 498585 498586 498587	-	-	-	-	-	691794 EX 691302 IN	
820150	-	-	-	-	825301	820055 Mag 820056 PTO	825164 825165	Std. .010	825311 825312	-	-	-	-	-	820404 EX 820403 IN	
820150	820037	-	-	-	825301	820055 Mag 820056 PTO	825036 825034	Std. .010	825203 825204	-	-	-	-	-	820114 EX 820115 IN	
820150	-	-	-	-	825301	820055 Mag 820056 PTO	825187 825188	Std. .010	825354 825355	-	-	-	-	-	820114 EX 820115 IN	
820150	820037	-	-	-	-	820055 Mag 820056 PTO	825036 825034	Std. .010	825203 825204	-	-	-	-	-	820114 EX 820115 IN	
820150	820037	-	-	-	825301	820055 Mag 820056 PTO	825036 825034	Std. .010	825203 825204	-	-	-	-	-	820114 EX 820115 IN	



REFERENCE NOTES

- A** – For foam air filter assembly.
- B** – For dual element air filter assembly.
- C** – Or use bulk rope and cut to length.

Part No.	Maximum Length	No.	Spool Part No.	500' Spool
66734	48-5/8" (1.2 m)	4	390619	693191
692188	63" (1.6 m)	5-1/2	390621	693193
695002	99" (2.5 m)	5-1/2	390621	693193
280399S	99" (2.5 m)	4	390619	693191
280406S	82" (2.1 m)	4	390619	693191
490876	82" (2.1 m)	4	390619	693191

- D** – For breaker point ignition.
- E** – For Magnetron® electronic ignition.
- F** – Use 291691 before code 85120500.
- G** – Use 230005 before code 85120500.
- H** – Use 260443 before code 90051300.
- I** –

NOTE:

- 1). Refer to IPL for a view of selections
- 2). Check IPL for Code Date coverage
- 3). Supplied with pulley
- 4). Supplied by OEM
- N). Not available for this Model Series

Carburetor I.D. LMS No.	Needle Valve Part No.	Carburetor Overhaul Kit Part No.
1	398157	494349
2	398157	494349
3	493765	494349
4	493765	494349
5	493765	494349
7	493765	494349
10	493765	494349
11	493765	498260
12	493765	498260
13	492500	498260
14	492500	498260
15	492500	498260



REFERENCE NOTES (Cont'd)

- | | | | | | | | | | | | |
|---|------------|------|--------|------------|--------|------------|--------|------------|--------|--------|--|
| <p>J – Use before code 90042900.
Use 494248 after code 90042800.</p> <p>K – Use 262581 after code 90051500.</p> <p>L – Not used on pulsa prime carburetor.</p> <p>M – Use 390066 for vertical pull starter.</p> <p>NX – Use 299948 for vertical pull starter. Includes #4 rope – 80" (2 m) length.</p> <p>O – Use 393152 for vertical pull starter.</p> <p>P – Use 802538 for Mikuni carburetor.</p> <p>Q – Use 802513 for Mikuni carburetor.</p> <p>R – For 50:1 & 32:1 mixture marking, use 800006</p> <p>S – Use 495770 for pulsa prime carburetor.</p> <p>T – For pulsa prime carburetor only.</p> <p>U – Includes 692188 rope – 63" (1.6 m) length, #5-1/2.</p> <p>V – Use 494349 for LMS-19 carburetor.</p> <p>W – Before date code 85042200 use:</p> <table border="0" style="margin-left: 40px;"> <tr><td>393835</td><td>Std.</td></tr> <tr><td>393836</td><td>.010" O.S.</td></tr> <tr><td>393837</td><td>.020" O.S.</td></tr> <tr><td>393838</td><td>.030" O.S.</td></tr> <tr><td>299742</td><td>Chrome</td></tr> </table> <p>X – Use 494191 before code 90051400.</p> <p>Y – Use 393960 before code 85111200.</p> <p>Z – Use 394010 before code 85111200.</p> <p>AA – 394681 uses viton rubber seat. Use 394682 if brass seat equipped. Use 394683 if brass seat/fuel pump equipped.</p> <p>BB – Use 394693 before code 84100800.</p> | 393835 | Std. | 393836 | .010" O.S. | 393837 | .020" O.S. | 393838 | .030" O.S. | 299742 | Chrome | <p>CC – Use 396795 before code 83052000.</p> <p>DD – Use 391071 before code 81060200.</p> <p>EE – Use 396795 before code 83051600.</p> <p>FF – Use 261503 before code 89021000.</p> <p>GG – Use 394434 before code 81082500.</p> <p>HH – Use 391071 before code 81101200.</p> <p>II – Use 394434 before code 81062410.</p> <p>JJ – Use 394436 before code 81062410.</p> <p>KK – Use 391071 before code 81060211.</p> <p>LL – Use 398811 before code 88090600.</p> <p>MM – Use 491538 on type numbers above 1000.</p> <p>NN – Use 271423 with anti-after fire system.</p> <p>OO – Use 394683 on type numbers above 1100.</p> <p>PP – Use 491538 on type numbers above 1100.</p> <p>QQ – Use 394683 on type numbers above 1200.</p> <p>RR – Use 491538 on type numbers above 1200.</p> <p>SS – Use 2 each 393270 on model series 400447, 400777, 402442, 402445, 402447, 402777 and 404777.</p> <p>TT – Use 2 each 394306 on model series 422442, 422447 and 422777.</p> <p>UU – Use 691877 (.015"), 272127 (.005"), 272128 (.009") on model series 400447, 402442, 402445, 402447, 422442 and 422447.</p> <p>VV – Use 391071 before code 81090910.</p> <p>WW – Use 495868 for pressure lubrication equipped engines.</p> |
| 393835 | Std. | | | | | | | | | | |
| 393836 | .010" O.S. | | | | | | | | | | |
| 393837 | .020" O.S. | | | | | | | | | | |
| 393838 | .030" O.S. | | | | | | | | | | |
| 299742 | Chrome | | | | | | | | | | |

BRIGGS & STRATTON CORPORATION

AUTHORIZED CENTRAL SALES & SERVICE DISTRIBUTORS

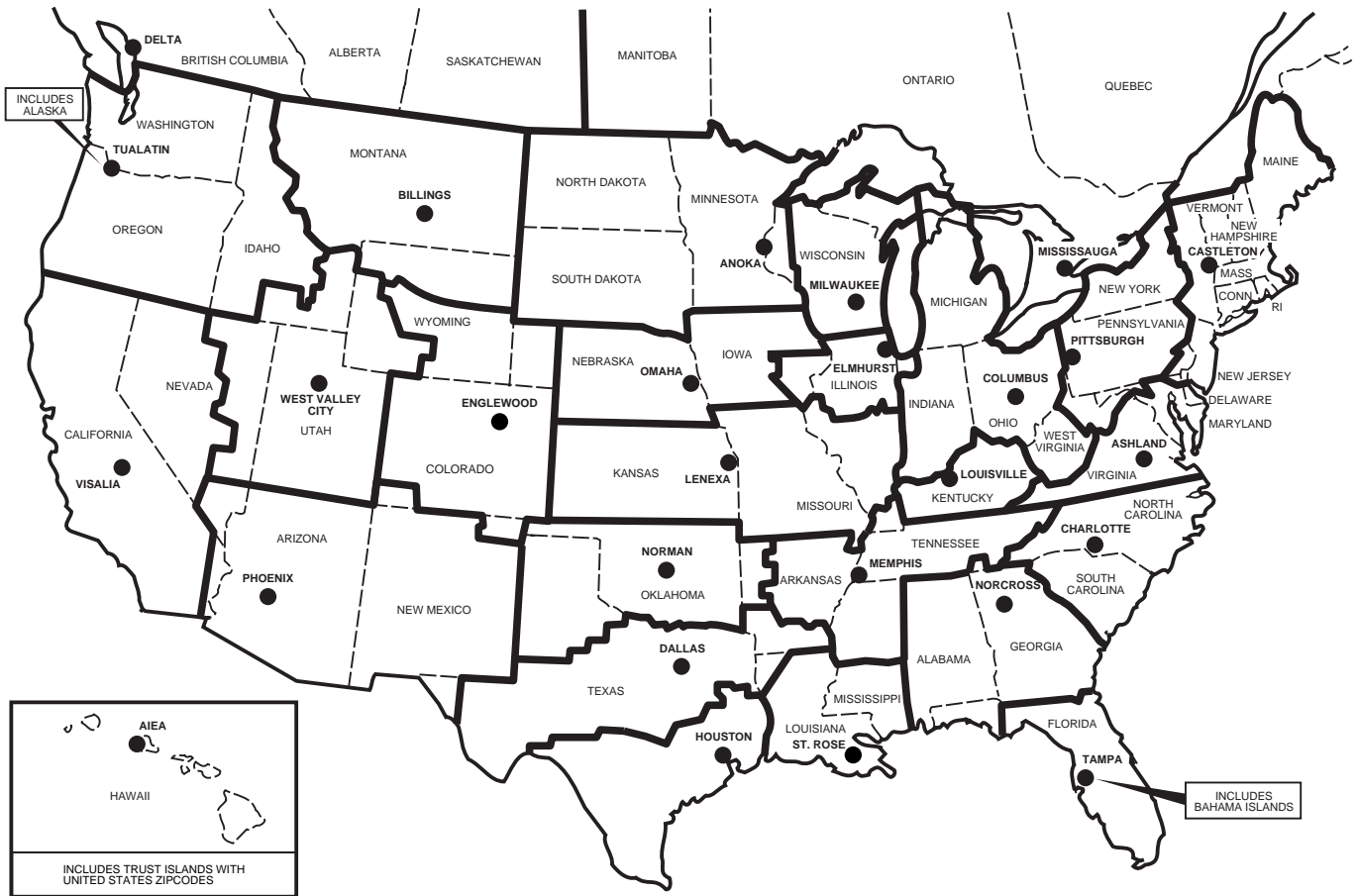

Aiea	HI	96701	Small Engine Clinic, Inc.	98-019 Kam Highway	Chau Ly	808-488-0711
Anoka	MN	55303	Wisconsin Magneto, Inc.	800 McKinley Street	Joseph Whalen	763-323-7477
Ashland	VA	23005	RBI Corporation	10201 Cedar Ridge Drive	Richard Lachine	804-550-2210
Billings	MT	59101	Original Equipment, Inc.	905 Second Avenue North	Tom Converse	406-245-3081
Castleton	NY	12033	Atlantic Power, Inc.	20 Empire State Blvd.	Darold Dunham	800-456-5692
Charlotte	NC	28216	Preferred Power, Inc.	6509-A Northpark Blvd.	Scott Harrison	704-598-1010
Columbus	OH	43228	Central Power Systems	2555 International Street	John DeNiro	614-876-3533
Dallas	TX	75207	Grayson Company, Inc.	1234 Motor Street	Steve DeWitt	214-630-3272
Elmhurst	IL	60126	Midwest Engine Warehouse	515 Romans Road	Scott Ferguson	630-833-1200
Englewood	CO	80110	Pacific Power Equipment Company	3141 S. Platte River Drive	Mike Roseboom	720-833-2900
Houston	TX	77040	Engine Warehouse, Inc.	7415 Empire Central Drive	Robert Graham	713-937-4000
Lenexa	KS	66219	Diamond Engine Sales West	15500 West 109 Street	Steve White	913-888-8828
Louisville	KY	40299	Commonwealth Engine, Inc.	11421 Electron Drive	John Clements	502-263-7026
Memphis	TN	38116	Engine Power Distributors	3250 Millbranch Road	Ken Broom	901-345-0300
Milwaukee	WI	53209	Wisconsin Magneto, Inc.	4727 N. Teutonia Avenue	Mark Polzin	414-445-2800
Norcross	GA	30093	SEDCO, Inc.	4305 Steve Reynolds Blvd.	Frank Manno	770-925-4706
Norman	OK	73069	Engine Warehouse, Inc.	2701 Venture Drive	Charles Francis	405-364-6868
Omaha	NE	68138	Midwest Engine Warehouse of Omaha	10606 S. 144th St.	Steve Potthoff	402-891-1700
Phoenix	AZ	85009	Power Equipment Company	7 North 43rd Avenue	Diane Bickford	602-272-3936
Pittsburgh	PA	15233	Three Rivers Engine Distributors, Inc.	1411 Beaver Avenue	John Gable	412-321-4111
St. Rose	LA	70087	Grayson Company Kenner	120 Pintail Street	Bob McCary	504-465-9222
Tampa	FL	33610	Central Power Systems of Florida	4751 Oak Fair Boulevard	Rick Dalton	813-626-5447
Tualatin	OR	97062	Brown & Wiser, Inc.	9991 S. W. Avery Street	Mark Adams	503-692-0330
Visalia	CA	93291	Power Equipment Company	7101 W. Doe Avenue	Diane Bickford	559-651-1150
West Valley City	UT		84120 Frank Edwards Company	3626 Parkway Blvd.	Kevin Day	801-736-8060
CANADA						
Mississauga (Toronto)			ON L5T 2J3 Briggs & Stratton Canada Inc.	301 Ambassador Drive	Neil Sheidow	905-795-2632
Delta (Vancouver)	BC		V3M 6R9 Briggs & Stratton Canada Inc.	300 - 1628 Derwent Way	Ken Laurie	604-520-1294



BRIGGS & STRATTON CATALOG IMPROVEMENT FORM

In an effort to continually improve our literature and catalogs, we would appreciate a few moments of your time to complete this form and provide us with your suggestions and comments. When finished, fold it according to the directions on the back side and mail it back to us. We've provided the postage for you.

• Do you find this catalog easy to use? Yes_____ No_____

• What changes or additions would you like to see?

Please list any additional parts, tools or accessories you would like featured in this catalog.

<u>Part Number</u>	<u>Description</u>	<u>Part Number</u>	<u>Description</u>
_____	_____	_____	_____
_____	_____	_____	_____
_____	_____	_____	_____
_____	_____	_____	_____
_____	_____	_____	_____

Are you currently an Authorized Briggs & Stratton Dealer? Yes_____ No_____

If you are not an Authorized Briggs & Stratton Dealer, are you interested in becoming one? Yes_____ No_____

If yes, would you like to have a representative call you? Yes_____ No_____

Name_____

Address_____

City/State/Zip_____

Phone ()_____



fold

Place
Stamp
Here

BRIGGS & STRATTON CORPORATION
DISTRIBUTION SALES & CUSTOMER SUPPORT
ATTN: SALES & MARKETING
P O BOX 702
MILWAUKEE WI 53201-0702

fold



HOW TO READ BRIGGS & STRATTON MODEL NUMBERS

This handy chart explains the unique Briggs & Stratton numerical model designation system. It is possible to determine most of the important mechanical features of the engine by merely knowing the model number. Here is how it works:

- A. The first one or two digits indicate the CUBIC INCH DISPLACEMENT.
- B. The first digit after the displacement indicates BASIC DESIGN SERIES, relating to cylinder construction, ignition, general configuration, etc.
- C. The second digit after the displacement indicates POSITION OF CRANKSHAFT and TYPE OF CARBURETOR.
- D. The third digit after the displacement indicates TYPE OF BEARINGS and whether or not the engine is equipped with REDUCTION GEAR or AUXILIARY DRIVE.
- E. The last digit indicates the TYPE OF STARTER.

BRIGGS & STRATTON MODEL NUMBERING SYSTEM

<u>A</u>	<u>B</u>	<u>C</u>	<u>D</u>	<u>E</u>
<u>CUBIC INCH DISPLACEMENT</u>	<u>BASIC DESIGN SERIES</u>	<u>CRANKSHAFT, CARBURETOR, GOVERNOR</u>	<u>PTO BEARING, REDUCTION GEAR, AUXILIARY DRIVE, LUBRICATION</u>	<u>TYPE OF STARTER</u>
6	0	0 - Horizontal Shaft	0 - Plain Bearing/DU	0 - Without Starter
8	1	Diaphragm Carburetor	Non-Flange Mount	1 - Rope Starter
9	2	Pneumatic Governor	1 - Plain Bearing	2 - Rewind Starter
10	3	1 - Horizontal Shaft	Flange Mounting	3 - Electric Starter Only
11	4	Vacu-Jet Carburetor	2 - Sleeve Bearing	110 or 230 Volt Gear Drive
12	5	Pneumatic Governor	Flange Mounting	4 - Electric Starter/110 or 230 Volt Gear Drive with Alternator
13	6	2 - Horizontal Shaft	Splash Lube	5 - Electric Starter Only
16	7	Pulsa-Jet Carburetor	3 - Ball Bearing	12 or 24 Volt Gear Drive
18	8	Pneumatic or Mechanical Governor	Flange Mounting	5 - Electric Starter Only
19	9	3 - Horizontal Shaft	Splash Lube	12 or 24 Volt Gear Drive
20	A to Z	Flo-Jet Carburetor	4 - Ball Bearing	6 - Alternator Only
21		Pneumatic Governor	Flange Mounting	7 - Electric Starter
22		4 - Horizontal Shaft	Pressure Lubrication on Horizontal Shaft	12 or 24 Volt Gear Drive with Alternator
23		Flo-Jet Carburetor	5 - Plain Bearing	8 - Vertical Pull Starter or Side Pull Starter
24		Mechanical Governor	Gear Reduction	9 - Mechanical Starter
25		5 - Vertical Shaft	(6 to 1) CW Rotation	A - Electric Starter
28		Vacu-Jet Carburetor	Flange Mounting	12 or 24 Volt Gear Drive with Alternator and Inverter
29		Pneumatic or Mechanical Governor	6 - Plain Bearing	
30		6 - Vertical Shaft	Gear Reduction	
31		7 - Vertical Shaft	(6 to 1) CCW Rotation	
32		Flo-Jet Carburetor	Flange Mounting on Vertical Shaft	
35		Pneumatic or Mechanical Governor	8 - Plain Bearing	
38		8 - Vertical Shaft	Auxiliary Drive (PTO)	
40		Flo-Jet Carburetor	Perpendicular to Crankshaft	
42		Pneumatic or Mechanical Governor	9 - Plain Bearing	
43		9 - Vertical Shaft	Auxiliary Drive	
44		Pulsa-Jet Carburetor	Parallel to Crankshaft	
46		Pneumatic or Mechanical Governor		
52		A to G - Horizontal Shaft		
58		H to Z - Vertical Shaft		

EXAMPLE - To identify Model 303447:

<u>30</u>	<u>3</u>	<u>4</u>	<u>4</u>	<u>7</u>
30 Cubic Inch	Design Series 3	Horizontal Shaft - Flo-Jet Carburetor Mechanical Governor	Ball Bearing Flange Mounting Pressure Lubrication on Horizontal Shaft	Electric Starter 12 or 24 Volt Gear Drive with Alternator

