

**130400 to 130499**

**SERVICE ENGINE**  **SALES MANUAL**

**MODEL 130400 SERIES ENGINES REPLACED WITH  
 STANDARD SERVICE ENGINES**

In most cases, the Original Type numbers shown may be replaced by a Service Type Number without making any changes. Necessary changes of engine parts such as crankshafts, reduction parts, blower housings, etc., are noted. Other differences, such as mufflers, elbows, deflectors, etc., are not listed but are very important for safety and engine performance. Be sure the exhaust system on the replacement engine duplicates the system originally selected by the equipment manufacturer. Parts that are suitable for additional use should be transferred. Before making any conversion, check the data shown in the column labeled "REMOVE, ADD and NOTE." See if the changes, which are shown, are actually necessary on the application in question. Often a standard service engine will be a WORKABLE replacement without converting to such things as a special fuel tank or starter position.

If the crankshaft number does not appear in the "Original Engine" column, consult the Illustrated Parts List for the correct service replacement crankshaft number.

**Engine Replacement Notes:**

- NOTE 15:** For all Go-Karts use only a Model 136200 series engine as a replacement, regardless of the original Model.
- NOTE 25:** If the replacement engine supersedes to or is a Model 120000 series engine, refer to the illustrations located after the conversion data for this model series. The overall dimensions that differ, are shown in the illustrations. If after making a visual inspection and it is determined the Model 120000 series engine cannot be used because of equipment interference, the original engine should be repaired with individual parts.

**Short Block Notes:**

The SHORT BLOCK part number shown, is the assembly which can be used to rebuild the Original Type Number. If a letter appears after the short block number, it indicates the short block must be modified. The change denoted by each letter is as follows:

**130400 to 130499**

Original Engine			Make From		Remove		Add		Note	Change to Type	Trim	RPM	Short Block	
Type	Model	Crank	Model	Type #	Qty	Part #	Qty	Part #					Part #	Notes
0105	130412	397104	No Replacement		Repair With Individual Parts.				15		All	3750	496821	
0106	130412	494035	No Replacement		Repair With Individual Parts.				15		All	3750	496821	
4001	130412	494035	No Replacement		Repair With Individual Parts.				15		All	3750	496821	
5001	130432	397090	121432	0033					15 25		All	3750	694196	
5002	130432	397090	121432	0033					15 25		All	3750	694196	
5003	130432	397090	121332	0033					15 25		All	3750	694196	
5004	130412	493980	121332	0033					15 25		All	3750	694196	

**MODEL 130400**

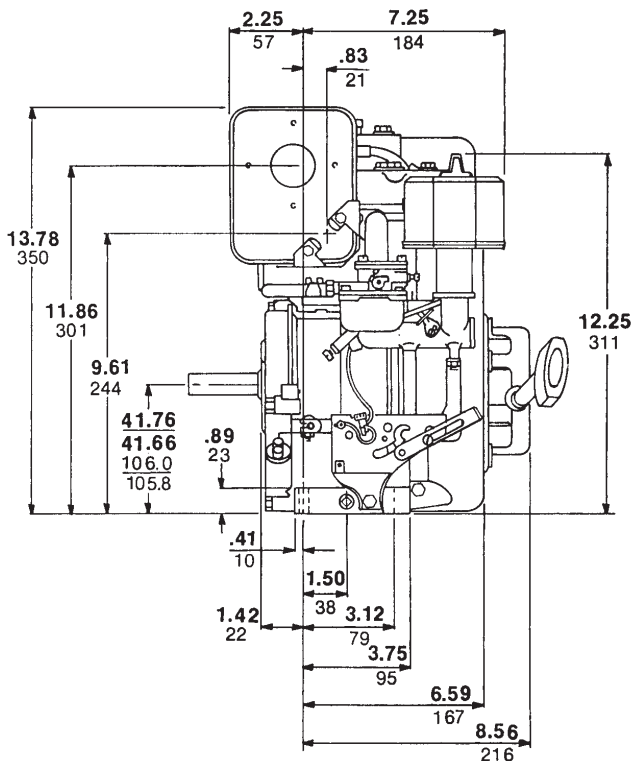
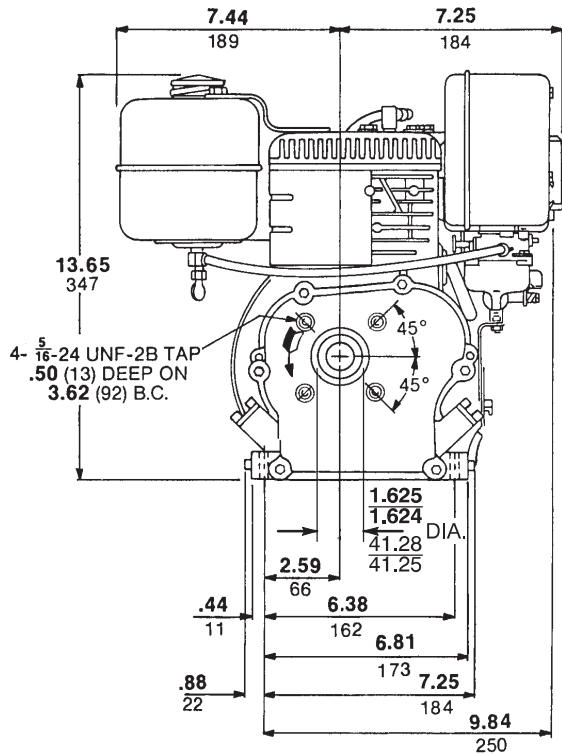

**MODEL 120000**

