



FOREWORD

This Arctic Cat Service Manual contains service, maintenance, and troubleshooting information for the 2011 Arctic Cat Prowler HDX. The complete manual is designed to aid service personnel in service-oriented applications.

This manual is divided into sections. Each section covers a specific vehicle component or system and, in addition to the standard service procedures, includes disassembling, inspecting, and assembling instructions. When using this manual as a guide, the technician should use discretion as to how much disassembly is needed to correct any given condition.

The service technician should become familiar with the operation and construction of each component or system by carefully studying this manual. This manual will assist the service technician in becoming more aware of and efficient with servicing procedures. Such efficiency not only helps build consumer confidence but also saves time and labor.

All Arctic Cat publications and decals display the words Warning, Caution, Note, and At This Point to emphasize important information. The symbol  **WARNING** identifies personal safety-related information. Be sure to follow the directive because it deals with the possibility of serious personal injury or even death. A **CAUTION** identifies unsafe practices which may result in vehicle-related damage. Follow the directive because it deals with the possibility of damaging part or parts of the vehicle. The symbol  **NOTE:** identifies supplementary information worthy of particular attention. The symbol  **AT THIS POINT** directs the technician to certain and specific procedures to promote efficiency and to improve clarity.

At the time of publication, all information, photographs, and illustrations were technically correct. Some photographs used in this manual are used for clarity purposes only and are not designed to depict actual conditions. Because Arctic Cat Inc. constantly refines and improves its products, no retroactive obligation is incurred.

All materials and specifications are subject to change without notice.

Keep this manual accessible in the shop area for reference.

**Product Service and
Warranty Department
Arctic Cat Inc.**

TABLE OF CONTENTS

Note: To navigate through this manual, use the PAGE UP/PAGE DOWN buttons on the keyboard, click on the Table of Contents bookmarks on the left side of the screen, or click the blue text below. To return to this page, click the Manual Table of Contents button at the bottom of each page.

1. General Information/Specifications	1
2. Periodic Maintenance/Tune-Up	2
3. Engine/Transmission	3
4. Fuel/Lubrication/Cooling	4
5. Electrical System	5
6. Drive System	6
7. Suspension	7
8. Steering/Frame	8
9. Controls/Indicators	9

SECTION 1 - GENERAL INFORMATION

TABLE OF CONTENTS

General Specifications	1-2
Torque Specifications	1-2
Torque Conversions (ft-lb/N-m)	1-3
Tightening Torque (General Bolts)	1-3
Break-In Procedure	1-4
Gasoline - Oil - Lubricant	1-4
Genuine Parts	1-5
Preparation For Storage	1-5
Preparation After Storage.....	1-5

General Specifications

CHASSIS	
Dry Weight (approx)	618 kg (1363 lb)
Length (overall)	327.6 cm (129 in.)
Height (overall)	193.3 cm (76.5 in.)
Width (overall)	153 cm (60.25 in.)
Suspension Travel	25.4 cm (10 in.)
Brake Type	Hydraulic
Tire Size	(front) 26 x 10R-14 (rear) 26 x 12R-14
Tire Inflation Pressure	1.41 kg/cm ² (20 psi)
MISCELLANY	
Gas Tank Capacity	31 L (8.2 U.S. gal.)
Coolant Capacity	2.9 L (3.0 U.S. qt)
Front Differential Capacity	275 ml (9.3 fl oz)*
Rear Drive Capacity	250 ml (8.5 fl oz)*
Engine Oil Capacity	2.5 L (2.6 U.S. qt) - Overhaul 1.9 L (2.0 U.S. qt) - Change
Gasoline (recommended)	87 Octane Regular Unleaded
Engine Oil (recommended)	Arctic Cat ACX All Weather Synthetic
Front Differential/Rear Drive Lubricant	SAE Approved 80W-90 Hypoid
Belt Width	35.0 mm (1.38 in.)
Brake Fluid	DOT 4
Taillight/Brakelight	12V/8W/27W
Headlight	12V/27W (4)

Specifications subject to change without notice.

* Visible at plug threads.

Torque Specifications

NOTE: Torque specifications have the following tolerances:

Torque (ft-lb)	Tolerance
0-15	±20%
16-39	±15%
40+	±10%

EXHAUST COMPONENTS			
Part	Part Bolted To	Torque	
		ft-lb	N-m
Exhaust Pipe	Cylinder Head	20	27
Spark Arrester	Muffler	48 in.-lb	5

ELECTRICAL COMPONENTS			
Part	Part Bolted To	Torque	
		ft-lb	N-m
Coil*	Frame	8	11
Ground Wire	Engine	8	11

CHASSIS/ROPS ASSEMBLY			
Part	Part Bolted To	Torque	
		ft-lb	N-m
Shift Axle Support	Frame	48 in.-lb	5
Front/Rear ROPS Tube	Arm Rest/Steering Post Support	20	27
Top ROPS Support	Front/Rear ROPS Tubes	8	11
Rear ROPS Tube	Lower ROPS Support	8	11
Shift Cable	Shift Axle Arm	8	11
Shift Cable Mounting/Adjuster	Shift Cable	20	27

STEERING COMPONENTS			
Part	Part Bolted To	Torque	
		ft-lb	N-m
Steering Wheel**	Steering Wheel Shaft	25	34
Steering Wheel Shaft***	Intermediate Shaft (Upper)	36	49
Intermediate Shaft (Lower)***	Steering Pinion Shaft	36	49
Rack and Pinion Assembly	Frame	35	48
Tie Rod	Rack	37	50
Tie Rod End**	Knuckle	30	41
Jam Nut	Tie Rod End	10	14
Steering Shaft Coupler	EPS Input Shaft	11	15
EPS Cradle Bracket	Frame	20	27
EPS Assembly	Frame	35	48
EPS Assembly	Rack Coupler	11	15
Intermediate Shaft Coupler	Intermediate Shaft	31	42
Steering Shaft Housing (6 mm)	Frame	8	11
Steering Shaft Housing (8 mm)	Frame	20	27
SUSPENSION COMPONENTS (Front)			
A-Arm	Frame	33	45
Knuckle	Ball Joint	35	48
Shock Absorber	Frame/Upper A-Arm	33	45
Knuckle	A-Arm	35	48
SUSPENSION COMPONENTS (Rear)			
Sway Bar Bracket	Frame	33	45
A-Arm	Frame	33	45
Shock Absorber (Lower)	Lower A-Arm	20	27
Shock Absorber (Upper)	Frame	33	45
Knuckle	A-Arm	35	48
Cargo Box Hinge	Cargo Box Frame	20	27
Side Panel/Spacer	Cargo Box Frame	25	34
Tilt Pivot Bushing	Cargo Box Frame	15	20
Latch Striker	Cargo Box Liner	60 in.-lb	7
BRAKE COMPONENTS			
Brake Disc**	Hub	15	20
Brake Hose	Caliper	20	27
Brake Hose	Master Cylinder	20	27
Master Cylinder	Frame	25	34
Caliper Holder****	Knuckle	20	27
Driveline	Rear Drive Input Flange	20	27

* w/Blue Loctite #243

*** w/Green Loctite #270

** w/Red Loctite #271

**** w/“Patch-Lock”

DRIVE TRAIN COMPONENTS			
Part	Part Bolted To	Torque	
		ft-lb	N-m
Rear Differential/Gear Case	Frame	38	48
Drive Coupler (Front)	Front Drive Flange	40	54
Front Engine Mounting Bracket	Frame	45	61
Rear Engine Mounting Bracket	Frame	45	61
Engine Mounting Through-Bolt	Frame	40	54
Front Differential	Frame/Differential Bracket	38	52
Rear Output Flange	Rear Driven Flange	40	54
Input Shaft Assembly	Gear Case Housing	23	31
Pinion Housing	Differential Housing	23	31
Secondary Shaft Bearing Housing	Crankcase	28	38
Rear Cradle	Frame	25	34
Driveshaft (Front/Rear)	Engine	20	27
Shift Cable Bracket	Engine	8	11
Front Input Drive Flange	Front Drive Yoke Flange	20	27
Differential Housing Cover***	Differential Housing	23	31
Drive Bevel Gear Nut***	Shaft	87	118
Lock Collar	Differential Housing	125	170
Hub Nut	Front/Rear Shaft/Axle (min)	200	272
Oil Drain Plug	Front Differential - Rear Drive	45 in.-lb	5
Oil Fill Plug	Front Differential - Rear Drive	16	22
Oil Drain Plug	Engine	16	22
Wheel	Hub	80	108
ENGINE/TRANSMISSION			
Clutch Shoe**	Crankshaft	221	300
Clutch Cover/Housing Assembly	Crankcase	8	11
Crankcase Half (6 mm)	Crankcase Half	10	14
Crankcase Half (8 mm)	Crankcase Half	20	27
Cylinder Head (Cap Screw)	Crankcase	40	54
Cylinder Head Nut (6 mm)	Cylinder	8	11
Cylinder Head Nut (8 mm)	Cylinder	18	24
Valve Cover	Cylinder Head	8.5	11.5
Driven Pulley Nut	Driveshaft	80	109
Movable Drive Face Nut**	Driveshaft	165	224
Ground Wire	Engine	8	11
Magneto Cover	Crankcase	8	11
Tappet Cover	Valve Cover	9	12
Crankshaft Spacer	Crankshaft	28	38
Oil Pump Cover**	Crankcase	8	11
Oil Pump Drive Gear**	Crank Balancer Shaft	62	84
Output Shaft Flange Nut	Output Shaft**	62	84
Outer Magneto Cover	Magneto Cover	8	11
Magneto Rotor Nut**	Crankshaft	105	143
Cam Sprocket**	Camshaft	11	15
Speed Sensor Housing	Crankcase	8	11
V-Belt Cover	Crankcase	8	11
Output Yoke Nut	Secondary Driven Output Shaft	74	100
Output Shaft Flange Yoke/Nut	Output Shaft**	59	80
Secondary Shaft Bearing Housing	Crankcase Half	28	38
Stator Coil*	Magneto Cover	8.5	11.5
Intake Boot Clamp	Intake Boot	30 in.-lb	3.4

* w/Blue Loctite #243

** w/Red Loctite #271



*** w/Green Loctite #270

Torque Conversions (ft-lb/N-m)

ft-lb	N-m	ft-lb	N-m	ft-lb	N-m	ft-lb	N-m
1	1.4	26	35.4	51	69.4	76	103.4
2	2.7	27	36.7	52	70.7	77	104.7
3	4.1	28	38.1	53	72.1	78	106.1
4	5.4	29	39.4	54	73.4	79	107.4
5	6.8	30	40.8	55	74.8	80	108.8
6	8.2	31	42.2	56	76.2	81	110.2
7	9.5	32	43.5	57	77.5	82	111.5
8	10.9	33	44.9	58	78.9	83	112.9
9	12.2	34	46.2	59	80.2	84	114.2
10	13.6	35	47.6	60	81.6	85	115.6
11	15	36	49	61	83	86	117
12	16.3	37	50.3	62	84.3	87	118.3
13	17.7	38	51.7	63	85.7	88	119.7
14	19	39	53	64	87	89	121
15	20.4	40	54.4	65	88.4	90	122.4
16	21.8	41	55.8	66	89.8	91	123.8
17	23.1	42	57.1	67	91.1	92	125.1
18	24.5	43	58.5	68	92.5	93	126.5
19	25.8	44	59.8	69	93.8	94	127.8
20	27.2	45	61.2	70	95.2	95	129.2
21	28.6	46	62.6	71	96.6	96	130.6
22	29.9	47	63.9	72	97.9	97	131.9
23	31.3	48	65.3	73	99.3	98	133.3
24	32.6	49	66.6	74	100.6	99	134.6
25	34	50	68	75	102	100	136

1

Tightening Torque (General Bolts)

Type of Bolt	Thread Diameter A (mm)	Tightening Torque
(Conventional or 4 Marked Bolt) 	5	12-36 in.-lb
	6	36-60 in.-lb
	8	7-11 ft-lb
	10	16-25 ft-lb
(7 Marked Bolt) 	5	24-48 in.-lb
	6	6-8 ft-lb
	8	13-20 ft-lb
	10	29-43 ft-lb

Break-In Procedure

A new vehicle and an overhauled engine require a “break-in” period. The first 10 hours (or 200 miles) are most critical to the life of this vehicle. Proper operation during this break-in period will help assure maximum life and performance from the vehicle.

During the first 10 hours (or 200 miles) of operation, always use less than 1/2 throttle. Varying the engine RPM during the break-in period allows the components to “load” (aiding the mating process) and then “unload” (allowing components to cool). Although it is essential to place some stress on the engine components during break-in, care should be taken not to overload the engine too often. Do not pull a trailer or carry heavy loads during the 10-hour break-in period.

When the engine starts, allow it to warm up properly. Idle the engine several minutes until the engine has reached normal operating temperature. Do not idle the engine for excessively long periods of time.

During the break-in period, a maximum of 1/2 throttle is recommended; however, brief full-throttle accelerations and variations in driving speeds contribute to good engine break-in.

After the completion of the break-in period, the engine oil and oil filter should be changed. Other maintenance after break-in should include checking of all prescribed adjustments and tightening of all fasteners (see Periodic Maintenance Chart in Section 2).

Gasoline - Oil - Lubricant

RECOMMENDED GASOLINE

The recommended gasoline to use is 87 minimum octane regular unleaded. In many areas, oxygenates (either ethanol or MTBE) are added to the gasoline. Oxygenated gasolines containing up to 10% ethanol, 5% methane, or 5% MTBE are acceptable gasolines.

When using ethanol blended gasoline, it is not necessary to add a gasoline antifreeze since ethanol will prevent the accumulation of moisture in the fuel system.

CAUTION

Do not use white gas. Only Arctic Cat approved gasoline additives should be used.

RECOMMENDED ENGINE/ TRANSMISSION OIL

CAUTION

Any oil used in place of the recommended oil could cause serious engine damage. Do not use oils which contain graphite or molybdenum additives. These oils can adversely affect clutch operation. Also, not recommended are racing, vegetable, non-detergent, and castor-based oils.

The recommended oil to use is Arctic Cat ACX All Weather synthetic engine oil, which has been specifically formulated for use in this Arctic Cat engine. Although Arctic Cat ACX All Weather synthetic engine oil is the only oil recommended for use in this engine, use of any API certified SM 5W-50 oil is acceptable.

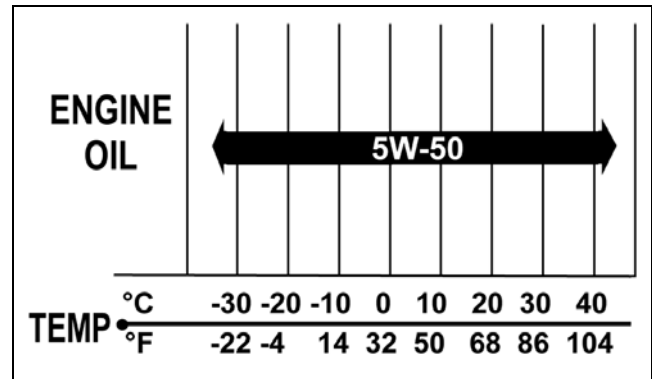

OILCHART1

RECOMMENDED FRONT DIFFERENTIAL/REAR DRIVE LUBRICANT

The recommended lubricant is Arctic Cat Gear Lube or an equivalent gear lube which is SAE approved 80W-90 hypoid. This lubricant meets all of the lubrication requirements of the Arctic Cat vehicle front differential and rear drive.

CAUTION

Any lubricant used in place of the recommended lubricant could cause serious front differential/rear drive damage.

FILLING GAS TANK

⚠ WARNING

Always fill the gas tank in a well-ventilated area. Never add fuel to the gas tank near any open flames or with the engine running. **DO NOT SMOKE** while filling the gas tank.

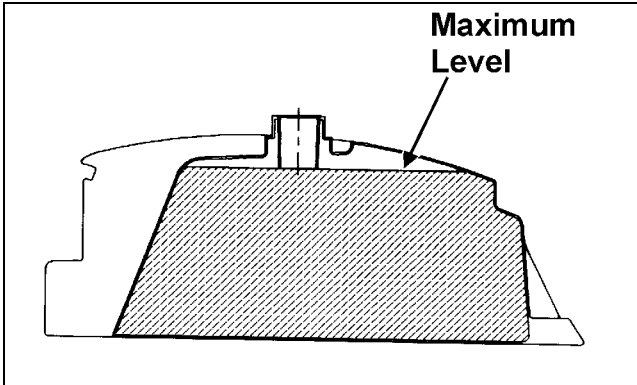

ATV0049B

Since gasoline expands as its temperature rises, the gas tank must be filled to its specified capacity only. Expansion room must be maintained in the tank particularly if the tank is filled with cold gasoline and then moved to a warm area.

⚠ WARNING

Do not overflow gasoline when filling the gas tank. A fire hazard could materialize. Always allow the engine to cool before filling the gas tank.

Tighten the gas tank cap securely after filling the tank.

⚠ WARNING

Do not over-fill the gas tank.

Genuine Parts

When replacement of parts is necessary, use only genuine Arctic Cat parts. They are precision-made to ensure high quality and correct fit. Refer to the appropriate Illustrated Parts Manual for the correct part number, quantity, and description.

Preparation For Storage

CAUTION

Prior to storing the vehicle, it must be properly serviced to prevent rusting and component deterioration.

1. Clean the seat cushion (cover and base) with a damp cloth and allow it to dry.

2. Clean the vehicle thoroughly by washing dirt, oil, grass, and other foreign matter from the entire vehicle. Allow it to dry thoroughly. **DO NOT** get water into any part of the engine or air intake.
3. Either drain the gas tank or add Fuel Stabilizer to the gas in the gas tank. Remove the air filter housing cover and air filter. Start the engine and allow it to idle. Using Arctic Cat Engine Storage Preserver, rapidly inject the preserver into the air filter opening for a period of 10 to 20 seconds; then stop the engine. Install the air filter and housing cover.

CAUTION

If the interior of the air filter housing is dirty, clean the area before starting the engine.

4. Plug the exhaust hole in the exhaust system with a clean cloth.
5. Apply light oil to the plungers of the shock absorbers.
6. Tighten all nuts, bolts, cap screws, and screws. Make sure rivets holding components together are tight. Replace all loose rivets. Care must be taken that all calibrated nuts, cap screws, and bolts are tightened to specifications.
7. Fill the cooling system to the bottom of the stand pipe in the radiator neck with properly mixed coolant.
8. Disconnect the battery cables; then remove the battery, clean the battery posts and cables, and store in a clean, dry area.
9. Store the vehicle indoors in a level position.

CAUTION

Avoid storing outside in direct sunlight and avoid using a plastic cover as moisture will collect on the vehicle causing rusting.

Preparation After Storage

Taking the vehicle out of storage and correctly preparing it will assure many miles and hours of trouble-free riding.

1. Clean the vehicle thoroughly.
2. Clean the engine. Remove the cloth from the exhaust system.
3. Check all control wires and cables for signs of wear or fraying. Replace if necessary.
4. Change the engine/transmission oil and filter.
5. Check the coolant level and add properly mixed coolant as necessary.

6. Charge the battery; then install. Connect the battery cables.

CAUTION

The ignition switch must be in the OFF position prior to installing the battery or damage may occur to the ignition system.

CAUTION

Connect the positive battery cable first; then the negative.

7. Check the entire brake systems (fluid level, pads, etc.), all controls, headlights, taillight, brakelight, and headlight aim; adjust or replace as necessary.

8. Tighten all nuts, bolts, cap screws, and screws making sure all calibrated nuts, cap screws, and bolts are tightened to specifications.

9. Check tire pressure. Inflate to recommended pressure as necessary.

10. Make sure the steering moves freely and does not bind.

11. Check the spark plug. Clean or replace as necessary.

SECTION 2 - PERIODIC MAINTENANCE/TUNE-UP

TABLE OF CONTENTS

Periodic Maintenance Chart.....	2-2
Periodic Maintenance.....	2-3
Lubrication Points.....	2-3
Air Filter.....	2-3
Valve/Tappet Clearance.....	2-3
Testing Engine Compression.....	2-4
Spark Plug.....	2-5
Muffler/Spark Arrester.....	2-5
Engine/Transmission Oil - Filter.....	2-6
Front Differential - Rear Drive Lubricant.....	2-7
Driveshaft/Coupling.....	2-7
Nuts/Bolts/Cap Screws.....	2-7
Headlight/Taillight-Brakelight.....	2-7
Shift Lever.....	2-8
Hydraulic Brake System.....	2-10
Burnishing Brake Pads.....	2-11
Checking/Replacing V-Belt.....	2-11
Troubleshooting Brake System.....	2-14

Periodic Maintenance Chart

A = Adjust I = Inspect
 C = Clean L = Lubricate
 R = Replace T = Tighten

Item	Initial Service After Break-In (First Month or 100 Miles)	Every Day	Every Month or Every 100 Miles	Every 3 Months or Every 300 Miles	Every 6 Months or Every 500 Miles	Every Year or Every 1500 Miles	As Needed
Battery	I		I				C
Fuses				I			R
Air Filter/Drain Tube	I	I	C*				R
Valve/Tappet Clearance	I				I		A
Engine Compression						I	
Spark Plug	I			I	I		R (4000 Mi or 18 Mo)
Muffler/Spark Arrester					C		R
Gas Hoses	I	I					R (2 Yrs)
Throttle Cable Ends/Accelerator Pedal Pivot	I	I			C-L		A-R
Engine-Transmission Oil Level		I					A
Engine-Transmission Oil/Filter	R			R*/R**/R***			R
Oil Strainer	I				I***		C
Front Differential - Rear Drive Lubricant	I		I				R (4 Yrs)
Tires/Air Pressure	I	I					R
Steering Components	I	I		I			R
V-Belt	I				I		R
Suspension (Ball joint boots, drive axle boots front and rear, tie rods, differential and rear drive bellows)	I	I					R
Nuts/Bolts/Cap Screws	T		T				A
Ignition Timing						I	
Headlight/Taillight-Brakelight	I	I					R
Switches	I	I					R
Shift Lever					I		A-L
Gauges/Indicators	I	I					R
Frame/Welds	I		I		I		
Electrical Connections					I		C
Complete Brake System (Hydraulic)	I	I					
Brake Pads	I			I*			R
Brake Fluid	I			I			R (2 Yrs)
Brake Hoses	I			I			R (4 Yrs)
Coolant/Cooling System	I		I				R (2 Yrs)
Wheel Lug Nuts	T			T			

* Service/Inspect more frequently when operating in adverse conditions.

** When using an API certified SM 5W-50 oil.

*** When using Arctic Cat ACX All Weather synthetic oil, oil change and strainer inspection interval can be increased to every 1,000 miles or every year.

Periodic Maintenance

This section has been organized into sub-sections which show common maintenance procedures for the Arctic Cat ROV.

■NOTE: Arctic Cat recommends the use of new gaskets, lock nuts, and seals and lubricating all internal components when servicing the engine/transmission.

■NOTE: Some photographs and illustrations used in this section are used for clarity purposes only and are not designed to depict actual conditions.

■NOTE: Critical torque specifications are located in Section 1.

SPECIAL TOOLS

A number of special tools must be available to the technician when performing service procedures in this section. Refer to the current Special Tools Catalog for the appropriate tool description.

Description	p/n
Compression Tester Kit	0444-213
Oil Filter Wrench	0644-389
Timing Light	0644-296
Valve Clearance Adjuster	0444-255

■NOTE: Special tools are available from the Arctic Cat Service Parts Department.

Lubrication Points

It is advisable to lubricate certain components periodically to ensure free movement. Apply light oil to the components using the following list as reference.

- A. Accelerator Pedal Pivot/Cable Ends
- B. Brake Pedal Pivot
- C. Shift Cable

Air Filter

CAUTION

Failure to inspect the air filter frequently if the vehicle is used in dusty, wet, or muddy conditions can damage the engine.

1. Raise the cargo box; then remove any dust and debris from around the filter housing.
2. Unsnap the four spring-clip fasteners and remove the cover.



HDX050A

2

3. Fill a wash pan larger than the element with a non-flammable cleaning solvent; then dip the element in the solvent and wash it.

■NOTE: Foam Filter Cleaner and Foam Filter Oil are available from Arctic Cat.

4. Dry the element.
5. Put the element in a plastic bag; then pour in air filter oil and work the element. Reattach the filter to the filter screen.

■NOTE: Carefully squeeze excess oil from the element.

CAUTION

A torn air filter can cause damage to the vehicle engine. Dirt and dust may get inside the engine if the element is torn. Carefully examine the element for tears before and after cleaning it. Replace the element with a new one if it is torn.

6. Clean any dirt or debris from inside the filter housing. Be sure no dirt enters the throttle body.
7. Install the air filter and cover and lower the cargo box.

CHECKING AND CLEANING DRAINS

1. Inspect the “duck-bill” drain beneath the main housing for debris and for proper sealing.
2. Remove the tube drain and clean out any water, oil, or debris. Reinstall and secure with the clamp.

Valve/Tappet Clearance

To check and adjust valve/tappet clearance, use the following procedure.

■NOTE: The engine must be cold for this procedure.

■NOTE: The seat, seat back, seat base, and spark plug must be removed for this procedure.

1. Remove the spark plug and timing inspection plug; then remove the tappet covers (for more detailed information, see Section 3 - Servicing Top-Side Components).
2. Rotate the crankshaft to the TDC position on the compression stroke.

■NOTE: At this point, the rocker arms and adjuster screws must not have pressure on them.

Feeler Gauge Procedure

Using a feeler gauge, check each valve/tappet clearance. If clearance is not within specifications, loosen the jam nut and rotate the tappet adjuster screw until the clearance is within specifications. Tighten each jam nut securely after completing the adjustment.

CAUTION	
The feeler gauge must be positioned at the same angle as the valve and valve adjuster for an accurate measurement of clearance. Failure to measure the valve clearance accurately could cause valve component damage.	
VALVE/TAPPET CLEARANCE	
Intake	0.1016 mm (0.004 in.)
Exhaust	0.1524 mm (0.006 in.)

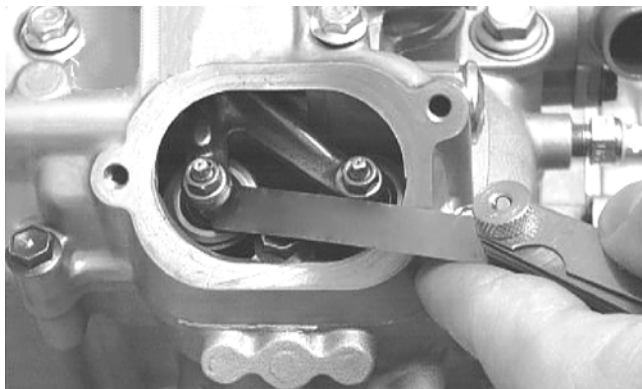

CC007D

Valve Adjuster Procedure

- A. Place the Valve Clearance Adjuster onto the jam nut securing the tappet adjuster screw; then rotate the valve adjuster dial clockwise until the end is seated in the tappet adjuster screw.
- B. While holding the valve adjuster dial in place, use the valve adjuster handle and loosen the jam nut; then rotate the tappet adjuster screw clockwise until friction is felt.
- C. Align the valve adjuster handle with one of the marks on the valve adjuster dial.

D. While holding the valve adjuster handle in place, rotate the valve adjuster dial counterclockwise until proper valve/tappet clearance is attained.

■NOTE: Refer to the appropriate specifications in Feeler Gauge Procedure sub-section for the proper valve/tappet clearance.

■NOTE: Rotating the valve adjuster dial counterclockwise will open the valve/tappet clearance by 0.05 mm (0.002 in.) per mark.

E. While holding the adjuster dial at the proper clearance setting, tighten the jam nut securely with the valve adjuster handle.

3. Install the spark plug; then install the timing inspection plug.
4. Place the two tappet covers with O-rings into position. Tighten the cap screws securely.

Testing Engine Compression

To test engine compression, use the following procedure.

■NOTE: The engine should be warm (operating temperature) and the battery fully charged for an accurate compression test. The throttle must be in the wide-open throttle (WOT) position. In the event the engine can not be run, cold values are included.

■NOTE: The seat, seat back, and seat base must be removed for this procedure.

1. Remove the high tension lead from the spark plug.
2. Using compressed air, blow any debris from around the spark plug.

⚠ WARNING

Always wear safety glasses when using compressed air.

3. Remove the spark plug; then attach the high tension lead to the plug and ground the plug on the cylinder head well away from the spark plug hole.
4. Attach the Compression Tester Kit.
5. While holding the throttle in the full-open position, crank the engine over with the electric starter until the gauge stops climbing (five to 10 compression strokes).

PSI Hot (WOT)	PSI Cold (WOT)
125-145	100-140

6. If compression is abnormally low, inspect the following items.

- A. Starter cranks engine over.
- B. Gauge is functioning properly.
- C. Throttle in the full-open position.
- D. Valve/tappet clearance correct.
- E. Valve bent or burned.
- F. Valve seat burned.
- G. Piston rings worn or bent.
- H. Cylinder worn or scored.
- I. Head gasket blown.

■NOTE: To service top-side components, see Section 3.

- 7. Pour approximately 30 ml (1 fl oz) of oil into the spark plug holes, reattach the gauge, and retest compression.
- 8. If compression is now evident, service the piston rings (see Section 3).

Spark Plug

A light brown insulator indicates that the plug is correct. A white or dark insulator indicates that the engine may need to be serviced. To maintain a hot, strong spark, keep the plug free of carbon.

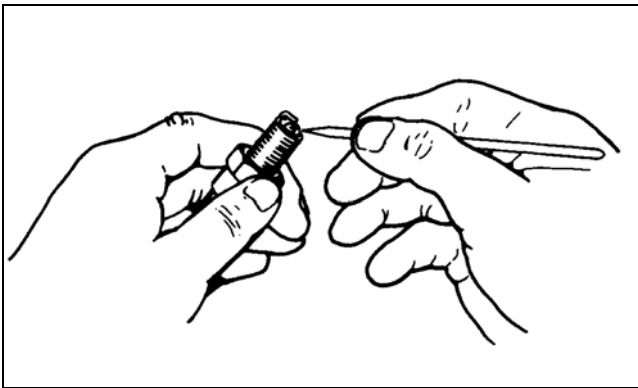

ATV-0051

CAUTION

Before removing the spark plug, be sure to clean the area around the spark plug. Dirt could enter engine when removing or installing the spark plug.

Adjust the gap to 0.7-0.8 mm (0.028-0.032 in.).

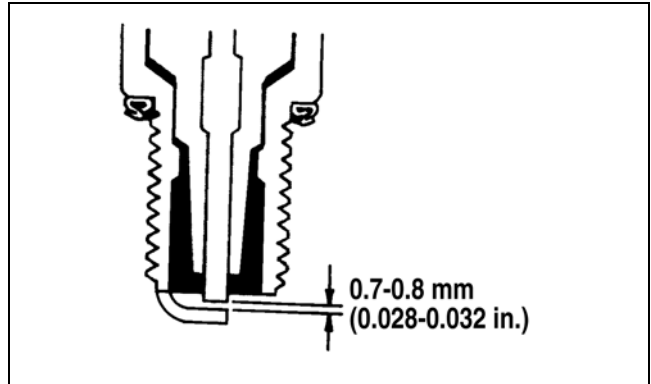

ATV0052C

When installing the spark plug, be sure to tighten it securely. A new spark plug should be tightened 1/2 turn once the washer contacts the cylinder head. A used spark plug should be tightened 1/8-1/4 turn once the washer contacts the cylinder head.

2

Muffler/Spark Arrester

Clean the spark arrester using the following procedure.

WARNING

Wait until the muffler cools to avoid burns.

1. Remove the cap screws securing the spark arrester screen assembly to the muffler; then loosen and remove the spark arrester. Account for a gasket.

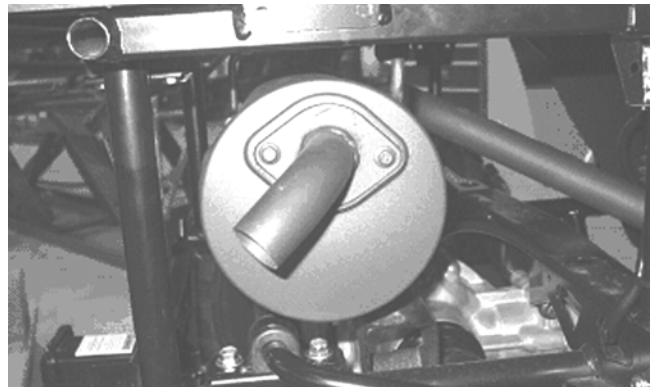

PR498

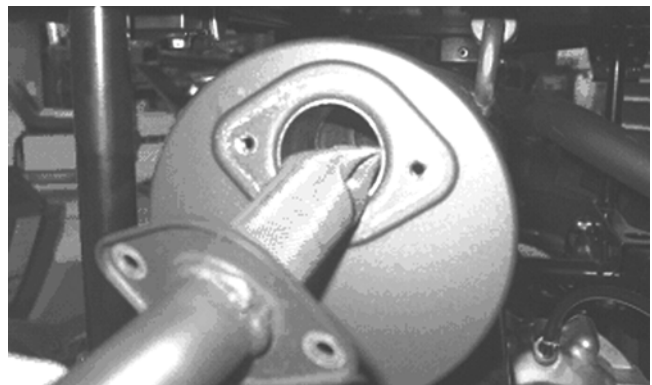

PR499

2. Using a suitable brush, clean the carbon deposits from the screen taking care not to damage the screen.

■NOTE: If the screen or gasket is damaged in any way, it must be replaced.

3. Install the spark arrester assembly and gasket and secure with the cap screws. Tighten the cap screws to 48 in.-lb.

Engine/Transmission Oil - Filter

OIL - FILTER

Change the engine oil and oil filter at the scheduled intervals. The engine should always be warm when the oil is changed so the oil will drain easily and completely.

■NOTE: To change oil and filter, the seats and center console must be removed.

1. Park the vehicle on level ground.
2. Remove the drain plug from the bottom of the engine and drain the oil into a drain pan; then remove the seat, seat back, and seat base.

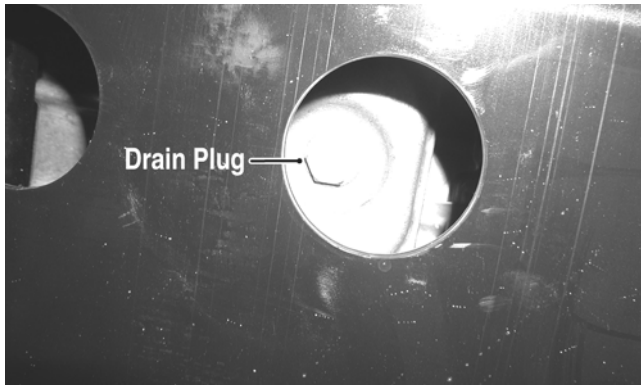

PR078A

3. Using the Oil Filter Wrench and a ratchet handle (or a socket or box-end wrench), remove the old oil filter.

■NOTE: Clean up any excess oil after removing the filter.

4. Apply oil to a new filter O-ring and check to make sure it is positioned correctly; then install the new oil filter. Tighten securely.
5. Install the engine drain plug and tighten to 16 ft-lb. Pour the specified amount of the recommended oil in the filler hole.

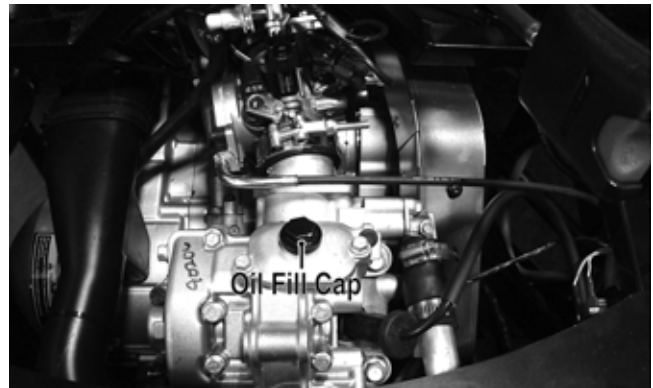

HDX042A

CAUTION

Any oil used in place of the recommended oil could cause serious engine damage. Do not use oils which contain graphite or molybdenum additives. These oils can adversely affect clutch operation. Also, not recommended are racing, vegetable, non-detergent, and castor-based oils.

6. Start the engine (while the vehicle is outside on level ground) and allow it to idle for a few minutes.
7. Turn the engine off and wait approximately one minute; then unscrew the oil level stick and wipe it with a clean cloth.
8. Install the oil level stick and thread into the engine case.
9. Remove the oil level stick; the oil level must be within the operating range but not exceeding the upper mark.



GZ461A

CAUTION

Do not over-fill the engine with oil. Always make sure that the oil level is not above the upper mark.

10. Inspect the area around the drain plug and oil filter for leaks.

Front Differential - Rear Drive Lubricant

To check lubricant, use the following procedure.

1. Remove the fill plug; the lubricant level should be one inch below the plug threads.

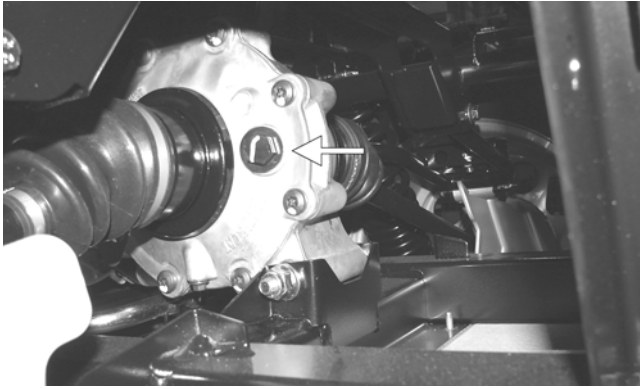

PR530A

2. If low, add SAE approved 80W-90 hypoid gear lube as necessary.

To change the lubricant, use the following procedure.

1. Place the vehicle on level ground.
2. Remove each fill plug.
3. Drain the lubricant into a drain pan by removing in turn the drain plug from each.

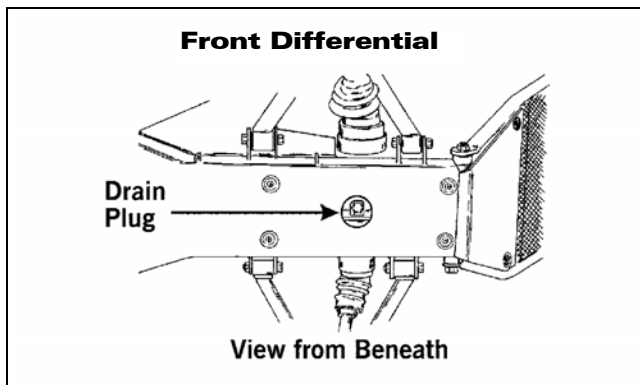

ATV0082A

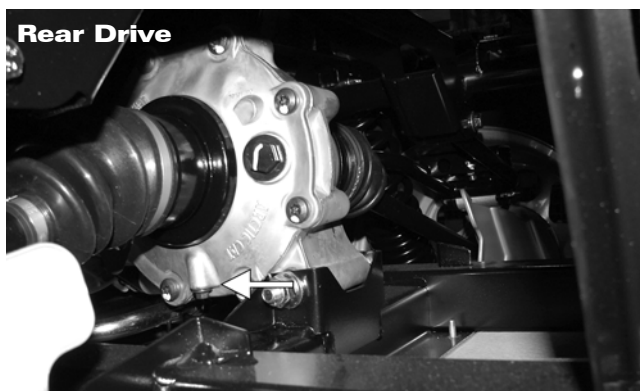

PR530B

4. After all the lubricant has been drained, install the drain plugs and tighten to 45 in.-lb.
5. Pour the appropriate amount of recommended lubricant into the fill hole.
6. Install the fill plug.

■ **NOTE:** If the lubricant is contaminated with water, inspect the drain plug, fill plug, and/or bladder.

Driveshaft/Coupling

The following drive system components should be inspected periodically to ensure proper operation.

- A. Spline lateral movement (slop).
- B. Coupling cracked, damaged, or worn.
- C. Universal joints worn or missing bearings.

2

Nuts/Bolts/Cap Screws

Tighten all nuts, bolts, and cap screws. Make sure rivets holding components together are tight. Replace all loose rivets. Care must be taken that all calibrated nuts, bolts, and cap screws are tightened to specifications.

Headlight/Taillight-Brakelight

HEADLIGHT

■ **NOTE:** The bulb portion of the headlight is fragile. **HANDLE WITH CARE.** When replacing the headlight bulb, do not touch the glass portion of the bulb. If the glass is touched, it must be cleaned with a dry cloth before installing. Skin oil residue on the bulb will shorten the life of the bulb.

⚠ WARNING

Do not attempt to remove the bulb when it is hot. Severe burns may result.

To replace the headlight bulb, use the following procedure.

1. Remove the wiring harness connector from the back of the headlight.
2. Grasp the bulb socket, turn it counterclockwise and remove, and pull the bulb straight out of the socket.
3. Install the new bulb into the socket and rotate it completely clockwise in the housing.
4. Install the wiring harness connector.

TAILLIGHT-BRAKELIGHT

To replace the taillight-brakelight bulb, use the following procedure.

1. Remove the two machine screws and remove the light assembly.
2. Rotate the bulb socket counterclockwise to remove it from the light assembly; then pull straight out on the bulb. Push the new bulb straight into the socket.
3. Install the bulb and socket into the light assembly and turn clockwise to lock in place.
4. Install the taillight-brakelight assembly on the canopy support.

CHECKING/ADJUSTING HEADLIGHT AIM

The headlights can be adjusted vertically. The geometric center of the HIGH beam light zone is to be used for vertical aiming.

1. Position the vehicle on a level floor so the headlights are approximately 6.1 m (20 ft) from an aiming surface (wall or similar aiming surface).

NOTE: There should be an average operating load on the vehicle when adjusting the headlight aim.

2. Measure the distance from the floor to the mid-point of each headlight.
3. Using the measurements obtained in step 2, make horizontal marks on the aiming surface.
4. Make vertical marks which intersect the horizontal marks on the aiming surface directly in front of the headlights.
5. Switch on the lights. Make sure the HIGH beam is on. DO NOT USE LOW BEAM.
6. Observe each headlight beam aim. Proper aim is when the most intense beam is centered on the vertical mark 5 cm (2 in.) below the horizontal mark on the aiming surface.

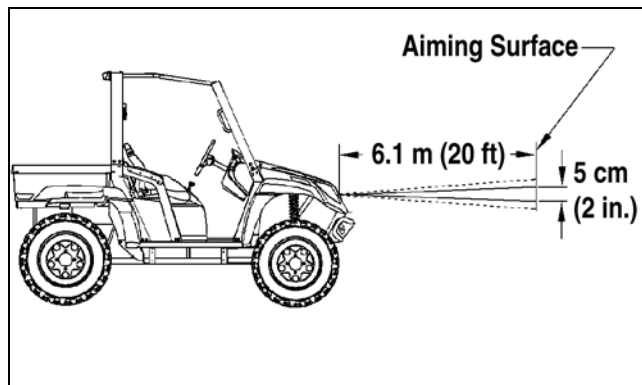

0740-647

7. Using the adjuster knob, adjust each headlight until correct aim is obtained.

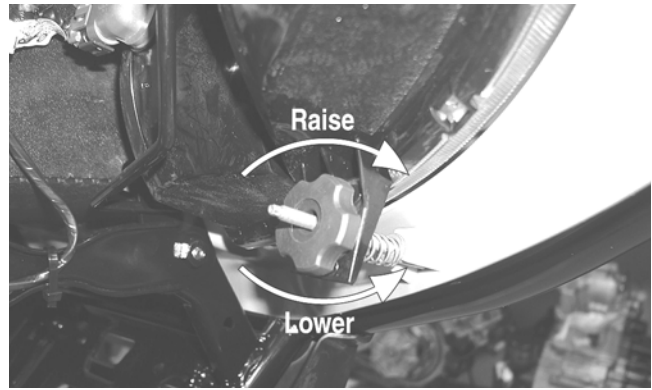

CD714A

Shift Lever

CHECKING SHIFT CABLE ADJUSTMENT

1. Turn the ignition switch on; then with the shift lever in the neutral position, look for the (N) indication on the LCD. Shift into high range and look for the (H) indication, low range for the (L) indication, and reverse for the (R) indication.
2. Shift the transmission into park and observe that the (P) illuminates on the seat belt/park indicator light.

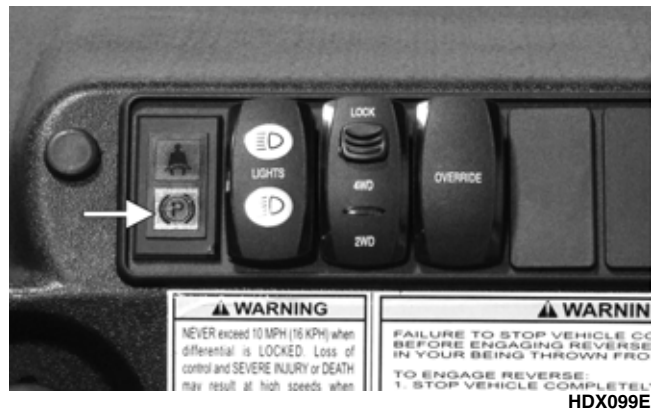

NOTE: If the (P) illuminates before the shift lever is fully in the park position, the park indicator light adjustment must be performed (see ADJUSTING PARK INDICATOR LIGHT in this sub-section).

ADJUSTING SHIFT CABLE

To adjust the shift cable, use the following procedure.

1. Place the transmission in park; then tilt the cargo box.
2. Make sure the shift lever is in park; then remove the E-clip securing the cable end to the shaft arm.



PR567A

3. Loosen nuts (A) and (B) and adjust the cable housing to align the shift cable end to the shift arm stud (C).

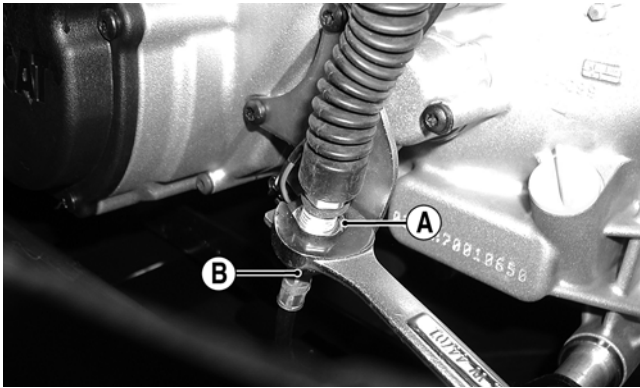

PR568A

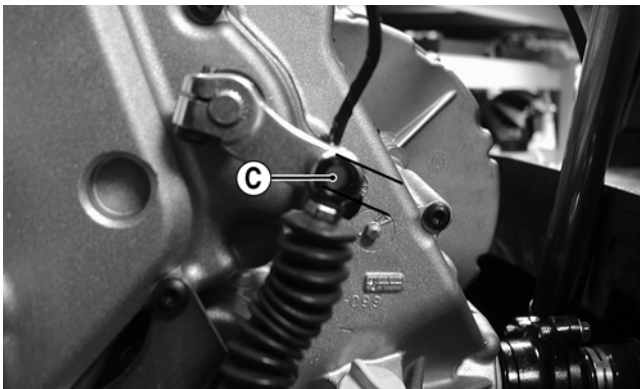

PR572A

4. Install the E-clip; then tighten the nuts (A) and (B) to 20 ft-lb.
5. Check each gear shift position for proper gear selection and make sure the proper icon illuminates on the LCD.

ADJUSTING PARK INDICATOR LIGHT

1. Remove the shift lever boot; then shift the transmission into park.

■NOTE: Verify the transmission is in park by rocking the vehicle. It will not move if in park.



HDX177

2. Loosen the lower mounting nut on the shift cable several turns; then while holding the shifter firmly against the park gate, adjust the upper mounting nut against the mounting bracket.

2

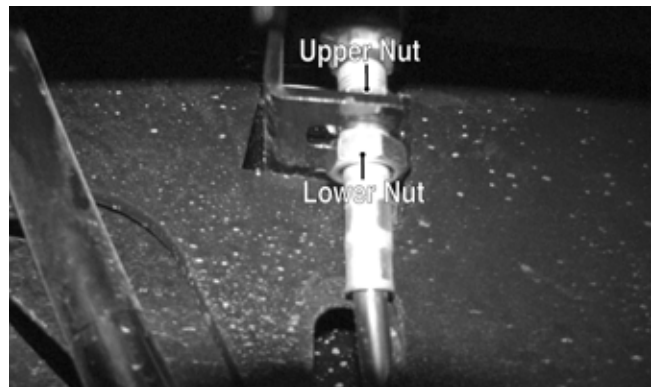

HDX178A

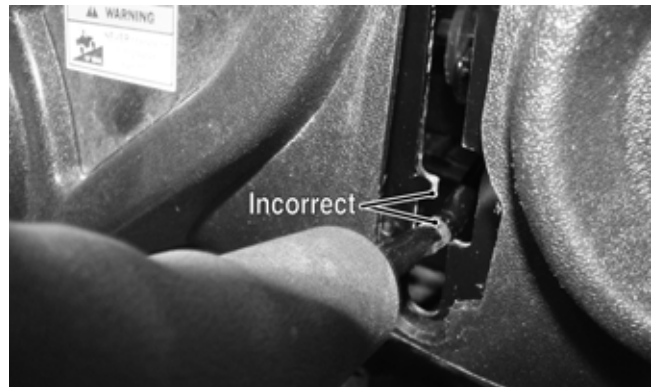

HDX177A

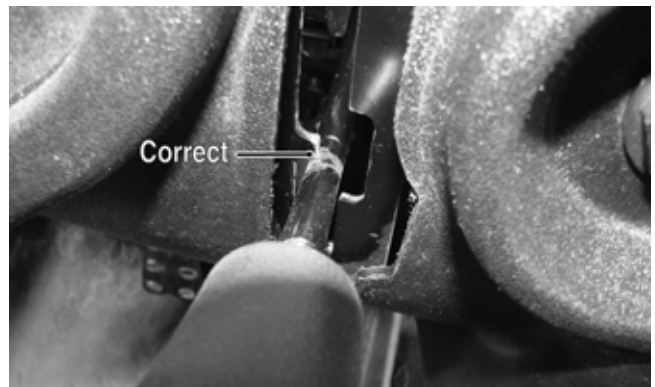

HDX179A

3. Tighten the lower mounting nut to 20 ft-lb; then turn the ignition switch to the ON position and check that the park indicator light only illuminates when fully in the park position.
4. With the ignition switch still on, shift to each gear position and observe the gear position icons on the LCD gauge. Verify each position (R, N, H, and L) can be selected.

Hydraulic Brake System

■NOTE: This ROV is equipped with hydraulic brakes at all four wheels.

CHECKING/BLEEDING

The hydraulic brake system has been filled and bled at the factory. To check and/or bleed a hydraulic brake system, use the following procedure.

1. With the master cylinder in a level position, check the fluid level in the reservoir. If the level in the reservoir is not above the MIN, add DOT 4 brake fluid.



PR095

2. Depress the brake pedal several times to check for a firm brake. If the brake is not firm, the system must be bled.
3. To bleed the brake system, use the following procedure.
 - A. Remove the cover and fill the reservoir with DOT 4 Brake Fluid.
 - B. Install and secure the cover; then slowly depress the brake pedal several times.
 - C. Remove the protective cap, install one end of a clear hose onto one FRONT bleeder screw, and direct the other end into a container; then while holding slight pressure on the brake pedal, open the bleeder screw and watch for air bubbles. Close the bleeder screw before releasing the brake pedal. Repeat this procedure until no air bubbles are present.



AF637D

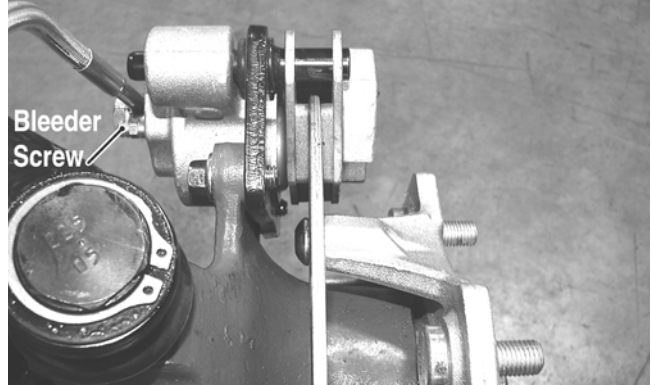

PR377C

■NOTE: During the bleeding procedure, watch the reservoir very closely to make sure there is always a sufficient amount of brake fluid. When the level falls below MIN, refill the reservoir before the bleeding procedure is continued. Failure to maintain a sufficient amount of fluid in the reservoir will result in air in the system.

- D. At this point, perform steps B and C on the other FRONT bleeder screw; then move to the REAR bleeder screw(s) and follow the same procedure.
 - E. Repeat steps B and C until the brake pedal is firm.
4. Carefully check the entire hydraulic brake system that all hose connections are tight, the bleed screws are tight, the protective caps are installed, and no leakage is present.

CAUTION

This hydraulic brake system is designed to use DOT 4 brake fluid only. If brake fluid must be added, care must be taken as brake fluid is very corrosive to painted surfaces.

INSPECTING HOSES

Carefully inspect the hydraulic brake hoses for cracks or other damage. If found, the brake hoses must be replaced.

CHECKING/REPLACING PADS

The clearance between the brake pads and brake discs is adjusted automatically as the brake pads wear. The only maintenance that is required is replacement of the brake pads when they show excessive wear. Check the thickness of each of the brake pads as follows.

1. Remove the wheel corresponding to the brake being checked.
2. Measure the thickness of each brake pad.

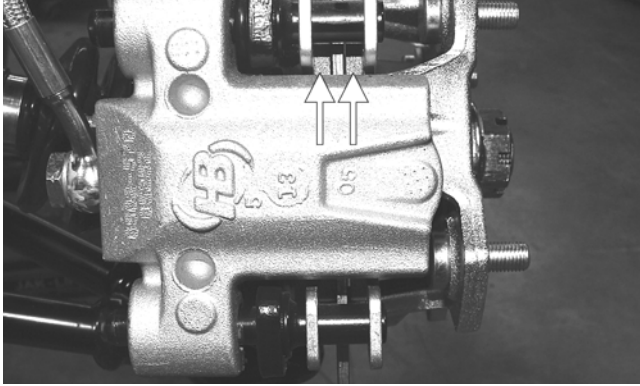

PR376A

3. If thickness of either brake pad is less than 1.0 mm (0.039 in.), the brake pads must be replaced.

■ **NOTE:** The brake pads should be replaced as a set.

4. To replace the brake pads, use the following procedure.
 - A. Remove the cap screws securing the caliper holder to the knuckle; then remove the pads from the caliper.

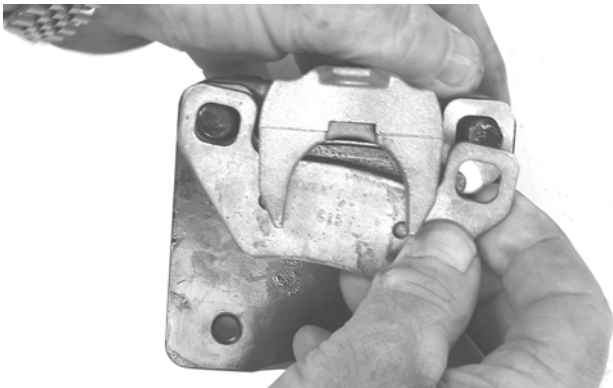

PR237

- B. Install the new brake pads.
- C. Secure the caliper holder to the knuckle with new "patch-lock" cap screws. Tighten to 20 ft-lb.

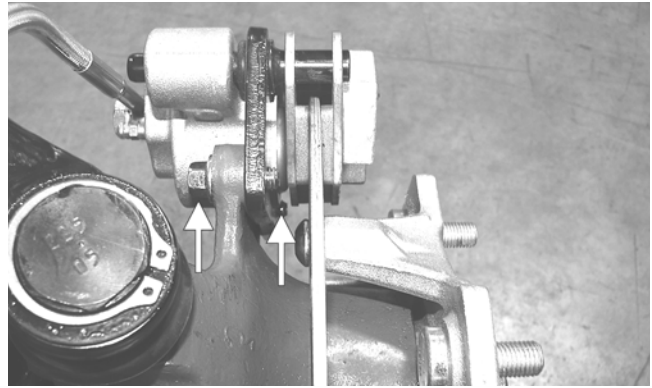

PR377B

5. Install the wheel. Tighten to 80 ft-lb.
6. Burnish the brake pads (see Burnishing Brake Pads in this section).

BRAKE DISC

Using a micrometer, measure the thickness of the brake disc in the contact surface. If thickness is 0.125-in. or less, the disc must be replaced. To replace the brake disc, see Section 6 – Hub.

2

Burnishing Brake Pads

Brake pads must be burnished to achieve full braking effectiveness. Braking distance will be extended until brake pads are properly burnished. To properly burnish the brake pads, use the following procedure.

WARNING

Failure to properly burnish the brake pads could lead to premature brake pad wear or brake loss. Brake loss can result in severe injury.

1. Choose an area large enough to safely accelerate the vehicle to 30 mph and to brake to a stop.
2. Accelerate to 30 mph; then depress the brake pedal to decelerate to 0-5 mph.
3. Repeat procedure 20 times until brake pads are burnished.

Checking/Replacing V-Belt

REMOVING

1. Remove the seat, seat back, and seat base.
2. Remove the cap screws securing the V-belt cover noting the location of the different-lengthed cap screws for installing purposes; then using a rubber mallet, gently tap on the cover tabs to loosen the cover. Remove the cover.

- Remove the nut securing the movable drive face; then remove the face. Account for the flat washer and spacer.

■NOTE: Keep the drive face plate in contact with the drive face when removing or installing the drive face to prevent the rollers from falling out.

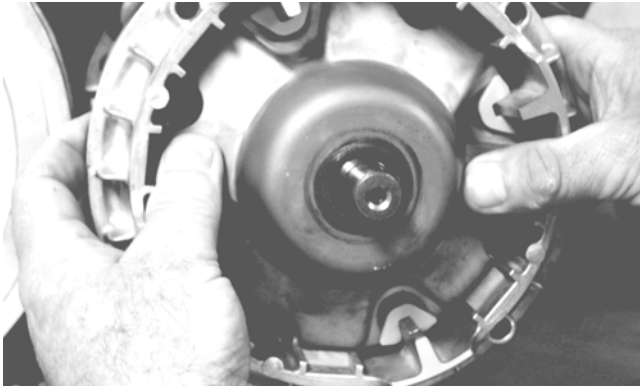

CD963

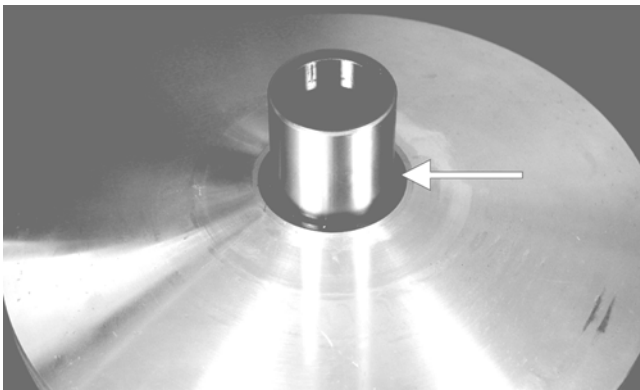

CD966A

- Install one of the V-belt cover cap screws into the driven pulley fixed face; then turn the cap screw clockwise to spread the pulley faces. Remove the V-belt.



PR476A

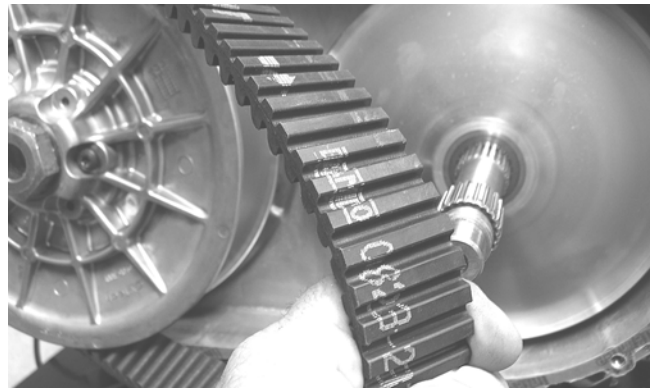

GZ085

INSTALLING

- Place the V-belt into position on the driven pulley and over the front shaft.

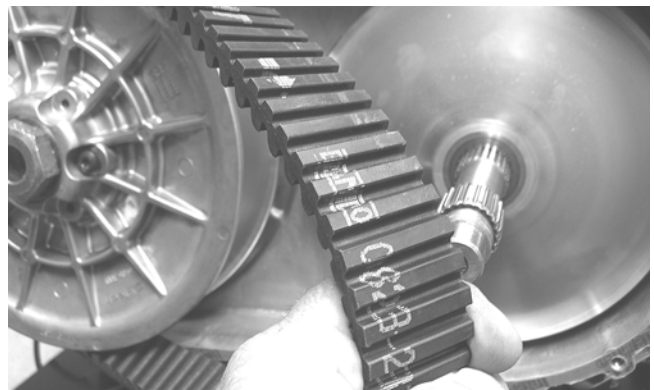

GZ085

■NOTE: The arrows on the V-belt should point forward.

- Pinch the V-belt together near its center and slide the spacer and movable drive face onto the driveshaft. Secure the drive face with a washer and nut (coated with red Loctite #271). Tighten the nut to 165 ft-lb.

CAUTION

Make sure the movable drive face plate is fully engaged onto the splines of the clutch shaft before torquing the nut or false torque readings may occur. This will cause the assembly to loosen damaging the shaft and clutch face plate.

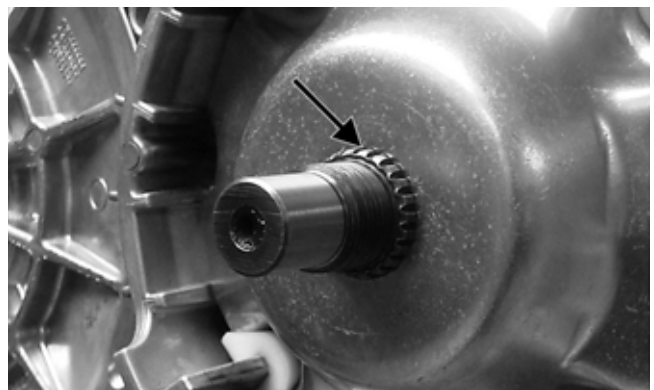

GZ485A

■NOTE: At this point, remove the cap screw from the driven pulley face.

3. Rotate the V-belt and driven pulley/clutch until the V-belt is flush with the top of the driven pulley.

4. Place the V-belt cover gasket into position; then install the cover and secure with the cap screws making sure the different-lengthed cap screws are in their proper location. Tighten the cap screws to 8 ft-lb.

5. Install the seat, seat back, and seat base.

Troubleshooting Brake System

Problem: Braking poor	
Condition	Remedy
<ol style="list-style-type: none"> 1. Pad worn 2. Brake fluid leaking 3. Master cylinder/brake cylinder seal worn 	<ol style="list-style-type: none"> 1. Replace pads 2. Repair - replace hydraulic system 3. Replace seal(s)
Problem: Brake pedal travel excessive	
Condition	Remedy
<ol style="list-style-type: none"> 1. Brake fluid low 2. Brake fluid incorrect 3. Piston seal - cup worn 	<ol style="list-style-type: none"> 1. Add fluid to proper level 2. Replace with correct fluid 3. Replace seal - cup
Problem: Brake fluid leaking	
Condition	Remedy
<ol style="list-style-type: none"> 1. Connection joints loose 2. Hose cracked 3. Piston seal worn 	<ol style="list-style-type: none"> 1. Tighten joint 2. Replace hose 3. Replace seal
Problem: Brake pedal spongy	
Condition	Remedy
<ol style="list-style-type: none"> 1. Air trapped in hydraulic system 2. Brake fluid low 	<ol style="list-style-type: none"> 1. Bleed hydraulic system 2. Add brake fluid and bleed hydraulic brake system

SECTION 3 - ENGINE/TRANSMISSION

TABLE OF CONTENTS

Engine/Transmission 3-2
Specifications 3-2
Troubleshooting 3-3
Prowler HDX (Table of Contents) 3-6

Engine/Transmission

This section has been organized into sub-sections which show a progression for the complete servicing of the Arctic Cat ROV engine/transmission.

To service the center crankcase halves, the engine/transmission must be removed from the frame. To service top-side, left-side, and right-side components, the engine/transmission does not have to be removed from the frame.

■**NOTE:** Arctic Cat recommends the use of new gaskets, lock nuts, and seals and lubricating all internal components when servicing the engine/transmission.

■**NOTE:** Some photographs and illustrations used in this section are used for clarity purposes only and are not designed to depict actual conditions.

■**NOTE:** Critical torque specifications are located in Section 1.

SPECIAL TOOLS

A number of special tools must be available to the technician when performing service procedures in this section. Refer to the current Special Tools Catalog for the appropriate tool description.

Description	p/n
Seal Protector Tool	0444-252
Crankcase Separator/Crankshaft Remover	0444-152
Magneto Rotor Remover Set	0444-254
Piston Pin Puller	0644-328
Secondary Drive Gear Holder	0444-253
Spanner Wrench	0544-005
Surface Plate	0644-016
V Blocks	0644-535

■**NOTE:** Special tools are available from the Arctic Cat Service Parts Department.

Specifications

VALVES AND GUIDES		
Valve Face Diameter	(intake) (exhaust)	31.6 mm 27.9 mm
Valve/Tappet Clearance (cold engine)	(intake) (exhaust)	0.1016 mm 0.1524 mm
Valve Guide/Stem Clearance	(intake/exhaust)	0.013 mm
Valve Guide/Valve Stem Deflection (wobble method)	(max)	0.35 mm
Valve Guide Inside Diameter		5.000-5.012 mm
Valve Stem Outside Diameter	(intake/exhaust)	4.972-4.987 mm
Valve Stem Runout	(max)	0.1 mm
Valve Head Thickness	(min)	2.3 mm
Valve Stem End Length (mm)		3.97 mm
Valve Face/Seat Width	(intake) (exhaust)	2.25 mm 2.60 mm
Valve Seat Angle	(intake/exhaust)	45°
Valve Face Radial Runout	(max)	0.2 mm
Valve Spring Free Length	(min)	38.7 mm
Valve Spring Tension @ 31.5 mm	(outer)	19.0 kg (42 lb)
CAMSHAFT AND CYLINDER HEAD		
Cam Lobe Height (min)	(intake/exhaust)	33.53 mm
Camshaft Journal Oil Clearance	(max)	0.04 mm
Camshaft Runout	(max)	0.05 mm
Rocker Arm Inside Diameter	(max)	12.018 mm
Rocker Arm Shaft Outside Diameter	(min)	11.97 mm
Cylinder Head/Cover Distortion	(max)	0.05 mm
CYLINDER, PISTON, AND RINGS		
Piston Skirt/Cylinder Clearance		0.045 mm
Piston Diameter 15 mm from Skirt End		101.930-101.949 mm
Piston Ring Free End Gap	(1st/2nd)	12.5 mm
Bore x Stroke		102 x 85 mm
Cylinder Trueness	(max)	0.01 mm
Piston Ring End Gap - Installed		0.36 mm
Piston Ring to Groove Clearance (1st/2nd)	(max)	0.03 mm
Piston Ring Groove Width	(1st/2nd) (oil)	1.202-1.204 mm 2.01-2.03 mm
Piston Ring Thickness	(1st/2nd)	1.970-1.990 mm
Piston Pin Bore	(max)	23.0 mm
Piston Pin Outside Diameter	(min)	22.99 mm
CRANKSHAFT		
Connecting Rod (small end inside diameter)	(max)	23.021 mm
Connecting Rod (big end side-to-side)		0.6 mm
Connecting Rod @ 150 mm (small end deflection)	(max)	0.3 mm
Crankshaft (web-to-web)		71 mm
Crankshaft Runout	(max)	0.03 mm

Specifications subject to change without notice.

Troubleshooting

Problem: Engine will not start or is hard to start (Compression too low)	
Condition	Remedy
<ol style="list-style-type: none"> 1. Valve clearance out of adjustment 2. Valve guides worn 3. Valves mistimed 4. Piston rings worn - broken 5. Cylinder bore worn 6. Starter motor cranks too slowly - does not turn 	<ol style="list-style-type: none"> 1. Adjust clearance 2. Repair - replace guides 3. Retime engine 4. Replace rings 5. Replace - rebore cylinder 6. See Section 5
Problem: Engine will not start or is hard to start (No spark)	
Condition	Remedy
<ol style="list-style-type: none"> 1. Spark plug fouled 2. Spark plug wet 3. Magneto defective 4. ECU defective 5. Ignition coil defective 6. High-tension lead open - shorted 	<ol style="list-style-type: none"> 1. Clean - replace plug 2. Clean - dry plug 3. Replace magneto 4. Replace ECU 5. Replace ignition coil 6. Replace high tension lead
Problem: Engine will not start or is hard to start (No fuel reaching the fuel injector)	
Condition	Remedy
<ol style="list-style-type: none"> 1. Gas tank vent hose obstructed 2. Fuel hose obstructed 3. Fuel screens obstructed 4. Fuel pump defective 	<ol style="list-style-type: none"> 1. Clean vent hose 2. Clean - replace hose 3. Clean - replace inlet screen - valve screen 4. Replace fuel pump
Problem: Engine stalls easily	
Condition	Remedy
<ol style="list-style-type: none"> 1. Spark plug fouled 2. Magneto defective 3. ECU defective 4. Fuel injector obstructed 5. Valve clearance out of adjustment 	<ol style="list-style-type: none"> 1. Clean - replace plug 2. Replace magneto 3. Replace ECU 4. Replace fuel injector 5. Adjust clearance
Problem: Engine noisy (Excessive valve chatter)	
Condition	Remedy
<ol style="list-style-type: none"> 1. Valve clearance excessive 2. Valve spring(s) weak - broken 3. Rocker arm - rocker arm shaft worn 4. Camshaft worn 	<ol style="list-style-type: none"> 1. Adjust clearance 2. Replace spring(s) 3. Replace arm - shaft 4. Replace camshaft
Problem: Engine noisy (Noise seems to come from piston)	
Condition	Remedy
<ol style="list-style-type: none"> 1. Piston - cylinder worn 2. Combustion chamber carbon buildup 3. Piston pin - piston pin bore worn 4. Piston rings - ring groove(s) worn 	<ol style="list-style-type: none"> 1. Replace - service piston - cylinder 2. Clean cylinder head and piston 3. Replace - service pin - bore 4. Replace rings - piston
Problem: Engine noisy (Noise seems to come from timing chain)	
Condition	Remedy
<ol style="list-style-type: none"> 1. Chain stretched 2. Sprockets worn 3. Tension adjuster malfunctioning 	<ol style="list-style-type: none"> 1. Replace chain 2. Replace sprockets 3. Repair - replace adjuster

Problem: Engine noisy (Noise seems to come from crankshaft)	
Condition	Remedy
<ol style="list-style-type: none"> 1. Main bearing worn - burned 2. Lower rod-end bearing worn - burned 3. Connecting rod side clearance too large 4. Centrifugal clutch loose 5. Rotor/flywheel loose 	<ol style="list-style-type: none"> 1. Replace bearing 2. Replace bearing 3. Replace crankshaft assembly 4. Tighten - replace clutch 5. Tighten - replace flywheel - crankshaft
Problem: Engine noisy (Noise seems to come from transmission)	
Condition	Remedy
<ol style="list-style-type: none"> 1. Gears worn - rubbing 2. Splines worn 3. Primary gears worn - rubbing 4. Bearings worn 5. Bushing worn 	<ol style="list-style-type: none"> 1. Replace gears 2. Replace shaft(s) 3. Replace gears 4. Replace bearings 5. Replace bushing
Problem: Engine noisy (Noise seems to come from secondary bevel gear and final driven shaft)	
Condition	Remedy
<ol style="list-style-type: none"> 1. Drive - driven bevel gears damaged - worn 2. Backlash excessive 3. Tooth contact improper 4. Bearing damaged 5. Gears worn - rubbing 6. Splines worn 7. Final driven shaft thrust clearance too large 	<ol style="list-style-type: none"> 1. Replace gears 2. Adjust backlash 3. Adjust contact 4. Replace bearing 5. Replace gears 6. Replace shaft(s) 7. Replace thrust washer(s)
Problem: Engine idles poorly	
Condition	Remedy
<ol style="list-style-type: none"> 1. Valve clearance out of adjustment 2. Valve seating poor 3. Valve guides defective 4. Rocker arms - arm shaft worn 5. Magneto defective 6. ECU defective 7. Spark plug fouled - gap too wide 8. Ignition coil defective 9. Fuel injector obstructed 	<ol style="list-style-type: none"> 1. Adjust clearance 2. Replace - service seats - valves 3. Replace guides 4. Replace arms - shafts 5. Replace magneto 6. Replace ECU 7. Adjust gap - replace plug 8. Replace ignition coil 9. Replace fuel injector
Problem: Engine runs poorly at high speed	
Condition	Remedy
<ol style="list-style-type: none"> 1. High RPM "cut out" against RPM limiter 2. Valve springs weak 3. Valve timing out of adjustment 4. Cams - rocker arms worn 5. Spark plug gap too narrow 6. Ignition coil defective 7. Air cleaner element obstructed 8. Fuel hose obstructed 	<ol style="list-style-type: none"> 1. Shift into higher gear - decrease speed 2. Replace springs 3. Adjust timing 4. Replace cams - arms 5. Adjust gap 6. Replace ignition coil 7. Clean element 8. Clean - prime hose
Problem: Exhaust smoke dirty or heavy	
Condition	Remedy
<ol style="list-style-type: none"> 1. Engine oil overfilled - contaminated 2. Piston rings - cylinder worn 3. Valve guides worn 4. Cylinder wall scored - scuffed 5. Valve stems worn 6. Stem seals defective 	<ol style="list-style-type: none"> 1. Drain excess oil - change oil 2. Replace - service rings - cylinder 3. Replace guides 4. Replace cylinder 5. Replace valves 6. Replace seals

Problem: Engine lacks power

Condition	Remedy
1. Valve clearance incorrect	1. Adjust clearance
2. Valve springs weak	2. Replace springs
3. Valve timing out of adjustment	3. Time camshaft
4. Piston ring(s) - cylinder worn	4. Replace - service rings - cylinder
5. Valve seating poor	5. Repair seats
6. Spark plug fouled	6. Clean - replace plug
7. Rocker arms - shafts worn	7. Replace arms - shafts
8. Spark plug gap incorrect	8. Adjust gap - replace plug
9. Fuel injector obstructed	9. Replace fuel injector
10. Air cleaner element obstructed	10. Clean element
11. Engine oil overfilled - contaminated	11. Drain excess oil - change oil
12. Intake manifold leaking air	12. Tighten - replace manifold
13. Cam chain worn	13. Replace cam chain - sprockets

Problem: Engine overheats

Condition	Remedy
1. Carbon deposit (piston crown) excessive	1. Clean piston
2. Oil low	2. Add oil
3. Octane low - gasoline poor	3. Drain - replace gasoline
4. Oil pump defective	4. Replace pump
5. Oil circuit obstructed	5. Clean circuit
6. Intake manifold leaking air	6. Tighten - replace manifold
7. Coolant level low	7. Fill - examine system for leaks
8. Fan malfunctioning	8. Check fan fuse - replace fan
9. Fan switch malfunctioning	9. Replace fan switch
10. Thermostat stuck - closed	10. Replace thermostat
11. Radiator hoses - cap damaged - obstructed	11. Clear obstruction - replace hoses

Prowler HDX (Table of Contents)

Removing Engine/Transmission.....	3-6
Top-Side Components.....	3-9
Removing Top-Side Components	3-9
Servicing Top-Side Components.....	3-13
Installing Top-Side Components	3-20
Left-Side Components	3-25
Removing Left-Side Components	3-25
Installing Left-Side Components	3-27
Right-Side Components.....	3-30
Removing Right-Side Components.....	3-30
Servicing Right-Side Components	3-33
Installing Right-Side Components.....	3-34
Center Crankcase Components.....	3-37
Separating Crankcase Halves.....	3-38
Disassembling Crankcase Half	3-38
Servicing Center Crankcase Components.....	3-40
Assembling Crankcase Half	3-46
Joining Crankcase Halves.....	3-47
Installing Engine/Transmission.....	3-48

Removing Engine/Transmission

Many service procedures can be performed without removing the engine/transmission from the frame. Closely observe the note introducing each sub-section for this important information.

AT THIS POINT

If the technician's objective is to service/replace right-side cover oil seals, front output joint oil seal, rear output joint oil seal, and/or the oil strainer (from beneath the engine/transmission), the engine/transmission does not have to be removed from the frame.

Support the vehicle on a suitable lift or jack stands allowing room to perform work from the underside.

NOTE: Locate the jack stands to allow removing of the center belly panel.

WARNING

Make sure the vehicle is solidly supported on the support stands to avoid injury.

1. Remove the seat, seat back, and seat base; then remove the battery cover and disconnect the negative battery cable.
2. Remove the center skid plate; then drain the oil and coolant.

3. Remove the center floorboard.
4. Marking all nylon tie locations for installing purposes, from the right side disconnect the MAP sensor connector (A), fuel injector connector (B), ISC connector (C), and TPS connector (D).

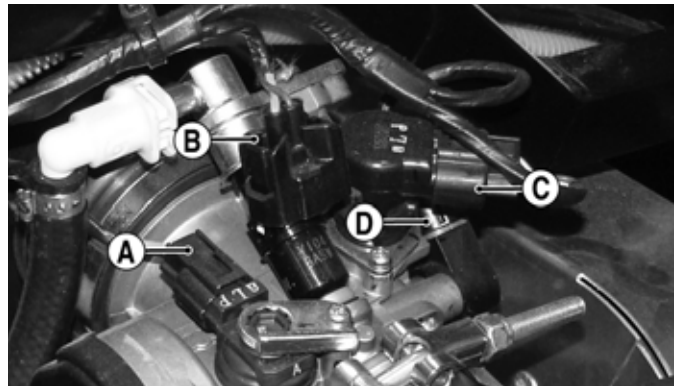

HDX136A

5. Wrap the gasoline hose connector with a shop cloth; then remove the gasoline hose connector from the fuel rail.

WARNING

Gasoline may be under pressure. Place an absorbant towel around the connector to absorb any gasoline spray when disconnected.



HDX138A

6. Loosen the clamp securing the air filter intake tube to the air filter; then remove the mounting screw and remove the intake tube.



HDX031A

- Remove four sheet metal screws securing the air filter mounting bracket to the frame; then loosen the air inlet boot clamp and disconnect the IAT sensor connector and remove the air filter assembly.

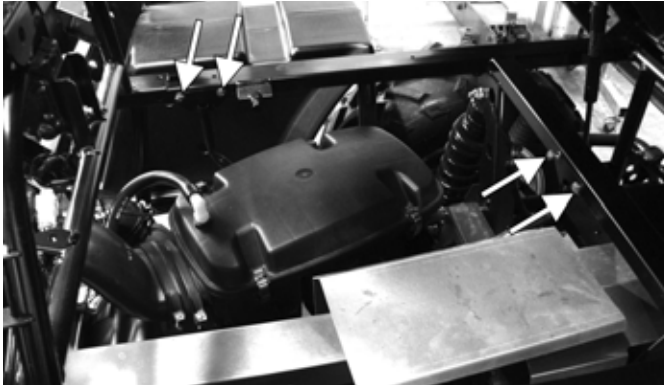

HDX148A

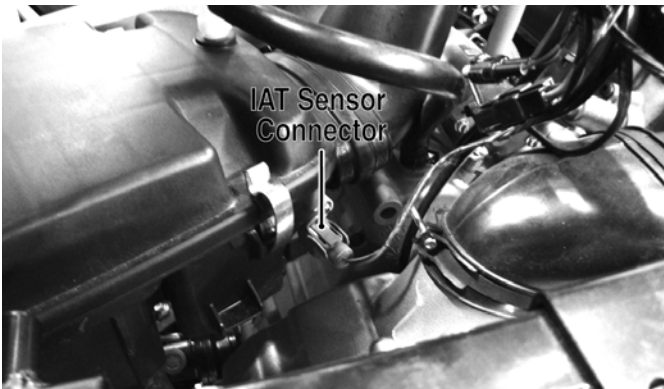

HDX144A

- Loosen the clamp securing the throttle body to the intake manifold boot; then remove the throttle body and set aside.
- From the left side, disconnect the ECT sensor connector, speed sensor connector, and spark plug cap.

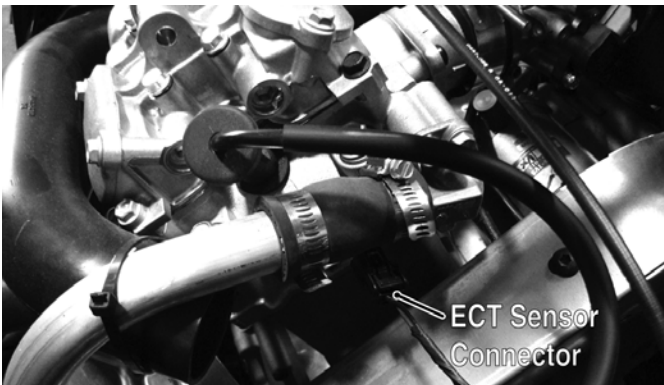

HDX135A

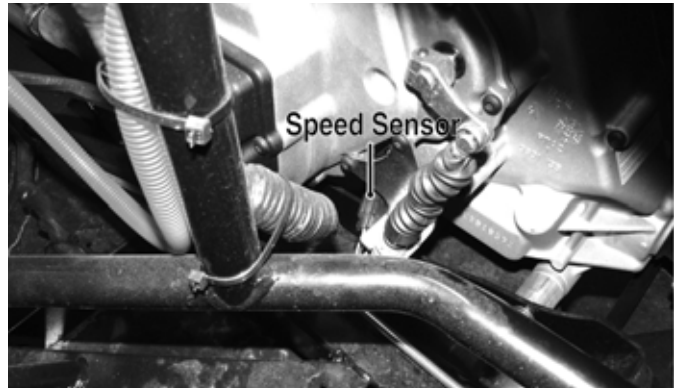

HDX137A

- Remove the E-clip from the shift arm; then remove the cap screws securing the shift cable bracket to the engine case. Remove the shift cable from the shift arm and engine.

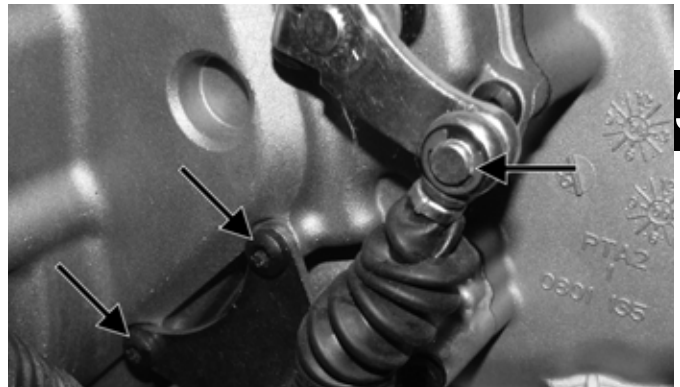

HDX142A

- Disconnect the starter cable from the starter; then remove the cap screw securing the engine/harness ground wires to the engine case.

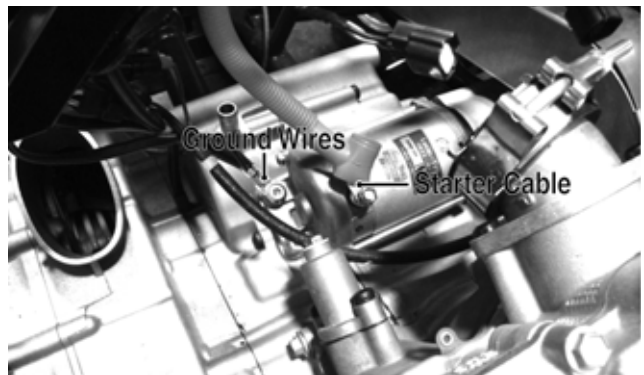

HDX149A

- Remove the CVT inlet and exhaust ducts from the V-belt housing.

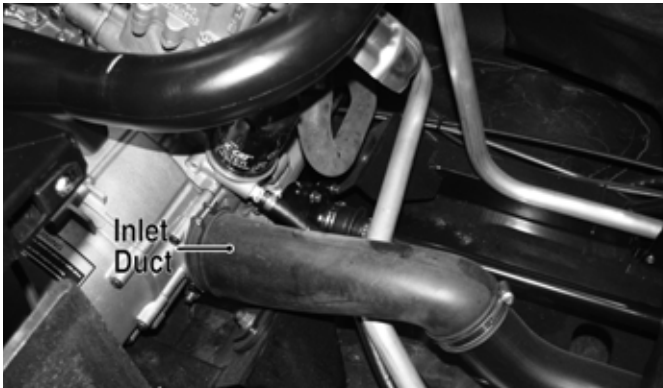

HDX146A

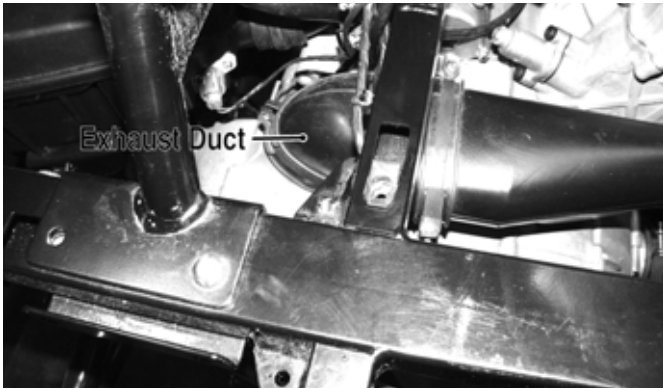

HDX147A

13. Remove the forward heat shield from the exhaust pipe; then remove the cap screws securing the exhaust pipe to the cylinder head.

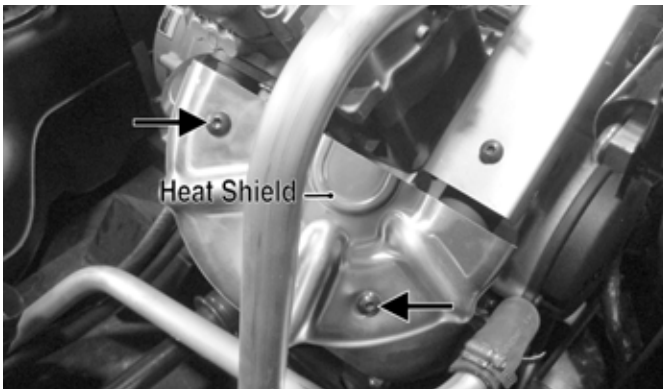

HDX152A

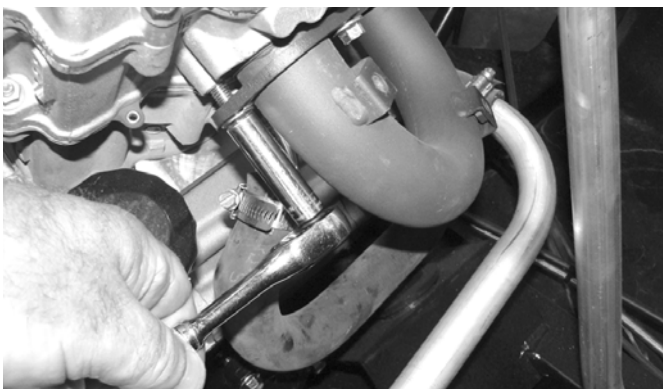

HDX154

14. Remove the two exhaust springs at the muffler; then remove the exhaust pipe. Account for a grafoil seal in the cylinder head and a grafoil seal at the muffler.

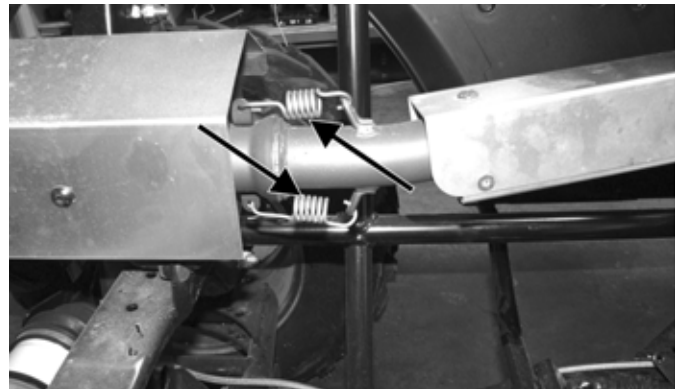

HDX153A

15. Remove the cap screws securing the driveshafts to the front and rear engine flanges; then disconnect the upper and lower coolant hoses.

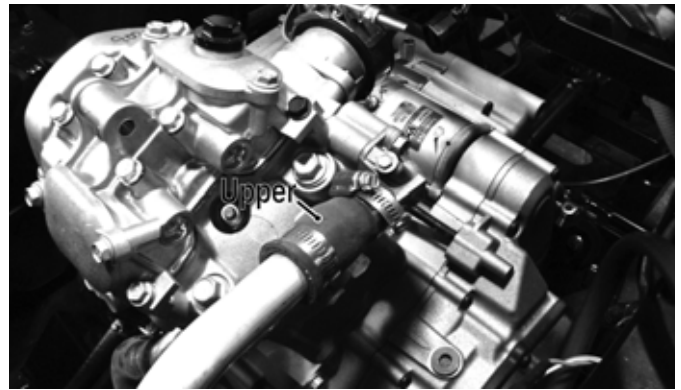

HDX158A

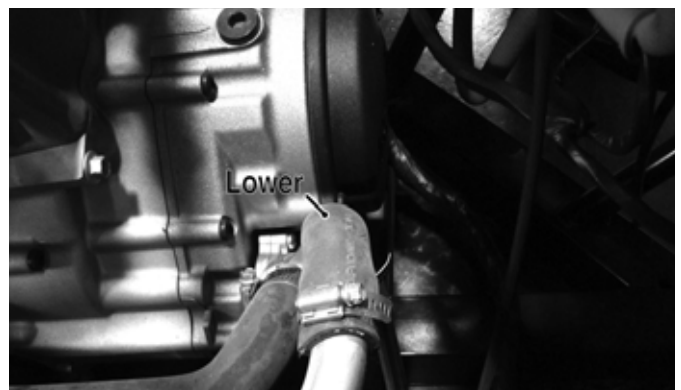

HDX159A

16. Disconnect the oil cooler lines and plug them to prevent oil spillage.

17. Remove the nuts from the rear engine mounts; then remove the front through-bolt.

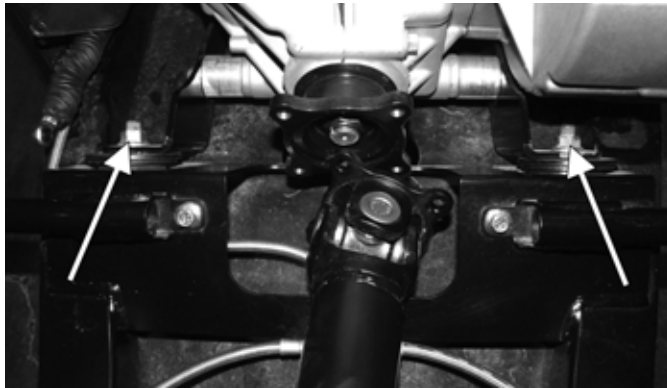

HDX157A

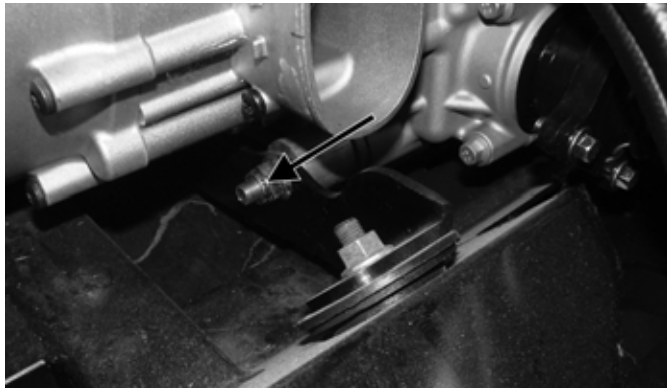

HDX156A

18. Attach a suitable lifting sling and with a suitable engine hoist, lift the engine from the vehicle.

Top-Side Components

■NOTE: For efficiency, it is preferable to remove and disassemble only those components which need to be addressed and to service only those components. The technician should use discretion and sound judgment.

AT THIS POINT

To service any one specific component, only limited disassembly of components may be necessary. Note the AT THIS POINT information in each sub-section.

■NOTE: The engine/transmission does not have to be removed from the frame for this procedure.

Removing Top-Side Components

- A. Valve Cover
- B. Cylinder Head

■NOTE: Remove the spark plug and timing inspection plug; then using an appropriate wrench, rotate the crankshaft to top-dead-center of the compression stroke.

1. Remove the two tappet covers.



CC001D

■NOTE: Keep the mounting hardware with the covers for assembly purposes or thread them back into the head to keep them separated.

2. Remove the 12 cap screws securing the valve cover to the head; account for the four rubber washers on the top side cap screws. Remove the valve cover. Account for and note the orientation of the cylinder head plug. Note the location of two alignment pins.

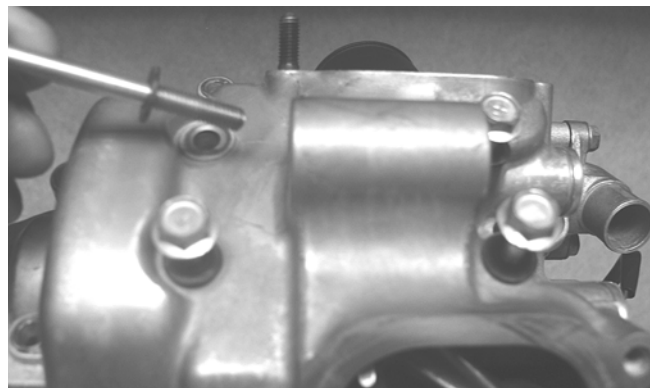

CD205

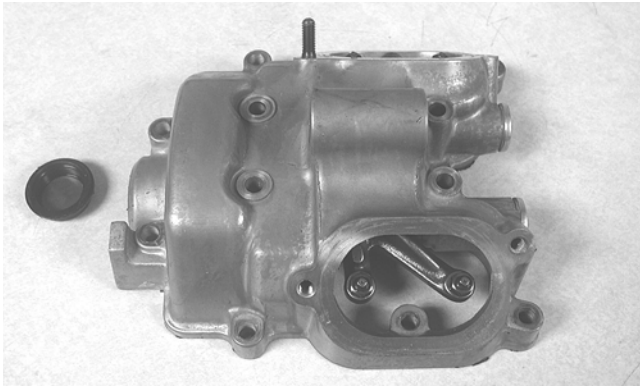

CD206

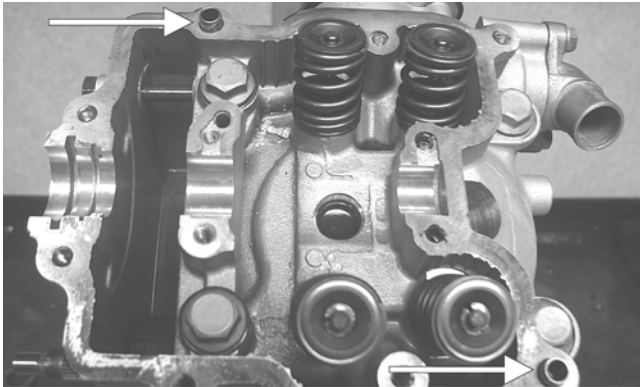

CD211A

- Loosen the cap screw on the end of the tensioner; then remove the two cap screws securing the tensioner adjuster assembly and remove the assembly. Account for a gasket.



CC009D

- Using an awl, rotate the C-ring in its groove until it is out of the cylinder head; then remove the C-ring.

■NOTE: Care should be taken not to drop the C-ring down into the crankcase.

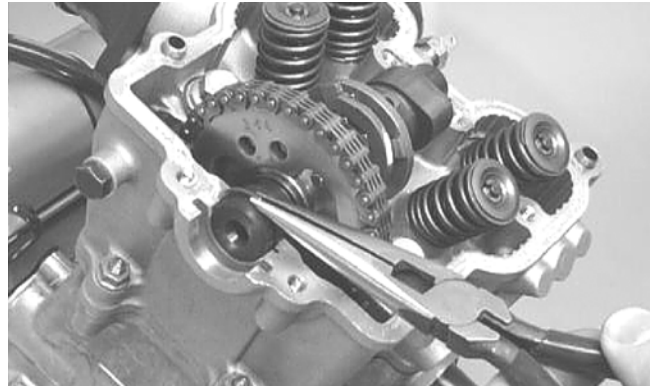

CC012D

- Bend the washer tabs down and remove the two cap screws securing the sprocket to the camshaft; then drop the sprocket off the camshaft.

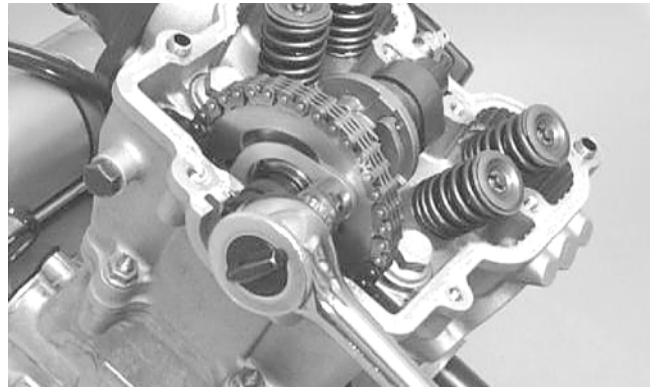

CC013D

- While holding the chain, slide the sprocket and camshaft out of the cylinder head.

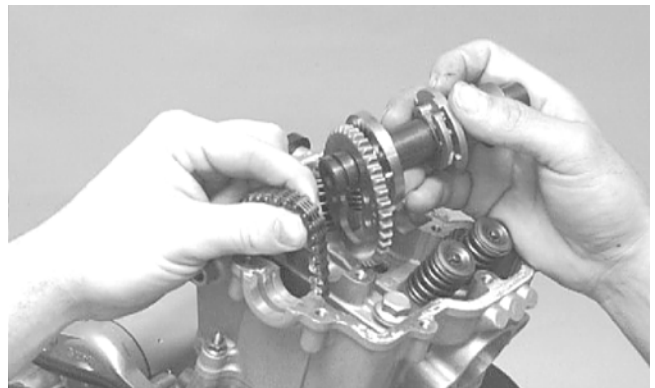

CC266D

- Remove the cap screw securing the chain tensioner (account for a washer); then remove the tensioner.



CC014D

■NOTE: Loop the chain over the cylinder and secure it to keep it from falling into the crankcase.

- Remove the five nuts securing the cylinder head to the cylinder; then remove the four cylinder head cap screws.

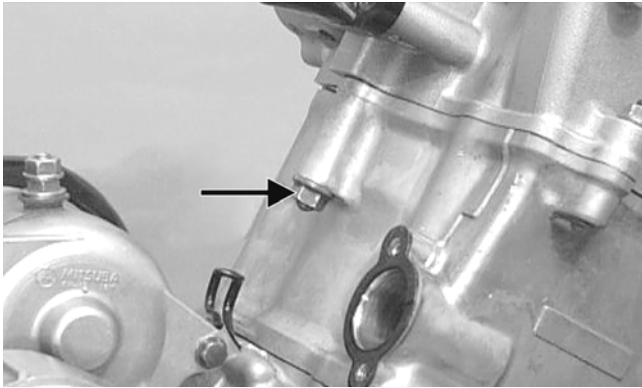

CC017D

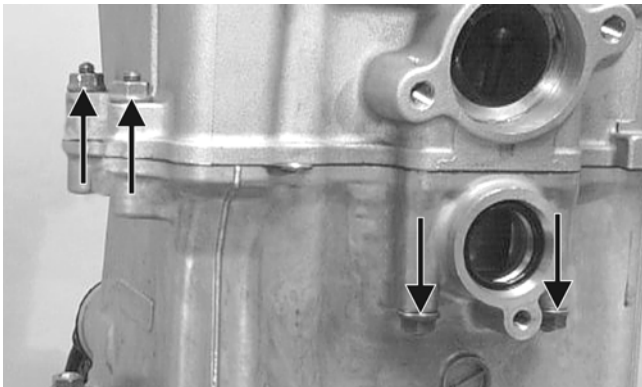

CC018D

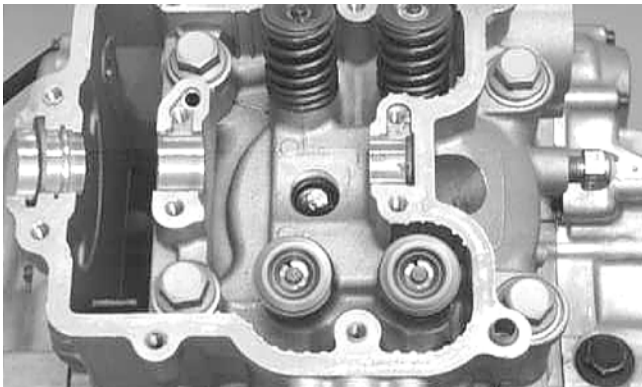

CC016D

- Remove the cylinder head from the cylinder, remove the gasket, and account for two alignment pins; then remove the cam chain guide.

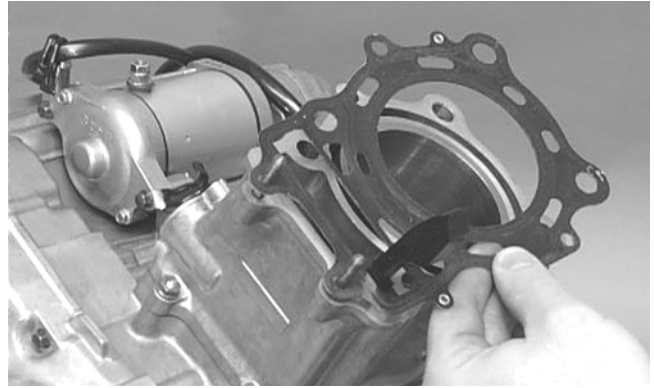

CC020D

AT THIS POINT

To service valves and cylinder head, see Servicing Top-Side Components sub-section.

AT THIS POINT

To inspect cam chain guide, see Servicing Top-Side Components sub-section.

3

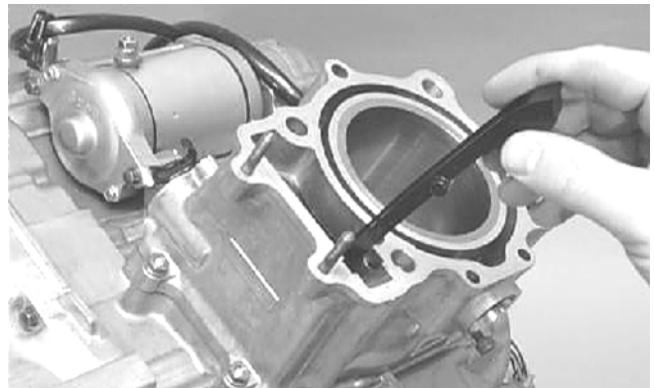

CC022D

**C. Cylinder
D. Piston**

■NOTE: Steps 1-9 in the preceding sub-section must precede this procedure.

- Loosen the clamp securing the coolant hose to the union; then detach the hose.
- Remove the two nuts securing the cylinder to the crankcase.

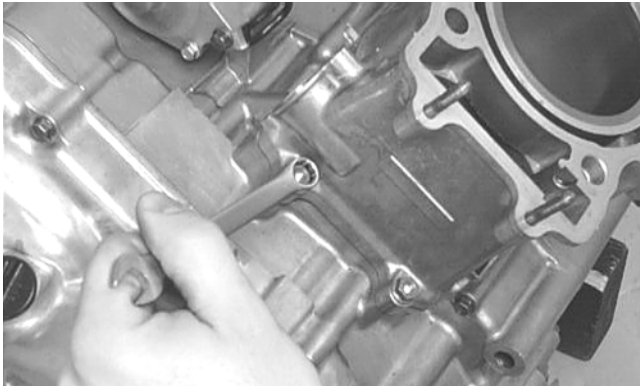

CC023D

12. Lift the cylinder off the crankcase taking care not to allow the piston to drop against the crankcase. Account for the gasket and two alignment pins.

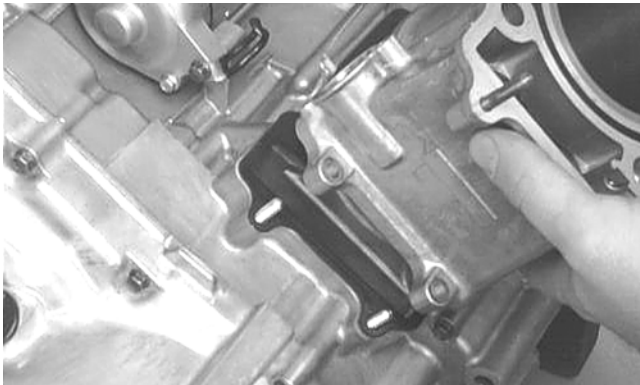

CC024D

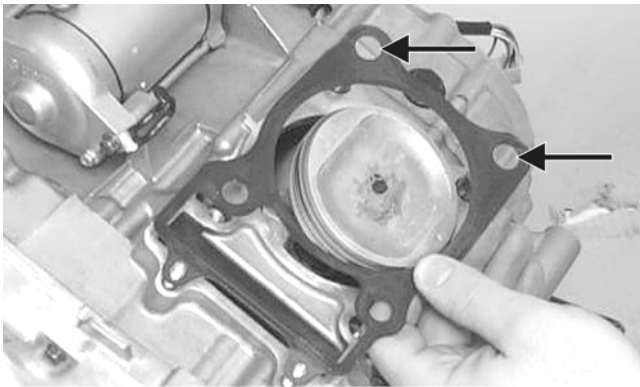

CC025D

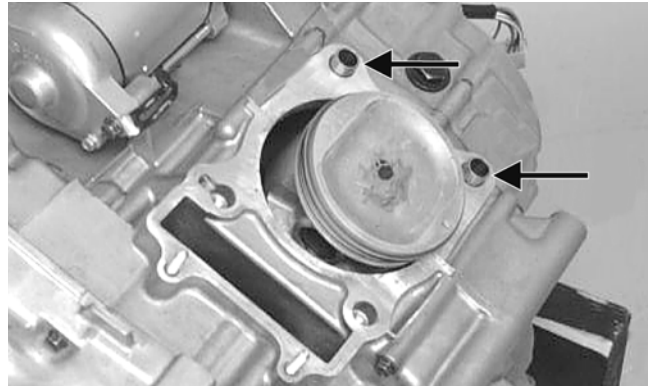

CC026D

AT THIS POINT

To service cylinder, see Servicing Top-Side Components sub-section.

CAUTION

When removing the cylinder, be sure to support the piston to prevent damage to the crankcase and piston.

13. Using an awl, remove one piston-pin circlip.

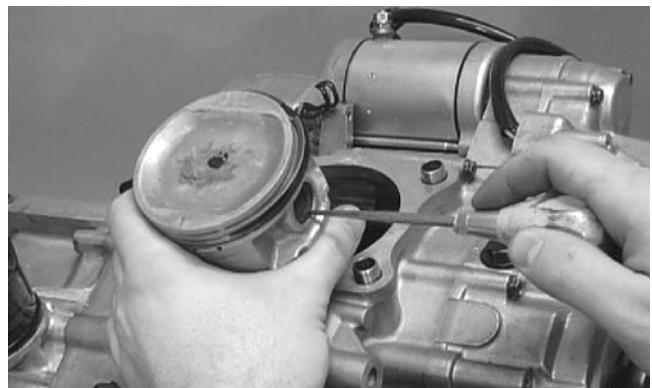

CC032D

14. Using the Piston Pin Puller, remove the piston pin. Account for the opposite-side circlip. Remove the piston.

■NOTE: It is advisable to remove the opposite-side circlip prior to using the puller.

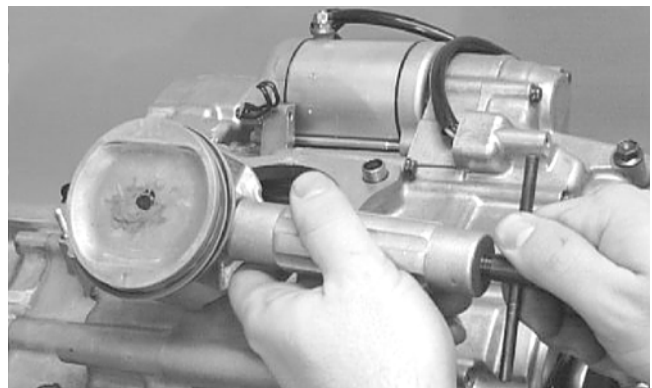

CC033D

■NOTE: Support the connecting rod with rubber bands to avoid damaging the rod or install a suitable connecting rod holder.

CAUTION

Do not allow the connecting rod to go down inside the crankcase. If the rod is down inside the crankcase and the crankshaft is rotated, severe damage will result.

AT THIS POINT

To service piston, see Servicing Top-Side Components sub-section.

AT THIS POINT

To service center crankcase components only, proceed to Removing Left-Side Components.

Servicing Top-Side Components

■NOTE: Whenever a part is worn excessively, cracked, or damaged in any way, replacement is necessary.

VALVE ASSEMBLY

When servicing valve assembly, inspect valve seats, valve stems, valve faces, and valve stem ends for pits, burn marks, or other signs of abnormal wear.

■NOTE: Whenever a valve is out of tolerance, it must be replaced.

Cleaning/Inspecting Valve Cover

■NOTE: If the valve cover cannot be trued, the cylinder head assembly must be replaced.

1. Wash the valve cover in parts-cleaning solvent.
2. Place the valve cover on the Surface Plate covered with #400 grit wet-or-dry sandpaper. Using light pressure, move the valve cover in a figure eight motion. Inspect the sealing surface for any indication of high spots. A high spot can be noted by a bright metallic finish. Correct any high spots before assembly by continuing to move the valve cover in a figure eight motion until a uniform bright metallic finish is attained.

CAUTION

Do not remove an excessive amount of the sealing surface or damage to the camshaft will result. Always check camshaft clearance when resurfacing the valve cover.

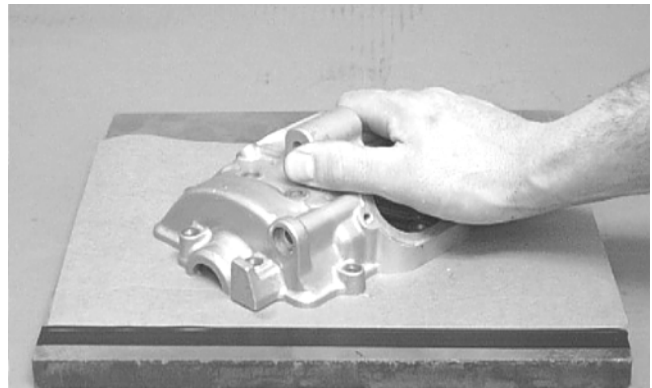

CC130D

CAUTION

Water or parts-cleaning solvent must be used in conjunction with the wet-or-dry sandpaper or damage to the sealing surface may result.

Removing Valves

■NOTE: Keep all valves and valve components as a set. Note the original location of each valve set for use during installation. Return each valve set to its original location during installation.

3

1. Using a valve spring compressor, compress the valve springs and remove the valve cotters. Account for an upper spring retainer.

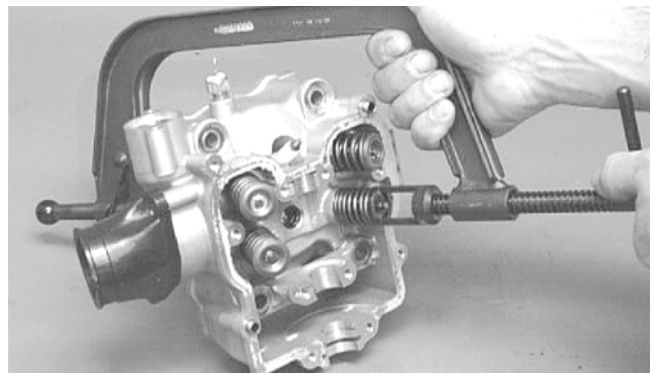

CC132D

2. Remove the valve seal and the lower remaining spring seat. Discard the valve seal.

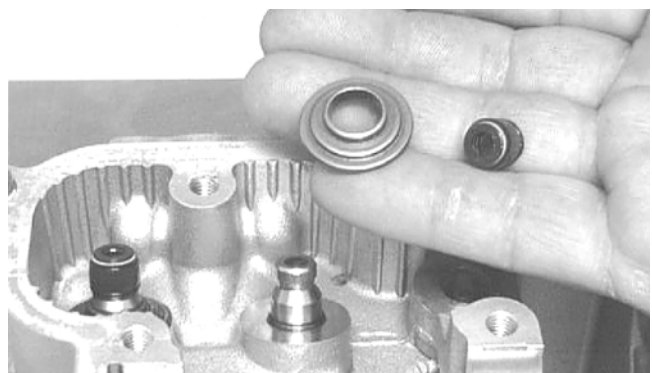

CC136D

■NOTE: The valve seals must be replaced.

- Remove the valve springs; then invert the cylinder head and remove the valves.

Measuring Valve Stem Runout

- Support each valve stem end with the V Blocks; then check the valve stem runout using a dial indicator.

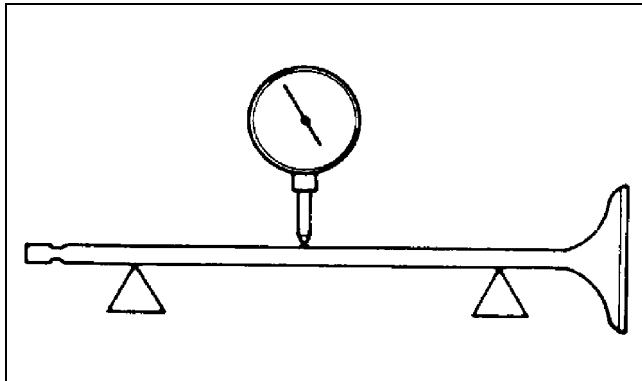

ATV-1082

- Maximum runout must not exceed specifications.

Measuring Valve Stem Outside Diameter

- Using a micrometer, measure the valve stem outside diameter.
- Acceptable diameter range (intake valve) must be within specifications.
- Acceptable diameter range (exhaust valve) must be within specifications.

Measuring Valve Face/Seat Width

- Using a micrometer, measure the width of the valve face.

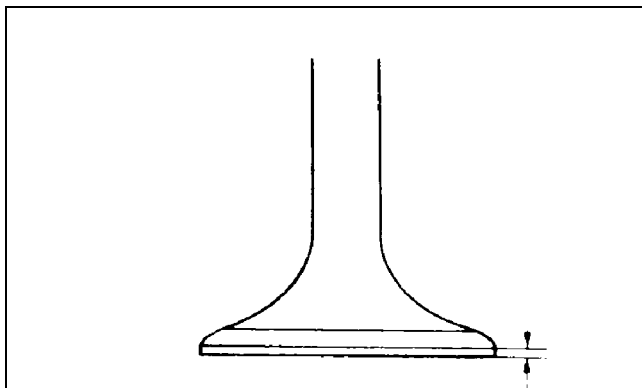

ATV-1004

- Acceptable width range must be within specifications.

Measuring Valve Face Radial Runout

- Mount a dial indicator on the surface plate; then place the valve stem on a set of V blocks.
- Position the dial indicator contact point on the outside edge of the valve face; then zero the indicator.

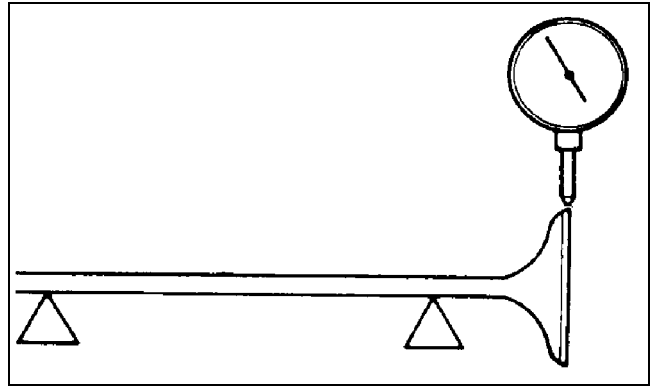

ATV1082A

- Rotate the valve in the V blocks.
- Maximum runout must not exceed specifications.

Measuring Valve Guide/Valve Stem Deflection (Wobble Method)

- Mount a dial indicator and base on the surface plate; then place the cylinder head on the surface plate.
- Install the valve into the cylinder head; then position the dial indicator contact point against the outside edge of the valve face. Zero the indicator.

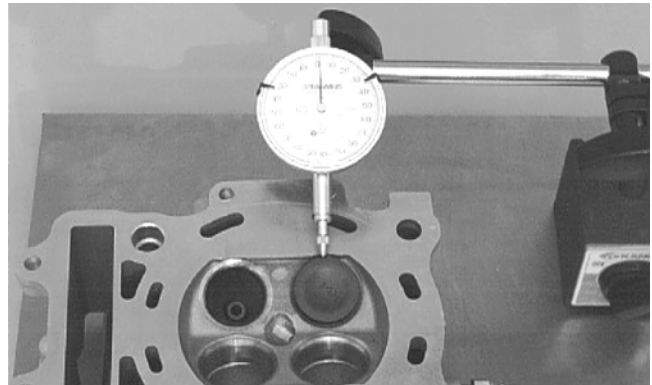

CC131D

- Push the valve from side to side; then from top to bottom.
- Maximum "wobble" deflection must not exceed specifications.

Measuring Valve Guide (Inside Diameter)

- Insert a suitable bore gauge 1/2 way into each valve guide bore and record the measurement.
- Acceptable inside diameter range must be within specifications.
- If a valve guide is out of tolerance, it must be replaced.

Servicing Valves/Valve Guides/Valve Seats

If valves, valve guides, or valve seats require servicing or replacement, Arctic Cat recommends the components be taken to a qualified machine shop for servicing.

CAUTION

If valves are discolored or pitted or if the seating surface is worn, the valve must be replaced. Do not attempt to grind the valves or severe engine damage may occur.

Measuring Rocker Arm (Inside Diameter)

1. Using a dial calipers, measure the inside diameter of the rocker arm.
2. Acceptable inside diameter must not exceed specification.

Measuring Rocker Arm Shaft (Outside Diameter)

1. Using a micrometer, measure the outside diameter of the rocker arm shaft.
2. Acceptable outside diameter must be at or above specification.

Installing Valves

1. Apply grease to the inside surface of the valve seals; then place a lower spring seat and valve guide seal over each valve guide.

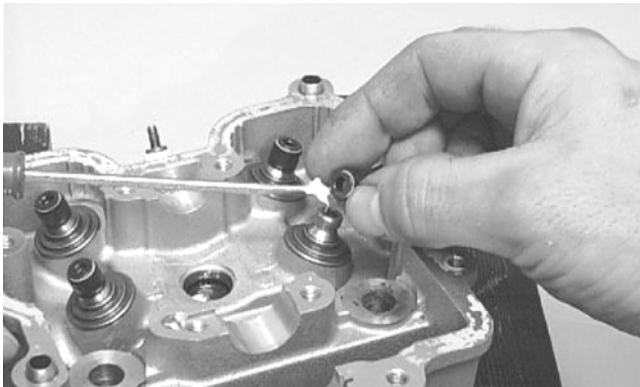

CC144D

2. Insert each valve into its original location.
3. Install the valve springs with the painted end of the spring facing away from the cylinder head.

■NOTE: If the paint is not visible, install the ends of the springs with the closest wound coils toward the head.

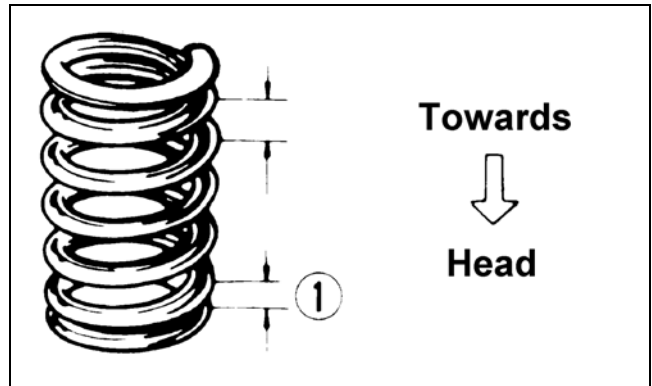

ATV-1011A

4. Place a spring retainer over the valve springs; then using the valve spring compressor, compress the valve springs and install the valve cotteners.

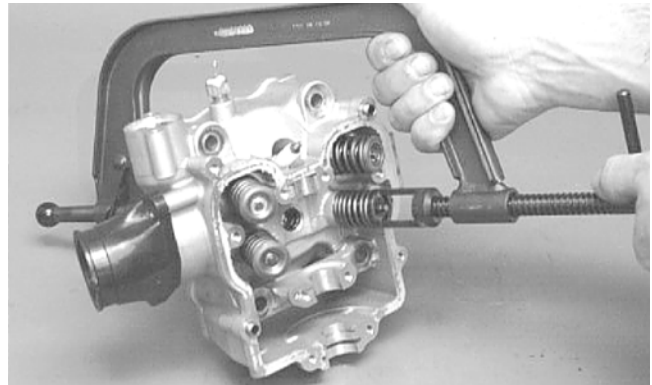

CC132D

3

PISTON ASSEMBLY

■NOTE: Whenever a piston or pin is out of tolerance, it must be replaced.

Removing Piston Rings

1. Starting with the top ring, slide one end of the ring out of the ring-groove.
2. Remove each ring by working it toward the dome of the piston while rotating it out of the groove.



CC400D

Cleaning/Inspecting Piston

1. Take an old piston ring and snap it into two pieces; then grind the end of the old ring to a 45° angle and to a sharp edge.

- Using the sharpened ring as a tool, clean carbon from the ring-grooves. Be sure to position the ring with its tapered side up.

CAUTION

Improper cleaning of the ring-grooves by the use of the wrong type of ring-groove cleaner will result in severe damage to the piston.

- Using a non-metallic carbon removal tool, remove any carbon buildup from the dome of the piston.
- Inspect the piston for cracks in the piston pin, dome, and skirt areas.
- Inspect the piston for seizure marks or scuffing.
- Inspect the perimeter of each piston for signs of excessive “blowby.” Excessive “blowby” indicates worn piston rings or an out-of-round cylinder.

Measuring Piston-Ring End Gap (Installed)

- Place each compression ring in the wear portion of the cylinder. Use the piston to position each ring squarely in the cylinder.
- Using a feeler gauge, measure each piston-ring end gap. Acceptable ring end gap must be within specifications.

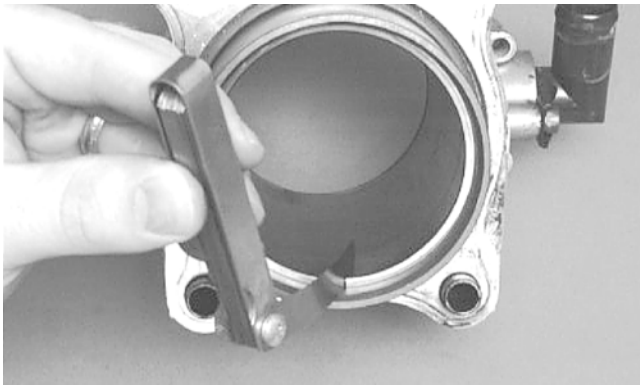

CC280D

Measuring Piston Pin (Outside Diameter) and Piston-Pin Bore

- Measure the piston pin outside diameter at each end and in the center. If measurement is not within specifications, the piston pin must be replaced.

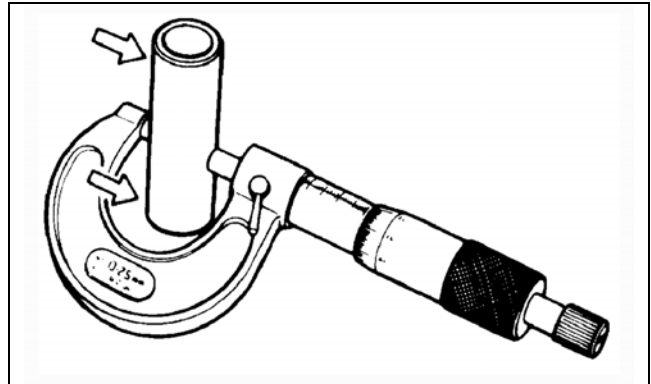

ATV-1070

- Insert an inside dial indicator into the piston-pin bore. The diameter must not exceed specifications. Take two measurements to ensure accuracy.

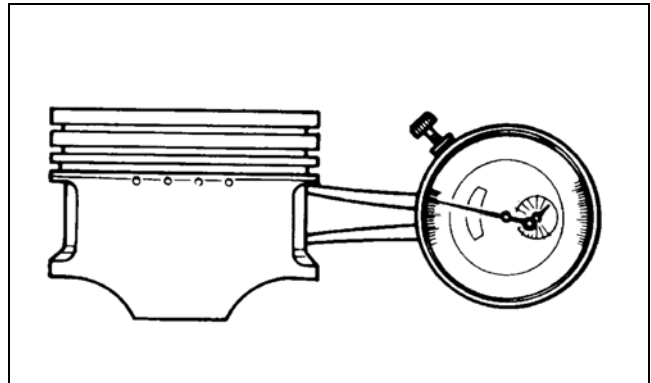

ATV-1069

Measuring Piston Skirt/ Cylinder Clearance

- Measure the cylinder front to back in six places.

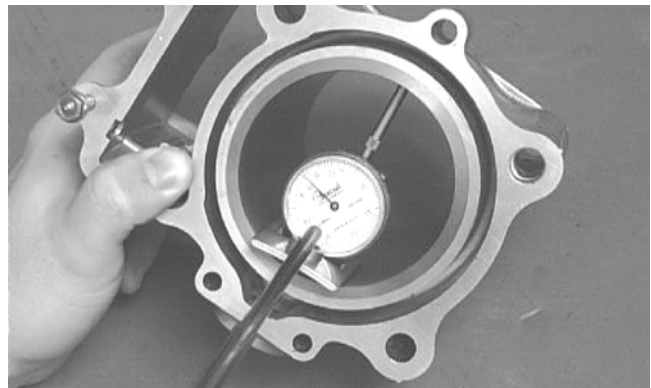

CC127D

- Measure the corresponding piston diameter at a point 15 mm above the piston skirt at a right angle to the piston-pin bore. Subtract this measurement from the measurement in step 1. The difference (clearance) must be within specifications.

Installing Piston Rings

- Install ring expander (4) in the bottom groove of the piston; then install the thin oil rings (3) over the expander making sure the expander ends do not overlap. Stagger the end gaps of the upper and lower thin oil rings according to the illustration.

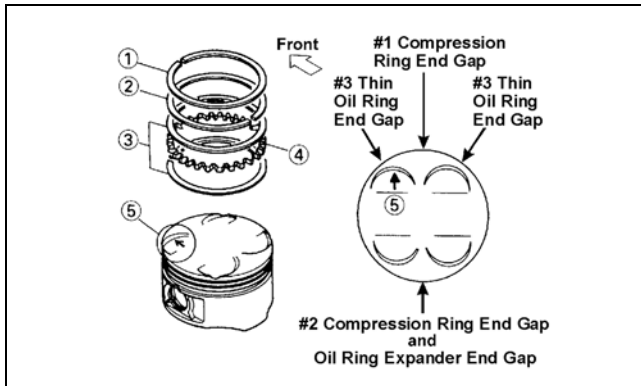

ATV-1085B

■NOTE: Note the direction of the exhaust side of the piston (5) for correct ring end gap orientation.

- The ring with the orientation mark (M TOP or TOP) should be installed in the second (middle) groove and the ring with the orientation mark (M or O) should be installed in the first (top) groove.

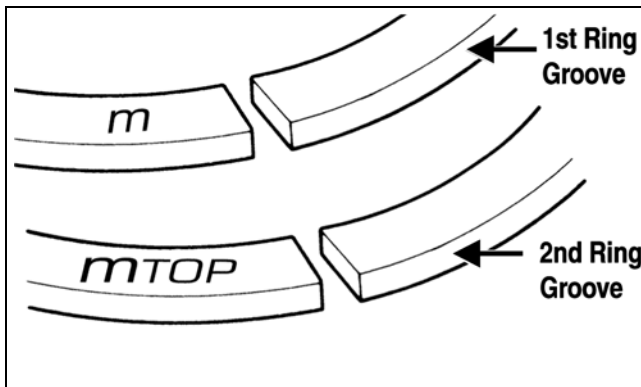

ATV-1024A

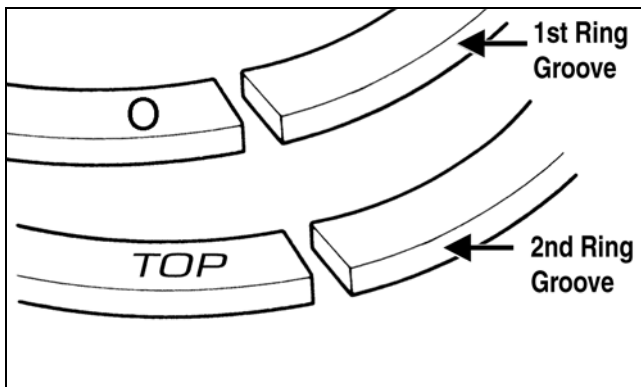

ATV-1024B

CAUTION

Incorrect installation of the piston rings will result in engine damage.

CYLINDER/CYLINDER HEAD ASSEMBLY

■NOTE: If the cylinder/cylinder head assembly cannot be trued, they must be replaced.

Cleaning/Inspecting Cylinder Head

CAUTION

The cylinder head studs must be removed for this procedure.

- Using a non-metallic carbon removal tool, remove any carbon buildup from the combustion chamber being careful not to nick, scrape, or damage the combustion chamber or the sealing surface.
- Inspect the spark plug hole for any damaged threads. Repair damaged threads using a “heli-coil” insert.
- Place the cylinder head on the surface plate covered with #400 grit wet-or-dry sandpaper. Using light pressure, move the cylinder head in a figure eight motion. Inspect the sealing surface for any indication of high spots. A high spot can be noted by a bright metallic finish. Correct any high spots before assembly by continuing to move the cylinder head in a figure eight motion until a uniform bright metallic finish is attained.

CAUTION

Water or parts-cleaning solvent must be used in conjunction with the wet-or-dry sandpaper or damage to the sealing surface may result.

3

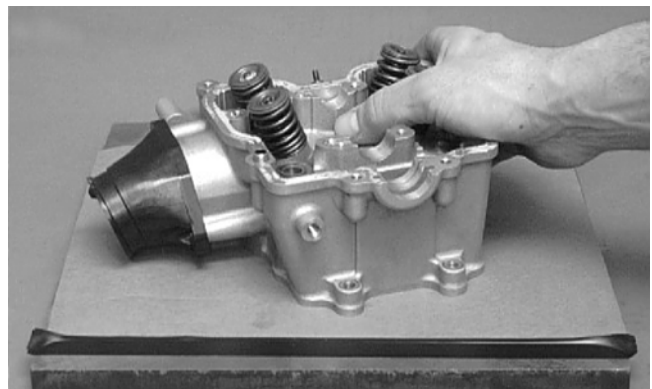

CC128D

Measuring Cylinder Head Distortion

- Remove any carbon buildup in the combustion chamber.
- Lay a straightedge across the cylinder head; then using a feeler gauge, check the distortion factor between the head and the straightedge.
- Maximum distortion must not exceed specifications.

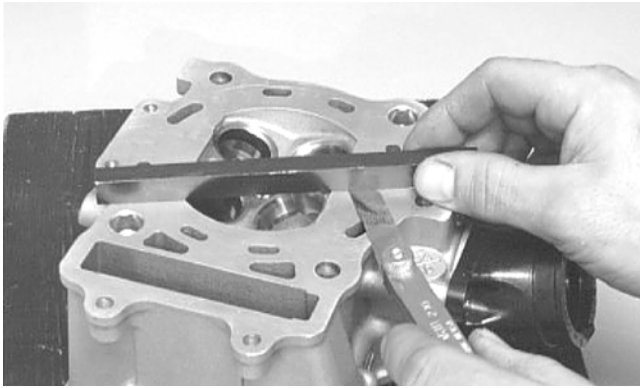

CC141D

Cleaning/Inspecting Cylinder

1. Wash the cylinder in parts-cleaning solvent.
2. Inspect the cylinder for pitting, scoring, scuffing, warpage, and corrosion. If marks are found, repair the surface using a cylinder hone (see Honing Cylinder in this sub-section).
3. Place the cylinder on the surface plate covered with #400 grit wet-or-dry sandpaper. Using light pressure, move the cylinder in a figure eight motion. Inspect the sealing surface for any indication of high spots. A high spot can be noted by a bright metallic finish. Correct any high spots before assembly by continuing to move the cylinder in a figure eight motion until a uniform bright metallic finish is attained.

CAUTION

Water or parts-cleaning solvent must be used in conjunction with the wet-or-dry sandpaper or damage to the sealing surface may result.

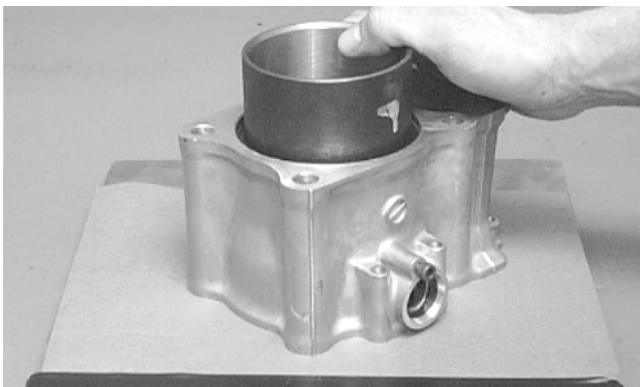

CC129D

Inspecting Cam Chain Guide

1. Inspect cam chain guide for cuts, tears, breaks, or chips.
2. If the chain guide is damaged, it must be replaced.

Honing Cylinder

1. Using a slide gauge and a dial indicator or a snap gauge, measure the cylinder bore diameter in three locations from top to bottom and again from top to bottom at 90° from the first measurements for a total of six measurements. The trueness (out-of-roundness) is the difference between the highest and lowest reading. Maximum trueness (out-of-roundness) must not exceed specifications.

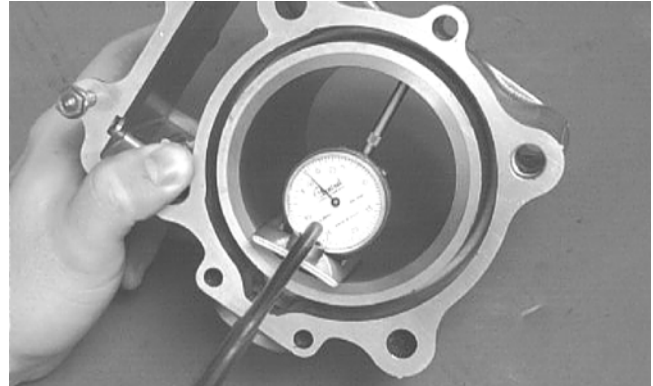

CC127D

2. Wash the cylinder in parts-cleaning solvent.
3. Inspect the cylinder for pitting, scoring, scuffing, and corrosion. If marks are found, repair the surface using a #320 grit ball hone.

■NOTE: To produce the proper 60° cross-hatch pattern, use a low RPM drill (600 RPM) at the rate of 30 strokes per minute. If honing oil is not available, use a lightweight petroleum-based oil. Thoroughly clean cylinder after honing using soap and hot water. Dry with compressed air; then immediately apply oil to the cylinder bore. If the bore is severely damaged or gouged, replace the cylinder.



CC390D

4. If any measurement exceeds the limit, replace the cylinder and piston.

Measuring Camshaft Runout

■NOTE: If the camshaft is out of tolerance, it must be replaced.

1. Place the camshaft on a set of V blocks; then position the dial indicator contact point against the shaft and zero the indicator.

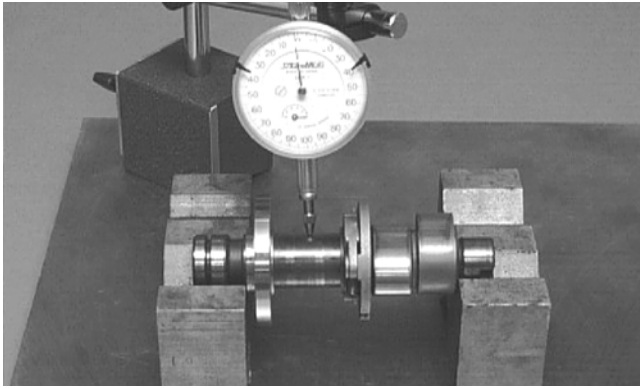

CC283D

2. Rotate the camshaft and note runout; maximum tolerance must not exceed specifications.

Measuring Camshaft Lobe Height

1. Using a calipers, measure each cam lobe height.

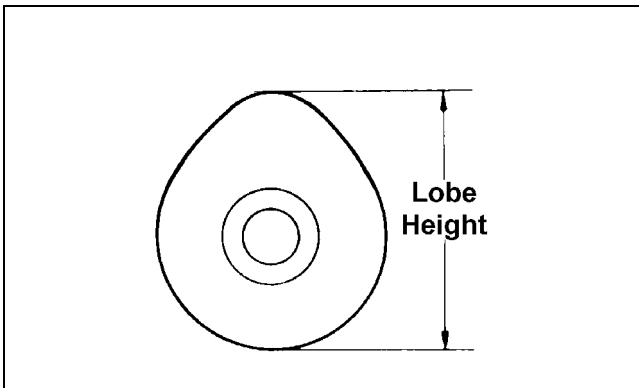

ATV1013A

2. The lobe heights must not exceed minimum specifications.

Inspecting Camshaft Bearing Journal

1. Inspect the bearing journal for scoring, seizure marks, or pitting.
2. If excessive scoring, seizure marks, or pitting is found, the cylinder head assembly must be replaced.

Measuring Camshaft to Cylinder Head Clearance

1. Remove the adjuster screws and jam nuts.

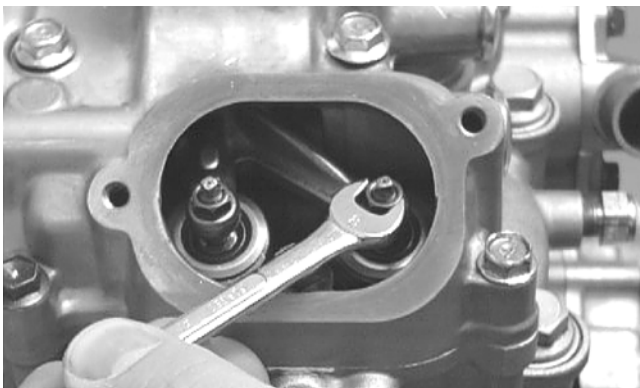

CC005D

2. Place a strip of plasti-gauge in each of the camshaft lands in the cylinder head.
3. Place the valve cover on the cylinder head and secure with the valve cover cap screws. Tighten securely.

■NOTE: Do not rotate the camshaft when measuring clearance.

4. Remove the cap screws securing the valve cover to the cylinder; then remove the valve cover and camshaft.

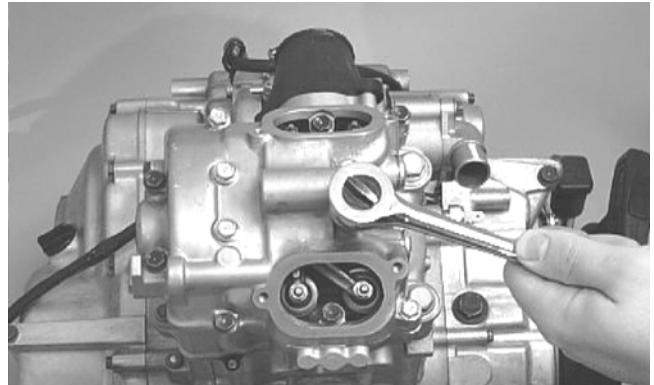

CC003D

5. Match the width of the plasti-gauge with the chart found on the plasti-gauge packaging to determine camshaft to cylinder head and valve cover clearance.

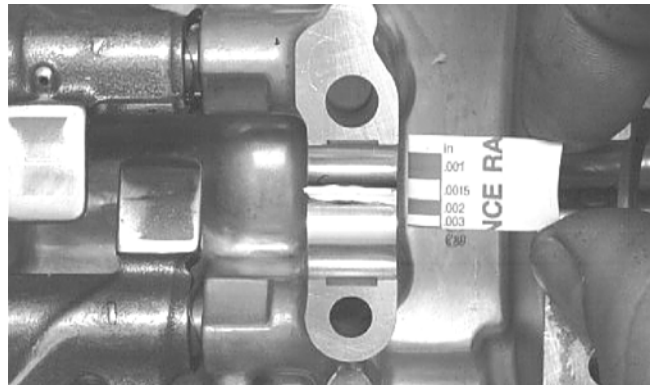

CC145D

6. If clearance is excessive, measure the journals of the camshaft.

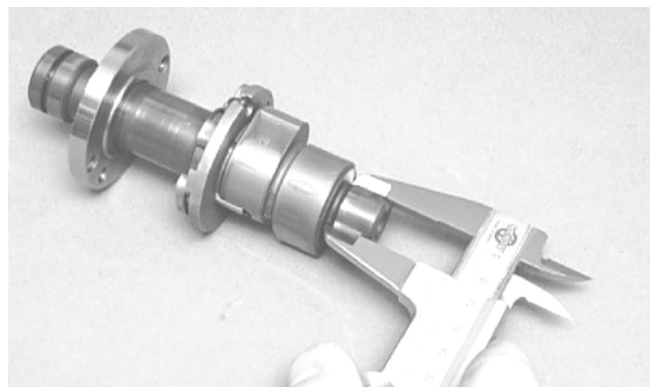

CC287D

■NOTE: If the journals are worn, replace the camshaft; then measure the clearance again. If it is still out of tolerance, replace the cylinder head.

Inspecting Camshaft Spring/Drive Pin

1. Inspect the spring and drive pin for damage.

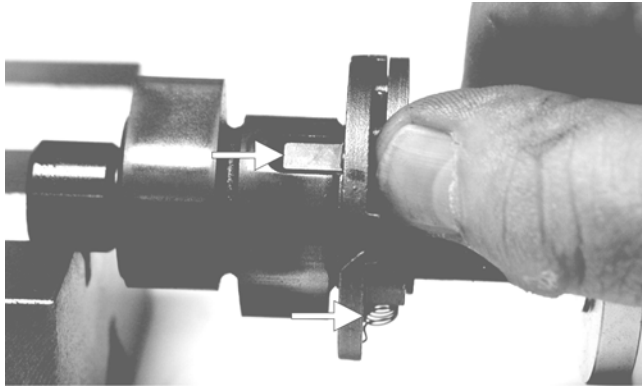

CF061A

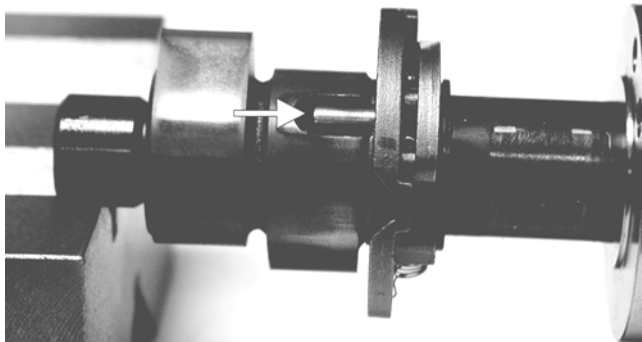

CF060A

2. If damaged, the camshaft must be replaced.

Installing Top-Side Components

- A. Piston
- B. Cylinder

KEY

1. Cylinder
2. Stud Bolt
3. Nut
4. Cylinder Gasket
5. Pin
6. Water Hose Union
7. Cap Screw
8. O-Ring

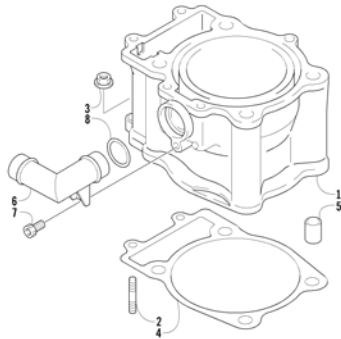

0732-301

1. Install the piston on the connecting rod making sure the circlip on each side is fully seated in the piston.

NOTE: The piston should be installed so the arrow points toward the exhaust.

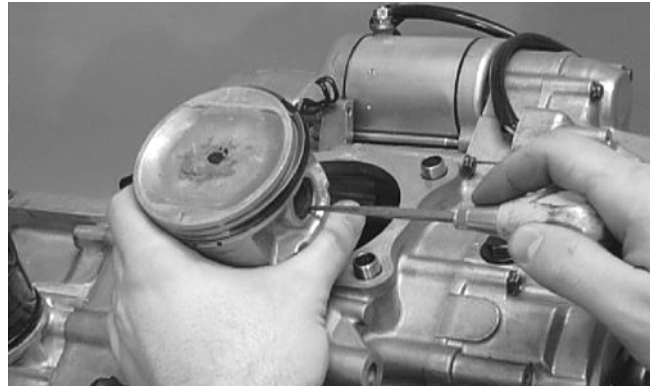

CC032D

2. Place the two alignment pins into position. Place the cylinder gasket into position; then place a piston holder (or suitable substitute) beneath the piston skirt and square the piston in respect to the crankcase.



CF083

3. Lubricate the inside wall of the cylinder; then using a ring compressor, compress the rings and slide the cylinder over the piston. Route the cam chain up through the cylinder cam chain housing; then remove the piston holder and seat the cylinder firmly on the crankcase.

CAUTION

The cylinder should slide on easily. Do not force the cylinder or damage to the piston, rings, cylinder, or crankshaft assembly may occur.



CC024D

4. Loosely install the two nuts which secure the cylinder to the crankcase.

NOTE: The two cylinder-to-crankcase nuts will be tightened in step 10.

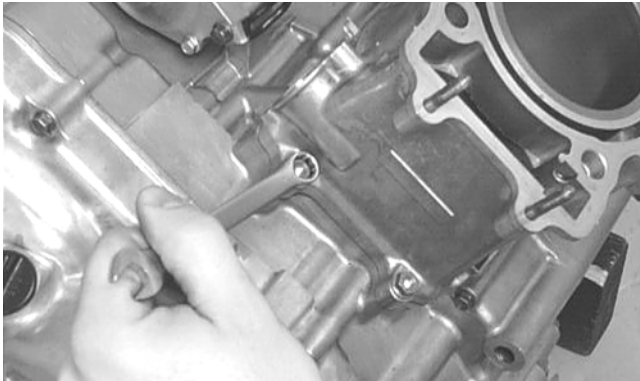

CC023D

5. Install the coolant hose onto the crankcase union and tighten the clamp.

C. Cylinder Head

D. Valve Cover

■NOTE: Steps 1-5 in the preceding sub-section must precede this procedure.

6. Place the chain guide into the cylinder.

CAUTION

Care should be taken that the bottom of the chain guide is secured in the crankcase boss.

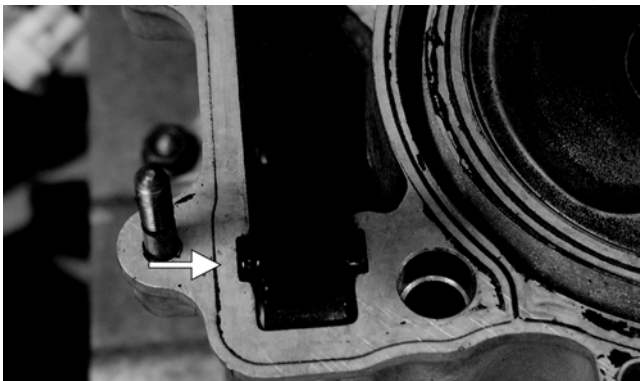

CF058A

7. Place the head gasket into position on the cylinder. Place the alignment pins into position; then place the head assembly into position on the cylinder.

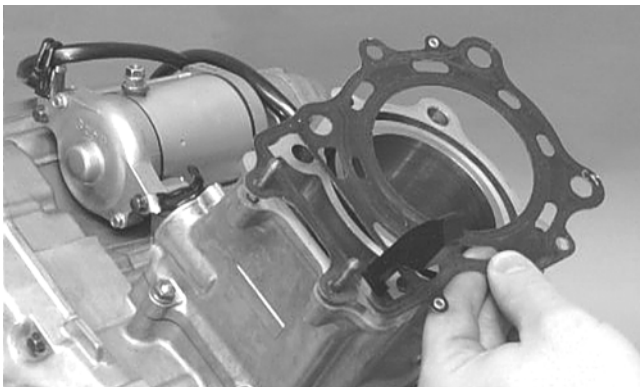

CC020D

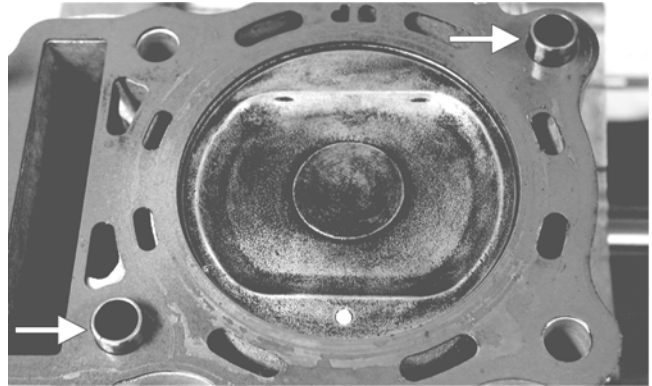

CF057A

8. Install the four cylinder head cap screws. Tighten only until snug.

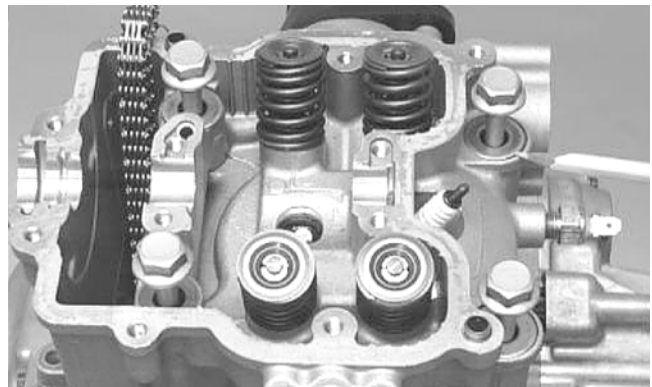

CC272D

9. Loosely install the five cylinder head nuts.
10. In a crisscross pattern, tighten the four cylinder head cap screws (from step 8) in 10 ft-lb increments to 40 ft-lb; then tighten the 8 mm nut (from step 9) to 18 ft-lb. Using a crisscross pattern, tighten the 6 mm nuts (from step 9) to 8 ft-lb. Tighten the two cylinder-to-crankcase nuts (from step 4) securely.
11. With the timing inspection plug removed and the chain held tight, rotate the crankshaft until the piston is at top-dead-center.
12. Install the rear cam chain tensioner guide into the cylinder head. Install the pivot cap screw and washer.

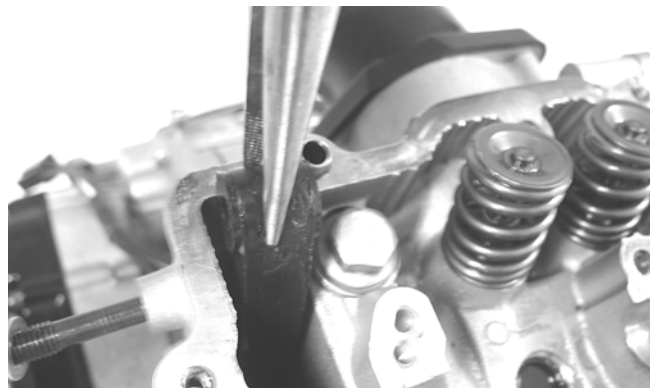

CD461

13. With the alignment pin installed in the camshaft, loosely place the cam sprocket (with the recessed side facing the cam shaft lobes) onto the camshaft. At this point, do not "seat" the sprocket onto the shaft.

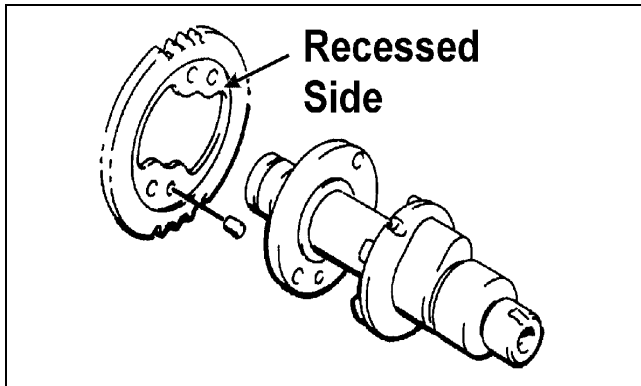

732-307B

■NOTE: At this point, oil the camshaft journals, cam lobes, and the three seating surfaces on the cylinder.

14. With the cam lobes directed down (toward the piston), maneuver the camshaft/sprocket assembly through the chain and towards its seating position; then loop the chain over the sprocket.

■NOTE: Note the position of the alignment marks on the end of the camshaft. They must be parallel with the valve cover mating surface. If rotating the camshaft is necessary for alignment, rotate the sprocket inside the chain until the alignment pin can be engaged in the sprocket with the camshaft properly aligned to the head.

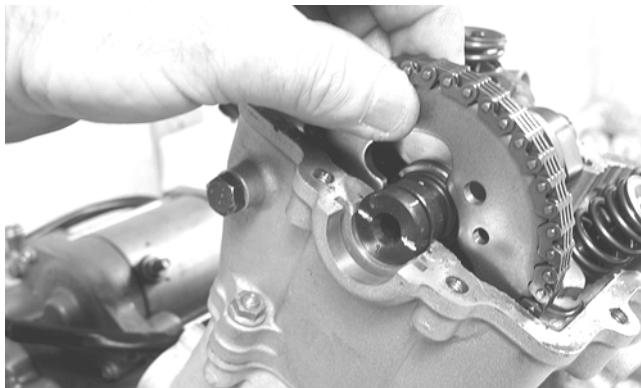

CD463

15. Seat the cam sprocket onto the camshaft making sure the alignment pin in the camshaft aligns with the smallest hole in the sprocket; then place the camshaft/sprocket assembly onto the cylinder ensuring the following.

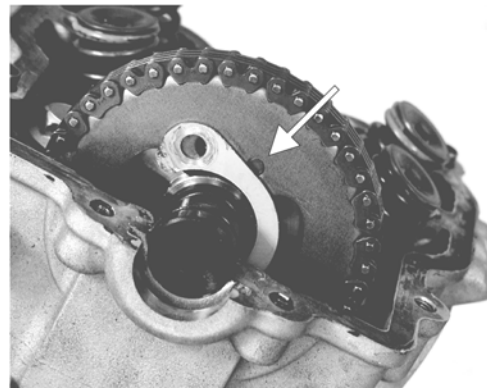

CF013A

- A. Piston still at top-dead-center.
- B. Camshaft lobes directed down (toward the piston).
- C. Camshaft alignment marks parallel to the valve cover mating surface.
- D. Recessed side of the sprocket directed toward the cam lobes.
- E. Camshaft alignment pin and sprocket alignment hole (smallest) are aligned.

CAUTION

If any of the above factors are not as stated, go back to step 11 and carefully proceed.

16. Place the tab-washer onto the sprocket making sure it covers the pin in the alignment hole.

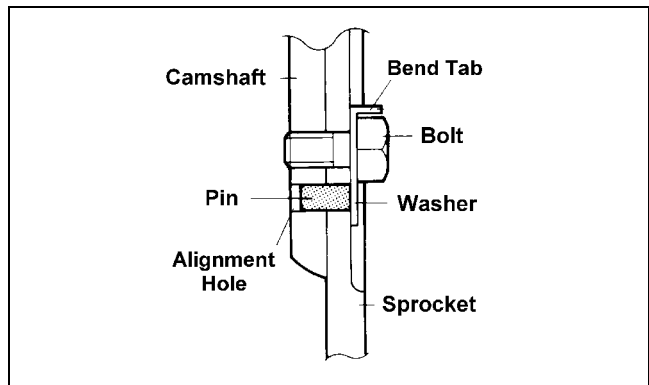

ATV1027

CAUTION

Care must be taken that the tab-washer is installed correctly to cover the alignment hole on the sprocket. If the alignment pin falls out, severe engine damage will result.

17. Install the first cap screw (threads coated with red Loctite #271) securing the sprocket and tab-washer to the camshaft. Tighten only until snug.

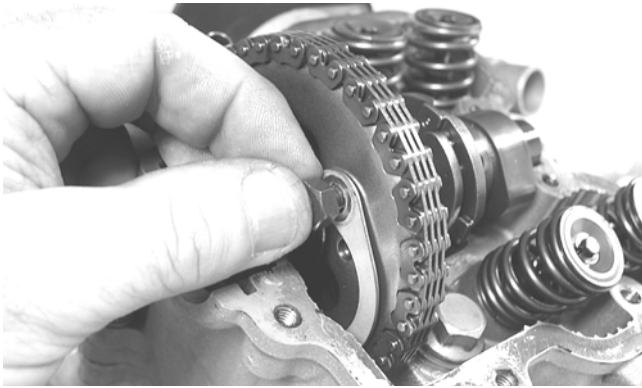

CD464

18. Rotate the crankshaft until the second cap screw securing the sprocket to the camshaft can be installed; then install the cap screw (threads coated with red Loctite #271) and tighten to 11 ft-lb. Bend the tab to secure the cap screw.

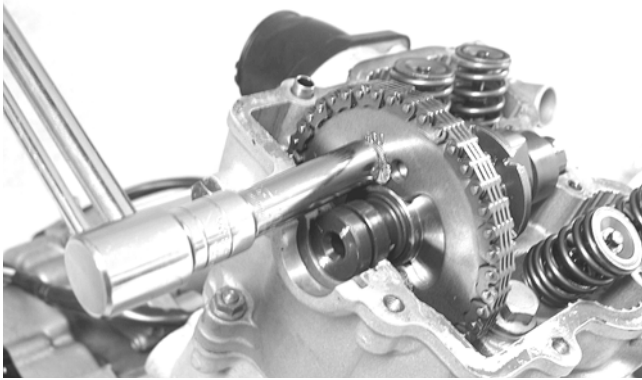

CD465

19. Rotate the crankshaft until the first cap screw (from step 17) can be addressed; then tighten to 11 ft-lb. Bend the tab to secure the cap screw.

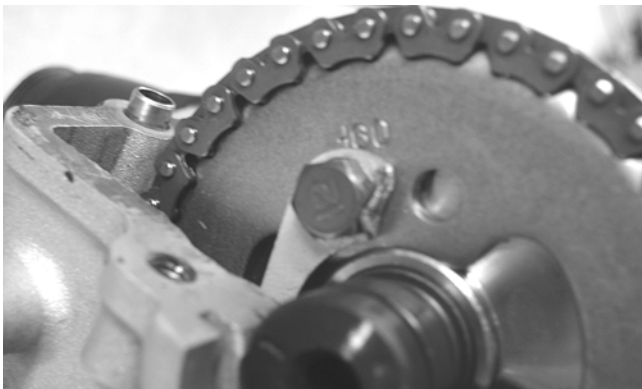

CD466

20. Place the C-ring into position in its groove in the cylinder head.

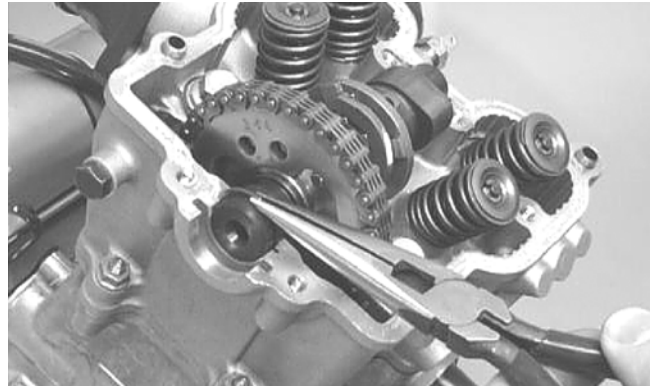

CC012D

21. Install the cylinder head plug in the cylinder head with the open end facing downward and toward the inside.

CAUTION

The open end of the plug must be positioned downward.

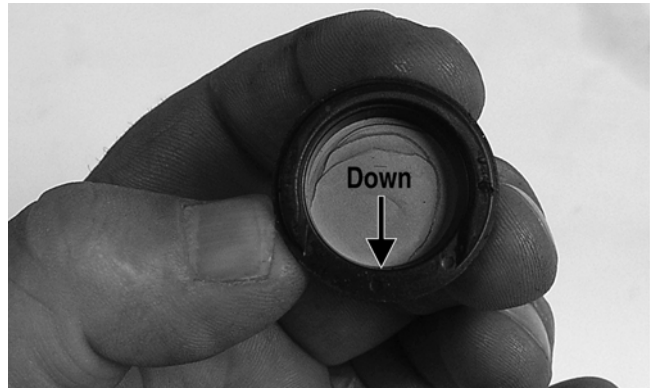

GZ162A

22. Remove the cap screw from the end of the chain tensioner; then using a flat-blade screwdriver, rotate the adjuster screw inside the tensioner clockwise until the screw bottoms.

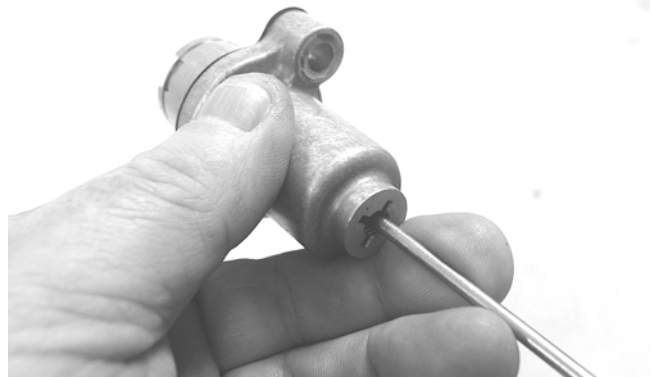

CD501

■NOTE: The adjuster shaft will be drawn into the tensioner as the adjuster screw is rotated clockwise. The adjuster shaft tension will be released in step 24.

23. Place the chain tensioner adjuster assembly and gasket into position on the cylinder and secure with the two cap screws.

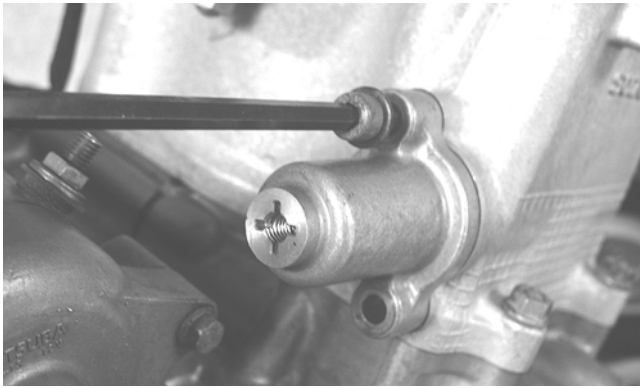

CD469

24. Using a flat-blade screwdriver, rotate the adjuster screw inside the tensioner counterclockwise until all tension is released; then install the cap screw into the end of the chain tensioner.

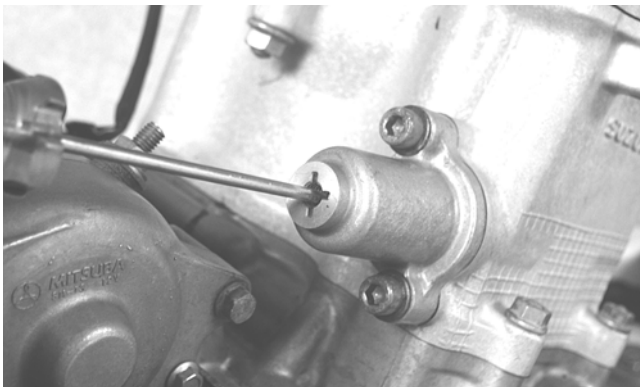

CD470

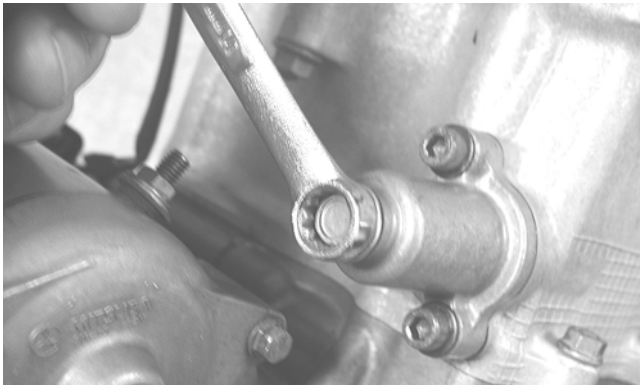

CD471

25. Loosen the four adjuster screw jam nuts; then loosen the four adjuster screws on the rocker arms in the valve cover.

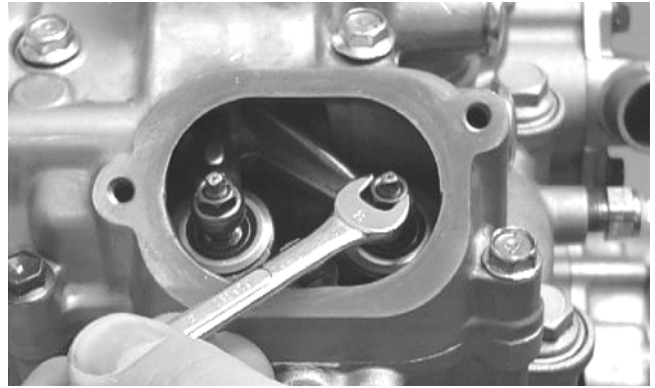

CC005D

26. Apply a thin coat of Three Bond Sealant to the mating surfaces of the cylinder head and valve cover.



CC275D

27. Place the valve cover into position.

■NOTE: At this point, the rocker arms and adjuster screws must not have pressure on them.

28. Install the four top side cap screws with rubber washers; then install the remaining cap screws. Tighten only until snug.

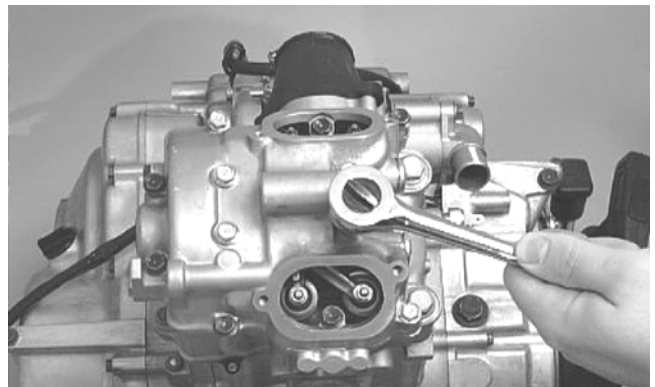

CC003D

29. In a crisscross pattern starting from the center and working outward, tighten the cap screws (from step 28) to 8.5 ft-lb.

30. Adjust valve/tappet clearance (see Section 2).

31. Place the two tappet covers into position making sure the proper cap screws are with the proper cover. Tighten the cap screws to 9 ft-lb.



CC001D

32. If removed, install the spark plug. Tighten securely.

Left-Side Components

■NOTE: For efficiency, it is preferable to remove and disassemble only those components which need to be addressed and to service only those components. The technician should use discretion and sound judgment.

 **AT THIS POINT**

To service any one specific component, only limited disassembly of components may be necessary. Note the AT THIS POINT information in each sub-section.

■NOTE: The engine/transmission does not have to be removed from the frame for this procedure.

Removing Left-Side Components

- A. Water Pump**
- B. Side Cover**
- C. Rotor/Flywheel**

1. Remove the four screws securing the outer magneto cover to the side cover; then remove the cover. Account for the gasket.
2. Remove the flange nut securing the spacer to the crankshaft; then remove the spacer. Account for the O-ring.

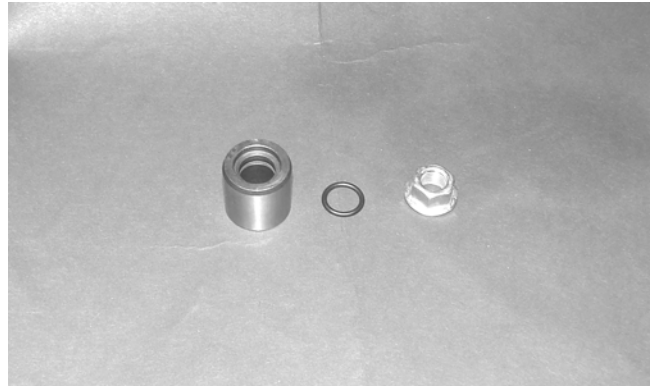

PR465

3. Using a cold chisel, scribe a mark showing the relative position of the shift arm to the shift arm shaft to aid in installing; then remove the shift arm.



PR429A

4. Remove the two cap screws securing the speed sensor housing; then remove the housing. Account for the gasket and two seal washers.

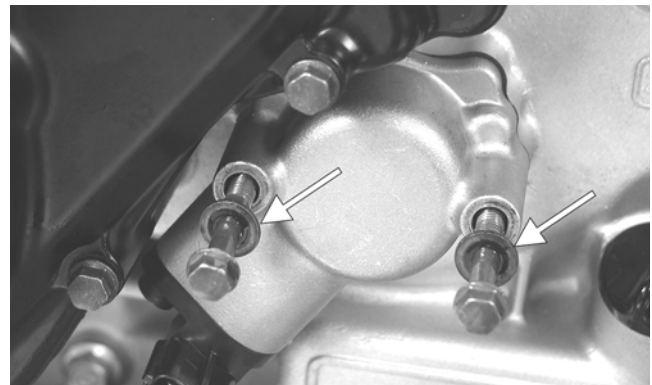

CD920A

5. Loosen the clamps securing the coolant hose to the water pump; then remove the crossover tube from the cylinder head. Account for an O-ring.

3

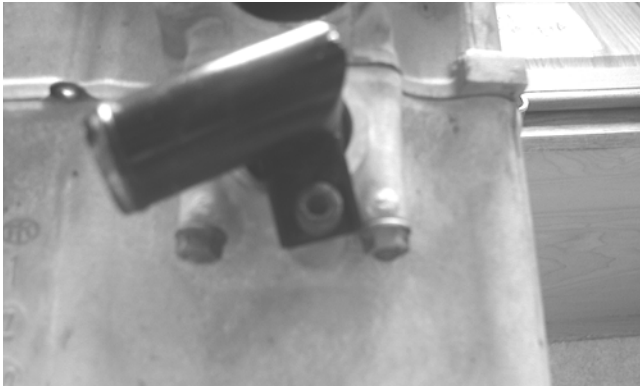

CD214

6. Remove the two cap screws securing the water pump to the engine; then remove the water pump.

■ **NOTE:** The water pump is not a serviceable component. If the pump is defective or if the mechanical seal is leaking (coolant dripping from the discharge hole), the water pump must be replaced (see Section 4).

7. Remove the cap screws securing the side cover to the crankcase noting the location of the different-sized cap screws for installing purposes.
8. Using a side case puller, remove the side cover. Account for a gasket and two alignment pins.

■ **NOTE:** Inspect the inside of the right-side cover for any shaft washers that may have come off with the cover. Make sure they are returned to their respective shafts and the starter idler gear spacer is on the shaft or in the cover.

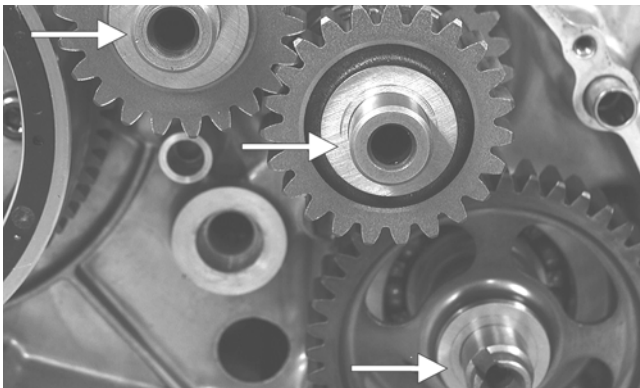

CF075A

9. Remove the nut securing the magneto rotor to the crankshaft; then install the magneto rotor puller adapter.

■ **NOTE:** The puller has left-hand threads.

10. Using Magneto Rotor Remover Set with appropriate crankshaft protector, remove the rotor/flywheel assembly from the crankshaft. Account for the key; then remove the starter clutch gear assembly and washer.

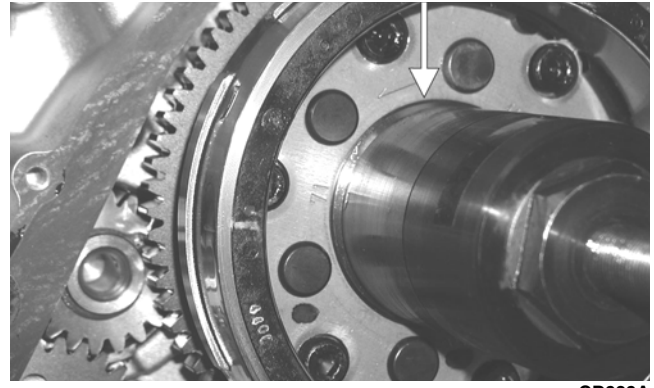

CD939A

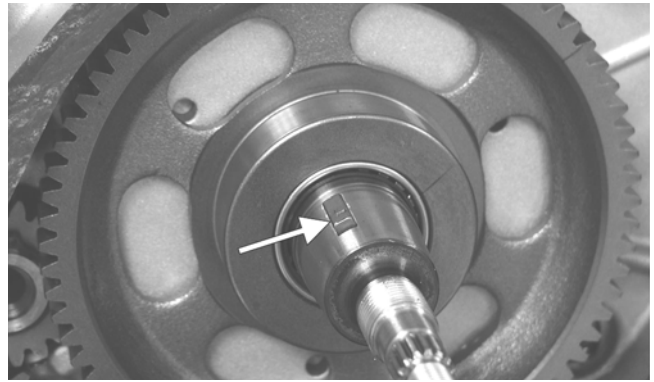

CD940A

11. Remove the two starter gears from the crankcase noting the direction of the beveled side of the gears for installing purposes; then remove the two starter gear shafts.

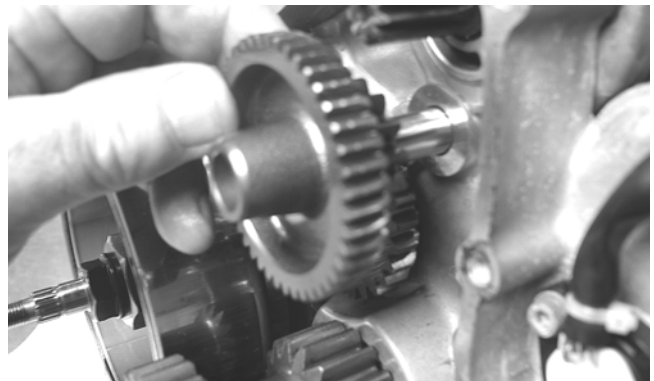

CD136

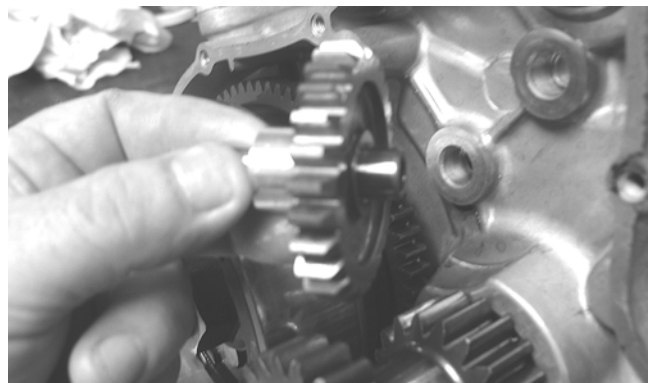

CD140

- Remove the snap ring securing the water pump drive gear; then remove the gear noting the direction of the sides of the gear for installing purposes. Account for the drive gear alignment pin.



CD944

- Remove the snap ring securing the water pump driven gear; then remove the gear noting the direction of the sides of the gear for installing purposes. Account for the driven gear alignment pin.

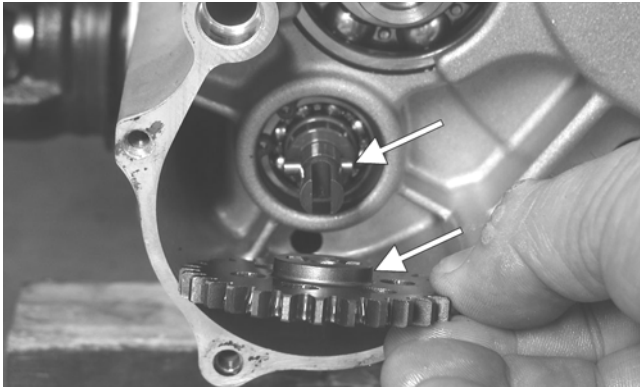

CD952A

■NOTE: There is an oil passage beneath the driven gear/drive gear assembly. This passage should be plugged prior to removing the driven gear and drive gear. Failure to do so could result in the loss of an alignment pin into the crankcase.

- Remove the shift shaft noting the timing marks for assembling purposes. Account for two washers.

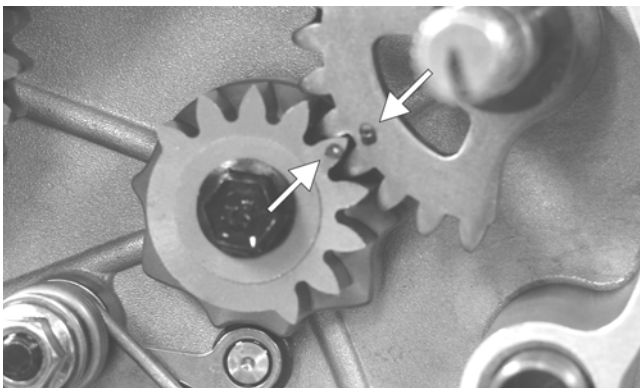

PR430A

- Remove the gear shift cam plate; then remove the shift cam stopper and cam stopper spring. Account for two washers.

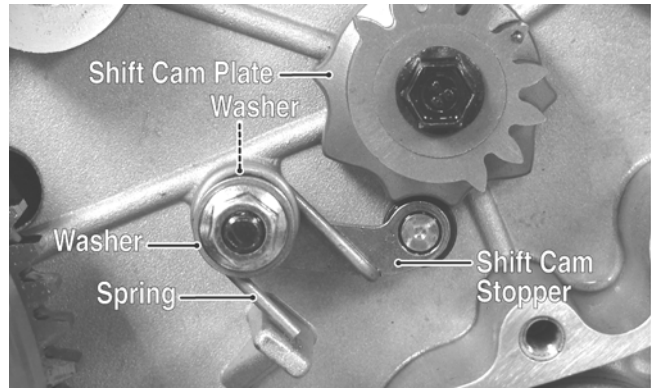

PR434A

Installing Left-Side Components

■NOTE: Plug the oil passage in the crankcase housing prior to installing the drive gear/driven gear assembly to prevent loss of an alignment pin.

3

- Install the water pump driven gear alignment pin and the driven gear (with the beveled side of the gear facing outward as noted in removing); then secure with the snap ring.

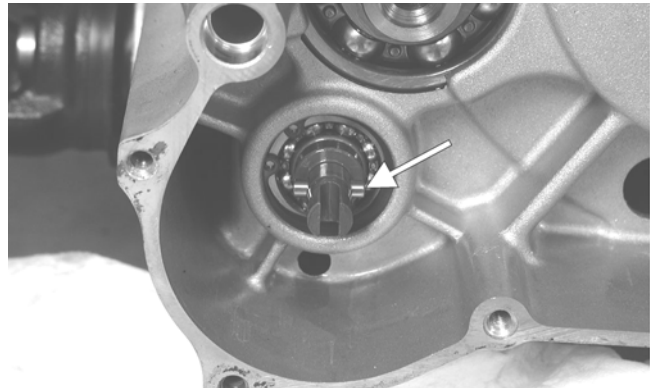

CD950A

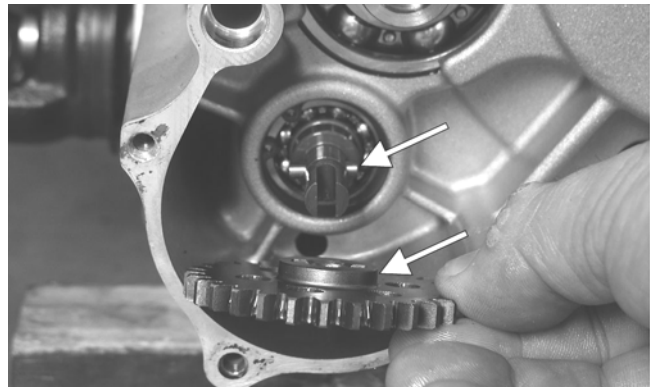

CD952A

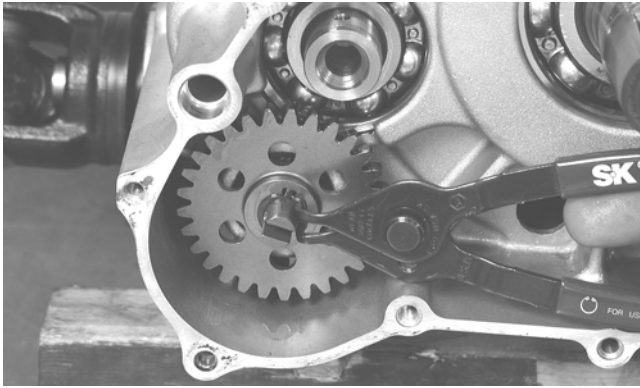

CD949

■NOTE: The sharp side of the snap ring should be facing outward.

2. Install the water pump drive gear drive pin and the drive gear (with the flat side of the gear facing outward as noted in removing); then secure with the snap ring.

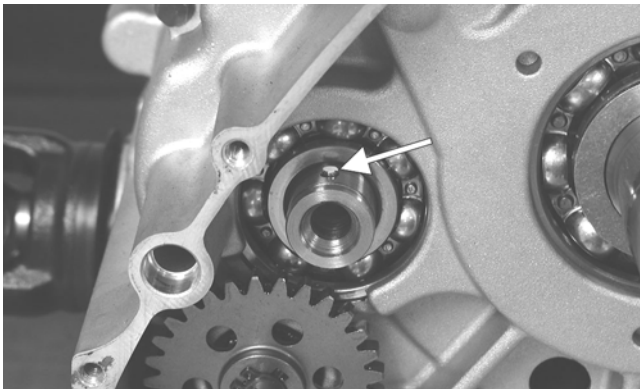

CD946A



CD944

■NOTE: The sharp side of the snap ring should be facing outward.

■NOTE: Once the gears are secured, remove the oil passage plug from the crankcase.

3. Install the two starter gear shafts; then install the two starter gears (with the beveled side of the intermediate gear facing inward as noted in removing).

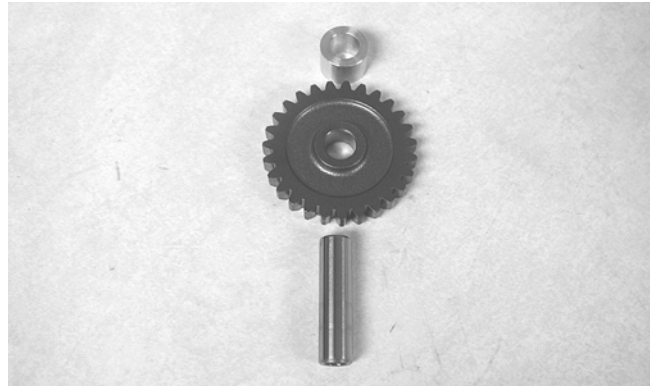

CD139

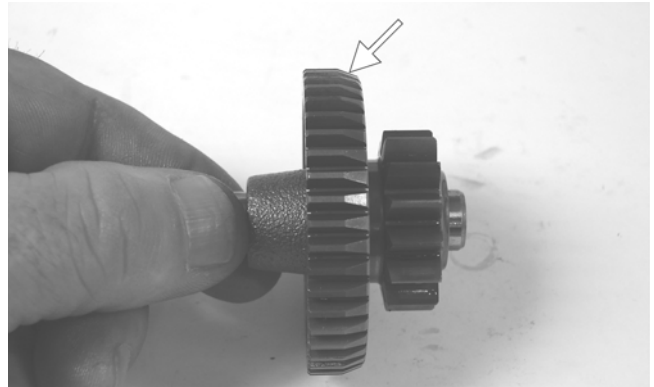

PR447A

4. In order on the crankshaft, install a washer, ring gear, key, and the magneto rotor. Secure with the nut (threads coated with red Loctite #271). Tighten to 105 ft-lb.

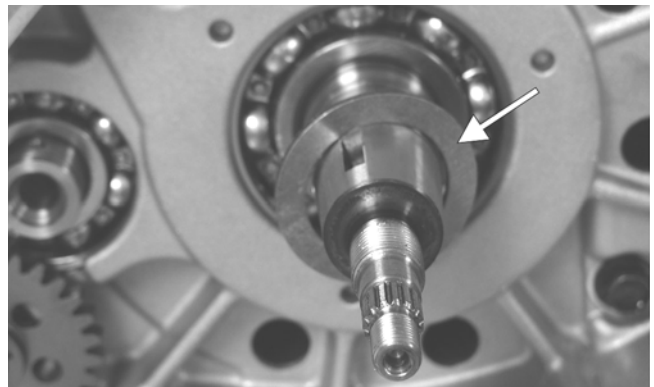

CD948A

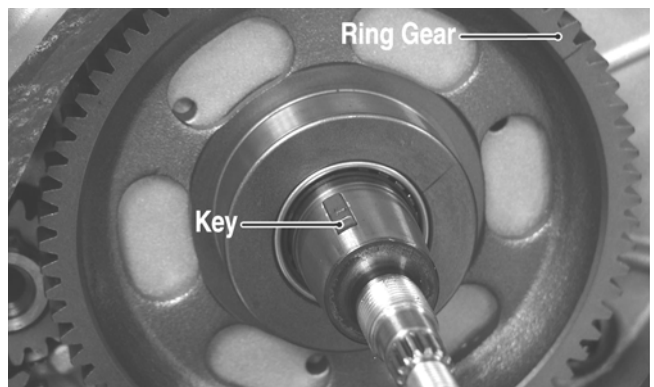

CD940B

5. Install the shift cam plate onto the shift cam shaft; then coat the cap screw threads with red Loctite #271 and tighten securely.

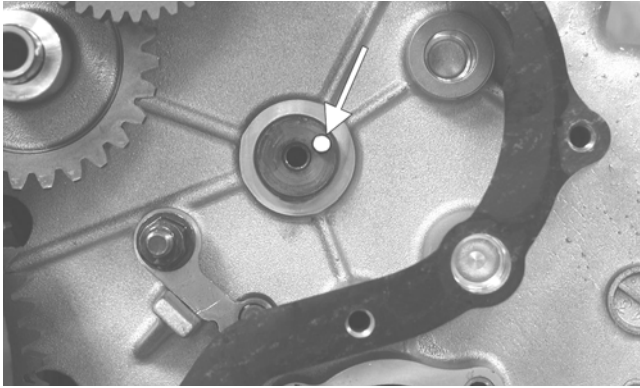

CD935A



CD934

6. Install the shift cam stopper, spring, and two washers; then coat the threads on the mounting stud with red Loctite #271 and install the nut. Tighten securely.

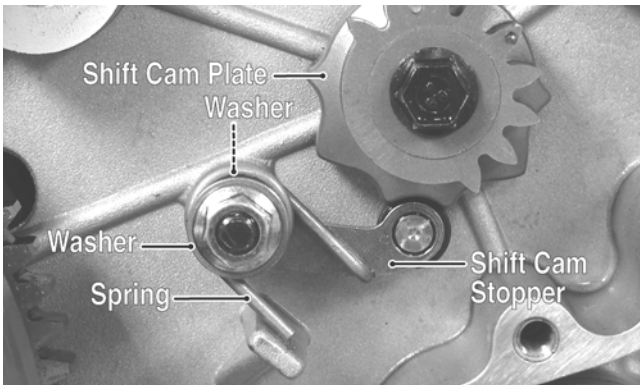

PR434A

7. Install the shift shaft with two washers making sure to align the timing mark on the shift shaft with the mark on the shift cam plate.

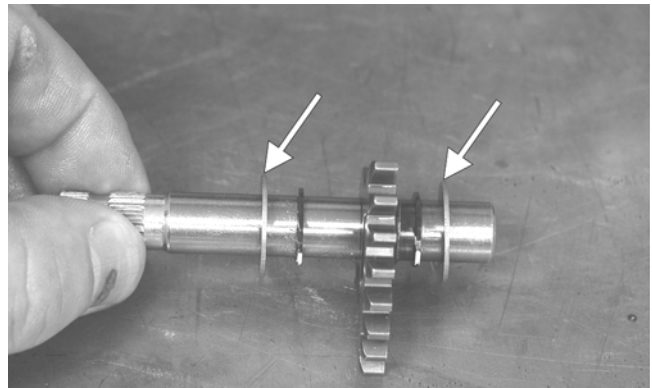

CD954A

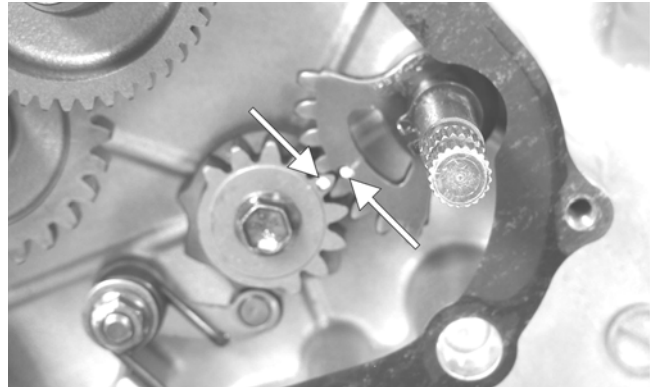

CD927A

8. Lubricate the magneto cover gasket with fresh engine oil; then place it into position on the two alignment pins. Make sure the outer shift shaft washer is in place.



PR431A

9. Install the magneto cover and secure with the cap screws. Tighten only until snug.
10. Place the spacer into position on the crankshaft making sure a new, lubricated O-ring is inside the spacer. Tighten the flange nut to 28 ft-lb.

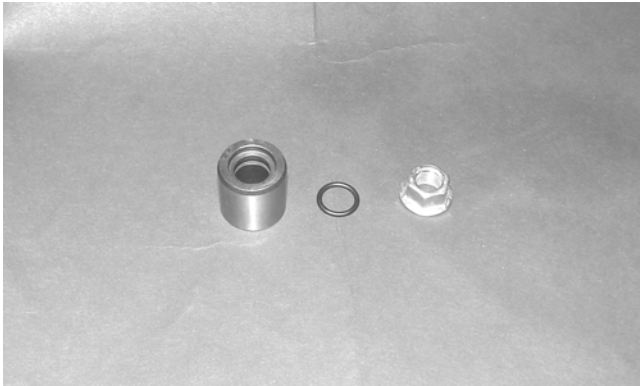

PR465

11. Tighten the cap screws (from step 9) to 8 ft-lb.
12. Clean the countershaft and trigger splines thoroughly and install the inner snap ring onto the shaft; then apply green Loctite #620 to the trigger and countershaft splines and install the trigger. Secure with a flat washer and outer snap ring.

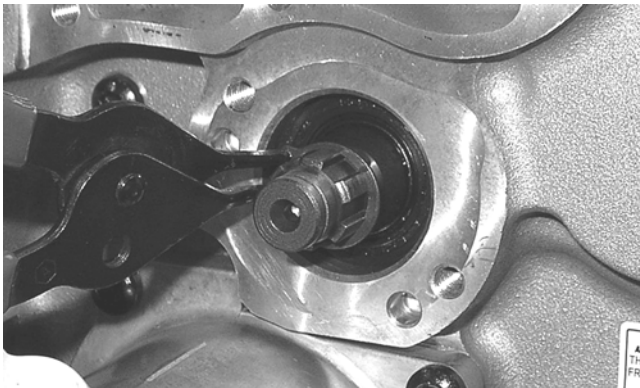

GZ253

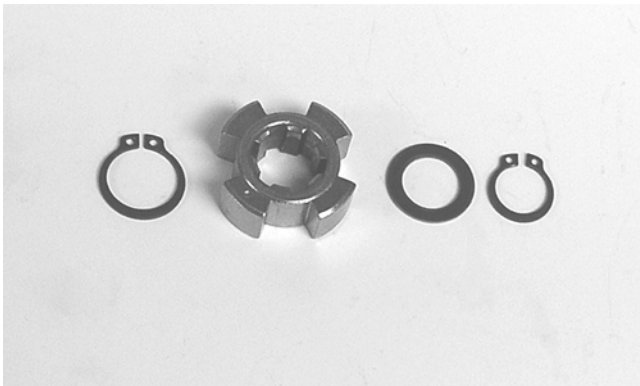

GZ254

13. Using a new gasket, install the speed sensor housing onto the crankcase and secure with two cap screws. Tighten to 8 ft-lb.

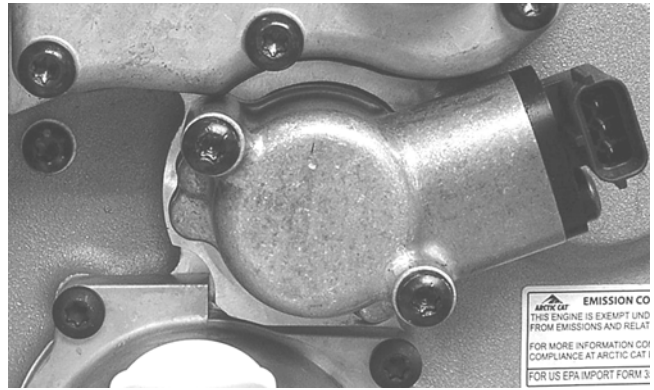

GZ232

14. Place the water pump into position and secure with two cap screws. Tighten securely.
15. Install the crossover tube on the water pump and cylinder head making sure the O-ring is properly positioned.
16. Install the shift arm on the shift arm shaft making sure the scribed marks (from removing) are aligned. Tighten securely.
17. Place the gasket and outer magneto cover into position on the side cover; then tighten four screws to 8 ft-lb.

Right-Side Components

■NOTE: For efficiency, it is preferable to remove and disassemble only those components which need to be addressed and to service only those components. The technician should use discretion and sound judgment.

<p>👉 AT THIS POINT</p>

<p>To service any one specific component, only limited disassembly of components may be necessary. Note the AT THIS POINT information in each sub-section.</p>
--

■NOTE: The engine/transmission does not have to be removed from the frame for this procedure.

Removing Right-Side Components

- A. V-Belt Cover**
- B. Driven Pulley**
- C. Clutch Cover**

1. Remove the cap screws securing the V-belt cover noting the location of the different-lengthed cap screws for installing purposes; then using a rubber mallet, gently tap on the cover tabs to loosen the cover.

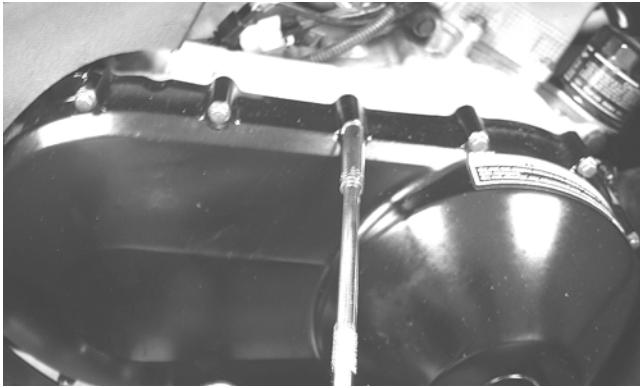

CD079

- Remove the nut securing the movable drive face; then remove the face. Account for a flat washer and spacer.

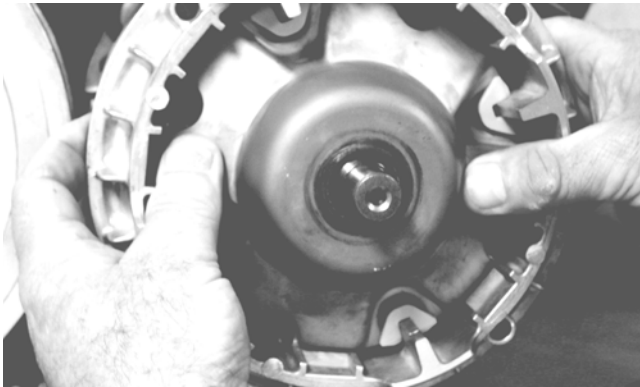

CD963

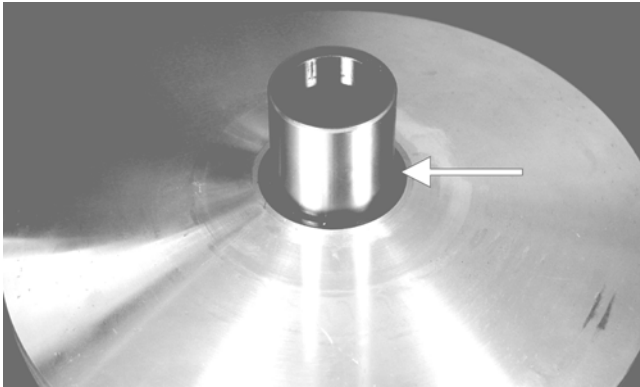

CD966A

- Remove the nut securing the fixed driven assembly; then remove the assembly.



PR388

- Remove the fixed drive face and V-belt.

- Using an impact driver, remove the cap screws securing the air intake plate; then remove the plate cushion.

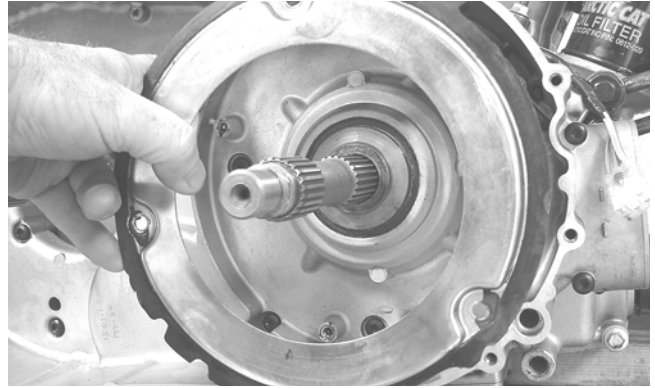

PR393

- Remove the cap screws securing the clutch cover. Note the location of the different-lengthed cap screws for installing purposes. Using a rubber mallet, carefully remove the cover. Account for two alignment pins.



CD973A

CAUTION

Care must be taken when removing the cover so the cover gasket is not damaged.

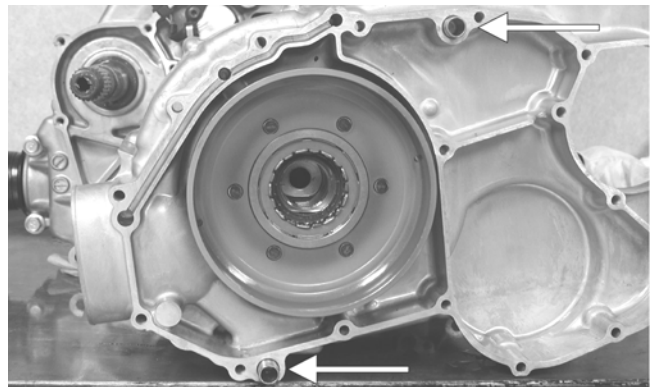

CD974A

■NOTE: For steps 7-13, refer to illustration PR398B.

■NOTE: To aid in installing, it is recommended the assemblies are kept together and IN ORDER.

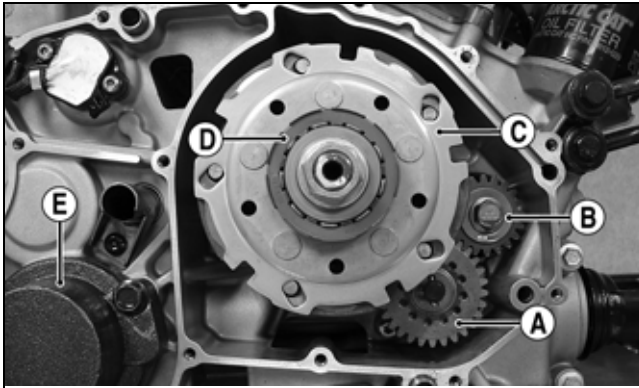

KEY

- | | |
|-------------------------|---|
| A. Oil Pump Driven Gear | D. One-Way Clutch
(Green Dot MUST Show) |
| B. Oil Pump Drive Gear | E. Final Drive Carrier Bearing
Housing |
| C. Clutch Shoe Assembly | |

PR398B

7. Remove the one-way clutch (D) from the clutch housing. Note the location of the green dot (or the word **OUTSIDE**) for installing purposes.
8. Using a hydraulic press, remove the clutch housing assembly from the clutch cover. Account for the left fixed drive spacer and an O-ring inside the fixed drive spacer.



CF085



CC596

■**NOTE:** Account for and inspect the clutch housing seal.

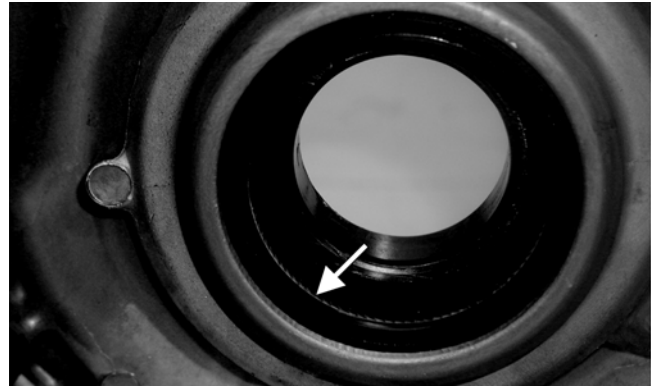

CF088A

9. Remove the two Allen-head screws securing the gear position switch; then remove the sensor. Account for two neutral contact pins and two springs.

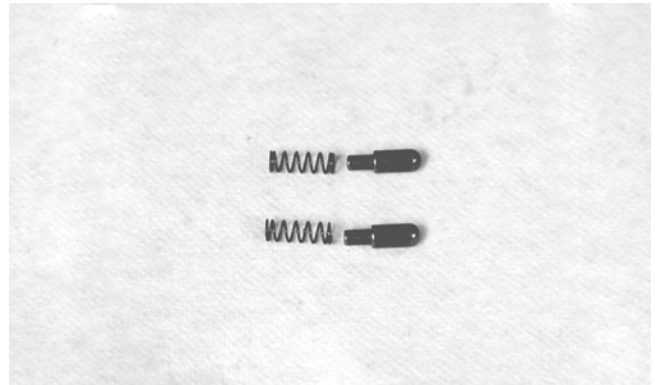

CD997

10. Remove the nut (left-hand threads) securing the clutch shoe assembly (C).



FI279A

11. Remove the cap screw securing the oil pump drive gear (B). Account for a cap screw, washer, pin, and spacer.

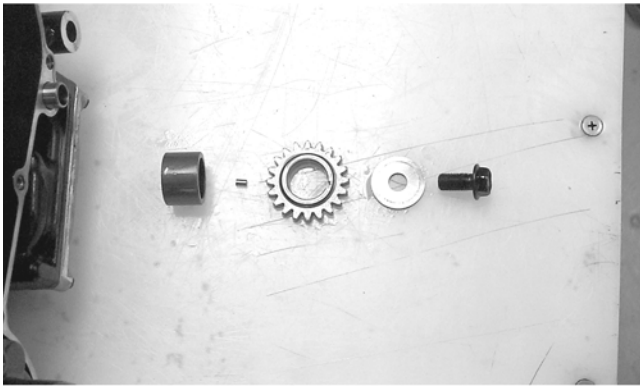

CC606

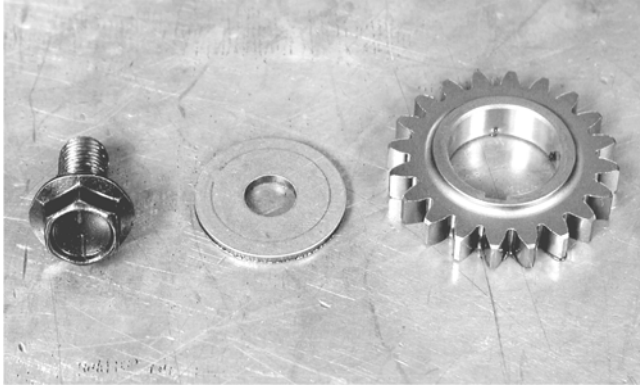

CD987



CD993

12. Using an impact driver, remove the Allen-head screws securing the final drive carrier bearing housing (E); then remove the housing and account for two alignment pins.



CD999

13. Remove the snap ring securing the oil pump driven gear (A); then remove the gear noting the direction of the sides of the gear for installing purposes. Account for a pin and a washer.

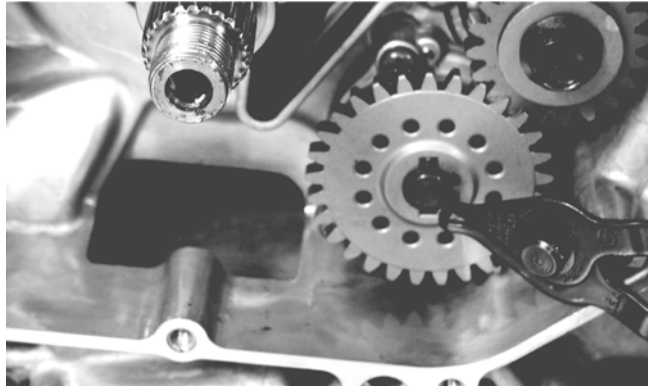

CD984

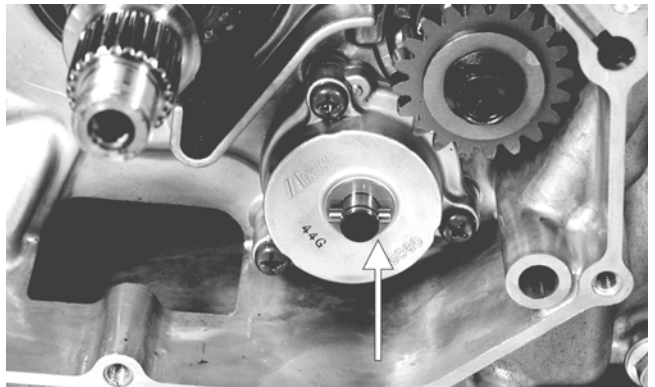

CD895A

14. Remove the cap screws securing the oil pump; then remove the pump.



CD988

3

Servicing Right-Side Components

■NOTE: Whenever a part is worn excessively, cracked, damaged in any way, or out of tolerance, replacement is necessary.

INSPECTING CENTRIFUGAL CLUTCH SHOE

1. Inspect the clutch shoes for uneven wear, chips, cracks, or discoloration. If any shoe is damaged, replace the complete set.
2. Inspect the clutch shoes for wear or damage. If any shoe is worn to the bottom of the groove, replace the complete set.

CAUTION

Always replace the clutch shoes as a complete set or severe imbalance could occur.

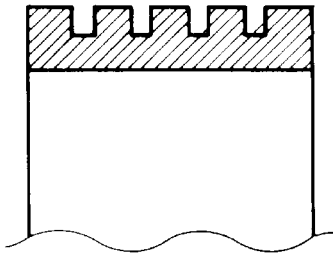

Inspecting clutch shoe groove

ATV1014

INSPECTING CLUTCH HOUSING

1. Inspect the clutch housing for burns, grooving, cracks, or uneven wear.
2. If the housing is damaged in any way, the housing must be replaced.

INSPECTING PRIMARY ONE-WAY DRIVE

1. Insert the drive into the clutch housing.
2. Rotate the inner race by hand and verify the inner race rotates only one direction.
3. If the inner race is locked in place or rotates both directions, the drive assembly must be replaced.

INSPECTING OIL PUMP

1. Inspect the pump for damage.
2. It is inadvisable to remove the screw securing the pump halves. If the oil pump is damaged, it must be replaced.

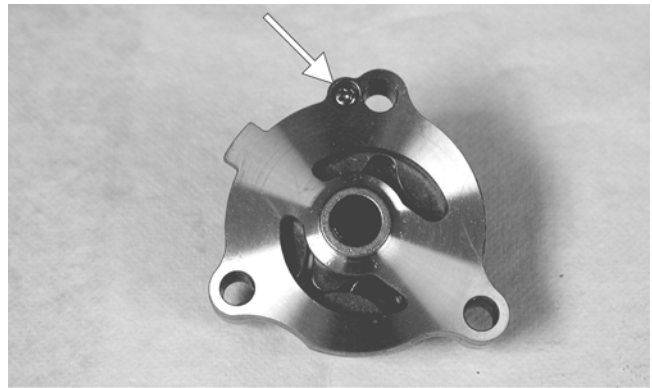

CD988A

DRIVEN PULLEY

■NOTE: The driven pulley is a non-serviceable component. If pulley faces, cam ramps, or sheave bushings are worn, the assembly must be replaced. Do not to disassemble the driven pulley.

Installing Right-Side Components

1. Install the gear position switch making sure the two neutral contact pins and the two springs are properly positioned. Tighten the cap screws securely.

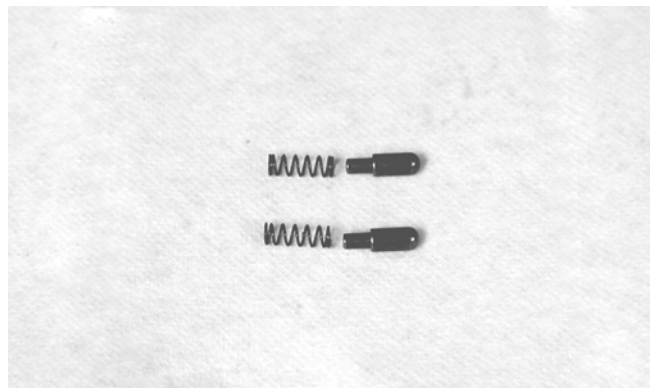

CD997



CD994

2. Install the secondary shaft bearing housing making sure the two alignment pins are properly positioned. Tighten the cap screws to 28 ft-lb.

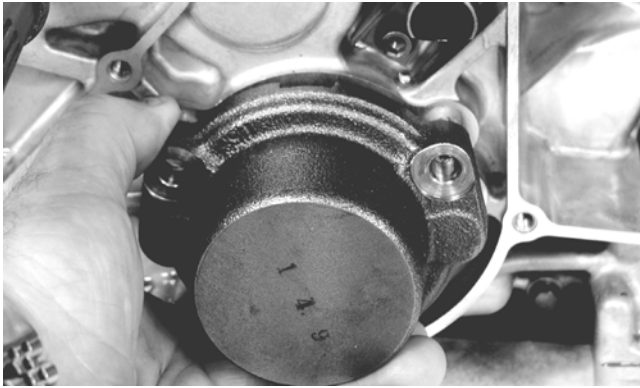

CD999

3. Install the oil pump onto the engine; then tighten the cap screws securely.



CD988

4. Install the oil pump drive gear spacer onto the crank balancer shaft. Grease the pin and insert it into the shaft; then install the drive gear making sure the raised side of the gear is facing toward the inside. Secure the gear with the cap screw (threads coated with red Loctite #271) and the washer. Tighten the cap screw to 62 ft-lb.

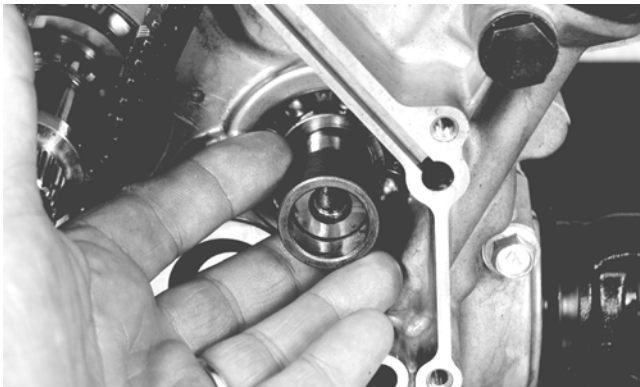

CD992

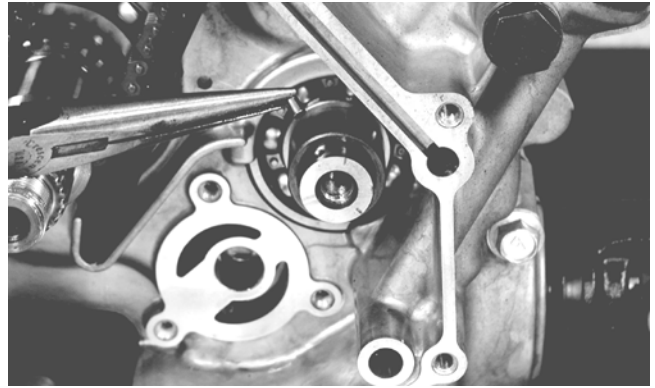

CD991

5. Grease the driven gear pin and insert it into the oil pump shaft; then install the driven gear (noting the direction of the sides of the gear from removing). Secure with a snap ring.

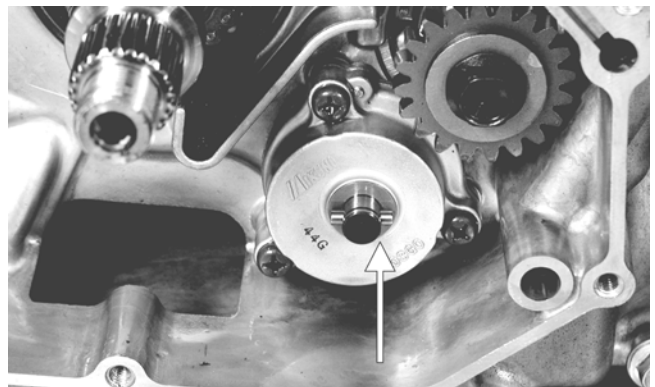

CD985A

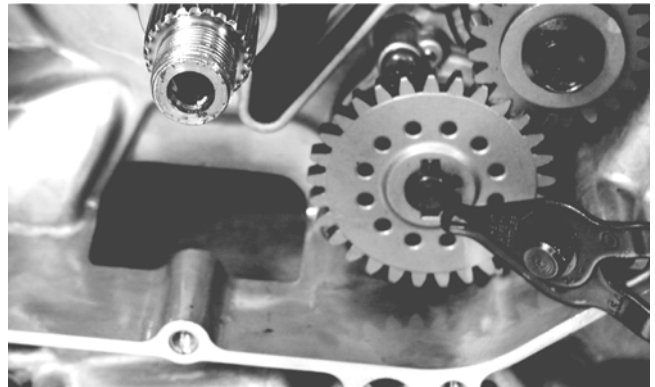

CD984

■ **NOTE:** When installed correctly, the sides of the drive and driven gears will be flush with each other.

6. Install the clutch shoe assembly and secure with the flange nut (threads coated with red Loctite #271). Tighten to 221 ft-lb.

3



PR410A

7. Install the clutch cover alignment pins into the crankcase, apply oil to the cover gasket, and install the gasket onto the crankcase.
8. Install the one-way clutch onto the clutch shoe assembly.

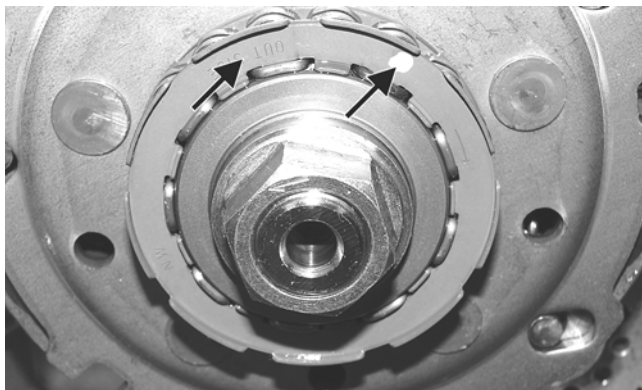

PR399A

CAUTION

When installed correctly, the green dot (or the word OUTSIDE) on the one-way clutch is visible.

9. Lightly grease the clutch housing seal; then insert the left fixed drive spacer.

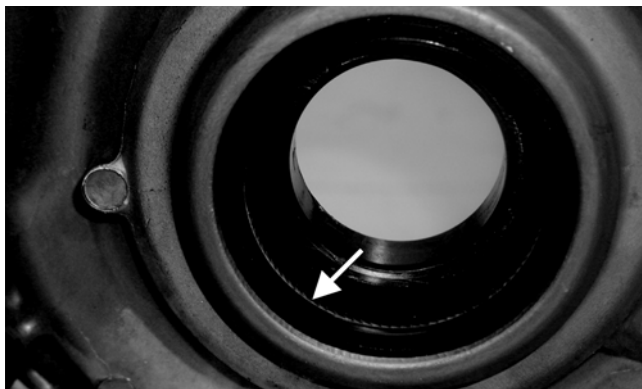

CF088A

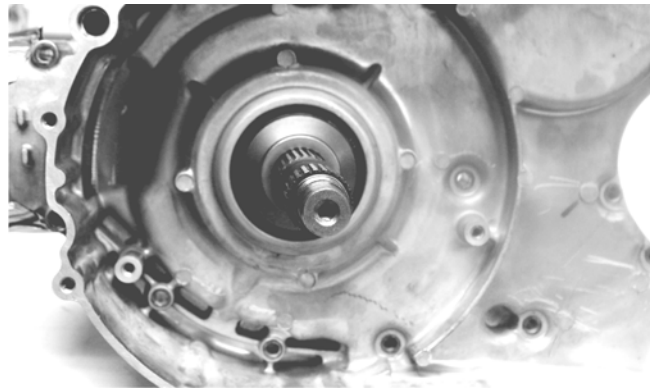

CF086

10. Apply grease to the outer edges of the clutch housing; then from inside the clutch cover, install the clutch housing into the cover using a rubber mallet.
11. Place the clutch cover/clutch housing assembly into position on the crankcase; then secure with the cap screws making sure the different-lengthed cap screws are in their proper location. Tighten to 8 ft-lb.

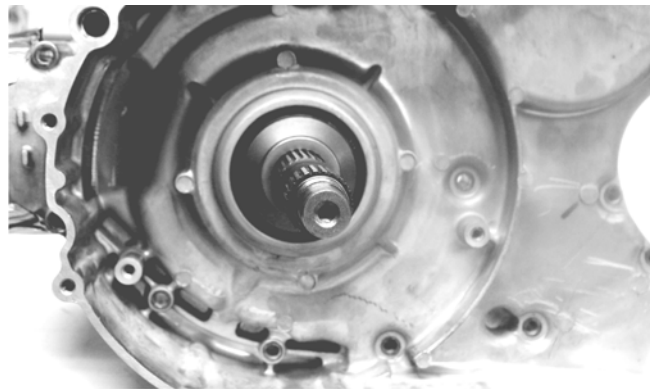

CF086

12. Place the air intake plate cushion into position; then install the air intake plate. Tighten the cap screws (threads treated with a small amount of red Loctite #271) securely.

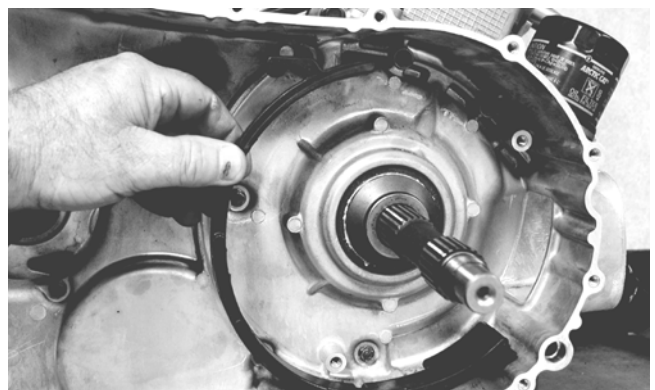

CD971

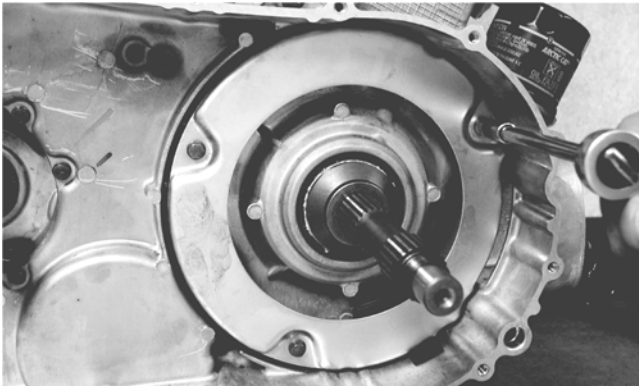

CD970

13. Place the driven pulley assembly into position and secure with the nut. Using Spanner Wrench, tighten to 80 ft-lb.
14. Slide the fixed drive face onto the shaft.
15. Spread the faces of the driven pulley by threading a 6 mm cap screw into the threaded boss; then turn clockwise until pulley faces are opened approximately 1/2 in.
16. Place the V-belt into position on the driven pulley and over the front shaft.

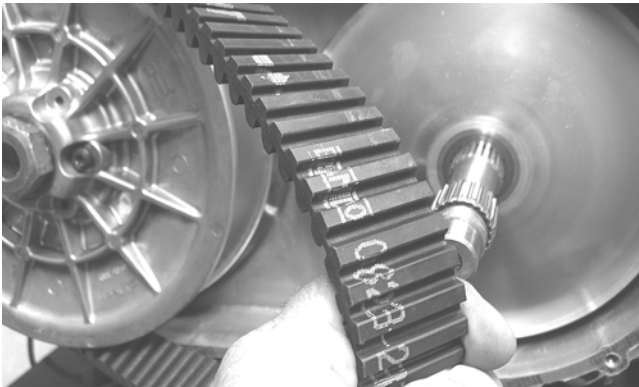

GZ085

■NOTE: The arrows on the V-belt should point in the direction of rotation.

17. Pinch the V-belt together near its center and slide the spacer and movable drive face onto the driveshaft. Secure the drive face with a washer and nut (coated with red Loctite #271). Using Spanner Wrench, tighten the nut to 165 ft-lb.

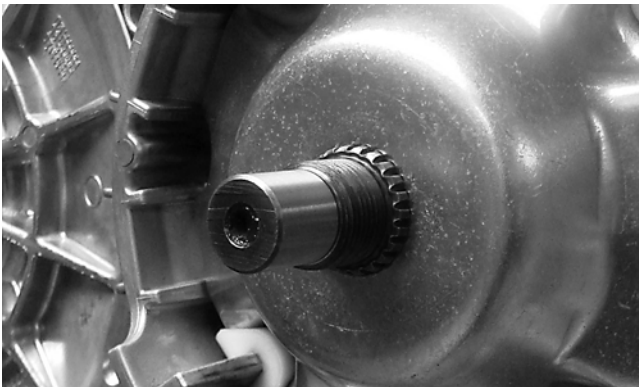

GZ485

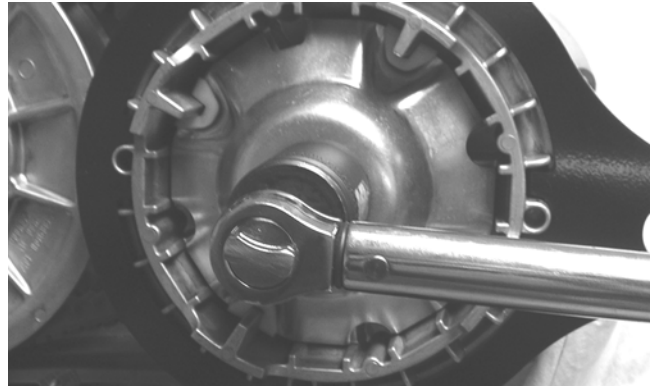

CF261

CAUTION

Make sure the splines extend beyond the drive face or a false torque reading and spline damage may occur.

■NOTE: At this point, the cap screw can be removed from the driven pulley face.

18. Rotate the V-belt and driven pulley/clutch until the V-belt is flush with the top of the driven pulley.
19. Place the V-belt cover gasket into position; then install the cover and secure with the cap screws making sure the different-lengthed cap screws are in their proper location. Tighten the cap screws to 8 ft-lb.

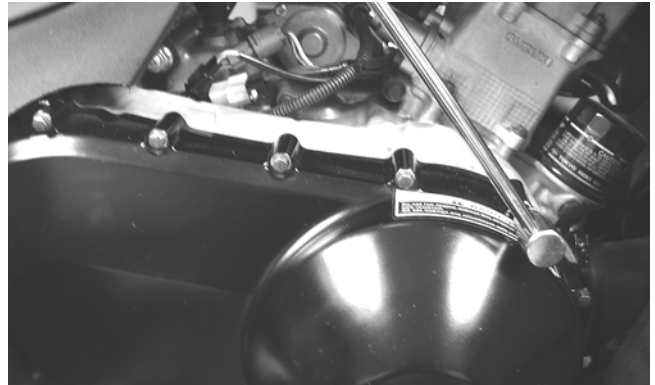

CD083

Center Crankcase Components

■NOTE: This procedure cannot be done with the engine/transmission in the frame. Complete Removing procedures for Top-Side, Right-Side, and Left-Side must precede this procedure.

■NOTE: For efficiency, it is preferable to remove and disassemble only those components which need to be addressed and to service only those components. The technician should use discretion and sound judgment.

Separating Crankcase Halves

1. Remove the left-side cap screws securing the crankcase halves. Note the location of the different-lengthed cap screws.
2. Remove the right-side cap screws securing the crankcase halves. Note the location of the different-lengthed cap screws.
3. Using the Crankcase Separator/Crankshaft Remover and tapping lightly with a rubber mallet, separate the crankcase halves. Account for four alignment pins.

■NOTE: To keep the shaft/gear assemblies intact for identification, tap the shafts toward the left-side crankcase half when separating the halves.

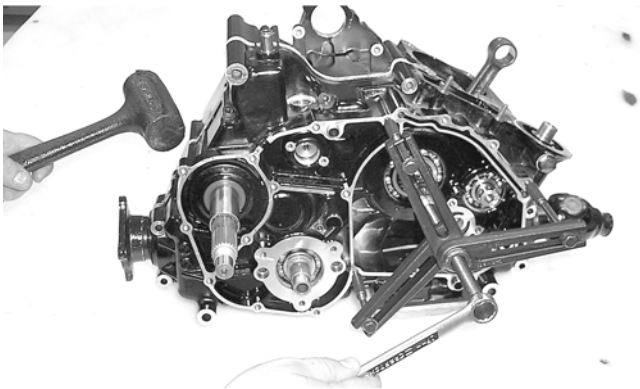

CC665

Disassembling Crankcase Half

■NOTE: For steps 1-7, refer to illustration CC821B.

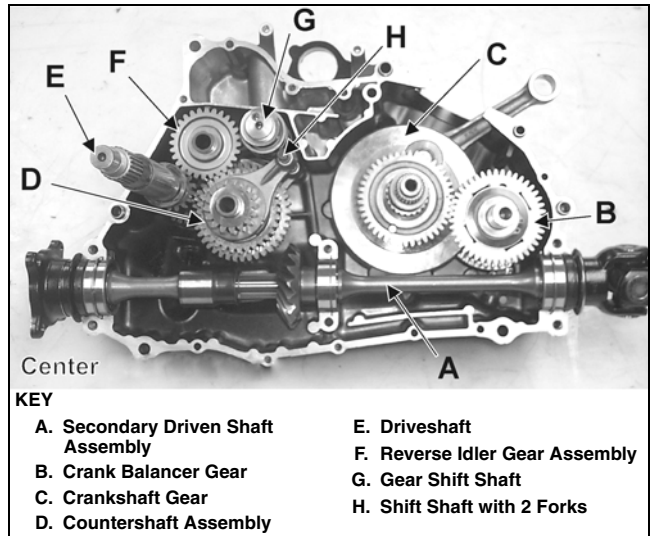

CC821B

■NOTE: To aid in installing, it is recommended the assemblies are kept together and IN ORDER.

1. Remove the secondary driven shaft assembly (A) noting the location of the bearing locating pins. Account for the bearing C-ring.

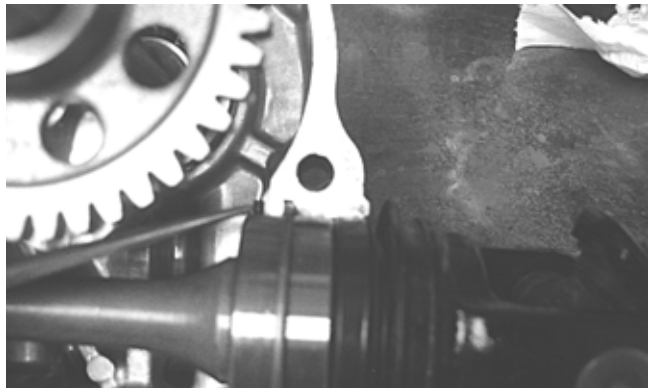

CD267

2. Remove the reverse idler gear assembly (F). Account for all washers, shaft, bushing, and the gear.

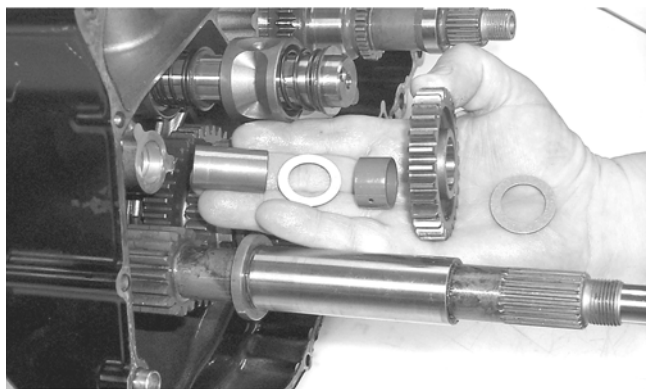

CC668

3. Remove the shift shaft (H); then remove the two forks taking note of the direction of the tabs on the forks for assembling purposes.
4. Remove the gear shift shaft (G) noting the location of the two holes on the end of the shaft. Account for two washers.



PR380A

- Remove the countershaft assembly (D). Account for a washer on each end of the countershaft.

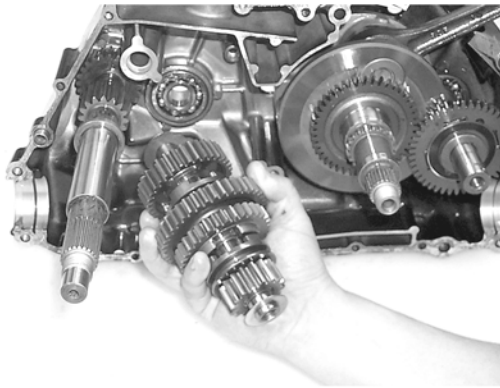

CC674

■NOTE: Do not disassemble the countershaft assembly unless necessary. If necessary, see Servicing Center Crankcase Components sub-section.

- Using a rubber mallet, tap on the crankcase to remove the driveshaft (E).

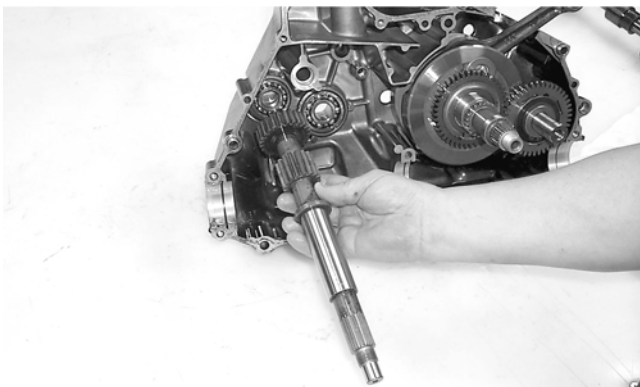

CC675

- Note the timing marks on the crank balancer gear (B) and crankshaft gear (C) for assembling purposes; then slide the crank balancer gear off the crank balancer. Account for the key in the keyway.



CD826

- Remove the crank balancer.

■NOTE: There is a flat spot on the crank balancer bearing flange to allow clearance past the crankshaft.



CD832B

- Remove the snap ring securing the water pump driven gear shaft.

- Using a hydraulic press, remove the crankshaft assembly.

■NOTE: Use a protective end cap to prevent damage to the crankshaft threads.

- Remove the cap screws securing the oil strainer cap; then remove the cap.

- Remove the two cap screws securing the oil strainer; then remove the strainer.

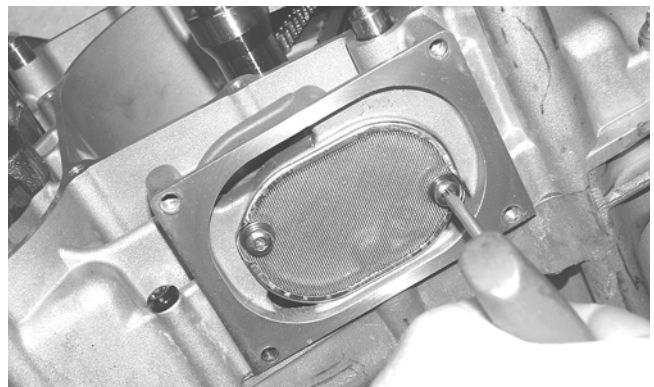

PR406

CAUTION

Unless the secondary drive gear, bevel gear, or bearings require service, do not remove the secondary drive assembly from the case. If removed, bevel gear backlash will have to be adjusted requiring re-shimming of the drive bevel gear shaft.

13. To remove the secondary drive/bevel gear, remove the secondary drive bearing housing; then remove the nut securing the drive/bevel gear shaft in the bearing and using a plastic mallet, drive the shaft out of the bearing. Account for shim/shims.

■NOTE: Shims should be measured and kept for a starting point in adjusting backlash

Servicing Center Crankcase Components

■NOTE: Whenever a part is worn excessively, cracked, damaged in any way, or out of tolerance, replacement is necessary.

SECONDARY OUTPUT DRIVE GEARS

Initial Set-Up

■NOTE: If the secondary output driven shaft is replaced or disassembled, the initial set-up must be performed to establish correct gear tooth contact. If only the secondary output drive shaft or secondary output driven gear are replaced, proceed to Correcting Backlash in this sub-section.

1. Install a new bearing (A) onto the secondary driven shaft (B) making sure the bearing locating groove is directed away from the driven gear splines.

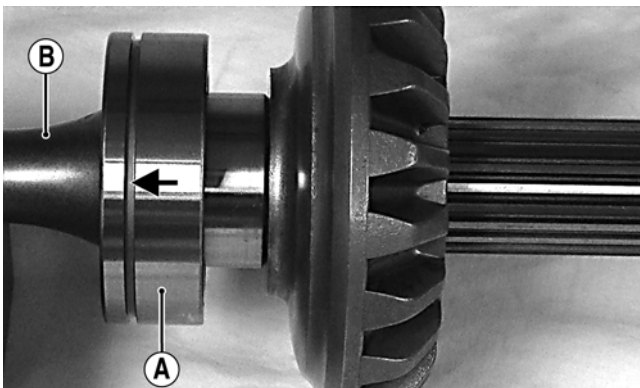

MT011A

2. Using a suitable press, install the driven gear (C) on the shaft until the gear firmly seats on the shoulder of the shaft.

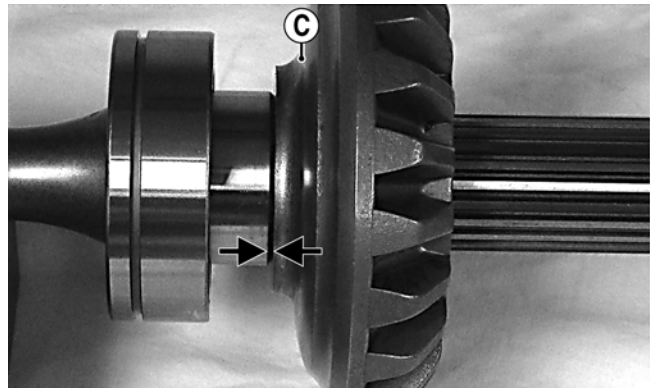

MT011B

3. If installing the existing shaft, start with the shims removed during disassembly or if installing a new shaft, start with approximately 1.0 mm shims at point (D); then install the output drive shaft bearing (E) making sure the locating pin is directed toward the center of the shaft.



MT012

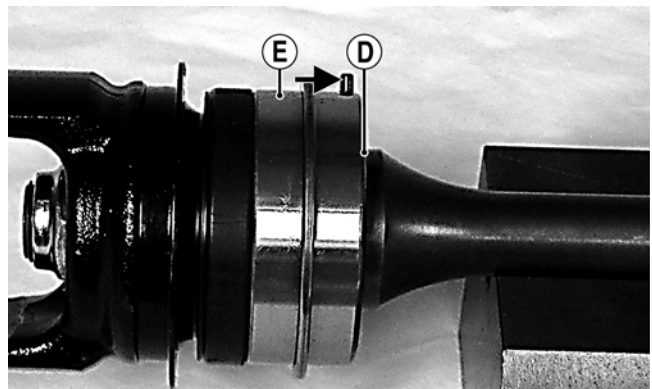

MT008A

4. Install a new seal (F), output yoke (G), and nut (H) and tighten to 74 ft-lb.

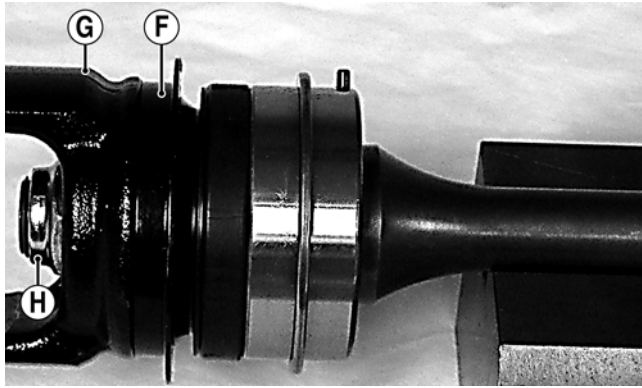

MT008B

■NOTE: Do not use a new lock nut at this time as this procedure may have to be repeated.

- Place the assembled shaft into the left crankshaft case; then lightly coat the gear teeth with machinist's lay-out dye. Rotate the shafts through several rotations in both directions. Gear contact should extend from the root to the top of the gear teeth.

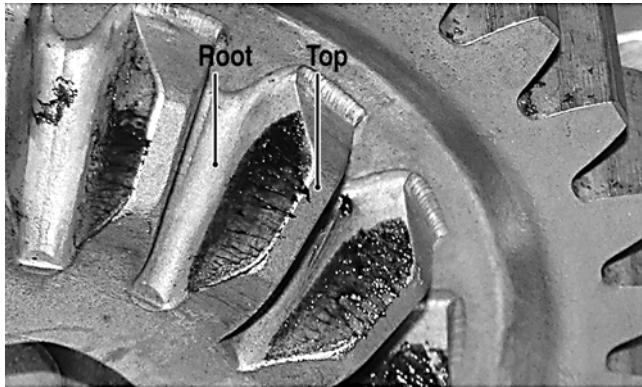

MT016A

- To adjust tooth contact, use the following chart to correctly shim the driven shaft.

Tooth Contact	Shim Correction
Contact at Top	Increase Shim Thickness
Contact at Root	Decrease Shim Thickness

- After correct tooth contact is established, proceed to Checking Backlash in this sub-section.

Checking Backlash

- If removed, install the secondary drive/bevel gear shaft into the crankcase; then tighten the nut to 59 ft-lb.
- Install the secondary drive bearing support; then install the secondary driven output shaft into the crankcase.
- Mount the dial indicator so the tip is contacting a tooth on the secondary drive bevel gear.
- While rocking the drive bevel gear back and forth, note the maximum backlash reading on the gauge.

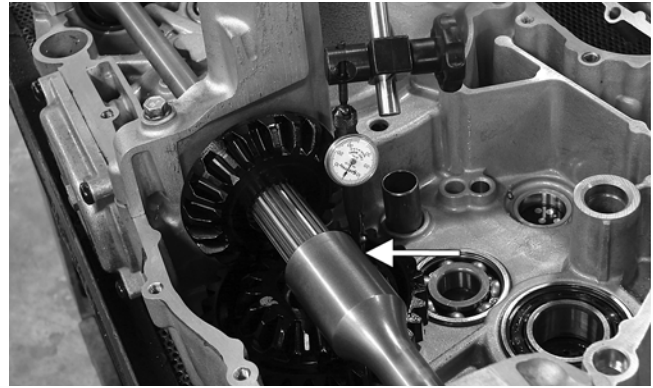

MT005A

- Acceptable backlash range is 0.115-0.390 mm (0.005-0.015 in.).

Correcting Backlash

■NOTE: If backlash measurement is within the acceptable range, no correction is necessary.

- If backlash measurement is less than specified, remove an existing shim, measure it, and install a new thinner shim.
- If backlash measurement is more than specified, remove an existing shim, measure it, and install a thicker shim.

■NOTE: Continue to remove, measure, and install until backlash measurement is within tolerance. Note the following chart.

Backlash Measurement	Shim Correction
Under 0.115 mm (0.005 in.)	Decrease Shim Thickness
At 0.115-0.390 mm (0.005-0.015 in.)	No Correction Required
Over 0.390 mm (0.015 in.)	Increase Shim Thickness

After backlash and tooth contact are within specifications, apply red Loctite #271 to the driveshaft threads and driven output shaft threads; then using new nuts, tighten the output shaft nut to 59 ft-lb and the output yoke nut to 74 ft-lb.

CRANKSHAFT ASSEMBLY

■NOTE: The crankshaft and connecting rod is a non-serviceable assembly. If any component is out of specification, the assembly must be replaced.

Measuring Connecting Rod (Small End Inside Diameter)

- Insert a snap gauge into the upper connecting rod small end bore; then remove the gauge and measure it with micrometer.

3

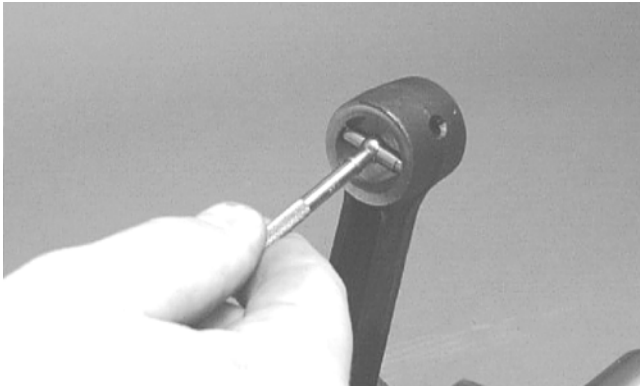

CC290D

2. Maximum diameter must not exceed specifications.

Measuring Connecting Rod (Small End Deflection)

1. Place the crankshaft on a set of V-blocks and mount a dial indicator and base on the surface plate. Position the indicator contact point against the center of the connecting rod small end journal.
2. Zero the indicator and push the small end of the connecting rod away from the dial indicator.
3. Maximum deflection must not exceed specifications.

Measuring Connecting Rod (Big End Side-to-Side)

1. Push the lower end of the connecting rod to one side of the crankshaft journal.
2. Using a feeler gauge, measure the gap between the connecting rod and crankshaft journal.

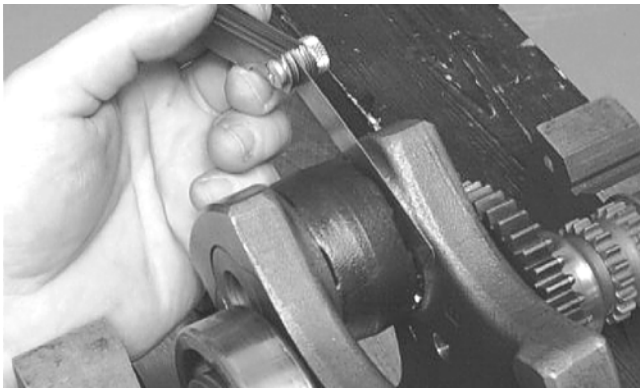

CC289D

3. Acceptable gap range must be within specifications.

Measuring Crankshaft (Runout)

1. Place the crankshaft on a set of V blocks.
2. Mount a dial indicator and base on the surface plate. Position the indicator contact at point 1 of the crankshaft.

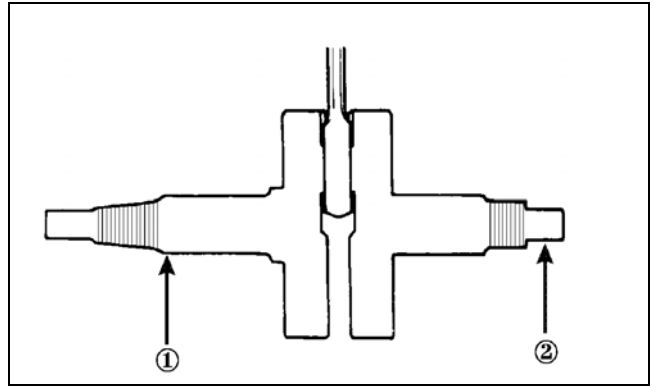

ATV-1074

3. Zero the indicator and rotate the crankshaft slowly.

CAUTION

Care should be taken to support the connecting rod when rotating the crankshaft.

4. Maximum runout must not exceed specifications.

■NOTE: Proceed to check runout on the other end of the crankshaft by positioning the indicator contact at point 2 and following steps 3-4.

Measuring Crankshaft (Web-to-Web)

1. Using a calipers, measure the distance from the outside edge of one web to the outside edge of the other web.

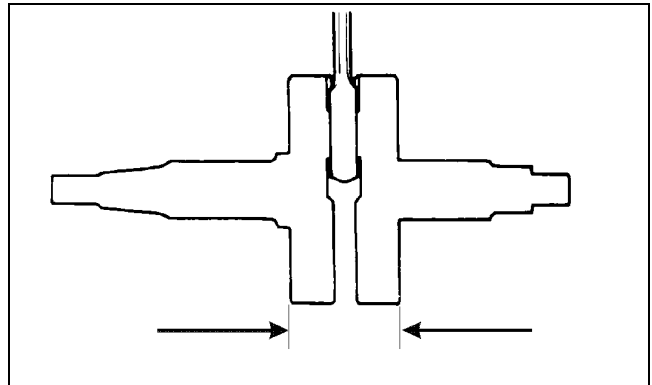

ATV-1017

2. Acceptable width range must be within specifications.

COUNTERSHAFT

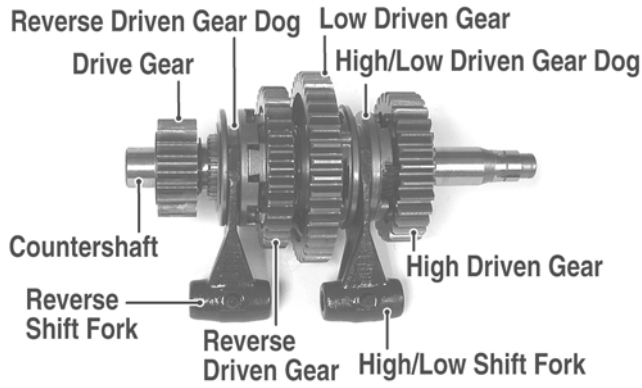

GZ281A

CAUTION

When disassembling the countershaft, care must be taken to note the direction each major component (dog, gear) faces. If a major component is installed facing the wrong direction, transmission damage may occur and/or the transmission will malfunction. In either case, complete disassembly and assembly will be required.

Disassembling

1. Remove the shift forks noting the positions for assembling; then remove the high driven gear outer washer, high driven gear, high driven gear bearing, high driven gear bushing, and high driven gear inner washer.

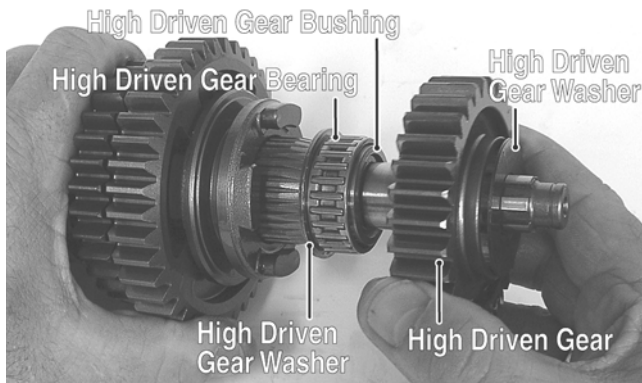

GZ283A

2. Remove the drive gear; then remove the snap ring securing the reverse driven gear dog and bushing to the countershaft.



GZ296

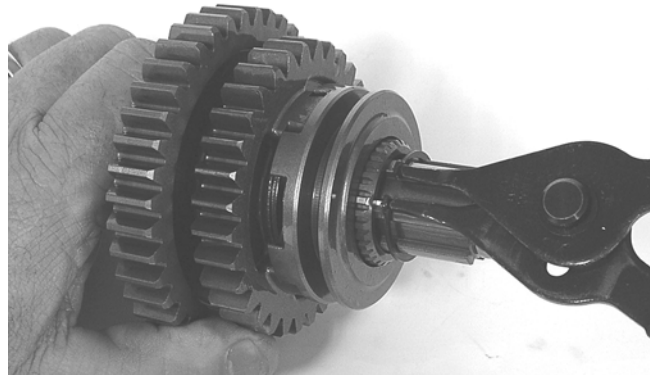

GZ312

3. Remove the reverse driven gear dog.



GZ313A

4. Remove the snap ring securing the reverse driven gear and washer; then remove the washer and gear.



GZ314

5. Remove the reverse driven washer; then remove the low driven gear locking washer.

3



GZ320

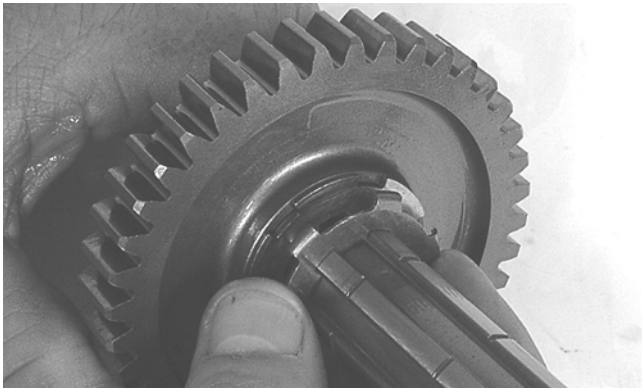

GZ319

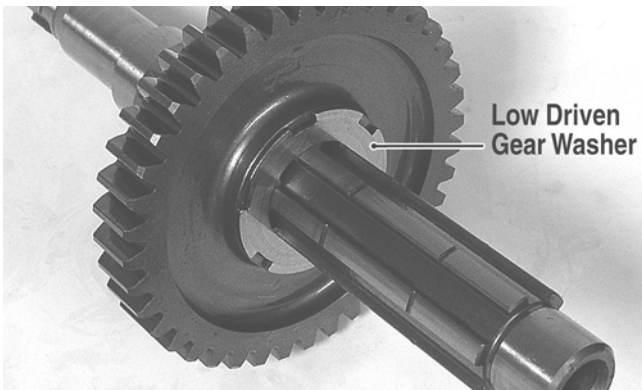

GZ318A

6. Remove the low driven gear. Account for a bearing, bushing, and thrust washer.

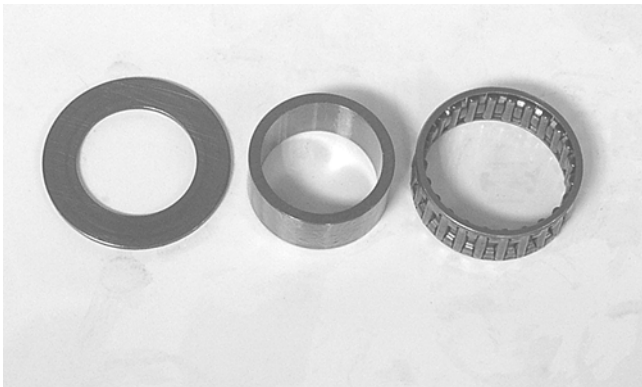

GZ316

Assembling

1. From the drive gear end, install a thrust washer, bushing, and bearing; then install the low driven gear and washer.

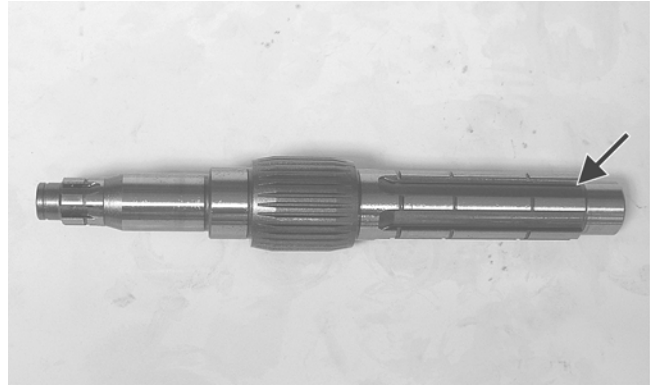

GZ317A

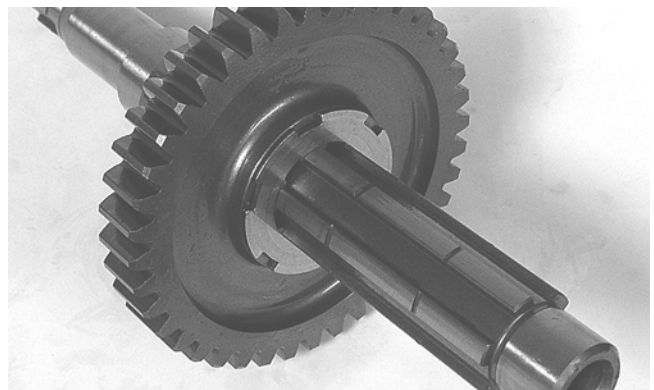

GZ318

2. Install the low driven gear locking washer; then install the inner reverse driven gear washer.

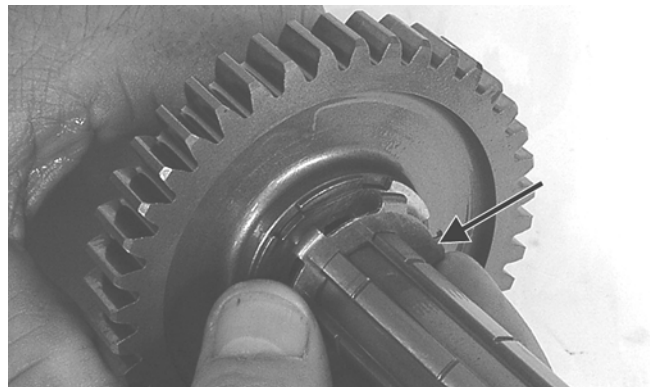

GZ319B

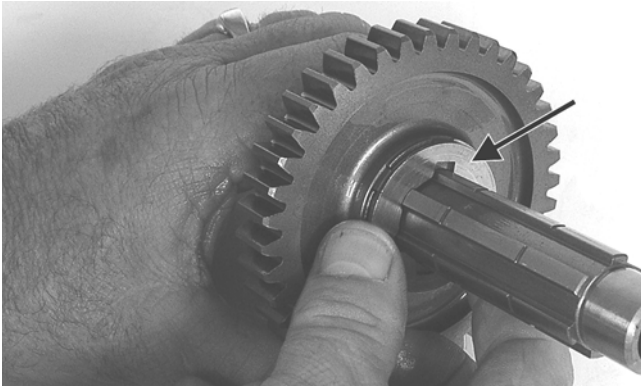

GZ320B

3. Install the reverse driven bushing and bearing; then install the reverse driven gear.

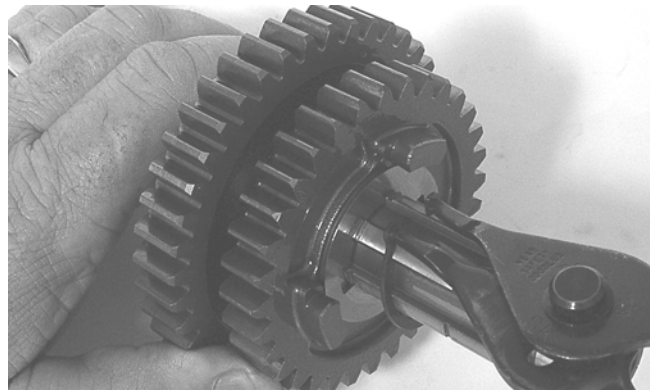

GZ314

5. Install the reverse driven gear dog onto the countershaft and secure with a snap ring.

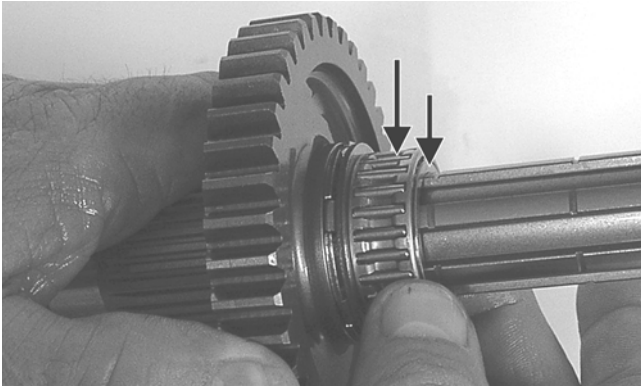

GZ286A



GZ313A

3



GZ287

4. Install the outer reverse driven washer; then secure the reverse driven gear assembly with a snap ring.

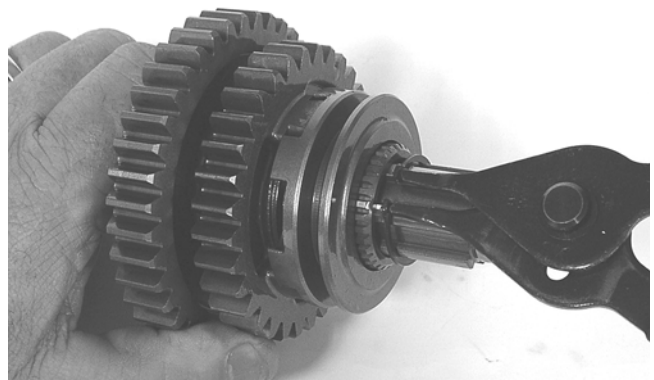

GZ312

6. From the opposite end of the countershaft, install the high/low driven gear dog (A), thrust washer (B), bushing (C), bearing (D), high/low driven gear (E), and spacer washer (F).

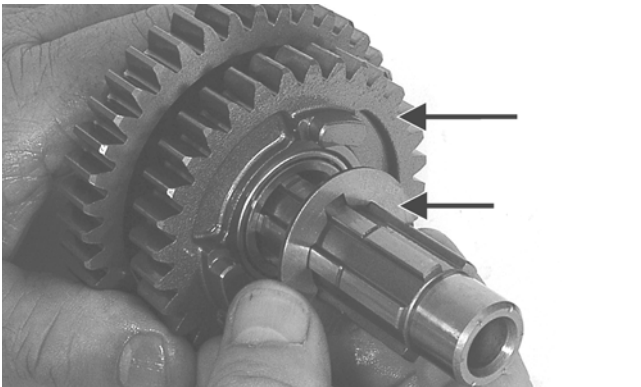

GZ288A

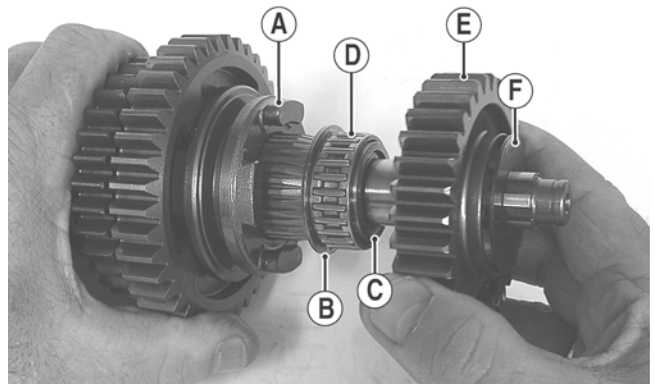

GZ283B

7. Install the drive gear washer and the shift forks. The countershaft is now ready for installation.

■NOTE: When installing the countershaft assembly, account for the washer on each end of the shaft.

Assembling Crankcase Half

1. Install the secondary driven gear assembly.

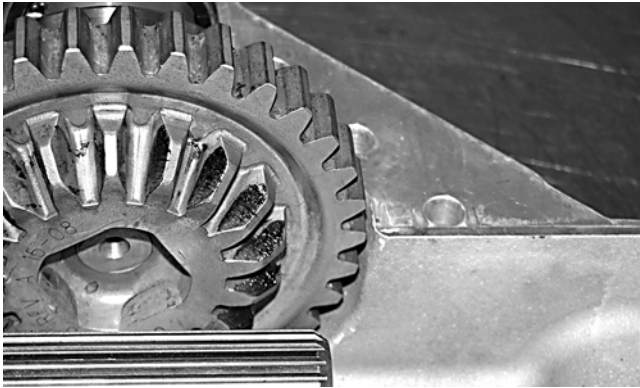

MT014

2. Apply a liberal amount of engine oil to the crankshaft bearing. Using a propane torch, heat the bearing until the oil begins to smoke; then slide the crankshaft assembly into place.

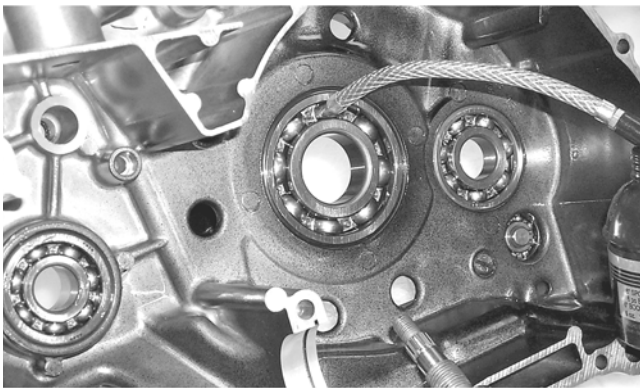

CC688

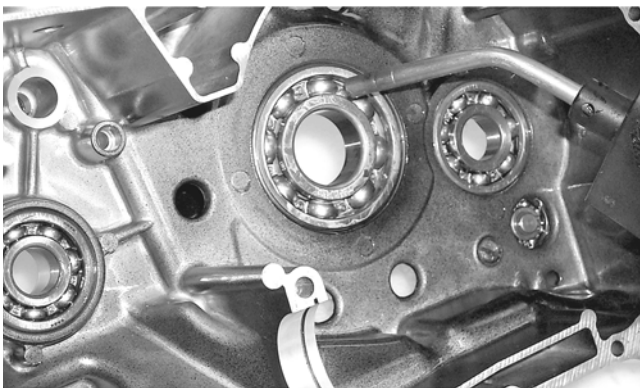

CC689

■NOTE: If heating the bearing is not possible, the crankshaft can be installed using a crankshaft installing tool.

3. Install the crank balancer.



CD832B

■NOTE: It will be necessary to rotate the crank balancer until the counterweight is facing away from the crankshaft; then rotate the crankshaft clockwise into the journal area to allow the crank balancer to be fully seated.

4. Place the key into the crank balancer keyway; then install the crank balancer gear making sure the alignment dots on the crank balancer gear and the crankshaft gear align.

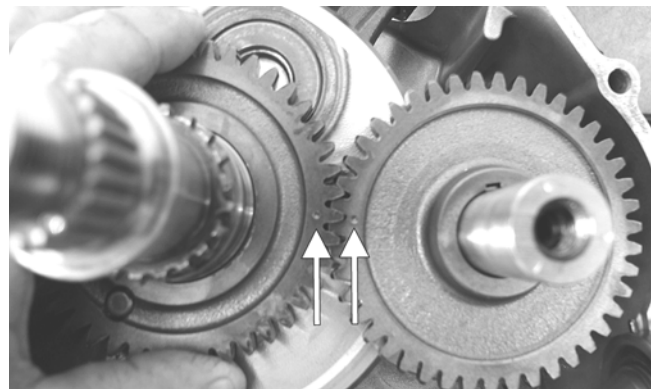

CD826A

5. Install the driveshaft.

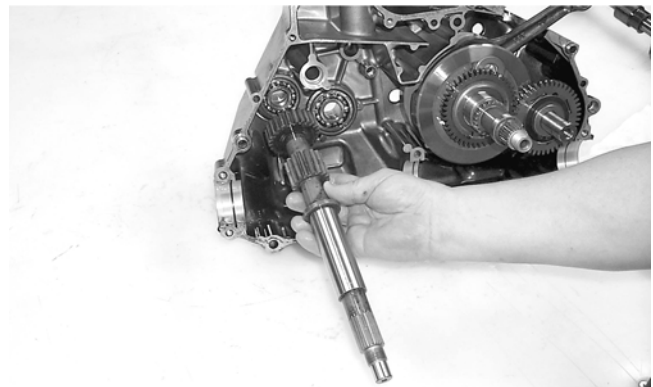

CC675

6. Place a washer on each end of the countershaft assembly; then install the assembly.

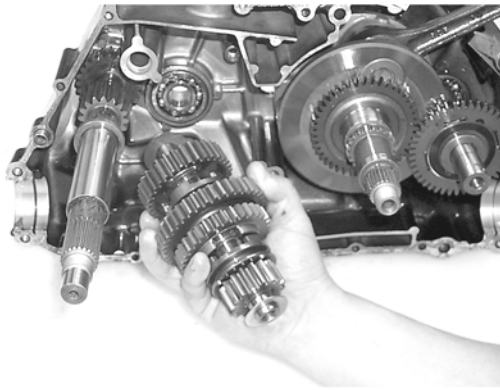

CC674

7. Place a washer on each end of the gear shift shaft; then install the shaft assembly making sure the two holes on the end of the shaft are positioned vertically.
8. Insert the two shift forks into the sliding dogs noting the direction of the tabs from disassembling; then install the shift fork shaft.

■**NOTE:** Make sure the shift fork tabs face upward and they are properly seated into the shift cams.

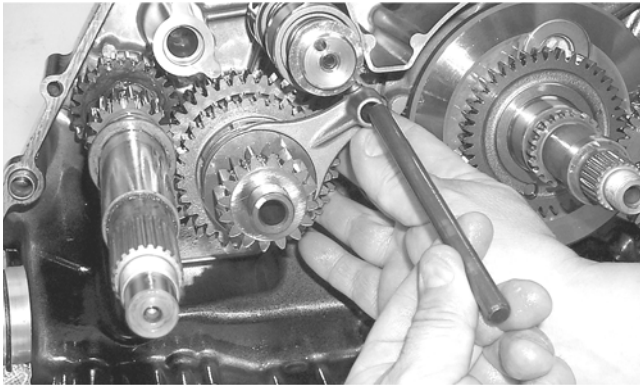

CC669

9. Install the reverse idler gear assembly noting the positioning of the two washers, gear, bushing, and shaft.

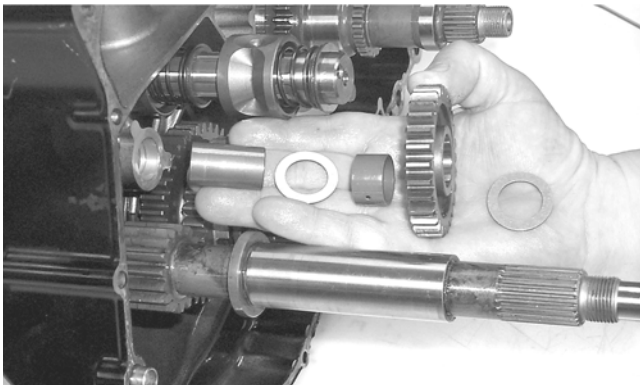

CC668

10. Install the front and rear secondary driven shaft assemblies into the left side of the crankcase making sure the bearing locating pins are facing upward and the bearing C-ring is fully seated in the crankcase.

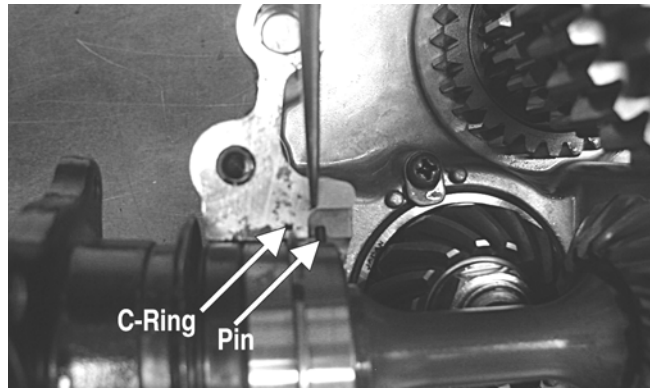

CD268A

11. Place the oil strainer into position; then secure with the two screws.
12. Place the oil strainer cap into position making sure the O-ring is in position; then secure the cap with cap screws. Tighten securely.

Joining Crankcase Halves 3

1. Apply High-Temp Sealant to the right-side mating surface smoothing out any build-up or bumps.
2. Lightly oil all bearings and grease all shafts in the left-side crankcase.
3. Using a plastic mallet, lightly tap the case halves together until cap screws can be installed.
4. From the right side, install the 8 mm cap screws; then tighten only until snug.

■**NOTE:** During the tightening procedure, rotate the shafts back and forth frequently to ensure no binding or sticking occurs.

5. From the left side, install the remaining 8 mm cap screws (two inside the case); then tighten only until snug.
6. From the left side, install the case half 6 mm cap screws; then tighten only until snug.
7. From the right side, install the 6 mm cap screws; then tighten only until snug.
8. In a crisscross/case-to-case pattern, tighten the 8 mm cap screws (from steps 4-5) until the halves are correctly joined; then tighten to 20 ft-lb.
9. In a crisscross/case-to-case pattern, tighten the 6 mm cap screws (from steps 6-7) to 10 ft-lb.

⚠ **AT THIS POINT**

After completing center crankcase components, proceed to Installing Right-Side Components, to Installing Left-Side Components, and to Installing Top-Side Components.

Installing Engine/Transmission

■NOTE: Arctic Cat recommends new gaskets and O-rings be installed whenever servicing the vehicle.

1. Using a suitable lifting sling and engine hoist, lower the engine into the vehicle engaging the slotted rear engine mount brackets with the engine mounts; then install the front through-bolt.
2. Tighten the flange nuts on the rear cradle to 25 ft-lb; then tighten the nut on the front through-bolt to 40 ft-lb.

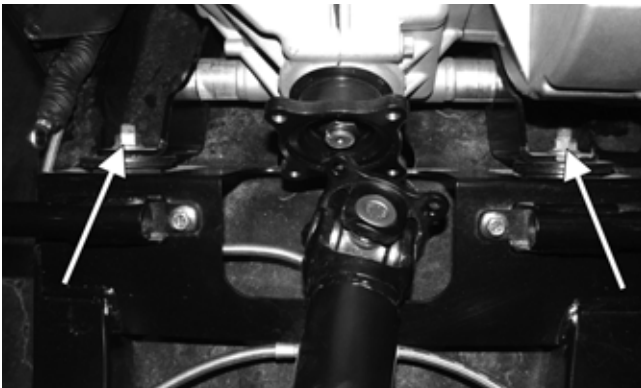

HDX157A

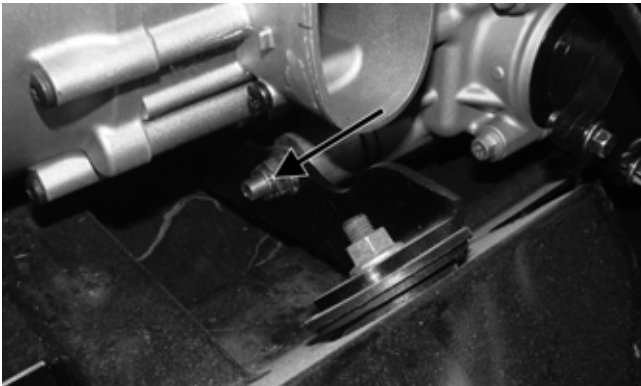

HDX156A

3. Remove the plugs from the oil cooler lines and connect to the appropriate fittings. Secure with hose clamps and tighten securely.
4. Secure the front and rear driveshafts to the engine flanges with the cap screws and tighten to 20 ft-lb; then connect the upper and lower coolant hoses and tighten the clamps securely.
5. Place a new grafoil seal in the cylinder head and a new grafoil seal on the muffler end of the exhaust pipe and install the exhaust pipe. Secure with two exhaust springs and two cap screws tightened to 20 ft-lb.

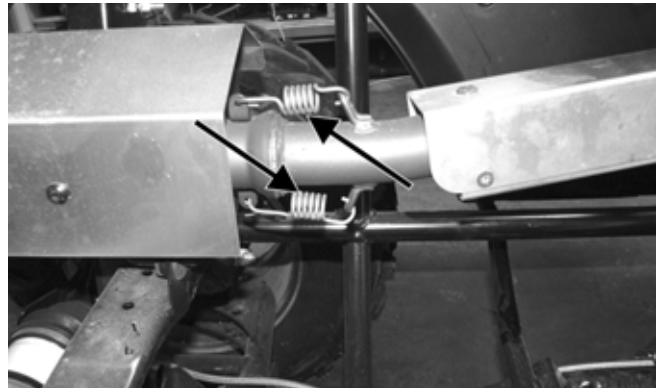

HDX153A

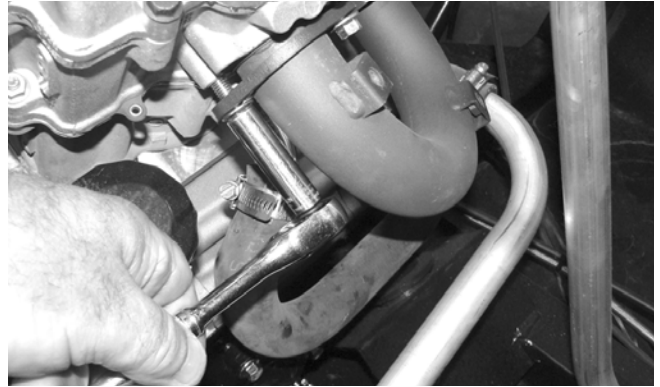

HDX154

6. Install the forward exhaust pipe heat shield and secure with the machine screws. Tighten securely.

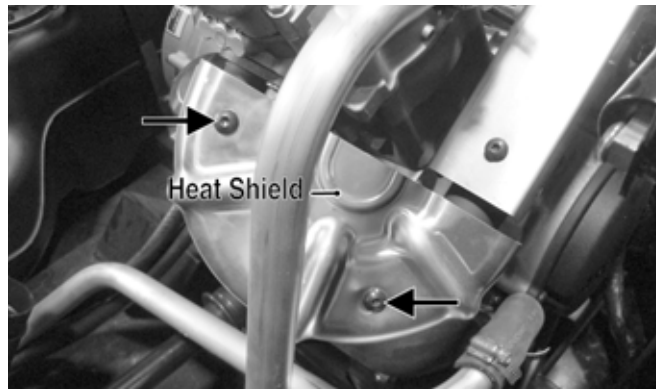

HDX152A

7. Install the CVT cooling ducts on the V-bolt housing and secure with clamps. Tighten securely. Install an appropriate nylon tie to secure the exhaust duct.



HDX135A

8. Install the starter cable to the starter motor, secure with the nut and tighten securely; then secure the engine/harness ground wires to the engine with a cap screw and tighten to 8 ft-lb.

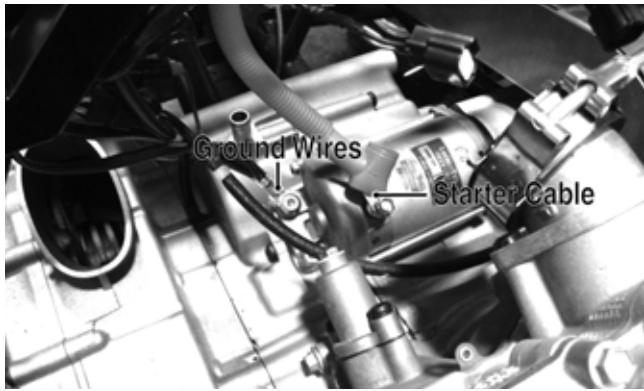

HDX149A

9. Connect the shift cable to the shift arm and install the E-clip; then secure the shift cable bracket to the engine case and tighten the engine case screws to 8 ft-lb.

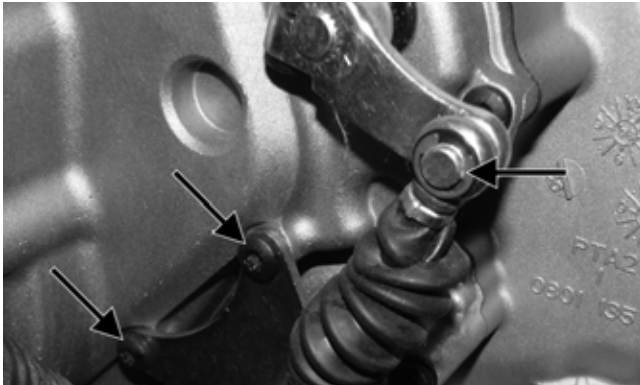

HDX142A

10. On the left side, connect the ECT sensor connector, speed sensor connector, and spark plug cap.



HDX135A



HDX137A

11. Install the throttle body into the intake manifold boot and secure with the clamp. Tighten to 30 in-lb.

12. Install the air filter assembly and secure to the frame with four sheet metal screws; then secure the intake boot with the clamp and tighten securely.



HDX148A

13. Connect the IAT sensor connector to the IAT sensor and the crankcase breather tube to the crankcase; then install the air filter intake tube and secure with a clamp and sheet metal screw.



HDX031A

14. Connect the gasoline hose to the throttle body making sure the gasoline hose connector fully engages and locks onto the fuel rail.

3



HDX138B

15. Connect the MAP sensor connector (A), fuel injector connector (B), ISC connector (C), and TPS connector (D); then install new nylon ties as noted during removing.

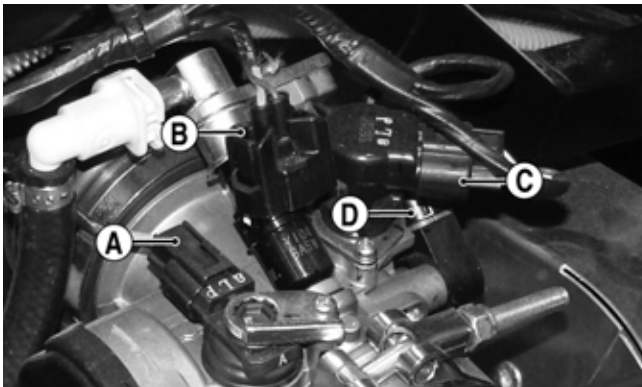

HDX136A

16. Pour the recommended amount of oil and coolant into the engine and radiator; then loosen the coolant bleed screw to allow trapped air to escape. When clear coolant flows, tighten the bleed screw.

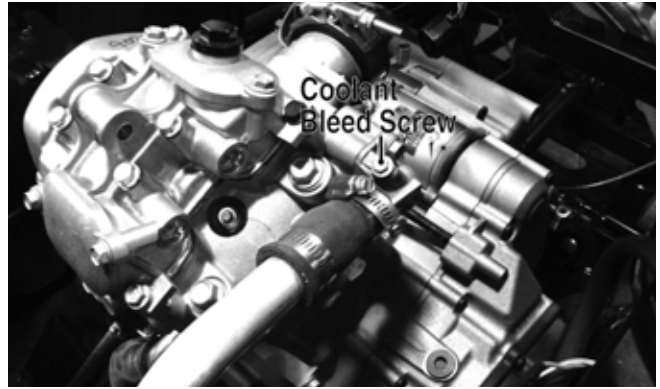

HDX158B

17. Connect the negative battery cable to the battery and install the battery cover.
18. Install the center skid plate, center floorboard, and seat base; then install the seat back and seat.
19. Start the engine and check for leaks allowing to warm up for several minutes; then shut the engine off and check engine oil and coolant levels.

SECTION 4 - FUEL/LUBRICATION/COOLING

TABLE OF CONTENTS

Fuel/Lubrication/Cooling	4-2
Electronic Fuel Injection	4-2
Gas Tank	4-3
Gas/Vent Hoses	4-5
Oil Filter/Oil Pump	4-5
Oil Cooler	4-6
Liquid Cooling System.....	4-6
Radiator.....	4-7
Thermostat	4-8
Fan	4-9
Water Pump	4-9
Electric Fuel Pump/Fuel Level Sensor	4-10
Troubleshooting	4-12

Fuel/Lubrication/Cooling

■NOTE: Some photographs and illustrations used in this section are used for clarity purposes only and are not designed to depict actual conditions.

■NOTE: Critical torque specifications are located in Section 1.

SPECIAL TOOLS

A number of special tools must be available to the technician when performing service procedures in this section. Refer to the current Special Tools Catalog for the appropriate tool description.

Description	p/n
Oil Pressure Test Kit	0644-495
Tachometer	0644-275

■NOTE: Special tools are available from the Arctic Cat Service Parts Department.

Electronic Fuel Injection

⚠ WARNING

Whenever the gasoline hoses are removed (other than for pressure testing), the battery must be disconnected to prevent inadvertent activation of the electronic fuel pump.

⚠ WARNING

Whenever any maintenance or inspection is performed on the fuel system during which there may be fuel leakage, there should be no welding, smoking, open flames, etc., in the area.

TROUBLESHOOTING

1. Verify that the electric fuel pump is operating by listening for a “whirring” sound for approximately three seconds after the ignition switch is turned to the ON position. If no sound can be heard, see Electric Fuel Pump/Fuel Level Sensor in this section.
2. Check for a flashing EFI icon on the LCD. If EFI is flashing, see ECU Error Codes in Section 5.
3. Make sure there is sufficient, clean gas in the gas tank.
4. Verify that the battery is sufficiently charged to crank the engine over at normal speed.
5. Check the air filter housing and air filter for contamination. Clean or replace as necessary (see Section 2).

REMOVING THROTTLE BODY

1. Turn the ignition switch to the OFF position; then remove the ignition switch key.

⚠ WARNING

Do not turn the ignition switch to the ON position with the hoses removed. Gasoline will be pumped by the electric fuel pump causing a safety hazard.

2. Remove the seat, seat back, and seat base; then disconnect the battery.
3. Remove the air inlet boot between the air filter and throttle body; then disconnect the MAP sensor connector (A), fuel injector connector (B), and ISC connector (C).



HDX048A

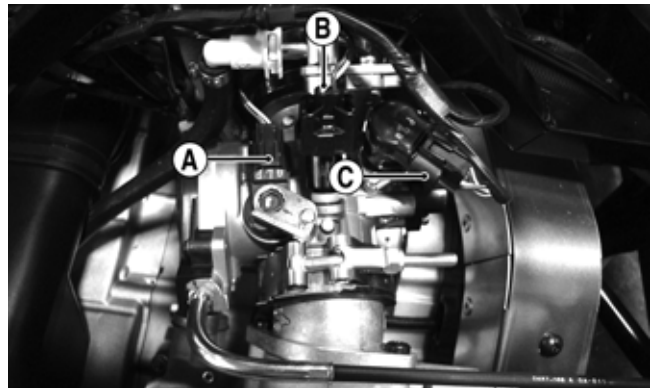

HDX043A

4. Remove the screw from the throttle arm cover and remove the cover; then loosen the jam nut and disconnect the throttle cable.

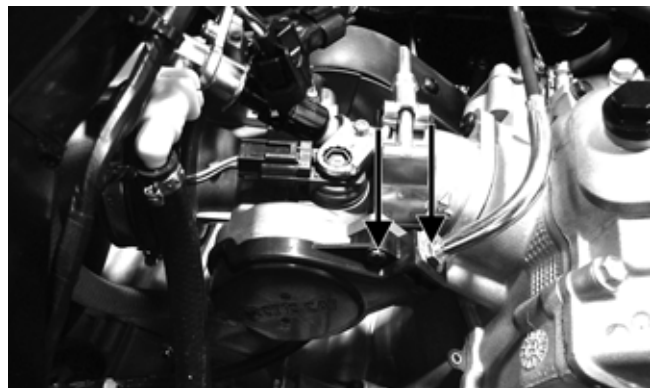

HDX044A

- Slowly disconnect the gasoline hose connector from the fuel rail.

⚠ WARNING

Gasoline may be under pressure. Place an absorbent towel under the connector to absorb any gasoline spray when disconnecting.

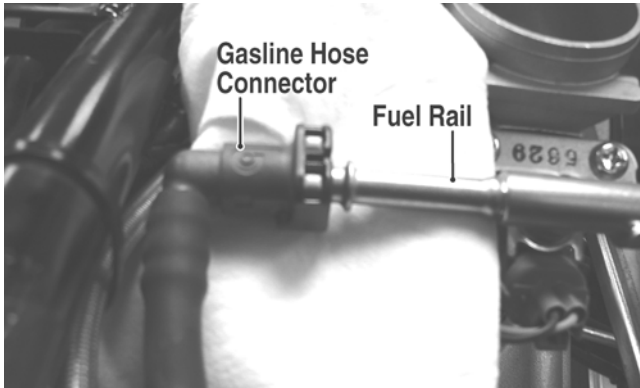

FI092A

- Loosen the clamp securing the throttle body to the intake manifold and remove the throttle body assembly.
- Use tape to cover and seal the intake opening.

CAUTION

Any objects or liquid entering the intake opening will fall into the engine causing severe damage if the engine is turned over or started.

INSTALLING THROTTLE BODY

- Install the throttle body into the intake manifold and secure with the clamp. Tighten to 30 in.-lb.
- Connect the throttle cable to the throttle body and adjust throttle free-play (see Section 2); then connect the gasoline hose.
- Connect the electrical connectors to the throttle body components.
- Install the air filter boot and secure with the existing hardware.
- Install the seat base, seat back, and seat.

Gas Tank

⚠ WARNING

Whenever any maintenance or inspection is made on the fuel system during which there may be fuel leakage, there should be no welding, smoking, open flames, etc., in the area.

REMOVING

- Remove the seat, seat back, and seat base; then remove the floor.

- Disconnect the vent hose (A), gasoline hose (B), and fuel pump/fuel level sensor connector (C); then cap the vent fitting and gas hose fitting.

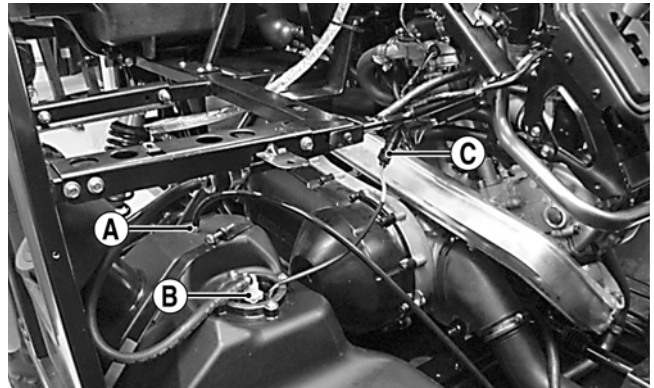

PR698A

- Remove the outer cap screw securing the front tank hold-down; then swing the hold-down to the left.

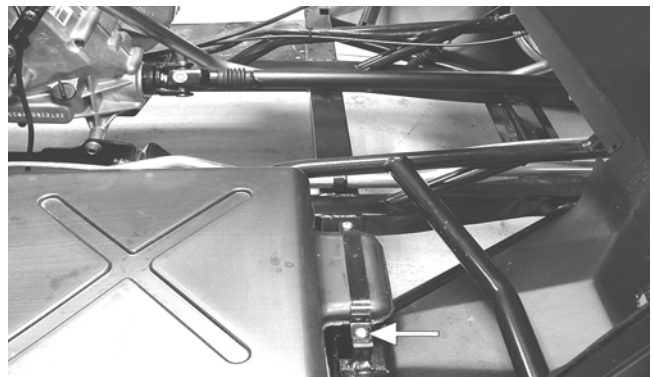

PR167A



PR170

- Remove four press-nuts securing the gas cap inset; then remove the gas cap and inset. Install the gas cap.

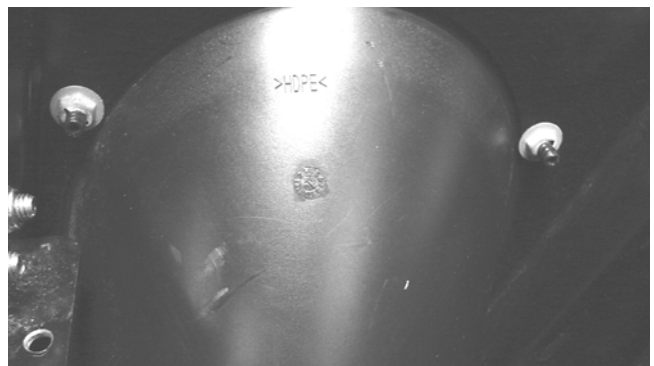

PR168

- Remove the joining cap screw and nut from the rear gas tank hold-down strap; then remove the inside hold-down strap.

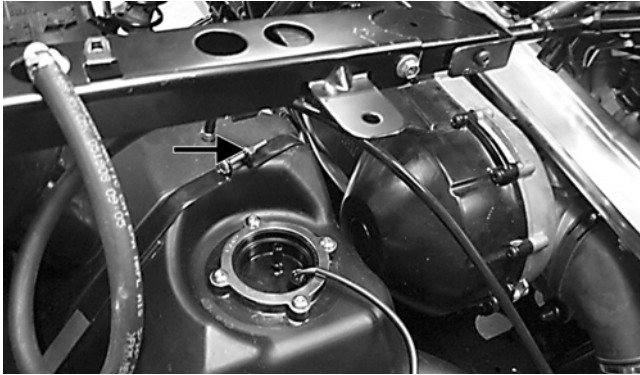

PR699A

- Lift and slide the tank forward raising the front of the tank first; then turn the tank and lift out the right side.

CLEANING AND INSPECTING

■NOTE: Whenever a part is worn excessively, cracked, or damaged in any way, replacement is necessary.

- Clean all gas tank components with parts-cleaning solvent.
- Inspect all hoses for cracks or leaks.
- Inspect gas tank cap and tank for leaks, holes, and damaged threads.
- Inspect the fuel level sensor for proper operation (see Fuel Level Sensor in this section).

INSTALLING

⚠ WARNING

Whenever any maintenance or inspection is made on the fuel system during which there may be fuel leakage, there should be no welding, smoking, open flames, etc., in the area.

- Place the gas tank into position in the vehicle; then install the inside rear hold-down strap.



PR173

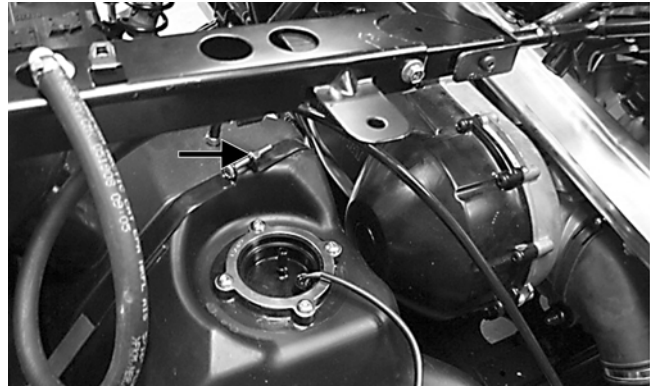

PR699A

- Swing the front hold-down to the right into position and install the cap screw and nut. Do not tighten at this time.



PR171

- Install the rear hold-down strap joining cap screw and nut. Do not tighten at this time.

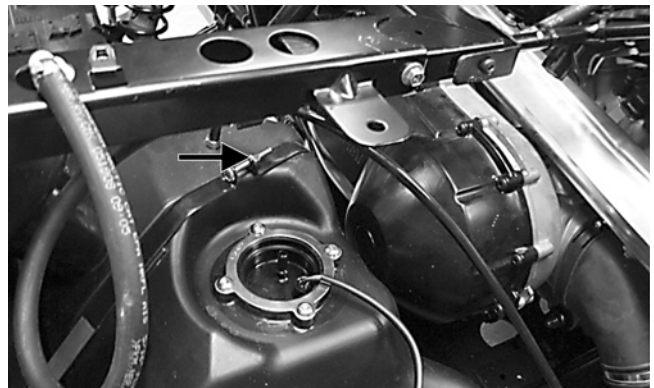

PR699A

- Place the gas cap filler panel into position; then if necessary, position the gas tank so the filler panel and filler neck are not binding or rubbing.



PR176

- Secure the filler panel with four press-nuts; then tighten the hardware securing the hold-down straps (from steps 2-3) securely.

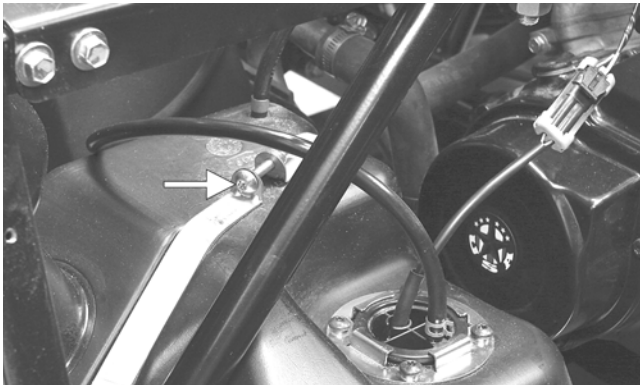

PR166A

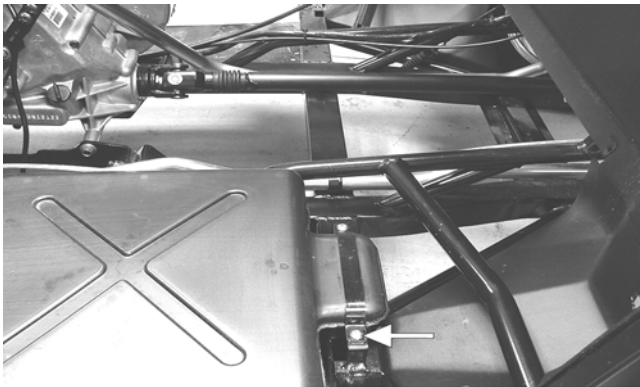

PR167A

- Connect the vent hose (A) and gasoline hose (B) to the proper fittings; then connect the fuel pump/fuel level sensor connector (C) to the main harness.

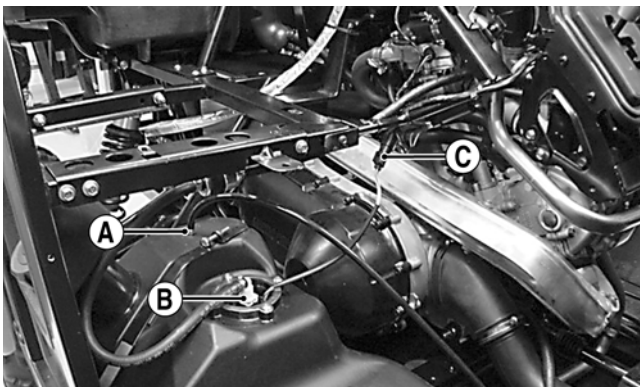

PR698A

- Position the floorboard into the vehicle and secure with the appropriate hardware; then install the seat base, seat back, and seat.

Gas/Vent Hoses

Replace the gas hose every two years. Damage from aging may not always be visible. Do not bend or obstruct the routing of the vent hoses. Make certain the vent hoses are securely connected and the opposite ends are always open.

Oil Filter/Oil Pump

NOTE: Whenever internal engine components wear excessively or break and whenever oil is contaminated, the oil pump should be replaced.

TESTING OIL PUMP PRESSURE

NOTE: The engine must be warmed up to operating temperature (cooling fan cycling) for this test.

- Remove the seat, seat back, and seat base.
- Using a suitable "T" fitting, connect Oil Pressure Test Kit to the oil fitting and hose. Tighten all clamps securely.

NOTE: Some oil seepage may occur when installing the oil pressure gauge. Wipe up oil residue with a cloth.

- Block the wheels, place the transmission in neutral, and start the engine. Allow the engine to warm up to operating temperature (with cooling fan cycling).
- Connect a suitable tachometer. With the engine running at 3000 RPM, the pressure gauge must show 0.7-1.4 kg/cm² (10-20 psi).
- Remove the test kit and tachometer from the vehicle and install the oil hose. Tighten the clamps securely.
- Install the seat base, seat back, and seat.

NOTE: If the oil pressure is lower than specified, check for an oil leak, damaged oil seal, or defective oil pump.

NOTE: If the oil pressure is higher than specified, check for too heavy engine oil weight (see Section 1), clogged oil passage, clogged oil filter, or improper installation of the oil filter.

REMOVING/DISASSEMBLING

- Remove the oil pump from the engine (see Right-Side Components in Section 3).

- Remove the Phillips-head screw on the back side of the pump and separate the pump housing and cover. Note the position of the inner and outer rotors and alignment pin for assembly.
- Remove oil pump components.

CLEANING AND INSPECTING

■NOTE: Whenever a part is worn excessively, cracked, or damaged in any way, replacement is necessary.

- Clean all oil-pump components.
- Inspect the rotors for scoring and gouges.
- Inspect the alignment pin, driveshaft, and driven sprocket for damage.
- Inspect the pump housing and cover for cracks or damage.

ASSEMBLING/INSTALLING

- Place the rotors into the pump housing making sure the alignment pin is in the groove of the rotor.
- Place the cover onto the pump housing.
- Secure the pump cover with the Phillips-head screw coated with red Loctite #271. Tighten to 8 ft-lb.
- Install the oil pump into the engine (see Right-Side Components in Section 3).

Oil Cooler

REMOVING

- Loosen the clamps securing the oil hoses to the oil cooler; then place a shallow pan or absorbent towel under the connection and remove the hoses.

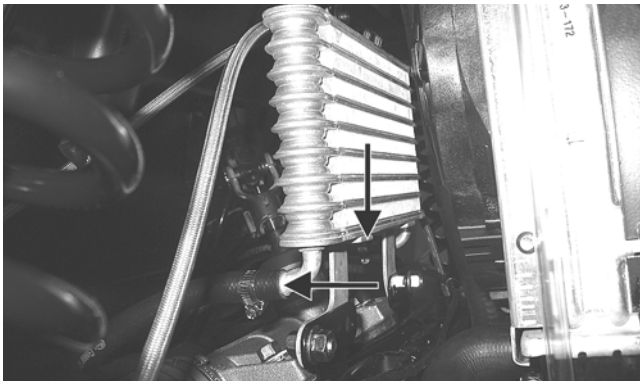

PR484A

- Remove the flange nuts and cap screws from the oil cooler mountings and remove the oil cooler.

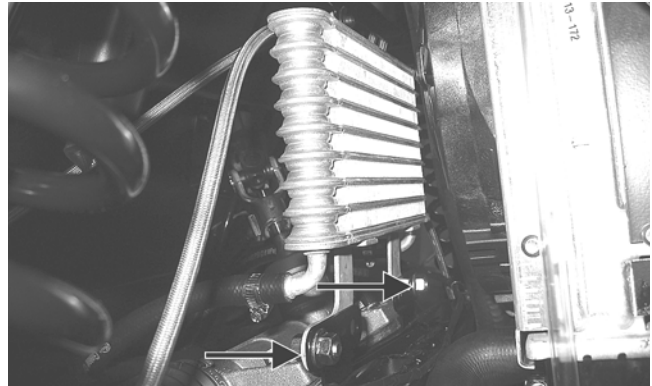

PR484B

CLEANING AND INSPECTING

■NOTE: Whenever a part is worn excessively, cracked, or damaged in any way, replacement is necessary.

- Prior to washing, inspect the oil cooler for signs of leaks such as oily dirt build-up.
- Wash the cooling fins using a garden hose and hot, soapy water and a soft brush.
- Inspect all mounting brackets and the oil inlet and outlet for cracks or bends.

INSTALLING

- Place the oil cooler into position and secure with the existing hardware. Tighten securely.
- Connect the oil hoses and secure with the hose clamps. Tighten securely.

Liquid Cooling System

When filling the cooling system, use premixed Arctic Cat Antifreeze. While the cooling system is being filled, air pockets may develop; therefore, open the bleed screw on the thermostat housing to allow air to bleed from the cooling system. When clear coolant (no bubbles) is present, tighten the bleed screw securely; then fill the cooling system to the bottom of the stand pipe in the radiator neck. Run the engine for five minutes after the initial fill, shut the engine off, and then “top-off” the cooling system to the bottom of the stand pipe in the radiator neck.

CAUTION

After operating the vehicle for the initial 5-10 minutes, stop the engine, allow the engine to cool down, and check the coolant level. Add coolant as necessary.

Radiator

REMOVING

1. Remove the two sheet metal screws securing the dash assembly to the frame (center front).



HDX162A

2. Remove four torx-head screws (A) securing the under-hood storage box to the frame; then remove two cap screws with nuts (B) at the front of the storage box.

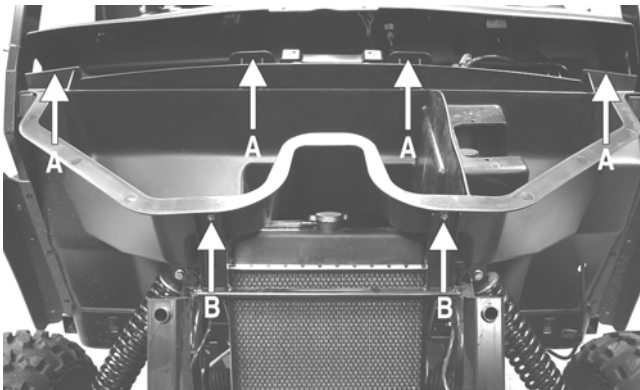

PR182A

3. While lifting up on the front of the storage box, pry the rear center clear of the center dash mount and remove the storage box.



PR186

4. Drain the coolant into a suitable container; then disconnect the cooling fan wire connector from the main harness.

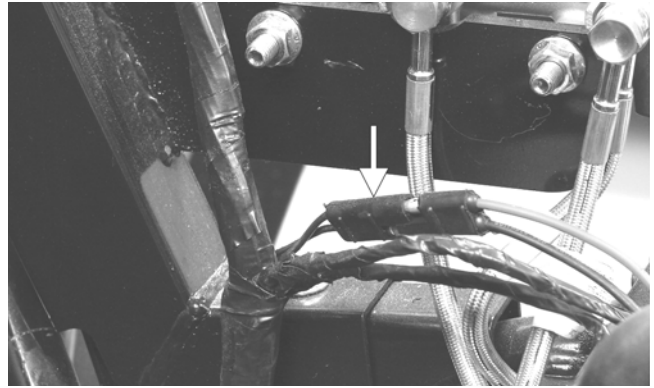

PR183A

5. Remove the two shoulder bolts and nuts securing the radiator to the frame; then disconnect the upper and lower coolant hoses.

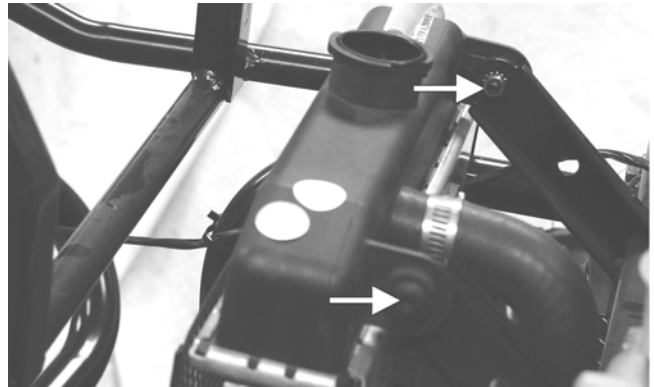

PR184A

6. Lift the radiator assembly from the vehicle. Account for two upper and two lower rubber mounting grommets.

CLEANING AND INSPECTING

■NOTE: Whenever a part is worn excessively, cracked, or damaged in any way, replacement is necessary.

1. Flush the radiator with water to remove any contaminants.
2. Inspect the radiator for leaks and damage.
3. Inspect all hoses for cracks and deterioration.
4. Inspect all fasteners and grommets for damage or wear.

INSTALLING

1. Place the radiator into position making sure the grommets are correctly installed; then secure to the mounts with the two shoulder bolts and nuts. Tighten securely.

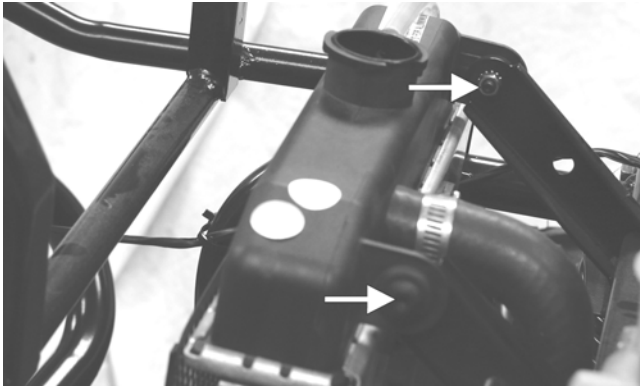

PR184A

2. Connect the upper and lower coolant hoses to the radiator and secure with the appropriate hose clamps; then connect the cooling fan wire connector to the main harness.

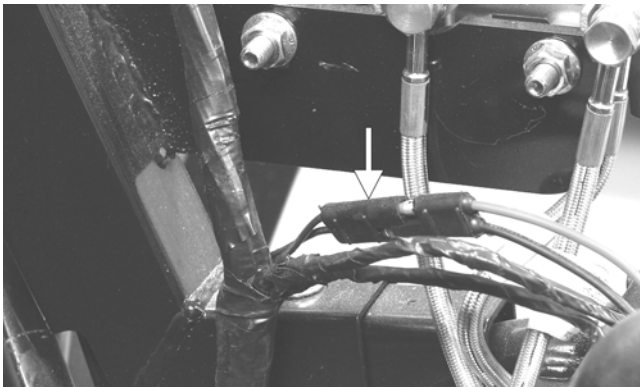

PR183A

3. Open the high-point bleed screw on the thermostat housing to allow trapped air to escape. Tighten securely after filling.
4. Pour the recommended coolant into the radiator and secure the radiator cap.
5. Place the storage box into position and using a smooth, flat pry-bar, pry the center of the box past the dash mount; then secure with the appropriate fasteners.



PR187

6. Install the two sheet metal screws in the dash. Tighten securely.
7. Start the engine and warm up to operating temperature; then verify the coolant level is at the bottom of the stand pipe in the radiator neck. Add coolant as necessary.

Thermostat

REMOVING

1. Drain approximately one quart of coolant from the cooling system.
2. Remove the two cap screws securing the thermostat housing to the cylinder head. Account for a thermostat with seal.

INSPECTING

■NOTE: Whenever a part is worn excessively, cracked, or damaged in any way, replacement is necessary.

1. Inspect the thermostat for corrosion, wear, or spring damage.
2. Using the following procedure, inspect the thermostat for proper operation.
 - A. Suspend the thermostat in a container filled with water.
 - B. Heat the water and monitor the temperature with a thermometer.
 - C. The thermostat should start to open at 71.0-86.0° C (160-187° F).
 - D. If the thermostat does not open, it must be replaced.
3. Inspect all coolant hoses, connections, and clamps for deterioration, cracks, and wear.

■NOTE: All coolant hoses and clamps should be replaced every four years or 4000 miles.

INSTALLING

1. Place the thermostat with seal into the thermostat housing; then secure the thermostat housing to the cylinder head with the two cap screws.

CAUTION

When installing the thermostat, make sure the bleed holes are straight up and down or air will remain trapped causing engine damage due to overheating.

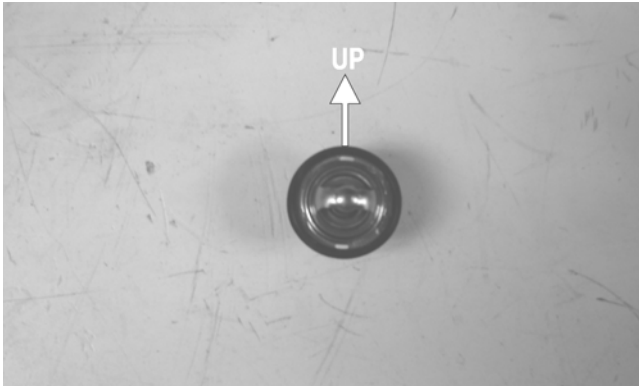

PR281A

2. Fill the cooling system with the recommended amount of antifreeze. Check for leakage.

Fan

REMOVING

1. Remove the radiator (see Radiator in this section).
2. Remove the fan assembly from the radiator.

INSTALLING

1. Position the fan assembly on the radiator; then secure with existing hardware.

■ **NOTE:** The fan wiring must be in the upper-right position.

2. Install the radiator (see Radiator in this section).

Water Pump

■ **NOTE:** The water pump is not a serviceable component. If the pump is defective or if the mechanical seal is leaking (coolant dripping from the discharge hole), the water pump must be replaced.

REMOVING

1. Remove the radiator cap; then remove the water pump coolant drain plug and drain the coolant.



PR122A

2. Drain the oil from the engine/transmission.
3. Remove the seats and center console; then remove the right-side seat-base.
4. Loosen the coolant hose clamps and slide the clamps away from the hose ends.



PR132

5. Remove the two cap screws securing the water pump to the engine; then remove the water pump.

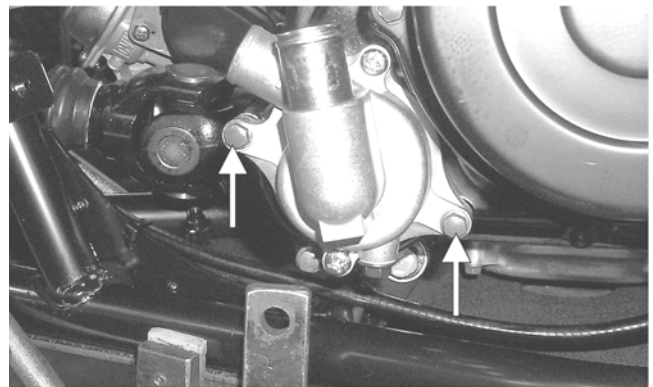

CC786A

INSTALLING

1. Secure the water pump to the engine with the two cap screws tightened securely.

4

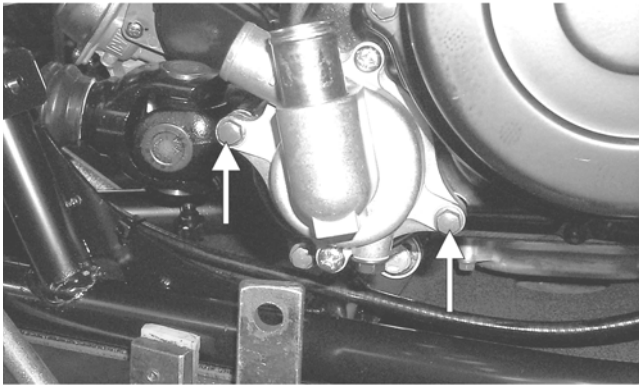

CC786A

2. Connect the two coolant hoses to the water pump and secure with the clamps; then install the water pump coolant drain plug.



PR132

3. Fill the engine/transmission with the proper amount of recommended oil.
4. Open the coolant bleed screw and fill the cooling system with the proper amount of recommended coolant. Close the bleed screw and tighten when no more air is present.

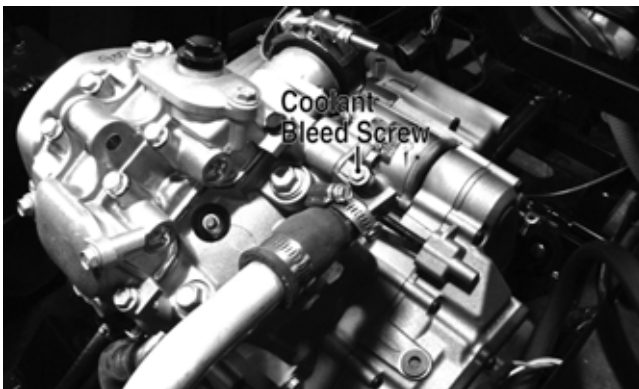

HDX158B

■**NOTE:** While the cooling system is being filled, air pockets may develop; therefore, run the engine for five minutes after the initial fill, shut the engine off, and then fill the cooling system.

5. Check the entire cooling system for leakage.

CAUTION

After operating the vehicle for the initial 5-10 minutes, stop the engine, allow the engine to cool down, and check the coolant level. Add coolant as necessary.

6. Install the seat base, seat back, and seat.

Electric Fuel Pump/Fuel Level Sensor

The electric fuel pump and fuel level sensor are not serviceable components. If either component fails, it must be replaced.

TESTING

⚠ WARNING

Whenever any maintenance or inspection is made on the fuel system during which there may be fuel leakage, there should be no welding, smoking, open flames, etc., in the area.

👉 AT THIS POINT

Prior to removing the electric fuel pump, the following check should be performed to determine that removal is necessary.

1. Turn the ignition switch ON and listen for a momentary “whirring” sound of the pump building pressure. If the sound is heard (10 seconds), no electrical checks are necessary. Turn the ignition switch OFF.
2. Disconnect the gasoline hose from the fuel rail; then install a suitable pressure gauge.

⚠ WARNING

Gasoline may be under pressure. Place an absorbent towel under the connector to absorb any gasoline spray when disconnecting.

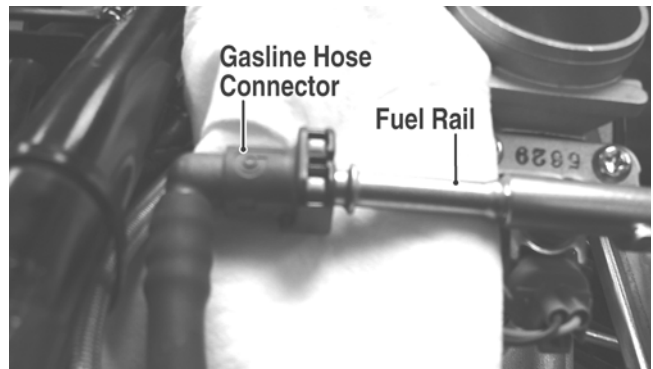

FI092A

3. Turn the ignition switch to the ON position. The fuel pressure should build until the pump shuts off. Pressure should read 3.0 kg-cm² (43 psi).

- If the pump is not running, disconnect the fuel pump/sensor connector by reaching under the rear rack from behind.
- Connect a multimeter to the power supply leads with the red tester lead to the red wire and the black tester lead to the black wire; then turn the ignition switch to the ON position. The meter should read battery voltage. If battery voltage is indicated and the fuel pump does not run, replace the pump assembly. If no battery voltage is indicated, check the ECU and the vehicle tilt sensor.

REMOVING

- Remove the key from the ignition switch.

⚠ WARNING

Always ensure that power cannot be inadvertently applied to the ignition/ECU when working on the fuel system. If the ignition switch is turned on, the electric fuel pump will start and gas could be rapidly pumped and spilled resulting in fire and severe injury.

- Remove the seat, seat back, and seat base; then disconnect the negative battery cable.
- Disconnect the electrical plug from the main harness; then disconnect the gasline hose from the fuel pump.
- Mark the fuel pump mounting and gas tank for installing purposes; then remove the screws securing the fuel pump to the gas tank and remove the fuel pump.

CAUTION

Take care not to damage the float or float arm or replacement of the entire assembly will be necessary.

- Using duct tape or other suitable means, cover the fuel pump opening.

INSPECTING

🔧 AT THIS POINT

If the pump has failed earlier test and must be replaced, proceed to INSTALLING.

- Inspect the fuel screen and blow clean with low pressure compressed air.
- Move the float lever and check for free movement. The float assembly should return to the lower position without force. If not, replace the fuel level sensor assembly.
- Test the fuel level sensor by connecting a multimeter (A) to the fuel level sensor leads (B); then select OHMS. The multimeter should show 5 ohms at full fuel position (C) and 95 ohms at empty fuel position (D).

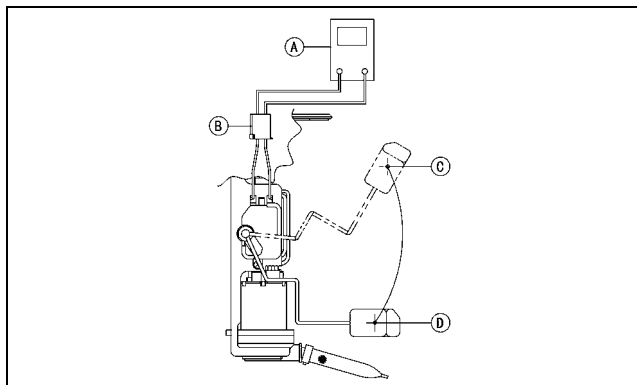

ATV2116

■NOTE: If readings are erratic, clean the resistor wiper and resistor with clean alcohol and retest. If still not correct, replace the fuel level sensor.

- To replace the fuel level sensor, use the following procedure.

A. Disconnect the two-wire connector (A); then press the fuel level sensor toward the top of the fuel pump to release it from the mounting slot (B).

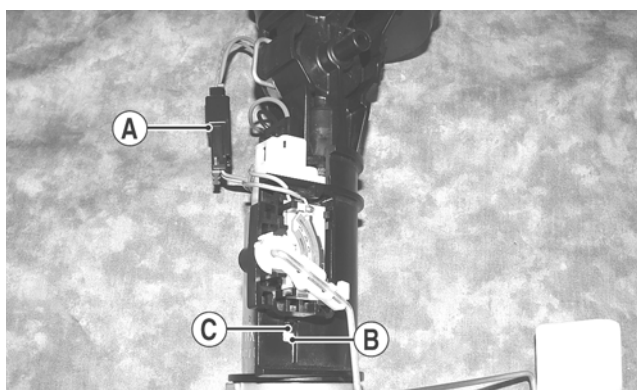

FI460A

B. Engage the tabs (C) of the fuel level sensor into the mounting slot (B) and press toward the bottom of the fuel pump to latch in place; then connect the two-wire connector (A).

INSTALLING

- Place the fuel pump assembly into the gas tank with a new gasket aligning the match marks; then secure with the four screws. Tighten securely.

■NOTE: It is important to install the fuel pump with the correct orientation to ensure adequate float lever clearance.

- Connect the gasline hose to the fuel pump pipe and secure with the hose clamp; then connect the electrical plug to the main harness.
- Connect the negative battery cable; then turn the ignition switch to the ON position and verify that no gas leaks are present, the pump runs for 2-3 seconds, and the gas gauge reading is normal.
- Start the engine to verify proper engine operation; then shut off the engine and install the seat base, seat back, and seat.

4

Troubleshooting

Problem: Starting impaired	
Condition	Remedy
1. Gas contaminated	1. Drain gas tank and fill with clean gas
Problem: Idling or low speed impaired	
Condition	Remedy
1. TPS out of adjustment	1. Adjust TPS
Problem: Medium or high speed impaired	
Condition	Remedy
1. High RPM "cut out" against RPM limiter	1. Decrease RPM speed

SECTION 5 - ELECTRICAL SYSTEM

TABLE OF CONTENTS

Electrical System.....	5-2
Specifications	5-2
Battery.....	5-2
RPM Limiter.....	5-3
Testing Electrical Components.....	5-3
Switches.....	5-3
Electrical Connections.....	5-3
Accessory Receptacle/Connector	5-4
Brakelight Switch.....	5-4
Engine Coolant Temperature (ECT) Sensor.....	5-4
Fan Motor	5-5
Power Distribution Module (PDM)	5-5
Ignition Coil	5-6
EFI Sensors/Components	5-6
Speed Sensor	5-7
Electronic Power Steering (EPS).....	5-7
Ignition Switch	5-9
Headlight Switch	5-9
Drive Select Switch	5-9
Reverse Override Switch.....	5-10
Front Drive Actuator	5-10
Stator Coil/Crankshaft Position (CKP) Sensor	5-11
Starter Motor	5-11
Starter Relay	5-12
Electronic Control Unit (ECU).....	5-12
Regulator/Rectifier.....	5-13
Headlights	5-13
Taillight-Brakelight	5-13
Ignition Timing.....	5-13
ECU Error Codes	5-14
Tilt Sensor	5-14
Throttle Position Sensor (TPS).....	5-16
Troubleshooting	5-18

Electrical System

■NOTE: Some photographs and illustrations used in this section are used for clarity purposes only and are not designed to depict actual conditions.

SPECIAL TOOLS

A number of special tools must be available to the technician when performing service procedures in this section. Refer to the current Special Tools Catalog for the appropriate tool description.

Description	p/n
Fluke Model 73 Multimeter	0644-191
Fluke Model 77 Multimeter	0644-559
Timing Light	0644-296
MaxiClips	0744-041
Peak Voltage Reading Adapter	0644-307
Test Plug/Error Code List	0444-216

■NOTE: Special tools are available from the Arctic Cat Service Parts Department.

Specifications

Spark Plug Type	NGK CPR8E
Spark Plug Gap	0.7-0.8 mm (0.028-0.032 in.)
Spark Plug Cap	5000 ohms
Ignition Coil Resistance (primary)	Less than 1 ohm (terminal (+) to ground (-))
(secondary)	12k-19k ohms (high tension - plug cap to terminal (+))
Ignition Coil Primary Voltage	Battery Voltage (orange (+) to blue/white (-))
Stator Coil Resistance (crankshaft position sensor) (AC generator)	150-250 ohms (blue to green) Less than 1 ohm (yellow to yellow)
Crankshaft Position Sensor AC Voltage	2.0 or more (blue to green)
AC Generator Output (no load)	60 AC volts @ 5000 RPM (yellow to yellow)
Ignition Timing	10° BTDC @ 1500 RPM

Battery

■NOTE: To access the battery box, the seat must be removed.

After being in service, batteries require regular cleaning and recharging in order to deliver peak performance and maximum service life. The following procedures are recommended for cleaning and maintaining lead-acid batteries. Always read and follow instructions provided with battery chargers and battery products.

⚠ WARNING

Any time service is performed on a battery, the following must be observed: keep sparks, open flame, cigarettes, or any other flame away. Always wear safety glasses. Protect skin and clothing when handling a battery. When servicing battery in enclosed space, keep the area well-ventilated. Make sure battery venting is not obstructed.

1. Remove the battery hold-down; then disconnect the battery cables (negative cable first).
2. Disconnect the vent hose.
3. Remove the battery from the vehicle; then thoroughly wash the battery and battery compartment with soap and water.

■NOTE: If battery posts, cable ends, or the battery case has a build-up of white/green powder residue, apply water and baking soda to neutralize acid; then flush off with warm soapy water.

4. Using a wire brush, clean the battery posts and cable ends removing all corrosive buildup. Replace damaged cables or cable ends.
5. Add clean distilled water to bring fluid level to the UPPER level line.

⚠ WARNING

Battery acid is harmful if it contacts eyes, skin, or clothing. Care must be taken whenever handling a battery.

CAUTION

Never use electrolyte (sulfuric acid) to "top off" the battery. Use only distilled water or severe battery damage may occur.

6. Using a multimeter, test the battery voltage. The meter must read at least 12.5 DC Volts for a fully charged battery.

■NOTE: At this point, if the meter reads as specified, the battery may be returned to service (see step 10).

7. If the meter reads less than specified voltage, charge the battery using the following guidelines.

- A. When using an automatic battery charger, always follow the charger manufacturer's instructions.
- B. When using a constant-current battery charger, use the following Battery Charging Chart.

CAUTION

Never exceed the standard charging rate.

⚠ WARNING

An overheated battery could explode causing severe injury or death. Always monitor charging times and charge rates carefully. Stop charging if the battery becomes very warm to the touch. Allow it to cool before resuming charging.

Battery Charging Chart (Constant-Current Charger)

Battery Voltage (DC)	Charge State	Charge Time Required (at 1.5-2.0 Amps)
12.5 or more	100%	None
12.2-12.4	75%-99%	3-6 hours
12.0-12.2	50%-74%	5-11 hours
11.0-11.9	25%-49%	13 hours (minimum)
11.5 or less	0-24%	20 hours (minimum)

■NOTE: If the battery voltage is 11.5 DC Volts or less, some chargers may “cut off” and fail to charge. If this occurs, connect a fully charged booster battery in parallel (positive to positive and negative to negative) for a short period of time with the charger connected. After 10-15 minutes, disconnect the booster battery leaving the charger connected and the charger should continue to charge. If the charger “cuts off,” replace the battery.

- After charging the battery for the specified time, remove the battery charger and allow the battery to sit for 1-2 hours.
- Connect the multimeter and test the battery voltage. The meter should read at least 12.5 DC Volts. If the voltage is as specified, the battery is ready for service.

■NOTE: If voltage in step 9 is below specifications, charge the battery an additional 1-5 hours; then retest. Recheck electrolyte level and the battery is ready for service.

- Place the battery in the battery compartment; then coat the battery posts and cable ends with a light coat of multi-purpose grease.

CAUTION

Before installing the battery, make sure the ignition switch is in the OFF position.

- Connect the battery cables (positive cable first); then install the battery hold-down.

CAUTION

Connecting cables in reverse (positive to negative and negative to positive) can cause serious damage to the electrical system.

- Install the seat.

RPM Limiter

■NOTE: The ROV is equipped with an ECU that retards ignition timing when maximum RPM is approached. When the RPM limiter is activated, it could be misinterpreted as a high-speed misfire.

Testing Electrical Components

All of the electrical tests should be made using the Fluke Model 73 Multimeter or Model 77 Multimeter and when testing peak voltage, the Peak Voltage Reading Adapter must be used. If any other type of meter is used, readings may vary due to internal circuitry. When troubleshooting a specific component, always verify first the fuse(s) are good, the bulb(s) are good, the connections are clean and tight, the battery is fully charged, and all appropriate switches are activated.

■NOTE: For absolute accuracy, all tests should be made at room temperature of 68° F.

Switches

5

Each time the vehicle is used, switches should be checked for proper operation. Use the following list for reference.

- Ignition/start switch — engine will run; starter will engage.
- Drive select switch — differential will engage (4WD)/disengage (2WD).
- Reverse/neutral/high/low switch — R/N/H/L will be indicated on the LCD.
- Headlight switch — high beam, low beam, and lights off can be selected.
- Brake switch — brakelight illuminates and starter can be engaged with vehicle in gear.

Electrical Connections

The electrical connections should be checked periodically for proper function. In case of an electrical failure, check fuses, connections (for tightness, corrosion, damage), and/or bulbs.

Accessory Receptacle/Connector

■NOTE: This test procedure is for either the receptacles or the connectors.

VOLTAGE

1. Turn the ignition switch to the ON position; then set the meter selector to the DC Voltage position.
2. Connect the red tester lead to the red/white wire or the positive connector; then connect the black tester lead to ground.
3. The meter must show battery voltage.

■NOTE: If the meter shows no battery voltage, troubleshoot the battery, fuse, receptacle, connector, or the main wiring harness.

Brakelight Switch

The switch connector is the two-prong black connector below the master cylinder.

■NOTE: The ignition switch must be in the ON position.

VOLTAGE (Wiring Harness Connector)

1. Set the meter selector to the DC Voltage position.
2. Connect the red tester lead to the orange wire; then connect the black tester lead to ground.

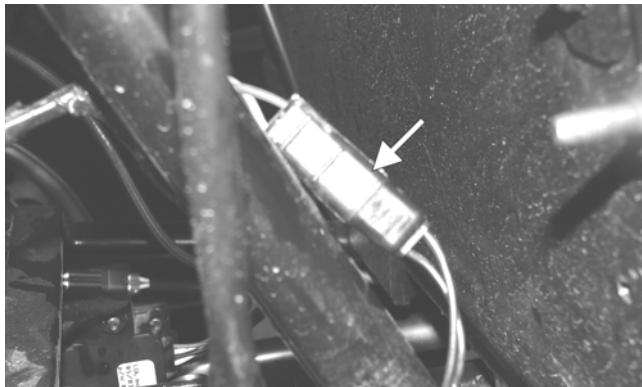

PR276A

3. The meter must show battery voltage.

■NOTE: If the meter shows no battery voltage, troubleshoot the battery, fuse, switch, or the main wiring harness.

■NOTE: If the meter shows battery voltage, the main wiring harness is good; proceed to test the switch/component, the connector, and the switch wiring harness for resistance.

RESISTANCE (Switch Connector)

CAUTION

Always disconnect the battery when performing resistance tests to avoid damaging the multimeter.

■NOTE: The brake pedal must be depressed for this test.

1. Set the meter selector to the OHMS position.
2. Connect the red tester lead to one black wire; then connect the black tester lead to the other black wire.



AR621D

3. When the lever is depressed, the meter must show less than 1 ohm.

■NOTE: If the meter shows more than 1 ohm of resistance, replace the switch.

Engine Coolant Temperature (ECT) Sensor

1. Connect the meter leads (selector in OHMS position) to the sensor terminals.
2. Suspend the sensor and a thermometer in a container of cooking oil; then heat the oil.

■NOTE: Neither the sensor nor the thermometer should be allowed to touch the bottom of the container or inaccurate readings will occur. Use wire holders to suspend the sensor and thermometer.

⚠ WARNING

Wear insulated gloves and safety glasses. Heated oil can cause severe burns.

3. On the ECT sensor when the temperature reaches 40° C (104° F), the meter should read approximately 1136 ohms.
4. On the ECT sensor when the temperature reaches 100° C (212° F), the meter should read approximately 155 ohms.
5. If the readings are not as indicated, the sensor must be replaced.
6. Install the sensor and tighten securely.
7. Connect the leads.

Fan Motor

RESISTANCE (Fan Motor Connector)

1. Set the meter selector to the OHMS position.
2. Connect the red tester lead to the red wire; then connect the black tester lead to the black wire.

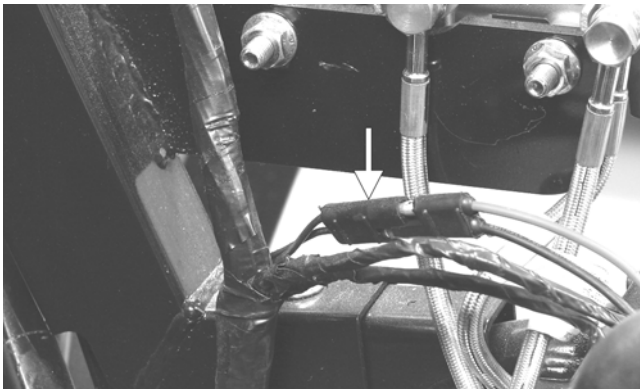

PR183A

3. The meter must show less than 1 ohm.

■NOTE: If the meter shows more than 1 ohm of resistance, troubleshoot or replace the fan motor.

■NOTE: To determine if the fan motor is good, connect the red wire from the fan connector to a 12 volt battery; then connect the black wire from the fan connector to ground. The fan should operate.

⚠ WARNING

Care should be taken to keep clear of the fan blades.

Power Distribution Module (PDM)

■NOTE: The module and wiring harness are not a serviceable component and must be replaced as an assembly.

If there is any type of electrical system failure, always check the fuses first.

■NOTE: The fuses are located in a power distribution module under the operator's seat.

1. Remove all fuses from the power distribution module.

■NOTE: To remove a fuse, compress the locking tabs on either side of the fuse case and lift out.

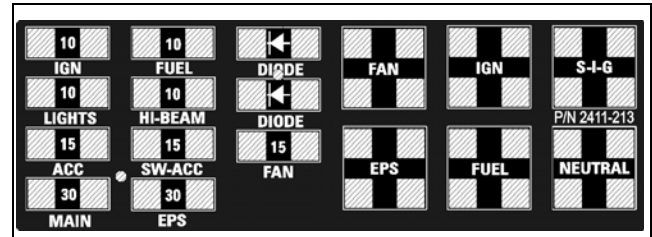

2411-213

CAUTION

Always replace a blown fuse with a fuse of the same type and rating.

■NOTE: Make sure the fuses are returned to their proper position according to amperage. Refer to the amperage listed under each fuse on the power distribution module.

2. Set the meter selector to the DC Voltage position.
3. Connect the black tester lead to ground.
4. Using the red tester lead, contact each end of the fuse holder connector terminals individually.
5. The meter must show battery voltage from one side of the connector terminal ends.

■NOTE: Battery voltage will be indicated from only one side of the fuse holder connector terminal; the other side will show no voltage.

■NOTE: When testing the HI fuse holder, the headlight OFF/HI/LO switch must be in the HI position; when testing the LIGHTS fuse holder, the headlight dimmer switch can be in either the HI or the LO position.

■NOTE: If the meter shows no battery voltage, troubleshoot the battery, switches, power distribution module, or the main wiring harness.

RELAYS

The 4-pin relays are identical plug-in type located on the power distribution module. Relay function can be checked by switching relay positions. The 4-pin relays are interchangeable.

Ignition Coil

The ignition coil is mounted on the fuel pump mounting plate adjacent to the fuel pump.

VOLTAGE (Primary Side)

See Primary Coil in this sub-section.

RESISTANCE

CAUTION
Always disconnect the battery when performing resistance tests to avoid damaging the multimeter.

Always disconnect the battery when performing resistance tests to avoid damaging the multimeter.

■NOTE: For these tests, the meter selector should be set to the OHMS position.

Primary Winding

1. Connect the red tester lead to the terminal (with the wire removed); then connect the black tester lead to ground.

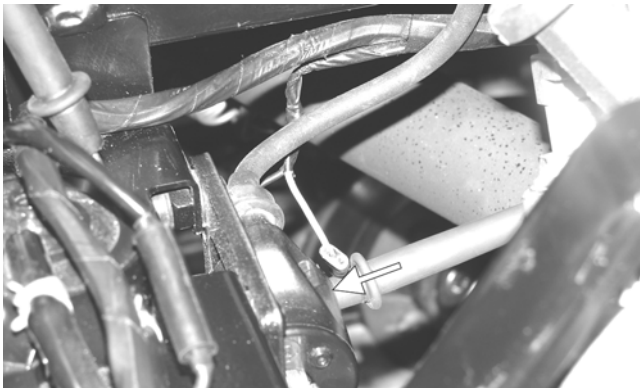

PR278A

2. The meter reading must be within specification.

Secondary Winding

1. Connect the red tester lead to the high tension lead (with the plug cap removed); then connect the black tester lead to ground.
2. The meter reading must be within specification.

■NOTE: If the meter does not show as specified, replace ignition coil.

Spark Plug Cap

1. Connect the red tester lead to one end of the cap; then connect the black tester lead to the other end of the cap.

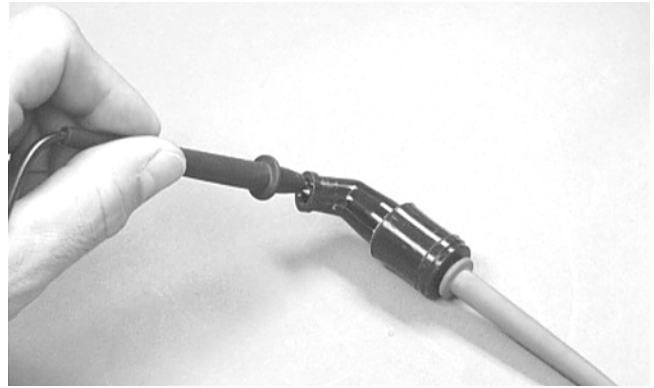

AR603D

2. The meter reading must be within specification.

■NOTE: If the meter does not show as specified, replace the spark plug cap.

VOLTAGE

Primary Coil

1. Set the meter selector to the DC Voltage position; then disconnect the two wires from the coil.

■NOTE: The coil is located to the right of the engine and may be accessed from behind the right-side seat with the cargo box raised.

2. Connect the red tester lead to the orange wire and the black tester lead to the blue/white wire.
3. Turn the ignition switch to the ON position. The meter must show battery voltage.

EFI Sensors/Components

CRANKSHAFT POSITION (CKP) SENSOR

To test the CKP sensor, see Stator Coil/Crankshaft Position (CKP) Sensor in this section.

MANIFOLD ABSOLUTE PRESSURE (MAP) SENSOR

1. Disconnect the MAP connector from the pressure sensor located on the throttle body.
2. Select DC Voltage on the tester and turn the ignition switch to the ON position.
3. Connect the black tester lead to the black/green wire and the red tester lead to the orange/blue wire. The meter should read 4.5-5.5 DC volts. If the meter does not read as specified, check the ECU connector or wiring.
4. Connect the MAP to the harness; then using Maxi-Clips, connect the red tester lead to the brown/white wire and the black tester lead to the black/green wire. With the engine running at idle speed, the meter should read approximately 1.5 DC volts.

■NOTE: If the meter does not read as specified, replace the sensor.

Speed Sensor

■NOTE: Prior to testing the speed sensor, inspect the three-wire connector on the speed sensor for contamination, broken pins, and/or corrosion.

1. Set the meter selector to the DC Voltage position.
2. With appropriate needle adapters on the meter leads, connect the red tester lead to the voltage lead (V); then connect the black tester lead to the ground lead (G).

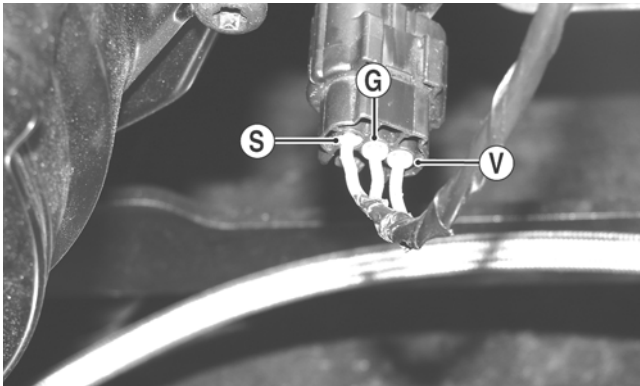

PR279A

3. Turn the ignition switch to the ON position.
4. The meter must show approximately 6 DC volts.
5. Leave the black tester lead connected; then connect the red tester lead to the signal lead pin (S).
6. Slowly move the vehicle forward or backward; the meter must show 0 and approximately 6 DC volts alternately.

■NOTE: If the sensor tests are within specifications, the speedometer must be replaced (see Section 9).

To replace a speed sensor, use the following procedure.

1. Disconnect the three-wire connector from the speed sensor harness or from the speed sensor; then remove the Allen-head cap screw securing the sensor to the sensor housing.
2. Remove the sensor from the sensor housing accounting for an O-ring.

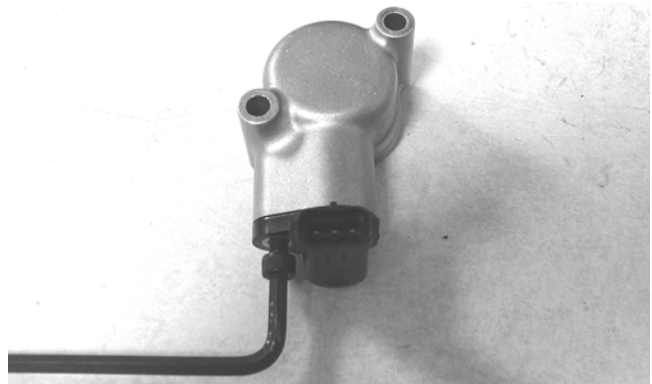

CD070

3. Install the new speed sensor into the housing with new O-ring lightly coated with multi-purpose grease; then secure the sensor with the Allen-head cap screw (threads coated with blue Loctite #242). Tighten securely.

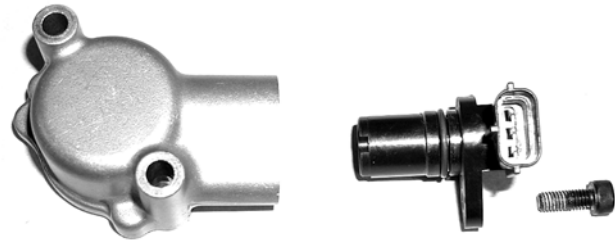

CD071

Electronic Power Steering (EPS)

The electronic power steering (EPS) system is an electro-mechanical device that utilizes 12 volt DC power to drive a motor linked to the steering shaft to assist the driver when rotating the steering wheel. Driver steering inputs are detected by a torque-sensing transducer assembly within the EPS housing. These inputs are converted to electronic signals by the transducer and control circuitry to tell the motor which way to drive the steering shaft. When no steering input (pressure on the steering wheel) is detected, no torque signal is generated, and no steering assist is provided by the motor.

The EPS system is battery-system powered; therefore, the battery must be in good condition and fully charged. Power delivery and overload protection is provided by an EPS relay and 30-amp fuse, located under the seat in the Power Distribution Module (PDM).

If a system malfunction occurs, a malfunction code "P0635" will be displayed on the LCD gauge. Initially, the gauge will go blank for 30 seconds and the code will flash; then the gauge will return to normal except the code will continue to be displayed.

The following is a list of conditions that can generate a malfunction code. All conditions with the exception of item 5 are external to the EPS assembly and therefore can be cleared without replacement of the EPS assembly. Make sure to thoroughly troubleshoot the entire system before replacing the EPS assembly.

■NOTE: The EPS assembly is not serviceable and no service parts or parts lists are available. The EPS is only serviceable as an assembly and must not be disassembled or EPS warranty will be voided.

CAUTION

Do not attempt to check resistance of the EPS motor (2-pin input receptacle). There are internal capacitors holding a charge that can cause internal damage to an ohmmeter.

Malfunction code P0635 will appear if one of the following six conditions occur:

1. Battery system power failure:
 - A. 30 amp EPS fuse blown
 - B. EPS relay failure
 - C. EPS voltage less than 8.5 DC volts for more than two seconds
2. Ignition switch ON for more than five minutes with the engine not running.
3. Vehicle Speed Signal Malfunction (engine speed must exceed 2700 RPM for more than 60 seconds to generate a malfunction code - timer resets if engine drops below 2700 RPM).
 - A. Diode defective (open or shorted)
 - B. Diode not installed
 - C. Diode installed in reverse
 - D. Speed sensor defective
 - E. Speed sensor signal erratic
 - F. Speed sensor signal present but without engine speed signal
 - G. Speed sensor power from LCD gauge interrupted
 - H. Incorrect LCD gauge installed
4. Engine Speed Signal Malfunction (vehicle speed must exceed 5 MPH for more than two seconds - timer resets if speed drops below 5 MPH).
 - A. No engine speed signal
 - B. Erratic engine speed signal
5. EPS Control Circuit Malfunction

The following procedures may be helpful in determining the source of a malfunction code:

Condition: Ignition Key Switch ON and NO EPS assist when moving the handlebar. Code "P0635" flashing.

■NOTE: Prior to troubleshooting below, make sure that Ignition Key Switch has not been left on with the engine not started. After five minutes, this will deactivate the EPS and display the malfunction code. Turn Ignition Key Switch OFF and back to ON to reset and reactivate the EPS. If code and symptom persists, continue as follows:

1. Check 30 amp EPS fuse.
2. Check EPS relay (may be switched with any other 4-pin relay on PDM - replace relay if EPS normal after switching).
3. Disconnect 2-pin connector on the EPS assembly and connect a volt meter set to DC voltage to the harness (black meter lead to BLK and red meter lead to ORG/BRN) With the ignition switch to the ON position, the meter must read more than 8.5 DC volts (if correct voltage is not present, check connections and wiring harness - if correct voltage is present, replace EPS assembly - see Section 8).

CAUTION

Do not attempt to disassemble the EPS assembly as there are no serviceable components within the assembly and damage will occur voiding the EPS warranty.

Condition: Ignition switch ON and EPS assist normal when moving handlebar. Code "P0635" flashing.

1. Check for speed sensor signal by disconnecting the 8-pin connector from the EPS assembly and using a multi-meter set to the DC volt position, connect the black lead to the PNK/YEL wire and the red lead to the ORG wire. With the ignition switch turned to the ON position, slowly move the vehicle forward or backward. The meter must alternate from 0 DC volts to approximately 12 DC volts. If meter readings are not as specified:
 - A. Check EPS diode for correct installation or open diode (replace diode or install correctly).
 - B. Check speed sensor using procedure found in this section (replace speed sensor/install proper gauge).
2. Check for engine speed signal by disconnecting the 8-pin connector from the EPS assembly and using a multi-meter set to the AC voltage position, connect one lead to any BLK wire and the other lead to YEL/VLT wire. Start the engine and with the engine idling the meter should read approximately 7.5 AC volts. If meter reading is not as specified:
 - A. Check the wiring harness from EPS to gauge (YEL/VLT wire - repair wiring).
 - B. Check the AC generator using the procedure in this section. If not to specifications, replace the stator coil.

If after completing the above checks with normal results and malfunction code "P0635" persists, the EPS assembly must be replaced. To replace the EPS assembly, see Section 8.

Ignition Switch

To access the ignition switch, dash switches, front accessory connectors, and front switched accessory connector, the dash must be unfastened and slid to the rear.

VOLTAGE

1. Set the meter selector to the DC Voltage position.
2. Connect the red meter lead to the red wire; then connect the black meter lead to ground.
3. Meter must show battery voltage.

■NOTE: If the meter shows no battery voltage, troubleshoot the main 30 amp fuse, the battery, or the main wiring harness.

4. Connect the red meter lead to the red/black wire; then with the black lead grounded, turn the ignition switch to the ON position. The meter must show battery voltage.
5. Connect the red meter lead to the yellow/green wire; then with the black lead grounded, turn the ignition switch to the START position. The starter should engage and the meter must show battery voltage.

■NOTE: When the starter is engaged, battery voltage will be approximately 10.5 DC volts.

Headlight Switch

VOLTAGE

1. Connect the red meter lead to the gray wire; then connect the black meter lead to the black wire.
2. Turn the ignition switch to the ON position. The meter must show battery voltage.

■NOTE: If the meter does not show battery voltage, troubleshoot the LIGHTS fuse on the power distribution module, the ignition switch, or the main harness.

3. Connect the red meter lead to the yellow wire; then select the high beam position on the headlight switch. The meter must show battery voltage.
4. Connect the red meter lead to either of the two white wires; then select the low beam position on the headlight switch. The meter must show battery voltage.

■NOTE: The battery voltage will show lower in steps 3 and 4 due to electrical loading of the headlights.

Drive Select Switch

RESISTANCE

1. Remove the switch assembly from the dash; then disconnect the harness from the switch.

■NOTE: The switch can be removed from the dash using a thin, flat pry bar or suitable putty knife. It is not necessary to remove the dash to remove the switch.

2. Using an ohmmeter, the following readings must be observed.

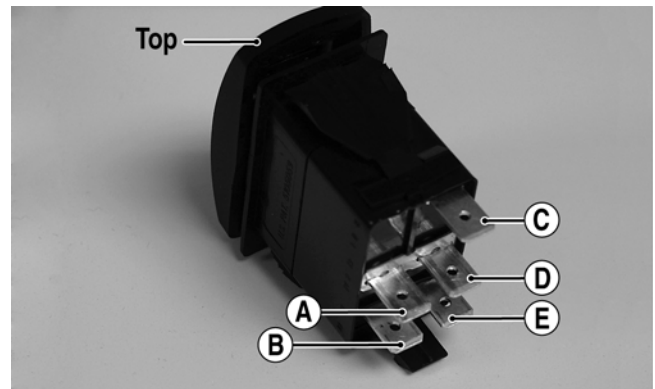

PR566A

2WD	4WD	DIFFERENTIAL LOCK
A to D <1 ohm	A to D <1 ohm	A to D <1 ohm
C to E <1 ohm	C to E <1 ohm	C to E <1 ohm
A to B Open	A to B <1 ohm	A to B <1 ohm
A to C Open	A to C Open	A to C <1 ohm
A to E Open	A to B <1 ohm	A to C <1 ohm

VOLTAGE

■NOTE: Voltage tests must be made with the switch and the actuator connected. The meter can be connected at the actuator connector using a break-out harness or MaxiClips.

1. Connect the black tester lead to the black wire; then turn the ignition switch to the ON position.
2. Select the DC Volts position on the tester and observe the meter readings for each of the three switch positions.

WIRE COLOR	2WD	4WD	DIFFERENTIAL LOCK
Black to Orange	12.0 DC Volts	12.0 DC Volts	12.0 DC Volts
Black to White/Green	11.5 DC Volts	0 DC Volts	0 DC Volts
Black to White/Red	11.5 DC Volts	11.5 DC Volts	0 DC Volts

■NOTE: If the meter does not show voltages according to the chart, make sure the front drive actuator is plugged in; then troubleshoot the switch, ignition fuses, battery connections, or wiring harness.

Reverse Override Switch

VOLTAGE

■NOTE: To perform the following tests, the ignition switch must be in the ON position and the transmission shifted into reverse gear.

1. Connect the red meter lead to the black/blue wire and the black meter lead to a suitable ground; then select 2WD on the drive select switch. The meter must show approximately 1.5 DC volts.
2. Depress the reverse override switch. The meter showing should not change from step 1.
3. Select 4WD on the drive select switch. The meter must show approximately 5 DC volts.
4. Depress the reverse override switch. The meter must show approximately 1.5 DC volts.
5. Connect the red meter lead to the red/yellow wire. The meter must show approximately 1.5 DC volts. Depress the reverse override switch. The meter must show approximately 1.5 DC volts.
6. Connect the red meter lead to the red/green wire. The meter should show 0 DC volts.
7. Depress the reverse override switch. The meter must show approximately 5 DC volts.

Front Drive Actuator

■NOTE: With the engine stopped and the ignition switch in the ON position, a momentary “whirring” sound must be noticeable each time the selector switch is moved to 2WD and 4WD. Test the switch, 30 amp fuse, and wiring connections prior to testing the actuator.

■NOTE: The differential must be in the unlocked position for this procedure.

VOLTAGE

1. Locate the 4-wire connector for the front drive selector actuator on the frame to the right of the differential; then connect the red meter lead to the orange wire using a MaxiClip.



PR293

2. Connect the black lead to the black wire using a Maxi-Clip; then select 2WD on the drive select switch.



PR295

■NOTE: The black tester lead can remain connected to the black wire for the remaining tests.

3. Turn the ignition switch to the ON position. The meter must show battery voltage.

■NOTE: If battery voltage is not shown, troubleshoot the 10 amp ignition (IGN) fuse on the power distribution module, the ignition switch, or the main wiring harness.

4. Connect the red meter lead to the white/red wire. The meter must show battery voltage.
5. Select 4WD on the drive select switch. The meter must show 0 DC volts.
6. Connect the red meter lead to the white/orange wire. The meter must show battery voltage.
7. Engage the differential lock. The meter must show 0 DC volts.

■NOTE: If the meter does not show 0 DC volts, rock the vehicle to help engage the differential lock; then troubleshoot the differential lock switch (see Drive Select Switch in this section).

Stator Coil/Crankshaft Position (CKP) Sensor

VOLTAGE (AC Generator - Regulated Output)

1. Set the meter selector to the DC Voltage position.
2. Connect the red tester lead to the positive battery post; then connect the black tester lead to the negative battery post.
3. With the engine running at a constant 5000 RPM (with the headlights on), the meter must show 14-15.5 DC volts.

CAUTION

Do not run the engine at high RPM for more than 10 seconds.

■NOTE: If voltage is lower than specified, test AC Generator - No Load.

VOLTAGE (AC Generator - No Load)

The connector is the black three-pin one on the left side above the shift lever.

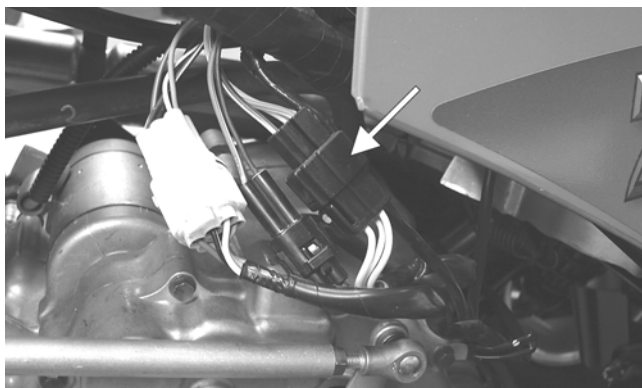

FI083B

■NOTE: Test the connector coming from the engine.

1. Set the meter selector to the AC Voltage position.
2. Test between the three yellow wires for a total of three tests.
3. With the engine running at a constant 5000 RPM, all wire tests must be within specification.

CAUTION

Do not run the engine at high RPM for more than 10 seconds.

■NOTE: If both stator coil tests failed, check all connections, etc., and test again. If no voltage is present, replace the stator assembly.

RESISTANCE (AC Generator)

CAUTION

Always disconnect the battery when performing resistance tests to avoid damaging the multimeter.

1. Set the meter selector to OHMS position.
2. Test between the three yellow wires for a total of three tests.
3. The meter reading must be within specification.

RESISTANCE (Crankshaft Position Sensor)

1. Set the meter selector to the OHMS position.
2. Connect the red tester lead to the blue wire; then connect the black tester lead to the green wire. The meter reading must be within specification.

AC VOLTAGE

■NOTE: The battery must be at full charge for these tests.

Crankshaft Position Sensor

1. Set the meter selector to the AC Voltage position.
2. Connect the red tester lead to the blue wire; then connect the black tester lead to the green wire.
3. Crank the engine over using the electric starter.
4. The meter reading must be within specification.

5

Starter Motor

■NOTE: The starter motor is not a serviceable component. If the motor is defective, it must be replaced.

REMOVING

1. Disconnect the battery.

CAUTION

Always disconnect the negative battery cable from the battery first; then disconnect the positive cable.

2. Remove the nut securing the positive cable to the starter; then remove the cable from the starter.
3. Remove the two cap screws securing the starter with ground wires to the crankcase; then remove the starter. Account for the wiring forms and an O-ring.

INSTALLING

1. Apply a small amount of grease to the O-ring seal on the starter; then install the starter into the crankcase. Secure with two machine screws and wiring forms.
2. Secure the positive cable to the starter with the nut.

3. Connect the battery.

TESTING VOLTAGE

Perform this test on the starter motor positive terminal. To access the terminal, slide the boot away.

■NOTE: The ignition switch must be in the ON position, and the shift lever in the NEUTRAL position.

1. Set the meter selector to the DC Voltage position.
2. Connect the red tester lead to the starter terminal; then connect the black tester lead to ground.
3. With the starter button depressed, the meter must show battery voltage and the starter motor should operate.



AR607D

■NOTE: If the meter showed battery voltage but the starter did not operate or operated slowly, inspect battery voltage (at the battery), starter motor condition, and/or ground connections.

■NOTE: If the meter showed no battery voltage, inspect the main fuse, ground connections, starter motor lead, battery voltage (at the battery), starter relay, or the neutral start relay.

Starter Relay

1. Remove the operator seat; then using the multimeter set to the DC Voltage position, check the relay as follows.
2. Connect the red tester lead to the positive battery terminal; then connect the black tester lead to the starter cable connection on the starter relay. The meter must show battery voltage.

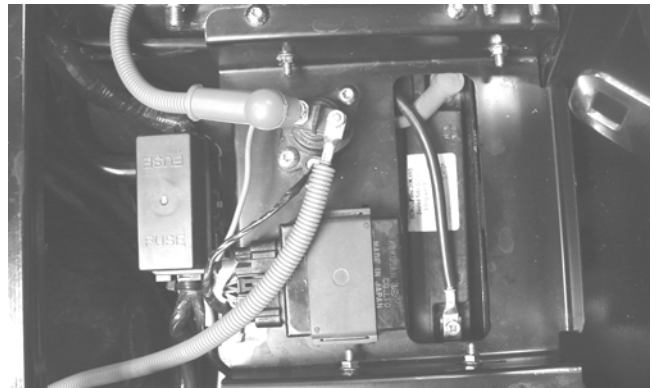

PR296

■NOTE: Make sure the ignition switch is in the ON position, transmission in neutral, and parking brake set.

3. Depress the starter button while observing the multimeter. The multimeter should drop to 0 volts and a “click” should be heard from the relay.

■NOTE: If a “click” is heard and more than one volt is indicated by the multimeter, replace the starter relay. If no “click” is heard and the multimeter continues to indicate battery voltage, proceed to step 4.

4. Disconnect the two-wire plug from the starter relay; then connect the red tester lead to the green wire and the black tester lead to the black wire.

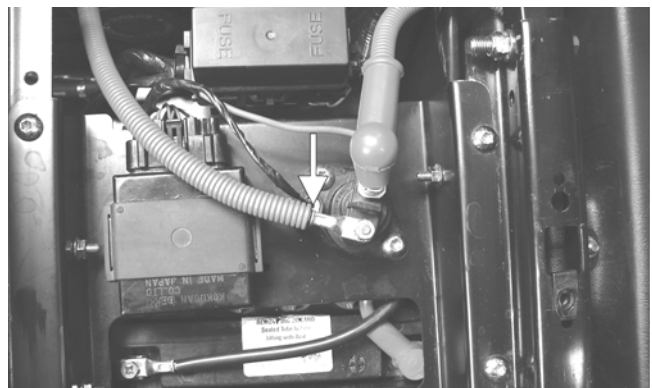

PR297A

5. Depress the starter button and observe the multimeter.

■NOTE: If battery voltage is indicated, replace the starter relay. If no voltage is indicated, proceed to Neutral Start Relay check.

Electronic Control Unit (ECU)

The ECU is located beneath the seat near the battery.

■NOTE: The ECU is not a serviceable component. If the unit is defective, it must be replaced.

The ECU is rarely the cause for electrical problems; however, if the ECU is suspected, substitute another ECU to verify the suspected one is defective.

This EFI system has a built-in feature that will only allow an ECU of the same part number to be used in this model. Do not attempt to substitute an ECU from a different model as the system will not allow it to start.

Error codes can be cleared by following the procedures located in the ECU Error Codes sub-section in this section.

Regulator/Rectifier

The regulator/rectifier is located under the seat next to the battery. Try to verify all other charging system components before the regulator/rectifier is replaced.

TESTING

1. Start engine and warm up to normal operating temperatures; then connect a multimeter (set at the DC Voltage position) to the battery as follows.
2. Connect the red tester lead to the positive battery post and the black tester lead to the negative battery post.
3. Slowly increase RPM. The voltage should increase with the engine RPM to a maximum of 15.5 DC volts.

■NOTE: If voltage rises above 15.5 DC volts, the regulator is faulty or a battery connection is loose or corroded. Clean and tighten battery connections or replace the regulator/rectifier. If voltage does not rise, check Voltage in this section. If charging coil voltage is normal, replace the regulator/rectifier.

Headlights

The connectors are the four 2-prong ones secured to the headlight bulbs (two on each side).

VOLTAGE

■NOTE: The low beams are the outside bulbs (black and white wires) and the high beams are the inside bulbs (yellow and black wires). Always connect the black tester lead to the black wires. The ignition switch must be in the ON position.

1. Set the meter selector to the DC Voltage position.
2. Set the light switch to the correct position for the affected light; then connect the black tester lead to the black wire using a MaxiClip.
3. Connect the red tester lead to the yellow wire (high beam) or white wire (low beam) using a MaxiClip. The meter must show battery voltage.

■NOTE: If battery voltage is not shown in any test, inspect the LIGHTS fuse on the power distribution module, headlight switch, ignition switch, switch connectors, or wiring harness.

Taillight-Brakelight

VOLTAGE (Taillight)

■NOTE: Perform this test at the socket end of the taillight-brakelight harness (pigtail). The ignition switch must be in the ON position and either high beam or low beam selected on the light switch.

1. Set the meter selector to the DC Voltage position.
2. Connect the black tester lead to the black wire; then connect the red tester lead to the white wire. The meter should show battery voltage.
3. With the ignition key in the LIGHTS position, the meter must show battery voltage.

■NOTE: If battery voltage is not shown and the headlights are illuminated, inspect the three-wire connector in the left-rear canopy tube at the juncture of the canopy tube and lower frame. If battery voltage is shown on the meter, replace the bulb.

VOLTAGE (Brakelight)

■NOTE: Perform this test at the socket end of the taillight/brakelight harness (pigtail). The ignition switch must be in the ON position.

1. Set the meter selector to the DC Voltage position.
2. Connect the red tester lead to the red/blue wire; then connect the black tester lead to the black wire.
3. With the brake applied, the meter must show battery voltage.

■NOTE: If the meter shows no voltage, inspect the 10 amp ignition (IGN) fuse, brakelight switch, wiring harness, or connectors.

Ignition Timing

The ignition timing cannot be adjusted; however, verifying ignition timing can aid in troubleshooting other components. To verify ignition timing, use the following procedure.

■NOTE: To check ignition timing, the seat, seat back, and seat base must be removed.

1. Attach the Timing Light to the spark plug high tension lead; then remove the timing inspection plug from the left-side crankcase cover.

2. Start the engine and using the RPM function on the speedometer/tachometer, run at 1500 RPM; ignition timing should be 10° BTDC.
3. Install the timing inspection plug.

If ignition timing cannot be verified, the rotor may be damaged, the key may be sheared, the trigger coil bracket may be bent or damaged, or the ECU may be faulty.

ECU Error Codes

If a sensor fails or an out-of-tolerance signal is sensed by the ECU, an error code will be generated by the ECU. This will result in the analog needle swinging full scale. The EFI icon will flash.

To read the error code(s), use the following procedure.

1. Make sure the ignition switch is in the OFF position; then remove the seats.
2. Locate the diagnostic plug next to the PDM; then remove the black rubber cap.
3. Connect the Test Plug from Test Plug/Error Code List to the diagnostic plug.

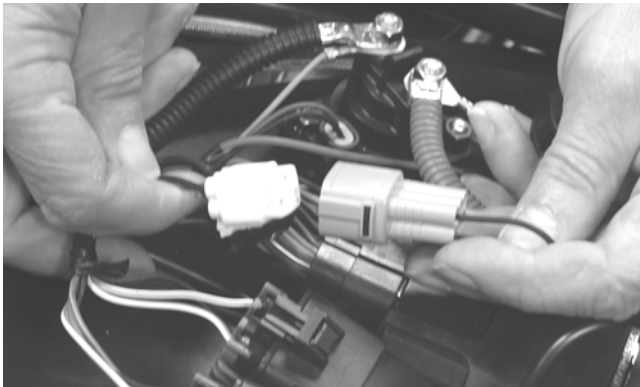

ATV-112

4. Turn the ignition switch to the ON position and read the error code on the LCD. Refer to the following ECU Error Code List to identify the specific problem area.

ECU Error Code List

NOTE: Each of the following numerical codes will have a two-letter prefix. A prefix of AC (Active Code) or SC (Stored Code) will be displayed. Always correct and clear Active Codes before clearing Stored Codes.

- 00 = No Fault Detected (active code only)
- 12 = CKP (Crankshaft Position) Sensor*
- 13 = APS (Air Pressure Sensor) - H1
- 13 = MAP (Manifold Absolute Pressure) Sensor - H2
- 14 = TPS (Throttle Position Sensor)
- 15 = ECT (Engine Coolant Temperature) Sensor
- 16 = Speed Sensor
- 21 = IAT (Inlet Air Temperature) Sensor
- 23 = Tilt Sensor*
- 24 = Ignition Coil #1*

- 26 = Ignition Coil #2* - H2
- 32 = Fuel Injector #1*
- 34 = Fuel Injector #2* - H2
- 40 = ISC (Idle Speed Control) Valve
- 41 = Fuel Pump Relay*
- 60 = Cooling Fan Relay
- 95 = Sensor Power
- 96 = Incorrect ECU*
- 97 = ECU Memory Power (constant battery power)
- 98 = ECU to Gauge Comm Link - H2
- 99 = Start/Run Not Possible (active code only)

*Will initiate code 99.

After all stored codes are cleared, clear the error code(s) using the following procedure.

NOTE: The ignition switch should be in the OFF position.

1. With the test plug connected to the diagnostic plug and the drive select switch in the 4WD position, hold the reverse override switch down and turn the ignition switch to the ON position.
2. After ten seconds, release the reverse override switch and turn the ignition switch to the OFF position; then turn the ignition switch to the ON position. The display should read AC00 (no fault detected).

NOTE: If the LCD still displays an error code, continue troubleshooting the appropriate component.

3. Disconnect the test plug; then install the black rubber cap.
4. Install the seats making sure they lock securely in place.

Tilt Sensor

WARNING

Incorrect installation of the tilt sensor could cause sudden loss of engine power which could result in loss of vehicle control resulting in injury or death.

CAUTION

Do not drop the tilt sensor as shock can damage the internal mechanism.

SUPPLY VOLTAGE

1. Disconnect the three-wire connector from the sensor; then select DC Voltage on the multimeter and connect the red tester lead to the orange wire (C) and the black tester lead to the black wire (A).

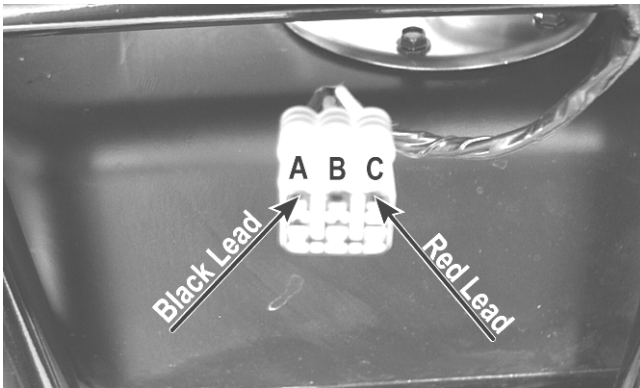

CD706A

2. Turn the ignition switch to the ON position. The multimeter should read battery voltage. If battery voltage is not indicated, check the 30-amp fuse, wiring harness, or the ignition switch.
3. Remove the red tester lead and connect to the blue/brown wire (B). The multimeter should read approximately 2.5 DC volts. If the specified voltage is not indicated, check wire connections at the ECU or substitute another ECU to verify the test.

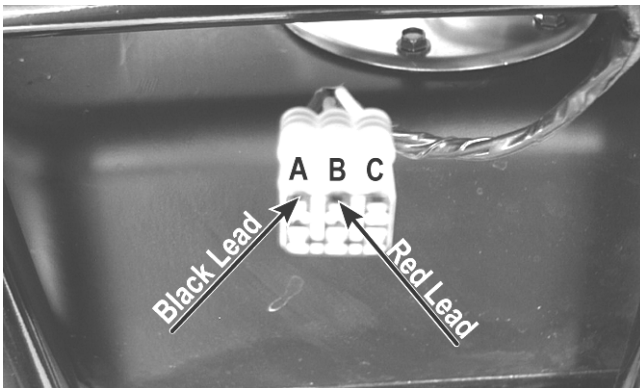

CD706B

OUTPUT VOLTAGE

■NOTE: Needle adapters will be required on the multimeter leads as the following tests are made with the sensor connected.

1. Connect the three-wire plug to the sensor; then remove the right-side mounting screw securing the sensor to the rear frame.



CD707

2. Install the needle adapters to the multimeter leads; then select DC Voltage on the multimeter.
3. Connect the red tester lead to the blue/brown wire (B) and the black tester lead to the black/yellow wire (A); then turn the ignition switch ON and observe the meter. The meter should read 0.8-3.0 DC volts.

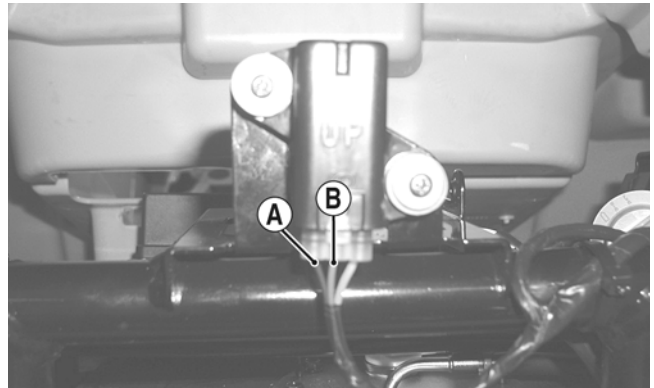

CD705B

4. Tilt the sensor 60° or more to the left and right observing the meter. The meter should read 4.0-8.0 DC volts after approximately one second in the tilted position. If the meter readings are not as specified, the tilt sensor is defective.

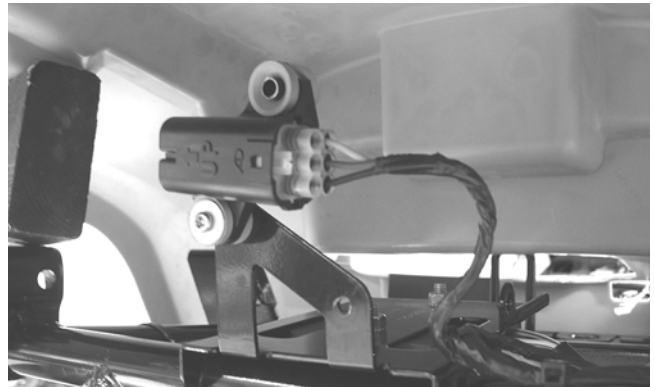

CD709

■NOTE: When replacing the sensor after testing, make sure the arrow marking is directed up.

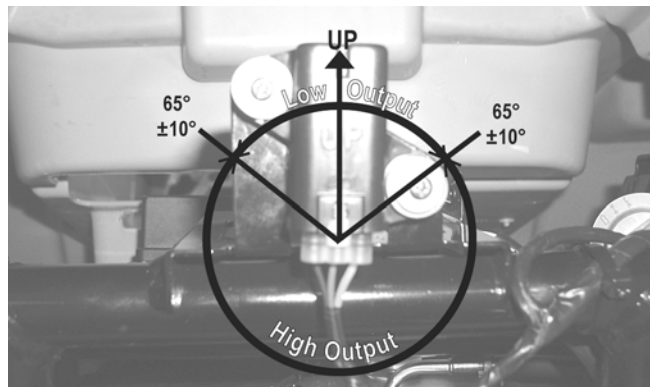

CD705A

Throttle Position Sensor (TPS)

INSPECTING

1. Remove the seat, seat base, and seat back; then disconnect the three-wire TPS connector plug.

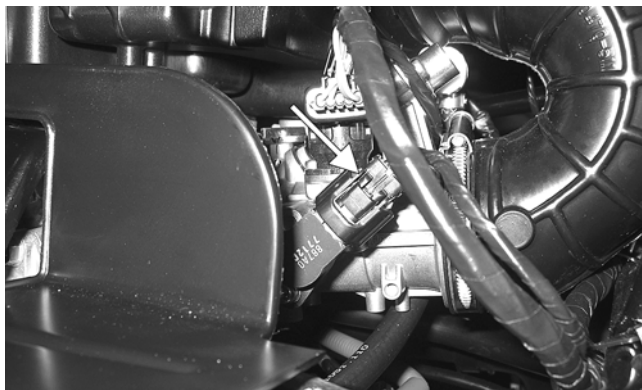

PR533A

■NOTE: Prior to testing the TPS, inspect the three-wire plug connector on the main harness and the three-pin plug on the TPS for contamination, broken pins, and/or corrosion.

2. Make sure the ignition switch is in the OFF position; then select the DC Voltage position on the meter.
3. Connect the black tester lead to terminal A and the red tester lead to terminal B. Turn the ignition switch to the ON position. The meter should read 4.5-5.5 DC volts.

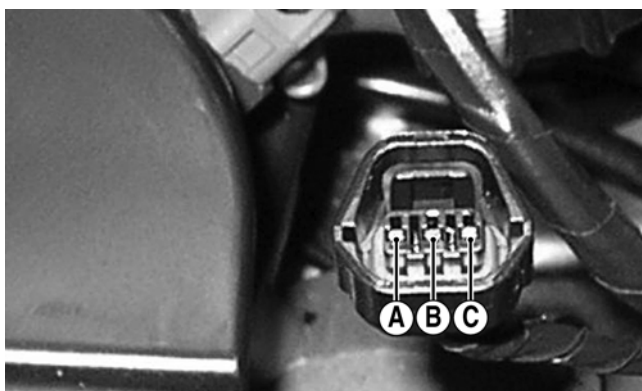

PR538A

4. Remove the black tester lead from terminal A and connect it to terminal C. The meter should read 5.0 DC volts.

■NOTE: If the meter does not read as specified, check for poor connections at the ECU or open/broken wires in the wiring harness.

CAUTION

Always make sure the ignition switch is in the OFF position before disconnecting the ECU.

5. Turn the ignition switch to the OFF position.
6. Select the OHMS position on the meter; then perform the following resistance tests on the TPS.

Throttle Position	Pins	Ohms
Closed	A, B, or C to Ground	Infinity (Open)
	A to B	5.0k
	A to C	650
Full-Open	B to C	4.5k
	A, B, or C to Ground	Infinity (Open)
	A to C	3.8k
	B to C	1.3k

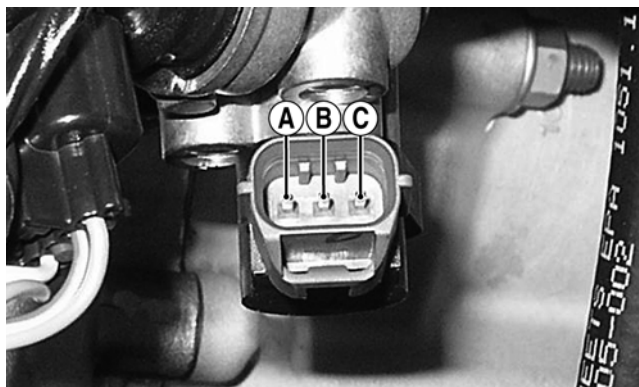

PR535A

■NOTE: If any meter reading is not as specified, replace or adjust the TPS (see INSTALLING/ADJUSTING in this sub-section).

7. Connect the main harness TPS connector to the TPS; then using MaxiClips, connect the black tester lead to the black wire and the red tester lead to the green/black wire.

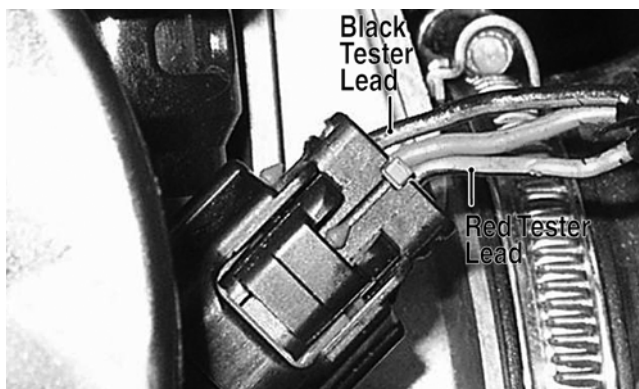

PR546A

8. Select the DC Voltage position on the meter and turn the ignition switch to the ON position. The meter should read approximately 0.6 DC volts with the throttle closed and approximately 5.0 DC volts with the throttle in the full-open position.

■NOTE: If the meter readings are as specified, check the main harness connector at the ECU main harness wiring. If the meter readings are not as specified, replace the TPS and adjust to specifications (see INSTALLING/ADJUSTING in this sub-section).

CAUTION

Always make sure the ignition switch is in the OFF position before disconnecting the ECU.

9. Clear all ECU error codes after servicing is complete (see ECU Error Codes in this section).

REMOVING

1. Remove the seats and center console; then disconnect the three-wire TPS connector plug.

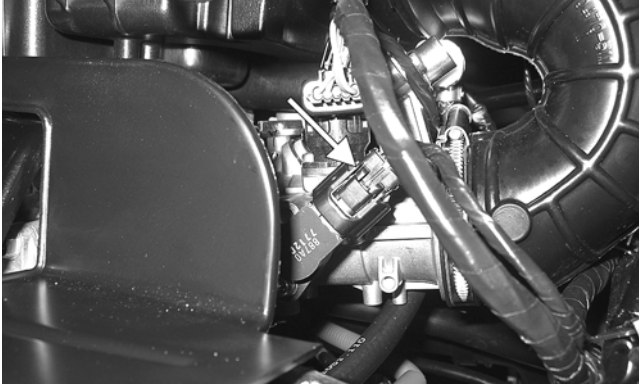

PR533A

2. Remove the screw securing the TPS to the throttle body and remove the TPS.

INSTALLING/ADJUSTING

1. Place the TPS into position on the throttle body and secure with the screw. Do not tighten at this time.
2. Connect the main harness to the TPS.
3. Locate the diagnostic plug under the seat next to the PDM; then install the Test Plug from Test Plug/Error Code List onto the plug.
4. Turn the ignition switch to the ON position and note the position of the TPS indicator icon (A, B, or C); then adjust the TPS until the TPS icon appears in the center position (B).



PR542A



PR540A



PR541A

5. Tighten the mounting screws securely; then verify the TPS icon appears in the center position.
6. Cycle the accelerator pedal to approximately half throttle six times; then return the accelerator pedal to idle. The display should return to the center position (B).
7. Remove the test plug; then install the seat base, seat back, and seat.

Troubleshooting

Problem: Spark absent or weak	
Condition	Remedy
<ol style="list-style-type: none"> 1. Ignition coil defective 2. Spark plug defective 3. CKP sensor defective 4. ECU defective 	<ol style="list-style-type: none"> 1. Replace ignition coil 2. Replace plug 3. Replace CKP sensor 4. Replace ECU
Problem: Spark plug fouled with carbon	
Condition	Remedy
<ol style="list-style-type: none"> 1. Gasoline incorrect 2. Air cleaner element dirty 3. Spark plug incorrect (too cold) 4. Valve seals cracked - missing 5. Oil rings worn - broken 	<ol style="list-style-type: none"> 1. Change to correct gasoline 2. Clean element 3. Replace plug 4. Replace seals 5. Replace rings
Problem: Spark plug electrodes overheat or burn	
Condition	Remedy
<ol style="list-style-type: none"> 1. Spark plug incorrect (too hot) 2. Engine overheats 3. Spark plug loose 	<ol style="list-style-type: none"> 1. Replace plug 2. Service cooling system 3. Tighten plug
Problem: Battery does not charge	
Condition	Remedy
<ol style="list-style-type: none"> 1. Lead wires/connections shorted - loose - open 2. Stator coils shorted - grounded - open 3. Regulator/rectifier shorted - punctured 	<ol style="list-style-type: none"> 1. Repair - replace - tighten lead wires 2. Replace stator coils 3. Replace regulator/rectifier
Problem: Battery charges, but charging rate is below the specification	
Condition	Remedy
<ol style="list-style-type: none"> 1. Lead wires shorted - open - loose (at terminals) 2. Stator coils grounded - open 3. Regulator/rectifier defective 4. Electrolyte low 5. Cell plates (battery) defective 	<ol style="list-style-type: none"> 1. Repair - tighten lead wires 2. Replace stator coils 3. Replace regulator/rectifier 4. Add distilled water 5. Replace battery
Problem: Magneto overcharges	
Condition	Remedy
<ol style="list-style-type: none"> 1. Internal battery short circuited 2. Regulator/rectifier resistor damaged - defective 3. Regulator/rectifier poorly grounded 	<ol style="list-style-type: none"> 1. Replace battery 2. Replace resistor 3. Clean - tighten ground connection
Problem: Charging unstable	
Condition	Remedy
<ol style="list-style-type: none"> 1. Lead wire intermittently shorting 2. Magneto internally shorted 3. Regulator/rectifier defective 	<ol style="list-style-type: none"> 1. Replace lead wire 2. Replace magneto 3. Replace regulator/rectifier

Problem: Starter does not engage	
Condition	Remedy
1. Battery charge low 2. Switch contacts defective 3. Starter motor brushes not seating 4. Starter relay defective 5. Emergency stop - ignition switch off 6. Wiring connections loose - disconnected	1. Recharge - replace battery 2. Replace switch 3. Replace starter 4. Replace relay 5. Turn on switches 6. Connect - tighten - repair connections
Problem: Battery "sulfation" (Acidic white powdery substance or spots on surfaces of cell plates)	
Condition	Remedy
1. Charging rate too low - too high 2. Battery electrolyte excessive - insufficient 3. Specific gravity too high - too low 4. Battery run-down - damaged 5. Electrolyte contaminated	1. Replace battery 2. Keep electrolyte to prescribed level 3. Charge battery - add distilled water 4. Replace battery 5. Replace battery
Problem: Battery discharges too rapidly	
Condition	Remedy
1. Electrolyte contaminated 2. Specific gravity too high 3. Charging system (charging operation) not set properly 4. Cell plates overcharged - damaged 5. Battery short-circuited 6. Specific gravity too low	1. Replace battery 2. Charge battery - add distilled water 3. Check AC generator - regulator/rectifier - circuit connections 4. Replace battery - correct charging system 5. Replace battery 6. Recharge battery
Problem: Battery polarity reversed	
Condition	Remedy
1. Battery incorrectly connected	1. Reverse connections - replace battery

NOTES

SECTION 6 - DRIVE SYSTEM

TABLE OF CONTENTS

Drive System	6-2
Front Drive Actuator	6-2
Front Differential	6-3
Drive Axles	6-15
Rear Gear Case	6-20
Hub	6-22
Hydraulic Brake Caliper	6-24
Universal Joints	6-28
Troubleshooting	6-30

Drive System

■NOTE: Some photographs and illustrations used in this section are used for clarity purposes only and are not designed to depict actual conditions.

■NOTE: Critical torque specifications are located in Section 1.

GENERAL INFORMATION

All gear cases are tagged beneath a cover bolt. This tag is marked with a production date code, sequence code, and a ratio code. All gear cases are 4.0:1 ratio.

The die-cast aluminum housings have been assembled with thread-rolling screws (trilobular). When assembling with these screws, start the screws carefully into the housing; then use the following torque values.

Size	New Housing	Reassembled Housing
M6 (Torx T-30 Recess)	9 ft-lb	8 ft-lb
M8 (Torx T-40 Recess)	28 ft-lb	23 ft-lb

■NOTE: Never reuse a lock nut. Once a lock nut has been removed, it must be replaced with a new lock nut.

SPECIAL TOOLS

A number of special tools must be available to the technician when performing service procedures in this section. Refer to the current Special Tools Catalog for the appropriate tool description.

Description	p/n
Backlash Measuring Tool (24-Spline Axle)	0544-010
Backlash Measuring Tool (27-Spline Axle)	0544-011
CV Boot Clamp Tool	0444-120
Internal Hex Socket	0444-104
Pinion Gear/Shaft Removal Tool	0444-127
Gear Case Seal Installer Tool	0444-224
U-Joint Separator Tool	0444-128

■NOTE: Special tools are available from the Arctic Cat Service Parts Department.

Front Drive Actuator

■NOTE: The actuator is not a serviceable component. If it is defective, it must be replaced.

■NOTE: The actuator will operate only when the ignition switch is in the ON position.

The front drive actuator is located on the right side of the front drive input housing. With the engine stopped and the ignition switch in the ON position, a momentary “whirring” sound can be heard each time the front drive selector switch is shifted. If no sound is heard, see Section 5. If the actuator runs constantly or makes squealing or grinding sounds, the actuator must be replaced.

REMOVING

1. Select LOCK on the drive select switch; then disconnect the connector on the actuator harness.
2. Using a T-30 torx wrench, remove the mounting cap screw from the driveshaft side of the actuator.

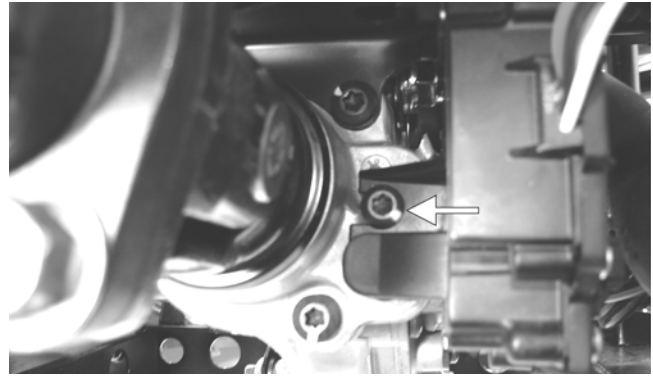

PR189A

3. Remove the mounting cap screw from above the actuator on the suspension side.

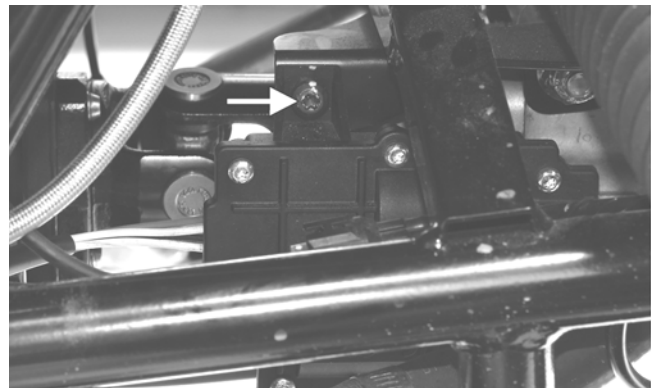

PR190A

4. Loosen but do not remove the mounting cap screw at the front of the actuator; then slide the actuator to the rear enough to clear the slotted mounting tab and the selector shaft. Remove from the right side.

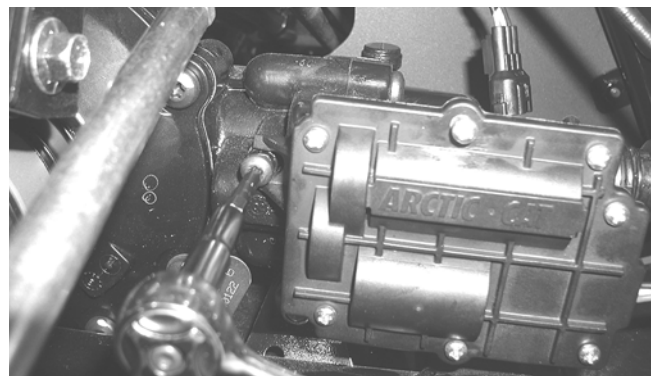

AG928

INSTALLING

1. Lubricate the O-rings on the actuator; then ensure all mounting surfaces are clean and free of debris.
2. Align the actuator with the selector shaft and slide it forward onto the shaft taking care to engage the cap screw in the slot of the front mounting tab.

■NOTE: Make sure to properly align the differential lock actuator lever with the hole in the differential lock plunger.

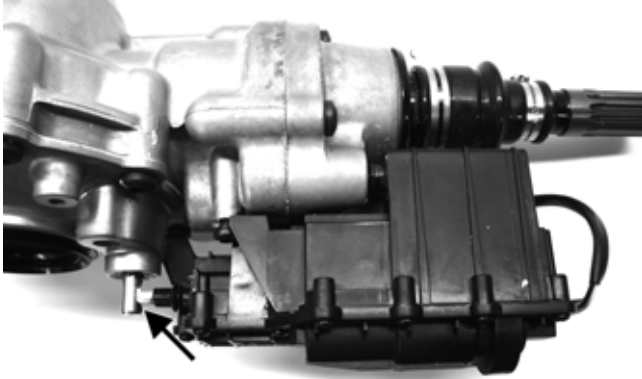

GC002A

3. While holding the actuator firmly forward, tighten the front cap screw to hold the actuator in place; then install but do not tighten the two remaining cap screws.

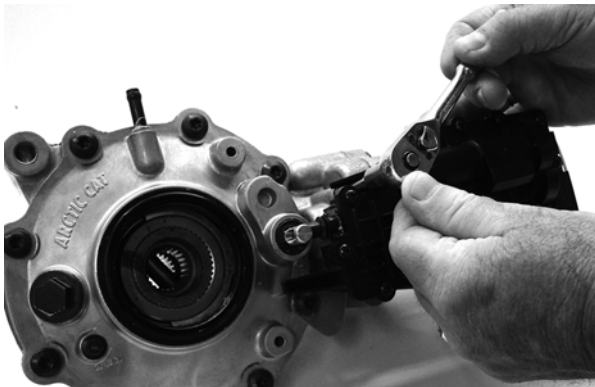

GC001

4. Loosen the front cap screw; then tighten the cap screw on the driveshaft side.



AG926

■NOTE: It is important to tighten this cap screw while the others are loose to ensure proper seating of the actuator.

5. Tighten the remaining cap screws; then connect the electrical plug to the main harness.
6. Turn the ignition switch to the ON position and check the operation by shifting the selector switch several times.
7. Secure the wiring harness to the frame with a nylon cable tie; then install the inner fender panel.

Front Differential

REMOVING

1. Remove the belly panel; then place the vehicle on jack stands adjusted high enough to allow working from the underside of the vehicle.

■NOTE: The jack stands should be placed under the main frame to avoid contact with front suspension components.

⚠ WARNING

Make sure the vehicle is solidly supported on the jack stands to avoid injury.

2. Remove the drain plug and drain the gear lubricant into a drain pan; then install the plug and tighten to 45 in.-lb.

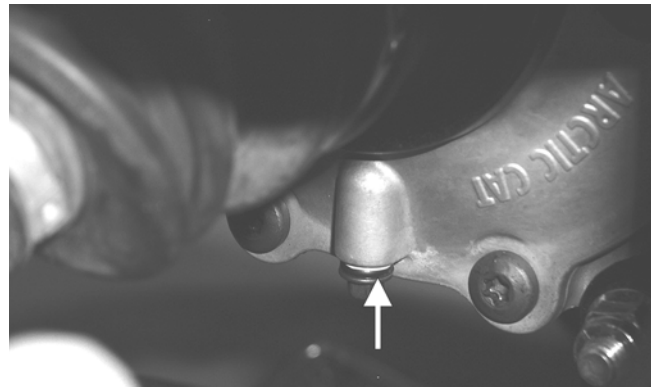

PR022A

3. Remove the front wheels.
4. Place the transmission in park; then turn the ignition switch to the ON position and select LOCK on the drive select switch.
5. Remove the cotter pin securing the axle nut; then remove the nut.

■NOTE: It is not necessary to remove the brake hoses from the calipers for this procedure.

6. Remove the two brake calipers. Account for the four cap screws; then remove the hubs.

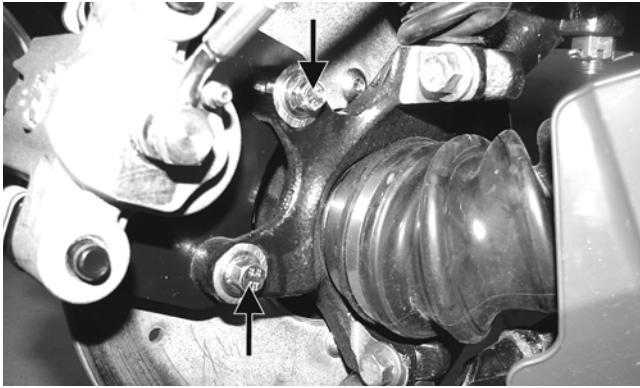

PR264A

7. Disconnect the front drive actuator connector from the main harness.

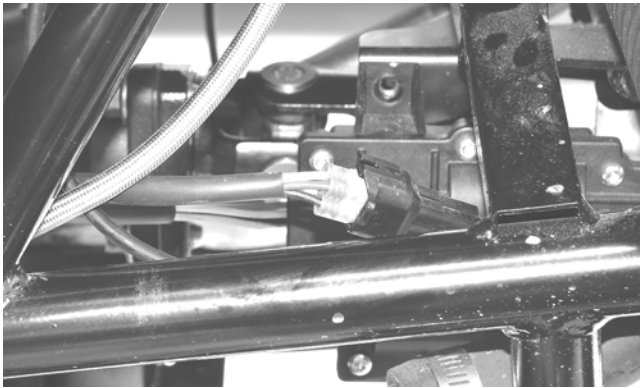

PR191

8. Remove the lower and upper ball joint cap screws taking care not to strip the threads on the ball joint shaft; then using a rubber mallet, tap the end of the axle and free it from the knuckle assembly.

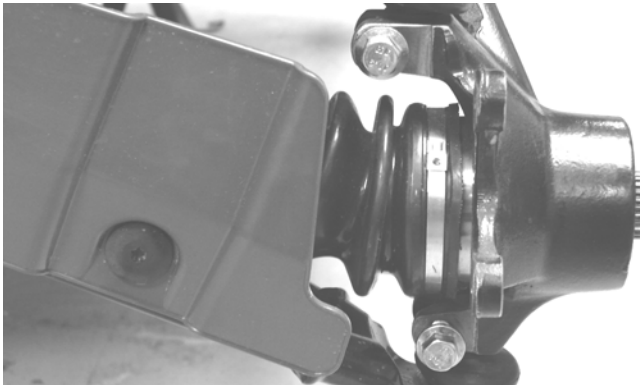

PR193

9. Pull the steering knuckle away from the axle.



PR222

10. Support the axle to not allow it to drop or hang.

CAUTION

The axle must be supported. If the axle is allowed to drop or hang, damage to the inner CV joint may occur.

11. Remove the lower shock cap screws. Account for the lock nuts; then move the shocks and upper A-arm up and secure them with a strap.

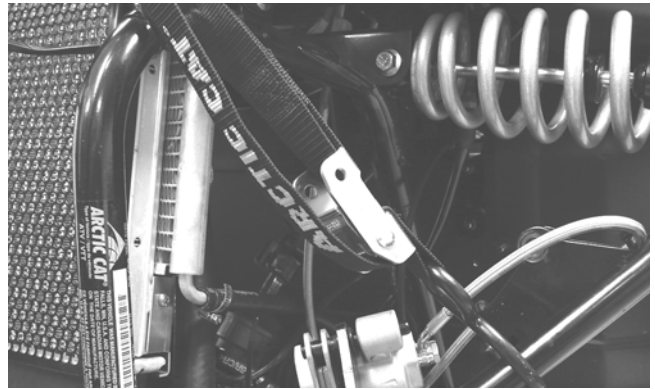

PR200

12. Push the axle shaft toward the differential to release the “plunge” coupler; then remove the axle from the differential. Repeat for the opposite side.

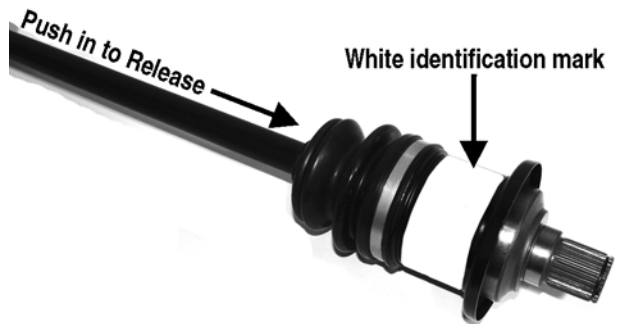

PR729B

13. Remove the lower differential mounting cap screw. Account for a lock nut and four washers. Note the position of the washers for assembling.

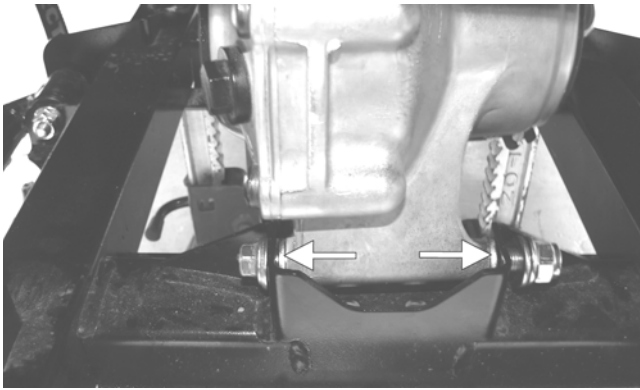

PR205A

14. Remove the upper differential mounting cap screw. Account for a lock nut and two washers.



CD016

15. Free the differential assembly from the frame mountings; then lower the differential through the frame.

Disassembling Input Shaft

■NOTE: This procedure can be performed on a rear gear case.

1. Using a T-40 torx wrench, remove the cap screws securing the pinion housing.



GC004A

2. Using a rubber mallet, remove the housing. Account for a gasket. Remove the fork, collar, and spring. Note the location of all the components for assembling purposes.



GC015

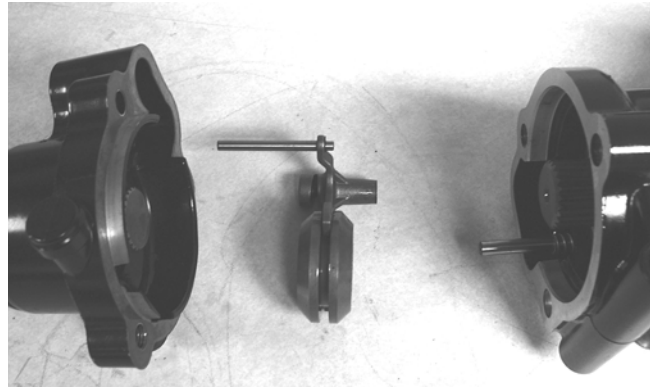

CD106

3. Remove the snap rings from the input shaft; then remove the input shaft from the pinion housing.



GC009A

4. Using a seal removal tool, remove the input shaft seal. Account for a spacer.



GC010

- Remove the snap ring securing the input shaft bearing; then place the pinion housing in a press and remove the bearing.



GC011



GC012

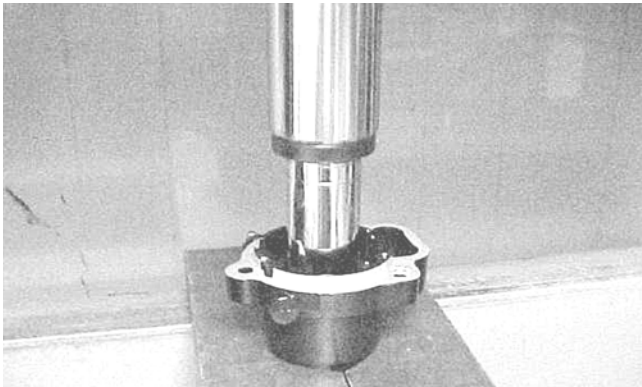

AF984



GC011

- Install the input shaft seal making sure it is fully seated in the edge of the housing.

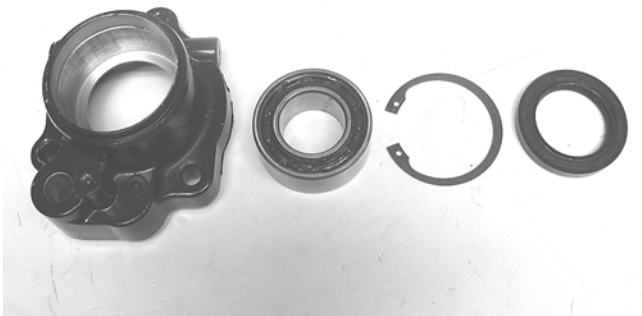

KX219

Assembling Input Shaft

- Place the pinion housing in a press and install the input shaft bearing. Secure the bearing with the existing snap ring making sure the sharp edge of the snap ring faces to the outside.

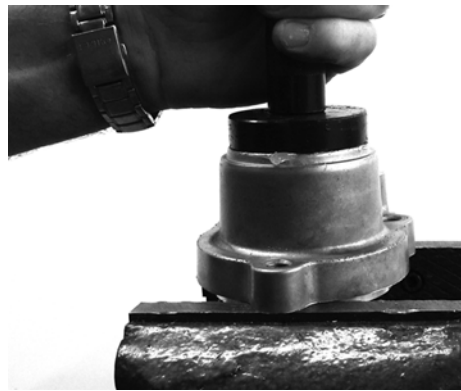

GC014

- Lubricate the input shaft with High-Performance #2 Molybdenum Disulphide Grease packing the boot ribs and splines; then assemble allowing excess grease to freely escape. Slight pressure on the boot will be present during assembly. Secure with new clamps.

■ **NOTE:** Any time drive splines are separated, clean all splines with parts-cleaning solvent and dry with compressed air; then lubricate with recommended grease.

- Install the input shaft into the pinion housing; then secure in the bearing with a circlip.



GC009A

5. Place the pinion housing with new gasket onto the differential housing; then secure with existing cap screws. Tighten to 23 ft-lb.

■NOTE: If a new differential housing is being installed, tighten the cap screws to 28 ft-lb.



GC015

2. Using a T-40 torx wrench, remove the cap screws securing the differential cover. Account for and make note of the ID tag location for assembling purposes.

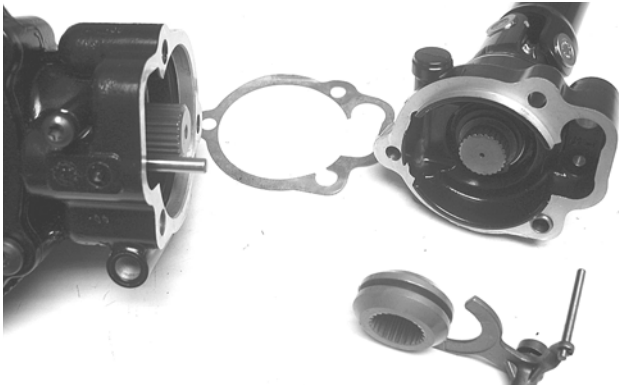

KX209



GC003

3. Using a plastic mallet, tap lightly to remove the differential cover. Account for an O-ring.



GZ004A

Disassembling Differential Assembly

■NOTE: This procedure can be performed on a rear gear case.

1. Using a T-40 torx wrench, remove the cap screws securing the pinion housing. Account for the coupler, fork, and spring (differential only).



KX174

■NOTE: If the cover is difficult to remove, pry on the cover in more than one recessed location.

4. Remove the splined coupler, shifter fork, pin, and spring of the differential lock assembly and set aside. Note position of parts for assembling purposes.

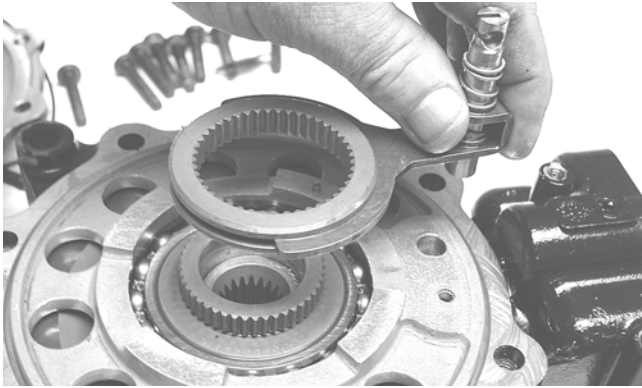

KX175

5. Remove the left differential bearing flange assembly and account for a shim. Mark the shim as left-side.



KX177

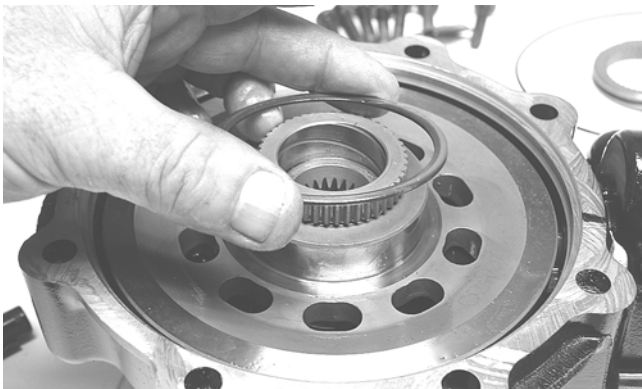

KX178

6. Place the differential with the open side down; then lift the housing off the spider assembly. Account for shim(s) and mark as right-side.



KX179

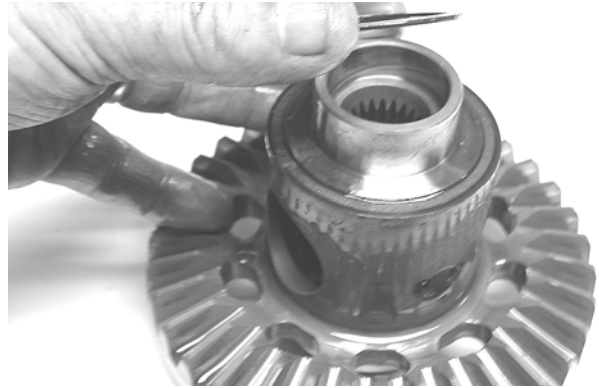

KX181

Disassembling Pinion Gear

■NOTE: Any service of the pinion gear or related bearings will require a new gear case/differential housing. The removal of the lock collar severely damages the threads in the housing.

1. Using the 48 mm Internal Hex Socket, remove the lock collar securing the pinion gear assembly.

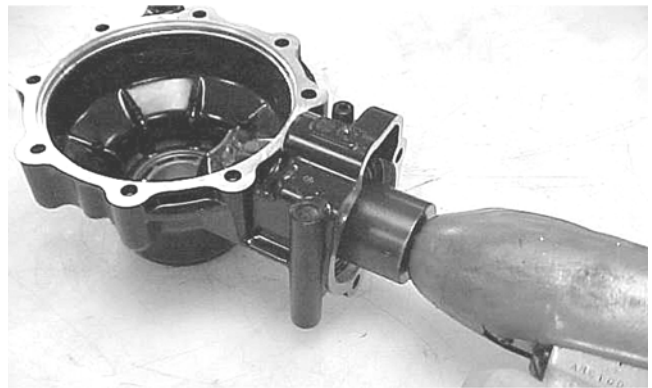

CC875



CC876

2. Using the Pinion Gear/Shaft Removal Tool and a hammer, remove the pinion gear from the gear case housing.

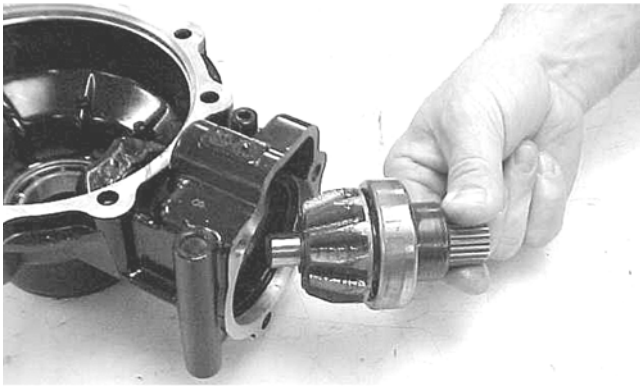

CC878

3. Secure the pinion gear in a bearing puller; then remove the pinion bearing using a press. Account for a collar and a bearing.

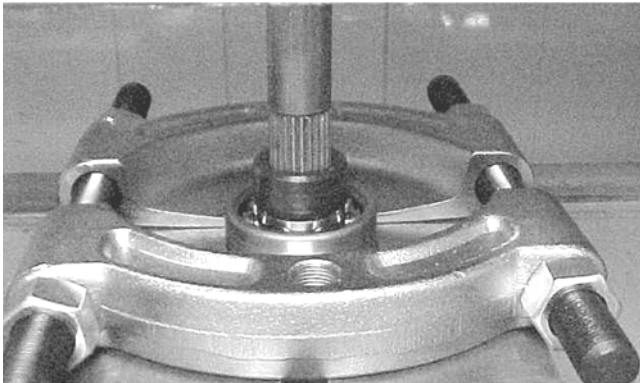

CC879

4. Remove any reusable parts from the gear case housing; then discard the housing and lock collar.

Assembling Pinion Gear

1. Install the bearing onto the pinion shaft. Install the pinion shaft collar.

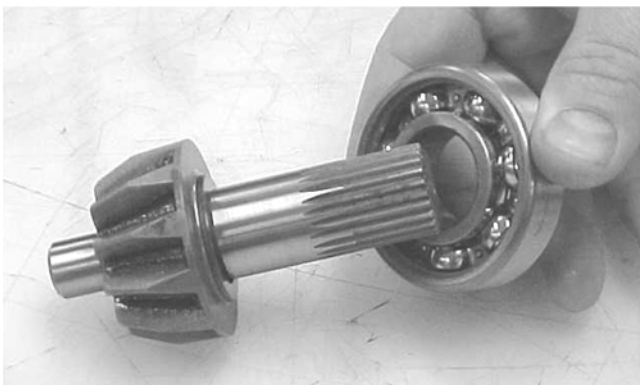

CC882

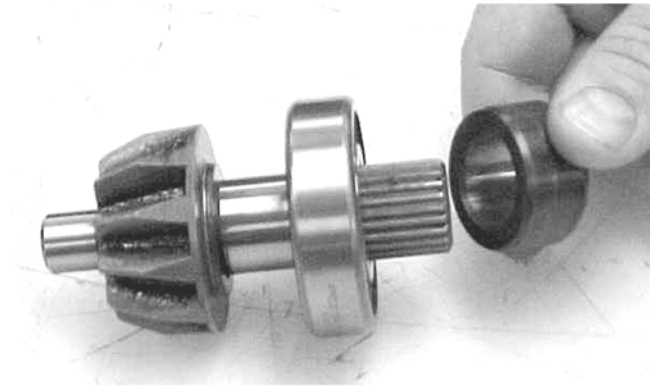

CC883

2. Place the pinion assembly in a bearing puller; then install the bearing using a press.

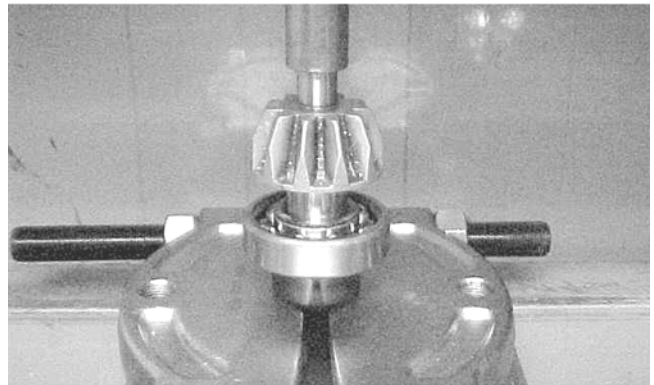

CC884

3. Coat a new needle bearing and the bearing pocket of a new gear case/differential housing with red Loctite #271; then using a suitable driver, install the bearing lightly seated against the bearing seats. Do not push the bearing too far into the pocket.

6



GC044

4. Install the pinion gear assembly into the housing. Using the 48 mm Internal Hex Socket, secure the pinion gear assembly with the existing lock collar. Tighten to 125 ft-lb.

■ **NOTE:** On a front differential, the lock collar has right-hand threads. On a rear drive gear case, the lock collar has left-hand threads or a snap-ring.

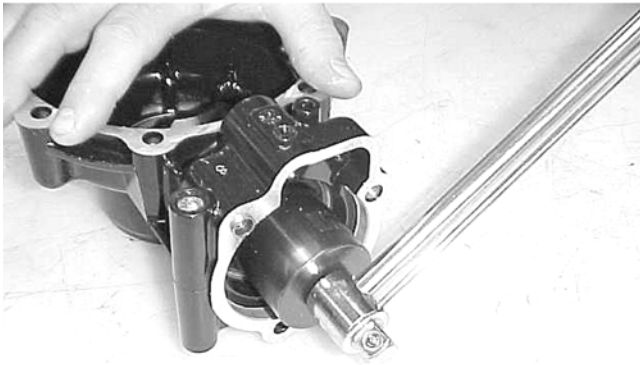

CC890

- Place a punch on the edge of the lock collar in the oil gallery area; then using a hammer, stake the lock collar to ensure that the collar will remain securely tightened.

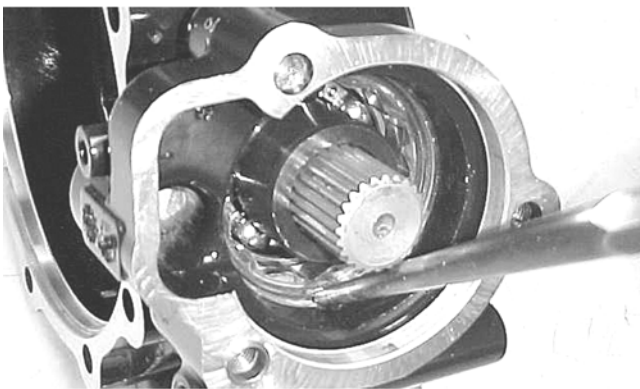

CC891

Shimming Procedure/Shim Selection

Case-side Shims (Backlash)		
p/n	mm	in.
0402-405	1.3	0.051
0402-406	1.4	0.055
0402-407	1.5	0.059
0402-408	1.6	0.063
0402-409	1.7	0.067

Cover-side Shims (Ring Gear End-Play)		
p/n	mm	in.
1402-074	1.3	0.051
1402-075	1.4	0.055
1402-076	1.5	0.059
1402-077	1.6	0.063
1402-078	1.7	0.067

It is very important to adjust bevel gears for the proper running tolerances. Gear life and gear noise are greatly affected by these tolerances; therefore, it is very important to properly adjust any gear set prior to final assembly.

The following procedure can be used on both front differential or rear drive gear case.

■NOTE: All bearings must be installed in the gear case and the pinion properly installed before proceeding.

Backlash

■NOTE: Always set backlash prior to any other shimming.

- Install the existing shim or a 0.051-0.055-in. shim on the gear case side of the ring gear assembly.



GC031A

- Install the ring gear with shim in the gear case; then while holding the pinion stationary, rock the ring gear forward and back to determine if any backlash exists. If no backlash exists, install a thicker shim and recheck.



GC036A

- Install the bearing flange onto the gear case cover making sure the alignment/locating pin engages the locating hole in the cover; then make sure the bearing flange is completely seated in the cover.

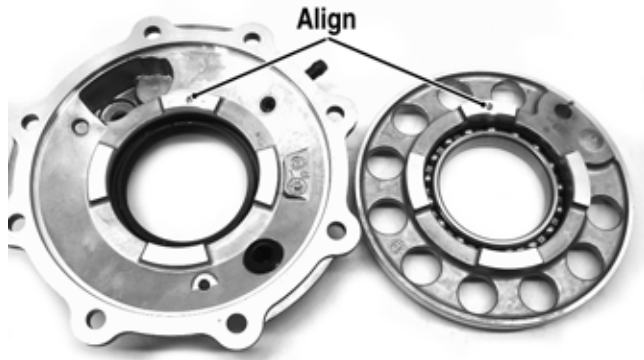

GC032A



GC040



GC033A

4. Install the existing shim or a 0.063 in. shim on the cover side of the ring gear; then place the assembled gear case cover onto the gear case and secure with three cap screws. Tighten evenly using a crisscross pattern.



GC039A

6. Zero the dial indicator; then while holding the pinion stationary, rock the ring gear assembly forward and back and record the backlash. Backlash must be .011-.015 in. If backlash is within specifications, proceed to Ring Gear End-Play. If backlash is not within specifications, increase shim thickness to increase backlash or decrease shim thickness to decrease backlash.

■NOTE: Higher backlash settings usually result in quieter gear operation.

6



GC036B

5. Place the appropriate Backlash Measuring Tool into the splines of the ring gear and install a dial indicator making sure it contacts the gauge at a 90° angle and on the index mark.

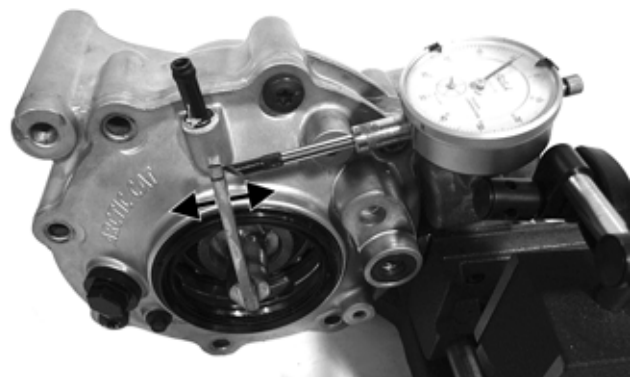

GC037A

Ring Gear End-Play

After correcting backlash, ring gear end-play can be adjusted. To adjust end-play, use the following procedure.

1. Secure the gear case in a holding fixture with the cover side up; then install a dial indicator contacting the ring gear axle flange.

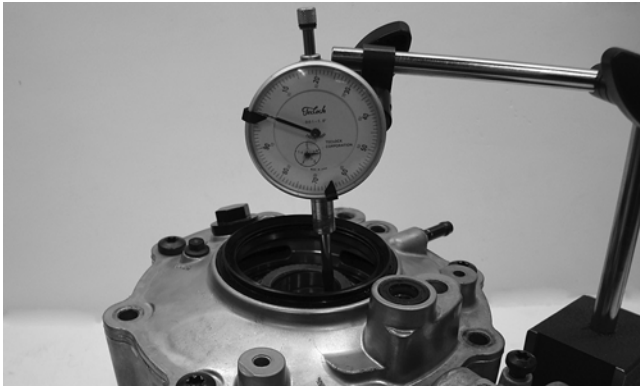

GC035

2. Zero the dial indicator; then push the ring gear toward the dial indicator and release. End-play should be 0.004-0.008 in.
3. To increase end-play, decrease the shim thickness. To decrease end-play, increase the shim thickness.

■NOTE: Once proper backlash and end play are established, the gear case can be assembled (see Assembling Differential Assembly in this sub-section).

Assembling Differential Assembly

1. With the pinion gear and new bearings installed, place the selected (backlash) shim on the gear case side of the ring gear with the chamfered side toward the ring gear; then install into gear case/differential housing.



GC031A



GC020

2. Place the selected (end-play) shim, chamfered side toward the gear, onto the cover side of the ring gear.

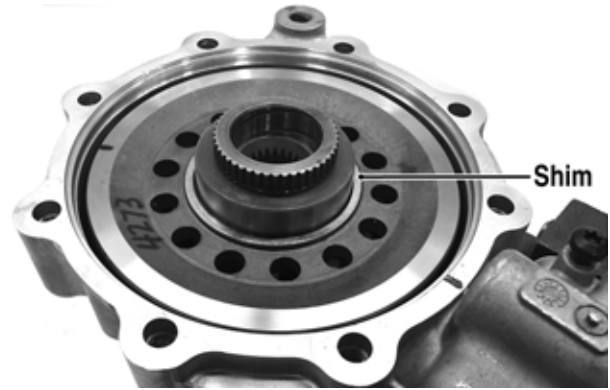

GC036B

■NOTE: The spider and ring gear assembly must be replaced as a complete unit.

3. Assemble the fork and sliding collar into the cover assembly; then install the left bearing flange/bearing assembly and seat firmly into the cover.

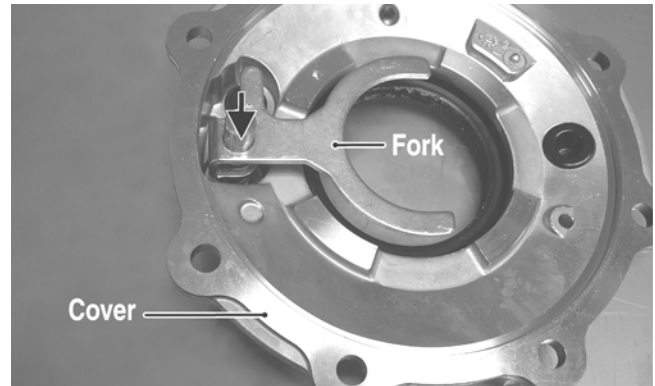

CF266A

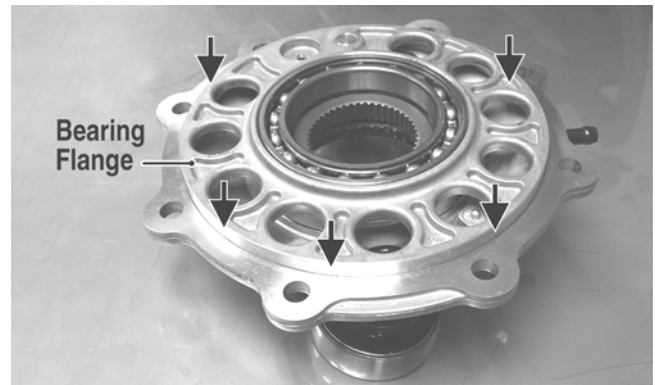

CF267A

4. Apply a liberal coat of grease to the O-ring; then install it on the assembled cover assembly making sure to seat the O-ring completely down around the circumference of the bearing flange.



CF275A

5. Making sure the O-ring is properly positioned on the differential housing cover assembly, install the cover with existing cap screws (coated with green Loctite #270). Account for the ID tag. Tighten the cap screws evenly to 23 ft-lb.

■NOTE: Grease can be applied to the O-ring for ease of assembling.

■NOTE: If a new housing is being installed, tighten the cap screws to 28 ft-lb.

6. Install the shift fork shaft w/spring into the housing making sure the shaft O-ring is positioned to the inside.

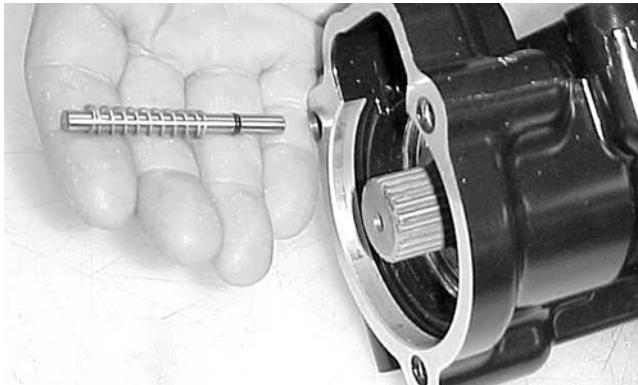

CC892

7. Install the shift fork assembly making sure the fork leg is facing upward. Apply a small amount of oil to the gasket; then install the gasket.

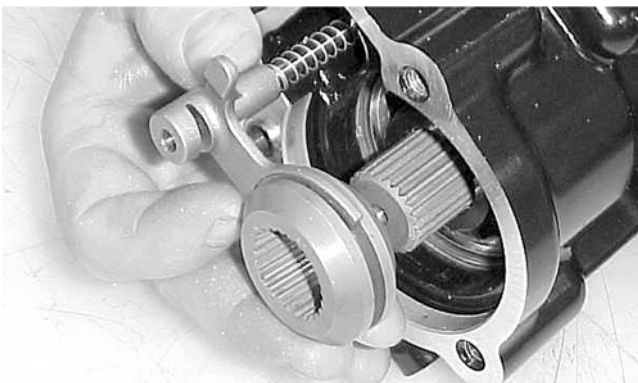

CC893

8. Place the input shaft assembly onto the gear case housing; then secure with the existing cap screws. Tighten to 23 ft-lb.

■NOTE: If a new housing is being installed, tighten the cap screws to 28 ft-lb.

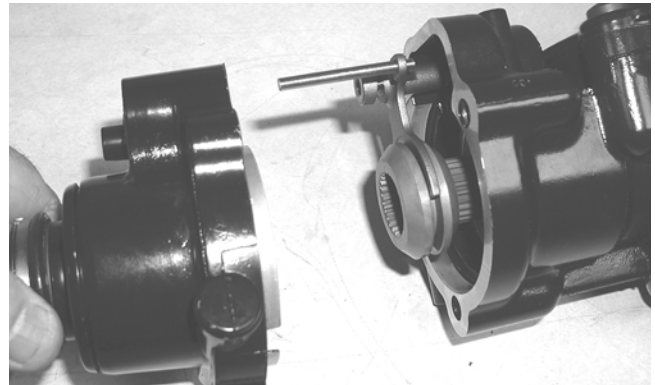

CD103

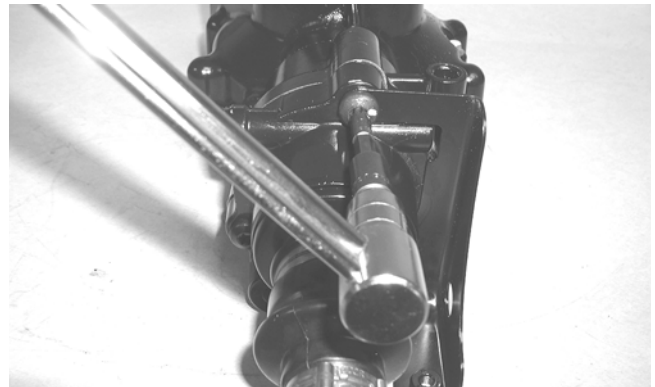

CD110

Removing/Installing Axle Seal

■NOTE: This procedure can be performed on a rear gear case.

1. Remove the seal using a seal removal tool.

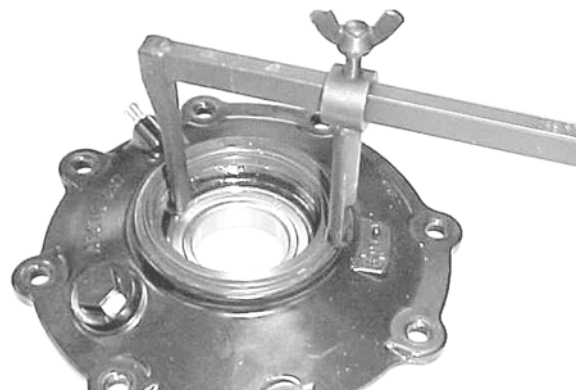

CC899

■NOTE: Prior to installing the seal, apply High-Performance #2 Molybdenum Disulphide grease to the seal outside diameter.

2. Using Gear Case Seal Installer Tool, evenly press the seal into the cover bore until properly seated.

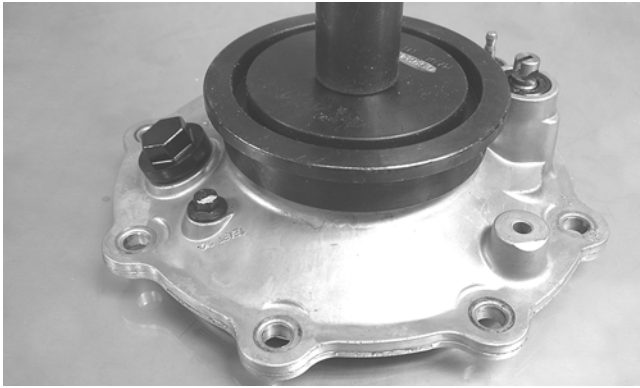

CF278

CAUTION

Make sure the tool is free of nicks or sharp edges or damage to the seal may occur.

3. Repeat steps 1-2 for the opposite side.

INSTALLING DIFFERENTIAL

1. Place the differential assembly into position in the frame; then install the top mounting cap screw, two washers, and lock nut. Do not tighten at this time.
2. Install the lower differential mounting cap screw, washers, and lock nut. Note the correct location for the washers.

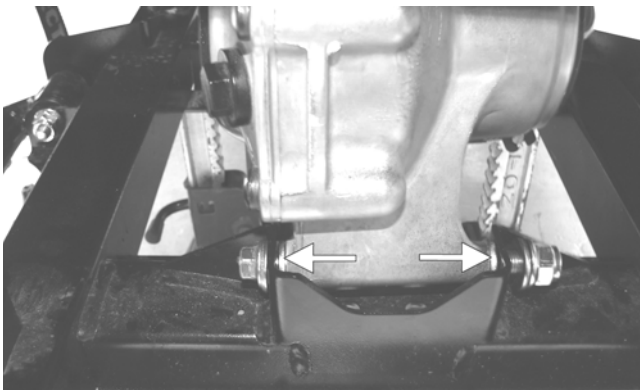

PR205A

3. Tighten the nuts to 38 ft-lb.
4. Pour 275 ml (9.3 fl oz) of SAE 80W-90 hypoid lubricant into the differential and install the fill plug. Tighten to 16 ft-lb.
5. Align the scribed match marks on the front input drive flange and the front drive yoke flange; then secure with the cap screws tightened to 20 ft-lb.

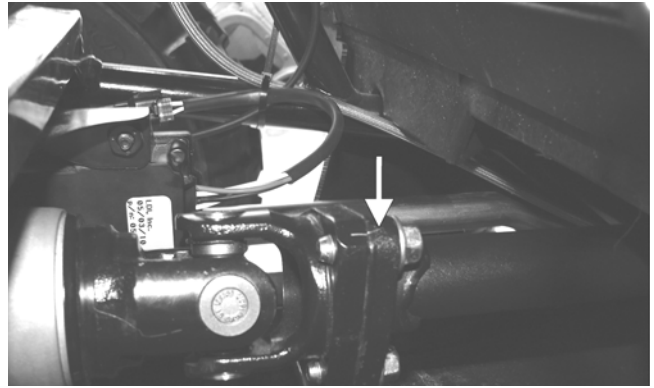

PR198A

6. Install the front axles.
7. Install the knuckle assemblies onto the axles and ball joints; then secure with four cap screws taking care not to damage the threads when installing. Tighten to 35 ft-lb.

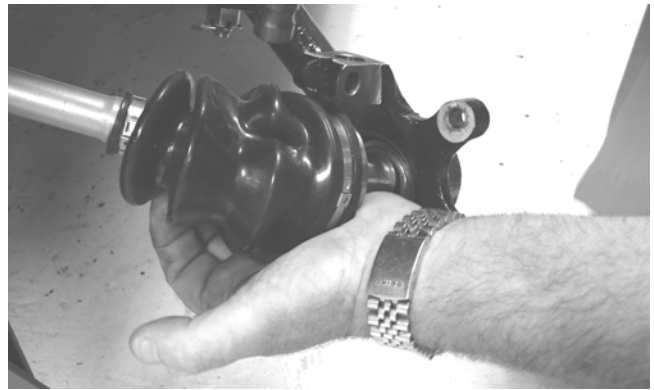

PR201

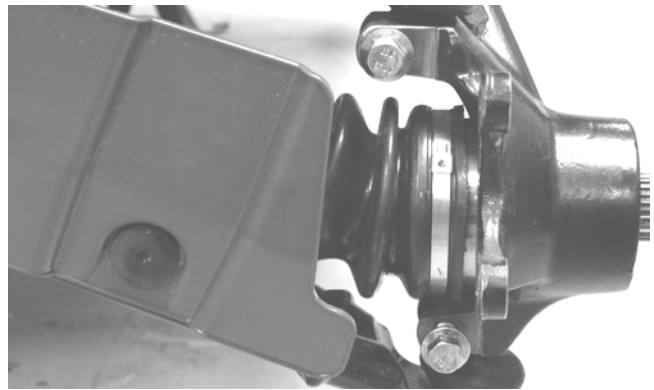

PR193

8. Secure the lower shock eyelets with cap screws and lock nuts. Tighten to 20 ft-lb.

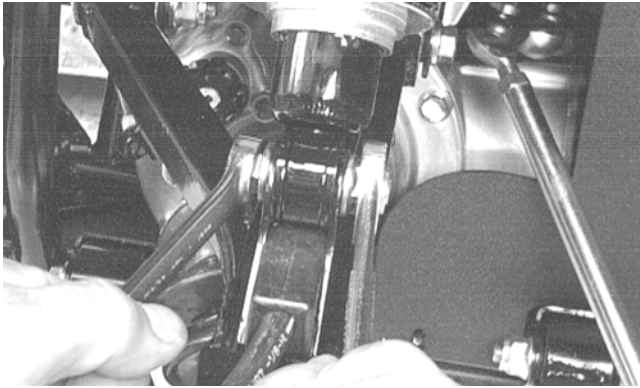

AF897D

9. Install the brake calipers. Secure with new “patch-lock” cap screws tightened to 20 ft-lb.

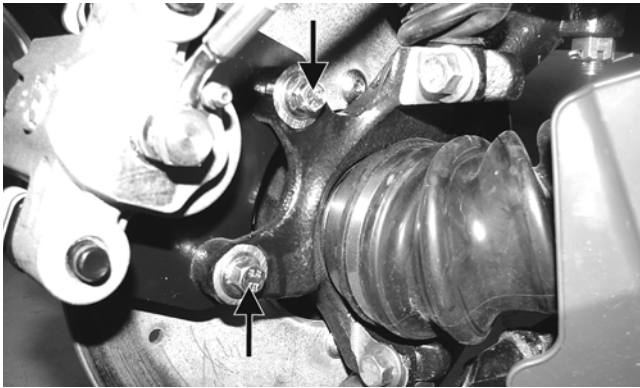

PR264A

10. Connect the front drive actuator connector to the main harness; then secure the wires to the frame with nylon ties.
11. Apply a light coat of multi-purpose grease to the hub splines; then install the hubs and nuts. Tighten to 200 ft-lb; then install new cotter pins.

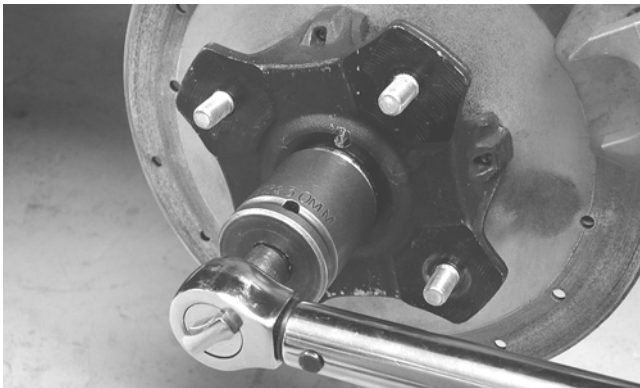

PR256

12. Install the wheels and tighten to 80 ft-lb.
13. Remove the vehicle from the support stand.
14. Install the belly panel.

Drive Axles

REMOVING REAR DRIVE AXLE

1. Secure the vehicle on a support stand to elevate the wheels.

⚠ WARNING

Make sure the vehicle is solidly supported on the support stand to avoid injury.

2. Place the transmission in park; then remove the wheels.
3. Remove the cotter pins securing the axle nuts; then remove the nuts.

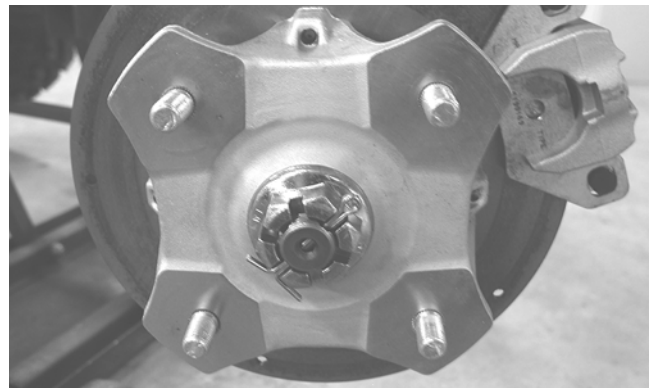

KX041

4. Slide the hub out of the knuckle and set aside.



PR221

5. Remove the cap screw and lock nut securing the knuckle to the upper A-arm. Discard the lock nut.

6

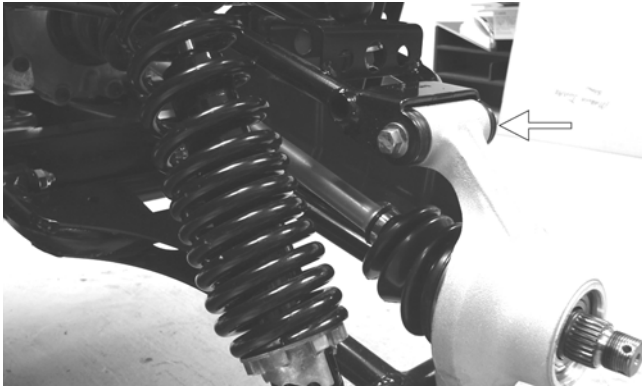

PR220A

6. While holding the drive axle stationary, pull the top of the knuckle out and down until it is free of the drive axle.



PR218

7. Place a drain pan under the vehicle to contain any oil leakage; then pushing the axle shaft in, pull the axle assembly from the gear case.

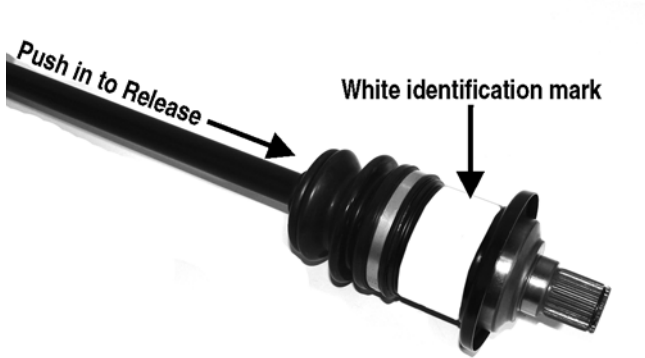

PR729B

REMOVING FRONT DRIVE AXLE

■NOTE: For removing a front drive axle, see Front Differential in this section.

CLEANING AND INSPECTING AXLES

■NOTE: Always clean and inspect the drive axle components to determine if any service or replacement is necessary.

1. Using a clean towel, wipe away any oil or grease from the axle components.

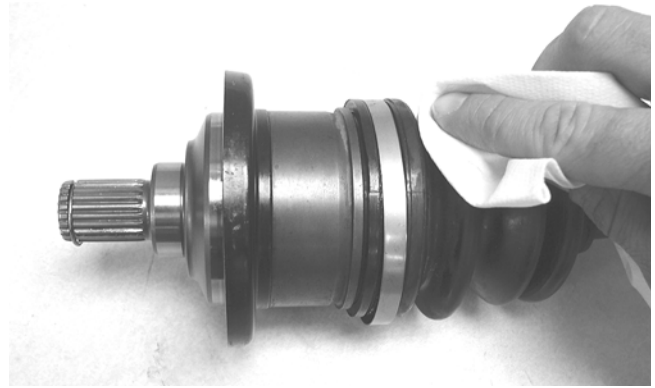

CD019

2. Inspect boots for any tears, cracks, or deterioration.

■NOTE: If a boot is damaged in any way, it must be replaced with a boot kit.

DISASSEMBLING AXLES

1. Using a side-cutters (or suitable substitute), remove the large clamp from the boot.

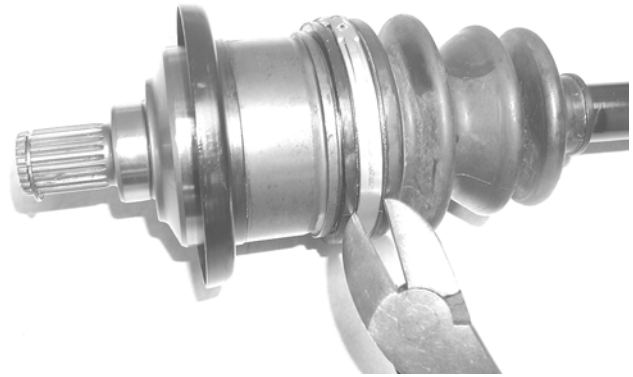

CD020

2. Wipe away excess grease to access the retaining ring. Using an awl or circlip pliers, remove the circlip.

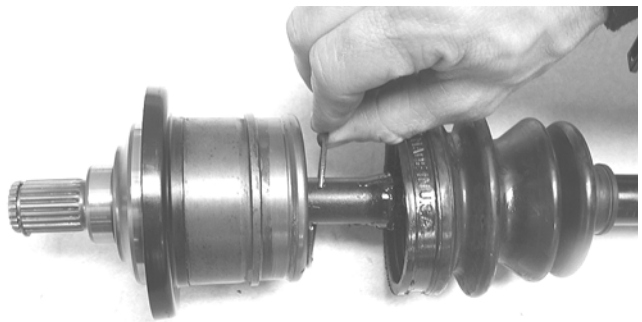

CD021

3. Using a snap ring pliers, remove the snap ring securing the bearing ring to the shaft. Note the direction of the bearing for assembling purposes.

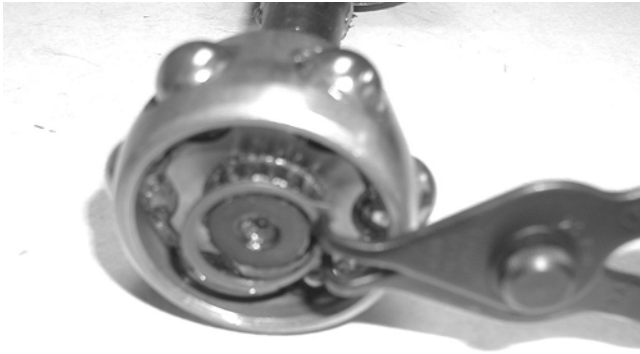

CD023

- Note the difference inside each bearing ring end for assembling purposes; then remove the bearing ring.

■NOTE: The recess of the bearing must face toward the housing.



CD022

- Inspect the splines of the shaft, the bearing ring, and the housing for damage.

■NOTE: If any damage is apparent to the splines, the bearing ring, and/or the housing, the drive axle must be replaced as an assembly.

- Using a side-cutters (or suitable substitute), remove the small clamp from the shaft.



CD752

■NOTE: At this point if the outside boot is damaged, continue with step 7.

- Using a side-cutters (or suitable substitute), remove both outside boot clamps from the shaft. Note the position of the different-sized clamps for assembling purposes.

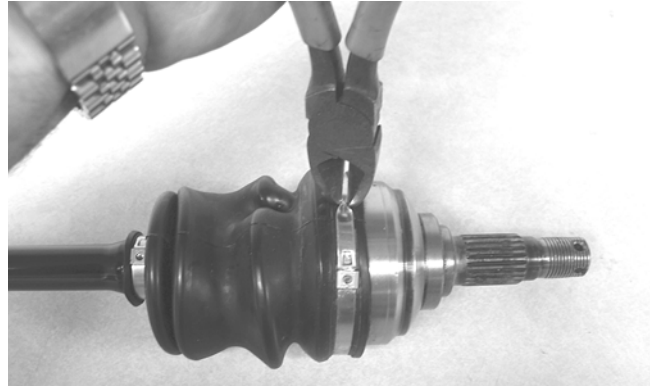

CD751

- Apply 40 grams (1/3 of contents) of grease from the grease pack included in Front Axle Boot Repair Kit into the knuckles and the new outside boot.

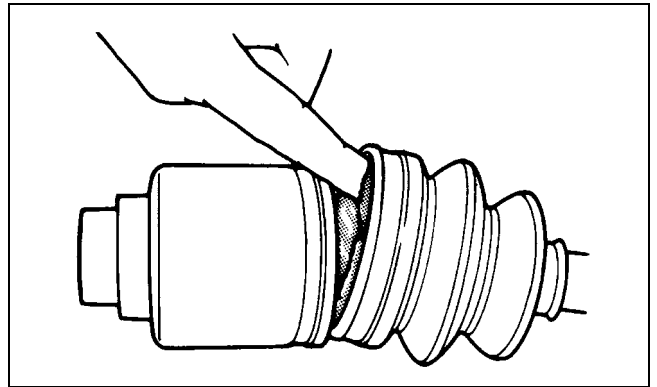

ATV-1052

■NOTE: The grease pack contains 120 grams of grease. The inside joint (double-offset) requires approximately 70-90 grams of grease and the outside (bell-type) requires approximately 35-55 grams. When replacing boots, use 2/3 of the pack for inside boots and 1/3 of the pack for outside boots.

CAUTION

Do no over-fill the joint as boot damage may occur resulting in joint failure.

- Slide the new outside boot onto the shaft with the new clamps positioned as shown. Note the different-sized clamps from removal.

■NOTE: The boot is positioned correctly when the small end of the boot seats down into the recessed groove.



CD754

10. Using CV Boot Clamp Tool, secure both outside boot clamps.

CAUTION

The clamps must be positioned correctly or they may loosen when in motion.

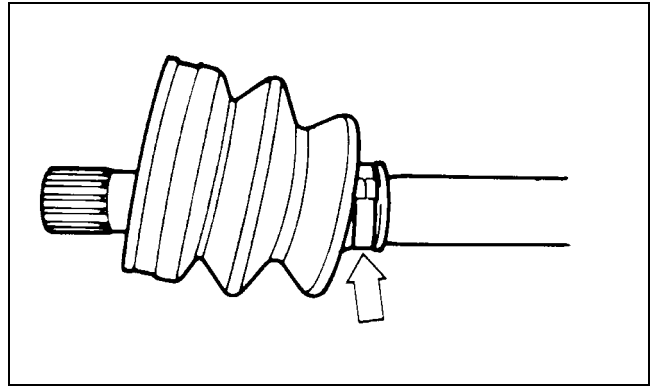

ATV-1048

3. Apply 80 grams (2/3 of contents) of grease from the pack into the bearing housing.
4. Install the bearing onto the shaft making sure the recess of the bearing is facing the housing.



CD024

ASSEMBLING AXLES

1. Install the inner boot with the small clamp making sure the ends of the clamp are positioned correctly.

■NOTE: The boot is positioned correctly when the small end of the boot seats down into the recessed groove.



CD754

2. Using the boot clamp tool, secure the small clamp of the inner boot.



CD022

CAUTION

The bearing ring must go onto the shaft with the side without splines facing toward the small clamp of the inner boot or severe damage will result.

5. Secure the bearing ring with the snap ring making sure the sharp side of the snap ring faces away from the boot.

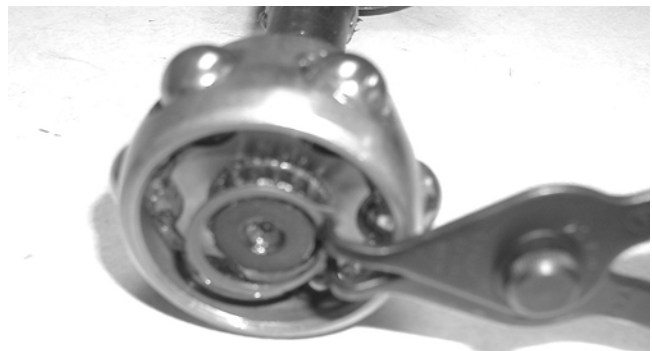

CD023

6. Making sure the marks made during disassembling align, slide the housing over the bearing ring; then completely seat the bearing ring into the housing and install the snap ring.

■NOTE: Pull the bearing ring out of the housing until it contacts the snap ring; then slide the ring in half way. This will purge air from the housing and ensure the bearing is packed properly.



CD021

7. Slide the boot over the housing; then using the boot clamp pliers, secure the boot with the clamp.



CD024

8. Inspect the axle components for correct positioning of the four clamps. Also, inspect the boots for being correctly positioned on the shaft.

INSTALLING REAR DRIVE AXLE

1. Push the axle shaft into the CV coupler to release the lock ring; then slide the drive axle into place in the gear case.



PR729B

■NOTE: To ensure proper axle seating, give it a light pull; the axle should remain “clipped” in place.

2. Swing the knuckle up and onto the drive axle; then place the knuckle into place in the upper A-arm. Secure the knuckle to the A-arm with a cap screw and a new lock nut. Tighten to 35 ft-lb.
3. Place the hub into position on the axle followed by a hex nut. Tighten the hex nut finger-tight at this time.
4. Tighten the hub hex nut (from step 3) to 200 ft-lb; then install and spread a new cotter pin making sure each side of the pin is flush to the hub nut.

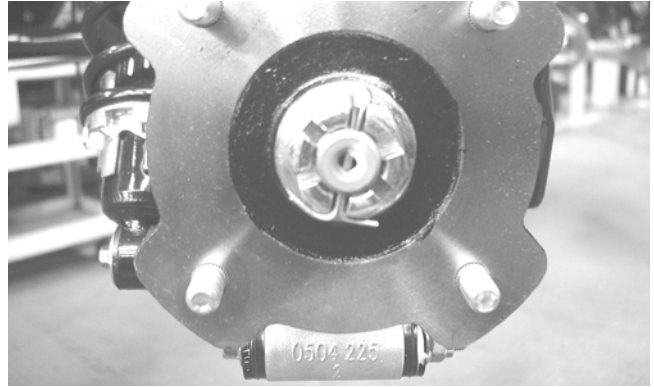

CD027

5. Install the wheel. Tighten to 80 ft-lb.
6. Remove the vehicle from the support stand and release the parking brake.

INSTALLING FRONT DRIVE AXLE

1. Push the axle shaft into the CV coupler to release the lock ring; then position the drive axle in the gear case and steering knuckle; then insert the ball joints into the steering knuckles. Secure with cap screws tightened to 35 ft-lb.
2. Secure the lower shock eyelet to the A-arm with a cap screw and a new lock nut. Tighten to 33 ft-lb.
3. Slide the hub w/brake disc into position in the steering knuckle followed by an axle nut. Finger-tighten at this time.
4. Install the brake caliper on the steering knuckle using new “patch-lock” cap screws. Tighten to 20 ft-lb.
5. Place the transmission in park; then turn the ignition switch to the ON position, select LOCK on the drive select switch. Turn the ignition switch to the OFF position.
6. Tighten the axle nut (from step 3) to 200 ft-lb; then install and spread a new cotter pin making sure each side of the pin is flush to the hub nut.

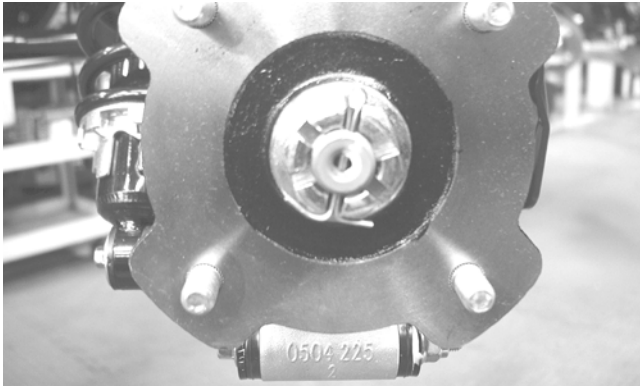

CD027

7. Install the wheel and tighten to 80 ft-lb.
8. Remove the vehicle from the support stand.
9. Check the front differential lubricant level and add lubricant as necessary.

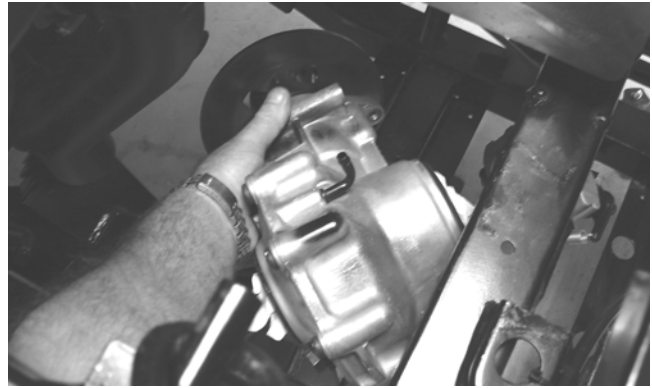

PR207

AT THIS POINT

For servicing the input shaft, pinion gear, needle bearing, ring gear, and axle seal, see Front Differential in this section.

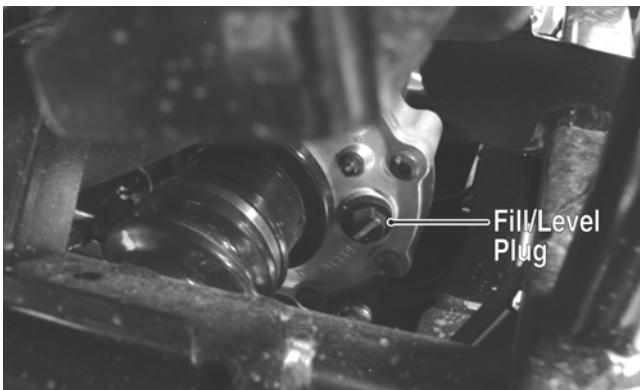

PR065A

Rear Gear Case

REMOVING

■NOTE: Release the cargo box latch and allow the cargo box to tilt back; then remove the cargo box lift support by removing the cap screw and nut securing the lower lift support to the frame. The cargo box will tilt fully rearward.

1. Drain the lubricant from the rear gear case; then remove both rear drive axles (see Drive Axles in this section).
2. Remove the driveline brake caliper; then cut the rear-most propeller shaft boot clamp and slide the boot forward.
3. Remove the boot clamps on the rear driveline boot.
4. Remove the two cap screws and lock nuts securing the rear gear case to the frame; then remove the gear case through the upper left-side of the frame and lift out the top.

RING GEAR/THRUST BUTTON

Removing

1. Remove the cap screws securing the gear case cover to the gear case; then remove the ring gear.
2. Remove the thrust button from the gear case cover (left-hand threads). Account for a shim.

Inspecting

1. Inspect the ring gear for excessive wear, missing or chipped teeth, or discoloration.
2. Inspect the thrust button for excessive wear or discoloration.
3. Inspect the bearings for discoloration, roughness, or excessive wear.

■NOTE: For servicing bearings or seals, see Front Differential in this section.

Installing/Shimming

■NOTE: Ring gear clearance must be adjusted prior to selecting shim for the thrust button.

1. Install the thrust button with shim into the gear case cover and tighten securely (left-hand threads).

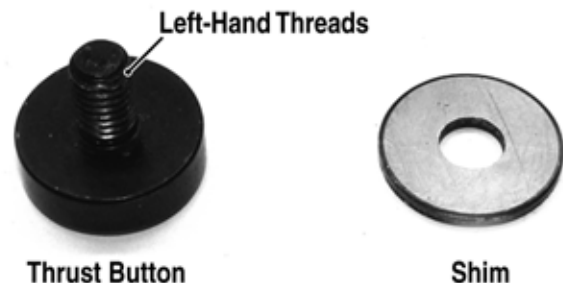

GC057A

- Place the ring gear with selected shim into the cover and measure the ring gear to thrust button clearance with a thickness gauge. Clearance should be 0.002-0.004 in.



GC058A

- If clearance is as specified, remove the ring gear and thrust button; then place a drop of red Loctite #271 on the threads and tighten to 8 ft-lb (left-hand threads).
- If clearance is not as specified, repeat steps 1 and 2 using thicker (clearance too great) or thinner (clearance too small) until correct specification is reached.

REAR DRIVE INPUT SHAFT/ HOUSING

Removing/Disassembling

- Remove the cap screws securing the rear drive input shaft/housing to the rear gear case; then remove the input housing assembly.



GZ183

- Remove the input shaft from the input housing; then remove the oil seal.



GZ180

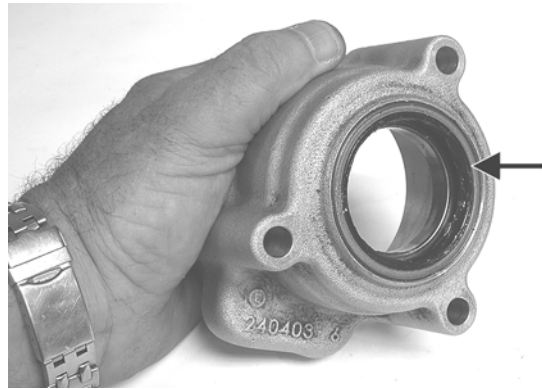

GZ182A

- Remove the snap ring retaining the input bearing and using an appropriate bearing driver, press the bearing from the housing.



GZ184A

6

Cleaning and Inspecting

- Wash all parts in parts cleaning solvent and dry with compressed air.

⚠ WARNING

Always wear safety glasses when working with compressed air.

- Clean all gasket material and sealant from mating surfaces.
- Inspect bearings, shafts, and housing for excessive wear, cracks, or discoloration.

Assembling/Installing

1. Install a new bearing into the input housing and secure with the snap ring (flat side directed away from bearing).

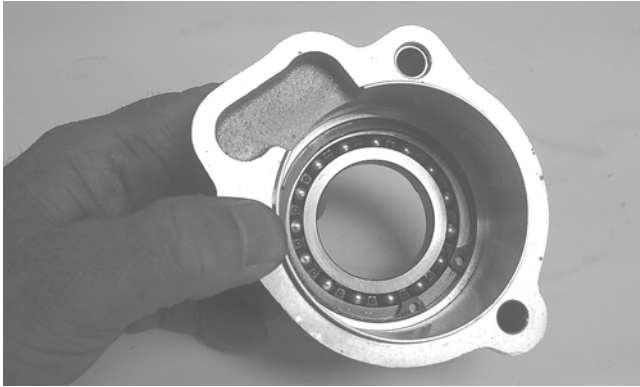

GZ184

2. Using a suitable seal driver, install a new oil seal into the front of the input housing until the seal flush with the housing.

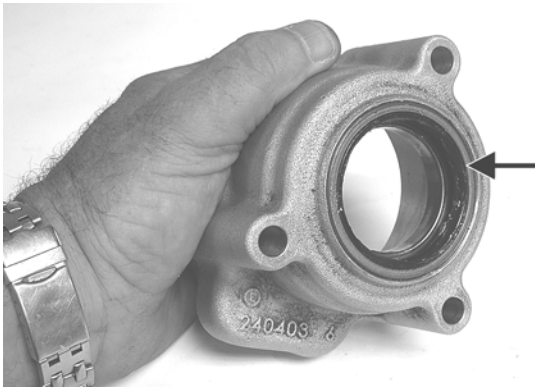

GZ182A

3. Apply grease to the lips of the oil seal; then install the input shaft into the input bearing and housing.



GZ179A

4. Using a new gasket, install the assembled rear drive input shaft/housing onto the rear drive gear case and secure with the three cap screws. Tighten to 23 ft-lb.

AT THIS POINT

For servicing the input shaft, pinion gear, needle bearing, and axle seal, see Front Differential in this section.

INSTALLING

1. Slide the gear case into position down through the upper-left side of the frame; then align the driveline splines to the differential input coupler and engage the driveshaft and differential.
2. Pack the driveline boot with the appropriate grease; then secure with the boot clamps using CV Boot Clamp Tool.
3. Secure the differential to the frame with two through-bolts and secure with lock nuts and flat washers. Tighten to 38 ft-lb.
4. Install the rear drive axles (see Drive Axles in this section).
5. Install the brake caliper and tighten the mounting cap screws to 20 ft-lb.
6. Fill the gear case with the appropriate lubricant.

Hub

REMOVING

1. Secure the vehicle on a support stand to elevate the wheel; then remove the wheel.

■ **NOTE:** Removing or tightening of the hub nuts requires the axles be locked. To lock the rear axle, place the transmission in park. To lock the front axle, turn the ignition switch to ON, and select LOCK on the drive select switch; then place the transmission in park and turn the ignition switch to OFF.

WARNING

Make sure the vehicle is solidly supported on the support stand to avoid injury.

2. Remove the cotter pin from the axle.

■ **NOTE:** During assembly, new cotter pins should be installed.

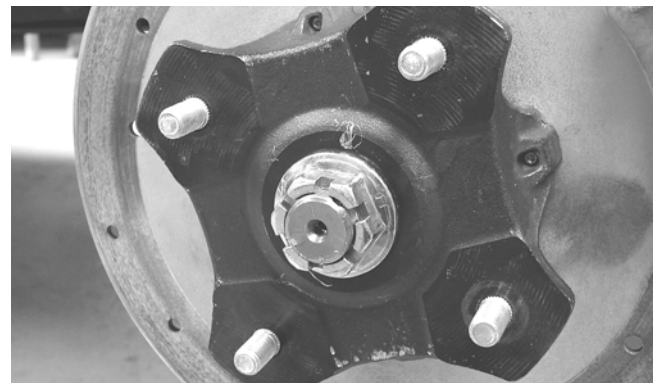

PR257

3. Remove the hub nut securing the hub.
4. Remove the brake caliper (front only).

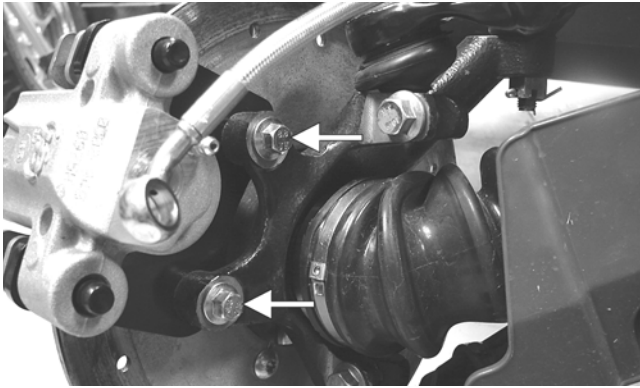

PR243A

5. Remove the hub assembly.
6. Remove the four cap screws securing the brake disc.

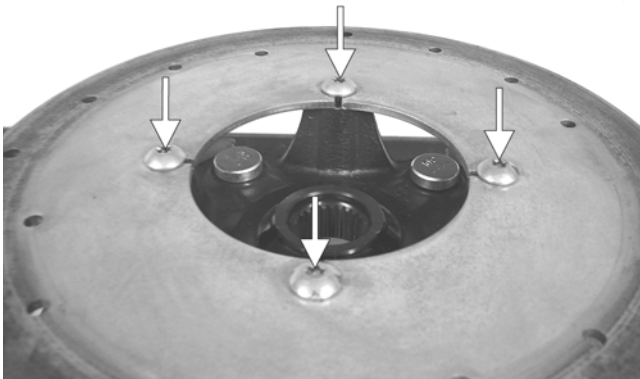

PR254A

CLEANING AND INSPECTING

■NOTE: Whenever a part is worn excessively, cracked, or damaged in any way, replacement is necessary.

1. Clean all hub components.
2. Inspect all threads for stripping or damage.
3. Inspect the brake disc (if applicable) for cracks or warping.
4. Inspect the hub for pits, cracks, loose studs, or spline wear.

REPLACING WHEEL STUDS

1. Secure the hub in a suitable holding fixture and remove the brake disc (if applicable).
2. Drive the damaged stud out of the hub; then place the new stud into the hub and thread on an appropriate flange nut.

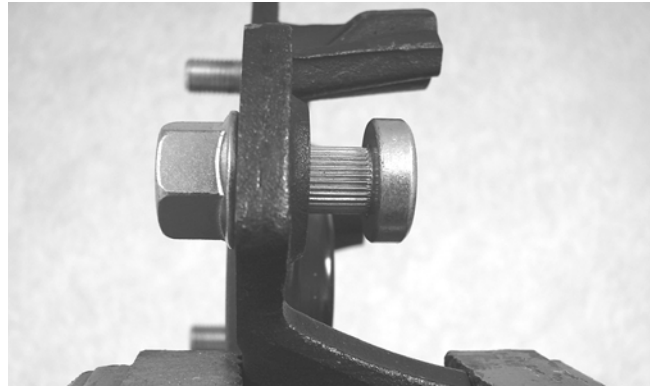

PR250

3. Using a socket and ratchet handle, tighten the nut until the stud is fully drawn into the hub.

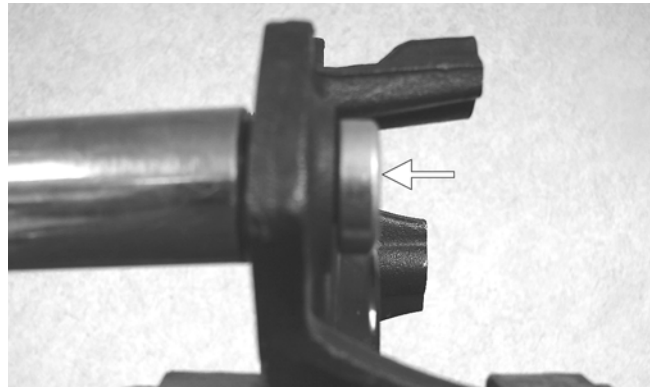

PR252A

INSTALLING

1. Secure the brake disc (if applicable) to the hub with the four cap screws coated with red Loctite #271. Tighten to 15 ft-lb.
2. Apply grease to the splines in the hub.

6



PR254B

3. Install the hub assembly onto the axle; then place the transmission in park.



PR221

- Secure the hub assembly with the nut. Tighten to 200 ft-lb; then secure with a new cotter pin.

■NOTE: If the cotter pin can not be inserted due to misalignment of the hole in the axle and the slots in the nut, tighten the nut until properly aligned.

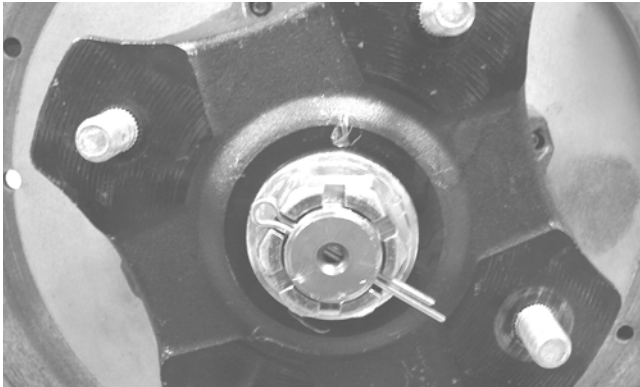

PR258

- Secure the brake calipers to the knuckle with two new “patch-lock” cap screws tightened to 20 ft-lb.

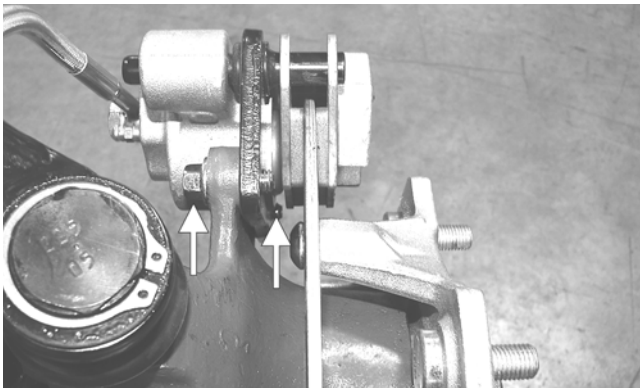

PR377B

- Install the wheel and tighten to 80 ft-lb.
- Remove the vehicle from the support stand.

Hydraulic Brake Caliper

⚠ WARNING

Arctic Cat recommends only authorized Arctic Cat ROV dealers perform hydraulic brake service. Failure to properly repair brake systems can result in loss of control causing severe injury or death.

REMOVING/DISASSEMBLING

- Secure the vehicle on a support stand to elevate the wheel; then remove the wheel.

⚠ WARNING

Make sure the vehicle is solidly supported on the support stand to avoid injury.

⚠ WARNING

Never let brake fluid contact the eyes. Damage to the eyes will occur. Always wear appropriate protective safety goggles and latex gloves when handling brake fluid.

- Drain the brake fluid from the caliper, hose, and master cylinder through the bleed screw by pumping the brake pedal.

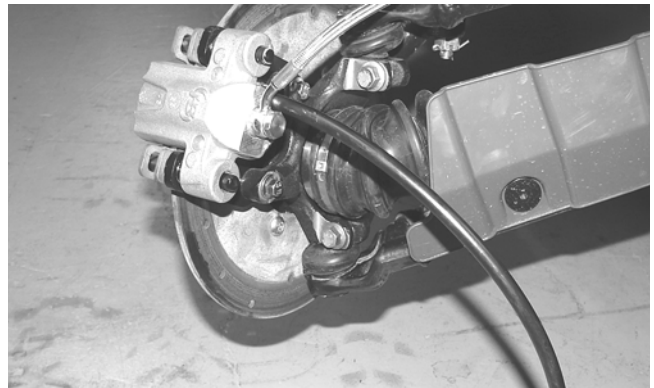

PR235

CAUTION

Brake fluid is highly corrosive. Do not spill brake fluid on any surface of the vehicle and do not reuse brake fluid.

■NOTE: Whenever brake components are removed, disassembled, or repaired where brake fluid is exposed to air, drain all fluid and replace with new DOT 4 brake fluid from an unopened container. Brake fluid readily absorbs moisture from the air significantly lowering the boiling point. This increases the chance of vapor lock reducing braking power and increasing stopping distance.

- Remove the brake hose from the caliper and close the bleed screw; then remove the caliper.

- Compress the caliper holder against the caliper (opposite the O-ring side) and remove the outer brake pad; then remove the inner brake pad.

■NOTE: If brake pads are to be returned to service, do not allow brake fluid to contaminate them.



PR237A



PR238

- Remove the caliper holder from the caliper and discard the O-ring.

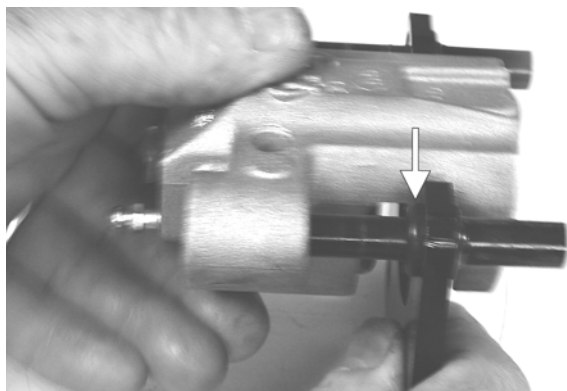

PR239B

■NOTE: The O-ring is used for shipping purposes and provides no function in operation.

- Cover the piston end of the housing with a shop towel; then keeping fingers clear of piston travel, apply compressed air to the fluid port to blow the piston free of the housing. Account for two seal rings in the housing.

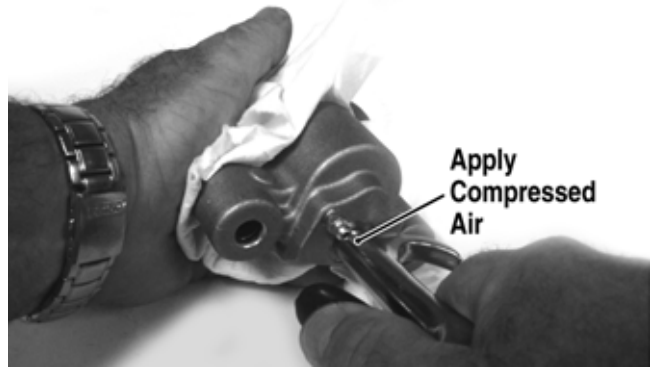

PR713A



PR715

⚠ WARNING

Make sure to hold the towel firmly in place or the piston could be ejected from the housing causing injury.

- Using an appropriate seal removal tool, carefully remove the seals from the brake caliper housing; then remove four O-rings from the brake caliper housing noting the location of the different sized O-rings. Discard all seals, O-rings, and crush washers.

6

CLEANING AND INSPECTING

- Clean all caliper components (except the brake pads) with DOT 4 brake fluid. Do not wipe dry.
- Inspect the brake pads for damage and excessive wear.

■NOTE: For measuring brake pads, see Section 2.

- Inspect the brake caliper housings for scoring in the piston bores, chipped seal ring grooves, or signs of corrosion or discoloration.
- Inspect the piston surface for scoring, discoloration, or evidence of binding or galling.
- Inspect the caliper holder for wear or bending.

ASSEMBLING/INSTALLING

- Install new seals into the brake caliper housing and apply a liberal amount of DOT 4 brake fluid to the cylinder bore of the housing, seals, and brake piston.

CAUTION

Make sure the seals are properly in place and did not twist or roll during installation.



PR715

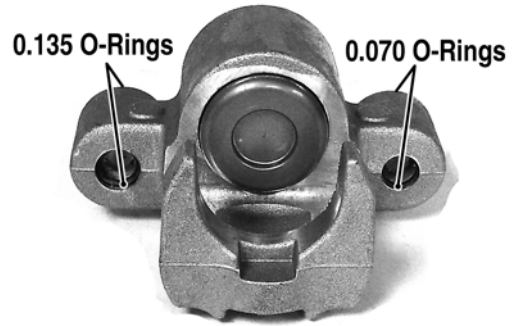

PR719C

4. Install the caliper onto the caliper holder making sure the caliper and holder are correctly oriented.

■NOTE: It is very important to apply silicone grease to the O-rings and caliper bores prior to assembly.

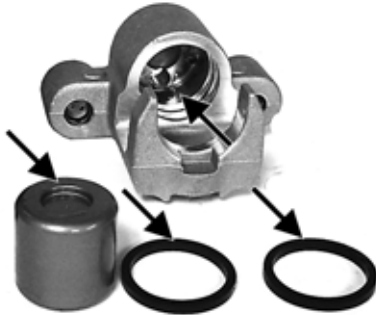

PR717A

2. Press the piston into the caliper housing using hand pressure only. Completely seat the piston; then wipe off any excessive brake fluid.

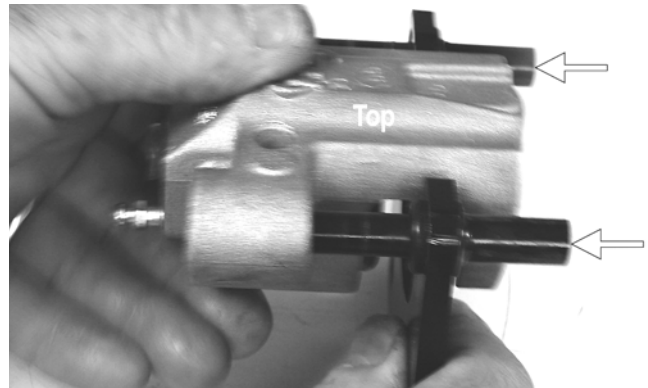

PR239C

5. Making sure brake fluid does not contact the brake pads, compress the caliper holder toward the caliper and install the inner brake pad; then install the outer pad.



PR711A

CAUTION

If brake pads become contaminated with brake fluid, they must be thoroughly cleaned with brake cleaning solvent or replaced with new pads. Failure to do so will result in reduced braking and premature brake pad failure.



PR712

3. Apply high-temperature silicone grease (supplied with the O-ring kit) to the inside of the caliper holder bores and O-rings; then install the four O-rings into the caliper.

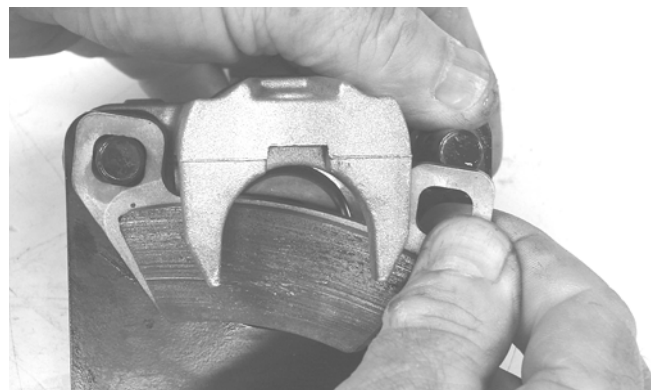

PR238

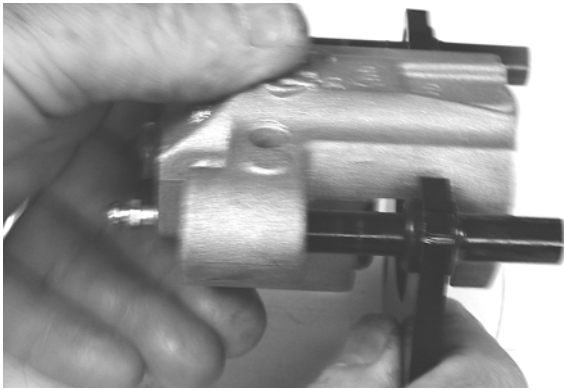

PR239

6. Place the brake caliper assembly into position and secure with new “patch-lock” cap screws. Tighten the caliper to 20 ft-lb.
7. Place a new crush washer on each side of the brake hose fitting and install it on the caliper. Tighten to 20 ft-lb.
8. Fill the reservoir; then bleed the brake system (see Section 2).

⚠ WARNING

Never use brake fluid from an open container or reuse brake fluid. Moisture-contaminated brake fluid could cause vapor build-up (expansion) during hard braking resulting in greatly increased stopping distance or loss of control leading to injury or death.

9. Install the wheel. Tighten to 80 ft-lb.
10. Remove the vehicle from the support stand and verify brake operation.

MASTER CYLINDER ASSEMBLY

■NOTE: The master cylinder is a non-serviceable component; it must be replaced as an assembly.

Removing

1. Slide a piece of flexible tubing over one of the wheel bleeder valves and direct the other end into a container. Remove the reservoir cover; then open the bleeder valve. Allow the brake fluid to drain until the reservoir is empty.



AF637D

2. Remove the cotter pin and pivot pin from the yoke; then remove two cap screws and flange nuts securing the master cylinder assembly to the frame.

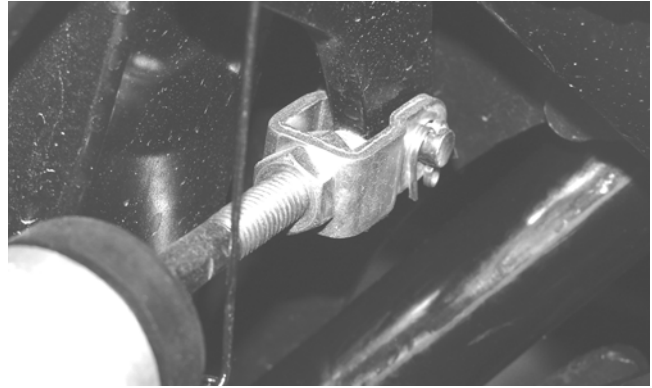

PR338



PR336

3. Remove the oil bolt securing the banjo-fittings to the master cylinder; then remove the master cylinder. Discard the three crush washers.

CAUTION

Brake fluid is highly corrosive. Do not spill brake fluid on any surface of the vehicle.

Inspecting

1. Inspect the master cylinder push rod and clevis for wear, bending, or elongation of clevis holes.
2. Inspect the push rod boot for tears or deterioration.
3. Inspect the reservoir for cracks and leakage.
4. Inspect the brake hose for cracks and deterioration and the condition of the banjo-fittings.

Installing

1. Place the master cylinder into position; then using three new crush washers, secure the two banjo-fittings to the master cylinder. Tighten to 20 ft-lb.
2. Secure the master cylinder assembly to the frame with two cap screws and two flange nuts. Tighten to 25 ft-lb.
3. Install the pivot pin and secure with a new cotter pin.
4. Fill the master cylinder and bleed the brake system (see Hydraulic Brake System in Section 2).

Universal Joints

REMOVING

■NOTE: The universal joints can be accessed by removing the belly panel. To remove the belly panel, see Belly Panel in Section 8.

1. Support the vehicle on suitable jack stands elevated high enough to allow working from the underside of the vehicle.
2. To aid in installing, match mark drive-line components prior to removing.
3. Remove the cap screws securing the driveshaft flange to the output flange; then remove the driveshaft.

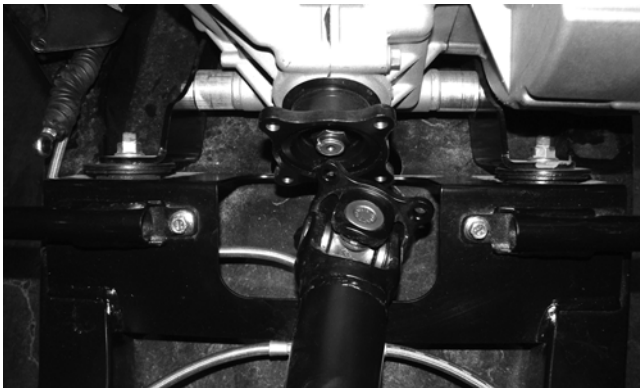

HDX157

4. Install U-Joint Separator Tool on the universal joint fixed yoke; then remove the bearing cup retainers.
5. Using a suitable socket and ratchet handle, rotate the jackscrew to push the bearing cup out of the yoke; then remove the tool and the bearing cup.



PR359

6. Install the separator tool on the opposite side of the yoke to push the second bearing cup from the yoke; then remove the tool and separate the universal joint.
7. Secure the separator tool in a vise and repeat steps 4-6 to remove the bearing cups from the movable yoke.

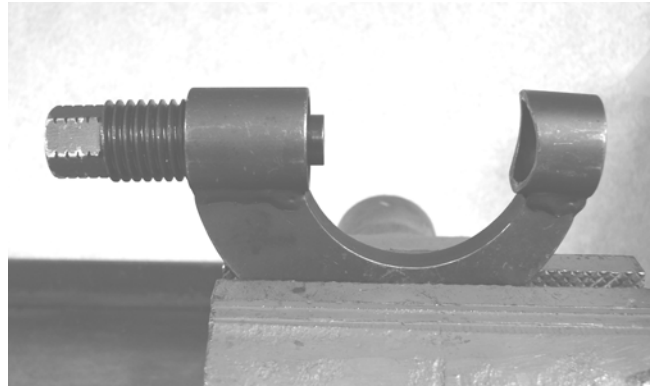

PR375

INSPECTING

1. Inspect the yoke bores for damage or signs of bearing cup looseness. If bearing cups are loose, the yoke must be replaced.



PR367B

2. Check that yoke legs are parallel.

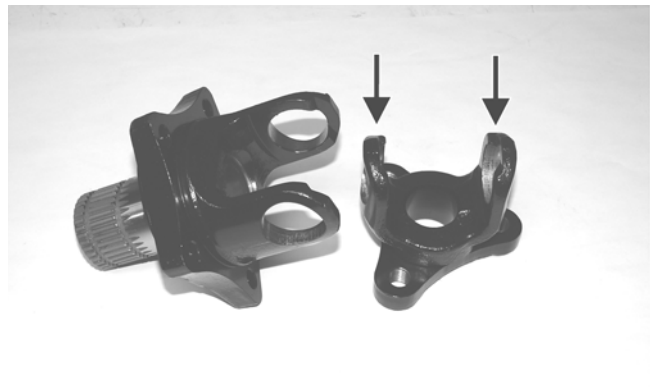

PR367A

3. Check splines and flanges for excessive wear, thread damage, or warpage.



PR367C

INSTALLING

1. Remove the bearing cups from the universal joint; then insert the joint into the yoke and install one bearing cup on the joint.

CAUTION

Care must be taken when installing bearing cups that the needle bearings stay in place or severe damage to the universal joint will occur.



PR368

2. Secure U-Joint Separator Tool in a vise; then place the yoke, joint, and bearing cup into position and press the cup into the yoke.

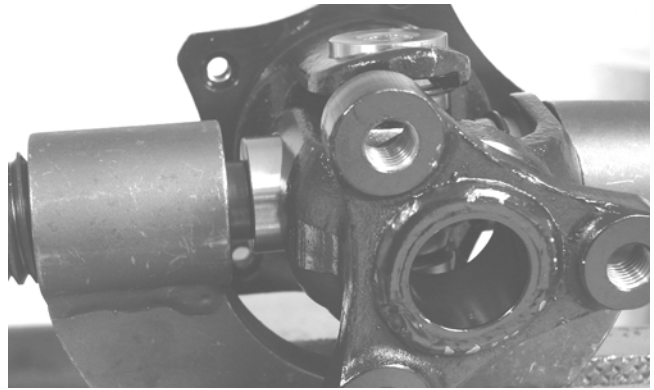

PR374

3. Install the retainer in the bearing cup; then remove the yoke from the separator tool.

■NOTE: Repeat steps 2-3 for the opposite-side bearing cup.

4. Remove the separator tool from the vise and install the universal joint, bearing cups, and movable yoke into the fixed yoke using the same procedure as steps 2-3 except the vise cannot be used.

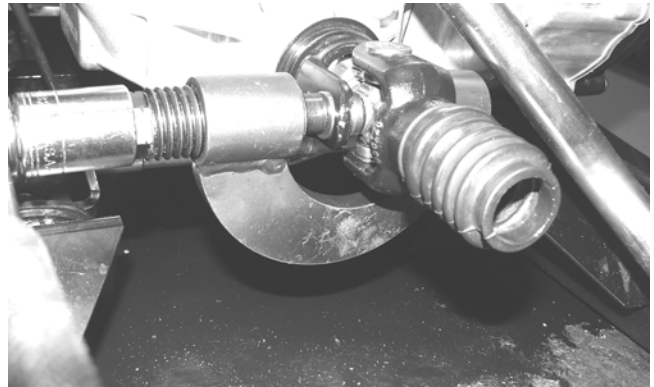

PR355

5. Check that the universal joint can be flexed freely without binding; then apply multi-purpose grease to the splines and install the driveshaft noting the match marks made prior to removing.

Troubleshooting

Problem: Power not transmitted from engine to wheels

Condition	Remedy
1. Rear axle shaft serration worn - broken	1. Replace shaft

Problem: Power not transmitted from engine to either front wheel

Condition	Remedy
1. Secondary drive - driven gear teeth broken	1. Replace gear(s)
2. Propeller shaft serration worn - broken	2. Replace shaft
3. Coupling damaged	3. Replace coupling
4. Coupling joint serration worn - damaged	4. Replace joint
5. Front drive - driven bevel gears broken - damaged	5. Replace gear(s)
6. Front differential gears/pinions broken - damaged	6. Replace gears - pinions
7. Front drive actuator not operating	7. Replace fuse - drive select switch - front drive actuator

SECTION 7 - SUSPENSION

TABLE OF CONTENTS

Suspension 7-2
Shock Absorbers 7-2
Front A-Arms 7-3
Rear A-Arms 7-5
Wheels and Tires 7-6
Troubleshooting 7-8

Suspension

■NOTE: Critical torque specifications are located in Section 1.

The following suspension system components should be inspected periodically to ensure proper operation.

- A. Shock absorber rods bent, pitted, or damaged.
- B. Rubber damper cracked, broken, or missing.
- C. Shock absorber body damaged, punctured, or leaking.
- D. Shock absorber eyelets broken, bent, or cracked.
- E. Shock absorber eyelet bushings worn, deteriorated, cracked, or missing.
- F. Shock absorber spring broken or sagging.
- G. Sway bar mountings tight and bushings secure.

Shock Absorbers

REMOVING

1. Secure the vehicle on a support stand to elevate the wheels and to release load on the suspension.

⚠ WARNING

Make sure the vehicle is solidly supported on the support stand to avoid injury.

2. Remove the two cap screws and nuts securing each front shock absorber to the frame and upper A-arm. Account for bushings and sleeves from each.

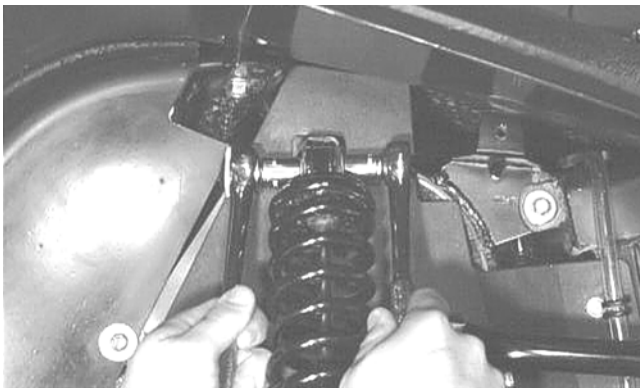

AF605D

CAUTION

Additional support stands are necessary to support the rear axle when the shock absorbers are removed or damage may occur.

3. Remove the two cap screws and nut securing each rear shock absorber to the frame and lower A-arm. Account for bushings and sleeves from each.

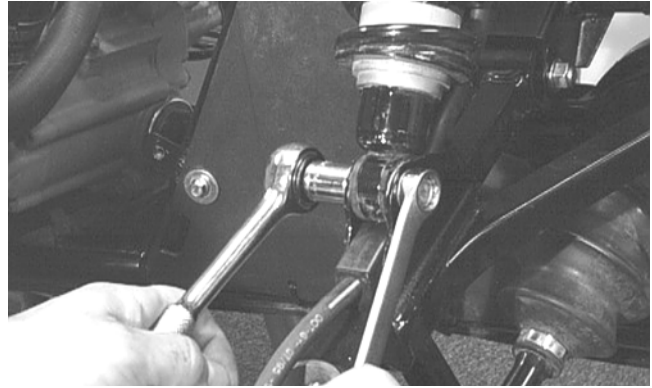

AF626D

4. Using a suitable spring compression stand, compress the shock absorber spring, remove the retainer, and remove the spring.

⚠ WARNING

Shock absorber springs are under high compression loads. Do not attempt to remove springs without an adequate spring compressor. Severe injury could result.



AF730D

CLEANING AND INSPECTING

■NOTE: Whenever a part is worn excessively, cracked, or damaged in any way, replacement is necessary.

1. Clean all shock absorber components in parts-cleaning solvent.
2. Inspect each shock rod for nicks, pits, rust, bends, and oily residue.
3. Inspect all springs, spring retainers, shock rods, sleeves, bushings, shock bodies, and eyelets for cracks, leaks, and bends.

INSTALLING

1. Place the shock absorber spring over the shock absorber, compress the spring, and install the retainer.
2. Place bushings and sleeves (where appropriate) into shock eyelet; then install shocks with two cap screws and nuts.

3. Tighten the front shock absorber cap screws to 33 ft-lb and the rear shock absorber cap screws to 33 ft-lb (upper) or 20 ft-lb (lower).
4. Remove the vehicle from the support stand.

Front A-Arms

REMOVING

1. Secure the vehicle on a support stand to elevate the front wheels; then remove the wheels.

WARNING

Make sure the vehicle is solidly supported on the support stand to avoid injury.

2. Remove the cotter pin from the nut. Discard the cotter pin.

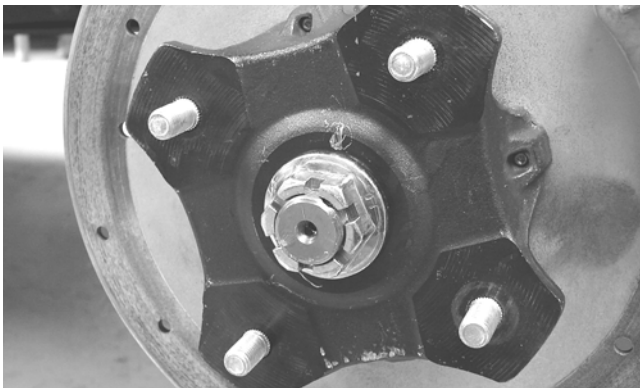

PR257

3. Remove the nut securing the hub.
4. Remove the brake caliper. Account for two cap screws.

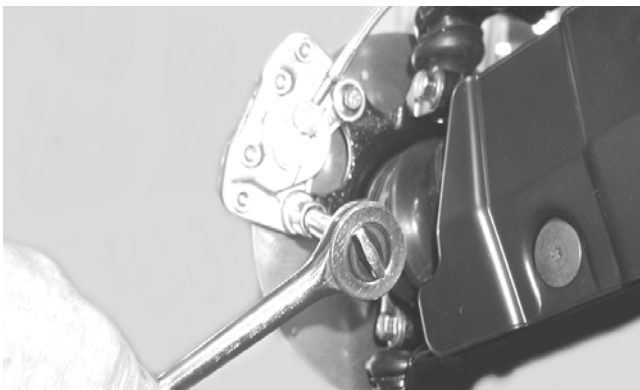

CD007

5. Remove the hub assembly.
6. Remove the cotter pin and slotted nut securing the tie rod end to the knuckle; then remove the tie rod end from the knuckle.

7. Remove the cap screws securing the ball joints to the knuckle.

CAUTION

Support the knuckle when removing the cap screws or damage to the threads will occur.

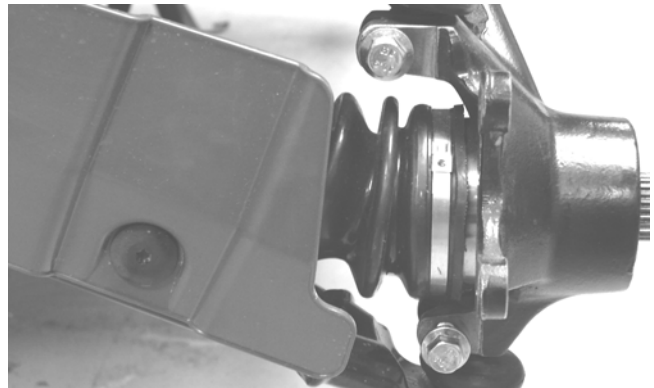

PR193

8. Tap the ball joints out of the knuckle; then remove the knuckle.
9. Remove the lower shock absorber eyelet from the upper A-arm.



AF626D

10. Remove the cap screws securing the A-arms to the frame.

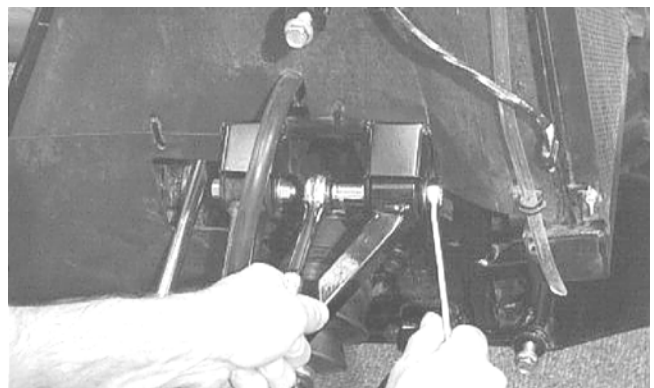

AF610D

11. Remove the snap ring from the ball joint; then remove the ball joint from the A-arm.

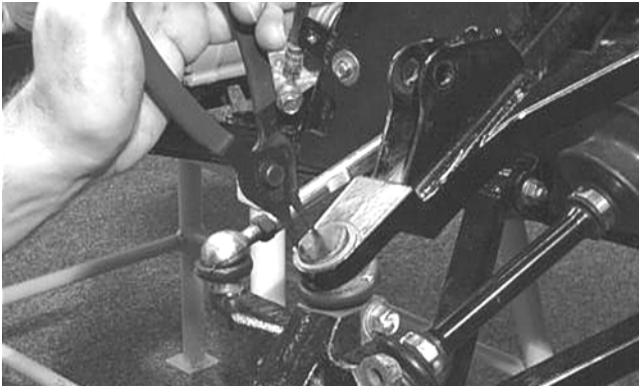

AF616D

CLEANING AND INSPECTING

■NOTE: Whenever a part is worn excessively, cracked, or damaged in any way, replacement is necessary.

1. Clean all A-arm components in parts-cleaning solvent.
2. Clean the ball joint mounting hole of all residual Loctite, grease, oil, or dirt for installing purposes.
3. Inspect the A-arm for bends, cracks, and worn bushings.
4. Inspect the ball joint mounting holes for cracks or damage.
5. Inspect the frame mounts for signs of damage, wear, or weldment damage.

INSTALLING

1. Apply Loctite Primer "T" to the A-arm socket; then apply green Loctite #609 to the entire outside diameter of the ball joint. Install the ball joint into the A-arm and secure with the snap ring.

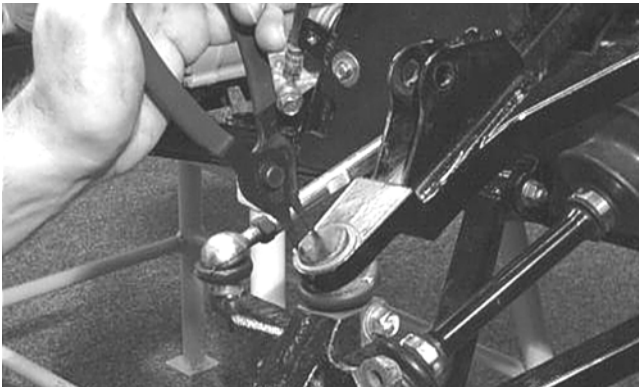

AF616D

2. Install the A-arm assemblies into the frame mounts and secure with the cap screws. Only finger-tighten at this time.

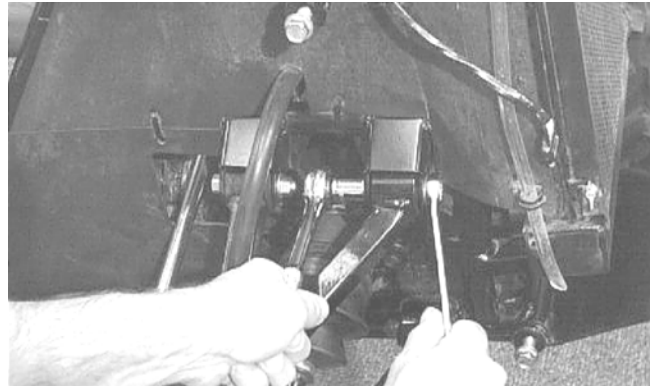

AF610D

3. Route the brake hose through the upper A-arm shock absorber mount.



AF627D

4. Secure the lower eyelet of the shock absorber to the upper A-arm. Tighten nut to 33 ft-lb.
5. Secure the A-arm assemblies to the frame mounts (from step 2). Tighten the cap screws to 33 ft-lb.
6. Install the knuckle assembly onto the ball joints and secure with cap screws. Tighten to 35 ft-lb.

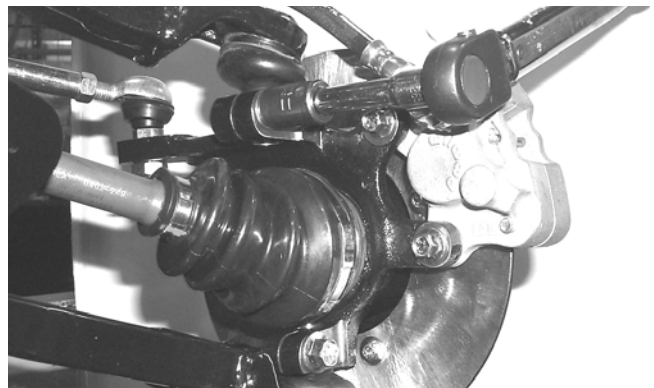

AF628D

7. Install the tie rod end and secure with the nut (coated with red Loctite #271). Tighten to 30 ft-lb; then install a new cotter pin and spread the pin to secure the nut.

■NOTE: During assembly, new cotter pins should be installed.

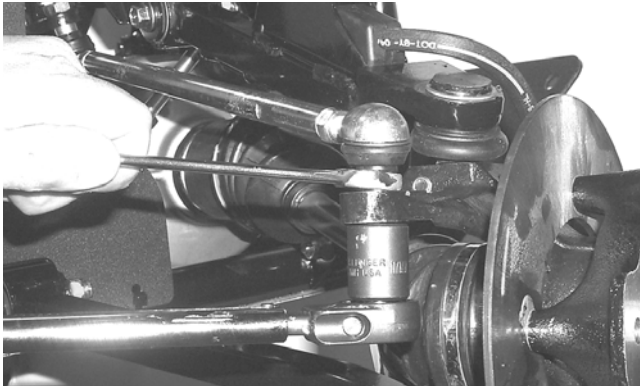

AF618D

- Apply grease to the hub and drive axle splines; then install the hub assembly onto the drive axle.

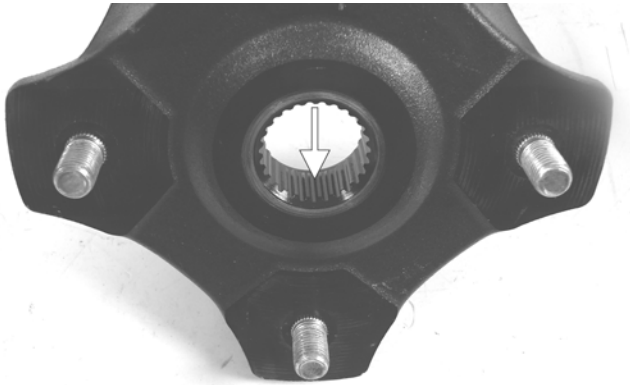

PR290A

- Secure the hub assembly with the nut. Tighten only until snug.
- Secure the brake caliper holder to the knuckle with two new “patch-lock” cap screws. Tighten to 20 ft-lb.

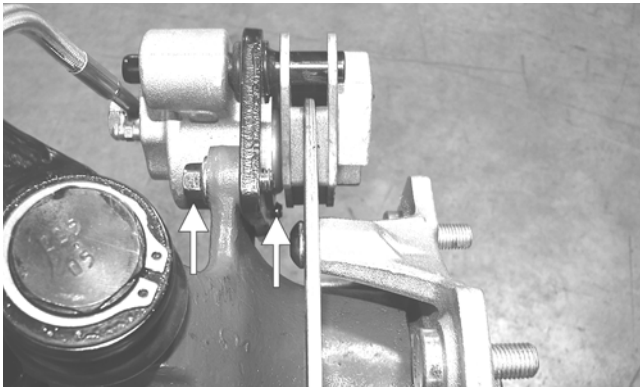

PR377B

- Secure the hub nut (from step 9) to the shaft/axle. Tighten to 200 ft-lb.
- Install a new cotter pin and spread the pin to secure the nut.

■ **NOTE:** If the cotter pin can not be inserted due to misalignment of the hole in the axle and the slots in the nut, tighten the nut until properly aligned.

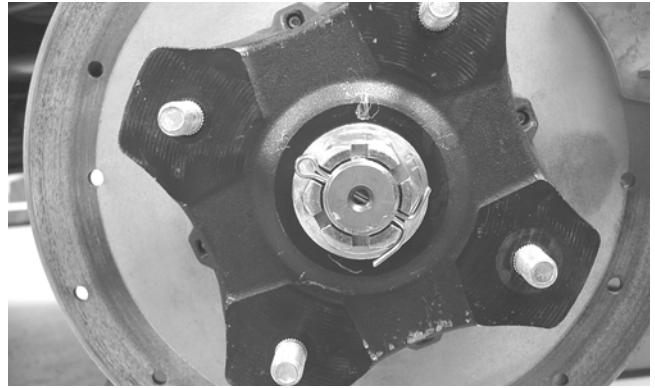

PR260

- Install the wheel and tighten to 80 ft-lb.
- Remove the vehicle from the support stand.

Rear A-Arms

REMOVING

- Secure the vehicle on a support stand to elevate the wheels.

⚠ WARNING

Make sure the vehicle is solidly supported on the support stand to avoid injury.

- Place the transmission in park.
- Remove the wheel.
- Remove the cotter pin securing the hex nut; then remove the hex nut.
- Remove the cap screws and lock nut securing the shock absorber to the frame and lower A-arm; then remove the shock absorber.
- Remove the cap screws securing the boot guard to the lower A-arm.

7



AF934

- Slide the axle out of the knuckle and set aside.
- Remove the cap screws and lock nuts securing the knuckle to the A-arms. Discard the lock nuts.

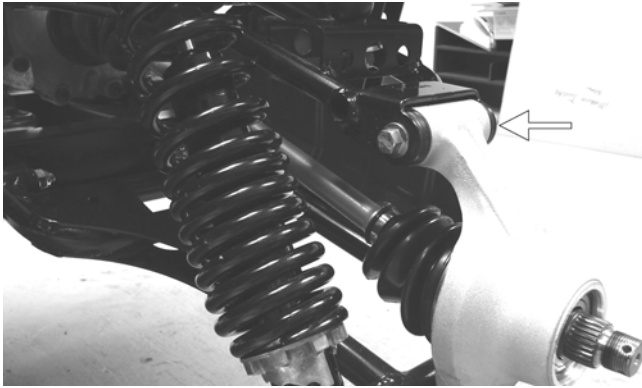

PR220A

■NOTE: Never reuse a lock nut. Once a lock nut has been removed, it must be replaced with a new lock nut.

9. Remove the cap screws and lock nuts securing the A-arms to the frame; then remove the A-arms.

CLEANING AND INSPECTING

■NOTE: Whenever a part is worn excessively, cracked, or damaged in any way, replacement is necessary.

1. Clean all A-arm components in parts-cleaning solvent.
2. Inspect the A-arm for bends, cracks, and worn bushings.
3. Inspect the frame mounts for signs of damage, wear, or weldment damage.

INSTALLING

1. Install the A-arm assemblies into the frame mounts and secure with the cap screws and new lock nuts. Finger-tighten only at this time.
2. Slide the knuckle onto the drive axle and into position on the A-arms; then secure the knuckle to the A-arms with cap screws and new lock nuts. Tighten to 35 ft-lb.
3. Tighten the hardware securing the A-arms to the frame mounts (from step 1) to 33 ft-lb.
4. Apply grease on the drive axle splines; then install the hub assembly onto the drive axle.



PR221

5. Secure the hub assembly with the nut. Tighten to 200 ft-lb.

6. Install a new cotter pin and spread the pin to secure the nut.

■NOTE: If the cotter pin can not be inserted due to misalignment of the hole in the axle and the slots in the nut, tighten the nut until properly aligned.

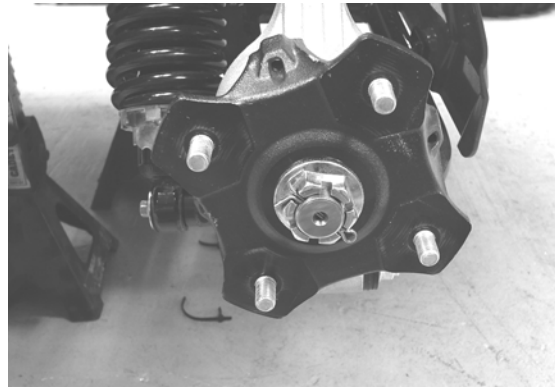

PR196

7. Secure the shock absorber to the frame with a cap screw and new lock nut. Tighten to 33 ft-lb.
8. Secure the shock absorber to the lower A-arm with a cap screw and new lock nut. Tighten to 20 ft-lb.
9. Secure the boot guard to the lower A-arm with the two cap screws. Tighten securely.
10. Install the wheel and tighten to 80 ft-lb.
11. Remove the vehicle from the support stand.

Wheels and Tires

TIRE SIZE

⚠ WARNING

Use only Arctic Cat approved tires when replacing tires. Failure to do so could result in unstable vehicle operation.

This vehicle is equipped with low-pressure tubeless tires of the size and type listed in Section 1. Do not under any circumstances substitute tires of a different type or size.

⚠ WARNING

Always use the size and type of tires specified. Always maintain proper tire inflation pressure.

⚠ WARNING

Do not mix tire tread patterns. Use the same pattern type on front and rear. Failure to heed warning could cause poor handling qualities of the vehicle and could cause excessive drive train damage not covered by warranty.

TIRE INFLATION PRESSURE

Front and rear tire inflation pressure should be 1.41 kg/cm² (20 psi).

REMOVING

1. Secure the vehicle on a support stand to elevate the wheels.

WARNING

Make sure the vehicle is solidly supported on the support stand to avoid injury.

2. Remove the nuts securing the wheels; then remove the wheels.

CLEANING AND INSPECTING

■**NOTE:** Whenever a part is worn excessively, cracked, or damaged in any way, replacement is necessary.

1. Clean the wheels and hubs with parts-cleaning solvent.
2. Clean the tires with soap and water.
3. Inspect each wheel for cracks, dents, or bends.
4. Inspect each tire for cuts, wear, missing lugs, and leaks.

INSTALLING

1. Install each wheel on its hub and secure with the existing hardware.
2. Tighten to 80 ft-lb.

CHECKING/INFLATING

1. Using an air pressure gauge, measure the air pressure in each tire. Adjust the air pressure as necessary to meet the recommended inflation pressure.
2. Inspect the tires for damage, wear, or punctures.

WARNING

Do not operate the vehicle if tire damage exists.

■**NOTE:** If repair is needed, follow the instructions found on the tire repair kit or remove the wheel and have it repaired professionally.

■**NOTE:** Be sure all tires are the specified size and have identical tread pattern.

Troubleshooting

Problem: Suspension too soft	
Condition	Remedy
<ol style="list-style-type: none"> 1. Spring preload incorrect 2. Spring(s) weak 3. Shock absorber damaged 	<ol style="list-style-type: none"> 1. Adjust preload 2. Replace spring(s) 3. Replace shock absorber
Problem: Suspension too stiff	
Condition	Remedy
<ol style="list-style-type: none"> 1. Spring preload incorrect 2. A-arm-related bushings worn 	<ol style="list-style-type: none"> 1. Adjust preload 2. Replace bushing
Problem: Suspension noisy	
Condition	Remedy
<ol style="list-style-type: none"> 1. Cap screws (suspension system) loose 2. A-arm-related bushings worn 	<ol style="list-style-type: none"> 1. Tighten cap screws 2. Replace bushings
Problem: Vehicle pulling or steering erratic	
Condition	Remedy
<ol style="list-style-type: none"> 1. Vehicle steering is erratic on dry, level surface 2. Vehicle pulls left or right on dry, level surface 	<ol style="list-style-type: none"> 1. Check front wheel alignment and adjust if necessary (see Section 8) 2. Check air pressure in tires and adjust to specifications

SECTION 8 - STEERING/FRAME

TABLE OF CONTENTS

Steering/Frame.....	8-2
Electronic Power Steering (EPS).....	8-2
Steering Assembly	8-5
Steering Wheel.....	8-6
Upper Steering Shaft.....	8-6
Intermediate Steering Shaft Assembly.....	8-7
Steering Knuckles	8-8
Checking/Adjusting Front Wheel Alignment	8-10
Front Bumper Assembly	8-11
Hood.....	8-11
Fenders	8-12
Floor	8-12
Dashboard.....	8-13
Belly Panel	8-13
Exhaust System	8-13
Cargo Box	8-14
Taillight Assembly.....	8-14
Seat.....	8-15
Troubleshooting	8-15

Steering/Frame

■NOTE: Critical torque specifications are located in Section 1.

The following steering components should be inspected periodically to ensure safe and proper operation.

- A. Steering wheel secure.
- B. Steering has equal and complete full-left and full-right capability.
- C. Steering sector mounting bolts tight.
- D. Ball joints not worn, cracked, or damaged.
- E. Tie rods not bent or cracked.
- F. Knuckles not worn, cracked, or damaged.
- G. Cotter pins not damaged or missing.
- H. Steering wheel tilt locks securely.

The frame and welds should be checked periodically for damage, bends, cracks, deterioration, broken components, and missing components.

Electronic Power Steering (EPS)

REMOVING EPS ASSEMBLY

■NOTE: Thoroughly troubleshoot the EPS system prior to replacing the EPS assembly (see Section 5) as there are several possible external causes for system failure.

1. Support the vehicle on appropriate stands or a lift; then remove the left front wheel and left front shock absorber.
2. Remove the front storage box; then disconnect the two electrical connectors from the EPS assembly.



PR759A

3. Remove the cap screw securing the intermediate shaft yoke to the EPS assembly input shaft.

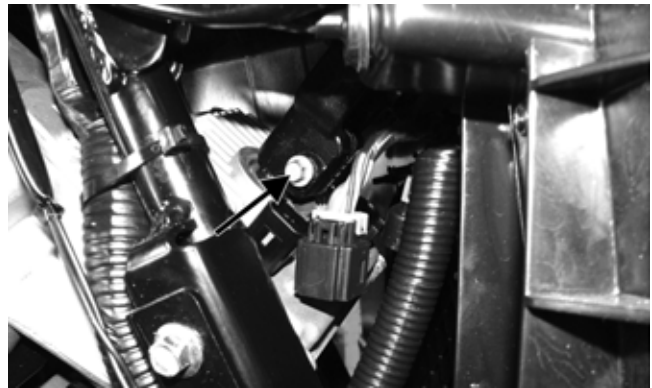

PR760A

4. Remove the steering wheel; then remove the steering wheel boot support.



PR762A

5. Remove the sheet metal screws securing the dash assembly to the frame; then disconnect the gauge plug and the dash harness. Remove the dash assembly.
6. Remove the four cap screws and nuts securing the steering shaft housing to the steering support; then remove the cap screw securing the intermediate shaft yoke to the steering shaft.



PR764A



PR765A

7. Remove the steering shaft housing and shaft from the steering support and intermediate shaft; then remove the intermediate shaft from the EPS input shaft.
8. Remove four cap screws securing the EPS assembly to the frame; then remove the cap screw securing the rack coupler to the EPS output shaft.

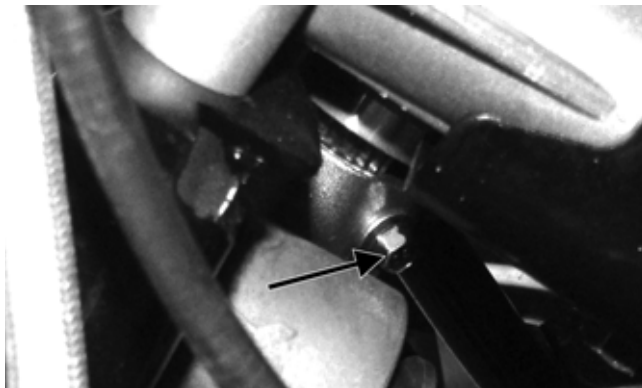

PR761A

■NOTE: No repairs are authorized on the EPS assembly and it must be replaced as a complete assembly.

INSTALLING EPS ASSEMBLY

1. Align the slot in the rack coupler to the notch in the frame (front wheels centered).



PR766A

2. Rotate the EPS shaft to align the index (flattened) spline with the slot in the rack coupler.

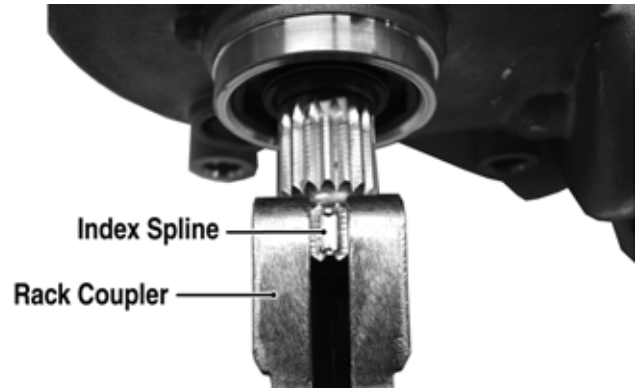

PR776A

■NOTE: Alignment need only be approximate as final alignment is not possible until the EPS is engaged with the coupler.

3. Install the EPS assembly into the coupler turning the EPS shaft slightly to align the index spline; then seat the EPS firmly onto the frame.
4. Install four cap screws securing the EPS assembly to the frame and tighten to 35 ft-lb.
5. Install the cap screw in the EPS to rack coupler and tighten to 11 ft-lb.
6. Connect the two electrical connectors; then align the slot in the intermediate steering shaft coupler to the index (flattened) spline on the EPS input shaft and install. Install but do not tighten the cap screw.



PR759B

7. Install the steering shaft housing with steering shaft connecting the steering shaft and intermediate shaft first; then slide the housing into place on the steering support.
8. Secure the steering shaft housing to the frame with four cap screws and nuts. Tighten the 6 mm nuts to 8 ft-lb and the 8 mm nuts to 20 ft-lb.

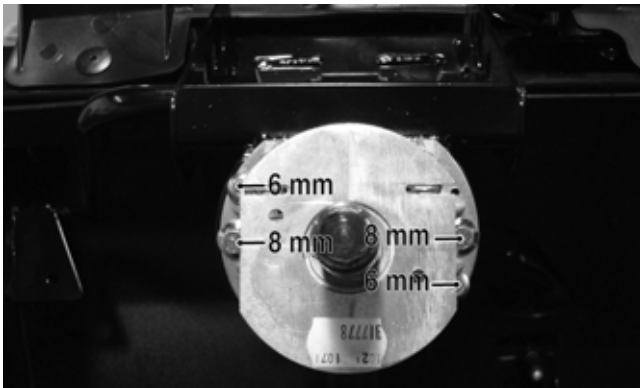

PR764B

9. Install the cap screw in the intermediate shaft coupler and tighten to 31 ft-lb; then tighten the cap screw (from step 6) to 11 ft-lb.



PR765A

10. Install the front storage box; then install the dash and connect the two electrical connectors. Secure with sheet metal screws and tighten securely. Do not over-tighten.
11. Install the steering housing boot; then install the boot support and secure with two machine screws.
12. Install the steering wheel; then apply a drop of red Loctite #271 to the threads of the castle nut. Secure the steering wheel and tighten to 25 ft-lb. Install the lock clip and cover.

REMOVING TIE RODS

1. Remove the steering rack assembly (see Steering Assembly in this section).
2. Support the steering rack assembly in a suitable holding fixture or bench vise; then cut the securing band and slide the boot toward the outer tie rod end.
3. Using a punch or chisel, bend the lock washer away from the flats on the tie rod joint.



PR780

4. Using an appropriate crow-foot and backing wrench, remove the tie rod assembly.

■NOTE: Tie rods come as a complete assembly. No further disassembly is required.

5. Remove and discard the lock washer.

INSTALLING TIE RODS

1. Remove the tie rod end and lock nut from the tie rod; then install the tie rod boot onto the tie rod.
2. Install the tie rod lock nut and tie rod end.
3. Coat the tie rod joint threads with red Loctite #271; then with a new lock washer, thread the tie rod into the rack.

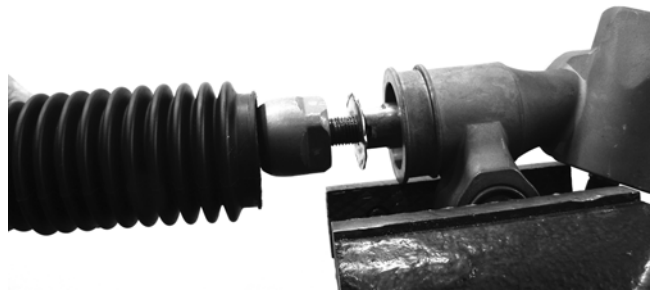

PR784

4. While holding the rack shaft with a wrench, tighten the tie rod joint to 37 ft-lb using an appropriate crow-foot.



PR781

■NOTE: Always attach the crow-foot to the torque wrench with the open end 90° to the torque wrench handle to ensure accurate torque application.

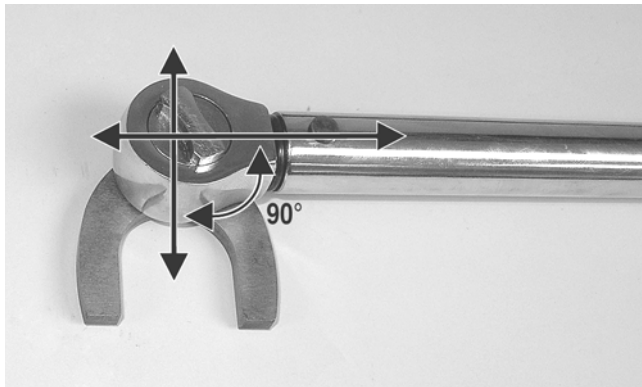

PR528A

5. Install the boot onto the rack and secure with the nylon tie.
6. Center the rack in the steering rack assembly and align the white paint line on the pinion with the mark on the rack housing.



PR785A

Steering Assembly

REMOVING

■NOTE: The EPS assembly must be removed prior to removing the steering assembly (see Electronic Power Steering (EPS) in this section).

1. Remove the EPS assembly; then remove the right front wheel.
2. Remove the cotter pins and nuts securing the tie rod ends to the knuckles; then remove the tie rod ends from the knuckles.

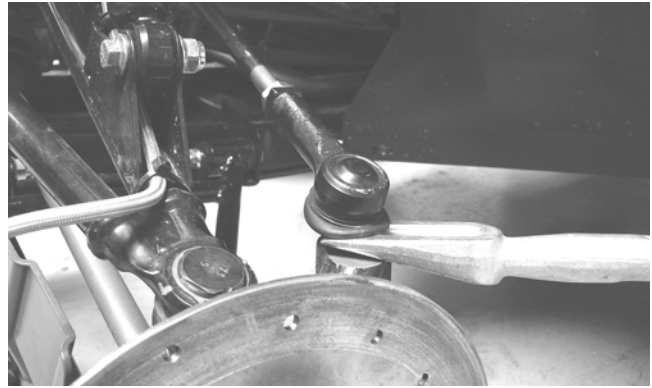

PR301

3. Remove the EPS cradle bracket; then remove the cap screws securing the steering rack assembly to the rack bracket and remove from the left side.

INSPECTING

■NOTE: Whenever a part is worn excessively, cracked, or damaged in any way, replacement is necessary.

1. Inspect the tie rod ends for damaged threads, torn boots, or excessive wear.
2. Inspect the tie rods for bends or deformation.
3. Inspect the rack and pinion-to-tie rod boots for tears or deterioration.



PR785

4. Check boot clamps for security.
5. Check that the steering assembly operates smoothly with no binding from full-left to full-right position.
6. Inspect for grease seepage from the steering assembly.

■NOTE: The steering assembly (rack and pinion) is not repairable and must be replaced as an assembly; however, the tie rods and boots are replaceable.

INSTALLING

1. From the left side, install the steering assembly to the frame assembly and secure with two cap screws. Tighten to 35 ft-lb.

2. Install the EPS cradle bracket and secure with four cap screws. Do not tighten the cap screws at this time.

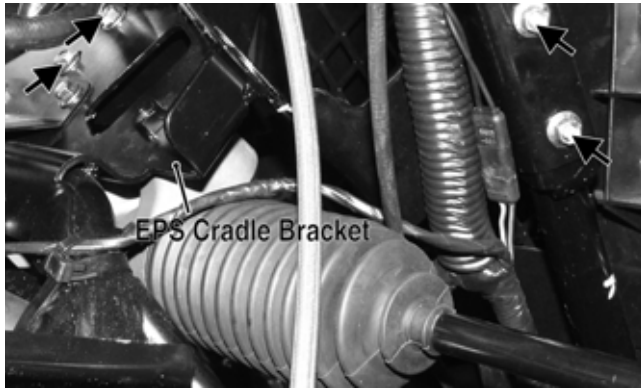

PR773A

3. Place the tie rod ends into the knuckles and secure with the castle nuts (coated with red Loctite #271). Tighten to 30 ft-lb; then install new cotter pins.

■NOTE: If the slots in the castle nut are not aligned with the hole in the tie rod end, tighten until the cotter pin can be installed.

4. Install the EPS assembly (see Installing EPS Assembly sub-section in this section); then tighten the cap screws (from step 2) to 20 ft-lb.
5. Install the wheel and tighten to 80 ft-lb.

Steering Wheel

REMOVING

1. Remove the steering wheel cover; then match mark the steering shaft and steering wheel.

■NOTE: Any time steering components are disassembled, all connecting components should be marked for proper alignment during assembling.

2. Remove the lock clip from the steering shaft; then remove the nut securing the steering wheel and remove the steering wheel.

INSPECTING

1. Inspect the steering wheel for cracks, missing padding, or broken spokes.
2. Inspect the splines for wear.
3. Check that the steering wheel is not bent.

INSTALLING

1. Install the steering wheel aligning the two match marks; then apply a drop of red Loctite #271 to the threads of the nut and secure the steering wheel. Tighten to 25 ft-lb.

■NOTE: If a new steering wheel is being installed, mark the wheel as close as possible to the old wheel mark; then check for proper positioning with the front wheels straight forward.

2. Install the lock clip on the steering shaft.

■NOTE: If the hole in the steering shaft does not align with the slots in the castle nut, tighten the nut slightly until the next slot aligns with the hole.



HDX131A

Upper Steering Shaft

REMOVING

1. Remove the dashboard (see Dashboard in this section).
2. Remove the four cap screws and nuts securing the steering shaft housing to the steering support; then remove the cap screw securing the intermediate shaft yoke to the steering shaft.



PR764A



PR765A

3. Remove the steering shaft housing and shaft from the steering support and intermediate shaft; then remove the intermediate shaft from the EPS input shaft.

■NOTE: Any time steering components are disassembled, all connecting components should be marked for proper alignment during assembling.

INSPECTING

1. Inspect the steering wheel shaft for excessive wear.
2. Check for worn splines, cracks, or damaged threads.
3. Roll the steering wheel shaft on a flat surface to check for bends.
4. Inspect the nylon bushings in the steering shaft housing for cracking or excessive wear.

INSTALLING

1. Install the steering shaft housing with steering shaft connecting the steering shaft and intermediate shaft first; then slide the housing into place on the steering support.
2. Secure the steering shaft housing to the frame with four cap screws and nuts. Tighten the 6 mm nuts to 8 ft-lb and the 8 mm nuts to 20 ft-lb.

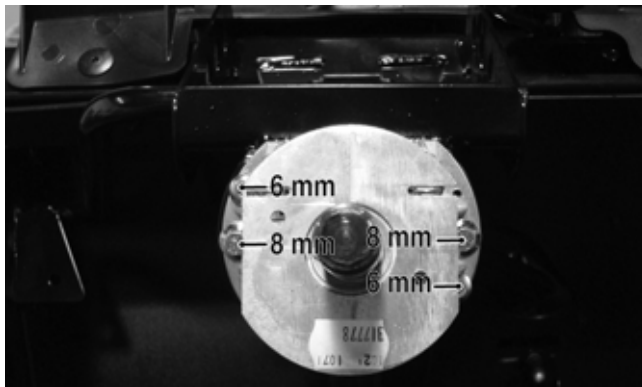

PR764B

3. Install the cap screw in the intermediate shaft coupler and tighten to 31 ft-lb.



PR765A

Intermediate Steering Shaft Assembly

AT THIS POINT

Before beginning this procedure, the upper steering shaft must be removed (see Upper Steering Shaft in this section).

REMOVING

With the upper steering shaft removed, remove the cap screw from the intermediate shaft coupler and remove the shaft from the EPS and vehicle.

INSPECTING

■NOTE: The lower steering shaft assembly is not repairable or rebuildable. If any damage or excessive wear is detected, the assembly must be replaced.

1. Inspect the joints for excessive wear or looseness.
2. Inspect welds.

INSTALLING

1. Place the steering shaft assembly into position through the opening in the splash panel; then align the slot in the intermediate steering shaft coupler to the index (flattened) spline on the EPS input shaft and install. Install but do not tighten the cap screw.



PR759B

2. Install the steering shaft housing with steering shaft connecting the steering shaft and intermediate shaft first; then slide the housing into place on the steering support.
3. Secure the steering shaft housing to the frame with four cap screws and nuts. Tighten the 6 mm nuts to 8 ft-lb and the 8 mm nuts to 20 ft-lb.

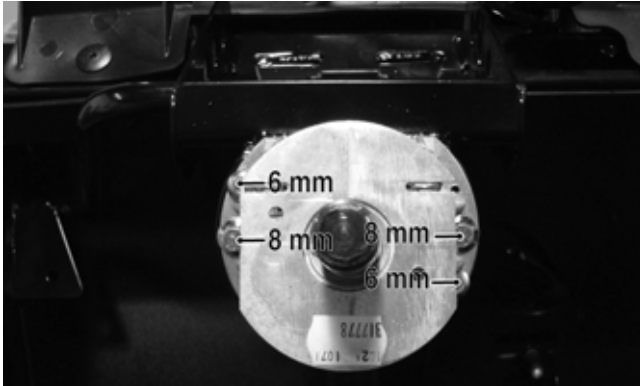

PR764B

4. Install the cap screw in the intermediate shaft coupler and tighten to 31 ft-lb; then tighten the cap screw (from step 1) to 11 ft-lb.



PR765A

5. Install the dash and connect the two electrical connectors. Secure with sheet metal screws and tighten securely. Do not over-tighten.
6. Install the steering housing boot; then install the boot support and secure with two machine screws.
7. Install the steering wheel; then apply a drop of red Loctite #271 to the threads of the castle nut. Secure the steering wheel and tighten to 25 ft-lb. Install the lock clip and cover.

Steering Knuckles

REMOVING AND DISASSEMBLING

1. Secure the vehicle on a support stand to elevate the wheel; then remove the wheel.

⚠ WARNING

Make sure the vehicle is solidly supported on the support stand to avoid injury.

2. Remove the cotter pin from the axle.
3. Remove the nut securing the hub.
4. Remove the brake caliper.
5. Remove the hub assembly.
6. Remove the cotter pin from the tie rod end and remove the tie rod end from the knuckle.
7. Remove the two cap screws securing the ball joints in the knuckle.

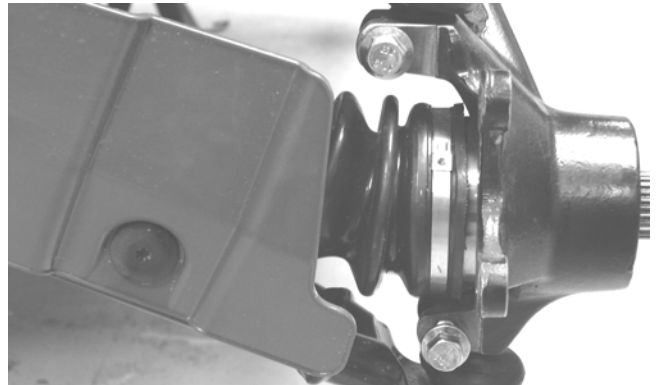

PR193

8. Tap the ball joint end out of the knuckle; then remove the knuckle.
9. Remove the snap ring securing the bearing in the knuckle; then press the bearing out of the knuckle.



PR289

CLEANING AND INSPECTING

■ **NOTE:** Whenever a part is worn excessively, cracked, or damaged in any way, replacement is necessary.

1. Clean all knuckle components.
2. Inspect the bearing for pits, scoring, rusting, or premature wear.
3. Inspect the knuckle for cracks, breaks, or galling of the bearing surface.

ASSEMBLING AND INSTALLING

1. Using a suitable press and driver, press the bearing into the knuckle until firmly seated; then install the snap ring.

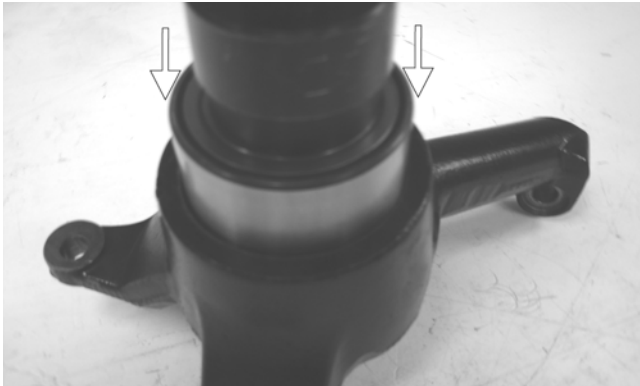

PR292A

■NOTE: During assembling, new cotter pins should be installed.

4. Apply a small amount of grease to the hub splines.

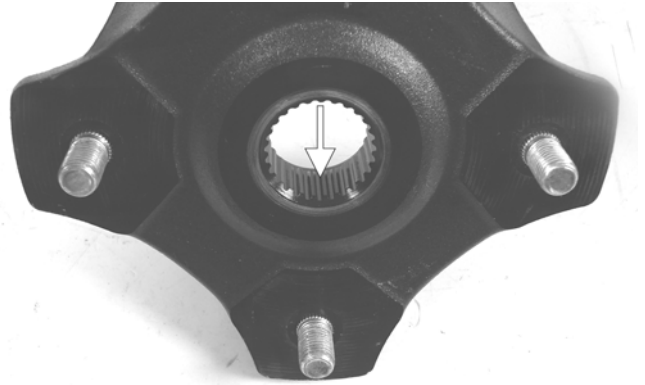

PR290A



PR289

2. Install the knuckle to the upper and lower ball joints and secure with the two cap screws. Tighten to 35 ft-lb.

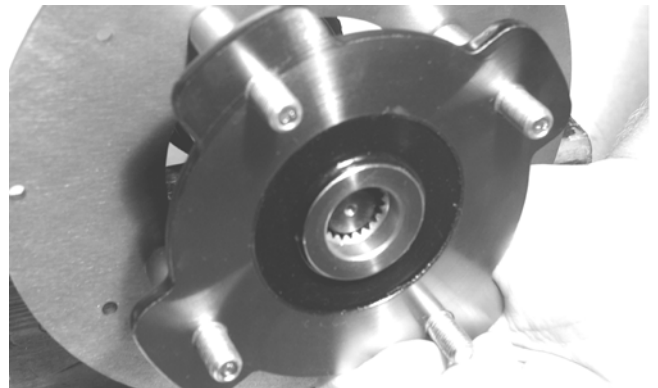

CD009

6. Secure the hub assembly with the nut. Tighten to 200 ft-lb.

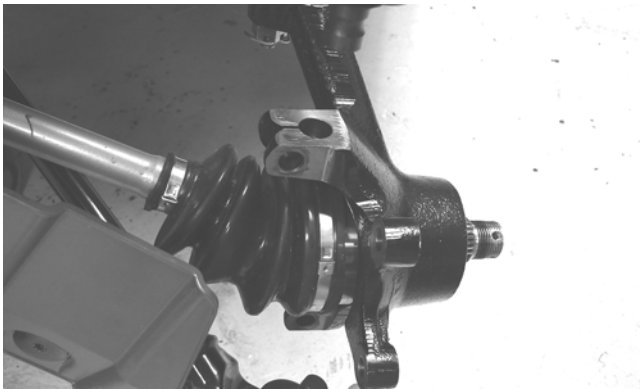

PR202

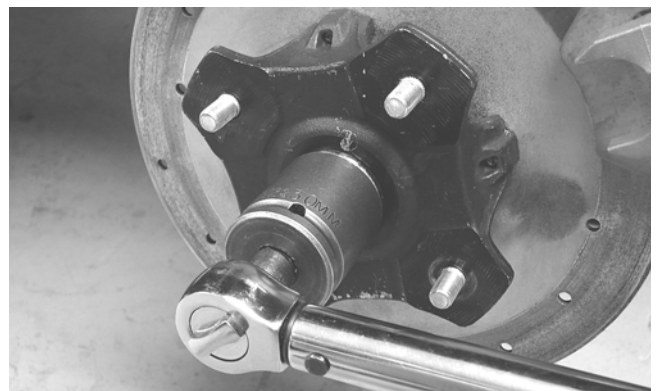

PR256

7. Install a new cotter pin and secure by spreading as shown.



PR203

3. Install the tie rod end and secure with the nut (coated with red Loctite #271). Tighten to 30 ft-lb; then install a new cotter pin and spread the pin.

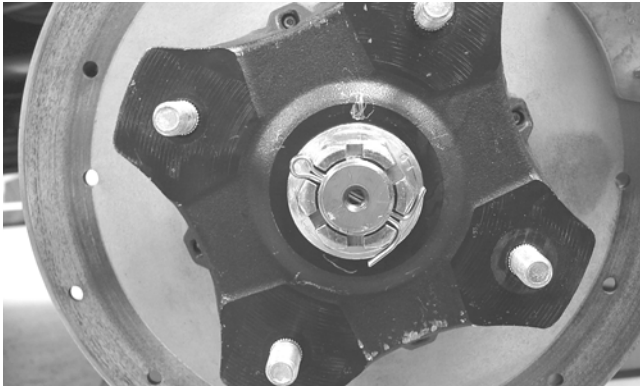

PR260

■NOTE: If the hole in the axle shaft does not align with the slots in the castle nut, tighten the nut until the hole and slots align.

- Secure the brake caliper to the knuckle with the two new “patch-lock” cap screws. Tighten to 20 ft-lb.

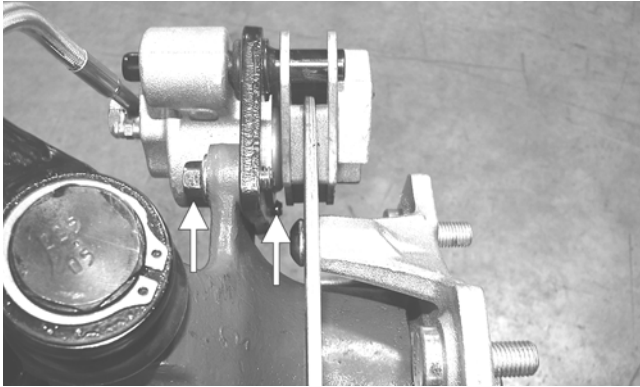

PR377B

- Install the wheel; then using a crisscross pattern, tighten to 80 ft-lb.

- Remove the vehicle from the support stand.

Checking/Adjusting Front Wheel Alignment

■NOTE: All measurements and adjustments must be made with the vehicle unloaded.

Mark the center-line of the front tires at the front and rear of the tire; then using a tape measure, measure and record the distance between the marks at the front and rear. The front measurement should be 6-12 mm (1/4-1/2 in.) greater than the rear measurement (toe-out).

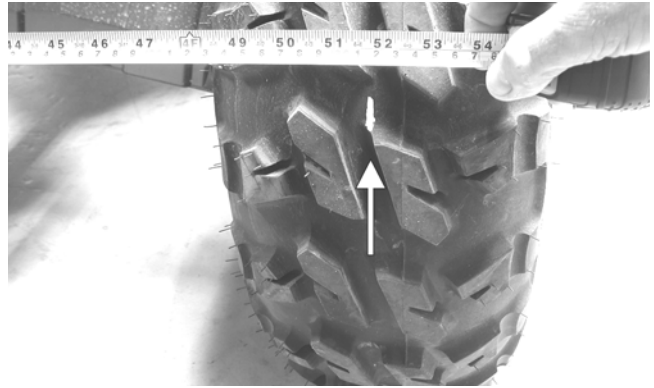

PR087A

To adjust the wheel alignment, use the following procedure.

- Center the steering wheel; then using an open-end wrench to hold the tie rod ends, loosen the right-side and left-side jam nuts.



HDX098B

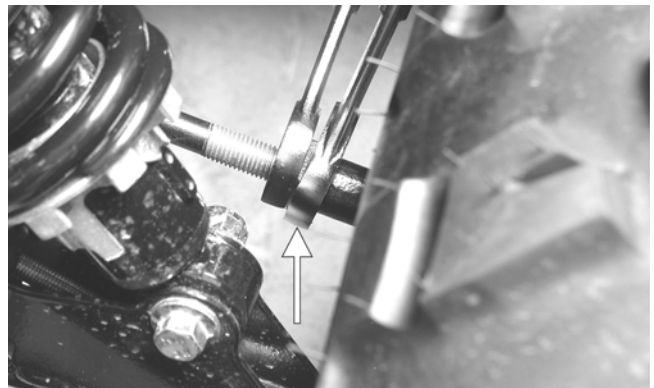

PR085A

CAUTION

Always use a wrench to hold the tie rod ends when loosening or tightening the jam nuts or damage to the boots could occur.

- Turn the left-side and right-side tie rods in equal increments to achieve the proper toe-out; then tighten the jam nuts securely.

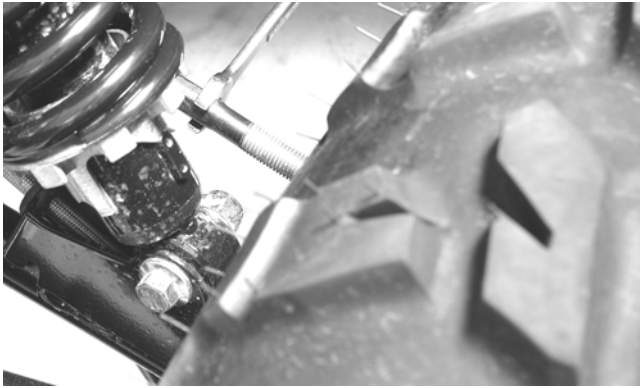

PR086

Front Bumper Assembly

REMOVING

Remove four cap screws and nuts. Account for four lock washers and eight flat washers.

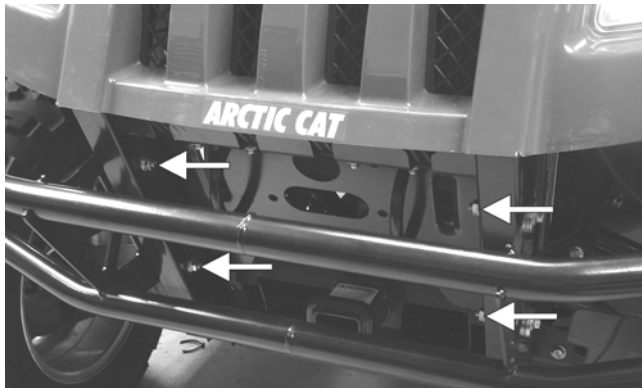

PR327A

CLEANING AND INSPECTING

■NOTE: Whenever a part is worn excessively, cracked, or damaged in any way, replacement is necessary.

1. Clean all bumper components with hot, soapy water.
2. Inspect all welds for cracking or bending.

INSTALLING

Place the bumper assembly into position on the frame; then secure with the four cap screws and nuts making sure the flat washers and lock washers are properly positioned. Tighten securely.

Hood

REMOVING

1. Open the hood; then disconnect the four headlight connectors and remove two nylon ties.

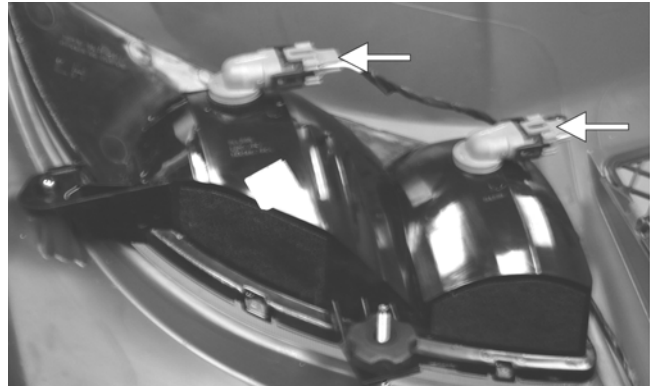

PR328A

2. Loosen but do not remove the four cap screws and flange nuts securing the hood hinge to the frame; then lower the hood.

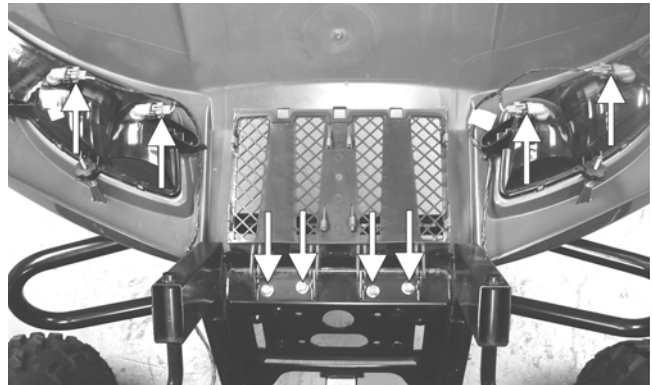

PR332A

3. Finish removing the cap screws and flange nuts (from step 2); then remove the hood assembly.

CLEANING AND INSPECTING

■NOTE: Whenever a part is worn excessively, cracked, or damaged in any way, replacement is necessary.

1. Clean all hood components with soap and water.
2. Inspect the hood for cracks and/or loose fasteners.
3. Inspect for any missing decals.

INSTALLING

1. Place the hood into position on the vehicle; then install the two outside cap screws and flange nuts. Finger-tighten only at this time.
2. Open the hood; then install the remaining two cap screws and flange nuts. Tighten all four securely.



PR332

3. Connect the four headlight connectors; then secure the wires with two new nylon ties.

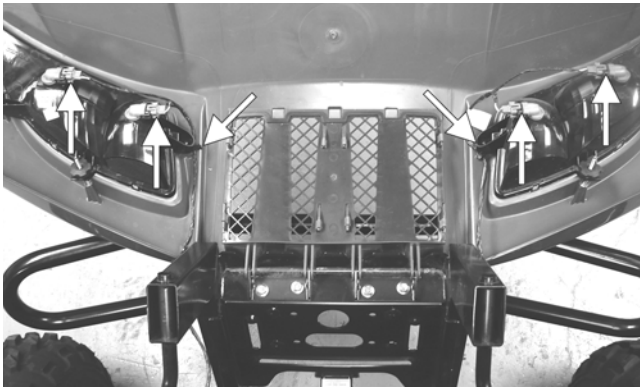

PR332B

Fenders

REMOVING

Remove three torx-head screws securing each fender to the frame. Account for a stiffener bracket on the front fenders.

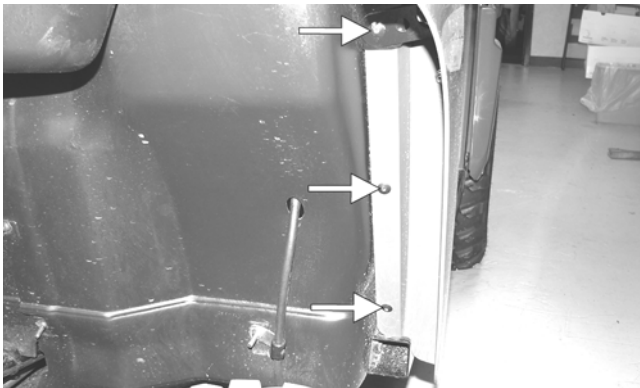

PR311A

INSTALLING

Place the appropriate fender into position and secure with existing hardware.

Floor

REMOVING

1. Remove the seat, seat back, and seat base.
2. Remove the self-tapping screws securing the side foot restraints.
3. Remove the center floorboard.

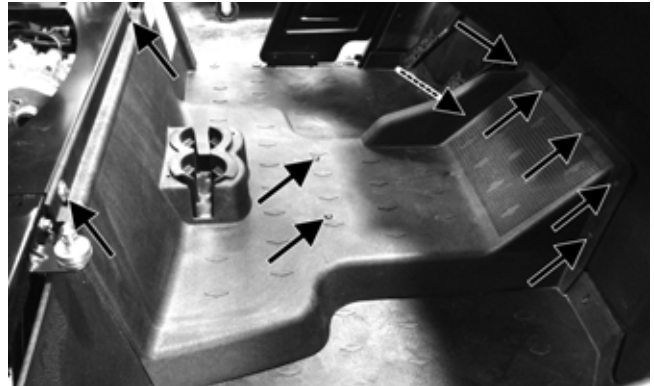

HDX132A

4. While pulling forward on the upper-rear of the floor, lift the rear part of the floor above the seat locating stud.

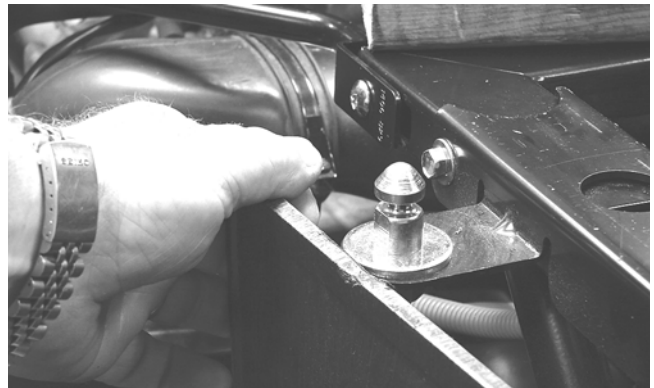

PR163

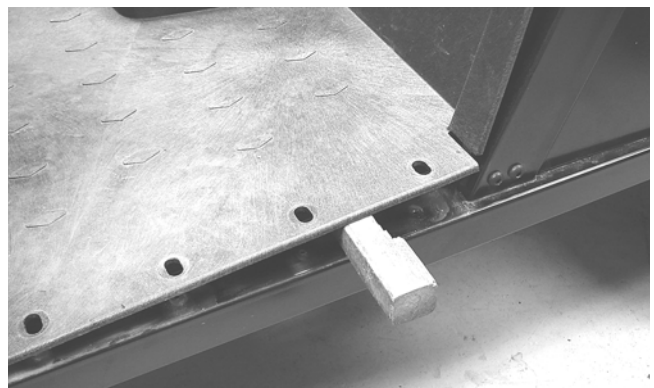

PR164

■ **NOTE:** To aid in removing, insert a small wood block to hold in position.

- From the opposite side of the vehicle repeat step 3; then lift the rear of the floor up and lift the floor out of the vehicle.

CLEANING AND INSPECTING

■NOTE: Whenever a part is worn excessively, cracked, or damaged in any way, replacement is necessary.

- Clean the floor with soap and water.
- Inspect the floor for cracks or holes.

INSTALLING

- Place the front of the floor into position in the vehicle first; then lower the rear and push past the seat locating studs.
- Secure the floor with the cap screws and self-tappings screws.
- Install the center floorboard; then install the seat base, seat back, and seat.

Dashboard

REMOVING

- Remove the steering wheel and steering shaft boot.
- Remove two machine screws securing the steering shaft boot support to the steering support and remove the boot support.



PR762A

- Remove the six sheet metal and three machine screws securing the dash assembly to the frame; then remove the shift lever grip and locking nut.
- Disconnect the gauge plug, dash harness, and park/seat belt indicator light connector and remove the dash assembly.
- Slide the dash assembly rearward and off the steering shaft and shift lever assemblies.

INSTALLING

- Place the dash into position and connect the park/seat belt indicator light, dash harness, and gauge connector.
- Secure the dash with the six sheet metal and three machine screws. Do not over-tighten.
- Install the steering shaft boot support and secure with machine screws; then install the steering shaft boot and steering wheel. Apply a drop of red Loctite #271 to the steering shaft; then tighten the steering wheel nut to 25 ft-lb and install the lock clip.
- Install the steering wheel cover.
- Check shifter/shift cable adjustment (see Shift Lever - Adjusting Shift Cable in section 2).

Belly Panel

REMOVING

- Remove the body screws securing the belly panel to the underside of the frame.
- Remove the belly panel.

INSTALLING

- Place the belly panel into position on the underside of the frame.
- Install the body screws. Tighten securely.

Exhaust System

REMOVING MUFFLER

- Remove the two exhaust springs at the muffler/exhaust pipe juncture.

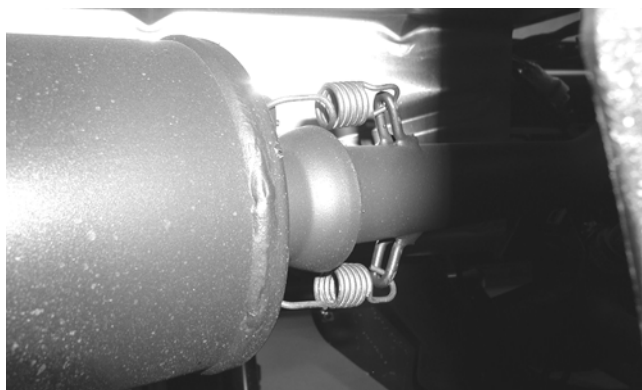

PR131

- Slide the muffler assembly clear of the holder pins.

INSPECTING MUFFLER

■NOTE: Whenever a part is worn excessively, cracked, or damaged in any way, replacement is necessary.

1. Inspect muffler externally for cracks, holes, and dents.
2. Inspect the muffler internally by shaking the muffler back and forth and listening for rattles or loose debris inside the muffler.

■NOTE: For additional details on cleaning the muffler/spark arrester, see Section 2.

INSTALLING MUFFLER

1. Place the muffler onto the holder pins and slide into position.
2. Secure the muffler to the exhaust pipe with the two exhaust springs.

Cargo Box

REMOVING

1. Raise the cargo box; then remove the cap screw and nut securing the lower lift support to the frame. Account for the washer. The cargo box will tilt fully rearward.

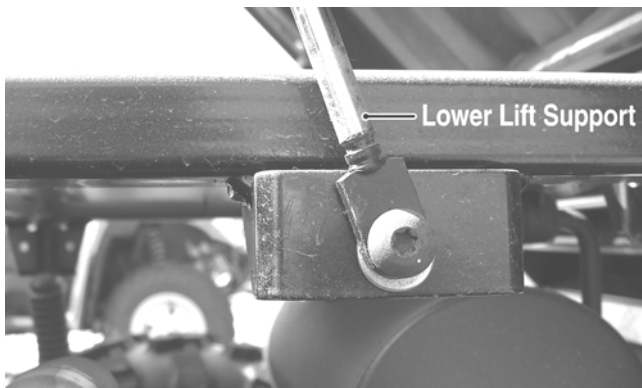

PR473A

2. Loosen but do not remove the four shoulder cap screws securing the pivot housings to the cargo box.



PR335

3. Lower the cargo box; then remove the four cap screws (from step 2).
4. With the help of an assistant or an adequate lift, remove the cargo box from the vehicle. Account for four pivot housings.

CLEANING AND INSPECTING

■NOTE: Whenever a part is worn excessively, cracked, or damaged in any way, replacement is necessary.

1. Clean all cargo box components with soap and water.
2. Inspect the cargo box for cracks, tears, and loose hardware.
3. Inspect the welds of the cargo box frame for cracking or bending.
4. Inspect the cargo box gate latches for smooth operation.

INSTALLING

1. With the help of an assistant or an adequate lift, set the cargo box into position on the frame; then position the two upper pivot housings between the cargo box and frame. Lightly grease the pivot housings.
2. Align the holes in the upper pivot housings with the holes in the cargo box; then install the lower pivot housings and secure with the four shoulder cap screws. Tighten to 20 ft-lb.
3. Raise the cargo box; then connect the lift support to the frame, install the cap screw and nut, and tighten the nut securely.
4. Lower the cargo box and lock into position.

Taillight Assembly

REMOVING

1. Remove two torx-head screws securing the taillight assembly to the rear ROPS tube; then rotate the taillight assembly left or right to allow the connector to clear the access opening.

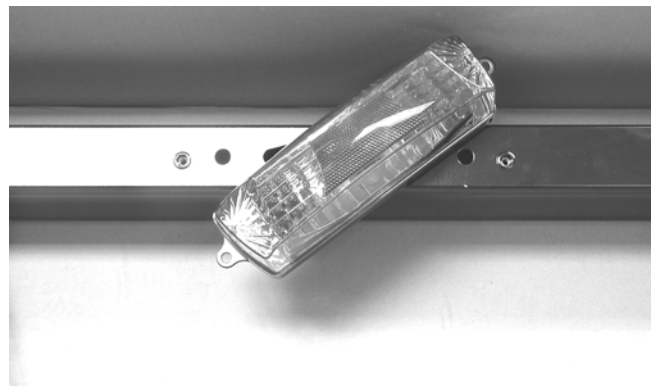

PR056

2. Disconnect the three-prong connector from the bulb socket and remove the taillight assembly.

INSPECTING

■ **NOTE: Whenever a part is worn excessively, cracked, or damaged in any way, replacement is necessary.**

1. Inspect wiring harness, three-prong connector, lens, base, cap screws, and socket for damage.
2. Inspect all wires for corroding, pinching, and cracking.
3. Inspect the bulb for wattage, voltage, and proper operation.

INSTALLING

1. Connect the three-prong connector to the bulb socket; then place the taillight assembly into position on the rear ROPS tube.
2. Install the two torx-head screws and tighten securely.

Seat

REMOVING/INSTALLING

1. To remove the seat, raise the front of the seat and slide it forward.
2. To install the seat, slide the rear of the seat into the seat retainers and push down firmly on the front of seat.

Troubleshooting

Problem: Handling too heavy or stiff

Condition	Remedy
<ol style="list-style-type: none"> 1. Front wheel alignment incorrect 2. Lubrication inadequate 3. Tire inflation pressure incorrect 4. Tie rod ends seizing 5. Linkage connections seizing 	<ol style="list-style-type: none"> 1. Adjust alignment 2. Lubricate appropriate components 3. Adjust pressure 4. Replace tie rod ends 5. Repair - replace connections

Problem: Steering oscillation

Condition	Remedy
<ol style="list-style-type: none"> 1. Tires inflated unequally 2. Wheel(s) wobbly 3. Wheel hub cap screw(s) loose - missing 4. Wheel hub bearing worn - damaged 5. Tie rod ends worn - loose 6. Tires defective - incorrect 7. A-arm bushings damaged 8. Bolts - nuts (frame) loose 	<ol style="list-style-type: none"> 1. Adjust pressure 2. Replace wheel(s) 3. Tighten - replace cap screws 4. Replace bearing 5. Replace - tighten tie rod ends 6. Replace tires 7. Replace bushings 8. Tighten bolts - nuts

Problem: Steering pulling to one side

Condition	Remedy
<ol style="list-style-type: none"> 1. Tires inflated unequally 2. Front wheel alignment incorrect 3. Wheel hub bearings worn - broken 4. Frame distorted 5. Shock absorber defective 	<ol style="list-style-type: none"> 1. Adjust pressure 2. Adjust alignment 3. Replace bearings 4. Repair - replace frame 5. Replace shock absorber

Problem: Steering impaired

Condition	Remedy
<ol style="list-style-type: none"> 1. Tire pressure too high 2. Steering linkage connections worn 3. Cap screws (suspension system) loose 	<ol style="list-style-type: none"> 1. Adjust pressure 2. Replace connections 3. Tighten cap screws

Problem: Tire wear rapid or uneven	
Condition	Remedy
<ol style="list-style-type: none"> 1. Wheel hub bearings worn - loose 2. Front wheel alignment incorrect 	<ol style="list-style-type: none"> 1. Replace bearings 2. Adjust alignment
Problem: Steering noise	
Condition	Remedy
<ol style="list-style-type: none"> 1. Caps screws - nuts loose 2. Wheel hub bearings broken - damaged 3. Lubrication inadequate 	<ol style="list-style-type: none"> 1. Tighten cap screws - nuts 2. Replace bearings 3. Lubricate appropriate components
Problem: Rear wheel oscillation	
Condition	Remedy
<ol style="list-style-type: none"> 1. Rear wheel hub bearings worn - loose 2. Tires defective - incorrect 3. Wheel rim distorted 4. Wheel hub cap screws loose 5. Parking brake adjusted incorrectly 6. Rear suspension arm-related bushing worn 7. Rear shock absorber damaged 8. Rear suspension arm nut loose 	<ol style="list-style-type: none"> 1. Replace bearings 2. Replace tires 3. Replace rim 4. Tighten cap screws 5. Adjust parking brake 6. Replace bushing 7. Replace shock absorber 8. Tighten nut

SECTION 9 - CONTROLS/INDICATORS

TABLE OF CONTENTS

Accelerator Pedal 9-2
Shift Lever 9-2
Shift Cable..... 9-2
Speedometer/Tachometer/LCD/Indicator Lights 9-3

Accelerator Pedal

REMOVING

Dislodge the throttle cable holding grommet from the actuator arm; then remove two torx-head screws and nuts securing the accelerator pedal assembly to the splash panel and remove the accelerator pedal.



PR709

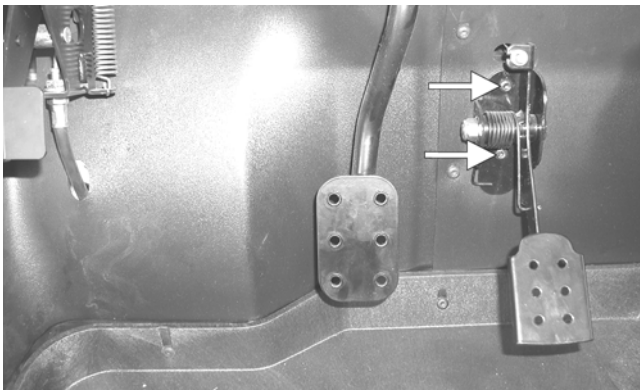

PR342C

INSTALLING

Align the mounting holes with the holes in the splash panel and secure with the two torx-head screws and nuts; then snap the throttle cable holding grommet into the actuator arm.

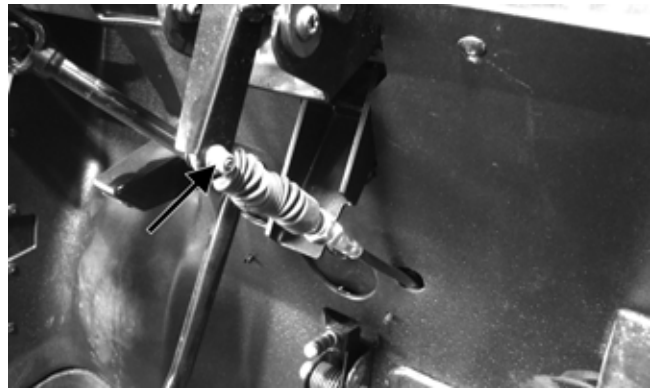

HDX166A

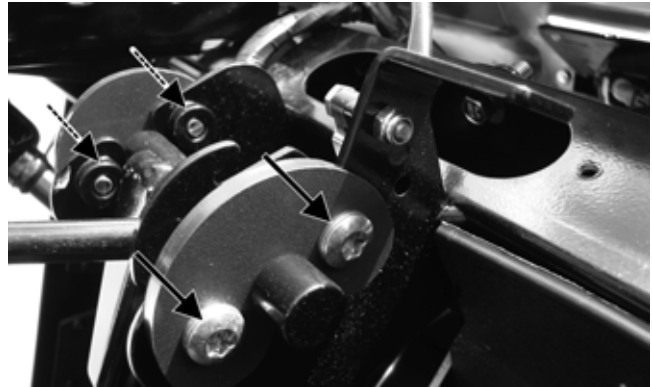

HDX168A

INSTALLING

1. Install the shift axle supports onto the shift lever; then secure the axle supports to the frame with four cap screws and tighten to 48 in.-lb.

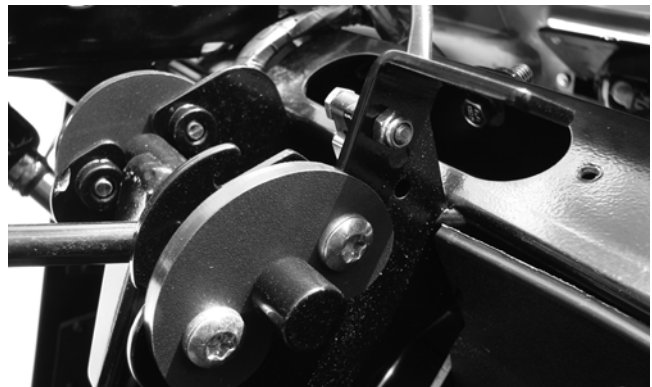

HDX168

2. Secure the shift cable end to the shift lever arm with the cap screw and nut. Tighten to 8 ft-lb.

Shift Lever

REMOVING

1. Remove the dashboard (see Dashboard in Section 8).
2. Remove the nut securing the shift cable to the shift arm; then remove the four cap screws securing the shift axle supports to the frame and remove the shift lever.

Shift Cable

REMOVING

1. Remove the dashboard (see Dashboard, Removing in section 8).

- Remove the nut securing the shift cable to the shift arm; then loosen the upper adjuster nut on the shift cable and remove the shift cable from the shifter assembly.



HDX166A

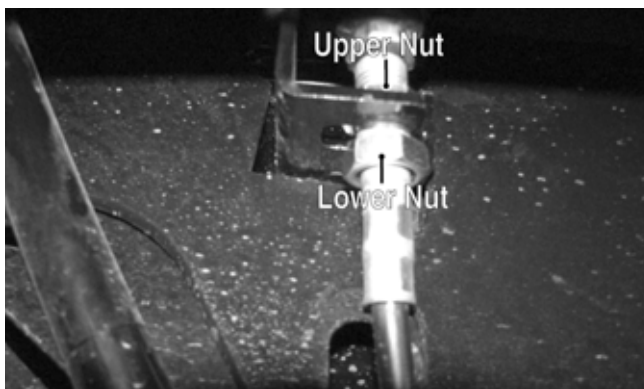

HDX178A

- Tilt the cargo box back and remove the E-clip from the shift arm on the transmission; then loosen the adjuster nut on the shift cable housing and remove the shift cable from the transmission.

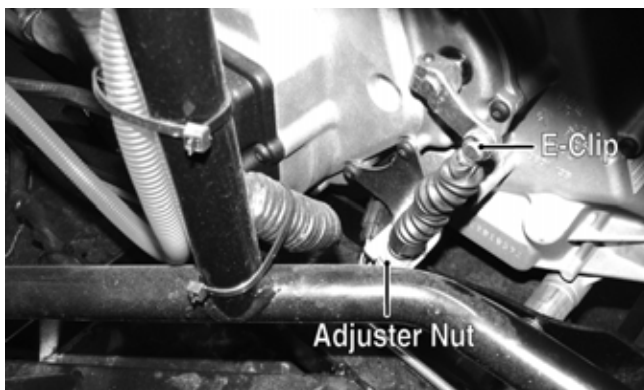

HDX137B

- Remove the center floorboard and remove all nylon ties securing the cable housing to the frame; then remove the shift cable.

■ **NOTE:** If the cable is being replaced, connect the new cable to the end of the cable being removed and pull the new cable into place.

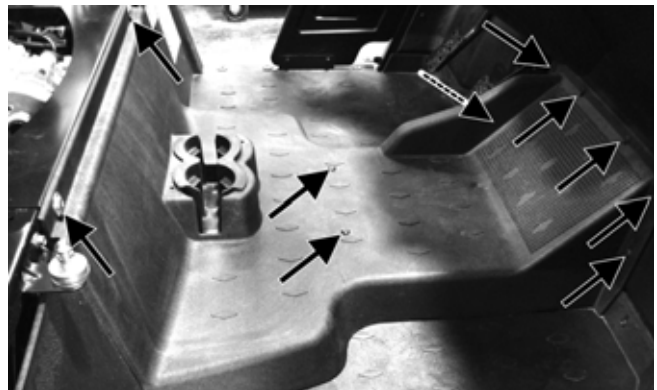

HDX132A

INSTALLING

- Route the cable into position making sure there are no kinks or sharp bends.
- Install the cable housing onto the transmission holder; then connect the cable end to the shift arm and secure with the E-clip.
- Install the shift cable into the shift cable support; then connect the shift cable end to the shifter and secure with a cap screw and nut. Tighten to 8 ft-lb.
- Adjust the shift cable (see Shift Lever - Adjusting Shift Cable in section 2).
- Install nylon ties on the shift cable where removed; then install the center floorboard and tighten the machine screws securely.
- Install the dashboard (see Dashboard, Installing in section 8).
- Shift the transmission through all positions making sure the gear position icons indicate the appropriate gears selected and that the Park Indicator illuminates only when fully in Park. (See Shift Lever - Checking Shift Cable Adjustment in section 2).

Speedometer/Tachometer/ LCD/Indicator Lights

9

REPLACING

- Remove the steering wheel; then remove the steering wheel boot.
- Remove the two machine screws securing the steering wheel boot support to the steering support assembly. Remove the boot support.



PR762A

3. Remove the six screws securing the dash panel to the frame; then remove the shifter handle and shift lever boot.
4. Slide the dash panel to the rear sufficiently to access the components.

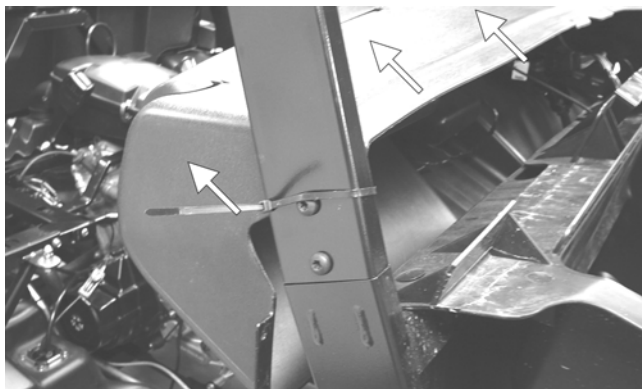

PR181A

5. Remove the nuts securing the gauge assembly to the dash; then unplug the multi-pin connector and remove the gauge from the vehicle.

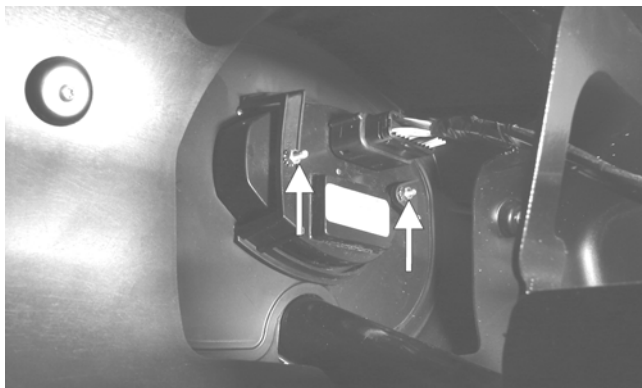

PR284A

6. Place the new gauge into the dash panel opening; then place the gauge holder over the mounting screws and secure with the nuts.

7. Plug the multi-pin connector into the gauge; then turn the ignition switch to the ON position and check gauge functions.
8. Slide the dash into position and secure with the six screws.
9. Install the shifter handle; then install the steering boot support.



PR762A

10. Install the steering boot onto the boot support.
11. Install the steering wheel; then with a drop of red Loctite #271 on the threads of the steering shaft, install the nut and tighten to 25 ft-lb.
12. Install the lock clip and steering wheel cover.

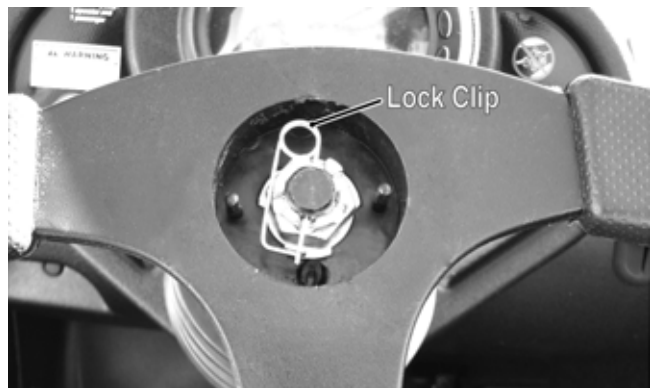

HDX131A

