



FOREWORD

This manual contains service, maintenance, and troubleshooting information for the 2008 Arctic Cat DVX 400 ATV model. The manual is designed to aid service personnel in service-oriented applications and may be used as a textbook for service training.

This manual is divided into sections. Each section covers a specific ATV component or system and, in addition to the standard service procedures, includes disassembling, inspecting, and assembling instructions. When using this manual as a guide, the technician should use discretion as to how much disassembly is needed to correct any given condition. A troubleshooting section is also included in this manual.

The service technician should become familiar with the operation and construction of each component or system by carefully studying this manual. This manual will assist the service technician in becoming more aware of and efficient with servicing procedures. Such efficiency not only helps build consumer confidence but also saves time and labor.

All Arctic Cat ATV publications and decals display the words Warning, Caution, Note, and At This Point to emphasize important information. The symbol  **WARNING** identifies personal safety-related information. Be sure to follow the directive because it deals with the possibility of severe personal injury or even death. The symbol  **CAUTION** identifies unsafe practices which may result in ATV-related damage. Follow the directive because it deals with the possibility of damaging part or parts of the ATV. The symbol  **NOTE:** identifies supplementary information worthy of particular attention. The symbol  **AT THIS POINT** directs the technician to certain and specific procedures to promote efficiency and to improve clarity.

At the time of publication, all information, photographs, and illustrations were technically correct. Some photographs used in this manual are used for clarity purposes only and are not designed to depict actual conditions. Because Arctic Cat Inc. constantly refines and improves its products, no retroactive obligation is incurred.

All materials and specifications are subject to change without notice.

Keep this manual accessible in the shop area for reference.

Product Service and
Warranty Department
Arctic Cat Inc.

TABLE OF CONTENTS

Foreword

Click on the red text to go.

Section

MORE TO GO ON.™

1. General Information	DVX 400	1
2. Periodic Maintenance/Tune-Up		2
3. Engine/Transmission		3
4. Fuel/Lubrication/Cooling		4
5. Electrical System		5
6. Drive System		6
7. Suspension		7
8. Steering/Frame		8
9. Controls/Indicators		9
10. Aids for Maintenance		10
11. Troubleshooting		11

SECTION 1 - GENERAL INFORMATION

TABLE OF CONTENTS

General Specifications	1-2
Break-In Procedure	1-2
Gasoline - Oil - Lubricant	1-2
Genuine Parts	1-3
Preparation For Storage.....	1-3
Preparation After Storage.....	1-4

General Specifications*

CHASSIS	
Dry Weight (approx)	169 kg (373 lb)
Length (overall)	183 cm (72 in.)
Height (overall)	116 cm (45.7 in.)
Width (overall)	116.5 cm (45.8 in.)
Suspension Travel	Front - 21.6 cm (8.5 in.) Rear - 23.1 cm (9.1 in.)
Ground Clearance	26.5 cm (10.4 in.)
Brake Type	Hydraulic Disc and Mechanical Parking Brake
Wheelbase	124.5 cm (49 in.)
Tire Size	Front - AT22 x 7R10 Rear - AT20 x 10R9
Tire Inflation Pressure	Front - 0.30 kg/cm ² (4.4 psi) Rear - 0.275 kg/cm ² (4.0 psi)
Turning Radius	3.1 m (10.2 ft)
MISCELLANY	
Gas Tank Capacity (rated)	10.0 L (2.6 U.S. gal.)
Reserve Capacity	0.7 L (0.18 U.S. gal.)
Engine Oil Capacity	2.1 L (2.2 U.S. qt)
Gasoline (recommended)	87 Octane Regular Unleaded
Engine Oil (recommended)	SAE 10W-40
Cooling System Capacity	1.2 L (1.3 U.S. qt)
Brake Fluid	DOT 4
Taillight/Brakelight	12V/5W/21W
Headlight	12V/27W (2)/12V/50W (1)
Starting System	Electric

* Specifications subject to change without notice.

Break-In Procedure

A new ATV and an overhauled ATV engine require a “break-in” period. The first 10 hours (or 200 miles) are most critical to the life of this ATV. Proper operation during this break-in period will help assure maximum life and performance from the ATV.

During the first 10 hours (or 200 miles) of operation, always use less than 1/2 throttle. Varying the engine RPM during the break-in period allows the components to “load” (aiding the mating process) and then “unload” (allowing components to cool). Although it is essential to place some stress on the engine components during break-in, care should be taken not to overload the engine too often. Do not pull a trailer or carry heavy loads during the 10-hour break-in period.

When the engine starts, allow it to warm up properly. Idle the engine several minutes until the engine has reached normal operating temperature. Do not idle the engine for excessively long periods of time.

During the break-in period, a maximum of 1/2 throttle is recommended; however, brief full-throttle accelerations and variations in driving speeds contribute to good engine break-in.

During the break-in period (or whenever the brake pads are replaced), the hydraulic brake pads must be burnished. Slow disc-speed hydraulic brakes must be properly burnished in order to achieve maximum stopping power.

CAUTION

BRAKE PADS MUST BE BURNISHED TO ACHIEVE FULL BRAKING EFFECTIVENESS. Braking distance will be extended until brake pads are properly burnished.

TO PROPERLY BURNISH THE BRAKES, USE FOLLOWING PROCEDURE:

- Choose an area sufficiently large to safely accelerate ATV to 30 mph and to brake to a stop.
- Accelerate to 30 mph; then apply front and rear brakes to decelerate to 0-5 mph.
- Repeat procedure five times.
- This procedure burnishes the brake pads, stabilizes the pad material, and extends the life of the brake pads.

WARNING

Do not attempt sudden stops or put the ATV into a situation where a sudden stop will be required until the brake pads are properly burnished.

NOTE: Do not be reluctant to heat up the brake pads during the burnishing procedure.

After the completion of the break-in period, the engine oil and oil filter should be changed. Other maintenance after break-in should include checking of all prescribed adjustments and tightening of all fasteners.

Gasoline - Oil - Lubricant

RECOMMENDED GASOLINE

The recommended gasoline to use is 87 minimum octane regular unleaded. In many areas, oxygenates (either ethanol or MTBE) are added to the gasoline. Oxygenated gasolines containing up to 10% ethanol, 5% methane, or 5% MTBE are acceptable gasolines.

When using ethanol blended gasoline, it is not necessary to add a gasoline antifreeze since ethanol will prevent the accumulation of moisture in the fuel system.

⚠ CAUTION

Do not use white gas. Only Arctic Cat approved gasoline additives should be used.

RECOMMENDED ENGINE/ TRANSMISSION OIL

⚠ CAUTION

Any oil used in place of the recommended oil could cause serious engine damage. Do not use oils which contain graphite or molybdenum additives. These oils can adversely affect clutch operation. Also, not recommended are racing, vegetable, non-detergent, and castor-based oils.

The recommended oil to use is Arctic Cat 4-Cycle Engine Oil or an equivalent oil which is rated SE, SF, or SG under API service classification. These oils meet all of the lubrication requirements of the Arctic Cat ATV engine. The recommended engine oil viscosity is SAE 10W-40. Ambient temperature should determine the correct weight of oil. See the following viscosity chart for details.

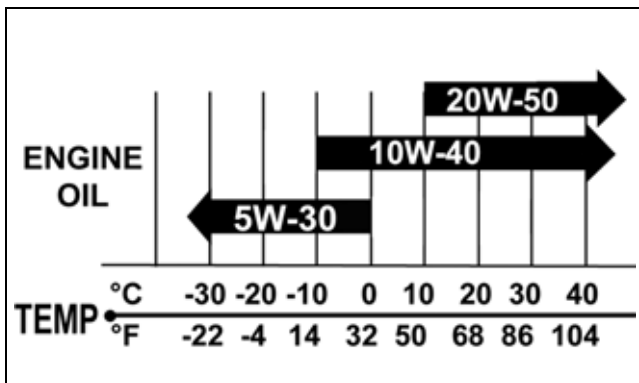

OILCHARTA

FILLING GAS TANK

⚠ WARNING

Always fill the gas tank in a well-ventilated area. Never add fuel to the ATV gas tank near any open flames or with the engine running. DO NOT SMOKE while filling the gas tank.

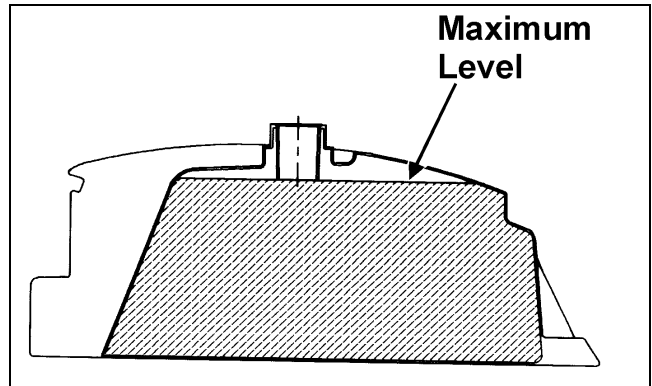

ATV0049B

Since gasoline expands as its temperature rises, the gas tank must be filled to its rated capacity only. Expansion room must be maintained in the tank particularly if the tank is filled with cold gasoline and then moved to a warm area.

1

⚠ WARNING

Do not overflow gasoline when filling the gas tank. A fire hazard could materialize. Always allow the engine to cool before filling the gas tank.

Tighten the gas tank cap securely after filling the tank.

⚠ WARNING

Do not over-fill the gas tank.

Genuine Parts

When replacement of parts is necessary, use only genuine Arctic Cat ATV parts. They are precision-made to ensure high quality and correct fit. Refer to the Illustrated Parts Manual for the correct part number, quantity, and description.

Preparation For Storage

⚠ CAUTION

Prior to storing the ATV, it must be properly serviced to prevent rusting and component deterioration.

Arctic Cat recommends the following procedure to prepare the ATV for storage.

1. Clean the seat cushion (cover and base) with a damp cloth and allow it to dry.
2. Clean the ATV thoroughly by washing dirt, oil, grass, and other foreign matter from the entire ATV. Allow the ATV to dry thoroughly. DO NOT get water into any part of the engine or air intake.

3. Either drain the gas tank or add Fuel Stabilizer to the gas in the gas tank. Remove the air filter housing cover and air filter. Start the engine and allow it to idle; then using Arctic Cat Engine Storage Preserver, rapidly inject the preserver into the air filter opening for a period of 10 to 20 seconds; then stop the engine. Install the air filter and housing cover.

⚠ CAUTION

If the interior of the air filter housing is dirty, clean the area before starting the engine.

4. Drain the carburetor float chamber.
5. Plug the exhaust hole in the exhaust system with a clean cloth.
6. Apply light oil to the upper steering post bushing, plungers of the shock absorbers, and drive chain.
7. Tighten all nuts, bolts, cap screws, and screws. Make sure rivets holding components together are tight. Replace all loose rivets. Care must be taken that all calibrated nuts, cap screws, and bolts are tightened to specifications.
8. Fill the cooling system to the upper level line on the overflow tank with properly mixed coolant.
9. Disconnect the battery cables; then remove the battery, clean the battery posts and cables, and store in a clean, dry area.

⚠ CAUTION

This maintenance-free battery should be charged at the recommended rate every 30 days or permanent damage will result if the battery completely discharges.

10. Store the ATV indoors in a level position.

⚠ CAUTION

Avoid storing outside in direct sunlight and avoid using a plastic cover as moisture will collect on the ATV causing rusting.

Preparation After Storage

Taking the ATV out of storage and correctly preparing it will assure many miles and hours of trouble-free riding. Arctic Cat recommends the following procedure to prepare the ATV.

1. Clean the ATV thoroughly.
2. Clean the engine. Remove the cloth from the exhaust system.
3. Check all control wires and cables for signs of wear or fraying. Replace if necessary.
4. Change the engine/transmission oil and filter.
5. Check the coolant level and add properly mixed coolant as necessary.
6. Charge the battery; then install. Connect the battery cables.

⚠ CAUTION

This maintenance-free battery should be charged at the recommended rate every 30 days or permanent damage will result if the battery completely discharges.

7. Check the entire brake systems (fluid level, pads, etc.), all controls, headlights, taillight, brakelight, and headlight aim; adjust or replace as necessary.
8. Tighten all nuts, bolts, cap screws, and screws making sure all calibrated nuts, cap screws, and bolts are tightened to specifications.
9. Check tire pressure. Inflate to recommended pressure as necessary.
10. Make sure the steering moves freely and does not bind.
11. Check the spark plug. Clean or replace as necessary.
12. Follow the recommendations found in the pre-start inspection.
13. Inspect the drive chain and sprockets. Adjust or replace as necessary.

SECTION 2 - PERIODIC MAINTENANCE/TUNE-UP

2

TABLE OF CONTENTS

Periodic Maintenance Chart.....	2-2
Lubrication Points.....	2-3
Battery.....	2-3
Fuses.....	2-4
Air Cleaner.....	2-4
Valve/Tappet Clearance.....	2-6
Tappet Shim Selection Table (Exhaust).....	2-9
Tappet Shim Selection Table (Intake).....	2-10
Testing Engine Compression.....	2-11
Spark Plug.....	2-11
Muffler/Spark Arrester.....	2-11
Gas/Vent Hoses.....	2-12
Adjusting Throttle Cable.....	2-12
Adjusting Engine RPM (Idle).....	2-12
Engine/Transmission Oil - Filter.....	2-13
Adjusting Clutch Lever Cable.....	2-14
Tires.....	2-14
Steering Components.....	2-14
Suspension/Shock Absorbers/Bushings.....	2-15
Nuts/Bolts/Cap Screws.....	2-15
Headlight/Taillight-Brakelight.....	2-15
Switches.....	2-16
Indicator Lights.....	2-16
Frame/Welds.....	2-17
Electrical Connections.....	2-17
Hydraulic/Parking Brake Systems.....	2-17
Burnishing Brake Pads.....	2-21
Coolant.....	2-21
Drive Chain.....	2-22

Periodic Maintenance Chart

A = Adjust I = Inspect
 C = Clean L = Lubricate
 CH = Charge D = Drain
 R = Replace

Item	Initial Service After Break-In (First Mo)	Every Day	Every Month	Every 3 Months	Every 6 Months	Every Year	As Needed
Battery			CH				C
Fuse				I			R
Air Filter/Drain Tube	I	I	C*				R
Valve/Tappet Clearance	I				I		A
Engine Compression						I	
Spark Plug	I				I		R (18 Mo)
Muffler/Spark Arrester					C		R
Gas/Vent Hoses	I	I					R (2 Yrs)
Gas Tank Valve						I	C
Throttle Cable	I	I			C-L		A-R
Carb Float Chamber				D*			
Engine RPM (Idle)	I				I		A
Engine-Transmission Oil Level		I					A
Engine-Transmission Oil/Filter	R			R*			R
Oil Strainer	I				I		C
Drive Chain	I	I	A				R
Clutch	I				I		A
Tires/Air Pressure	I	I					R
Steering Components	I	I					R
Coolant Hoses	I				I		R (4 Yrs)
Suspension (Ball joint and tie rod boots, tie rods, and shock mounts)	I			I*			R
Nuts/Cap Screws/Screws	I	I					A
Oil Lines	I	I					
Headlight/Taillight-Brakelight	I	I					R
Switches	I	I					R
Reverse Selector Cable	I				I		A-L
Choke Cable	I			I	C-L		R
Handlebar Grips		I					R
Handlebars	I	I					R
Indicator Lights	I	I					R
Frame/Welds	I		I		I		
Electrical Connections					I		C
Complete Brake Systems (Hydraulic and Parking)	I	I		C			L-R
Brake Pads	I			I*			R
Brake Fluid	I			I			R (2 Yrs)
Brake Hoses	I			I			R (4 Yrs)
Brake Cable (Parking)		I-A					
Coolant/Cooling System	I		I				R (2 Yrs)

* Service/Inspect more frequently when operating in adverse conditions.



Lubrication Points

It is advisable to lubricate certain components periodically to ensure free movement. Apply light oil to the components using the following list as reference.

- A. Throttle Lever Pivot/Cable Ends
- B. Brake Lever Pivot
- C. Parking Brake Cable Ends
- D. Choke Cable Upper End
- E. Reverse Selector Cable End
- F. Idle RPM Screw (Carburetor)
- G. Rear Brake Pedal Pivot

Battery

The battery is located under the seat.

After being in service, batteries require regular cleaning and recharging in order to deliver peak performance and maximum service life. The following procedure is recommended for cleaning and maintaining a sealed battery. Always read and follow instructions provided with battery chargers and battery products.

WARNING

Anytime service is performed on a battery, the following must be observed: keep sparks, open flame, cigarettes, or any other flame away. Always wear safety glasses. Protect skin and clothing when handling a battery. When servicing battery in enclosed space, keep the area well-ventilated.

1. Remove the battery hold-down; then disconnect the battery cables (negative cable first).
2. Remove the battery from the battery compartment; then thoroughly wash the battery and battery compartment with soap and water.

NOTE: If battery posts, cable ends, or the battery case has a build-up of white/green powder residue, apply water and baking soda to neutralize acid; then flush off with warm soapy water.

3. Using a wire brush, clean the battery posts and cable ends removing all corrosive buildup. Replace damaged cables or cable ends.

CAUTION

Do not remove seal strip.

WARNING

Battery acid is harmful if it contacts eyes, skin, or clothing. Care must be taken whenever handling a battery.

4. Using a multimeter, test the battery voltage. The meter must read at least 12.5 DC Volts for a fully charged battery.

NOTE: At this point if the meter reads as specified, the battery may be returned to service (see step 8).

5. If the meter reads less than specified voltage, charge the battery using the following guidelines.

- A. When using an automatic battery charger, always follow the charger manufacturer's instructions.
- B. When using a constant-current battery charger, use the following Battery Charging Chart.

CAUTION

Never exceed the standard charging rate.

WARNING

An overheated battery could explode causing severe injury or death. Always monitor charging times and charge rates carefully. Stop charging if the battery becomes very warm to the touch. Allow it to cool before resuming charging.

Battery Charging Chart (Constant-Current Charger)

Battery Voltage (DC)	Charge State	Charge Time Required (at 1.5-2.0 Amps)
12.5 or more	100%	None
12.2-12.4	75%-99%	3-6 hours
12.0-12.2	50%-74%	5-11 hours
11.0-11.9	25%-49%	13 hours (minimum)
11.5 or less	0-24%	20 hours (minimum)

NOTE: If the battery voltage is 11.5 DC Volts or less, some chargers may "cut off" and fail to charge. If this occurs, connect a fully charged booster battery in parallel (positive to positive and negative to negative) for a short period of time with the charger connected. After 10-15 minutes, disconnect the booster battery leaving the charger connected and the charger should continue to charge. If the charger "cuts off," replace the battery.

6. After charging the battery for the specified time, remove the battery charger and allow the battery to sit for 1-2 hours.
7. Connect the multimeter and test the battery voltage. The meter should read at least 12.5 DC Volts. If the voltage is as specified, the battery is ready for service.

■NOTE: If voltage in step 7 is below specifications, charge the battery an additional 1-5 hours; then retest.

8. Place the battery in the battery compartment; then coat the battery posts and cable ends with a light coat of multi-purpose grease.

⚠ CAUTION

Before installing the battery, make sure the ignition switch is in the OFF position.

9. Connect the battery cables (positive cable first); then install the battery hold-down.

⚠ CAUTION

Connecting cables in reverse (positive to negative and negative to positive) can cause serious damage to the electrical system.

Fuses

There is one 20 amp fuse and one spare 20 amp fuse located adjacent to the battery on the starter relay.

If there is any type of electrical system failure, always check the fuse first.

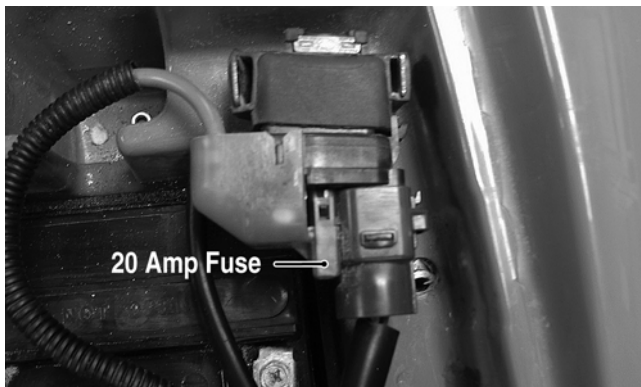

SP032A

⚠ CAUTION

Always replace a blown fuse with a fuse of the same type and rating.

Air Cleaner

CLEANING AND INSPECTING FILTER

⚠ CAUTION

Failure to inspect the air filter frequently if the ATV is used in dusty, wet, or muddy conditions can damage the ATV engine.

1. Remove the seat.
2. Unseat the two retaining clips securing the air cleaner housing cover; then remove the cover.



SP014A

3. Remove the screw securing the air filter stopper and set aside; then remove the filter assembly.

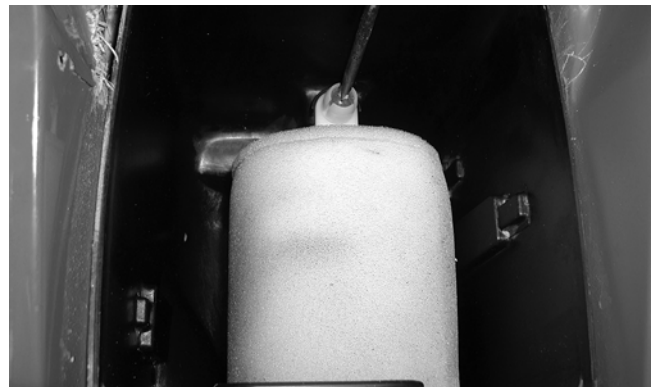

SP012

4. Remove the foam wrap from the filter frame.

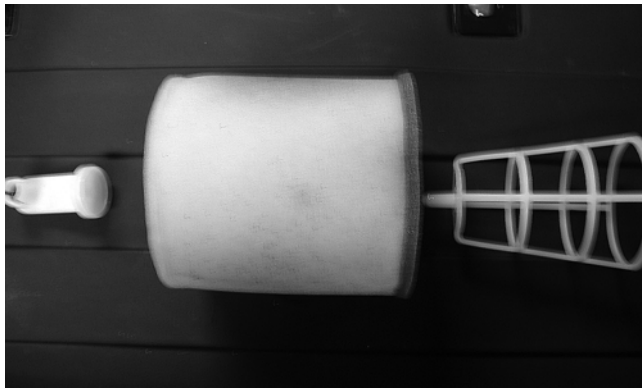

SP013

5. Fill a wash pan larger than the filter with a non-flammable cleaning solvent; then dip the filter in the solvent and wash it.

■NOTE: Foam Filter Cleaner and Foam Filter Oil are available from Arctic Cat.

6. Dry the filter.
7. Put the filter in a plastic bag; then pour in air filter oil and work the filter.

⚠ CAUTION

A torn air filter can cause damage to the ATV engine. Dirt and dust may get inside the engine if the element is torn. Carefully examine the element for tears before and after cleaning it. Replace the element with a new one if it is torn.

8. Clean any dirt or debris from inside the air cleaner. Be sure no dirt enters the carburetor.
9. Place the filter in the air filter housing making sure it is properly in position and properly seated and secure with the stopper and screw.
10. Install the air filter housing cover and secure with the retaining clips; then install the seat making sure the seat is properly secured.

CHECKING/DRAINING DRAIN TUBE

1. Periodically check the drain tube for gasoline or oil accumulation. If noticed, remove the drain tube cap from beneath the front housing, drain the gasoline or oil into a suitable container, and install and secure the tube cap.
2. Inspect one-way drain tube beneath the main housing for debris and for proper sealing.

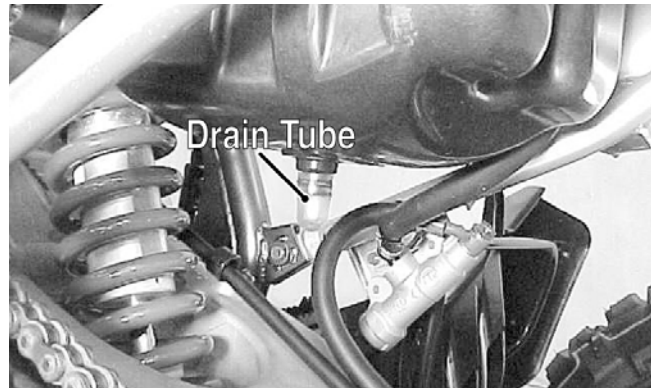

SP119

REMOVING

1. Remove the seat.
2. Unseat the two retaining clips securing the air cleaner housing; then remove the cover.

2



SP014A

3. Remove the screw securing the air filter stopper and set aside; then remove the air filter.

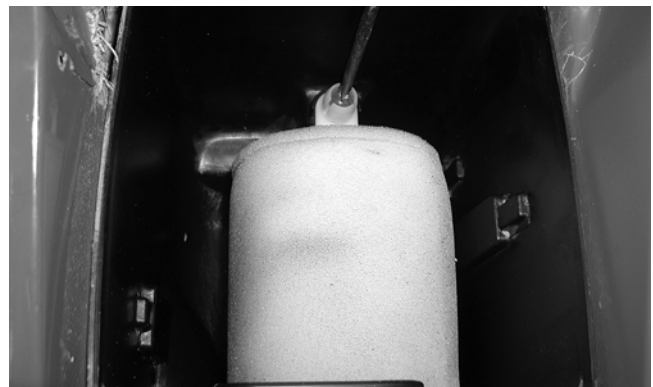

SP012

4. Loosen the clamp securing the air cleaner to the inlet duct; then loosen the clamp securing the air cleaner to the outlet tube.
5. Remove the cap screws securing the air cleaner to the frame.
6. Remove the air cleaner from the frame.

INSTALLING

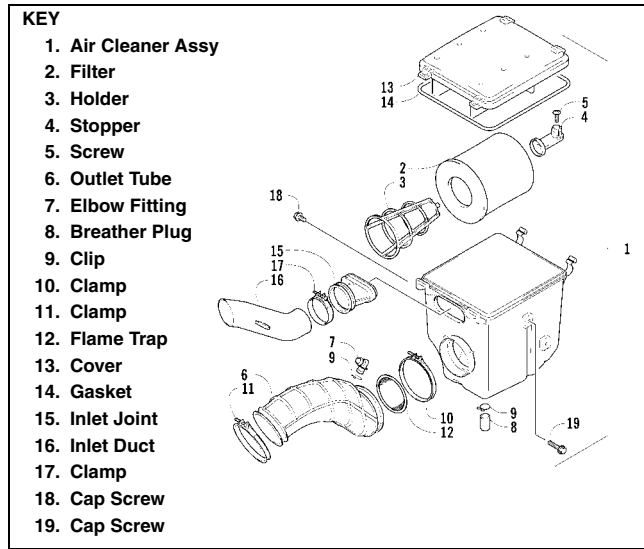

0739-212

1. Place the air cleaner into the frame.
2. Install the cap screws securing the air cleaner to the frame.
3. Install the outlet tube onto the air cleaner; then tighten the clamp securely.
4. Install the inlet duct onto the air cleaner; then tighten the clamp securely.
5. Install the filter with foam wrap into the air cleaner; then tighten the filter stopper screw securely.

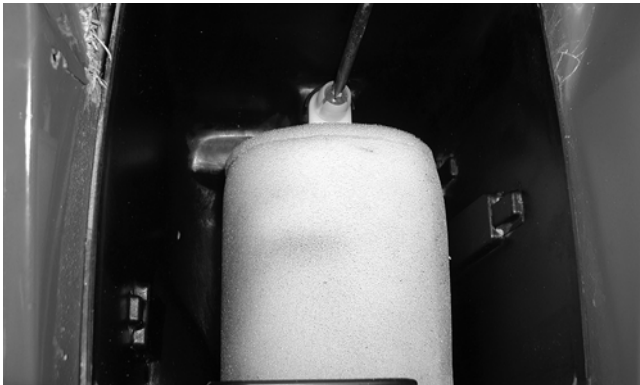

SP012

6. Place the air cleaner cover into position and secure with the retaining clips.



SP014A

7. Install the seat making sure the seat is properly secured.

Valve/Tappet Clearance

CHECKING

To check and adjust valve/tappet clearance, use the following procedure.

1. Remove the seat, gas tank cover, and body.
2. Turn the fuel valve to the ON position; then remove the gas tank.
3. Disconnect the engine oil hose (3) and the engine oil breather hose (4); then remove the spark plug.

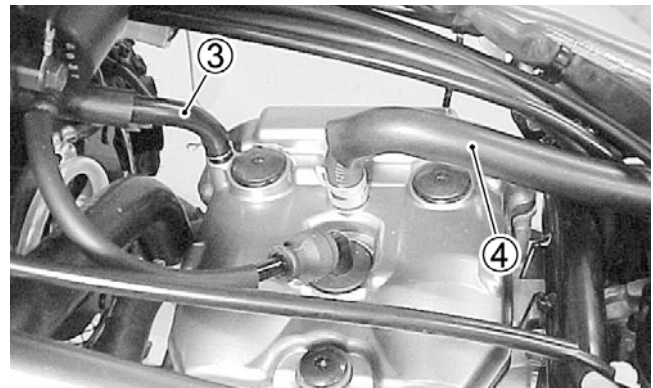

SP120

4. Remove the three large Allen-head cap screws securing the valve cover; then remove the valve cover accounting for the two camshaft end plugs and the valve cover gasket.

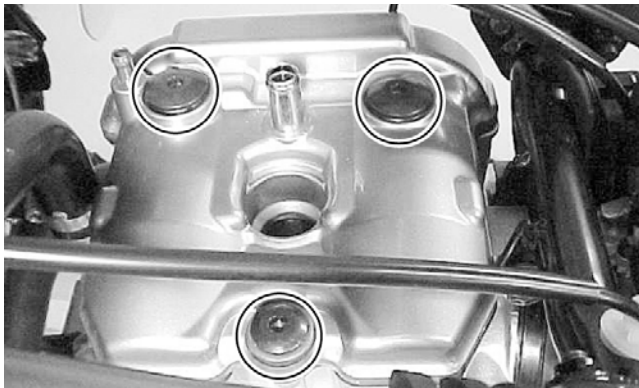

SP121

■NOTE: The valve/tappet clearance specification is different for intake and exhaust valves. The clearance should only be checked when the engine is cold (room temperature).

■NOTE: Valve/tappet clearance adjustment must be checked and adjusted in accordance with the periodic maintenance chart or anytime valve mechanism components are removed and reinstalled.

5. Remove the valve timing inspection plug (1) and the generator cover cap (2); then rotate the crankshaft with a socket wrench to top-dead-center (TDC) on the compression stroke. The "T" line on the alternator rotor is aligned with the triangle mark on the alternator cover.

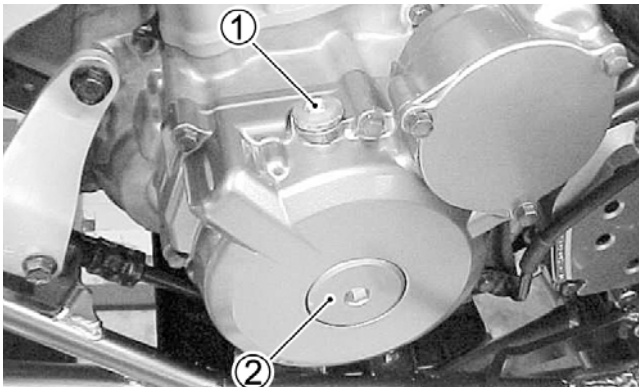

SP122

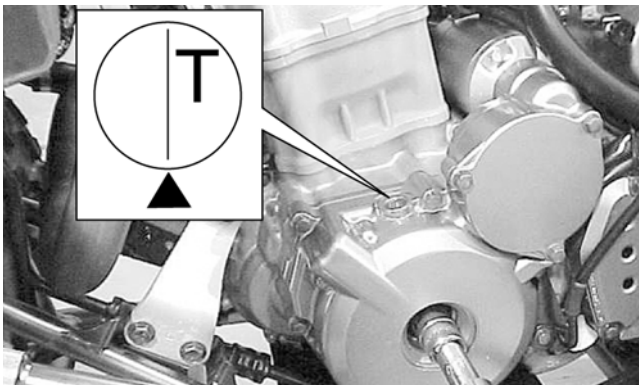

SP123

■NOTE: The camshaft lobes must be in position (A) in order to check valve/tappet clearance.

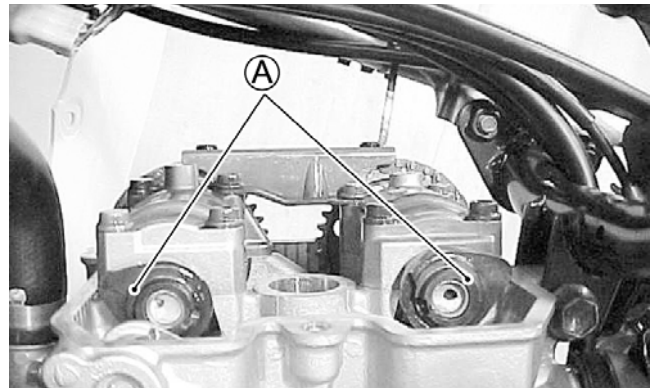

SP124

6. Insert a feeler gauge between the tappet and the camshaft. The clearance must be within specifications.



SP125

If the clearance is out of specifications, adjust the clearance using the following procedure.

ADJUSTING

The clearance is adjusted by replacing the existing tappet shim with a thicker or thinner shim.

1. Remove the camshaft corresponding to the out-of-tolerance tappet (see Section 3).
2. Using a magnet, remove the tappet and shim; then check the numbers printed on the tappet shim.

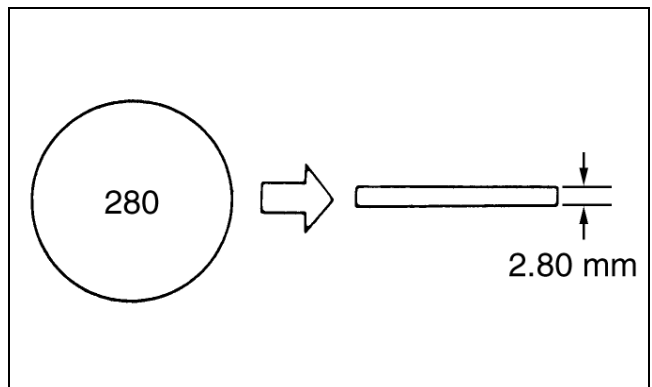

ATV2151

■NOTE: These numbers indicate the thickness of the tappet shim as illustrated.

3. Select a replacement tappet shim that will provide the proper clearance.

■NOTE: Tappet shims are available in 25 sizes from 2.30-3.50 mm (0.09-0.14 in.) in 0.05 mm (0.002 in.) increments.

4. Install the selected shim at the valve stem with the numbers facing the tappet. Be sure to measure the shim with a micrometer to ensure it is the proper size. Refer to the tappet shim selection table for details.

■NOTE: Apply molybdenum oil solution to the top and bottom of the tappet shim. Make sure that the numbered side is directed toward the tappet.

5. Install the camshaft (see Section 3).
6. Rotate the crankshaft through two full revolutions to ensure that all excess oil is squeezed from the valve/tappet clearance to make sure it is within specifications.
7. Apply Three Bond Sealant to the camshaft end caps of the valve cover gasket; then install the valve cover.
8. Tighten the valve cover cap screws to specifications (see Section 10).
9. Install the spark plug and tighten to specifications (see Section 10); then install the timing inspection plug.

TAPPET SHIM SELECTION TABLE (EXHAUST)
TAPPET SHIM SET (p/n 3402-931)

MEASURED TAPPET CLEARANCE (mm)	SPECIFIED CLEARANCE/NO ADJUSTMENT REQUIRED																										
	SUFFIX NO.	230	235	240	245	250	255	260	265	270	275	280	285	290	295	300	305	310	315	320	325	330	335	340	345	350	
0.00-0.04	2.30	2.35	2.40	2.45	2.50	2.55	2.60	2.65	2.70	2.75	2.80	2.85	2.90	2.95	3.00	3.05	3.10	3.15	3.20	3.25	3.30	3.35	3.40	3.45	3.50	3.50	
0.05-0.09				2.30	2.35	2.40	2.45	2.50	2.55	2.60	2.65	2.70	2.75	2.80	2.85	2.90	2.95	3.00	3.05	3.10	3.15	3.20	3.25	3.30	3.35	3.40	3.50
0.10-0.14			2.30	2.35	2.40	2.45	2.50	2.55	2.60	2.65	2.70	2.75	2.80	2.85	2.90	2.95	3.00	3.05	3.10	3.15	3.20	3.25	3.30	3.35	3.40	3.45	3.50
0.15-0.19			2.30	2.35	2.40	2.45	2.50	2.55	2.60	2.65	2.70	2.75	2.80	2.85	2.90	2.95	3.00	3.05	3.10	3.15	3.20	3.25	3.30	3.35	3.40	3.45	3.50
0.20-0.30																											
0.31-0.35	2.40	2.45	2.50	2.55	2.60	2.65	2.70	2.75	2.80	2.85	2.90	2.95	3.00	3.05	3.10	3.15	3.20	3.25	3.30	3.35	3.40	3.45	3.50	3.50	3.50	3.50	
0.36-0.40	2.45	2.50	2.55	2.60	2.65	2.70	2.75	2.80	2.85	2.90	2.95	3.00	3.05	3.10	3.15	3.20	3.25	3.30	3.35	3.40	3.45	3.50	3.50	3.50	3.50	3.50	
0.41-0.45	2.50	2.55	2.60	2.65	2.70	2.75	2.80	2.85	2.90	2.95	3.00	3.05	3.10	3.15	3.20	3.25	3.30	3.35	3.40	3.45	3.50	3.50	3.50	3.50	3.50	3.50	
0.46-0.50	2.55	2.60	2.65	2.70	2.75	2.80	2.85	2.90	2.95	3.00	3.05	3.10	3.15	3.20	3.25	3.30	3.35	3.40	3.45	3.50	3.50	3.50	3.50	3.50	3.50	3.50	
0.51-0.55	2.60	2.65	2.70	2.75	2.80	2.85	2.90	2.95	3.00	3.05	3.10	3.15	3.20	3.25	3.30	3.35	3.40	3.45	3.50	3.50	3.50	3.50	3.50	3.50	3.50	3.50	
0.56-0.60	2.65	2.70	2.75	2.80	2.85	2.90	2.95	3.00	3.05	3.10	3.15	3.20	3.25	3.30	3.35	3.40	3.45	3.50	3.50	3.50	3.50	3.50	3.50	3.50	3.50	3.50	
0.61-0.65	2.70	2.75	2.80	2.85	2.90	2.95	3.00	3.05	3.10	3.15	3.20	3.25	3.30	3.35	3.40	3.45	3.50	3.50	3.50	3.50	3.50	3.50	3.50	3.50	3.50	3.50	
0.66-0.70	2.75	2.80	2.85	2.90	2.95	3.00	3.05	3.10	3.15	3.20	3.25	3.30	3.35	3.40	3.45	3.50	3.50	3.50	3.50	3.50	3.50	3.50	3.50	3.50	3.50	3.50	
0.71-0.75	2.80	2.85	2.90	2.95	3.00	3.05	3.10	3.15	3.20	3.25	3.30	3.35	3.40	3.45	3.50	3.50	3.50	3.50	3.50	3.50	3.50	3.50	3.50	3.50	3.50	3.50	
0.76-0.80	2.85	2.90	2.95	3.00	3.05	3.10	3.15	3.20	3.25	3.30	3.35	3.40	3.45	3.50	3.50	3.50	3.50	3.50	3.50	3.50	3.50	3.50	3.50	3.50	3.50	3.50	
0.81-0.85	2.90	2.95	3.00	3.05	3.10	3.15	3.20	3.25	3.30	3.35	3.40	3.45	3.50	3.50	3.50	3.50	3.50	3.50	3.50	3.50	3.50	3.50	3.50	3.50	3.50	3.50	
0.86-0.90	2.95	3.00	3.05	3.10	3.15	3.20	3.25	3.30	3.35	3.40	3.45	3.50	3.50	3.50	3.50	3.50	3.50	3.50	3.50	3.50	3.50	3.50	3.50	3.50	3.50	3.50	
0.91-0.95	3.00	3.05	3.10	3.15	3.20	3.25	3.30	3.35	3.40	3.45	3.50	3.50	3.50	3.50	3.50	3.50	3.50	3.50	3.50	3.50	3.50	3.50	3.50	3.50	3.50	3.50	
0.96-1.00	3.05	3.10	3.15	3.20	3.25	3.30	3.35	3.40	3.45	3.50	3.50	3.50	3.50	3.50	3.50	3.50	3.50	3.50	3.50	3.50	3.50	3.50	3.50	3.50	3.50	3.50	
1.01-1.05	3.10	3.15	3.20	3.25	3.30	3.35	3.40	3.45	3.50	3.50	3.50	3.50	3.50	3.50	3.50	3.50	3.50	3.50	3.50	3.50	3.50	3.50	3.50	3.50	3.50	3.50	
1.06-1.10	3.15	3.20	3.25	3.30	3.35	3.40	3.45	3.50	3.50	3.50	3.50	3.50	3.50	3.50	3.50	3.50	3.50	3.50	3.50	3.50	3.50	3.50	3.50	3.50	3.50	3.50	
1.11-1.15	3.20	3.25	3.30	3.35	3.40	3.45	3.50	3.50	3.50	3.50	3.50	3.50	3.50	3.50	3.50	3.50	3.50	3.50	3.50	3.50	3.50	3.50	3.50	3.50	3.50	3.50	
1.16-1.20	3.25	3.30	3.35	3.40	3.45	3.50	3.50	3.50	3.50	3.50	3.50	3.50	3.50	3.50	3.50	3.50	3.50	3.50	3.50	3.50	3.50	3.50	3.50	3.50	3.50	3.50	
1.21-1.25	3.30	3.35	3.40	3.45	3.50	3.50	3.50	3.50	3.50	3.50	3.50	3.50	3.50	3.50	3.50	3.50	3.50	3.50	3.50	3.50	3.50	3.50	3.50	3.50	3.50	3.50	
1.26-1.30	3.35	3.40	3.45	3.50	3.50	3.50	3.50	3.50	3.50	3.50	3.50	3.50	3.50	3.50	3.50	3.50	3.50	3.50	3.50	3.50	3.50	3.50	3.50	3.50	3.50	3.50	
1.31-1.35	3.40	3.45	3.50	3.50	3.50	3.50	3.50	3.50	3.50	3.50	3.50	3.50	3.50	3.50	3.50	3.50	3.50	3.50	3.50	3.50	3.50	3.50	3.50	3.50	3.50	3.50	
1.36-1.40	3.45	3.50	3.50	3.50	3.50	3.50	3.50	3.50	3.50	3.50	3.50	3.50	3.50	3.50	3.50	3.50	3.50	3.50	3.50	3.50	3.50	3.50	3.50	3.50	3.50	3.50	
1.41-1.45	3.50	3.50	3.50	3.50	3.50	3.50	3.50	3.50	3.50	3.50	3.50	3.50	3.50	3.50	3.50	3.50	3.50	3.50	3.50	3.50	3.50	3.50	3.50	3.50	3.50	3.50	
1.46-1.50	3.50	3.50	3.50	3.50	3.50	3.50	3.50	3.50	3.50	3.50	3.50	3.50	3.50	3.50	3.50	3.50	3.50	3.50	3.50	3.50	3.50	3.50	3.50	3.50	3.50	3.50	

How to use this chart:

- I. Measure tappet clearance when the engine is cold.
- II. Measure present shim size.
- III. Match clearance in vertical column with present shim size in horizontal column.

Example:

Tappet clearance is 0.38 mm
Present shim size 2.90 mm
Shim size to be used 3.05 mm



Back to TOC

Back to Section TOC



TAPPET SHIM SELECTION TABLE (INTAKE)
TAPPET SHIM SET (p/n 3402-931)

MEASURED TAPPET CLEARANCE (mm)	SUFFIX NO.	SPECIFIED CLEARANCE/NO ADJUSTMENT REQUIRED																											
		230	235	240	245	250	255	260	265	270	275	280	285	290	295	300	305	310	315	320	325	330	335	340	345	350			
0.00-0.04		2.30	2.35	2.40	2.45	2.50	2.55	2.60	2.65	2.70	2.75	2.80	2.85	2.90	2.95	3.00	3.05	3.10	3.15	3.20	3.25	3.30	3.35	3.40	3.45	3.50			
0.05-0.09		2.30	2.35	2.40	2.45	2.50	2.55	2.60	2.65	2.70	2.75	2.80	2.85	2.90	2.95	3.00	3.05	3.10	3.15	3.20	3.25	3.30	3.35	3.40	3.45	3.50			
0.10-0.20		2.40	2.45	2.50	2.55	2.60	2.65	2.70	2.75	2.80	2.85	2.90	2.95	3.00	3.05	3.10	3.15	3.20	3.25	3.30	3.35	3.40	3.45	3.50	3.50				
0.21-0.25		2.45	2.50	2.55	2.60	2.65	2.70	2.75	2.80	2.85	2.90	2.95	3.00	3.05	3.10	3.15	3.20	3.25	3.30	3.35	3.40	3.45	3.50	3.50					
0.26-0.30		2.45	2.50	2.55	2.60	2.65	2.70	2.75	2.80	2.85	2.90	2.95	3.00	3.05	3.10	3.15	3.20	3.25	3.30	3.35	3.40	3.45	3.50	3.50					
0.31-0.35		2.50	2.55	2.60	2.65	2.70	2.75	2.80	2.85	2.90	2.95	3.00	3.05	3.10	3.15	3.20	3.25	3.30	3.35	3.40	3.45	3.50	3.50						
0.36-0.40		2.55	2.60	2.65	2.70	2.75	2.80	2.85	2.90	2.95	3.00	3.05	3.10	3.15	3.20	3.25	3.30	3.35	3.40	3.45	3.50	3.50							
0.41-0.45		2.60	2.65	2.70	2.75	2.80	2.85	2.90	2.95	3.00	3.05	3.10	3.15	3.20	3.25	3.30	3.35	3.40	3.45	3.50	3.50								
0.46-0.50		2.65	2.70	2.75	2.80	2.85	2.90	2.95	3.00	3.05	3.10	3.15	3.20	3.25	3.30	3.35	3.40	3.45	3.50	3.50									
0.51-0.55		2.70	2.75	2.80	2.85	2.90	2.95	3.00	3.05	3.10	3.15	3.20	3.25	3.30	3.35	3.40	3.45	3.50	3.50										
0.56-0.60		2.75	2.80	2.85	2.90	2.95	3.00	3.05	3.10	3.15	3.20	3.25	3.30	3.35	3.40	3.45	3.50	3.50											
0.61-0.65		2.80	2.85	2.90	2.95	3.00	3.05	3.10	3.15	3.20	3.25	3.30	3.35	3.40	3.45	3.50	3.50												
0.66-0.70		2.85	2.90	2.95	3.00	3.05	3.10	3.15	3.20	3.25	3.30	3.35	3.40	3.45	3.50	3.50													
0.71-0.75		2.90	2.95	3.00	3.05	3.10	3.15	3.20	3.25	3.30	3.35	3.40	3.45	3.50	3.50														
0.76-0.80		2.95	3.00	3.05	3.10	3.15	3.20	3.25	3.30	3.35	3.40	3.45	3.50	3.50															
0.81-0.85		3.00	3.05	3.10	3.15	3.20	3.25	3.30	3.35	3.40	3.45	3.50	3.50																
0.86-0.90		3.05	3.10	3.15	3.20	3.25	3.30	3.35	3.40	3.45	3.50	3.50																	
0.91-0.95		3.10	3.15	3.20	3.25	3.30	3.35	3.40	3.45	3.50	3.50																		
0.96-1.00		3.15	3.20	3.25	3.30	3.35	3.40	3.45	3.50	3.50																			
1.01-1.05		3.20	3.25	3.30	3.35	3.40	3.45	3.50	3.50																				
1.06-1.10		3.25	3.30	3.35	3.40	3.45	3.50	3.50																					
1.11-1.15		3.30	3.35	3.40	3.45	3.50	3.50																						
1.16-1.20		3.35	3.40	3.45	3.50	3.50																							
1.21-1.25		3.40	3.45	3.50	3.50																								
1.26-1.30		3.45	3.50	3.50																									
1.31-1.35		3.50	3.50																										
1.36-1.40		3.50																											

How to use this chart:

- I. Measure tappet clearance when the engine is cold.
- II. Measure present shim size.
- III. Match clearance in vertical column with present shim size in horizontal column.

Example:

- Tappet clearance is 0.23 mm
- Present shim size 2.70 mm
- Shim size to be used 2.80 mm



Testing Engine Compression

To test engine compression, use the following procedure.

1. Remove the high tension lead from the spark plug.
2. Using compressed air, blow any debris from around the spark plug.

WARNING

Always wear safety glasses when using compressed air.

3. Remove the spark plug; then attach the high tension lead to the plug and ground the plug on the cylinder head well away from the spark plug hole.
4. Attach the Compression Gauge (p/n 0444-096).

■**NOTE:** The engine must be warm and the battery must be fully charged for this test.

5. While holding the throttle lever in the full-open position, crank the engine over with the electric starter until the gauge shows a peak reading (five to 10 compression strokes). The compression should be 10.0 kg/cm² (142 psi).
6. If compression is abnormally low, inspect the following items.
 - A. Verify starter cranks engine over at normal cranking speed.
 - B. Gauge is functioning properly.
 - C. Throttle lever in the full-open position.
 - D. Valve/tappet clearance correct.
 - E. Valve bent or burned.
 - F. Valve seat burned.

■**NOTE:** To service valves, see Section 3.

7. Pour 29.5 ml (1 fl oz) of oil into the spark plug hole, reattach the gauge, and retest compression.
8. If compression is now evident, service the piston rings (see Section 3).

Spark Plug

A light brown insulator indicates that the plug is correct. A white or dark insulator indicates that the engine may need to be serviced or the carburetor may need to be adjusted. To maintain a hot, strong spark, keep the plug free of carbon.

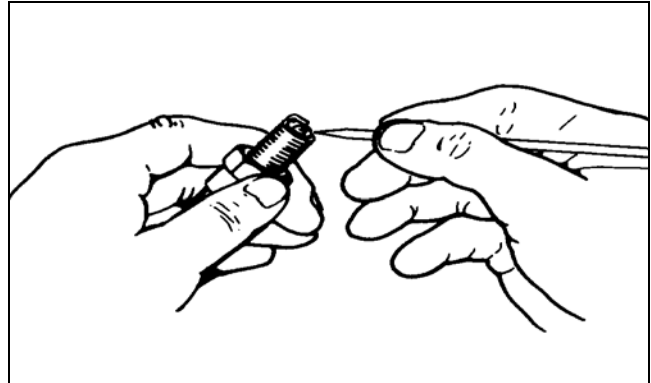

ATV-0051

CAUTION

Before removing the spark plug, be sure to clean the area around the spark plug. Dirt could enter engine when removing or installing the spark plug.

Adjust the gap to 0.7-0.8 mm (0.028-0.032 in.). Use a feeler gauge to check the gap.

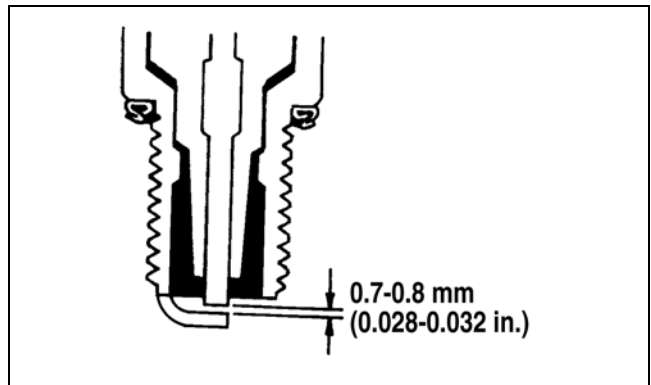

ATV0052C

When installing the spark plug, tighten to specifications (see Section 10).

Muffler/Spark Arrester

The muffler has a spark arrester which must be periodically cleaned. At the intervals shown in the Periodic Maintenance Chart, clean the spark arrester using the following procedure.

WARNING

Wait until the muffler cools to avoid burns.

1. Remove the three Allen-head cap screws securing the spark arrester to the muffler; then remove the spark arrester.



SP001

2. Use a wire brush to remove carbon deposits from the arrester taking care not to damage the screen.

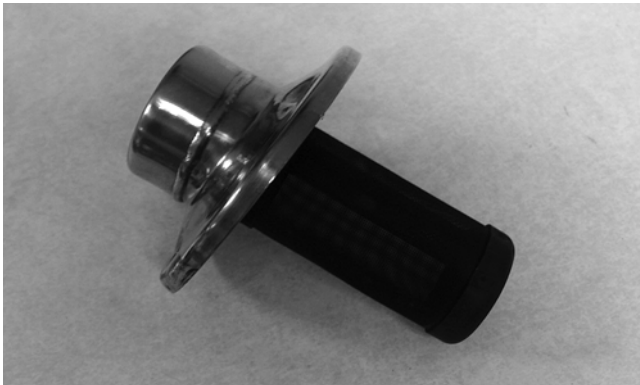

SP041

3. Check the arrester screen for holes or tears and replace components as necessary.
4. Install the spark arrester and three cap screws and tighten securely.

Gas/Vent Hoses

Replace the gas hose every two years. Damage from aging may not always be visible. Do not bend or obstruct the routing of the carburetor vent hose. Make certain that the vent hose is securely connected to the carburetor and the opposite end is always open.

Adjusting Throttle Cable

To adjust the throttle cable free-play, follow this procedure.

1. Slide the rubber boot away; then loosen the jam nut from the throttle cable adjuster.

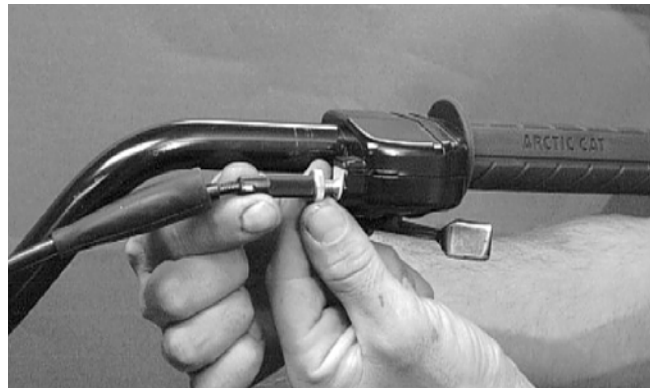

AL611D

2. Slide the rubber boot away and turn the adjuster until the throttle cable has proper free-play of 3-5 mm (1/8-1/5 in.) at the lever.

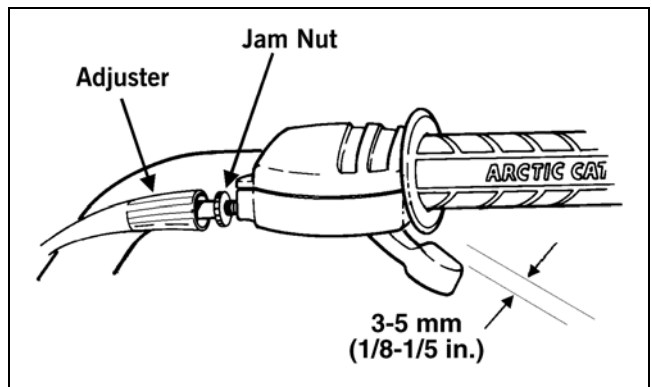

ATV-0047A

3. Tighten the jam nut against the throttle cable adjuster securely; then slide the rubber boot over the adjuster.

Adjusting Engine RPM (Idle)

To properly adjust the idle RPM, a tachometer is necessary. To adjust idle RPM, use the following procedure.

1. With the transmission in neutral, start the engine and warm it up to normal operating temperature.
2. Turn the idle adjustment screw (on the left side of the carburetor) clockwise one turn past the recommended RPM setting; then turn it counterclockwise to 1400-1600 RPM.

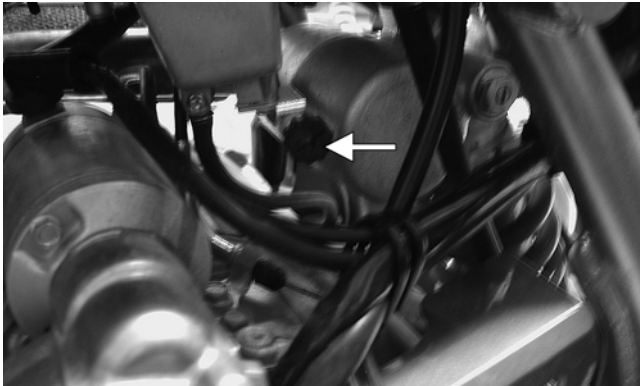

SP008A

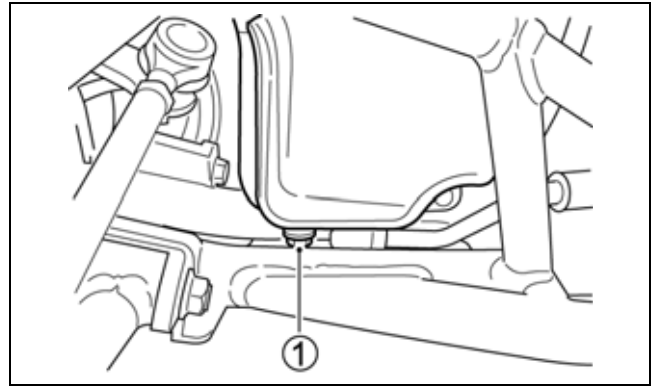

ATV2027

⚠ WARNING

Adjust the idle to the correct RPM. Make sure the engine is at normal operating temperature before adjusting the idle RPM.

Engine/Transmission Oil - Filter

OIL - FILTER

Change the engine oil and oil filter at the scheduled intervals. The engine should always be warm when the oil is changed so the oil will drain easily and completely.

1. Park the ATV on level ground.
2. Loosen the oil level stick enough to allow air to vent the tank.



SP016A

3. Place drain pans under the oil tank drain plug (1) and the crankcase drain plug (2); then remove the plugs and drain the oil.

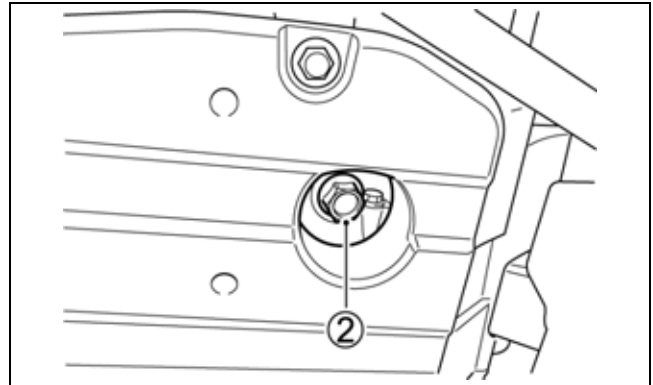

ATV2028

4. Remove the cap screws securing the filter cover.
5. Remove the filter cover (3); then pull out the oil filter element (4) and properly discard. Remove and properly discard the O-ring from the filter cover.

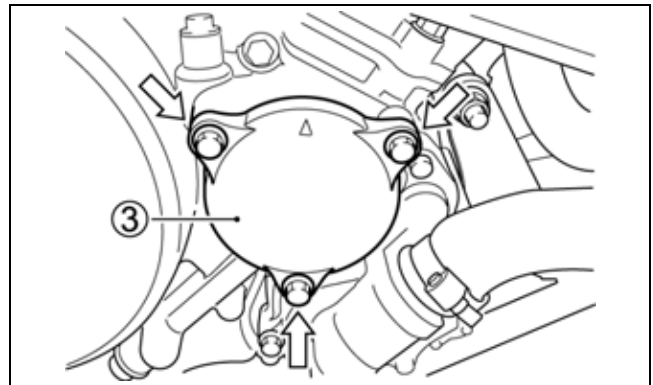

ATV2029

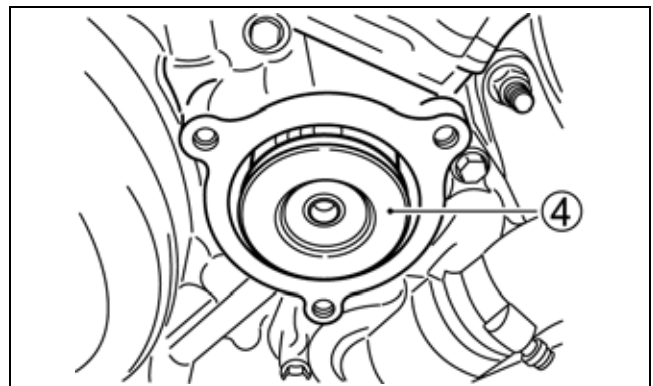

ATV2030

■NOTE: Clean up any excess oil after removing the filter.

- Apply oil to a new cover O-ring and check to make sure it is positioned correctly in the cover. With the open end of the filter element directed toward the center of the engine, slide the element into position.

CAUTION

If the oil filter element is inserted backwards, engine damage will occur due to lack of oil flow.

- Place the filter cover in position with the triangle mark up and secure with the cap screws. Tighten securely.
- Install the crankcase drain plug and tighten to specifications; then install the oil tank drain plug and tighten to specifications (see Section 10).
- Pour the recommended type and quantity of oil (see Section 1) into the oil level stick hole; then start the engine (while the ATV is outside on level ground) and allow it to idle for a few minutes.
- Turn the engine off and wait approximately one minute. Check the oil level with the oil level stick. The oil level should be between the upper and lower crosshatch marks on the level stick. Adjust oil level as necessary.

■NOTE: The oil level stick should not be threaded into the oil tank for checking purposes.

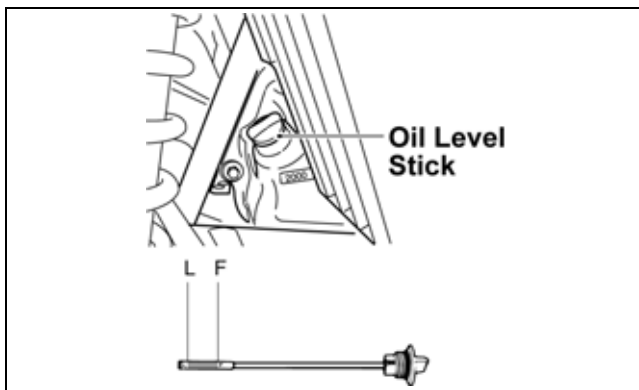

- Inspect the area around the drain plugs and oil filter for leaks.

Adjusting Clutch Lever Cable

To adjust the cable, use the following procedure.

- Pull rubber protective boot away from the cable adjusters.

- Loosen the lock nut; then turn the adjuster to obtain 10-15 mm (0.4-0.6 in.) free-play measured at point (A).

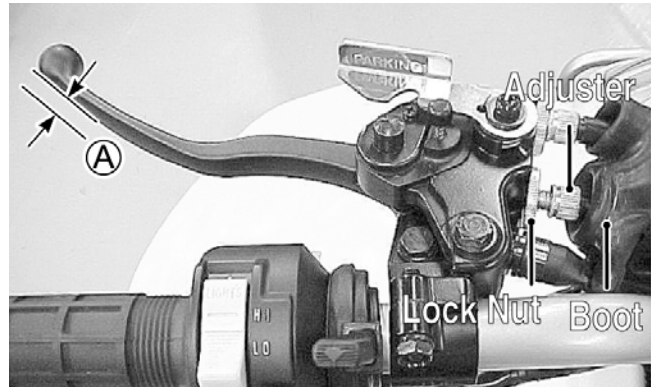

Tires

TIRE SIZES

The ATV is equipped with low-pressure tubeless tires of the size and type listed. Do not under any circumstances substitute tires of a different type or size (see Section 1).

WARNING

Always use the size and type of tires specified. Always maintain proper tire inflation pressure.

TIRE INFLATION PRESSURE

Front and rear tire inflation pressure should be at recommended specifications (see Section 1).

A low-pressure gauge is provided in the tool kit to measure the air pressure in the tires. Check the air pressure in all tires before each use of the ATV.

Steering Components

The following steering components should be inspected periodically to ensure safe and proper operation.

- Handlebar grips not worn, broken, or loose.
- Handlebar not bent, cracked, and has equal and complete full-left and full-right capability.
- Steering post bearing assembly/bearing housing not broken, worn, or binding.
- Ball joints not worn, cracked, or damaged.
- Tie rods not bent or cracked.

- F. Knuckles not worn, cracked, or damaged.
- G. Cotter pins not damaged or missing.

Suspension/Shock Absorbers/Bushings

The following suspension system components should be inspected periodically to ensure proper operation.

- A. Shock absorber rods bent, pitted, or damaged.
- B. Rubber damper cracked, broken, or missing.
- C. Shock absorber body damaged, punctured, or leaking.
- D. Shock absorber eyelets broken, bent, or cracked.
- E. Shock absorber eyelet bushings worn, deteriorated, cracked, or missing.
- F. Shock absorber spring broken or sagging.

Nuts/Bolts/Cap Screws

Tighten all nuts, bolts, and cap screws. Make sure rivets holding components together are tight. Replace all loose rivets. Care must be taken that all calibrated nuts, bolts, and cap screws are tightened to specifications. For proper torque values, see Section 10.

Headlight/Taillight-Brakelight

Each time the ATV is used, lights should be checked for proper function. Rotate the ignition switch to the lights position; the headlights and taillight should illuminate. Test the brakelight by compressing the brake lever. The brakelight should illuminate.

HEADLIGHT

■NOTE: The bulb portion of the headlight is fragile. HANDLE WITH CARE. When replacing the headlight bulb, do not touch the glass portion of the bulb. If the glass is touched, it must be cleaned with a dry cloth before installing. Skin oil residue on the bulb will shorten the life of the bulb.

⚠ WARNING

Do not attempt to remove the bulb when it is hot. Severe burns may result.

To replace the headlight bulb, use the following procedure.

1. Turn the bulb counterclockwise; then remove from the reflector housing.
2. Disconnect the two-wire connector from the bulb; then connect the new bulb to the connector.
3. Install the bulb into the reflector housing and turn the bulb clockwise to lock.

TAILLIGHT-BRAKELIGHT

To replace the taillight-brakelight bulb, use the following procedure.

1. Twist the socket counterclockwise to remove it from the taillight housing.



SP089

2. Pull the bulb straight out of the socket; then install the new bulb.



SP085

3. Install the socket in the taillight housing by pushing in and turning clockwise.

⚠ CAUTION

Tighten the lens cover screws only until they are snug.

CHECKING/ADJUSTING HEADLIGHT AIM

The headlights can be adjusted vertically and horizontally. The geometric center of the HIGH beam light zone is to be used for vertical and horizontal aiming.

1. Position the ATV on a level floor so the headlights are approximately 6.1 m (20 ft) from an aiming surface (wall or similar aiming surface).

■**NOTE:** There should be an average operating load on the ATV when adjusting the headlight aim.

2. Measure the distance from the floor to the mid-point of each headlight.
3. Using the measurements obtained in step 2, make horizontal marks on the aiming surface.
4. Make vertical marks which intersect the horizontal marks on the aiming surface directly in front of the headlights.
5. Switch on the lights. Make sure the HIGH beam is on. DO NOT USE LOW BEAM.
6. Observe each headlight beam aim. Proper aim is when the most intense beam is centered on the vertical mark 5 cm (2 in.) below the horizontal mark on the aiming surface.

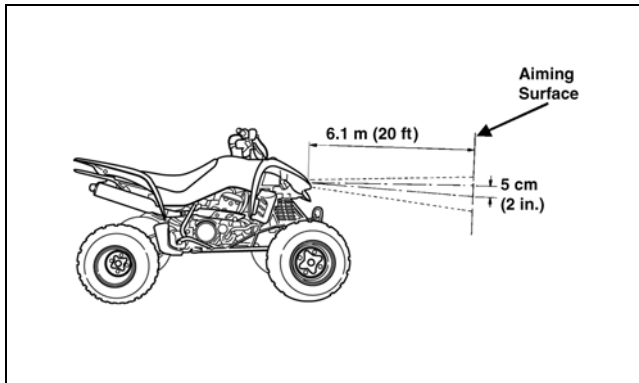

ATV2051B

7. Adjust the headlight assembly until correct aim is obtained.

- A. Loosen the adjuster nut; then move the stud up or down in the slot until proper aim is obtained.
- B. Tighten the adjuster nut securely.

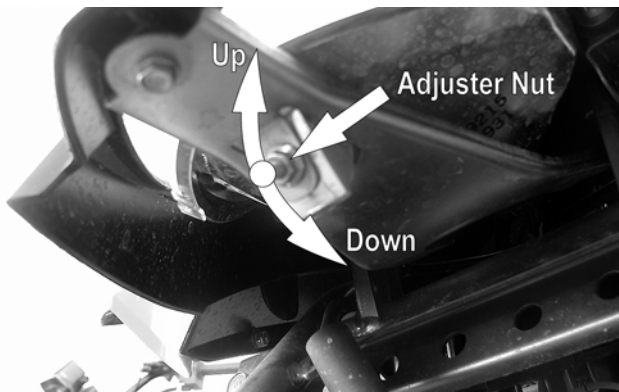

CD839

Switches

Each time the ATV is used, switches should be checked for proper operation. Use the following list for reference.

- A. Ignition switch — engine will start.
- B. Emergency stop switch — engine will stop.
- C. Reverse switch — reverse indicator light illuminates.
- D. Hi/Lo switch — headlight beam bright and dim.
- E. Brake switches — rear brakelight illuminates.
- F. Neutral switch — neutral indicator light illuminates when transmission is in neutral.

Indicator Lights

Each time the ATV is used, the lights should be checked for proper function. Use the following for reference.

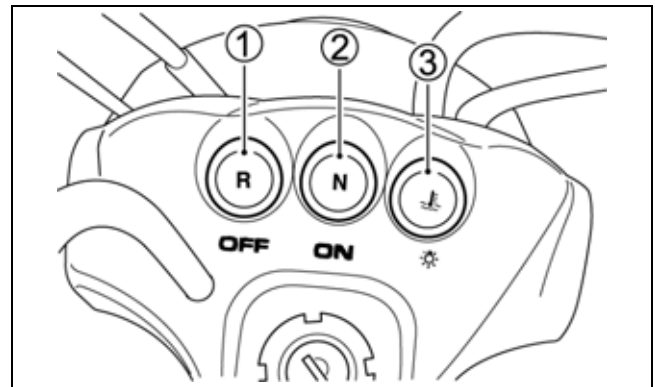

ATV2007

1. **Reverse Indicator** — A red light will illuminate when the transmission is shifted into reverse gear. The light will go off when shifted out of reverse.
2. **Neutral Indicator** — A green light will illuminate when the transmission is in neutral and the ignition switch is on. The light will go out when shifted into any gear other than neutral.
3. **Water Temperature Indicator** — A red light will illuminate if the engine overheats. The light should be off during normal operation.

Frame/Welds

The frame and welds should be checked periodically for damage, bends, cracks, deterioration, broken components, and missing components. If replacement or repair constitutes removal, see Section 8.

Electrical Connections

The electrical connections should be checked periodically for proper function. In case of an electrical failure, check fuse, connections (for tightness, corrosion, damage), and/or bulbs. If an electrical component needs to be tested for proper function, see Section 5.

Hydraulic/Parking Brake Systems

CHECKING/BLEEDING

The hydraulic brake systems have been filled and bled at the factory. To check and/or bleed a hydraulic brake system, use the following procedure.

1. With the front brake master cylinder in a level position, check the fluid level in the reservoir. If the level in the reservoir is not visible in the sight glass, add DOT 4 brake fluid.

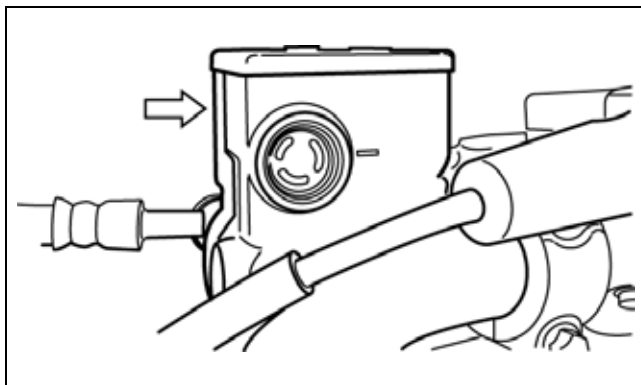

ATV2037

2. Compress the brake lever several times to check for a firm brake. If the brake is not firm, the front brake system must be bled.
3. Remove the rear brake reservoir cap. If the level in the reservoir is not above the mark, add DOT 4 brake fluid.

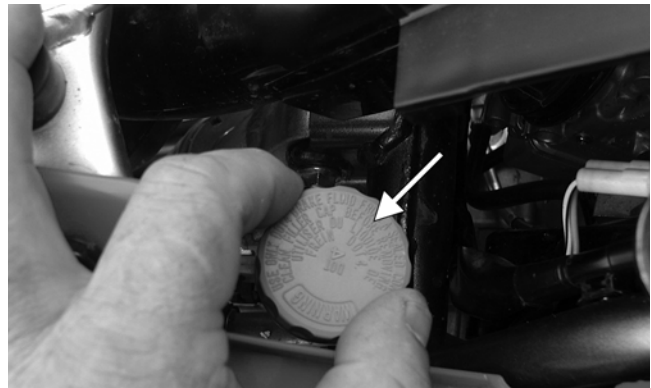

SP111A

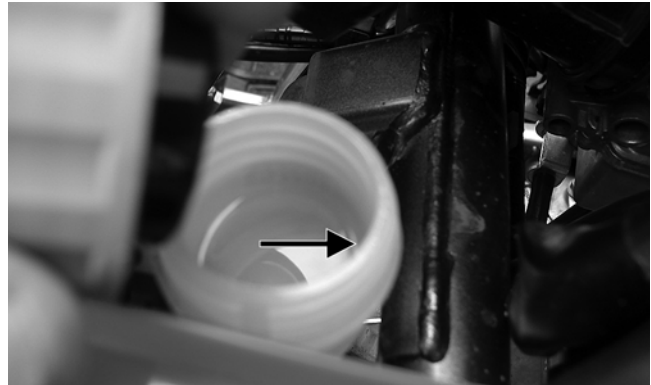

SP112A

4. Depress the brake pedal several times to check for a firm pedal. If the pedal is not firm, the rear brake system must be bled.

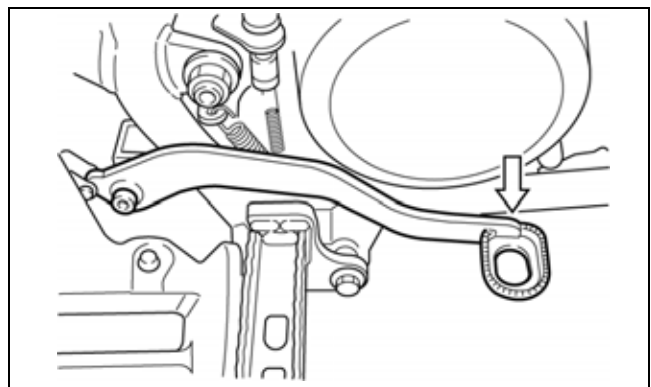

ATV2009

5. To bleed the front brake system, use the following procedure.
 - A. Remove the cover and fill the reservoir with DOT 4 Hi-Temp Brake Fluid.



SP028

- B. Install and secure the cover; then slowly compress the brake lever several times.
- C. Remove the protective cap, install one end of a clear hose onto one FRONT bleeder screw, and direct the other end into a container; then while holding slight pressure on the brake lever, open the bleeder screw and watch for air bubbles. Close the bleeder screw before releasing the brake lever. Repeat this procedure until no air bubbles are present.



AF637D

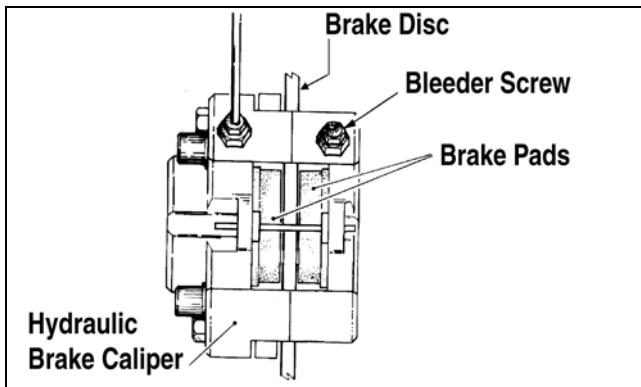

730-434B

■NOTE: During the bleeding procedure, watch the reservoir sight glass very closely to make sure there is always a sufficient amount of brake fluid. Failure to maintain a sufficient amount of fluid in the reservoir will result in air in the system.

- D. Repeat step C until no air bubbles are observed in the bleeder line. Close the bleeder screw and tighten

- E. Perform steps B, C, and D on the other FRONT bleeder screw repeating step C until no air bubbles are observed in the bleeder line. Make sure that the brake lever is firm.

■NOTE: If the brake lever is still not firm, it may be necessary to do the entire front brake bleeding procedure over.

- 6. To bleed the rear brake system, use the following procedure.
 - A. Remove the rear brake reservoir cap and fill the reservoir with DOT 4 Hi-Temp Brake Fluid.
 - B. Install and tighten the cover; then depress the brake pedal several times.
 - C. Remove the protective cap, install one end of a clear hose on the REAR bleeder screw, and direct the other end into a container; then while holding slight pressure on the brake pedal, open the bleeder screw and watch for air bubbles. Close the bleeder screw before releasing the brake pedal. Repeat this procedure until no air bubbles are present.
 - D. Repeat step C until the brake pedal is firm.
- 7. Carefully inspect the hydraulic brake hoses for cracks or other damage. If found, the brake hoses must be replaced.

CAUTION

This hydraulic brake system is designed to use high-temperature DOT 4 brake fluid only. If brake fluid must be added, care must be taken as brake fluid is very corrosive to painted surfaces.

INSPECTING HOSES

Carefully inspect the hydraulic brake hoses for cracks or other damage. If found, the brake hoses must be replaced.

MEASURING/REPLACING FRONT BRAKE PADS

The clearance between the brake pads and brake discs is adjusted automatically as the brake pads wear. The only maintenance that is required is replacement of the brake pads when they show excessive wear. Check the thickness of each of the brake pads as follows.

- 1. Remove the front wheels.
- 2. Measure the thickness of each brake pad.

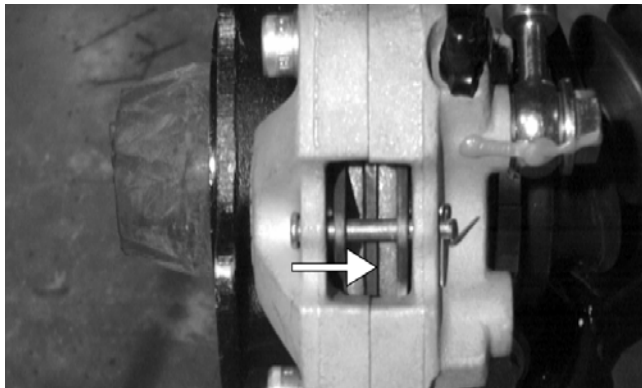

AF739DB

3. If thickness of any brake pad is less than 2.0 mm (0.078 in.), all brake pads must be replaced.

■NOTE: The brake pads should be replaced as a complete set.

4. To replace the brake pads, use the following procedure.

A. Remove the caliper mounting cap screws (1) and the brake pad mounting pins (2); then remove the brake pads. Account for the shims.

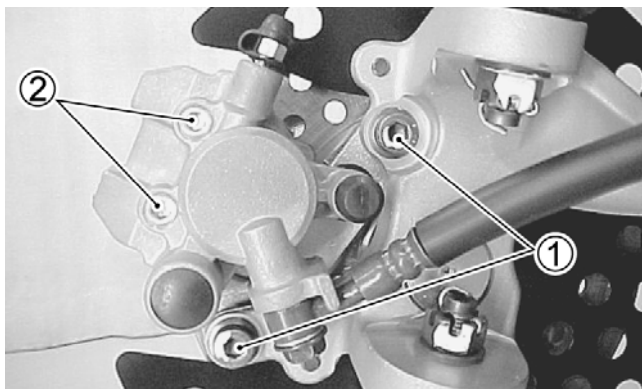

SP127

■NOTE: Do not compress the brake lever after the brake pads are removed.

■NOTE: Inspect the brake pad mounting pins (2) for wear. If excessive wear is found, the pins must be replaced.

■NOTE: The shim must be installed on the piston side brake pad.

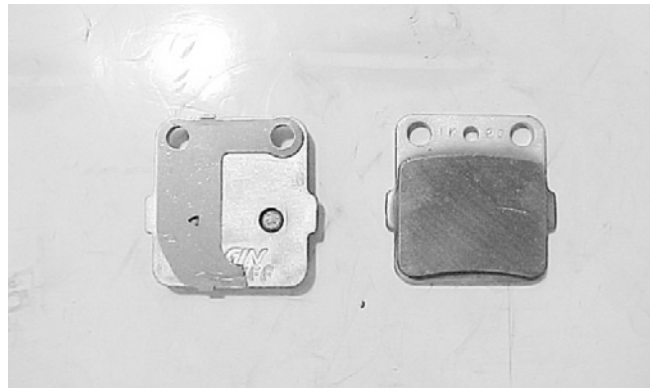

SP128

■NOTE: Make sure the detent of the brake pad is fitted to the recess on the brake caliper bracket.

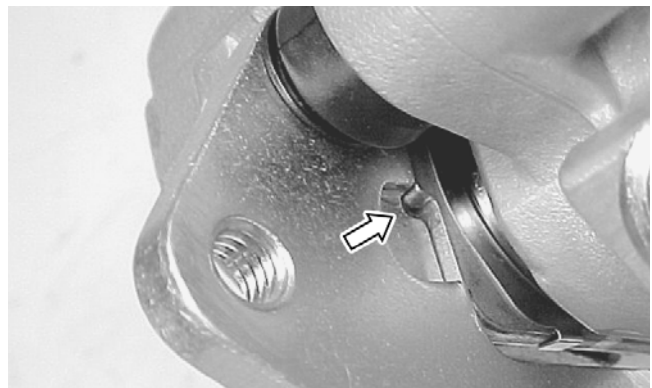

SP129

B. Install the new brake pads; then tighten the brake pad mounting pins and the brake caliper mounting cap screws to specifications (see Section 10).

■NOTE: After replacing the brake pads, compress the brake lever several times to check for proper brake operation; then check the brake fluid level.

C. Install the wheels and tighten to specifications (see Section 10) using the pattern shown.

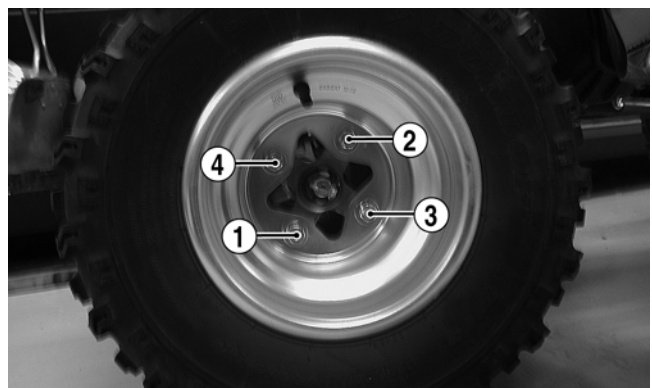

SP018A

5. Burnish the brake pads (see Burnishing Brake Pads in this section).

MEASURING/REPLACING REAR BRAKE PADS

1. Release the parking brake, if applied; then remove two cap screws securing the brake caliper assembly to the rear housing.

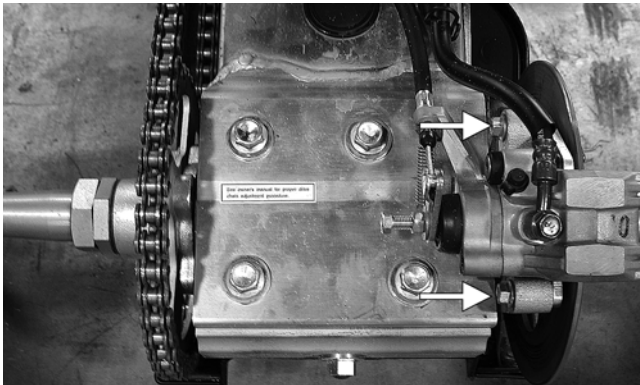

SP061C

■NOTE: Do not depress the brake pedal as this will push the piston out spilling brake fluid. The rear brake system will have to be refilled and bled if this occurs.

2. Bend down the locking tabs (A) on the washer and remove the brake pad mounting pins (B); then remove the brake pads.

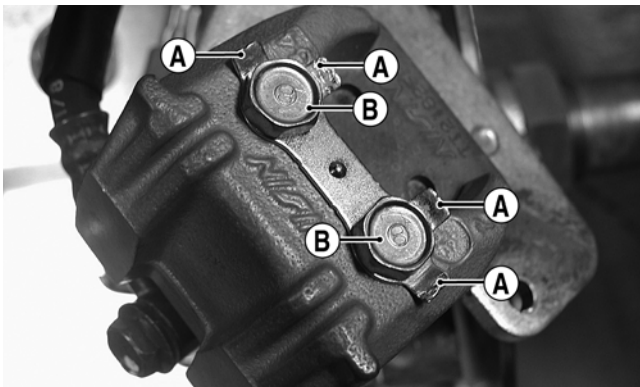

SP114A



SP116

3. Inspect the pads for gouges, chips, or wear.
4. Inspect the disc for gouges, grooves, cracks, and warpage.

5. Using a calipers, measure the thickness of each brake pad.

6. If the thickness of any brake pad is less than 2.0 mm (0.078 in.), all brake pads must be replaced.

■NOTE: The brake pads should be replaced as a complete set.

7. Using compressed air, blow dust and brake pad residue from the caliper; then install new brake pads and secure with the two mounting pins. Tighten to specifications (see Section 10) and lock with the tabs on the washer.

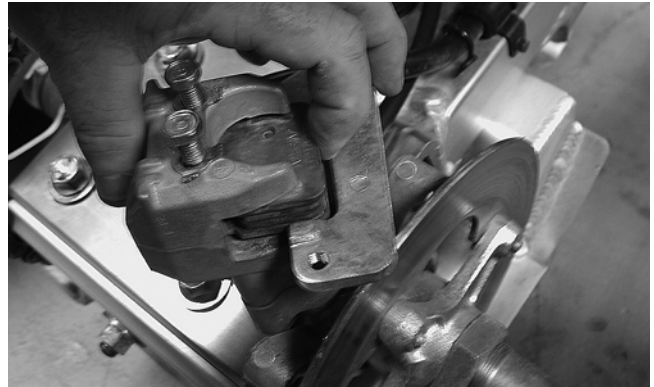

SP117

8. Carefully separate the brake pads to allow the assembly to slip over the rotor; then install and secure to the rear housing with the two cap screws. Tighten to specifications (see Section 10).

■NOTE: It may be necessary to loosen the parking brake adjuster screws in order to open the pads sufficiently to clear the rotor. Anytime the rear brake pads are replaced, the parking brake MUST be adjusted.

ADJUSTING PARKING BRAKE

To adjust the parking brake, use the following procedure.

1. Loosen the parking brake adjuster lock nut (1) while holding the adjuster (2) with a screwdriver; then turn the adjuster counterclockwise several turns.

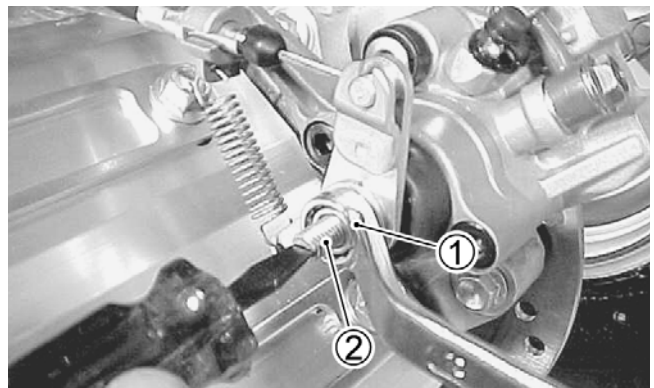

SP130

- Loosen the parking brake cable adjuster (3) and turn the adjuster (4) to achieve a cable length of 47-51 mm (1.9-2.0 in.) at (A).

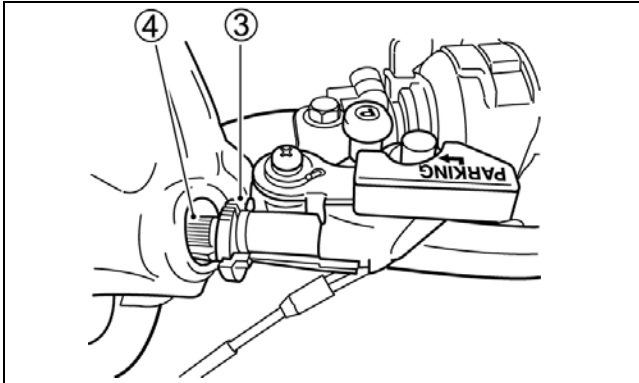

ATV2154

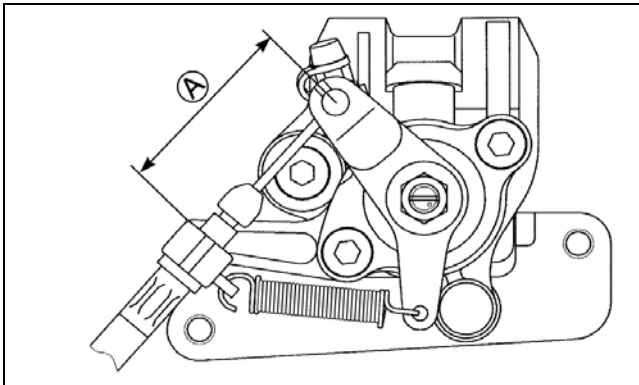

ATV2155

- Tighten the cable adjuster lock nut (3) securely.
- Turn the parking brake adjuster screw (2) clockwise until it stops; then back up adjuster 1/8-1/4 turn.
- Hold the adjuster screw (2) in position and tighten the lock nut (1) to specifications (see Section 10).

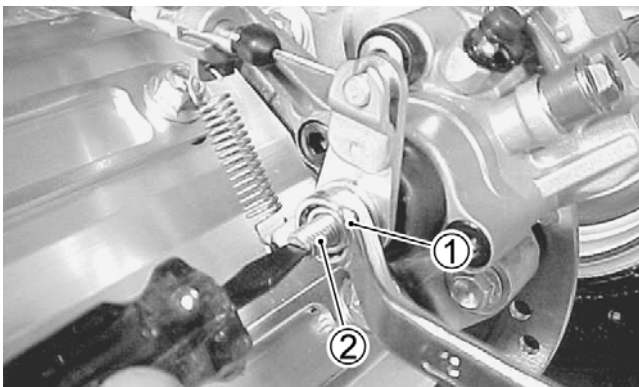

SP130

■NOTE: Check that rear wheels turn freely when the parking brake is released and that they lock when the parking brake is engaged and locked.

Burnishing Brake Pads

Brake pads (both hydraulic and auxiliary) must be burnished to achieve full braking effectiveness. Braking distance will be extended until brake pads are properly burnished. To properly burnish the brake pads, use the following procedure.

⚠ WARNING

Failure to properly burnish the brake pads could lead to premature brake pad wear or brake loss. Brake loss can result in severe injury.

- Choose an area large enough to safely accelerate the ATV to 30 mph and to brake to a stop.
- Accelerate to 30 mph; then compress brake lever or apply the auxiliary brake to decelerate to 0-5 mph.
- Repeat procedure on each brake system five times until brake pads are burnished.
- Adjust the parking brake (if necessary).
- Verify that the brakelight illuminates when the hand lever is compressed or the brake pedal is depressed.

2

Coolant

When filling the cooling system, use premixed Arctic Cat Antifreeze. While the cooling system is being filled, air pockets may develop; therefore, run the engine for five minutes after the initial fill, shut the engine off, and then fill the cooling system to the bottom of the stand pipe in the radiator neck. Make sure the coolant level in the overflow tank is between the upper and lower marks.

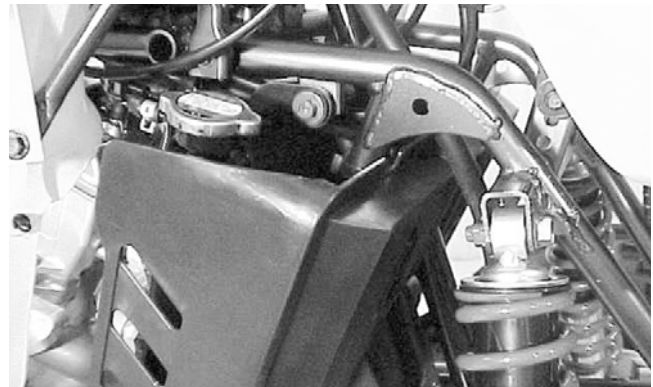

SP131

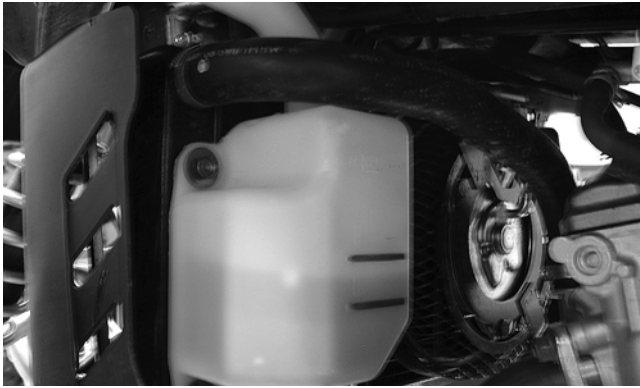

SP019

⚠ CAUTION

After operating the ATV for the initial 5-10 minutes, stop the engine, allow the engine to cool down, and check the coolant level. Add coolant as necessary.

Drive Chain

INSPECTING

To properly check the drive chain for defects, support the ATV with a jack or suitable block under the swing arm allowing the rear wheels to turn freely. With the transmission in neutral, slowly rotate the wheels and inspect the drive chain for the following items:

1. Loose Pins
2. Damaged Rollers
3. Dry or Rusted Links
4. Kinked or Binding Links
5. Excessive Wear
6. Improper Adjustment
7. Missing O-Ring Seals

MEASURING

1. Loosen the four cap screws on top of the swing arm; then turn the adjuster nut clockwise until all slack is out of the chain.

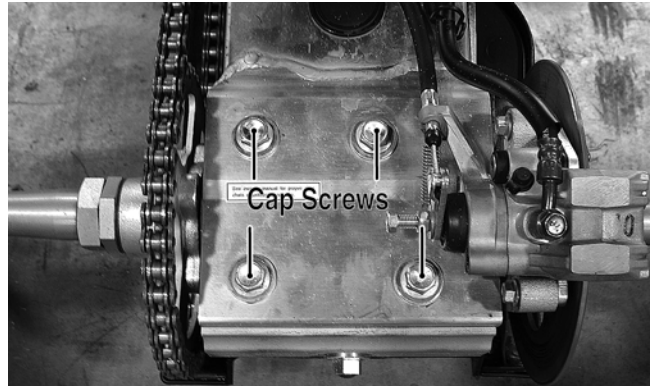

SP061A

2. Count out 21 pins on the chain and measure the distance between the two points. If this distance exceeds the service limit of 31.94 cm (12.57 in.), the chain must be replaced.

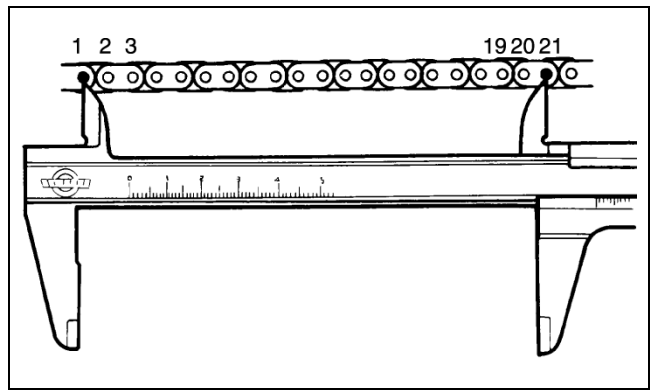

ATV2156

ADJUSTING

To adjust the drive chain, use the following procedure.

1. Loosen the four cap screws on the top of the swing arm; then turn the adjuster nut until the chain has 30-40 mm (1.2-1.6 in.) slack midway between the chain buffer and the rear sprocket.

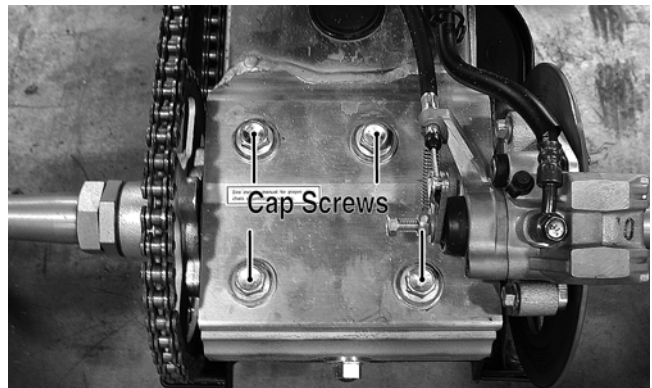

SP061A

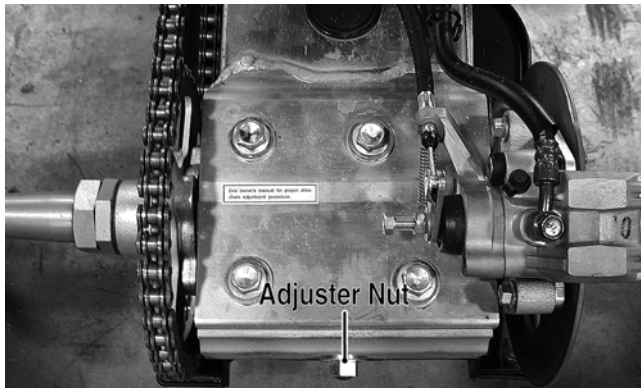

SP061B

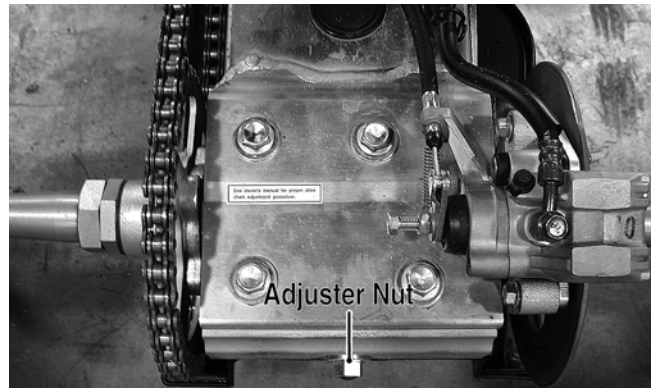

SP061B

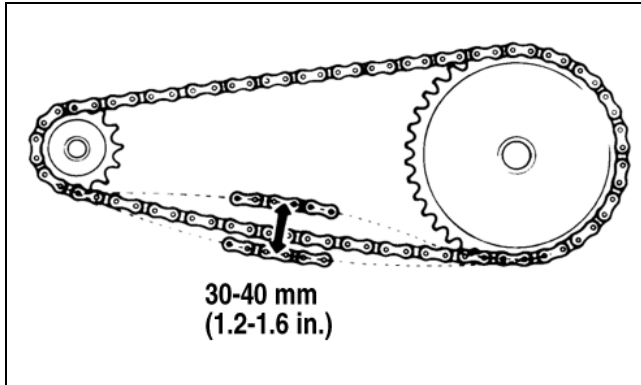

ATV2157

2. Tighten the four cap screws to specifications (see Section 10) and recheck the chain tension.

REPLACING

■NOTE: When replacing the drive chain, replace the chain and sprockets as a set.

1. Place the ATV on a level surface and block the front wheels; then raise the rear end and place support under the axle housing.
2. Remove the left-rear wheel; then remove the cotter pin, hub nut, flat washer, and the hub.
3. Loosen the four cap screws on top of the swing arm; then slacken the chain by turning the adjuster nut counterclockwise.

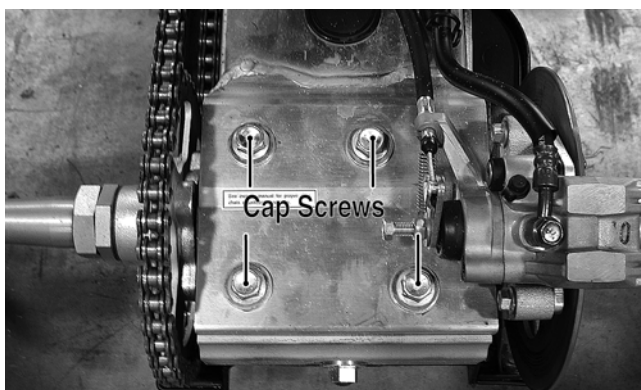

SP061A

4. Locate and remove the master link (chain connector link); then remove the drive chain.
5. Remove the four cap screws securing the driven sprocket to the sprocket hub; then remove the sprocket from the axle.
6. Remove the two cap screws securing the drive sprocket cover; then remove the cover.

2

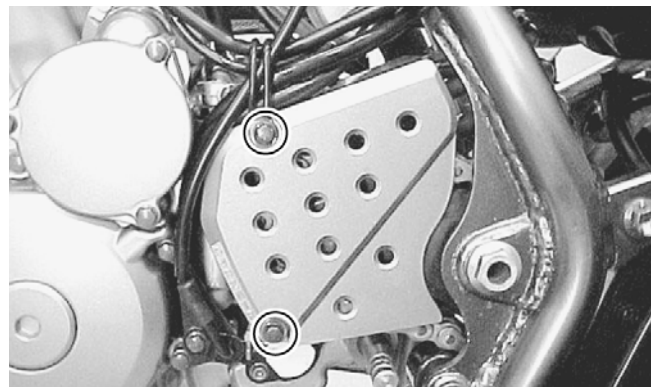

SP134

7. Remove the drive sprocket cap screws and remove the sprocket.
8. Install a new drive sprocket; then apply red Loctite #271 to the drive sprocket cap screws and tighten to specifications (see Section 10).
9. Install a new driven sprocket; then apply red Loctite #271 to the sprocket mounting cap screws and tighten to specifications (see Section 10).
10. Install a new chain and adjust (see Adjusting in this sub-section).
11. Install the drive sprocket cover and tighten securely.
12. Lightly lubricate the axle spline with multipurpose grease; then install the hub, flat washer, and the hub nut and tighten to specifications (see Section 10).

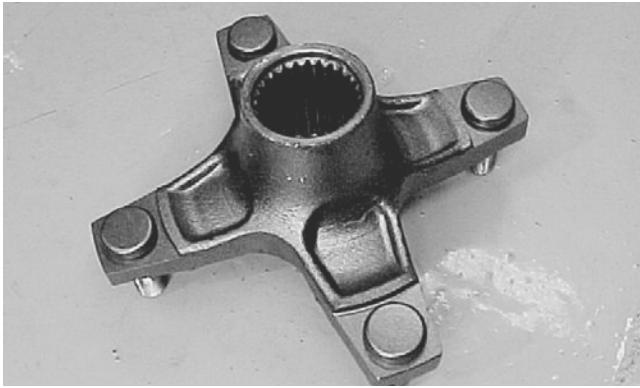

SP136

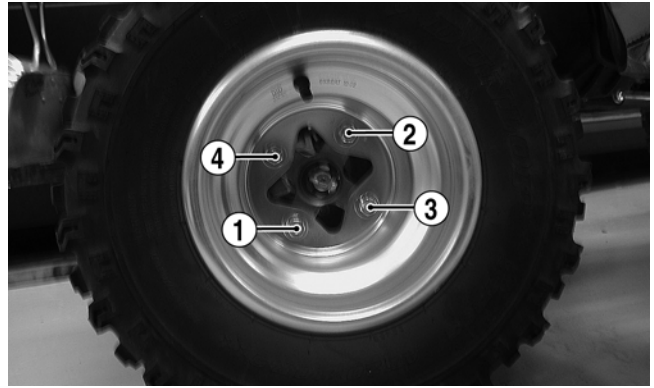

SP018A

13. Install a new cotter pin; then install the wheel and tighten the lug nuts to specifications (see Section 10) using the pattern shown.

SECTION 3 - ENGINE/TRANSMISSION

TABLE OF CONTENTS

Engine/Transmission	3-2
Specifications	3-2
Table of Contents (DVX 400).....	3-3

Engine/Transmission

This section has been organized into sub-sections which show a progression for the complete servicing of the Arctic Cat ATV engine/transmission.

To service the center crankcase halves, the engine/transmission must be removed from the frame.

To service top-side, left-side, and right-side components, the engine/transmission does not have to be removed from the frame.

■NOTE: Arctic Cat recommends the use of new gaskets, lock nuts, and seals and lubricating all internal components when servicing the engine/transmission.

■NOTE: Some photographs and illustrations used in this section are used for clarity purposes only and are not designed to depict actual conditions.

Specifications

VALVES AND GUIDES

Valve Face Diameter	(intake)	36 mm (1.4 in.)
	(exhaust)	29 mm (1.1 in.)
Valve/Tappet Clearance (cold engine)	(intake)	0.10-0.20 mm (0.0039-0.0078 in.)
	(exhaust)	0.20-0.30 mm (0.0078-0.0118 in.)
Valve Guide/Stem Clearance	(intake)	0.010-0.037 mm (0.0004-0.0015 in.)
	(exhaust)	0.030-0.057 mm (0.0012-0.0024 in.)
Valve Guide/Valve Stem Deflection (wobble method)	(max)	0.35 mm (0.014 in.)
Valve Guide Inside Diameter		5.000-5.012 mm (0.1968-0.1973 in.)
Valve Stem Outside Diameter	(intake)	4.975-4.990 mm (0.1959-0.1965 in.)
	(exhaust)	4.955-4.970 mm (0.1951-0.1957 in.)
Valve Stem Runout	(max)	0.05 mm (0.002 in.)
Valve Head Thickness	(min)	0.5 mm (0.02 in.)
Valve Face/Seat Width		0.9-1.1 mm (0.035-0.043 in.)
Valve Seat Angle	(intake)	45°
	(exhaust)	45°
Valve Face Radial Runout	(max)	0.03 mm (0.001 in.)
Valve Spring Free Length	(max)	38.8 mm (1.53 in.)
Valve Spring Tension @ 36.0 mm (1.42 in.)		18.6-21.4 kg (41.0-47.2 lb)

CAMSHAFT AND CYLINDER HEAD

Cam Lobe Height (min)	(intake)	36.020 mm (1.418 in.)
	(exhaust)	34.900 mm (1.374 in.)
Camshaft Journal Oil Clearance (max)		0.15 mm (0.0059 in.)
Camshaft Journal Holder Inside Diameter		22.012-22.025 mm (0.8666-0.8671 in.)
Camshaft Journal Outside Diameter		21.972-21.993 mm (0.8650-0.8658 in.)
Camshaft Runout	(max)	0.10 mm (0.004 in.)
Cylinder Head Distortion	(max)	0.05 mm (0.002 in.)
Cylinder Head Cover Distortion	(max)	0.05 mm (0.002 in.)

CYLINDER, PISTON, AND RINGS

Piston Skirt/Cylinder Clearance (max)		0.12 mm (0.0047 in.)
Cylinder Bore (max)		90.015 mm (3.544 in.)
Piston Diameter 15 mm (0.60 in.) from Skirt End		89.965-89.950 mm (3.5419-3.5425 in.)
Bore x Stroke		90.0 x 62.6 mm (3.54 x 2.46 in.)
Compression Ratio		11.3:1
Cylinder Trueness (max)		0.05 mm (0.002 in.)
Piston Ring End Gap - Installed (both)		0.08-0.20 mm (0.003-0.008 in.)
Piston Ring to Groove Clearance (max)	(1st)	0.180 mm (0.0071 in.)
	(2nd)	0.150 mm (0.0059 in.)
Piston Ring Groove Width	(1st)	0.78-0.80 mm (0.0307-0.0315 in.)
	(2nd)	1.30-1.32 mm (0.0319-0.0327 in.)
	(oil)	2.01-2.03 mm (0.079-0.080 in.)
Piston Ring Thickness	(1st)	1.08-1.10 mm (0.0425-0.0433 in.)
	(2nd)	0.77-0.79 mm (0.0303-0.0311 in.)
Piston-Pin Bore		20.002-20.008 mm (0.7875-0.7877 in.)
Piston-Pin Outside Diameter		19.995-20.000 mm (0.7872-0.7874 in.)

CRANKSHAFT

Connecting Rod (small end inside diameter)	(max)	20.040 mm (0.7890 in.)
Connecting Rod (big end side-to-side)		0.30-0.65 mm (0.012-0.026 in.)
Connecting Rod (big end width)		21.95-22.00 mm (0.864-0.866 in.)
Connecting Rod (small end deflection)	(max)	3 mm (0.12 in.)
Crankshaft (web-to-web)		61.9-62.1 mm (2.437-2.448 in.)
Crankshaft Runout (max)		0.08 mm (0.003 in.)
Oil Pressure at 60°C (140°F) @ 3000 RPM	(above)	0.2 kg/cm ² (2.8 psi)
	(below)	0.6 kg/cm ² (8.5 psi)

CLUTCH	
Clutch Cable Free Play	10-15 mm (0.394-0.591 in.)
Drive Plate (fiber) Thickness (min)	2.62 mm (0.103 in.)
Drive Plate (fiber) Tab (min)	13.2 mm (0.520 in.)
Driven Plate (warpage) (max)	0.1 mm (0.004 in.)
Clutch Spring Length (min)	49.9 mm (1.96 in.)
Primary Reduction Ratio	2.960 (74/25)
Final Reduction Ratio	2.857 (40/14)
Gear Ratios	(1st) 2.538 (33/13) (2nd) 1.666 (30/18) (3rd) 1.238 (26/21) (4th) 1.000 (23/23) (5th) 0.846 (22/26) (reverse) 2.153 (28/13)
Engine Fork To Groove (side clearance)	0.10-0.30 mm (0.004-0.012 in.)
Reverse Fork to Groove (side clearance)	0.10-0.50 mm (0.004-0.020 in.)
Shift Fork Groove Width (#1, #2, & #3)	5.0-5.1 mm (0.197-0.201 in.)
Shift Fork Thickness (#1, #2, & #3)	4.8-4.9 mm (0.189-0.193 in.)
Drive Chain	Links 96 20-Pitch Length 31.94 cm (12.57 in.)
Drive Chain Slack	30-40 mm (1.2-1.6 in.)

Table of Contents (DVX 400)

Removing Engine/Transmission	3-3
Left-Side Components	3-6
Removing Left-Side Components	3-6
Right-Side Components	3-7
Removing Right-Side Components.....	3-7
Top-Side Components.....	3-10
Removing Top-Side Components	3-10
Center Crankcase Components.....	3-13
Separating Crankcase Halves.....	3-13
Disassembling Crankcase Half	3-13
Servicing Components.....	3-14
Assembling Crankcase Half	3-31
Joining Crankcase Halves.....	3-32
Installing Right-Side Components.....	3-33
Installing Left-Side Components	3-37
Installing Top-Side Components	3-37
Installing Engine/Transmission.....	3-41

Removing Engine/ Transmission

Many service procedures can be performed without removing the engine/transmission from the frame. Closely observe the note introducing each sub-section for this important information.

AT THIS POINT

If the technician's objective is to service/replace the starter clutch, starter torque limiter, starter, or water pump, the engine/transmission does not have to be removed from the frame.

Secure the ATV on a support stand to elevate the wheels.

WARNING

Make sure the ATV is solidly supported on the support stand to avoid injury.

1. Remove the seat.
2. Remove the negative cable from the battery; then remove the positive cable. Remove the battery hold-down; then remove the battery.

CAUTION

Battery acid is harmful if it contacts eyes, skin, or clothing. Care must be taken whenever handling a battery.

3. Remove the radiator cap; then drain the engine coolant.
4. Remove the lower engine protective cover (1); then drain the oil from the crankcase.

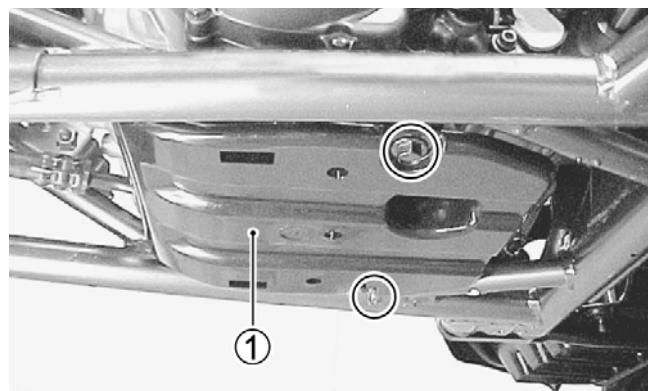

5. Drain the oil from the oil tank.
6. Remove the gearshift lever (2) and account for the two spacers.

7. Remove the engine oil outlet pipe (3) and the inlet pipe (4); then remove the spacer and O-ring from behind the outlet pipe.

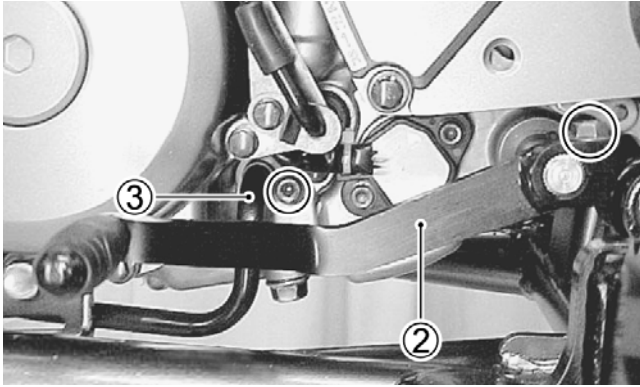

SP138

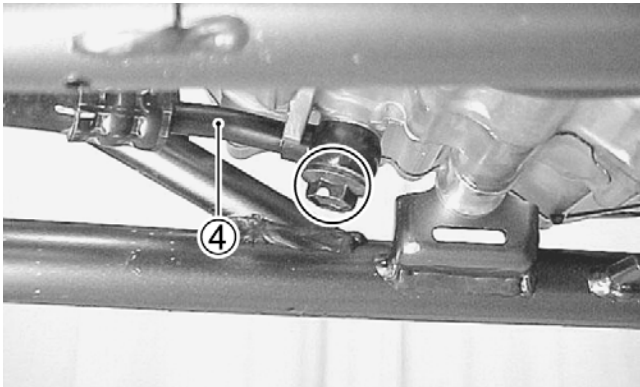

SP139

8. Remove the gas tank (see Section 4).
 9. Remove the spark plug cap (1), oil tank overflow hose (2), and the breather hose (3).

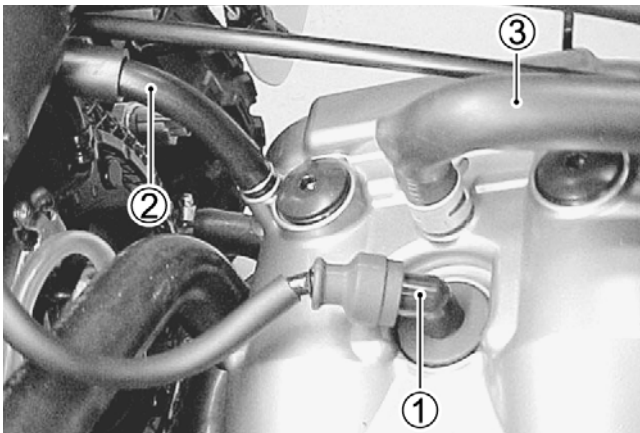

SP140

10. Remove the engine coolant inlet hose (4); then disconnect the coolant outlet hose (5).

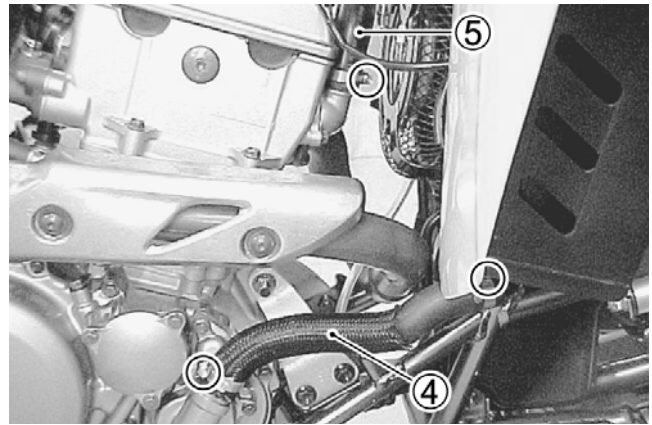

SP141

11. Disconnect the breather hose (6); then remove the oil return tank (7) and the drain-back hose (8).

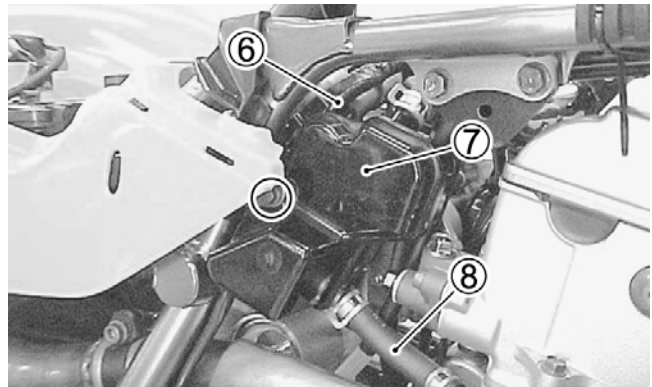

SP142

12. Remove the carburetor leaving the throttle cable and the choke cable attached; then secure the carburetor out of the way sufficiently to enable engine removal.

13. Disconnect the two starter leads from the starter and secure them out of the way.

14. Remove the engine sprocket cover; then remove the engine sprocket with the drive chain.

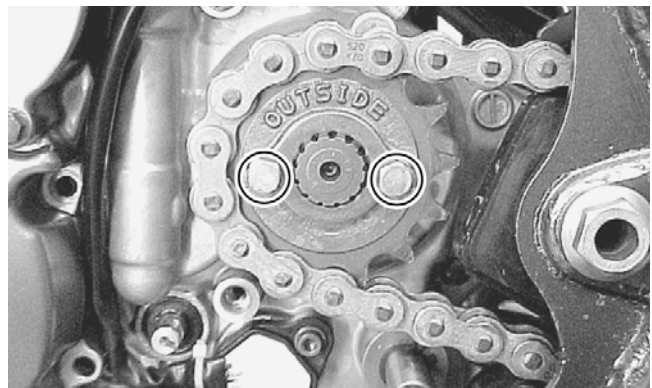

SP143

15. Remove the clutch cable bracket (1); then disconnect the clutch cable (2) from the actuator lever.

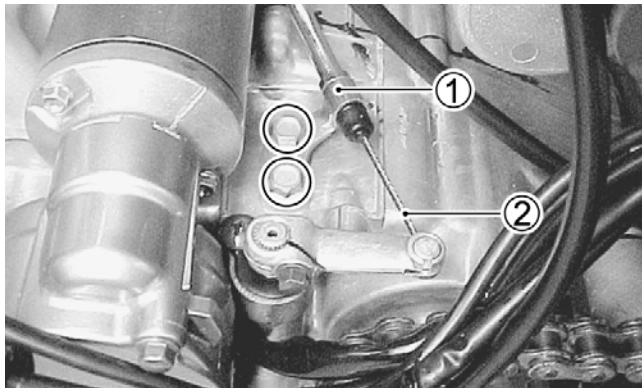

16. Disconnect the alternator lead wire couplers (3) and the neutral switch lead coupler (4).

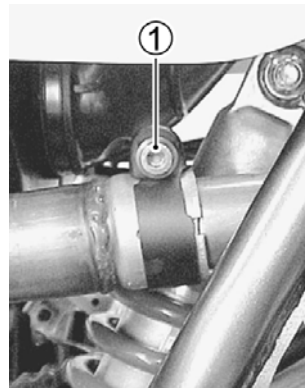

19. Remove the lower radiator bolt (3) and swing the bottom of the radiator forward.

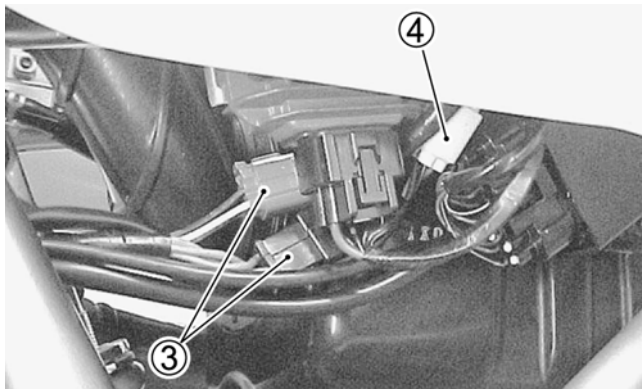
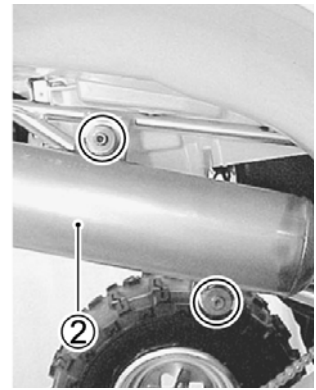

17. Remove the reverse gear selector cable bracket (5); then disconnect the reverse gear selector cable (6).

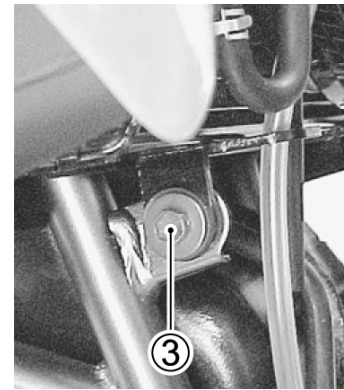

20. Remove the thermostat cover (4) and thermostat; then remove the exhaust pipe (5).

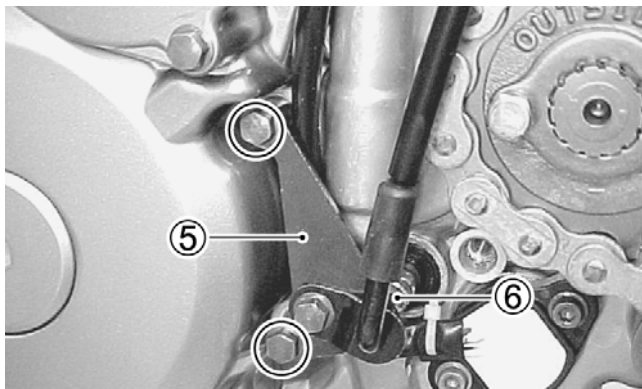

18. Loosen the muffler clamp bolt (1); then remove the muffler mounting cap screws and the muffler (2).

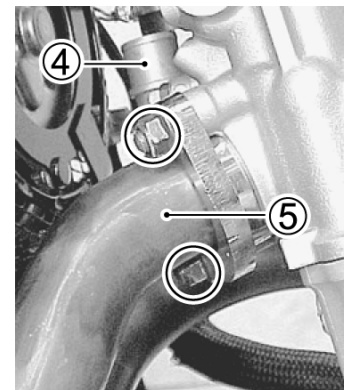

21. Support the engine with a suitable floor jack; then remove the engine mounting brackets in the following order:

- A. Upper front: Four cap screws (C), one nut (B), bolt, and two mounting brackets.
- B. Lower front (not shown): One nut and through bolt directly under the alternator housing.
- C. Upper rear: Four cap screws (C), through-bolt (A) with nut, and one mounting bracket.
- D. Lower rear: One nut (B) and through-bolt leaving two collars (D) in the frame.

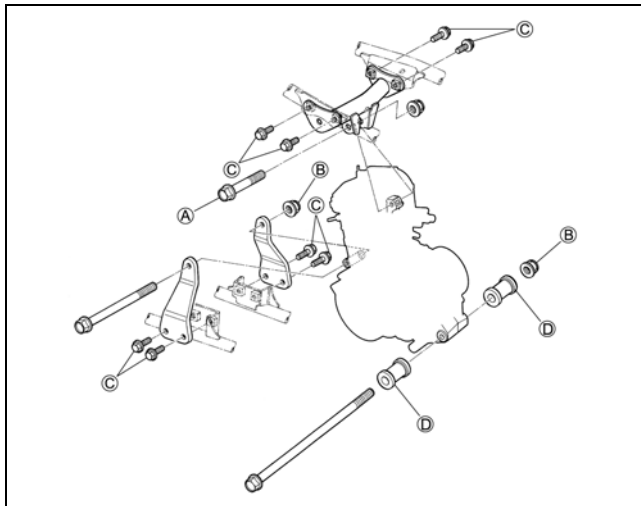

ATV2158

22. Work the engine forward to clear the swing-arm; then remove the engine assembly from the left-side of the frame.

Left-Side Components

■NOTE: For efficiency, it is preferable to remove and disassemble only those components which need to be addressed and to service only those components. The technician should use discretion and sound judgment.

👉 AT THIS POINT

To service any one specific component, only limited disassembly of components may be necessary. Note the AT THIS POINT information in each sub-section.

■NOTE: The engine/transmission does not have to be removed from the frame for this procedure.

Removing Left-Side Components

- A. Cover**
- B. Drive Gear**
- C. Rotor/Flywheel**
- D. Neutral Switch**

1. Remove the cap screws securing the starter drive cover; then remove the cover and drive gear. Account for two thrust washers and the large O-ring.

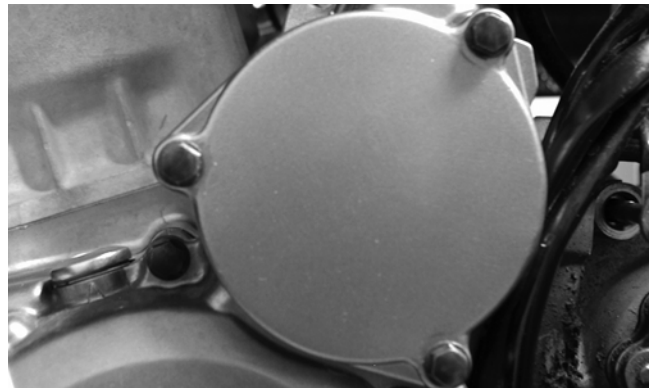

SP058

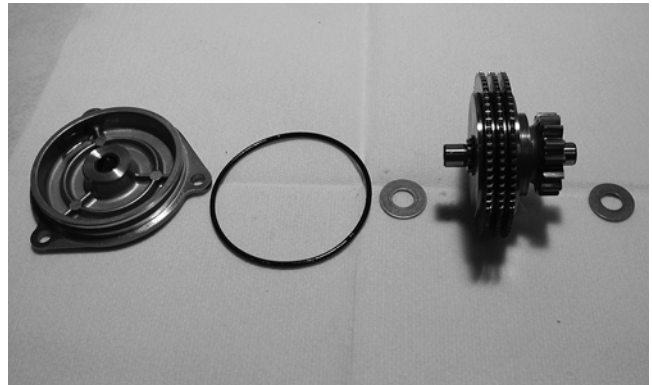

SP060

2. Remove the cap screws securing the rotor/flywheel cover; then remove the cover.

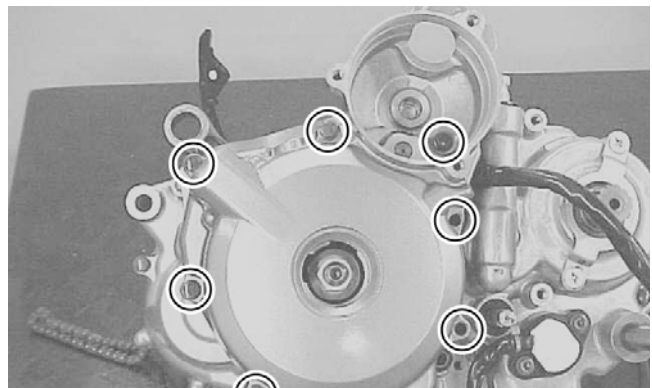

SP151

3. Remove the starter driven gear (2), two alignment pins (3), and the cover gasket (4). Account for two thrust washers from the driven gear.

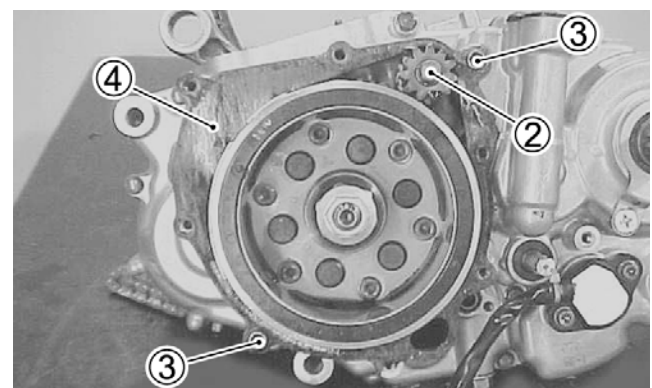

SP152

■NOTE: If the right-side components are to be removed, do not remove the rotor/flywheel. Proceed to step 7.

- Using a 27 mm offset box-end wrench, hold the rotor/flywheel; then remove the nut securing the rotor/flywheel to the crankshaft.

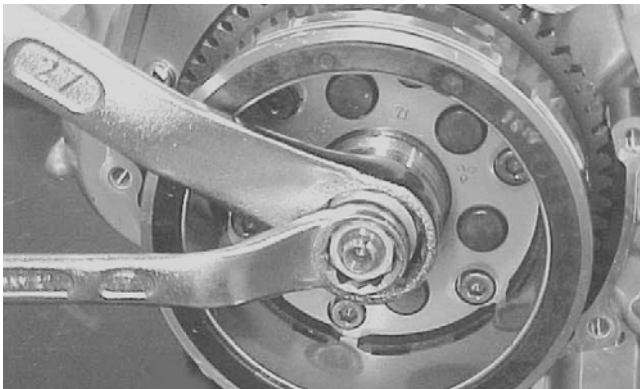

SP153

- Using an appropriate magneto rotor remover, remove the rotor/flywheel assembly from the crankshaft.
- Remove the key (3); then remove the starter driven gear (4).

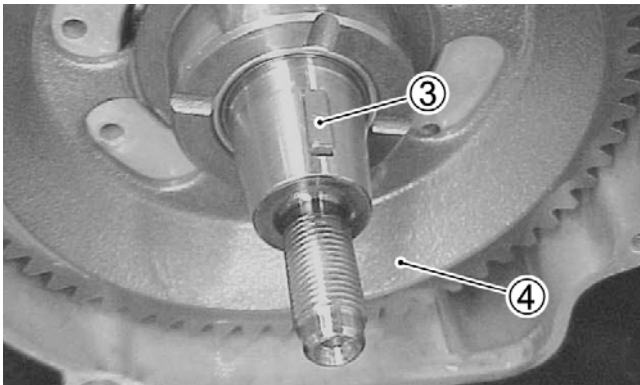

SP154

- Remove the Allen-head cap screws securing the neutral switch housing (1); then remove the switch. Account for one O-ring (2), two switch contacts (3 and 4), and the two springs behind the switch contacts.

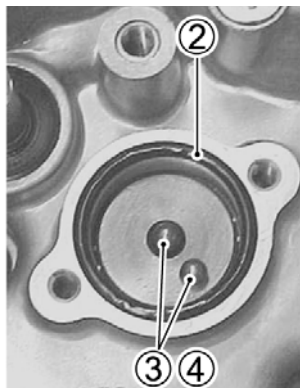
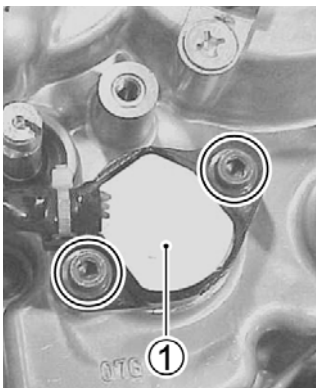

SP175A

■NOTE: To aid in installing, it is recommended that the assemblies be kept together and IN ORDER.

Right-Side Components

■NOTE: For efficiency, it is preferable to remove and disassemble only those components which need to be addressed and to service only those components. The technician should use discretion and sound judgment.

AT THIS POINT

To service any one specific component, only limited disassembly of components may be necessary. Note the AT THIS POINT information in each sub-section.

■NOTE: The engine/transmission does not have to be removed from the frame for this procedure.

3

Removing Right-Side Components

- A. Clutch Cover
- B. Clutch Sleeve Hub Assembly
- C. Primary Driven Gear Assembly
- D. Oil Pump Idler Gear and Driven Gear
- E. Oil Pump
- F. Shift Shaft
- G. Shift Cam Driven Gear
- H. Balancer Driven Gear and Drive Gear
- I. Neutral Switch

- Remove the cap screws securing the clutch cover to the crankcase noting the position of the cap screw with a sealing washer (A).

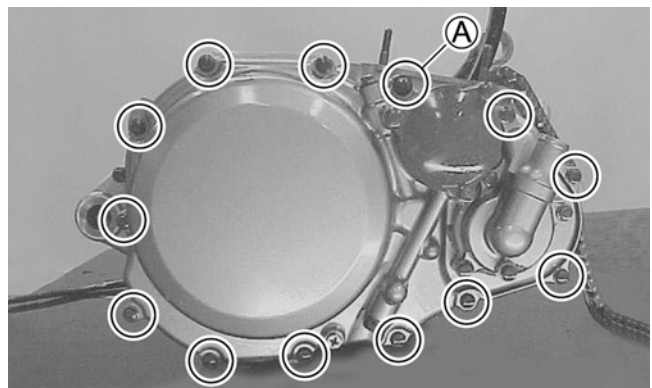

SP155

2. Remove the alignment pins (5) and the gasket (6).

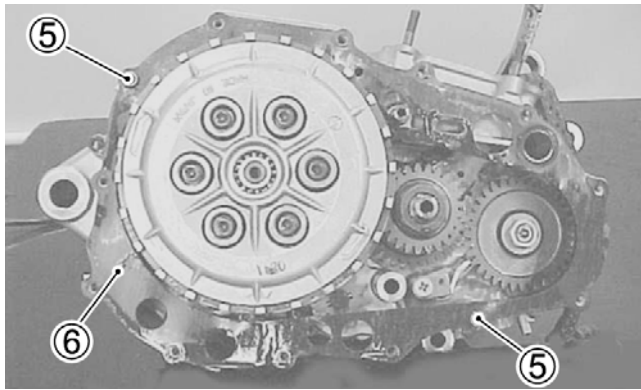

SP156

3. Hold the rotor/flywheel nut using a 27 mm offset wrench; then working diagonally, remove the clutch bolt and springs.

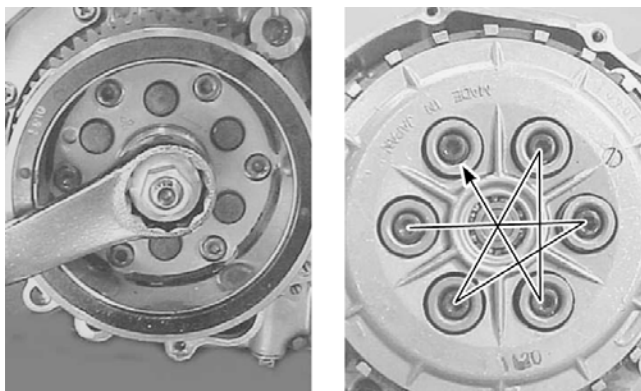

SP157A

4. Remove the clutch pressure disc; then remove the clutch drive and driven plates.

5. Remove the clutch release pin (1) and the push rod (2); then flatten the clutch sleeve hub washer (3).

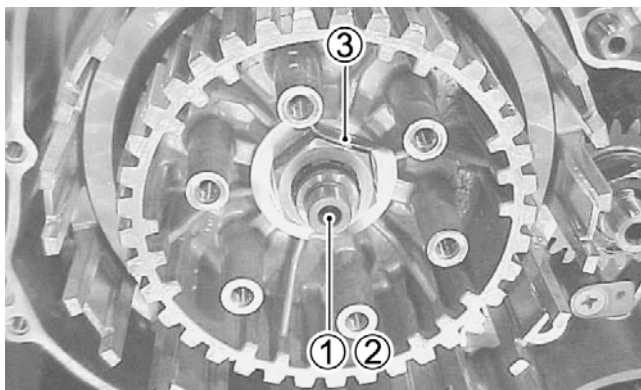

SP159

6. Using an appropriate clutch sleeve hub holder, secure the clutch sleeve hub and remove the hub nut; then remove the clutch sleeve hub.

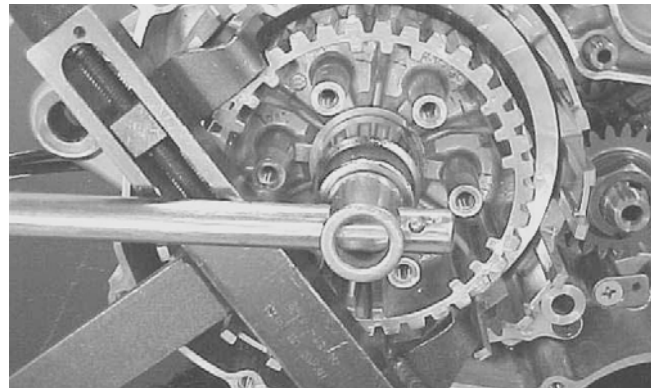

SP160

7. Remove the primary driven gear assembly (1) and the washer (2); then remove the collar (3).

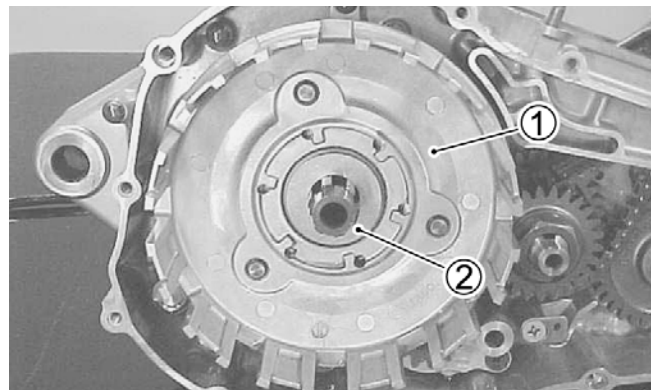

SP161

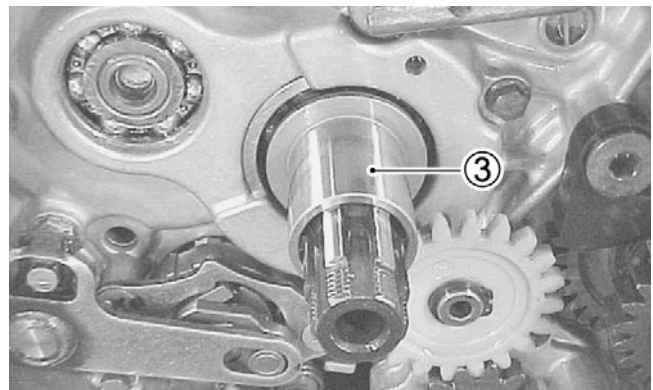

SP162

8. Remove the cam chain tensioner (4) and the cam chain (5); then remove the oil pipe (6).

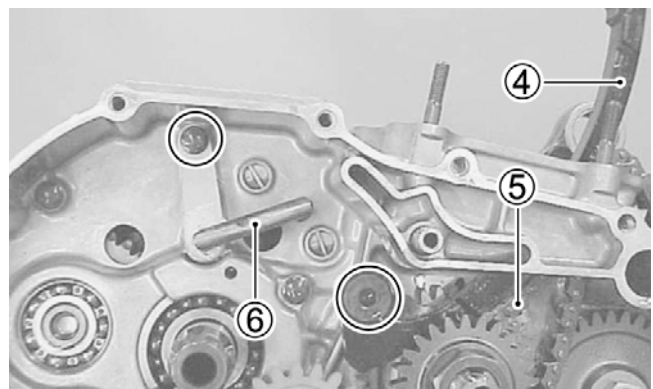

SP163

■NOTE: If the top-side components have not been removed, the tensioner and cam chain cannot be removed.

9. Remove the oil pump idler gear (7), the oil pump driven gear (8), and the oil pump drive pin (9); then remove the screws securing the oil pump.

■NOTE: Do not remove the circlip (A) before separating the crankcase halves to prevent the idler shaft from falling into the crankcase.

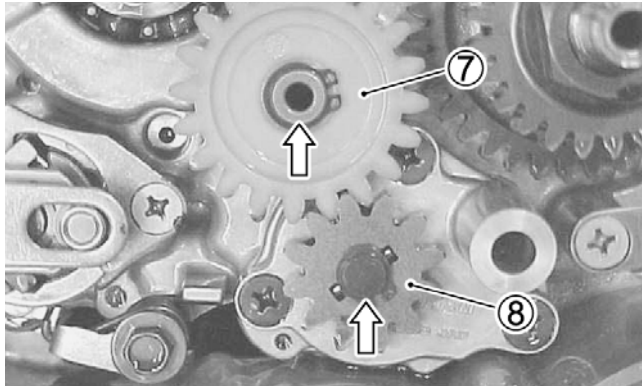

SP164

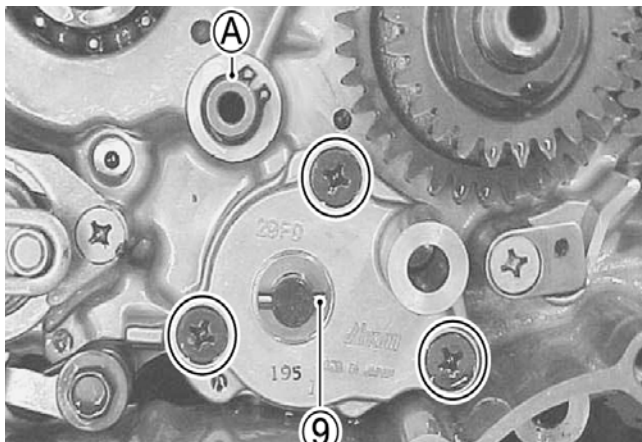

SP165

10. Remove the circlip (2) from the left side of the shift shaft; then remove the shift shaft (1).

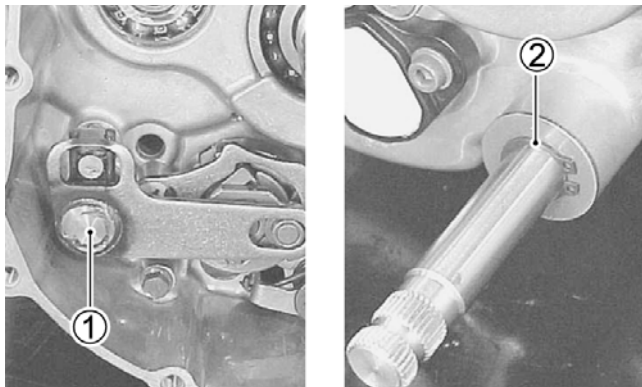

SP166A

11. Remove the two screws securing the shift pawl lifter (3) and the shift cam driven gear (4). Remove the shift cam stopper arm (5).

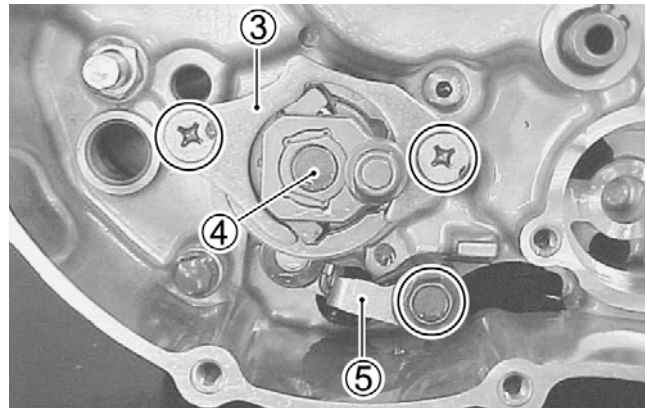

SP168

12. Remove the shift cam driven gear bolt.

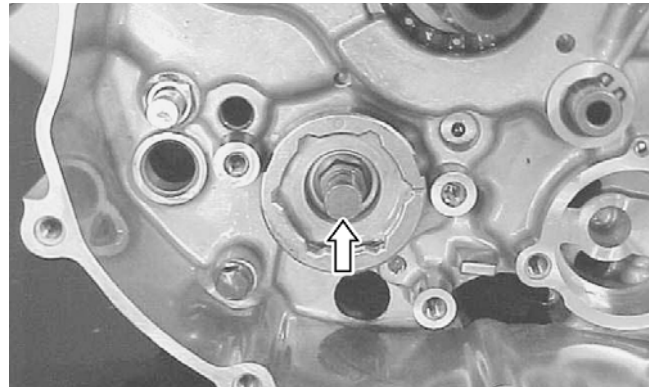

SP169

13. Holding the rotor/flywheel and using a 27 mm off-set wrench, remove the crank balancer driven gear nut; then remove the washer, driven gear, and locator pin.

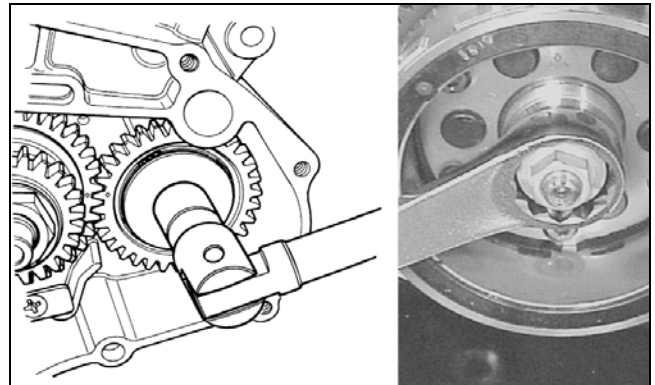

ATV2159A

14. Remove the primary drive gear nut, washer, and primary drive gear; then remove the key (1), balancer drive gear (2), and pin.

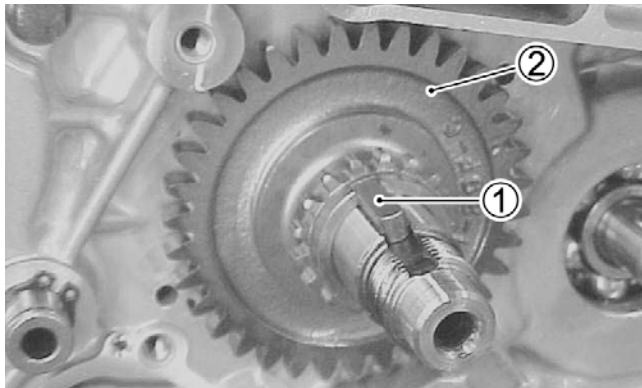

SP171

15. Holding the rotor/flywheel with a 27 mm offset wrench, remove the rotor nut; then remove the rotor/flywheel using the magneto rotor remover.

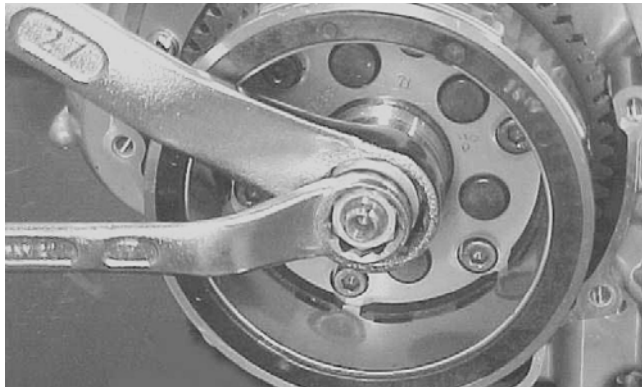

SP172

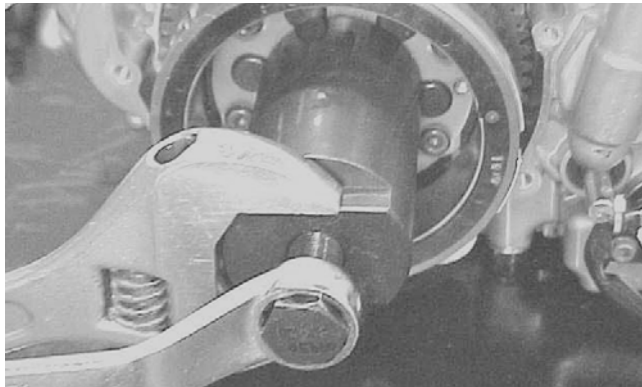

SP173

16. Remove the key (3); then remove the starter drive gear (4).

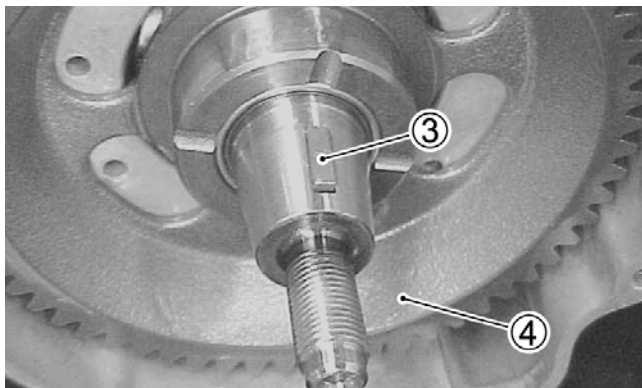

SP174

17. Remove the Allen-head cap screws securing the neutral switch housing (1); then remove the switch. Account for one O-ring (2) two switch contacts (3 and 4), and two springs behind the switch contacts.

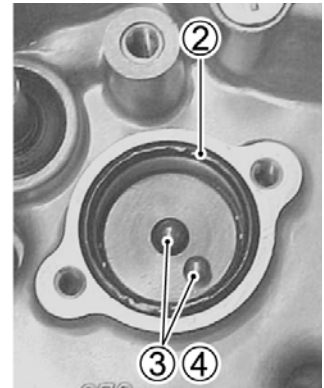
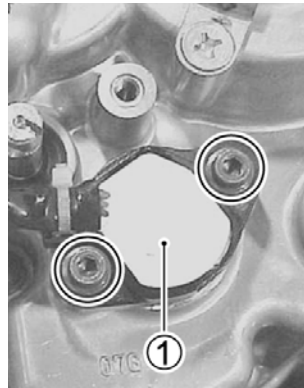

SP175A

■NOTE: To aid in installing, it is recommended that the assemblies be kept together and IN ORDER.

Top-Side Components

■NOTE: For efficiency, it is preferable to remove and disassemble only those components which need to be addressed and to service only those components. The technician should use discretion and sound judgment.

AT THIS POINT

To service any one specific component, only limited disassembly of components may be necessary. Note the AT THIS POINT information in each sub-section.

■NOTE: The engine/transmission does not have to be removed from the frame for this procedure.

Removing Top-Side Components

- A. Valve Cover
- B. Cylinder Head
- C. Cylinder

■NOTE: Remove the spark plug, timing inspection plug (1), and the alternator cover cap (2); then using a socket wrench, rotate the camshaft to top-dead-center of the compression stroke.

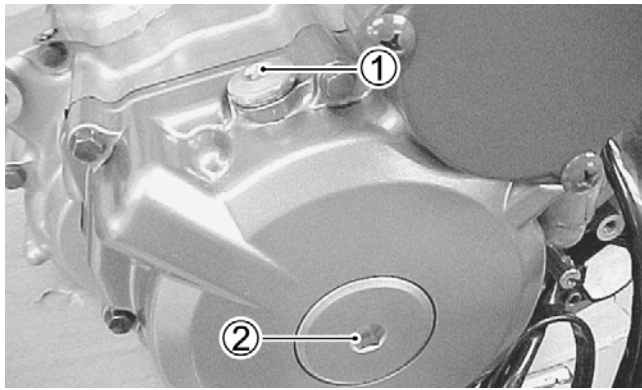

SP177

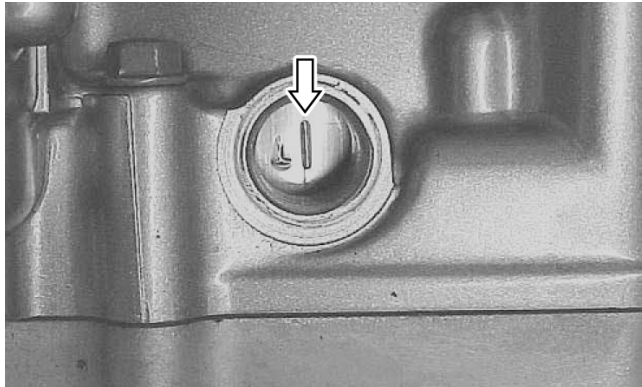

SP178

1. Remove the cap screw on the end of the tensioner; then remove the two Allen-head cap screws securing the tensioner adjuster assembly and remove the assembly. Account for a gasket and spring.



SP179



SP180

2. Remove the valve cover cap screws in a diagonal pattern; then remove the valve cover accounting for two washers (1) and one rubber cushion (2).

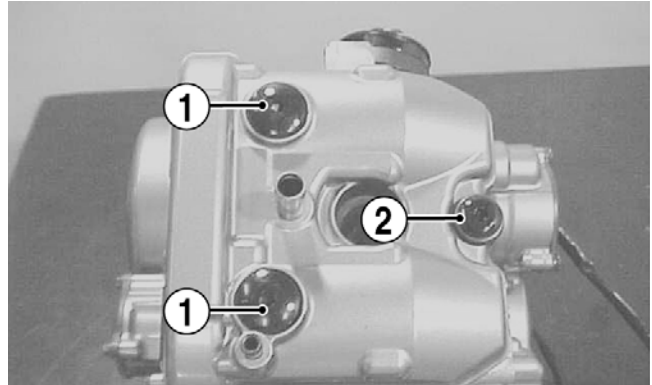

SP181A

■NOTE: Before removing the camshaft journal caps, the piston must be at top-dead-center of the compression stroke.

3. Remove the cam chain guide (3); then remove the camshaft journal cap screws and journal caps (4).

3

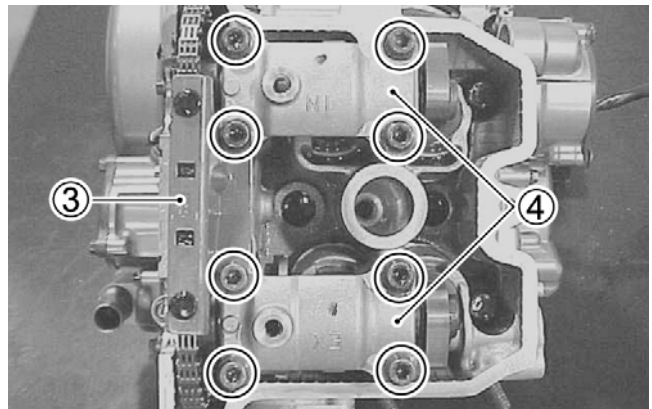

SP182

■NOTE: Use caution not to drop the alignment pins or the camshaft drive chain into the crankcase.

4. Remove the four alignment pins (5); then remove the intake camshaft (6) keeping tension on the chain.
5. Remove the exhaust camshaft (7); then secure the chain to prevent it from dropping into the crankcase.

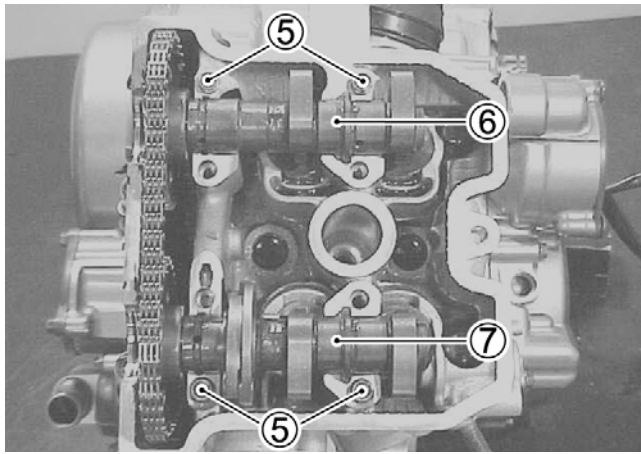

SP183

6. Remove the four cylinder head cap screws in a diagonal pattern noting the locations of the 6 mm and 10 mm cap screws for installing purposes; then remove the cylinder head. Account for two alignment pins and the head gasket.

■NOTE: If the cylinder head sticks, a light tap with a plastic mallet may be needed to loosen it.

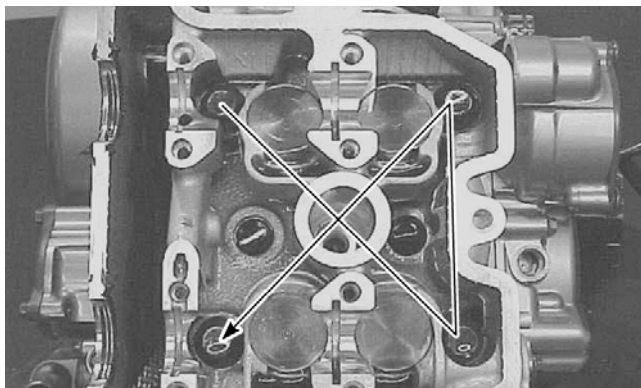

SP184

7. Remove the cam chain guide (3); then remove the remaining two nuts (4) securing the cylinder to the crankcase.

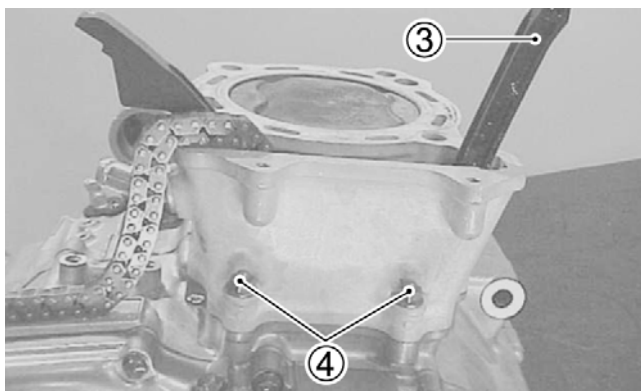

SP185

8. Lift the cylinder off the crankcase taking care not to allow the piston to drop against the crankcase. Account for the gasket and two alignment pins.

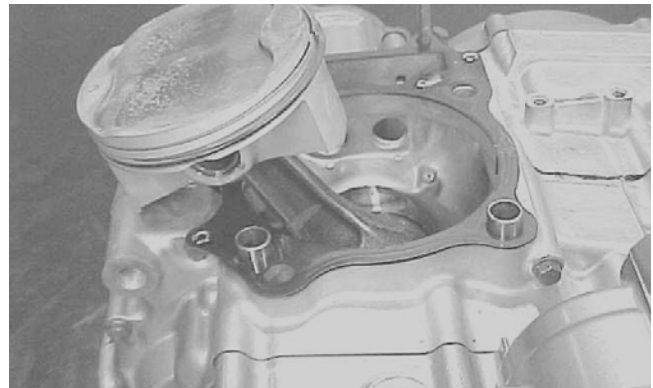

SP186

👉 **AT THIS POINT**

To service cylinder, see Servicing Top-Side Components sub-section.

⚠ **CAUTION**

When removing the cylinder, be sure to support the piston to prevent damage to the crankcase and piston.

■NOTE: Place a clean rag over the cylinder to prevent the piston-pin circlip from dropping into the crankcase.

9. Using an awl, remove one piston-pin circlip.
10. Push out the piston pin; then remove the piston. Account for the second piston-pin circlip.

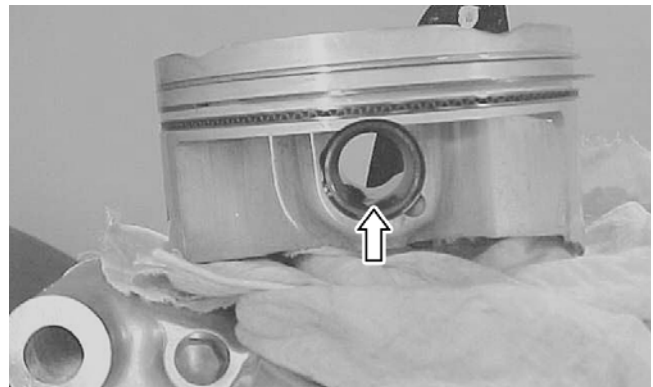

SP187

👉 **AT THIS POINT**

To service center crankcase components only, proceed to Separating Crankcase Halves.

Center Crankcase Components

■NOTE: This procedure cannot be done with the engine/transmission in the frame. Complete Removing procedures for Left-Side, Right-Side, and Top-Side must precede this procedure.

■NOTE: For efficiency, it is preferable to remove and disassemble only those components which need to be addressed and to service only those components. The technician should use discretion and sound judgment.

Separating Crankcase Halves

1. Remove the cap screws from the left-side crankcase; then remove the right-side cap screws.

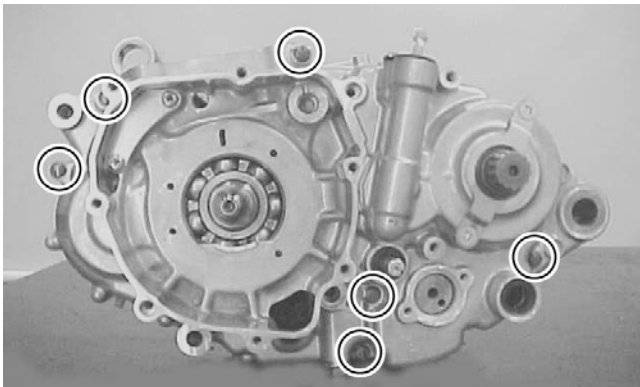

SP188

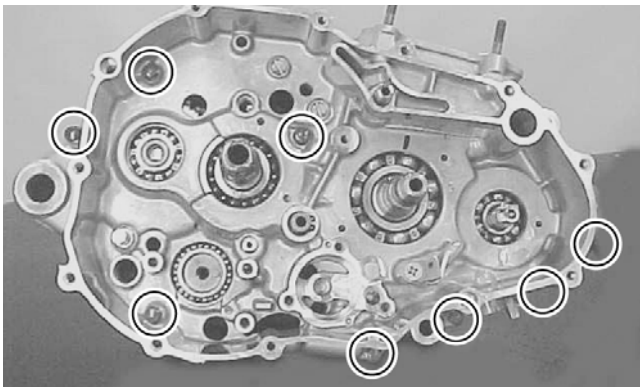

SP189

2. Install Crankcase Separator/Crankshaft Remover (p/n 0444-009) on the right-side crankcase aligning the puller screw with the crankshaft; then separate the crankcase.

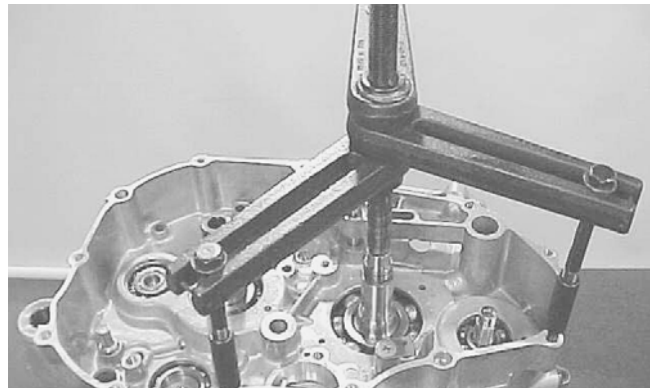

SP190

Disassembling Crankcase Half

1. Remove the alignment pin (5), shift fork shaft (6), reverse lock shaft (7), shift forks (8), and the shift cam (9).

3

■NOTE: Note the location of each shift fork for assembling purposes.

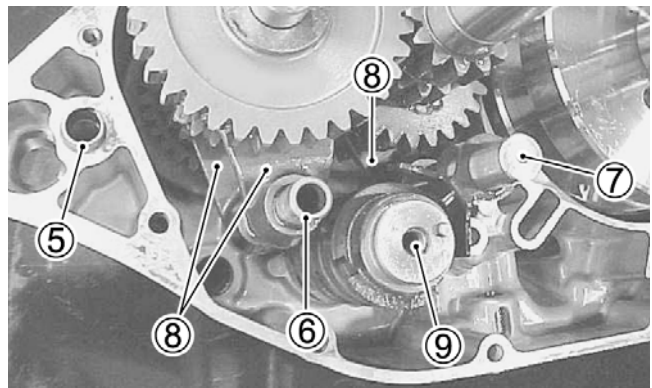

SP191

2. Remove the reverse idler gear and shaft; then remove the countershaft assembly (1) and drive-shaft assembly (2).

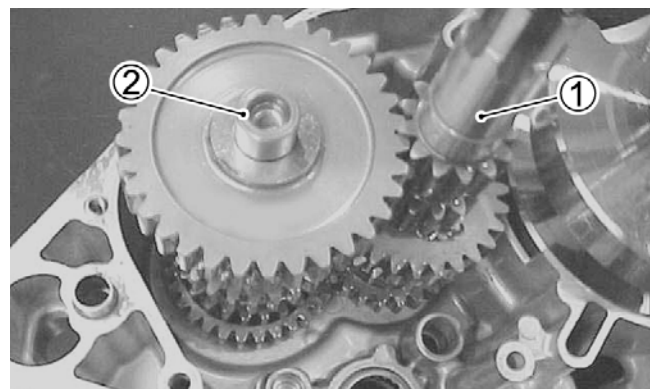

SP193

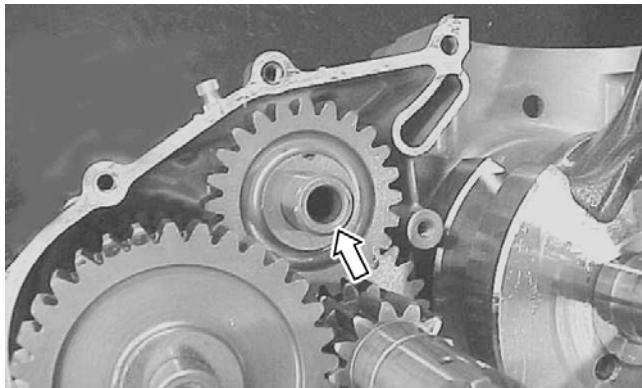

SP192

3. Remove the crank balancer shaft; then using the Crankcase Separator/Crankshaft Remover (p/n 0444-009), remove the crankshaft from the crankcase.

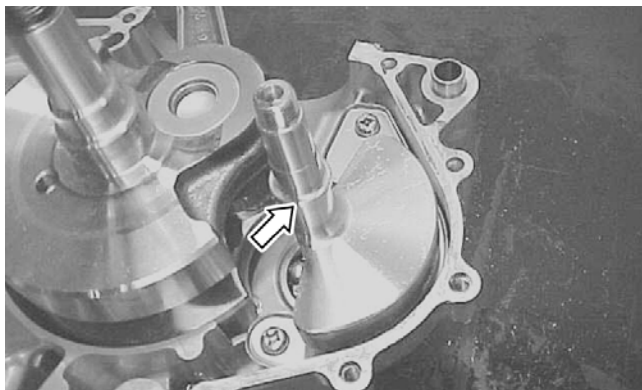

SP194

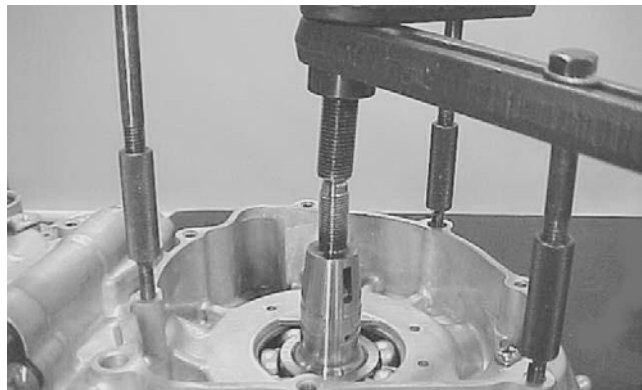

SP195

Table of Contents (Servicing Components)

■NOTE: Critical engine/transmission specifications are located at the beginning of this section.

Servicing Top-Side Components	3-14
Valve Assembly	3-14
Piston Assembly	3-19
Cylinder/Cylinder Head Assembly	3-20
Servicing Left-Side Components	3-23
Starter Clutch	3-23
Starter Torque Limiter	3-23
Servicing Right-Side Components	3-24
Primary Clutch Assembly	3-24
Oil Pump	3-24
Crank Balancer Driven Gear	3-25
Servicing Center Crankcase Components	3-25
Crankcase	3-25
Crankshaft Assembly	3-27
Driveshaft	3-28
Countershaft	3-30

Servicing Top-Side Components

■NOTE: Whenever a part is worn excessively, cracked, or damaged in any way, replacement is necessary.

VALVE ASSEMBLY

When servicing valve assembly, inspect valve seats, valve stems, valve faces, and valve stem ends for pits, burn marks, or other signs of abnormal wear.

■NOTE: Whenever a valve is out of tolerance, it must be replaced.

Cleaning/Inspecting Valve Cover

■NOTE: Always note the position of each removed part. Organize the parts in relative groups (i.e. exhaust or intake) so they can be installed in their original positions.

1. Remove the intake hose; then remove the thermostat housing (1) and thermostat (2).

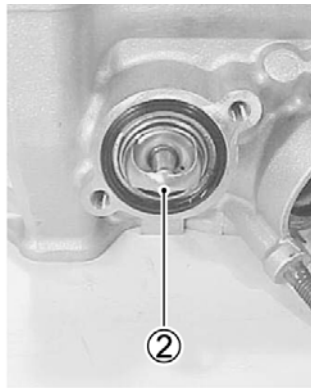
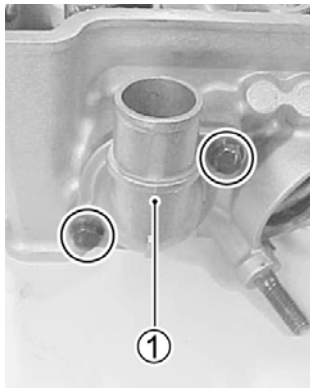

SP196A

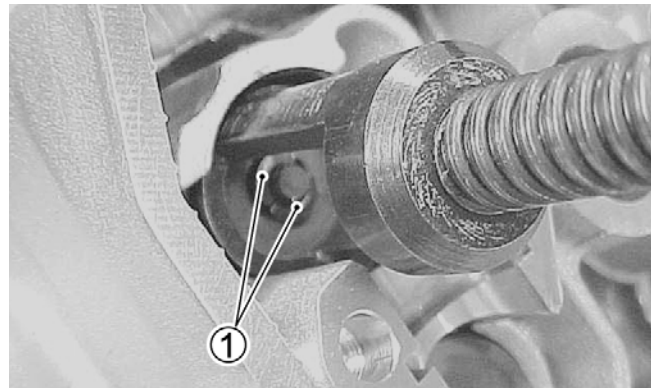

SP200

2. Using a suitable magnet, remove the tappets (3) and the shims (4).

4. Remove the valve spring retainer (2) and the valve spring (3); then remove the valve (4).

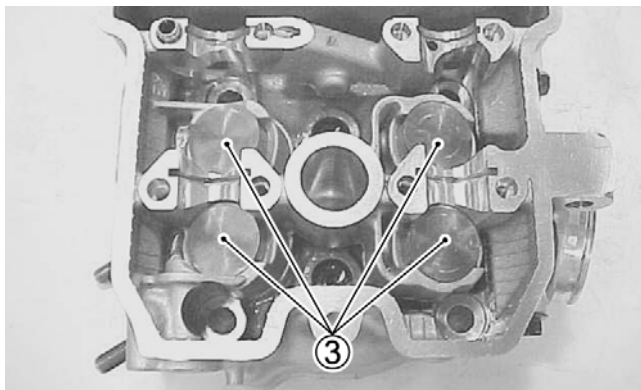

SP199

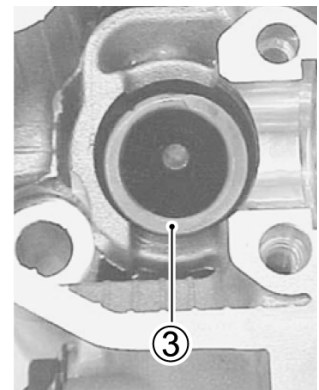
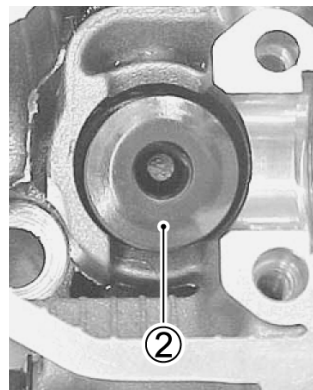

SP201A

3

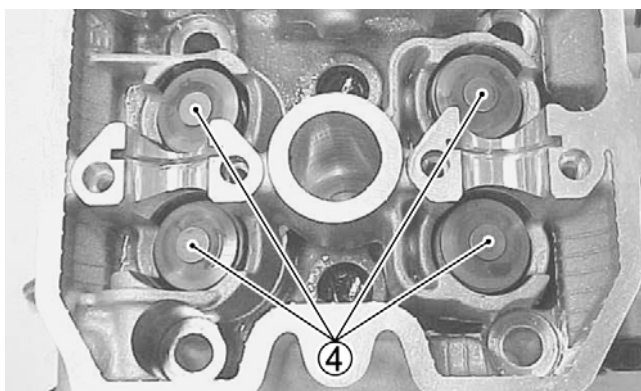

SP198

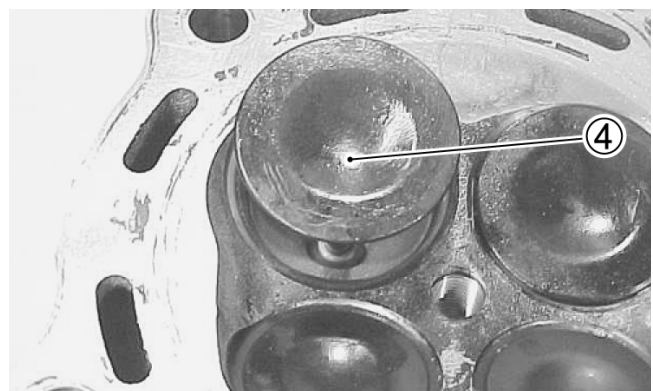

SP203

3. Using a valve spring compressor and special adapter to compress the valve springs, remove the valve cotters (1) from the valve stems.

5. Remove the oil seal with a needle-nose pliers; then remove the valve spring seat.

■NOTE: Keep valve, tappets, springs, and cotters together and note the location from which they came on the cylinder head.

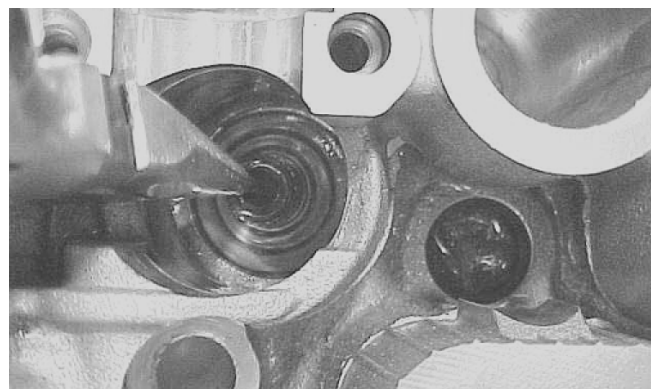

SP204

6. Check the gasket surface of the cylinder head for distortion using a straightedge and feeler gauge. Take clearance readings at several places. If any clearance reading exceeds the service limit specifications, replace the cylinder head with a new one.

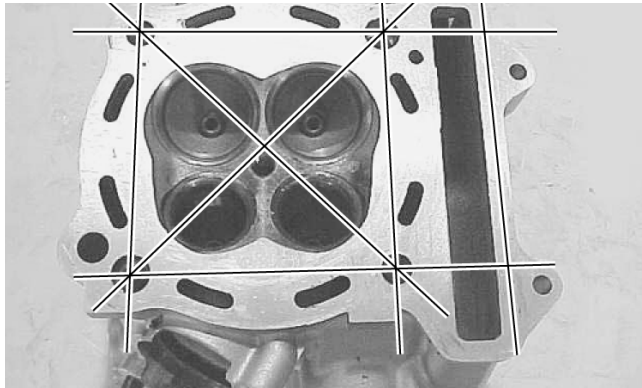

SP205

Measuring Valve Stem Runout

1. Support each valve stem end with the V Blocks (p/n 0644-022); then check the valve stem runout using a dial indicator.

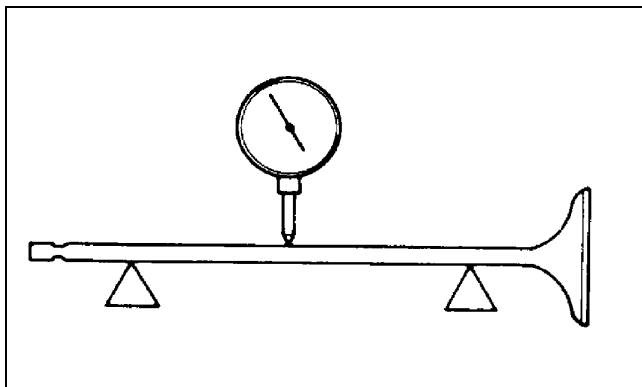

ATV-1082

2. Maximum runout must not exceed specifications.

Measuring Valve Stem Outside Diameter

1. Using a micrometer, measure the valve stem outside diameter.
2. Acceptable diameter range (intake valve) must be within specifications.
3. Acceptable diameter range (exhaust valve) must be within specifications.

Measuring Valve Face/Seat Width

1. Using a micrometer, measure the width of the valve face.

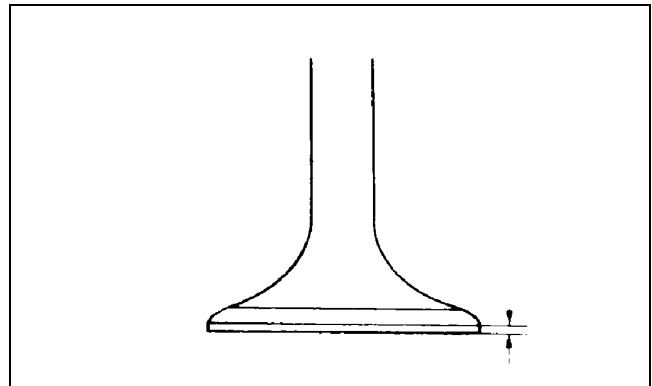

ATV-1004

2. Acceptable width range must be within specifications.

Measuring Valve Face Radial Runout

1. Mount a dial indicator on the surface plate; then place the valve stem on a set of V blocks.
2. Position the dial indicator contact point on the outside edge of the valve face; then zero the indicator.

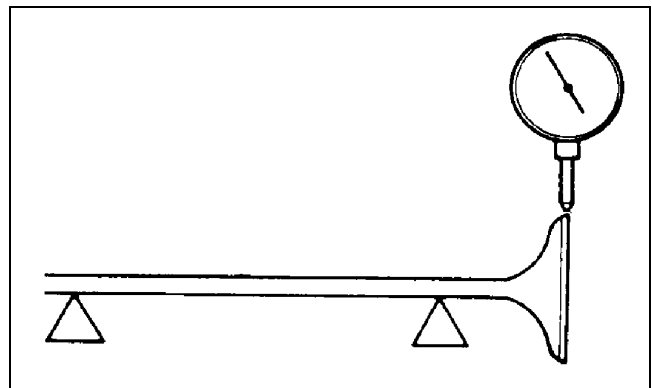

ATV1082A

3. Rotate the valve in the V blocks.
4. Maximum runout must not exceed specifications.

Measuring Valve Guide/Valve Stem Deflection (Wobble Method)

1. Mount a dial indicator and base on the surface plate; then place the cylinder head on the surface plate.
2. Install the valve into the cylinder head; then position the dial indicator contact point against the outside edge of the valve face. Zero the indicator.

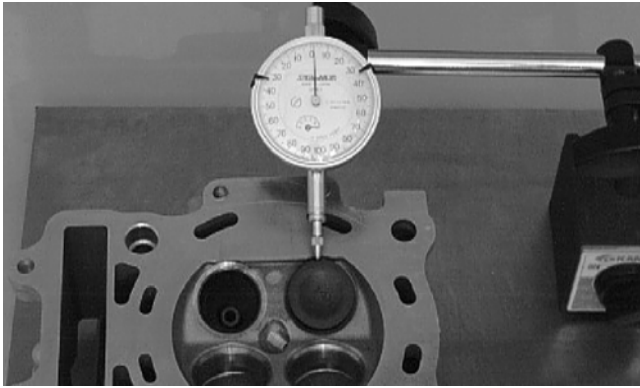

CC131D

3. Push the valve from side to side; then from top to bottom.
4. Maximum “wobble” deflection must not exceed specifications.

Measuring Valve Guide (Inside Diameter)

1. Insert a snap gauge 1/2 way down into each valve guide bore; then remove the gauge and measure it with a micrometer.
2. Acceptable inside diameter range must be within specifications.
3. If a valve guide is out of tolerance, it must be replaced.

Replacing Valve Guide

■NOTE: If a valve guide is worn or damaged, it must be replaced.

1. If a valve guide needs replacing, insert a valve guide remover into the valve seat side of the valve guide. Using a hammer, gently drive the valve guide out of the cylinder head.

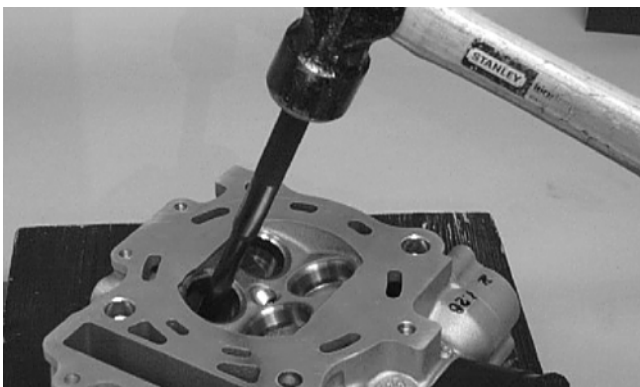

CC137D

2. Using an appropriate valve guide reamer, remove any burrs or tight areas from the valve guide journals.

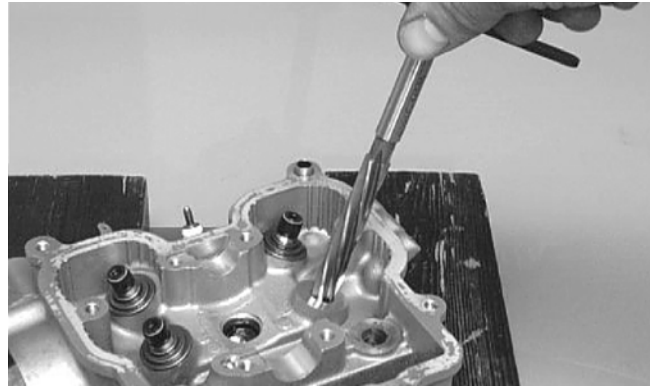

CC142D

3. To install a valve guide, use a valve guide installer and gently drive a valve guide with a retaining clip into the bore from the valve spring side until the retaining clip just contacts the cylinder head.

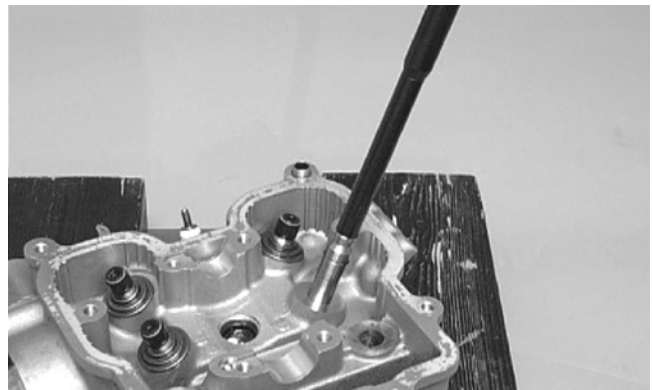

CC143D

4. After installing the guide, use the standard valve guide reamer to remove all burrs and tight areas that may remain in each valve guide.

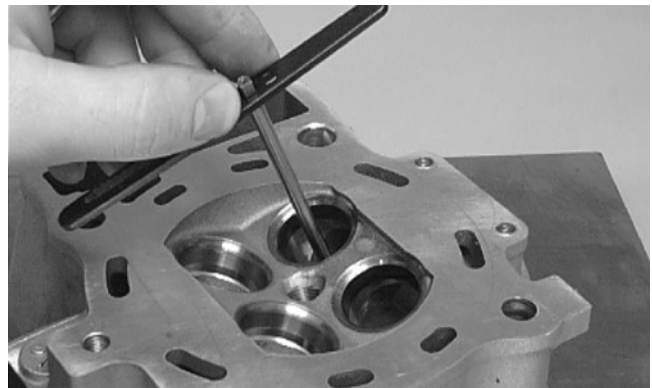

CC138D

Valve Seat/Guide Servicing Flow Chart

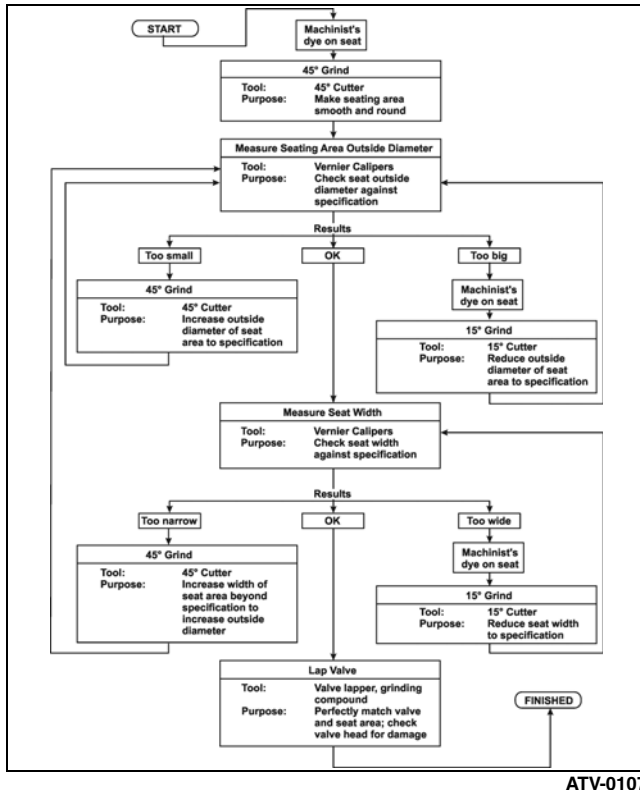

Grinding Valve Seats

NOTE: If the valve seat is beyond servicing, the cylinder head must be replaced.

1. Insert an exhaust valve seat pilot shaft into an exhaust valve guide. Slide an exhaust valve seat grinding tool onto the pilot shaft; then using light pressure on a driver handle and a deep socket, grind the exhaust valve seat until within specifications.

NOTE: Repeat procedure on the remaining exhaust valve.



CC139D

2. Insert an intake valve seat pilot shaft into one of the intake valve guides. Slide the intake valve seat grinding tool onto the pilot shaft; then using light pressure on a driver handle and a deep socket, grind the intake valve seat until within specifications.

NOTE: Repeat procedure on the remaining intake valve.



CC140D

Lapping Valves

NOTE: Do not grind the valves. If a valve is damaged, it must be replaced.

1. Remove all carbon from the valves.
2. Lubricate each valve stem with light oil; then apply a small amount of valve lapping compound to the entire seating face of each valve.
3. Attach the suction cup of a valve lapping tool to the head of the valve.
4. Rotate the valve until the valve and seat are evenly polished.
5. Clean all compound residue from the valve and seat.

Installing Valves

1. Apply grease to the inside surface of the valve seals; then place a lower spring seat and valve guide seal over each valve guide.

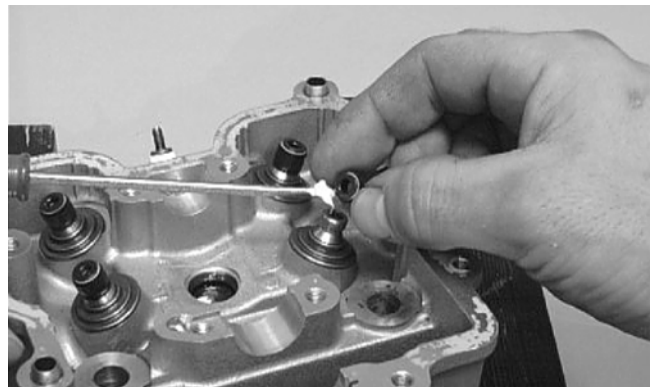

CC144D

2. Insert each valve into its original valve location.
3. Install the valve springs with the painted end of the spring facing away from the cylinder head.

■NOTE: If the painted end is not visible, install the ends of the springs with the closest coils toward the head.

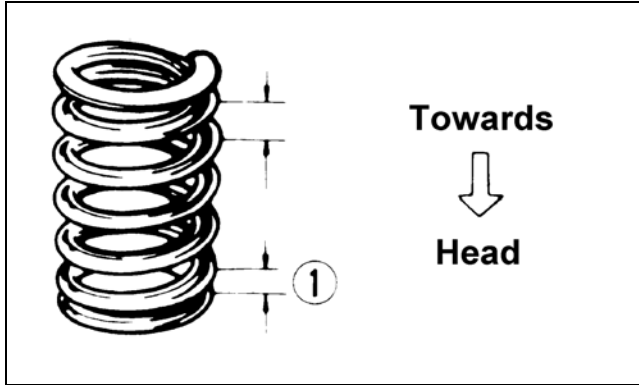

ATV-1011A

4. Place a spring retainer over the valve springs; then using the valve spring compressor, compress the valve springs and install the valve cotters.

PISTON ASSEMBLY

■NOTE: Whenever a piston, rings, or pin are out of tolerance, they must be replaced.

Cleaning/Inspecting Piston

1. Using a non-metallic carbon removal tool, remove any carbon buildup from the dome of the piston.
2. Inspect the piston for cracks in the piston pin, dome, and skirt areas.
3. Inspect the piston for seizure marks or scuffing. Repair with #400 grit wet-or-dry sandpaper and water or honing oil.



AN135

■NOTE: If scuffing or seizure marks are too deep to correct with the sandpaper, replace the piston.

4. Inspect the perimeter of each piston for signs of excessive "blowby." Excessive "blowby" indicates worn piston rings, or an out-of-round cylinder.

Removing Piston Rings

1. Starting with the top ring, slide one end of the ring out of the ring-groove.



CC400D

2. Remove each ring by working it toward the dome of the piston while rotating it out of the groove.

■NOTE: If the existing rings will not be replaced with new ones, note the location of each ring for proper installation. When installing new rings, install as a complete set only.

3

Cleaning/Inspecting Piston Rings

1. Take an old piston ring and snap it into two pieces; then grind the end of the old ring to a 45° angle and to a sharp edge.
2. Using the sharpened ring as a tool, clean carbon from the ring-grooves. Be sure to position the ring with its tapered side up.

⚠ CAUTION

Improper cleaning of the ring-grooves by the use of the wrong type of ring-groove cleaner will result in severe damage to the piston.

Measuring Piston-Ring End Gap (Installed)

1. Place each piston ring in the wear portion of the cylinder. Use the piston to position each ring squarely in the cylinder.
2. Using a feeler gauge, measure each piston-ring end gap. Acceptable ring end gap must be within specifications.

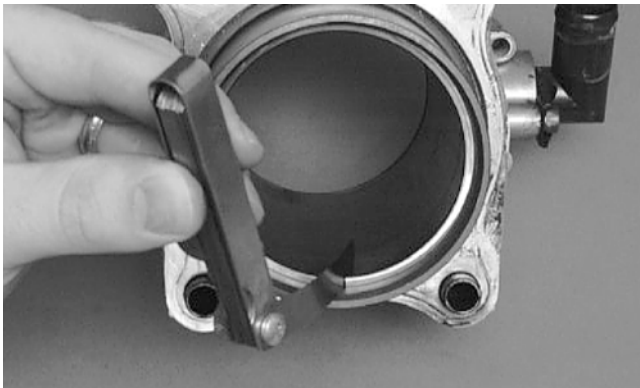

CC280D

Measuring Piston Pin (Outside Diameter) and Piston-Pin Bore

1. Measure the piston pin outside diameter at each end and in the center. If measurement is not within specifications, the piston pin must be replaced.

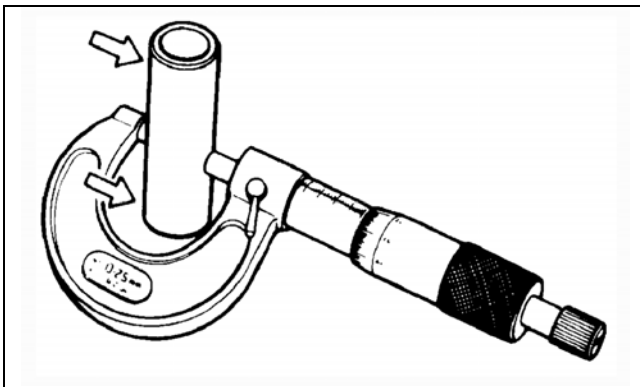

ATV-1070

2. Insert an inside dial indicator into the piston-pin bore. The diameter must not exceed specifications. Take two measurements to ensure accuracy.

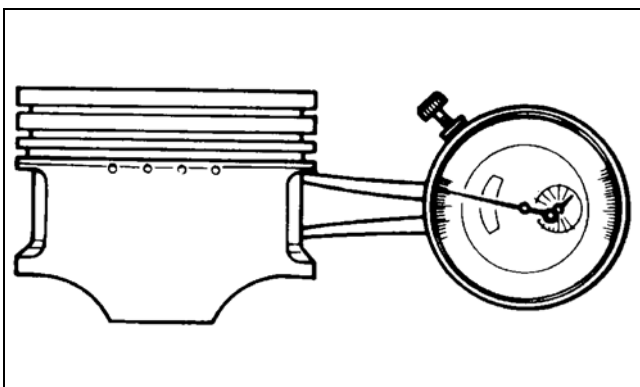

ATV-1069

Measuring Piston Skirt/ Cylinder Clearance

1. Measure the cylinder front to back in six places.

2. Measure the corresponding piston diameter at a point 15 mm (0.6 in.) above the piston skirt at a right angle to the piston-pin bore. Subtract this measurement from the measurement in step 1. The difference (clearance) must be within specifications.

CYLINDER/CYLINDER HEAD ASSEMBLY

■NOTE: If the cylinder/cylinder head assembly cannot be trued, they must be replaced.

Cleaning/Inspecting Cylinder Head

⚠ CAUTION

The cylinder head studs must be removed for this procedure.

1. Using a non-metallic carbon removal tool, remove any carbon buildup from the combustion chamber being careful not to nick, scrape, or damage the combustion chamber or the sealing surface.
2. Inspect the spark plug hole for any damaged threads. Repair damaged threads using a "heli-coil" insert.
3. Place the cylinder head on the surface plate covered with #400 grit wet-or-dry sandpaper. Using light pressure, move the cylinder head in a figure eight motion. Inspect the sealing surface for any indication of high spots. A high spot can be noted by a bright metallic finish. Correct any high spots before assembly by continuing to move the cylinder head in a figure eight motion until a uniform bright metallic finish is attained.

⚠ CAUTION

Water or parts-cleaning solvent must be used in conjunction with the wet-or-dry sandpaper or damage to the sealing surface may result.

Measuring Cylinder Head Distortion

1. Remove any carbon buildup in the combustion chamber.
2. Lay a straightedge across the cylinder head; then using a feeler gauge, check the distortion factor between the head and the straightedge.
3. Maximum distortion must not exceed specifications.

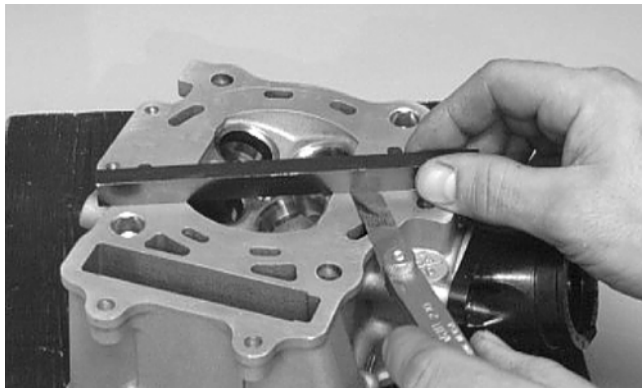

CC141D

Cleaning/Inspecting Cylinder

1. Wash the cylinder in parts-cleaning solvent.
2. Inspect the cylinder for pitting, scoring, scuffing, warpage, and corrosion.
3. Place the cylinder on the surface plate covered with #400 grit wet-or-dry sandpaper. Using light pressure, move the cylinder in a figure eight motion. Inspect the sealing surface for any indication of high spots. A high spot can be noted by a bright metallic finish. Correct any high spots before assembly by continuing to move the cylinder in a figure eight motion until a uniform bright metallic finish is attained.

⚠ CAUTION

Water or parts-cleaning solvent must be used in conjunction with the wet-or-dry sandpaper or damage to the sealing surface may result.

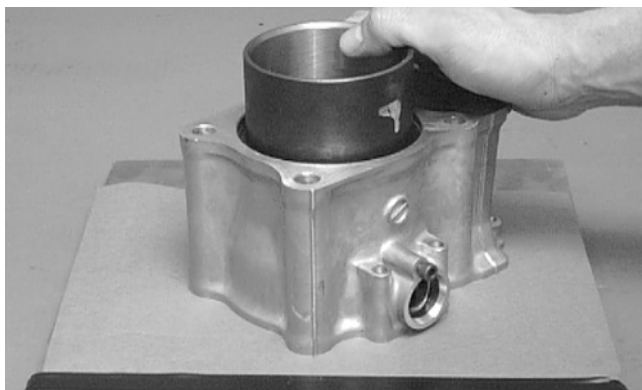

CC129D

Inspecting Cam Chain Guide

1. Inspect cam chain guide for cuts, tears, breaks, or chips.
2. If the chain guide is damaged, it must be replaced.

Inspecting Cylinder

1. Using a slide gauge and a dial indicator or a snap gauge, measure the cylinder bore diameter in three locations from top to bottom and again from top to bottom at 90° from the first measurements for a total of six measurements. The trueness (out-of-roundness) is the difference between the highest and lowest readings. Maximum trueness (out-of-roundness) must not exceed specifications.

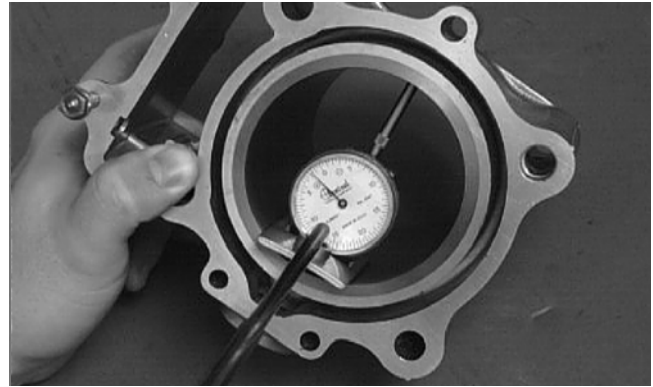

CC127D

3

2. Wash the cylinder in parts-cleaning solvent.
3. Inspect the cylinder for pitting, scoring, scuffing, and corrosion. If marks are found, the cylinder must be replaced.

■NOTE: Nickasil-plated cylinder cannot be honed.

Measuring Camshaft Runout

■NOTE: If the camshaft is out of tolerance, it must be replaced.

1. Place the camshaft on a set of V blocks; then position the dial indicator contact point against the shaft and zero the indicator.

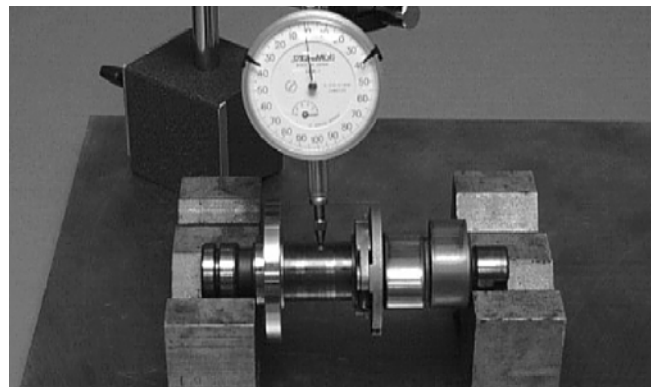

CC283D

2. Rotate the camshaft and note runout; maximum tolerance must not exceed specifications.

Measuring Camshaft Lobe Height

1. Using a calipers, measure each cam lobe height.

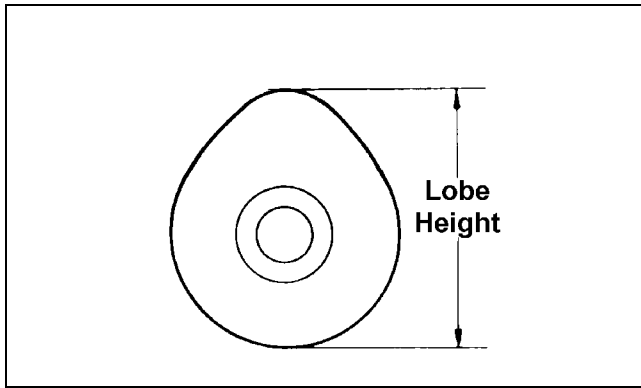

ATV1013A

2. The lobe heights must not exceed minimum specifications.

Inspecting Camshaft Bearing Journal

1. Inspect the bearing journal for scoring, seizure marks, or pitting.
2. If excessive scoring, seizure marks, or pitting is found, the cylinder head assembly must be replaced.

Measuring Camshaft to Cylinder Head Clearance

1. Place a strip of plastigauge in each of the camshaft lands in the cylinder head.
2. Install the camshaft journal caps on the cylinder head and secure with the cap screws. Tighten to specifications (see Section 10).

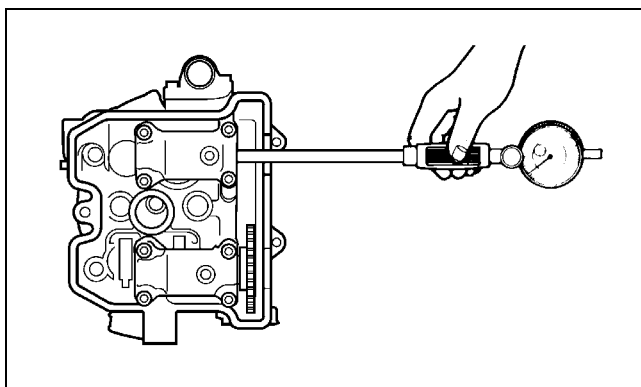

ATV2160

■NOTE: Do not rotate the camshaft when measuring clearance.

3. Remove the cap screws securing the journal caps to the cylinder head; then remove the journal caps and camshafts.
4. Match the width of the plastigauge with the chart found on the plastigauge packaging to determine camshaft to cylinder head journal clearance.

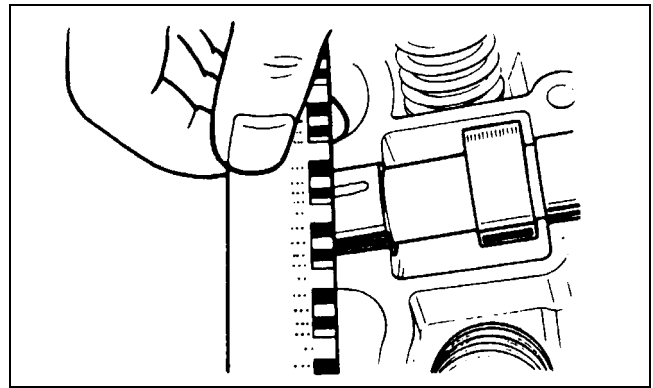

ATV2161

5. If clearance is excessive, measure the journals of the camshaft.

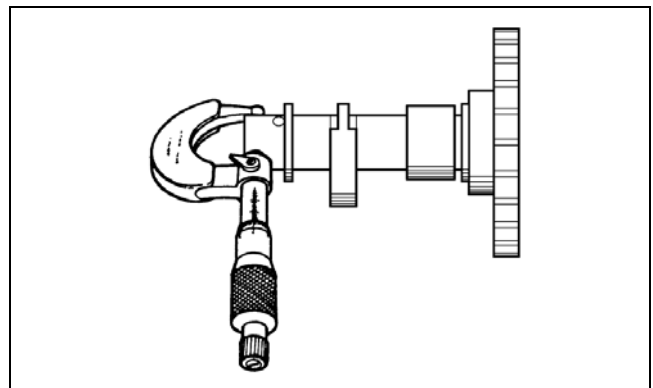

ATV2162

■NOTE: If the journals are worn, replace the camshaft; then measure the clearance again. If it is still out of tolerance, replace the cylinder head.

Inspecting Camshaft/Automatic Decompression Assembly

1. Move the automatic decompression weights by hand to check for freedom of movement. If the weights do not move smoothly or bind, the camshaft must be replaced.

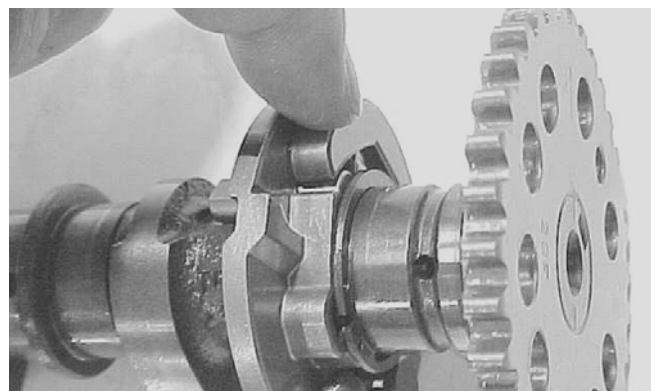

SP206

2. If damaged, the camshaft must be replaced.

Servicing Left-Side Components

STARTER CLUTCH

To replace the starter clutch, use the following procedure.

1. Hold the rotor/flywheel using a 27 mm offset wrench; then remove the six Allen-head cap screws securing the starter clutch housing.

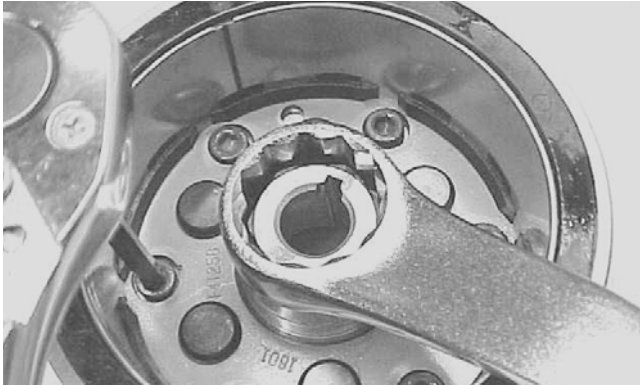

SP207

2. Install the new starter clutch making sure the flange side (A) is directed toward the rotor/flywheel; then install the six Allen-head cap screws and tighten securely. Apply engine oil to the starter clutch assembly.

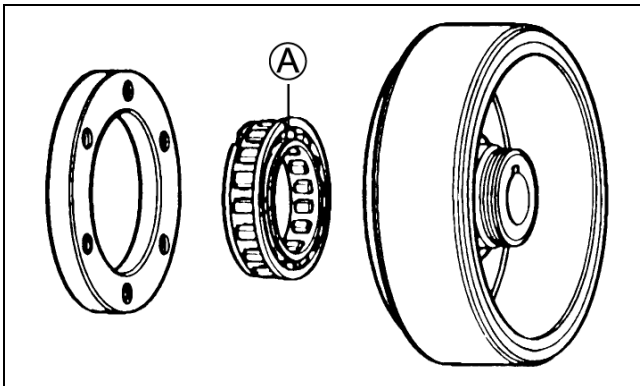

ATV2163



SP208

3. Install the starter driven gear (1) into the starter clutch; then check that the rotor (2) turns in the direction of the arrow (3) while holding the driven gear. Check in several positions and make certain the rotor never turns opposite the arrow.

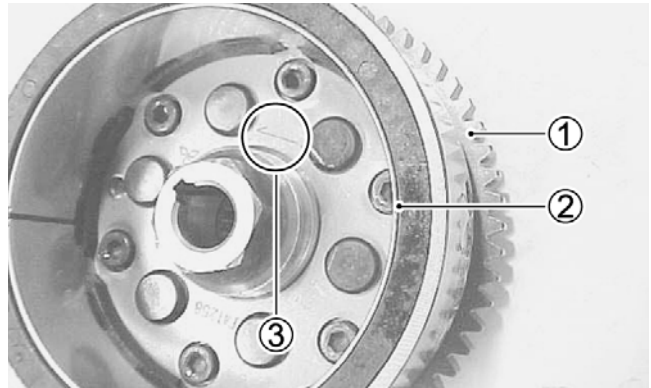

SP209

STARTER TORQUE LIMITER

■NOTE: Do not attempt to disassemble the starter torque limiter. It is not serviceable.

3

To check the slip-torque of the starter torque limiter, use a holding fixture, special socket, and a torque wrench as shown. If the slip-torque is not within 3.0-5.5 kg-m (22-40 ft-lb), replace the starter torque limiter.

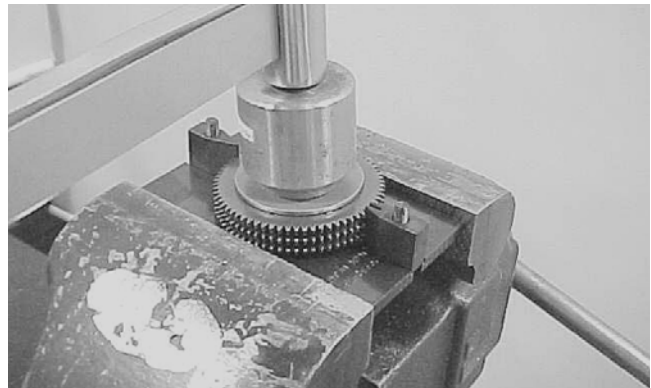

SP210

Servicing Right-Side Components

■NOTE: Whenever a part is worn excessively, cracked, damaged in any way, or out of tolerance, replacement is necessary.

PRIMARY CLUTCH ASSEMBLY (Inspecting/Measuring)

■NOTE: Prior to inspecting and measuring components, it is recommended that all components be removed from the primary driven gear assembly and be cleaned.

■NOTE: Keep all clutch components in order and set aside for assembly after the primary driven gear is installed on the driveshaft.

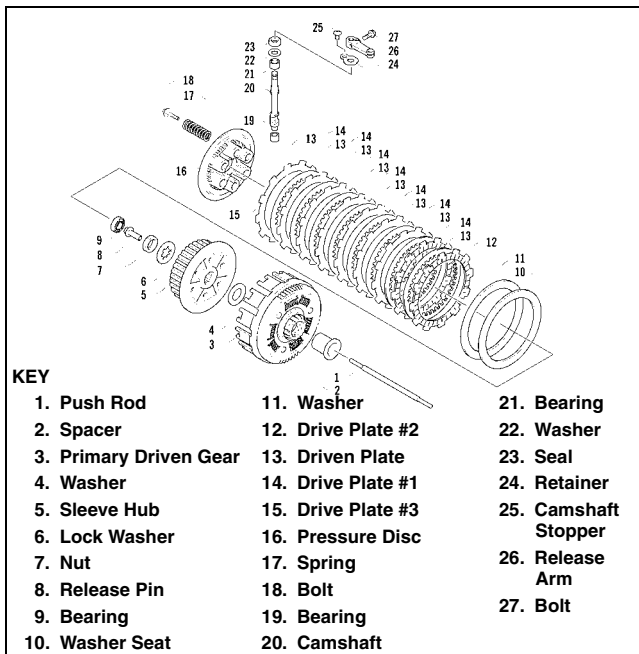

0741-474

Inspecting/Measuring Clutch Driven Plate Warpage

1. Inspect each driven plate for warpage and burn marks.
2. In turn place each driven plate on the surface plate; then using a feeler gauge, measure warpage in several locations.

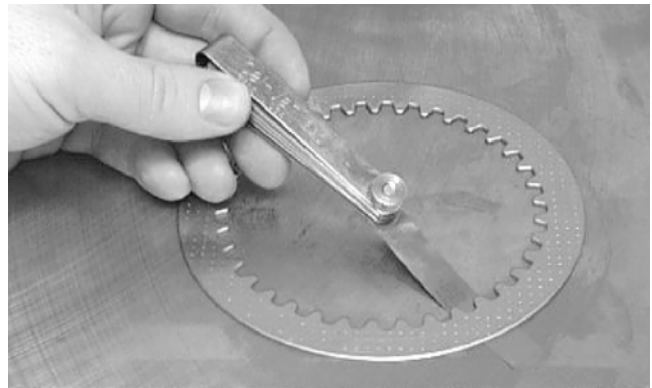

CC245D

3. Maximum driven plate warpage must not exceed specifications.

Measuring Clutch Drive Plate (Fiber) Thickness

1. Using a calipers, in turn measure the thickness of each drive plate in several locations.

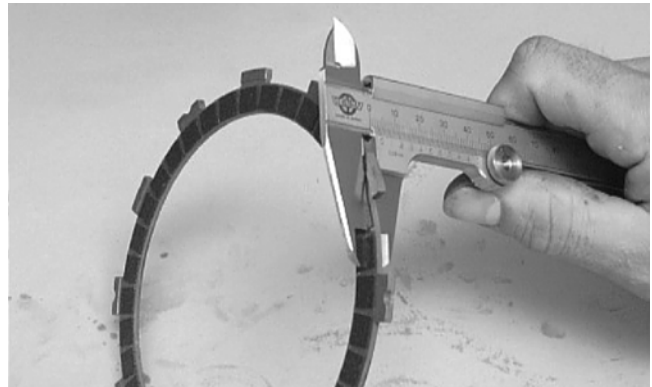

CC243D

2. Drive plate thickness must be within minimum specifications.
3. If the fiber plate tabs are damaged, the plate must be replaced.
4. Inspect the clutch sleeve hub for grooves or notches. If grooves or notches are present, replace the hub.

OIL PUMP (Inspecting/Servicing)

1. Remove the outer rotor (1), inner rotor (2), and the pin (4); then inspect the outer and inner rotors for nicks, scratches, or other damage. Replace any damaged parts.

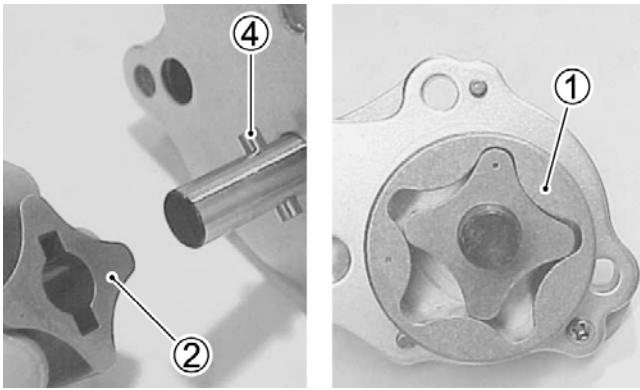

SP211A

■NOTE: Do not attempt to disassemble the oil pump housing assembly. It is serviceable only as a complete unit.

2. Apply engine oil to the mating surfaces of the inner and outer rotors; then align the groove (5) of the inner rotor with the pin (4) of the shaft and install the inner rotor.
3. Install the outer rotor.

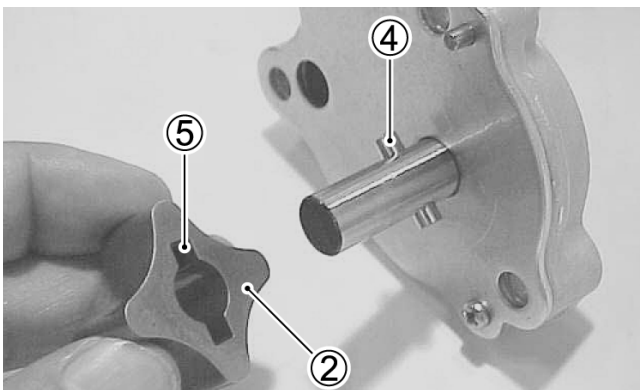

SP213

CRANK BALANCER DRIVEN GEAR

1. Remove the nut and large flat washer from the crank balancer shaft; then remove the driven gear.

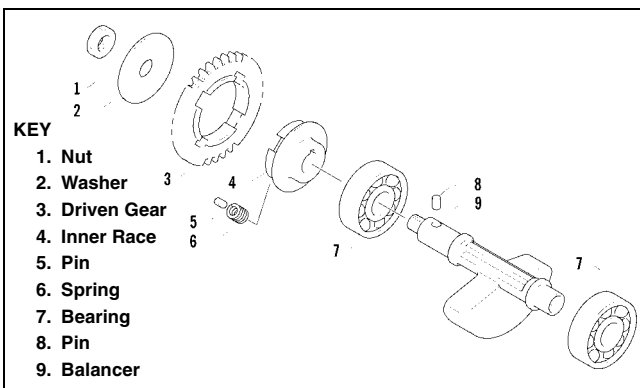

0739-185

2. Separate the driven gear from the driven gear inner race and account for four springs and two pins.

3. Measure the free length of the springs. If any spring free length is less than 10.3 mm (0.41 in.), replace all four springs.

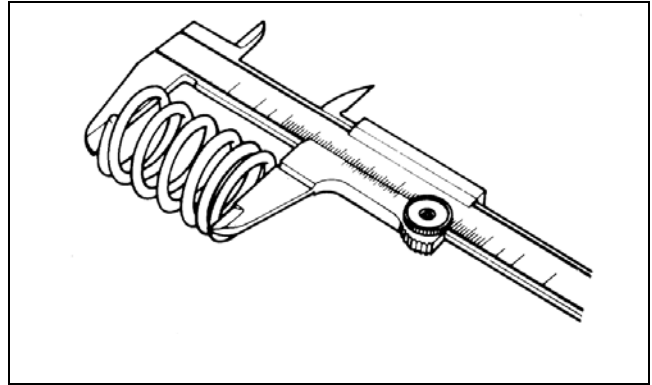

ATV2166

4. Assemble the balancer driven gear noting the position of the two pins (A) and alignment of the two punch marks.

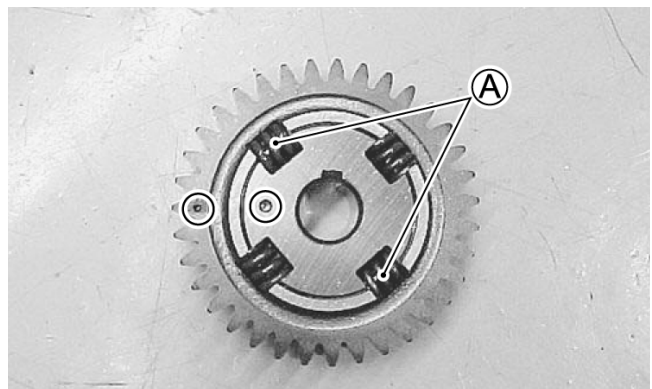

SP214

3

Servicing Center Crankcase Components

■NOTE: Whenever a part is worn excessively, cracked, damaged in any way, or out of tolerance, replacement is necessary.

CRANKCASE (Cleaning and Inspecting)

1. Remove the oil sump filter and clean using compressed air; then align the oil passage holes and install the sump filter.

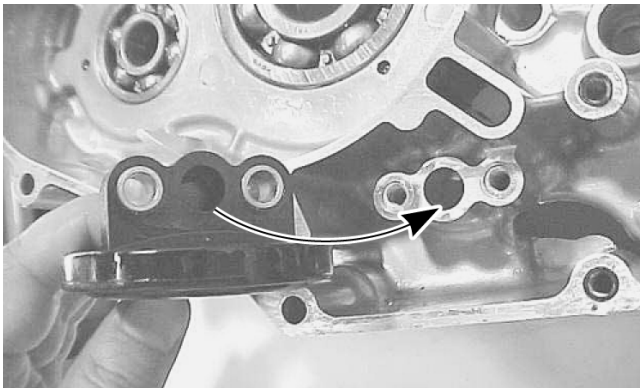

SP215

2. Remove the oil jet, install a new O-ring, apply engine oil, and install.

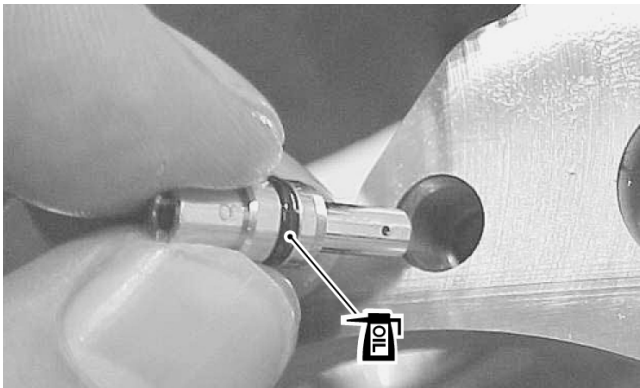

SP216

3. Install the oil pump idler gear shaft (1); then apply red Loctite #271 to the shift arm stopper (2) and tighten to specification (see Section 10).

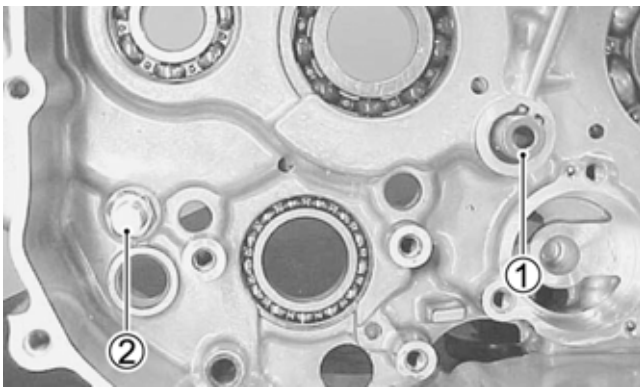

SP217

4. Wash the bearings with solvent and lubricate them with clean engine oil; then rotate the bearings by hand. If the bearings do not rotate smoothly and quietly, they must be replaced. Check for excessive radial and lateral play.

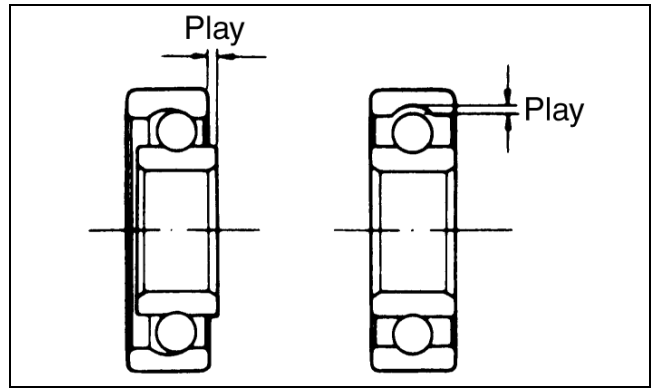

ATV2167

5. To replace a bearing, remove the bearing retaining screws; then use the bearing remover to pull the bearing from the crankcase.

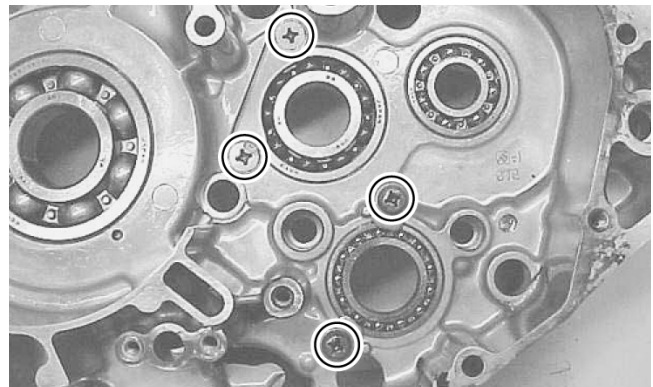

SP218

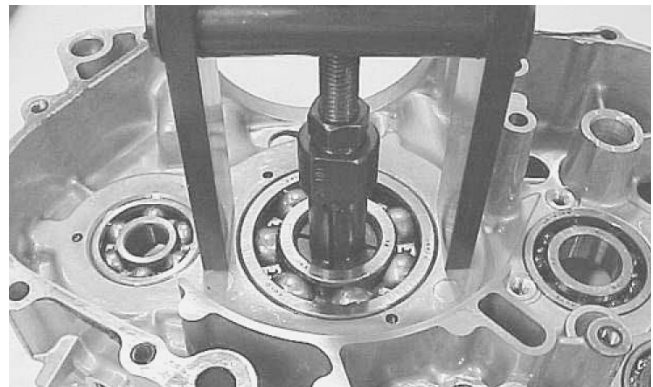

SP219

6. Install the new bearing using the bearing installer; then apply a small amount of red Loctite #271 to the bearing retainer screws and tighten securely.

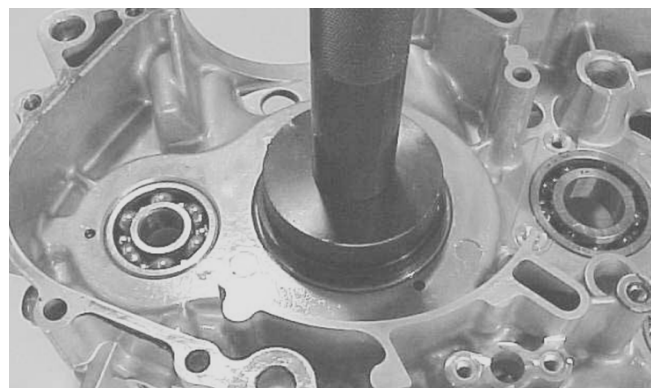

SP220

7. Inspect all the oil seals for wear, nicks, or lip damage. If any damage is found, replace the seal.
8. Thoroughly clean all crankcase mating surfaces prior to assembly.

CRANKSHAFT ASSEMBLY

Measuring Connecting Rod (Small End Inside Diameter)

1. Insert a snap gauge into the upper connecting rod small end bore; then remove the gauge and measure it with micrometer.

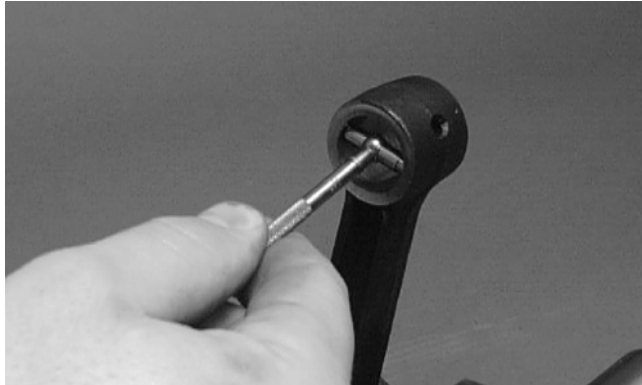

CC290D

2. Maximum diameter must not exceed specifications.

Measuring Connecting Rod (Small End Deflection)

1. Place the crankshaft on a set of V-blocks and mount a dial indicator and base on the surface plate. Position the indicator contact point against the center of the connecting rod small end journal.
2. Zero the indicator and push the small end of the connecting rod away from the dial indicator.
3. Maximum deflection must not exceed specifications.

Measuring Connecting Rod (Big End Side-to-Side)

1. Push the lower end of the connecting rod to one side of the crankshaft journal.
2. Using a feeler gauge, measure the gap between the connecting rod and crankshaft journal.

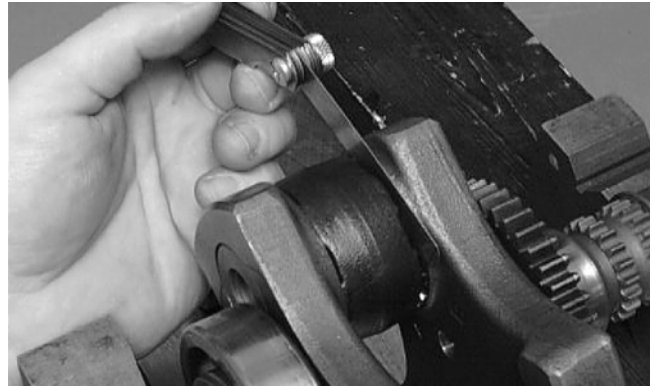

CC289D

3. Acceptable gap range must be within specifications.

Measuring Connecting Rod (Big End Width)

1. Using a calipers, measure the width of the connecting rod at the big-end bearing.
2. Acceptable width range must be within specifications.

3

Measuring Crankshaft (Runout)

1. Place the crankshaft on a set of V blocks.
2. Mount a dial indicator and base on the surface plate. Position the indicator contact at point 1 of the crankshaft.

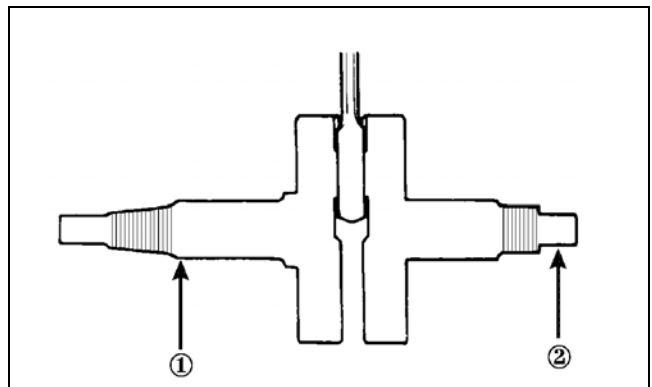

ATV-1074

3. Zero the indicator and rotate the crankshaft slowly.

CAUTION

Care should be taken to support the connecting rod when rotating the crankshaft.

4. Maximum runout must not exceed specifications.

■NOTE: Proceed to check runout on the other end of the crankshaft by positioning the indicator contact at point 2 and following steps 2-4.

Measuring Crankshaft (Web-to-Web)

- Using a calipers, measure the distance from the outside edge of one web to the outside edge of the other web.

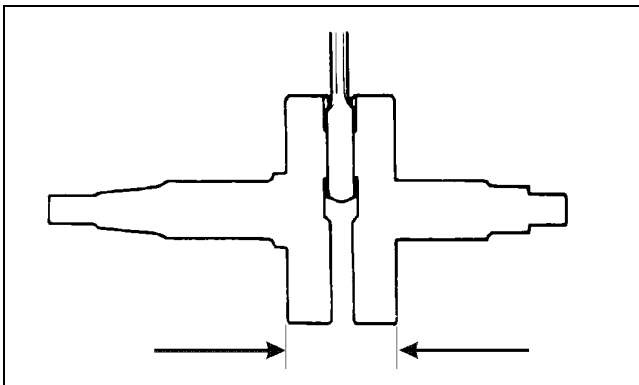

ATV-1017

- Acceptable width range must be within specifications.

DRIVESHAFT

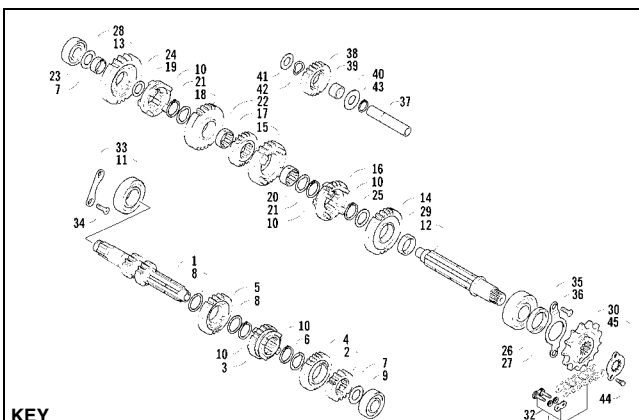

KEY

- | | | |
|----------------------|--------------------------|------------------------|
| 1. Countershaft | 17. Gear, 5th Driven | 32. Joint Set |
| 2. Gear, 2nd Drive | 18. Gear, Reverse Driven | 33. Retainer |
| 3. Gear, 3rd Drive | 19. Reverse Dog | 34. Screw |
| 4. Gear, 4th Drive | 20. Bushing | 35. Retainer |
| 5. Gear, 5th Drive | 21. Washer | 36. Bolt |
| 6. Washer | 22. Bushing | 37. Reverse Idle Shaft |
| 7. Washer | 23. Bearing | 38. Reverse Idle Gear |
| 8. Washer | 24. Washer | 39. Bushing |
| 9. Bearing | 25. Washer | 40. Washer |
| 10. Circlip | 26. Bearing | 41. Washer |
| 11. Bearing | 27. Oil Seal | 42. Wave Washer |
| 12. Driveshaft | 28. Bushing | 43. Circlip |
| 13. Gear, 1st Driven | 29. Bushing | 44. Bolt |
| 14. Gear, 2nd Driven | 30. Engine Sprocket | 45. Plate |
| 15. Gear, 3rd Driven | 31. Chain Assy | |
| 16. Gear, 4th Driven | | |

0739-226

Disassembling

- In order, remove the washer, 1st driven gear, and bushing from the driveshaft.
- Remove the 1st driven washer (right side); then remove the reverse dog from the driveshaft.

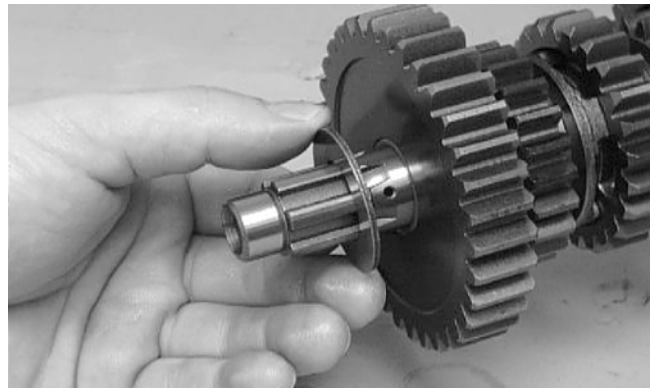

CC223D

■NOTE: Note the orientation of the four small dogs and the 1st driven gear for assembling purposes.

- Remove the reverse circlip; then remove the reverse washer (left side) from the splined shaft.
- Remove the reverse driven gear from the drive-shaft.
- Remove the reverse driven bushing; then remove the 5th driven gear from the driveshaft.
- Remove the 3rd driven gear, bushing, and washer from the driveshaft.
- Remove the 4th driven circlip and gear from the driveshaft.
- In order, remove the 2nd driven circlip, washer, gear, and bushing from the driveshaft.

Measuring Shift Fork/Gear

Measure the shift fork clearance in the groove of the mating gear using a feeler gauge. If the clearance exceeds specifications, proceed as follows.

- Using a calipers, measure the shift fork groove width. If it is not within specifications, the gear must be replaced.
- Using a calipers, measure the shift fork thickness. If it is not within specifications, the shift fork must be replaced.

■NOTE: After a circlip has been removed from a shaft, it should be discarded and replaced with a new one.

■NOTE: When assembling the transmission shafts, attention must be given to the position of the washers and circlips. The cross-sectional view shows the correct position of the gears, washers, and circlips.

Assembling

- In order, install the 2nd driven bushing, gear, washer, and circlip onto the driveshaft.

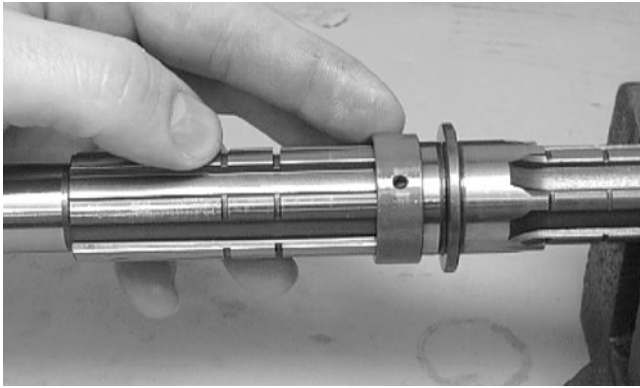

CC206D

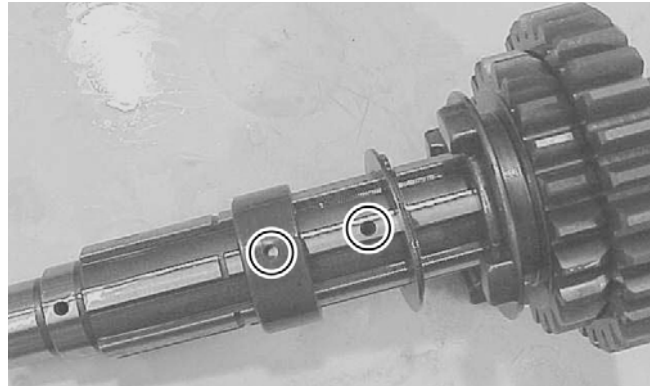

SP221



CC207D

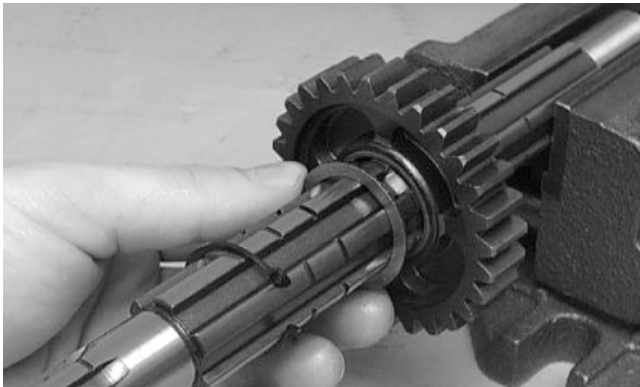

CC208D



CC209D

2. Install the 4th driven gear onto the driveshaft.
3. Install the 3rd driven circlip, washer, and bushing onto the driveshaft. Make sure the oil hole in the bushing aligns with the hole in the shaft.

⚠ CAUTION
 It is very important to assure the oil feed hole in the bushing and oil supply hole in the driveshaft align. If not aligned, engine damage will result.

4. Install the 3rd driven gear onto the driveshaft.

3

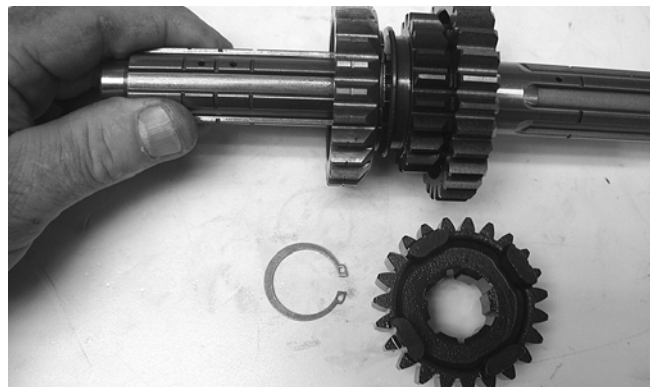

CD366

5. Install the 5th driven gear onto the driveshaft.
6. In order, install the reverse driven bushing, reverse driven gear, washer, and circlip onto the drive shaft. Make sure the oil hole in the reverse driven bushing aligns with the hole in the shaft.

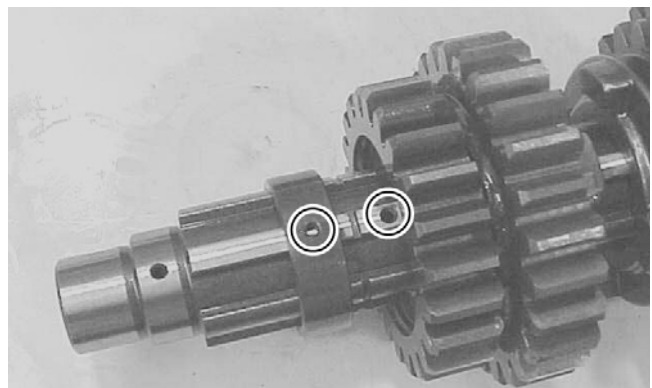

SP222

⚠ CAUTION
 It is very important to assure the oil feed hole in the bushing and oil supply hole in the driveshaft align. If not aligned, engine damage will result.

7. Install the reverse dog onto the driveshaft making sure the four small dogs are facing toward the 1st driven gear as noted in disassembling.
8. Install the 1st driven washer (right side) onto the shoulder of the splined shaft; then install the 1st driven bushing and gear.



CC221D

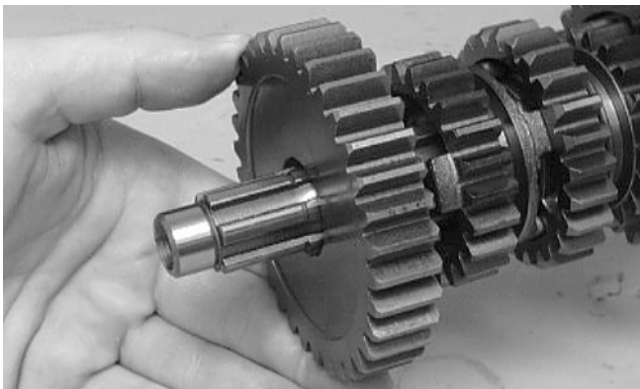

CC222D

9. Install the 1st driven washer (left side) on the driveshaft.

■NOTE: The driveshaft is now completely assembled for installation.

COUNTERSHAFT

Disassembling

1. Remove the 2nd drive gear and washer from the countershaft.



CC204D

2. Remove the 4th drive gear from the countershaft.

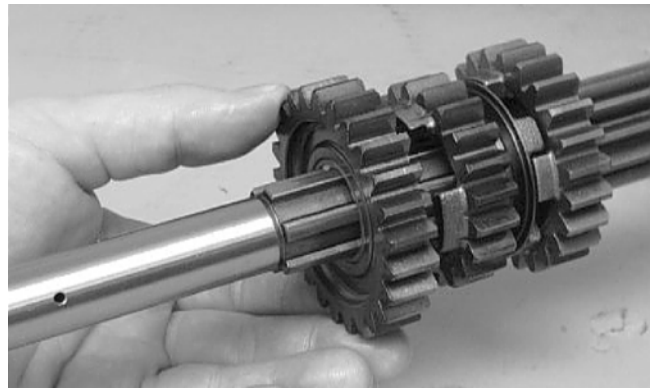

CC203D

3. Remove the 4th drive washer and 4th drive circlip from the countershaft.

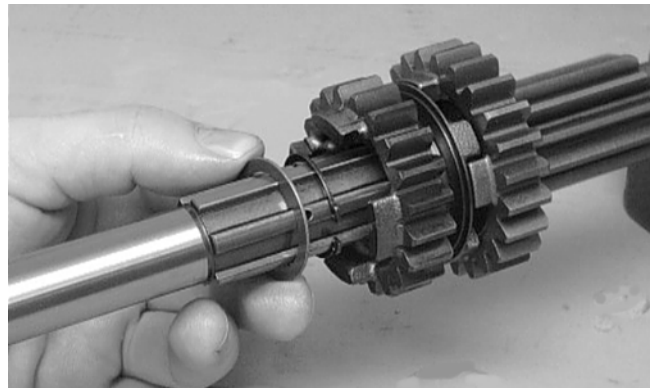

CC201D

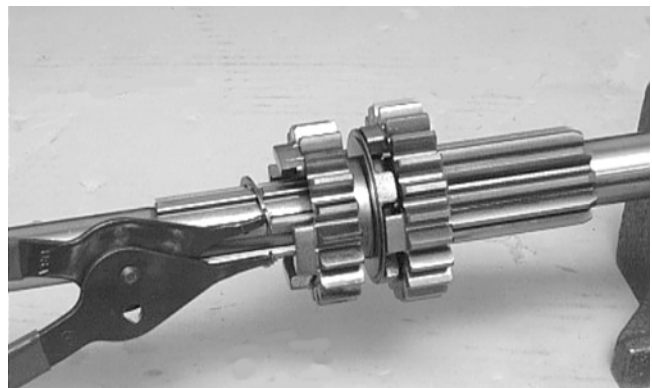

CC200D

4. Remove the 3rd drive gear from the countershaft.
5. Remove the 5th drive circlip securing the 5th drive gear on the countershaft; then remove the first 5th drive washer and 5th drive gear.

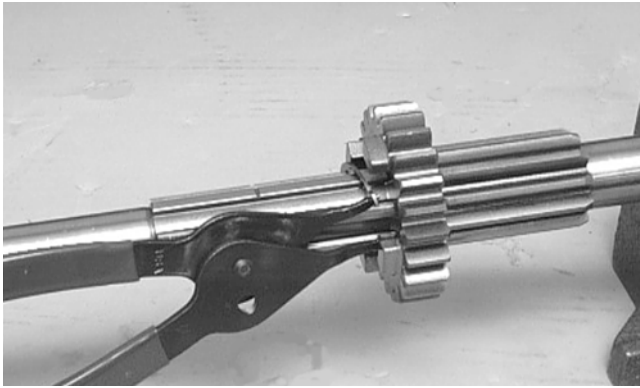

CC199D

6. Remove the remaining 5th drive washer from the countershaft.

Assembling

1. Install the first 5th drive washer onto the countershaft.
2. Install the 5th drive gear; then install the second 5th drive washer onto the countershaft. Secure with the circlip.

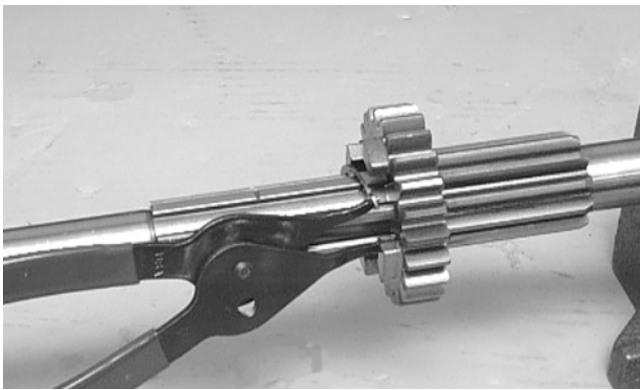

CC199D

3. Install the 3rd drive gear; then install the 4th drive circlip onto the countershaft.

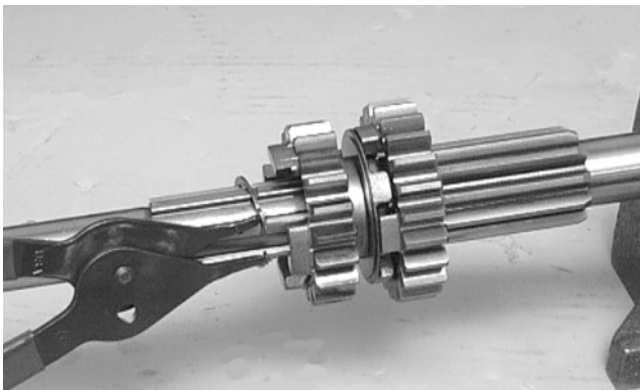

CC200D

4. Install the 4th drive washer and 4th drive gear onto the countershaft.

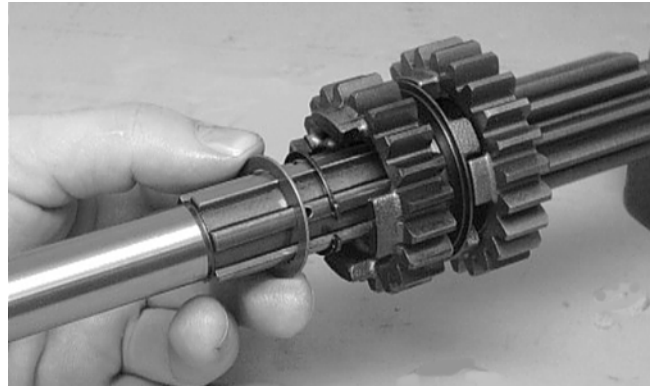

CC201D

5. Install the 2nd drive gear and washer onto the countershaft.

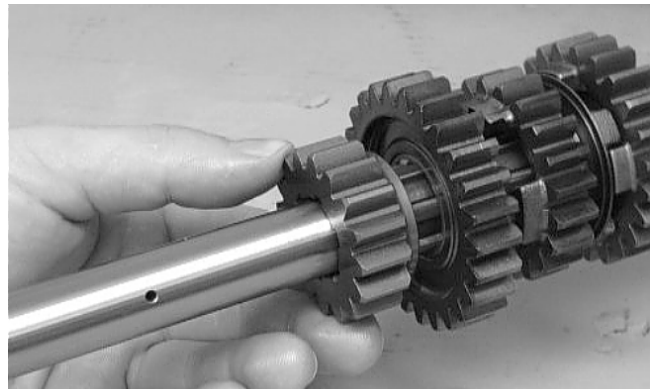

CC204D

■NOTE: The countershaft is now completely assembled for installation.

3

Assembling Crankcase Half

■NOTE: For ease of assembly, install components on the left-side crankcase half.

1. Install the left end of the crankshaft into the crankcase using the appropriate crankshaft installer tool.

■NOTE: Never fit the crankshaft into the crankcase by striking it with a plastic mallet as the accuracy of the crankshaft alignment may be affected.

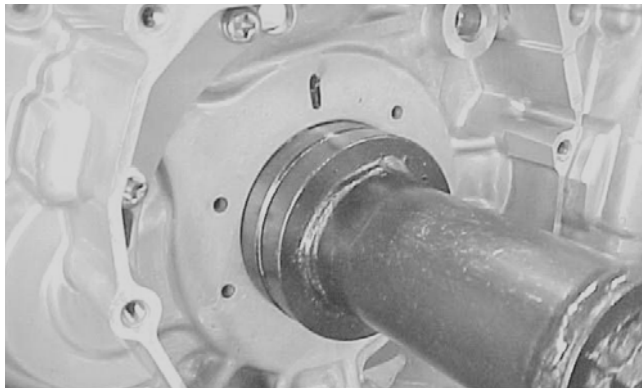

SP223

2. Install the crank balancer shaft.
3. Simultaneously, install the driveshaft and countershaft assemblies making sure the washer is on the countershaft.
4. Making sure the circlip is in position, install the reverse idler shaft; then install a washer, bushing, reverse idler gear, wave washer, and thrust washer.
5. Place each of the three shift forks into its respective gear or dog (1) (2) (3) as noted during disassembling.

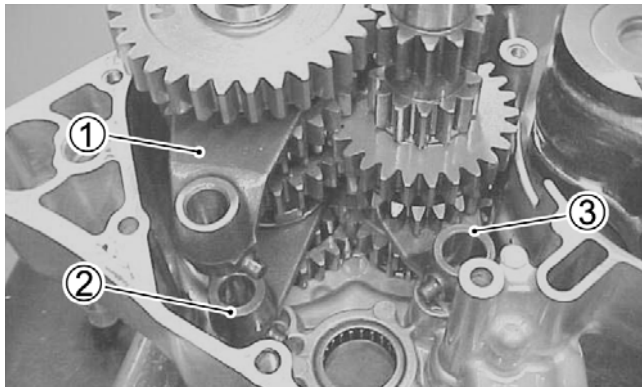

SP224

6. Install the shift cam (4); then install the shift fork shaft (5) and the reverse lock shaft (6).

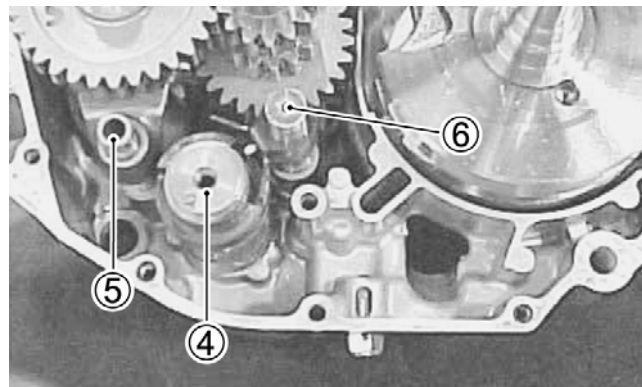

SP225

■NOTE: Check to be sure that the gears all engage normally; then shift the transmission into neutral.

7. Verify that the two crankcase half alignment pins (1) are in place.

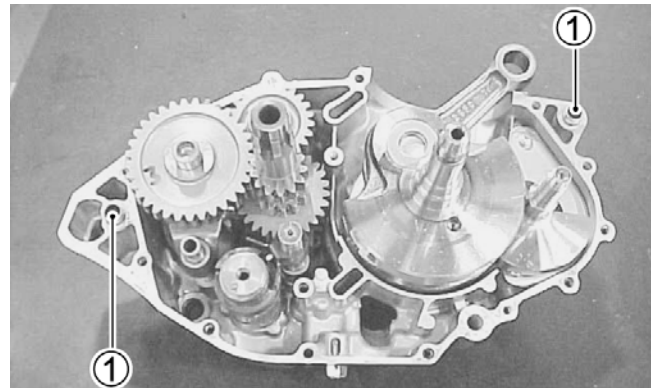

SP226

Joining Crankcase Halves

1. Verify that the washer is on the reverse idler shaft; then apply Three Bond Sealant to the mating surfaces. Place the right-side half onto the left-side half.

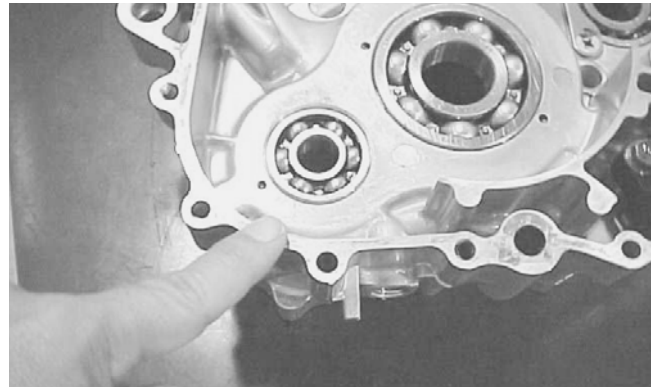

SP227

2. Using a plastic mallet, lightly tap the case halves together until cap screws can be installed.
3. From the left side, install the six case half cap screws; then tighten only until snug.

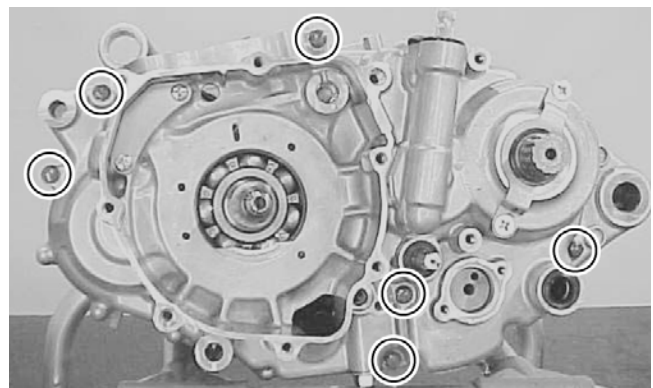

SP228

■NOTE: Rotate the shafts back and forth to ensure no binding or sticking occurs.

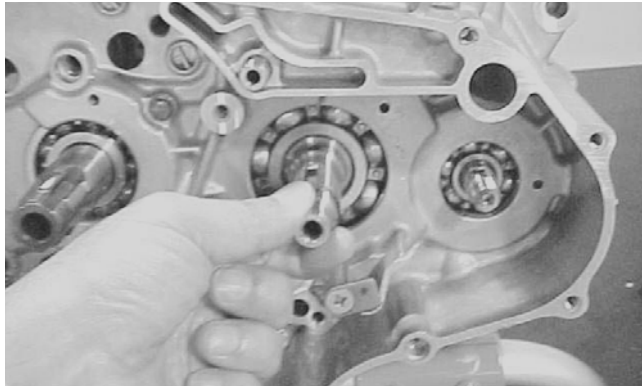

SP230

4. From the right side, install the eight case half cap screws (three inside the case); then tighten only until snug.

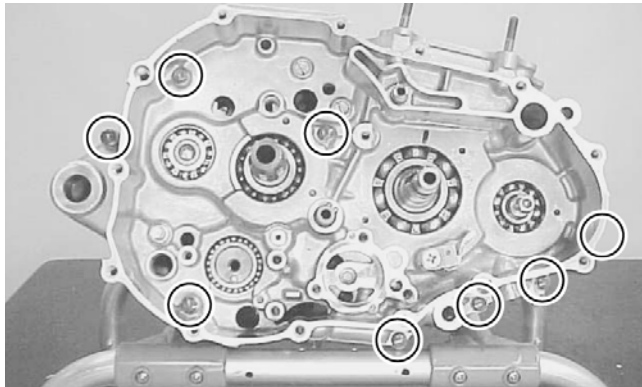

SP229

■NOTE: Rotate the shafts back and forth to ensure no binding or sticking occurs.

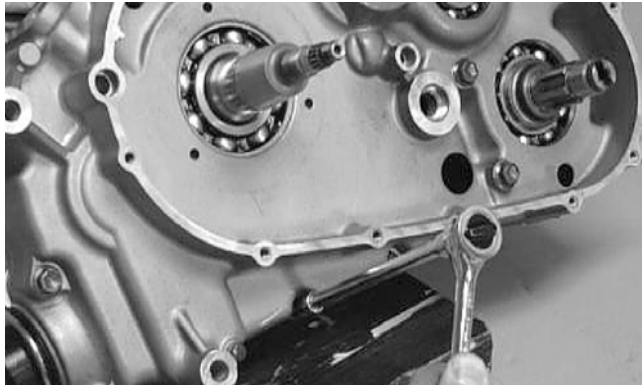

CC095D

5. In a crisscross/case-to-case pattern, tighten the cap screws (from steps 3-4) until the halves are correctly joined; then tighten to specifications (see Section 10).

■NOTE: Rotate the shafts back and forth to ensure no binding or sticking occurs.

Installing Right-Side Components

■NOTE: Critical torque specifications are located in Section 10.

- A. Primary Drive Gear
- B. Crank Balancer Gear
- C. Cam Chain

■NOTE: It will be necessary to install the starter driven gear, starter one-way clutch, and the rotor/flywheel on the left side prior to installing right-side components. This is done to provide a means of holding shafts for tightening right-side shaft nuts.

1. Install the starter driven gear (1) and the key (2); then clean any oil or grease from the tapered portion of the crankshaft and from inside the rotor/flywheel tapered bore.

3

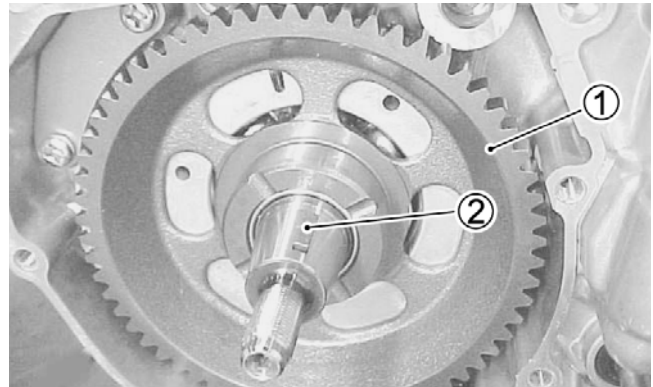

SP231

2. Align the keyway with the key and install the rotor/flywheel; then using an offset 27 mm wrench, hold the flywheel and tighten the nut to specifications.



SP232

3. Install the pins (1); then install the crank balancer drive gear (2). Install the key (3) and cam chain drive sprocket (4).

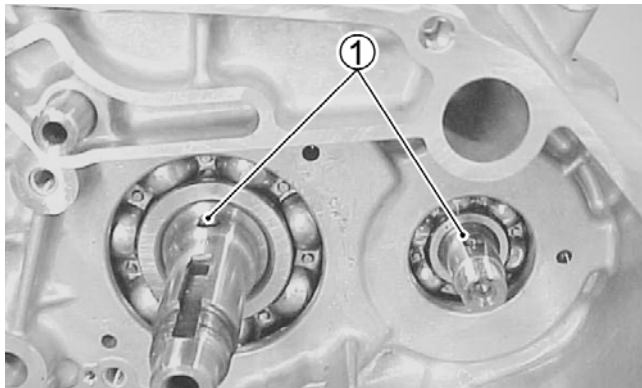

SP233



SP235A

6. Install the crank balancer driven gear (5) aligning the timing marks (6); then holding the generator rotor with a 27 mm offset wrench, tighten the crank balancer driven gear nut to specifications.

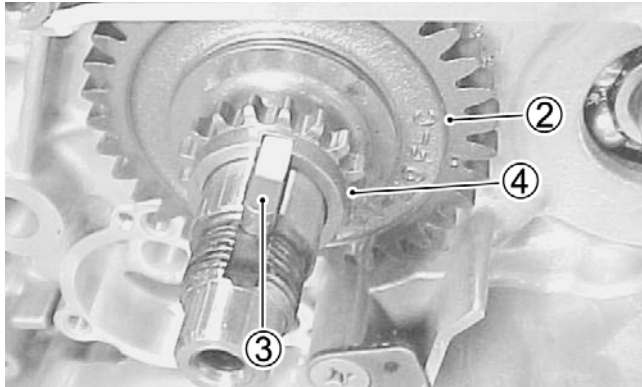

SP234

4. Install the cam chain (1) onto the sprocket; then install the cam chain tensioner and tighten the mounting bolt (2) to specifications.

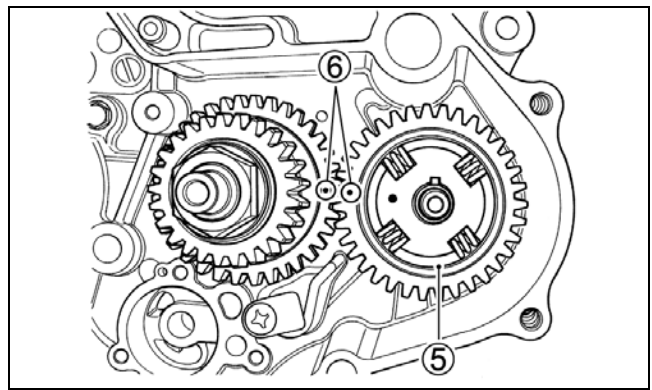

ATV2169

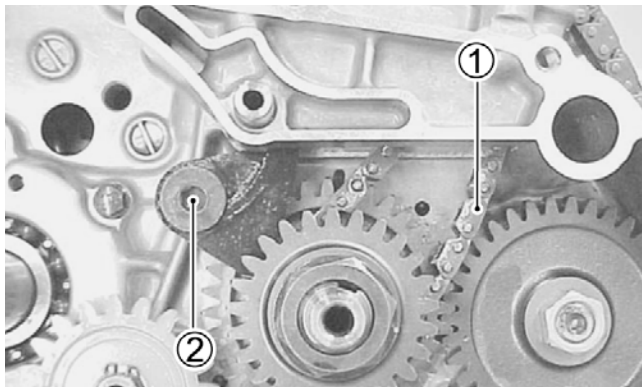

SP251

5. Apply engine oil to the threads; then install the primary drive gear and nut and while holding the generator rotor with a 27 mm offset wrench, tighten to specifications.

D. Shift Cam Driven Gear E. Oil Pump

■NOTE: Steps 1-6 in the preceding sub-section must precede this procedure.

7. Install the shift cam driven gear bolt and tighten to specifications.

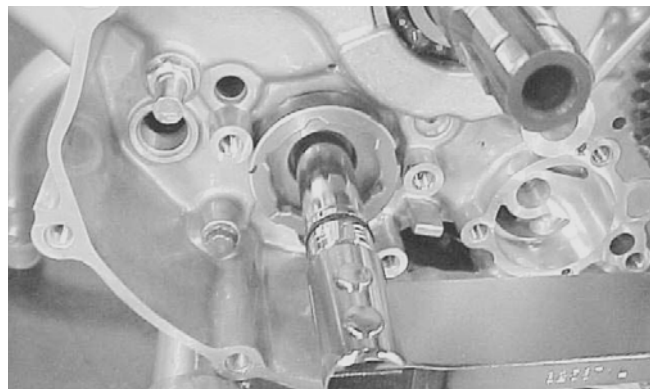

SP237

8. Install each pawl lifter into the shift cam driven gear with the large shoulder (A) directed to the outside; then apply a small amount of red Loctite #271 to the pawl lifter screws and tighten them securely.

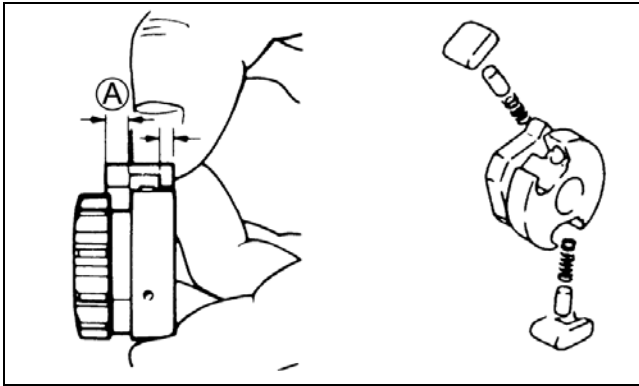

ATV2170A

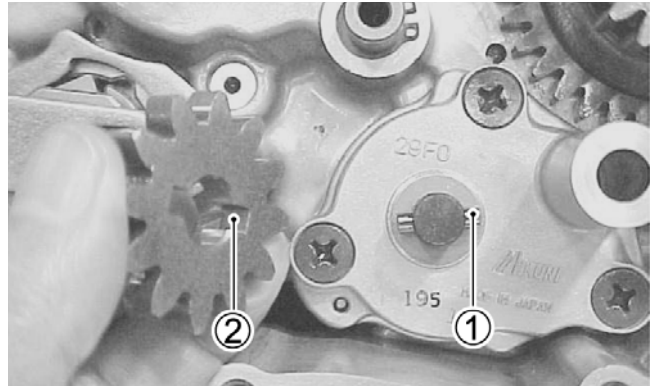

SP241

11. Install the oil pump idler gear and secure with a circlip.

F. Oil Pipe
G. Clutch

■NOTE: Steps 1-11 of the preceding sub-sections must precede this procedure.

3

12. Apply engine oil to the O-rings on the oil pipe; then install and tighten the hold-down bolt securely.

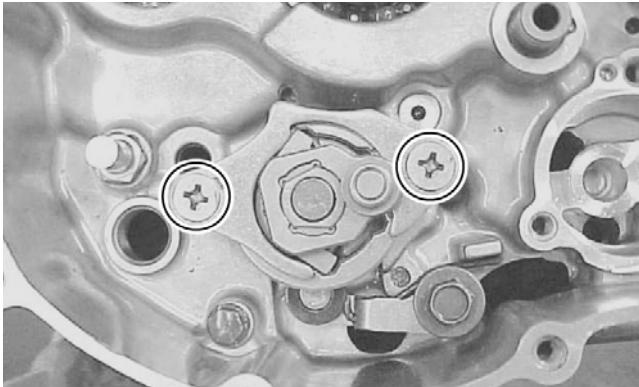

SP242

9. Apply engine oil to the moving parts of the oil pump and all mating surfaces.

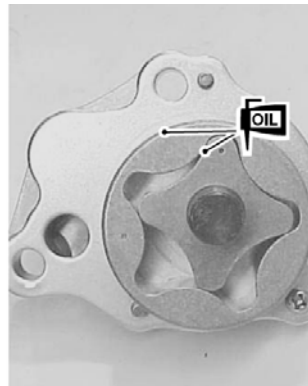
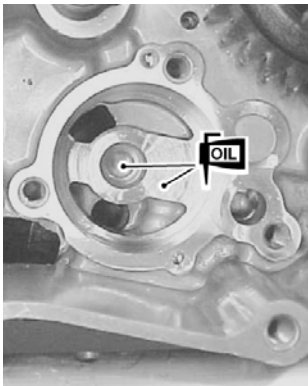

SP238A

10. Apply red Loctite #271 to the oil pump mounting screws and tighten securely; then install the oil pump driven gear aligning the pin (1) with the groove (2) and install the circlip.

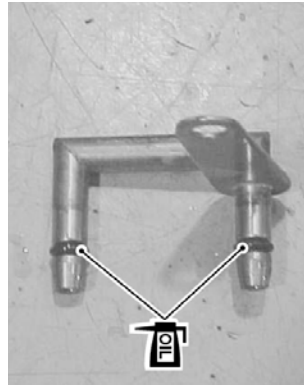

SP243A

13. Install the collar (3), primary driven gear assembly (1), washer (2), clutch sleeve hub, and clutch sleeve hub nut on the driveshaft.

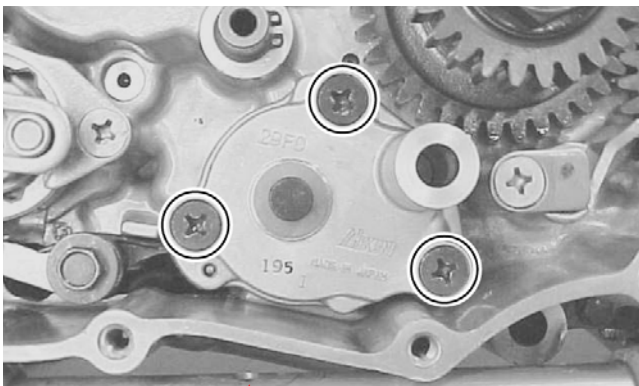

SP240

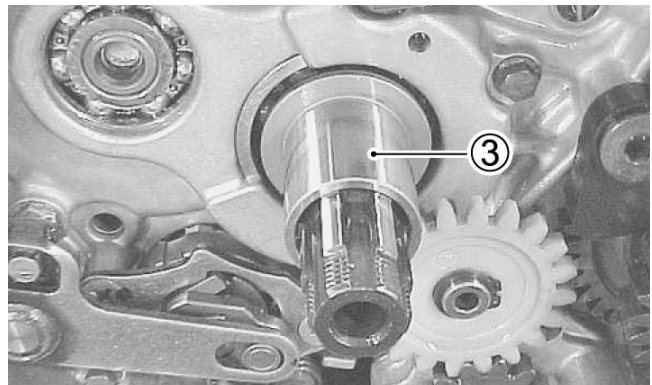

SP162

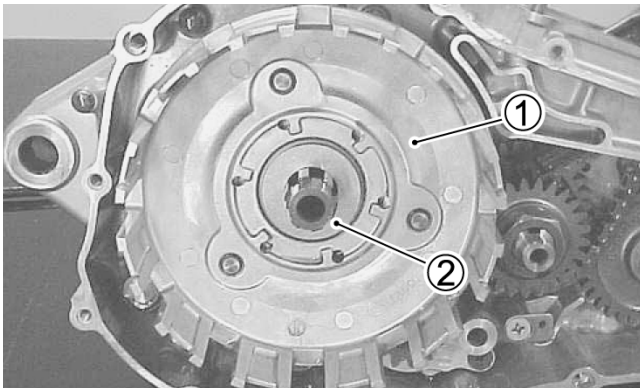

SP161

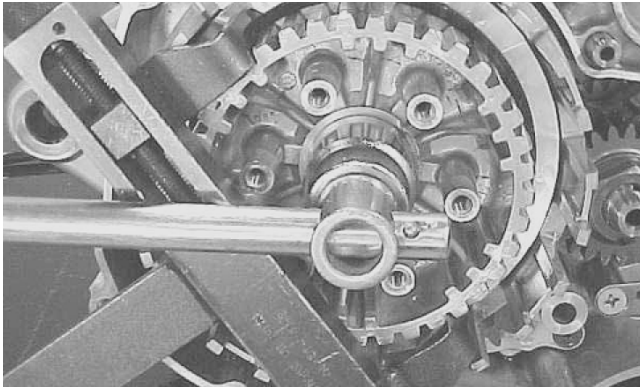

SP160

14. Using the special holding tool, hold the clutch sleeve hub and tighten nut to specifications.

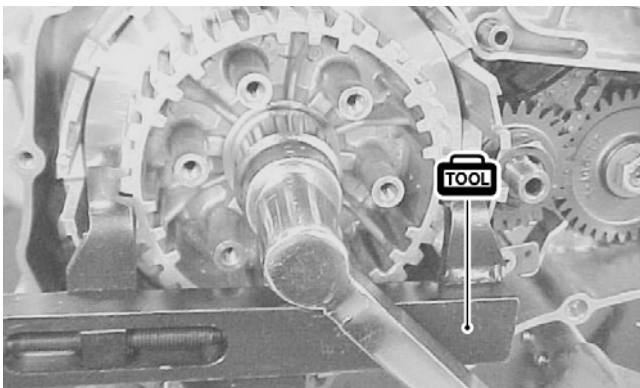

SP245

15. Bend the washer over securely engaging the flat of the nut.

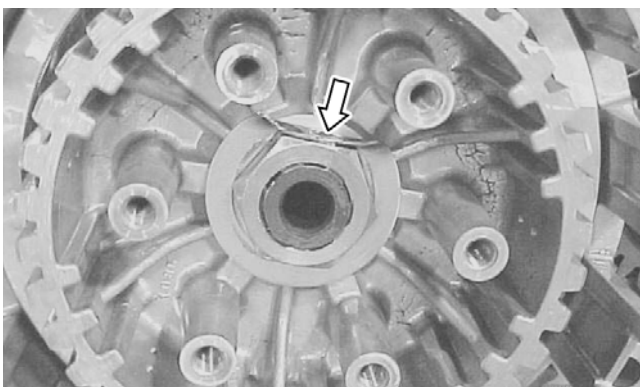

SP246

16. Install the drive and driven plates one by one into the clutch hub sleeve in the prescribed order.

■NOTE: Be sure to install the drive plate with the inside diameter of 122.5 mm (4.82 in.) first. Two different types of drive plates are used. They are the one with the 122.5 mm (4.82 in.) inside diameter and seven with an inside diameter of 116.0 mm (4.5 in.).



SP247

17. Install the push rod (2), clutch release pin (1), and washer (3); then install the pressure disc and tighten the clutch spring set bolts in stages using the illustrated pattern.

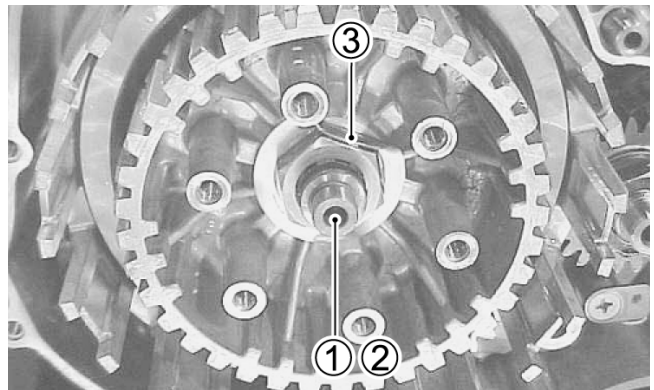

SP159



SP248

18. Install the alignment pins (1) and a new gasket (2); then install the clutch cover using a new washer gasket at position (1). Tighten the cap screws securely.

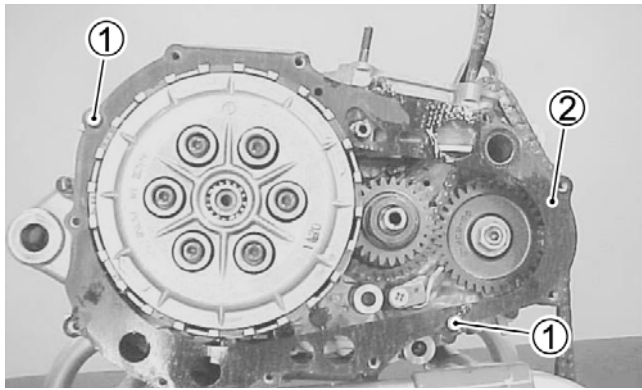

SP249

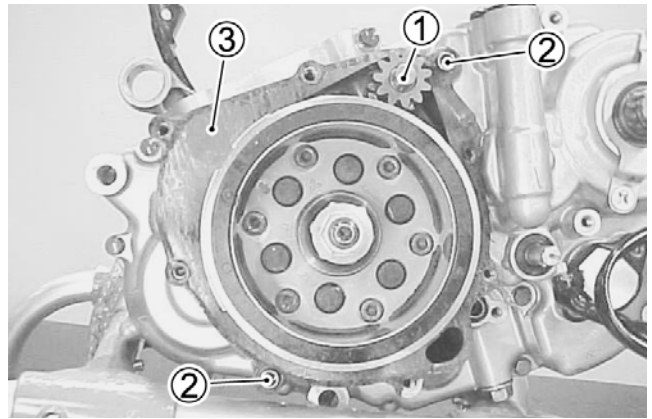

SP254

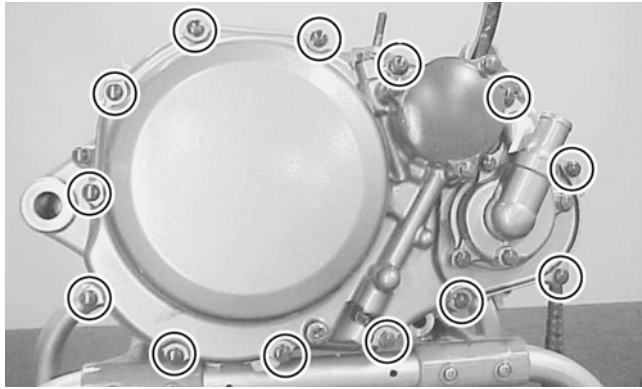

SP250

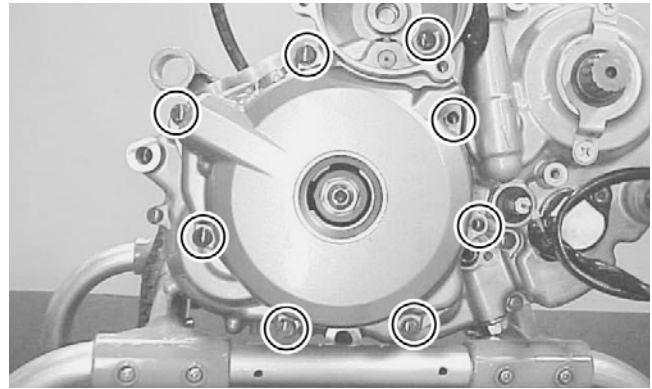

SP255

Installing Left-Side Components

■NOTE: Critical torque specifications are located in Section 10.

- A. Neutral Switch
- B. Starter Driven Gear

1. Install the springs (1), contacts (2), and a new O-ring (3); then install the neutral switch and tighten the Allen-head cap screws to specifications.

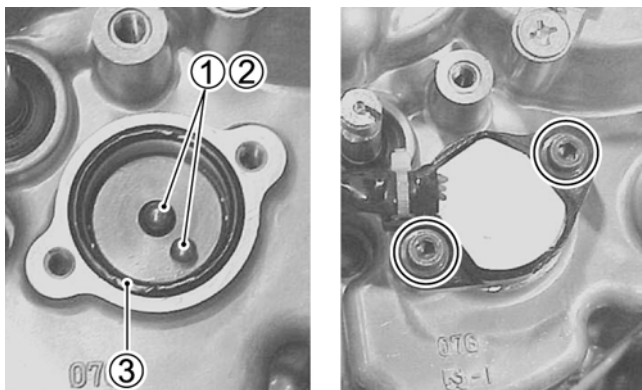

SP252A

2. Install the starter driven gear (1), dowel pins (2), and a new gasket (3); then install the cover and tighten the cap screws securely.

Installing Top-Side Components

■NOTE: Critical torque specifications are located in Section 10.

- A. Piston
- B. Cylinder

■NOTE: If the piston rings were removed, install them in this sequence.

1. Install the spacer (3) into the oil ring groove; then install the two side rails (4).

■NOTE: The spacer and side rails do not have a top and bottom designation. Do not allow the spacer ends to overlap. B is correct.

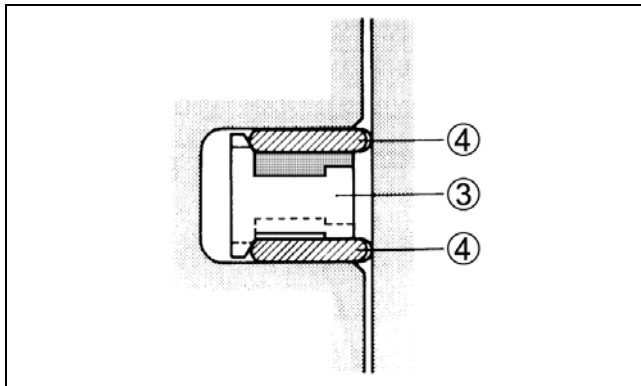

ATV2173

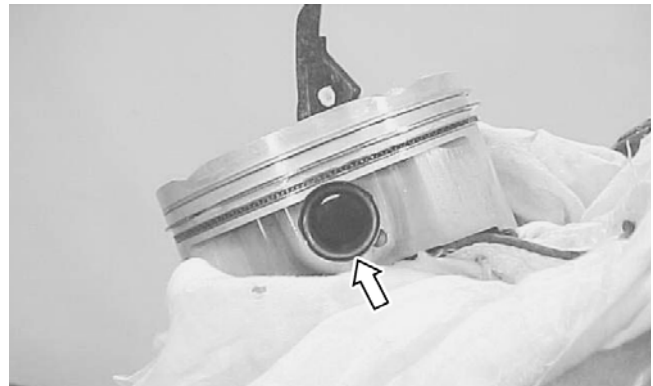

SP256

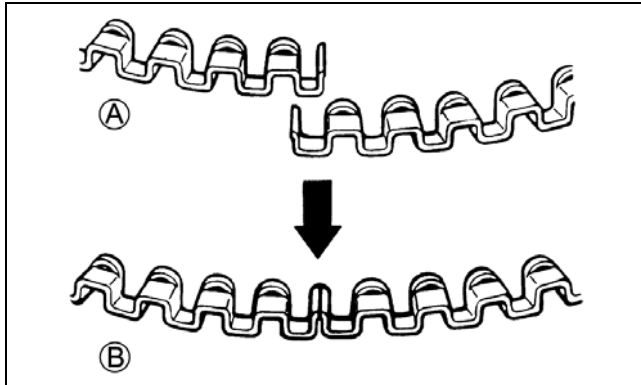

ATV2174

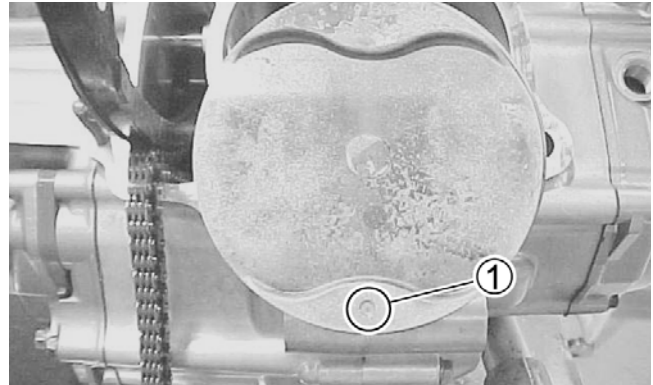

SP257

■NOTE: The first (1) and second (2) rings differ in shape. Install the rings with the mark directed up.

2. Install the second ring (2); then install the first ring (1).

5. Apply engine oil to the sliding surface of the piston and the big end of the connecting rod; then install the alignment pins (2) and a new gasket (3) onto the crankcase.

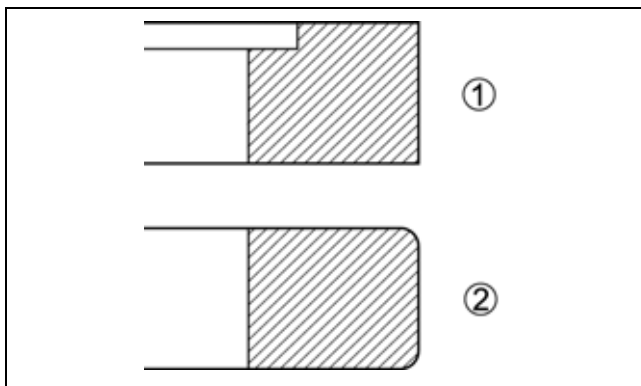

ATV2175

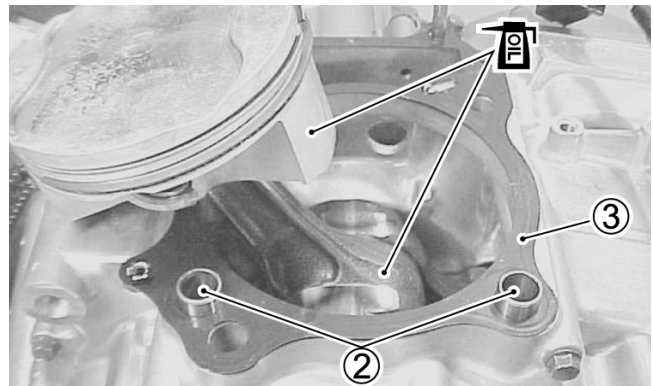

SP258

3. Apply engine oil onto the piston pin and the small end of the connecting rod.

4. Place a clean rag over the cylinder base to prevent the piston-pin circlip from dropping into the crankcase; then install the piston, piston pin, and a new circlip with the punch mark (1) on the piston directed toward the exhaust side.

6. Position each piston ring correctly and work the cylinder down onto the piston making sure the rings do not catch on the cylinder skirt.

■NOTE: To correctly position the end gaps with (A) being the exhaust, position (5) is the 2nd ring and lower side rail, position (6) is the upper side rail, and position (7) is the 1st ring and spacer.

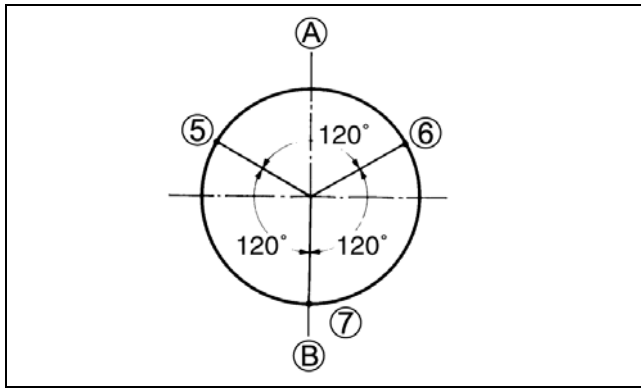

ATV2176

■NOTE: When mounting the cylinder after installing the camshaft drive chain, be sure to keep the drive chain taut. The drive chain must not be allowed to catch between the cam drive chain sprocket and the crankcase when the crankshaft is rotated.



SP259

7. Install the cam chain guide (1) ensuring that the guide is installed properly; then install the alignment pins (2) and a new gasket (3).

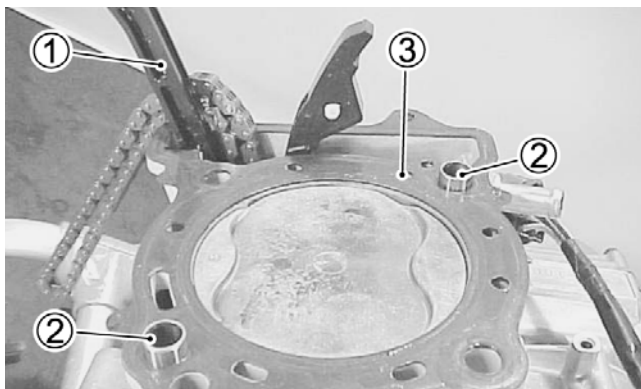

SP260

■NOTE: Always use a new cylinder head gasket to prevent leakage.

C. Cylinder Head
D. Camshafts
E. Valve Cover
F. Cam Chain Tensioner

■NOTE: Steps 1-7 of the preceding sub-section must precede this procedure.

8. Install the cylinder head on the cylinder.
9. Lightly oil the threads of the 10 mm cap screws and the washers; then install and tighten in two steps to specifications using a diagonal pattern.

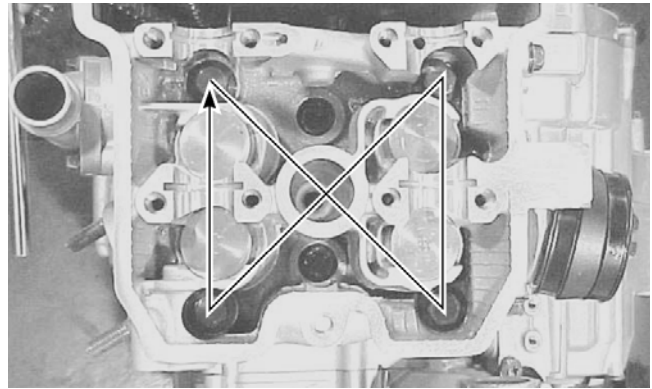

SP261

10. Tighten the two 6 mm cap screws (1) and cylinder nuts (2) to specifications.

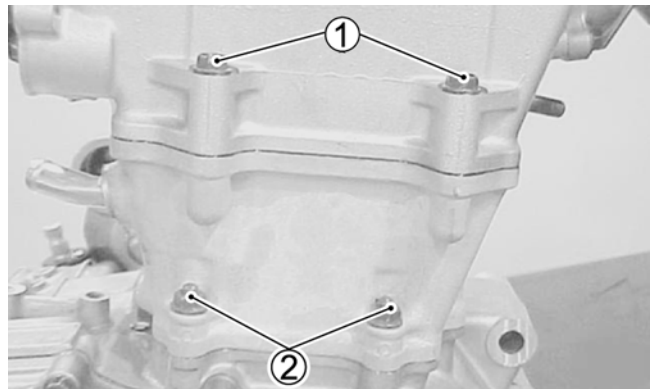

SP262

11. Turn the rotor/flywheel until the "T" line on the rotor is aligned with the center of the timing hole in the cover.

■NOTE: If the crankshaft is turned without holding the cam chain taut, the chain will catch between the crankcase and the cam chain drive sprocket.

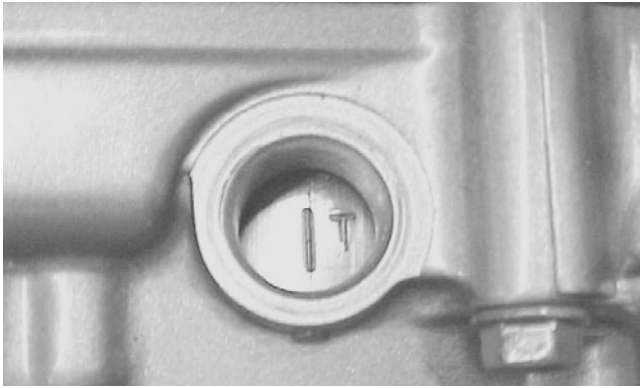

SP263

12. Apply molybdenum oil solution to the camshaft journals, camshaft lobes, and the camshaft journal holders; then place each camshaft into the correct position.

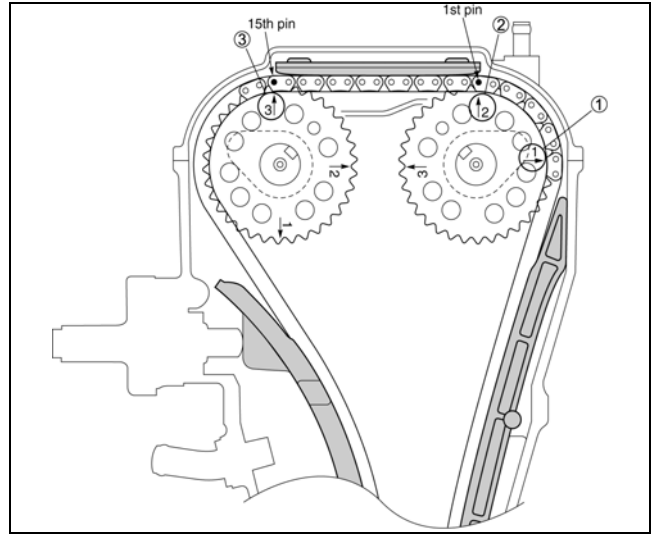

ATV2177

16. Install the alignment pins (1) and cam chain guide; then install the camshaft journal holder marked EX on the exhaust camshaft and the camshaft journal holder marked IN on the intake camshaft.

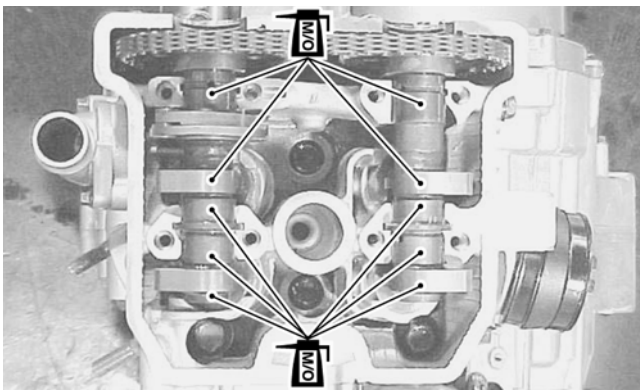

SP264

13. With the "T" line centered in the timing hole, hold the camshaft steady and pull up the cam chain to remove any slack; then turn the exhaust camshaft so the arrow (1) is aligned with the gasket surface of the cylinder head.
14. Engage the cam chain with the exhaust camshaft sprocket.
15. Starting at the roller pin directly above the arrow (2), count out 15 pins toward the intake camshaft; then align and engage the arrow (3) with the 15th pin.

■NOTE: The cam chain should now be on all three sprockets. Be careful not to rotate the crankshaft until the camshaft journals and cam chain tensioner are secured.

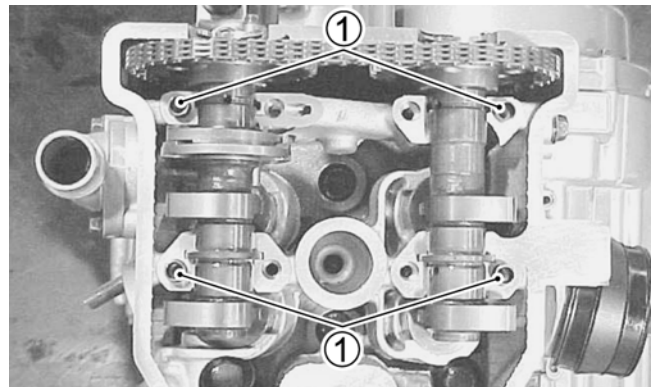

SP265

17. Making sure that the piston position is top-dead-center on the compression stroke, tighten the camshaft journal holder cap screws to specifications.

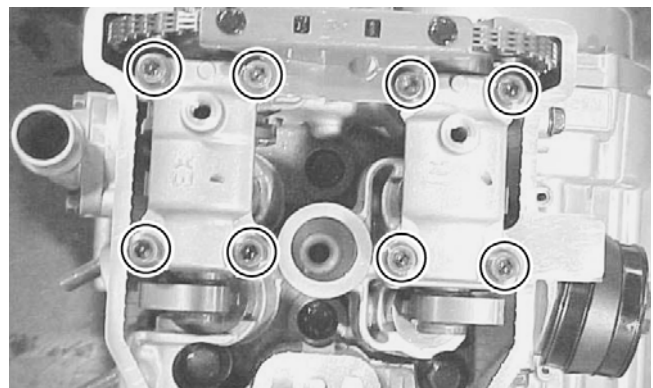

SP266

18. Apply engine oil to the tensioner push rod; then depress the ratchet mechanism (1) and depress the tensioner push rod (2) all the way into the tensioner housing.

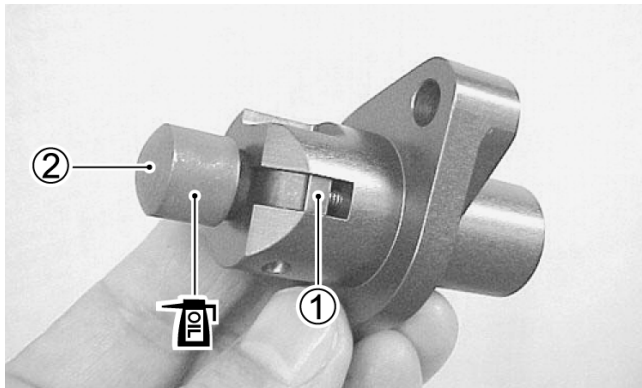

SP267

19. Install a new gasket and the cam chain tensioner assembly into the cylinder making sure the UP stamp is directed towards the cylinder head.
20. Tighten the cam chain tensioner Allen-head cap screws to specifications; then install the tensioner spring (3) and tighten the spring holder plug to specifications.

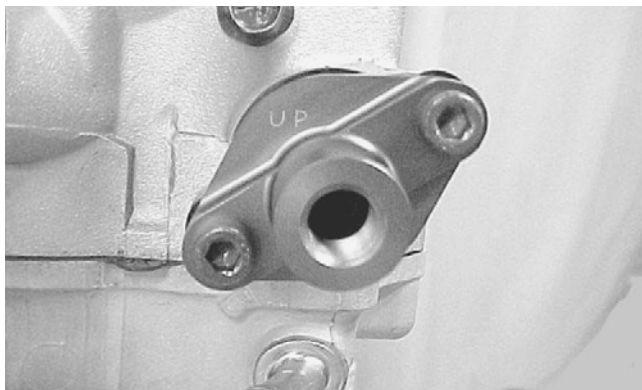

SP268



SP269

21. Adjust the valve clearance (see Section 2).
22. Wipe all oil from the mating surfaces of the valve cover and cylinder head; then apply Three Bond Sealant to the mating surfaces.
23. Apply engine oil to both sides of the washers (1); then lightly tighten the valve cover in two steps to specifications in a diagonal pattern.

■NOTE: Do not apply engine oil to rubber cushion (2).

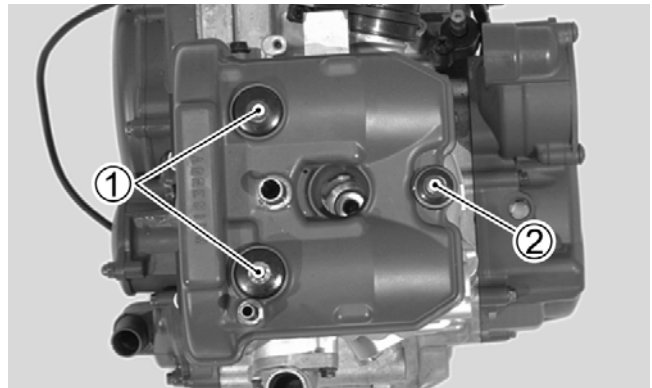

SP270

Installing Engine/Transmission

■NOTE: Critical torque specifications are located in Section 10.

3

■NOTE: Arctic Cat recommends that new gaskets and O-rings be installed whenever servicing the ATV.

1. From the left side, place the engine/transmission into the frame.
2. Install the mounting fasteners securing the engine/transmission in the following sequence.
 - A. Lower rear: One cap screw and nut with two spacers. Tighten only until snug.
 - B. Upper rear: Loosely fasten the engine mount-to-frame cap screws; then install the cap screw w/nut and flat washer. Tighten only until snug.
 - C. Lower front: One cap screw, nut, spacer, and washer. Tighten only until snug.
 - D. Upper front: Two cap screws (inside the bracket) and one cap screw and nut (topside of engine). Tighten only until snug.

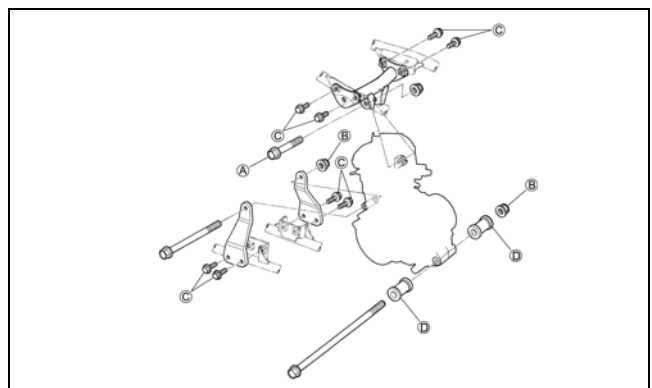

ATV2178

3. Tighten the engine mounting fasteners to the specifications.

A. Lower rear and lower front.

B. Upper front (inside the bracket) and upper front (topside of engine).

C. Upper engine mount-to-frame cap screws and engine to engine mount cap screw with nut and flat washer.

4. Install the exhaust pipe and muffler; then tighten the exhaust pipe nut (1), muffler mounting bolts (2), and the connector bolt (3) to specifications.

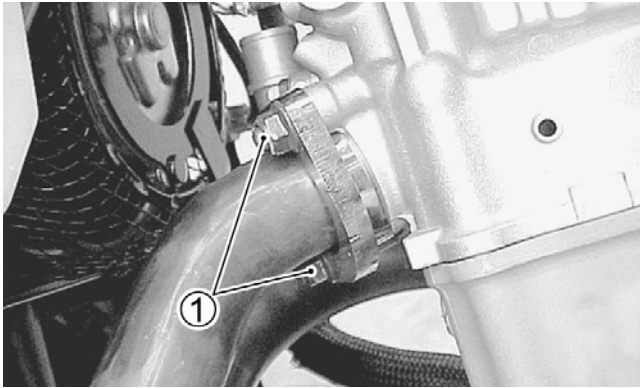

SP271

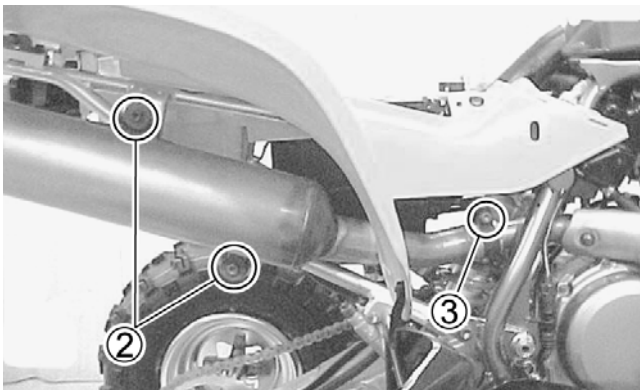

SP272

5. Install the engine drive sprocket with drive chain noting marking (A) on the sprocket; then apply red Loctite #271 to the threads and tighten the cap screws to specifications.

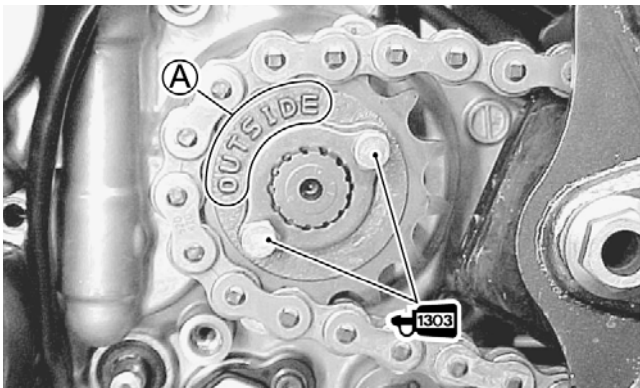

SP273

6. Install the engine coolant hose; then install the spacer (1) with O-ring to the engine oil outlet pipe and tighten the cap screws (2) securely.

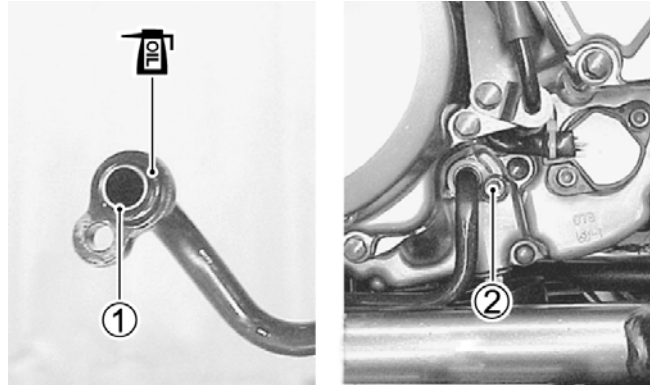

SP274A

7. Install the engine oil union bolt and tighten to specifications.

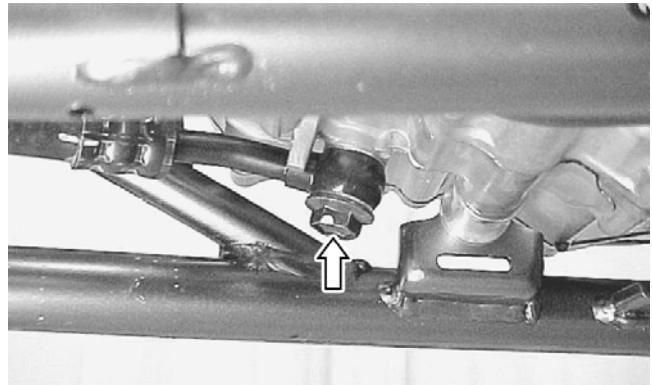

SP276

8. Join the wiring connectors to the alternator lead wire coupler (3) and the neutral start lead coupler (4); then connect the starter cables.

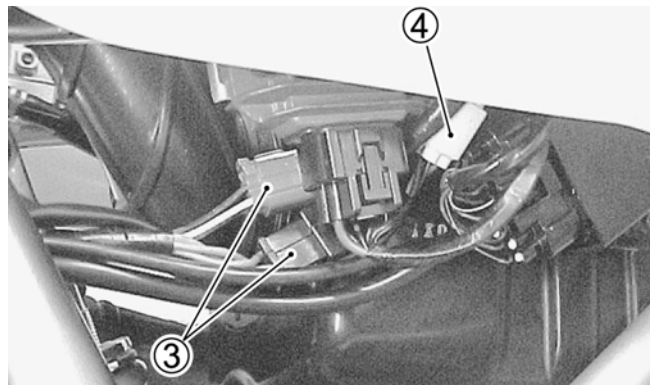

SP277

9. Connect the reverse gear selector cable (6); then install the cable bracket (5).

10. Install the clutch cable to the clutch actuator lever.

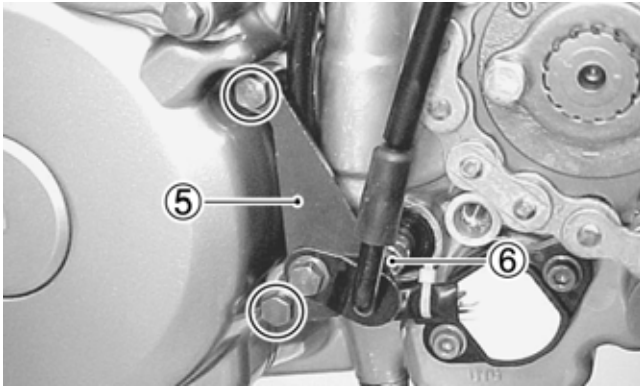

SP278

11. Install the carburetor and tighten the clamps securely.
12. Install the spark plug cap, engine sprocket cover, oil drain, tank, and breather hose; then install the gas tank and body.

13. Fill the oil tank (see Section 2).
14. Fill the cooling system with the appropriate mix of Arctic Cat anti-freeze and water (see Section 2).
15. Connect all remaining electrical connections; then install the battery making sure to connect the positive battery cable first and the negative cable last.
16. Install the seat making sure it locks into position.

⚠ CAUTION

If the engine had a major overhaul or if any major part was replaced, proper engine break-in procedures must be followed (see Section 1). If the proper engine break-in procedures are not followed, severe engine damage may result.

SECTION 4 - FUEL/LUBRICATION/COOLING

4

TABLE OF CONTENTS

Carburetor Specifications	4-2
Carburetor Schematic	4-2
Carburetor	4-2
Cleaning and Inspecting Carburetor.....	4-5
Throttle Cable Free-Play	4-6
Engine RPM (Idle).....	4-6
Gas Tank	4-6
Fuel Valve	4-7
Gas/Vent Hoses	4-7
Oil Flow Chart	4-7
Oil Filter/Oil Pump	4-7
Testing Oil Pump Pressure.....	4-8
Oil Tank	4-8
Liquid Cooling System	4-9
Radiator/Fan.....	4-10
Hoses/Thermostat.....	4-10
Water Pump	4-11
Engine Coolant Temperature Switch.....	4-14
Cooling Fan Thermo-Switch.....	4-14

Carburetor Specifications

ITEM	
Type	Mikuni BSR36
Main Jet	130
Pilot Jet	22.5
Pilot Screw (turns)	1 1/2
Needle Jet	P-OM
Jet Needle	5E26-1
Idle RPM	1400-1600
Starter Jet	60
Float Arm Height	13 mm (0.5 in.)
Throttle Cable Free-Play (at lever)	3-5 mm (1/8-1/5 in.)

Carburetor Schematic

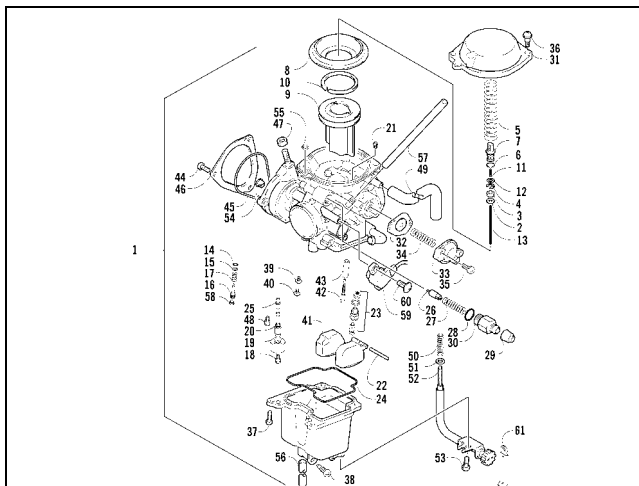

KEY

1. Carburetor Assembly	22. Pin	41. Float Assembly
2. Washer	23. Needle Valve Assembly	42. Pilot Jet
3. Ring	24. O-Ring	43. Pipe
4. E-Ring	25. Needle Jet	44. Screw
5. Spring	26. Plunger Assembly	45. O-Ring
6. O-Ring	27. Spring	46. Cover
7. Holder	28. O-Ring	47. Nut
8. Diaphragm	29. Cap	48. Starter Jet - 60
9. Piston Valve	30. Guide Holder	49. Hose
10. Ring	31. Diaphragm Cover	50. Spring
11. Spring	32. Diaphragm Assembly	51. Washer
12. Washer	33. Cover	52. Idle Adjustment Screw
13. Jet Needle	34. Spring	53. Screw
14. O-Ring	35. Screw	54. Cable Guide
15. Washer	36. Screw	55. O-Ring
16. Pilot Screw	37. Screw	56. Hose
17. Spring	38. Screw	57. Hose
18. Main Jet - 130	39. Screw	58. Plug
19. Ring	40. Screw	59. Sensor Assembly
20. Jet Holder		60. Screw
21. Jet		61. Clamp

www.mymowerparts.com

0740-390

Carburetor

⚠ WARNING

Whenever any maintenance or inspection is performed on the fuel system during which there may be fuel leakage, there should be no welding, smoking, open flames, etc., in the area.

■NOTE: The fuel valve is an automatic-off diaphragm style. Fuel will flow only when the engine is being started or when it is running; however, in the prime position, fuel will flow unrestricted to the carburetor.

REMOVING

1. Ensure the fuel valve is not in the PRI position.
2. Remove the seat.
3. Remove the air-intake snorkel.
4. Disconnect the hose from the carburetor to the gas tank at the fuel valve connection.
5. Loosen the flange clamps; then remove the carburetor from the two carburetor boots.
6. Remove the three screws securing the throttle actuator cover (5) to the carburetor; then remove the cover. Account for the O-ring (7).

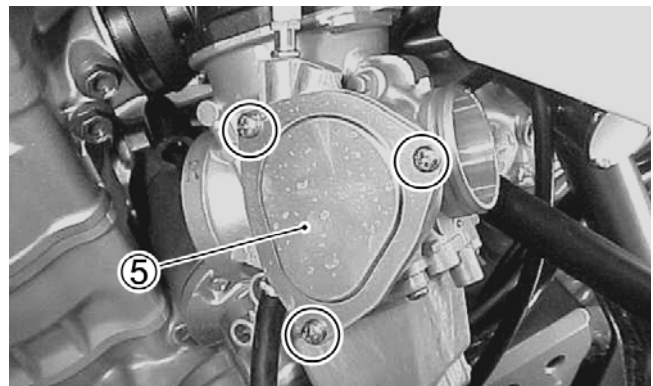

SP279

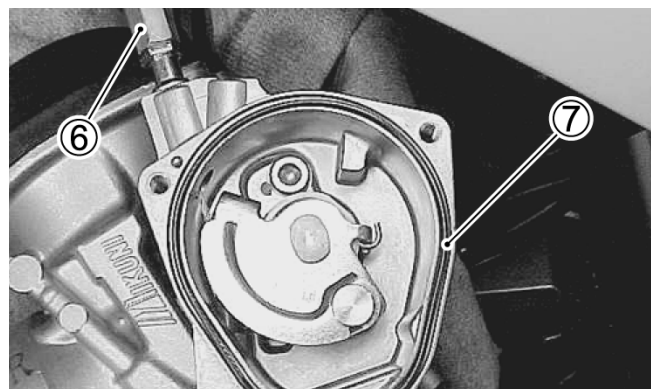

SP280

7. Disconnect the throttle cable from the actuator arm; then loosen the outer jam nut (6) securing the throttle cable to the carburetor body and route the cable out of the way.
8. By unscrewing the choke cable end (4), disconnect the choke cable from the carburetor.

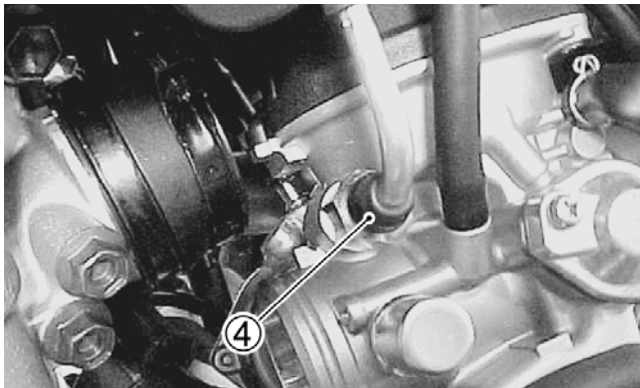

SP281

9. Disconnect the gas and vent hoses; then remove the carburetor.

DISASSEMBLING

1. Remove the two Phillips-head screws securing the diaphragm cover; then remove the cover, spring (1), O-ring (2), and the diaphragm (3).

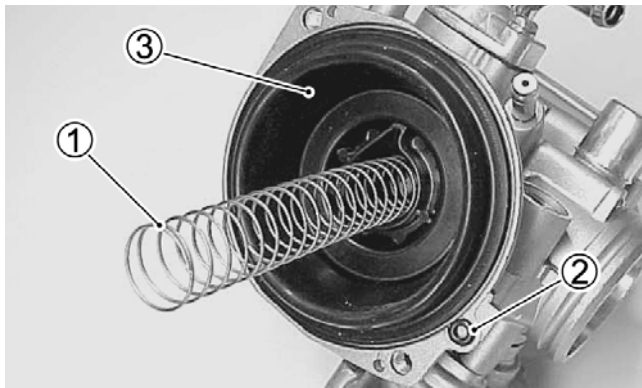

SP282

2. Remove the needle holder assembly from the diaphragm. Account for a spring, spring washer, and the jet needle.



SP283

3. Remove the two screws securing the primer housing cover. Account for the primer diaphragm assembly (11) and spring.

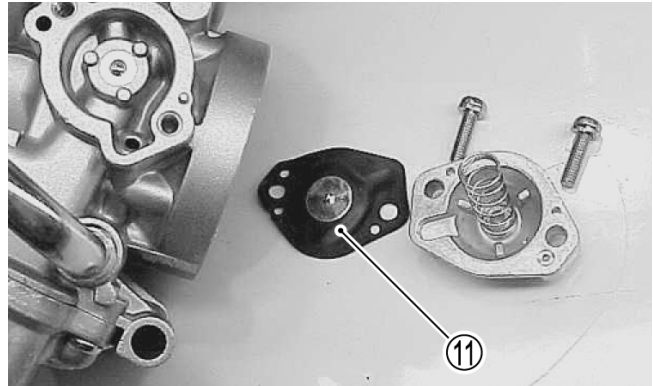

SP284

4. Remove the Phillips-head screws securing the float chamber; then remove the chamber. Account for the O-ring (12).



SP285

5. Remove the float pin (13); then lift the float assembly (14) from the carburetor. Account for the needle valve (15).

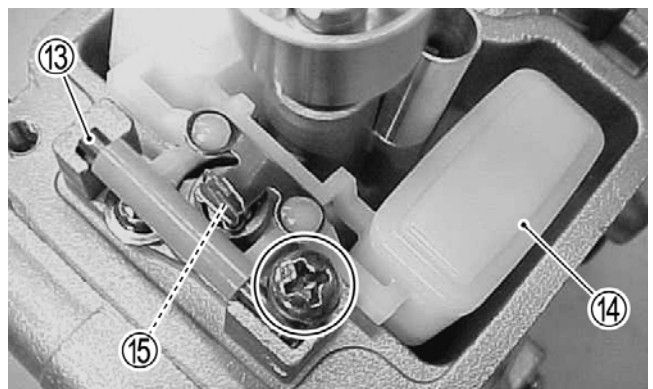

SP286

■ **NOTE:** Note the locations of the jets, pilot screw, and holder for disassembling procedures.

4

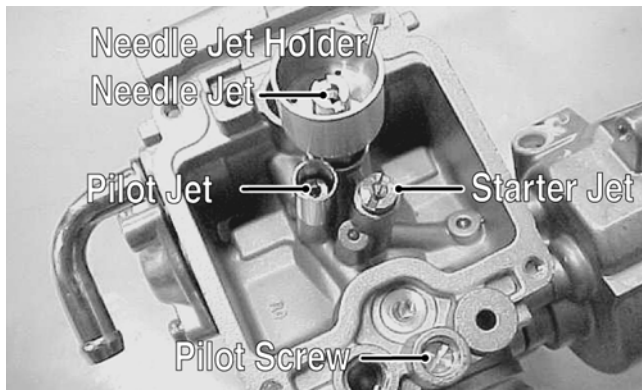

SP287A

6. Secure the needle jet holder with a wrench; then remove the main jet.
7. Remove the needle jet holder; then remove the pilot jet and the starter jet.
8. Remove and install the pilot air screw using the following procedure.
 - A. Using a 1/8-in. drill bit with a drill-stop (1) set at 4 mm (0.16 in.) from the end, drill through the plug (2).
 - B. Thread a self-tapping screw into the plug and use a pliers to pull the plug from the carburetor body (4).
 - C. Turn the pilot screw (3) clockwise counting the turns until it is lightly seated; then remove the pilot screw accounting for a spring, washer, and O-ring.

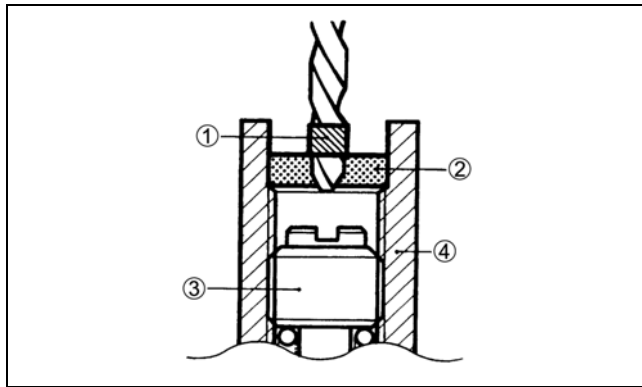

ATV2179

- D. After cleaning, install the pilot screw (with a new O-ring) to the original position by turning in until it lightly seats; then turning it out the number of turns counted in step C.
 - E. Using an appropriate punch, tap a new plug into place.
9. Unscrew and remove the idle adjustment screw. Account for the spring and washer.

AT THIS POINT
 Prior to assembling, the carburetor components should be cleaned and inspected (see Cleaning and Inspecting Carburetor sub-section).

ASSEMBLING

1. Screw the idle adjustment screw into the carburetor making sure the washer and spring are properly positioned.
2. Install the pilot jet (20). Tighten securely; then install the starter jet (19).
3. Install the main jet into the needle jet holder (17) and tighten securely; then install the needle jet holder assembly into the carburetor and tighten securely.

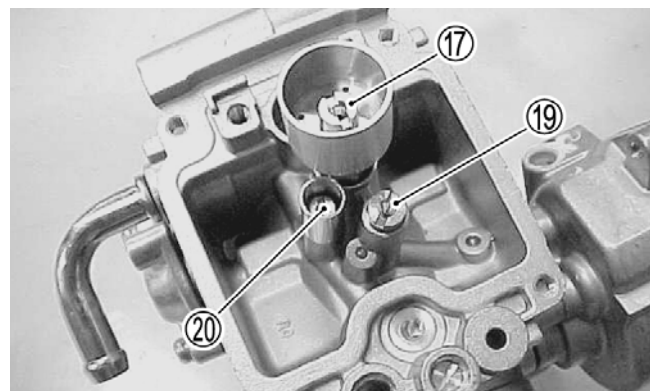

SP287B

4. Place the float assembly (with needle valve) into position and secure to the carburetor with the float pin.

NOTE: Check float arm height (A) by placing the carburetor on its side w/float contacting the needle; then measure with a caliper the height when the float arm is in contact with the needle valve. Float arm height should be 13 mm (0.5 in.).

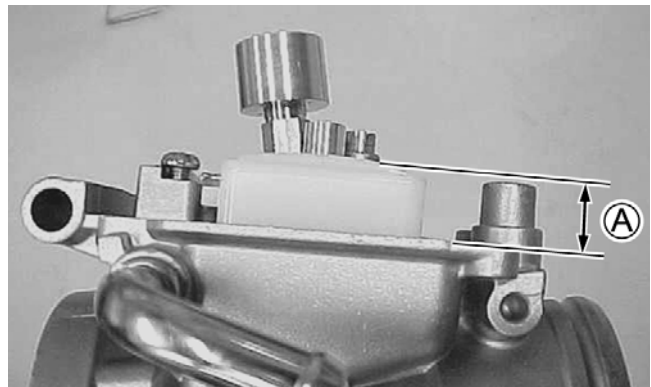

SP288

5. Place the float chamber into position making sure the O-ring is properly positioned; then secure with the Phillips-head screws.

- Position the spring and primer diaphragm assembly (lip toward the carburetor) onto the carburetor; then secure the assembly with the primer housing cover and two screws. Tighten securely.

⚠ CAUTION

It is important to press down on the primer housing until it contacts the carburetor to make sure the diaphragm lip is properly seated in the groove in the carburetor. If the diaphragm is not properly seated, leakage will occur.

- Place the jet needle, spring seat, and spring into the piston valve; then place the assembly down into the carburetor.

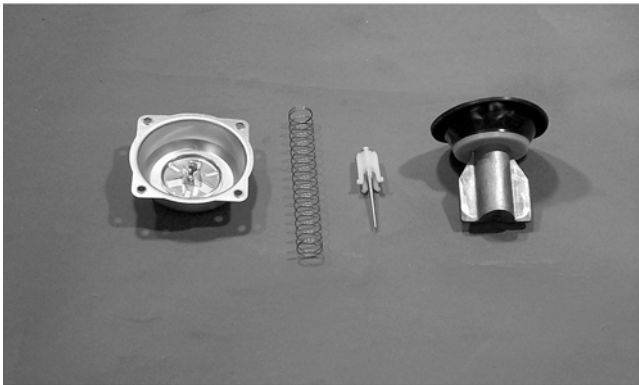

CC746

- Place the diaphragm cover into position; then secure with the Phillips-head screws. Tighten securely.

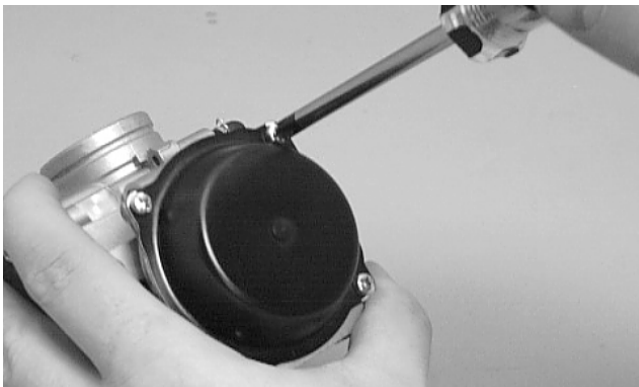

CH015D

INSTALLING

- Connect the gas and vent hoses onto the carburetor.
- Connect the choke cable by screwing the choke cable end onto the carburetor.
- Place the throttle cable into position and secure by tightening the outer jam nut.
- Connect the throttle cable to the actuator arm.

- Place the throttle actuator cover into position on the carburetor making sure the O-ring is properly positioned; then secure with three screws.
- Position the carburetor in the air cleaner and intake pipe boots; then secure with the clamps.
- Connect the hose at the fuel valve connection.
- Secure the air-intake snorkel.
- Install the seat and make sure it locks in position.

Cleaning and Inspecting Carburetor

NOTE: Whenever a part is worn excessively, cracked, or damaged in any way, replacement is necessary.

⚠ WARNING

When drying components with compressed air, always wear safety glasses.

⚠ CAUTION

DO NOT place any non-metallic components in parts-cleaning solvent because damage or deterioration will result.

- Place all metallic components in a wire basket and submerge in carburetor cleaner.
- Soak for 30 minutes; then rinse with fresh parts-cleaning solvent.
- Wash all non-metallic components with soap and water. Rinse thoroughly.
- Dry all components with compressed air only making sure all holes, orifices, and channels are unobstructed.
- Inspect the carburetor body for cracks, nicks, stripped threads, and any other imperfections in the casting.
- Inspect the piston valve/diaphragm for cracks, imperfections in the casting, or cracks and tears in the rubber.
- Inspect float for damage.
- Inspect gasket and O-rings for distortion, tears, or noticeable damage.
- Inspect tips of the jet needle, pilot screw, and the needle valve for wear, damage, or distortion.
- Inspect all jets for obstructions or damage.

NOTE: If the pilot jet is obstructed, the mixture will be extremely lean at idle and part-throttle operation.

11. Inspect the carburetor mounting flange for damage and tightness.

Throttle Cable Free-Play

To check/adjust throttle cable free-play, see Section 2.

Engine RPM (Idle)

To adjust idle RPM, see Section 2.

Gas Tank

WARNING

Whenever any maintenance or inspection is made on the fuel system during which there may be fuel leakage, there should be no welding, smoking, open flames, etc., in the area.

■NOTE: The fuel valve is an automatic-off diaphragm style. Fuel will flow only when the engine is being started or when it is running; however, in the prime position, fuel will flow unrestricted to the carburetor.

REMOVING

1. Ensure that the fuel valve is not in the PRI position.
2. Remove the seat; then remove the gas tank.
3. Remove the body from the frame (see Section 8).
4. Disconnect the hose (1) from the carburetor to the gas tank at the tank connection; then disconnect the vacuum hose (2).

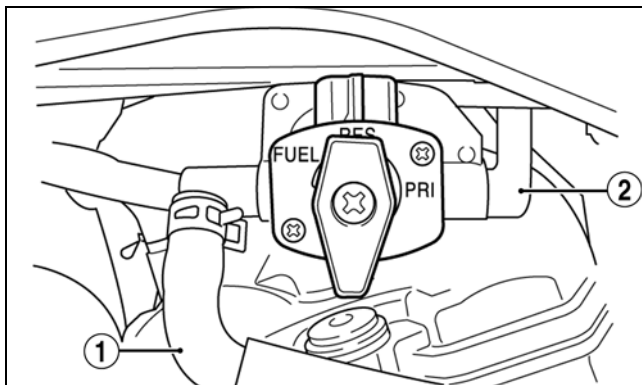

ATV2014A

5. Remove the cap screws securing the gas tank to the frame; then remove the air-intake snorkel (4).

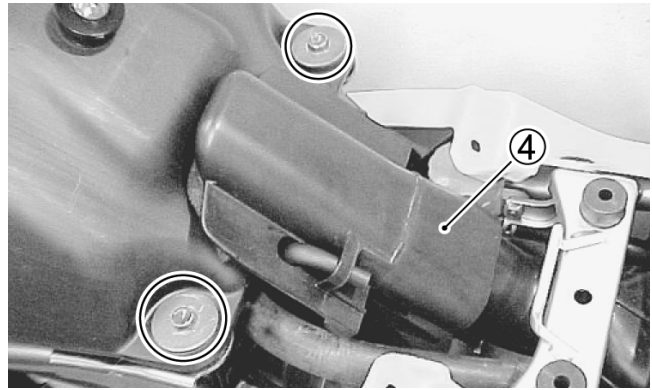

SP289

6. Remove the gas tank.

CLEANING AND INSPECTING

■NOTE: Whenever a part is worn excessively, cracked, or damaged in any way, replacement is necessary.

1. Clean all gas tank components with parts-cleaning solvent.
2. Inspect all hoses for cracks or leaks.
3. Inspect fuel valve, tank cap, and tank for leaks, holes, and damaged threads.

INSTALLING

1. Place the gas tank into position on the frame; then install the cap screws. Tighten securely; then install the snorkel.
2. Connect the hose from the carburetor; then secure hose to cables and hoses with a cable tie.
3. Connect the vacuum hose to the fuel valve.
4. Install the vent hose; then fill the gas tank with gasoline.
5. Turn the fuel valve to the PRI position and inspect for leakage. Turn the fuel valve to the ON position after checking for leaks.
6. Install the body and secure the mounting brackets to the frame; then install the seat and make sure it locks securely.

Fuel Valve

REMOVING/INSPECTING

⚠ WARNING

Drain the gas tank prior to this procedure.

1. Remove the hose from the fuel valve by releasing the spring clamp; then remove the vacuum hose.
2. Remove the two nuts securing the fuel valve; then remove the valve. Account for the gasket.
3. Inspect the gasket and fuel valve/tank mating surfaces for damage or deterioration.
4. Inspect for and remove any obstructions in the valve.

INSTALLING

1. Place the fuel valve and gasket into position on the tank and secure with the cap screws. Tighten to specifications (see Section 10).
2. Install the hose onto the fuel valve with the spring clamp; then connect the vacuum hose.

Gas/Vent Hoses

Replace the gas hose every two years. Damage from aging may not always be visible. Do not bend or obstruct the routing of the carburetor vent hose. Make certain that the vent hose is securely connected to the carburetor and the opposite end is always open.

Oil Flow Chart

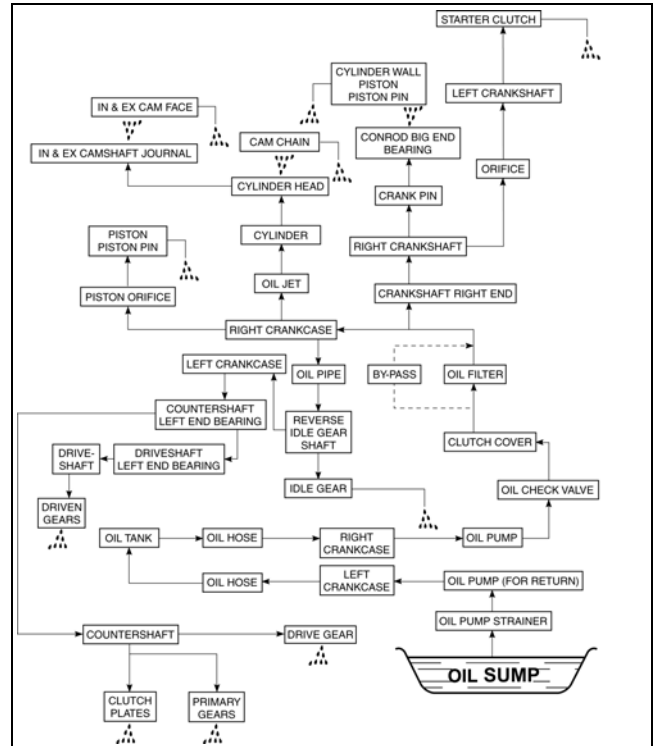

ATV2180

4

Oil Filter/Oil Pump

■NOTE: Whenever internal engine components wear excessively or break and whenever oil is contaminated, the oil pump should be disassembled, cleaned and inspected, and serviced as necessary.

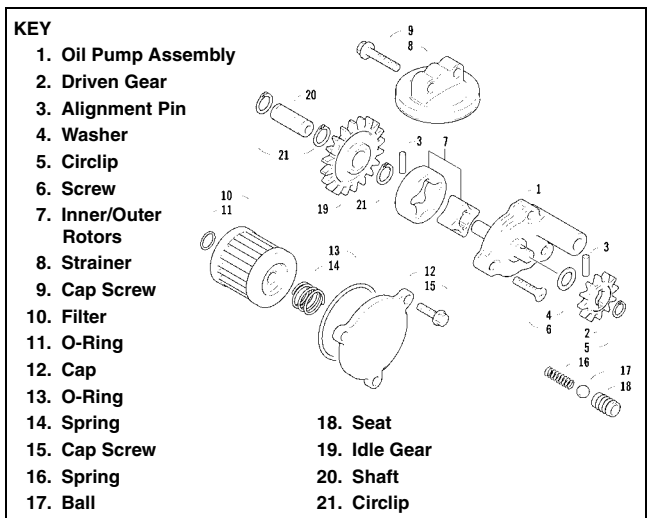

0739-215

REMOVING/DISASSEMBLING

1. Remove the oil pump from the engine (see Section 3 - Right-Side Components).
2. Disassemble oil pump components. Note the position of the inner and outer rotors and alignment pin for assembly.

CLEANING AND INSPECTING

■NOTE: Whenever a part is worn excessively, cracked, or damaged in any way, replacement is necessary.

1. Clean all oil-pump components.
2. Inspect the rotors for scoring and gouges.
3. Inspect the alignment pin for damage.
4. Inspect the pump housing for cracks or damage.

ASSEMBLING/INSTALLING

1. Place the rotors into the pump housing making sure the alignment pin is in the groove of the rotor.
2. Install the oil pump into the engine (see Section 3 - Right-Side Components).

Testing Oil Pump Pressure

■NOTE: The engine must be warmed up to operating temperature for this test.

1. Connect Tachometer (p/n 0644-275) to the engine.
2. Remove the oil galley plug; then connect the Oil Pressure Gauge (p/n 0444-039) to the galley using an appropriate adapter.

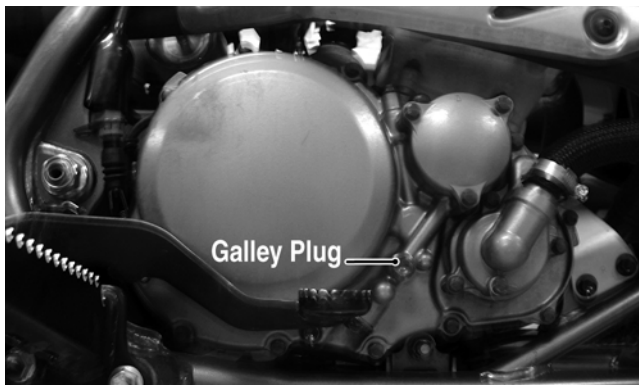

SP004A

■NOTE: Some oil seepage may occur when installing the oil pressure gauge. Wipe up oil residue with a cloth.

3. Start the engine and run at the specified RPM.
4. The oil pressure gauge must read 0.2 kg-cm² (2.8 psi) - 0.6 kg-cm² (8.5 psi).

■NOTE: If the oil pressure is lower than specified, check for an oil leak, damaged oil seal, or a defective oil pump.

■NOTE: If the oil pressure is higher than specified, check for too heavy engine oil weight (see Section 2), clogged oil passage, clogged oil filter, or improper installation of the oil filter.

Oil Tank

REMOVING

1. Remove the seat; then remove the fasteners securing the body to the frame and remove the body (see Section 8).
2. Drain the engine coolant; then remove the radiator (see Radiator/Fan in this section).
3. Drain the engine oil from the tank and remove the oil tank protector (1).

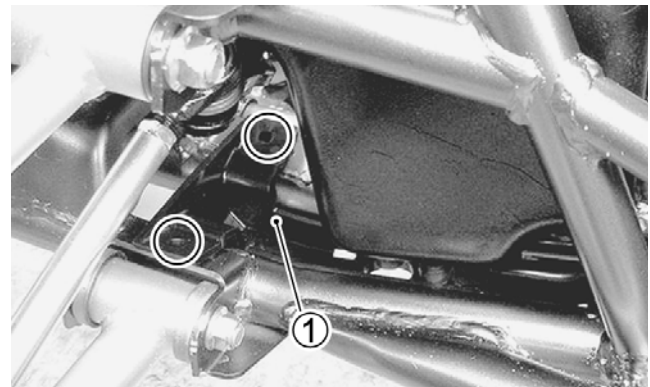

SP290

4. Remove the oil lines from the tank. Account for the two O-rings (7) and two alignment pins (8).

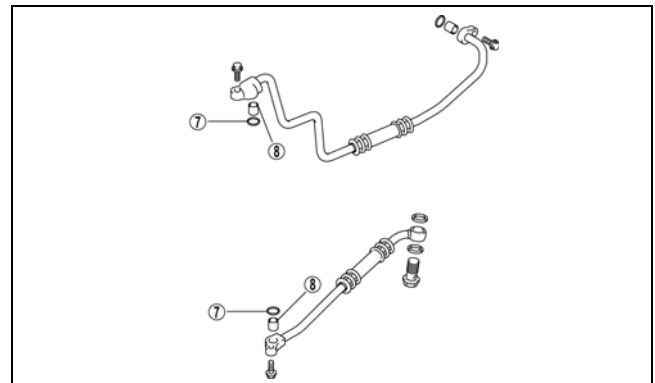

ATV2181A

- Remove the cap screws securing the tank to the frame; then remove the overflow hose and remove the tank. Account for the tank mounting isolators and two spacers.

■NOTE: If the tank isolators are oil soaked or damaged, new ones should be installed.

INSTALLING

- Ensure that the tank mounting isolators are serviceable; then install the tank onto the frame and tighten the cap screws securely.



SP291

- Install new O-rings to the upper and lower tank fittings; then secure the fittings to the tank and tighten the cap screws securely. Install the overflow hose.



SP292



SP293

- Fill the oil tank with the correct amount of recommended engine oil (see Section 2).

- Install the radiator (see Radiator/Fan in this section) and fill the cooling system.
- Install the body (see Section 8); then install the seat.
- Start the engine and check for coolant or oil leaks; then recheck the proper coolant and oil levels (see Section 2).

Liquid Cooling System

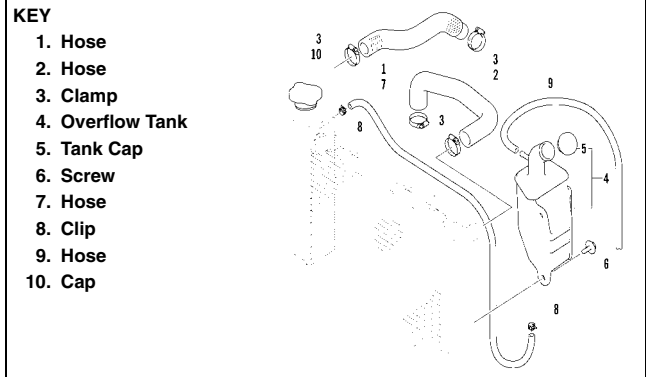

0739-224

4

When filling the cooling system, use premixed Arctic Cat Antifreeze. While the cooling system is being filled, air pockets may develop; therefore, run the engine for five minutes after the initial fill, shut the engine off, and then fill the cooling system to the bottom of the stand pipe in the radiator neck.



AN604D

CAUTION

After operating the ATV for the initial 5-10 minutes, stop the engine, allow the engine to cool down, and check the coolant level. Add coolant as necessary.

Radiator/Fan

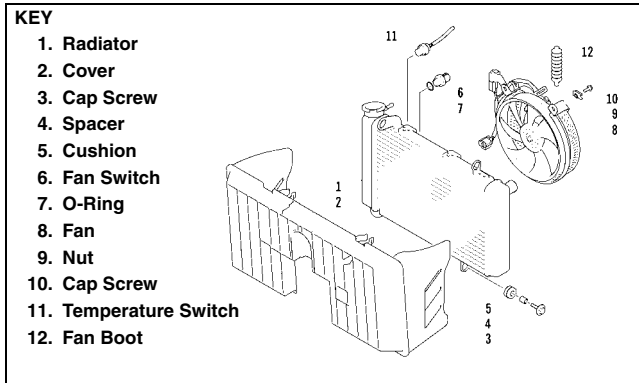

0739-218

REMOVING

1. Drain the coolant from the engine; then remove the seat and body (see Section 8).
2. Disconnect the negative battery cable; then disconnect the positive cable.
3. Remove the front bumper (see Section 8).
4. Remove the upper and lower coolant hoses.
5. Remove the cap screws and nuts securing the radiator to the frame.
6. Disconnect the fan wiring from the main wiring harness; then remove the radiator/fan assembly and account for the cushions and spacers.
7. Remove the fan assembly from the radiator.

CLEANING AND INSPECTING

■NOTE: Whenever a part is worn excessively, cracked, or damaged in any way, replacement is necessary.

1. Flush the radiator with water to remove any contaminants.
2. Inspect the radiator for leaks and damage.
3. Inspect all hoses for cracks and deterioration.
4. Inspect all fasteners and cushions for damage or wear.

INSTALLING

1. Position the fan assembly on the radiator; then secure with existing hardware.
2. Place the radiator with cushions and spacers into position on the frame; then install the cap screws and nuts. Tighten securely.

3. Install the upper and lower coolant hoses; then secure with hose clamps.
4. Install the front bumper (see Section 8).
5. Fill the cooling system with 1.2 L (1.3 U.S. qt) of antifreeze. Check for leakage.
6. Connect the fan wiring to the main wiring harness. Install the body and seat (see Section 8).

Hoses/Thermostat

REMOVING

1. Drain the coolant from the cooling system.
2. Remove the hose clamp securing the upper coolant hose to the thermostat housing; then remove the thermostat housing and the thermostat.

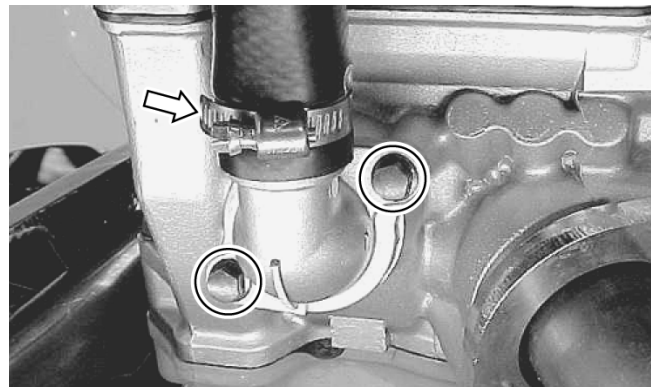

SP294

INSPECTING

■NOTE: Whenever a part is worn excessively, cracked, or damaged in any way, replacement is necessary.

1. Inspect the thermostat for corrosion, wear, or spring damage.
2. Using the following procedure, inspect the thermostat for proper operation.
 - A. Suspend the thermostat in a container filled with water.
 - B. Heat the water and monitor the temperature with a thermometer.
 - C. The thermostat should start to open at 75° C (167° F).
 - D. If the thermostat does not open, it must be replaced.
3. Inspect all coolant hoses, connections, and clamps for deterioration, cracks, and wear.

■NOTE: All coolant hoses and clamps should be replaced every four years.

INSTALLING

1. Place the thermostat into the thermostat housing; then secure the thermostat housing to the cylinder head with the two cap screws.
2. Slide the upper hose onto the thermostat housing; then secure with the hose clamp.
3. Fill the cooling system with 1.2 L (1.3 U.S. qt) of antifreeze. Check for leakage.



SP296

Water Pump

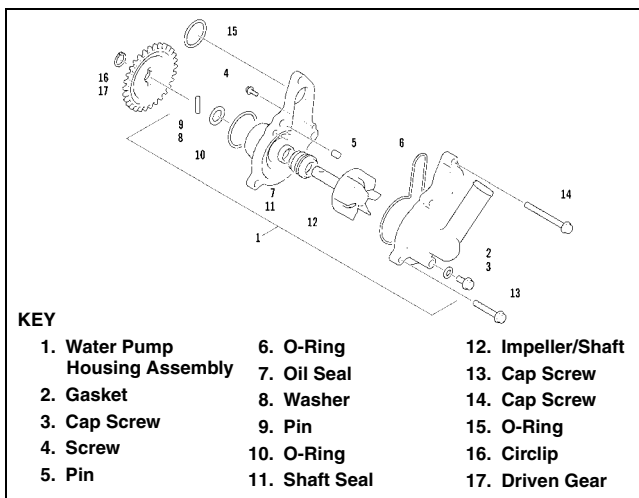

KEY

- | | | |
|--------------------------------|----------------|--------------------|
| 1. Water Pump Housing Assembly | 6. O-Ring | 12. Impeller/Shaft |
| 2. Gasket | 7. Oil Seal | 13. Cap Screw |
| 3. Cap Screw | 8. Washer | 14. Cap Screw |
| 4. Screw | 9. Pin | 15. O-Ring |
| 5. Pin | 10. O-Ring | 16. Circlip |
| | 11. Shaft Seal | 17. Driven Gear |

0740-401

REMOVING

1. Drain the engine coolant and engine oil; then disconnect the radiator hose.

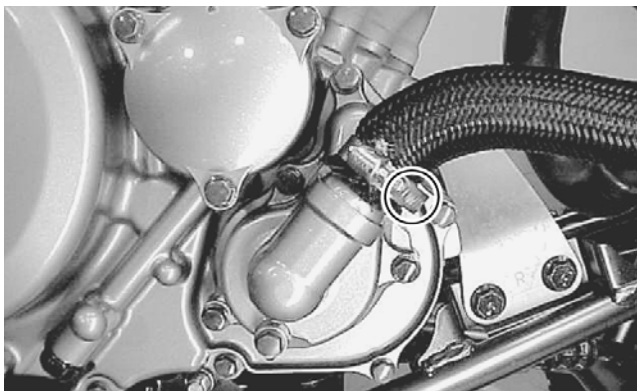

SP295

2. Disconnect the rear brake switch spring and brake pedal spring; then remove the master cylinder mounting bolts.



SP297

3. Remove the cap screws securing the clutch cover; then depress the brake pedal and remove the clutch cover.

4

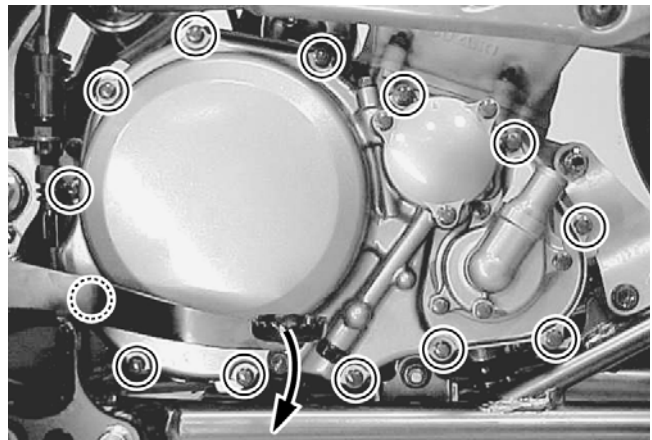

SP298

4. Remove the water pump case; then remove the circlip (1), water pump driven gear (2), drive pin (3), and washer (4).

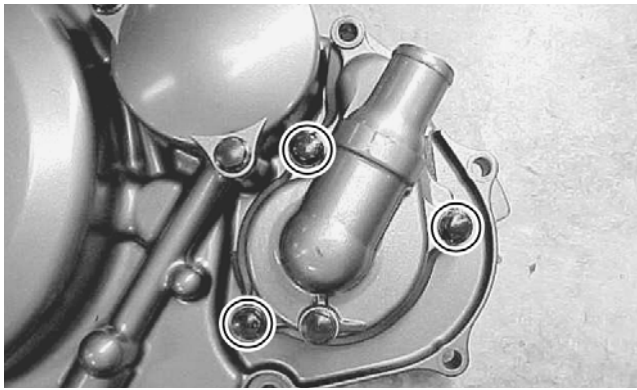

SP299

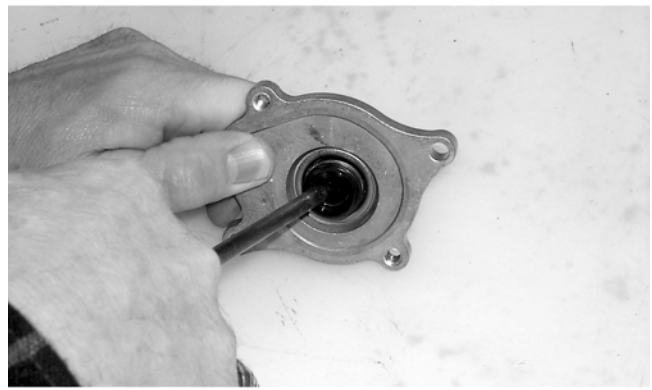

CC772

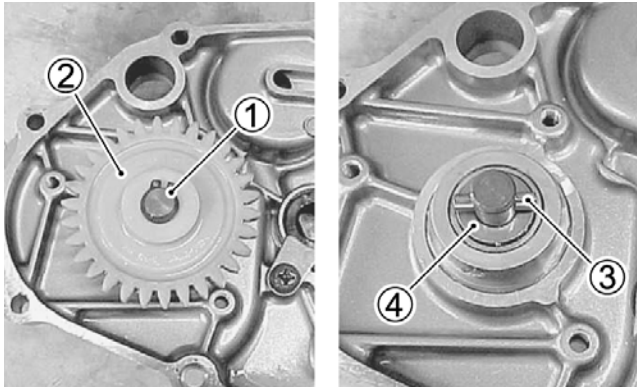

SP300A

DISASSEMBLING

1. Remove the impeller/shaft (5); then remove the pump housing (6).

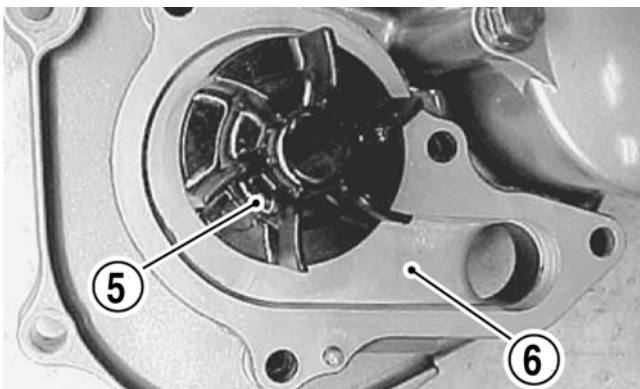

SP302B

2. Using Seal Removal Tool (p/n 0644-072), remove the shaft seal and the oil seal.

CLEANING AND INSPECTING

■NOTE: Whenever a part is worn excessively, cracked, or damaged in any way, replacement is necessary.

1. Clean all oil-pump components in cleaning solvent.
2. Inspect the impeller/shaft for corrosion or damage.

ASSEMBLING

1. Place the new oil seal into the housing; then using a seal driver, gently tap the seal down until it is fully seated.



SP304

2. Place the new shaft seal into the housing; then tap it down until it is fully seated.

■NOTE: A large, deep socket can be used to drive the seal down evenly.

3. Install new O-rings in the water pump housing; then install the water pump with impeller into the clutch cover.

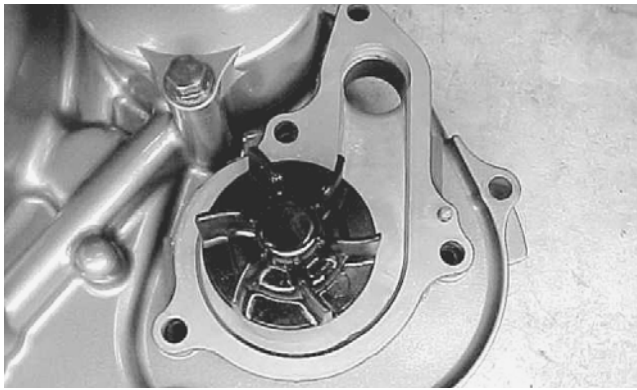

SP305

4. Install the washer (1), drive pin (2), and driven gear (3); then install the circlip (4). Make sure the circlip is properly seated.

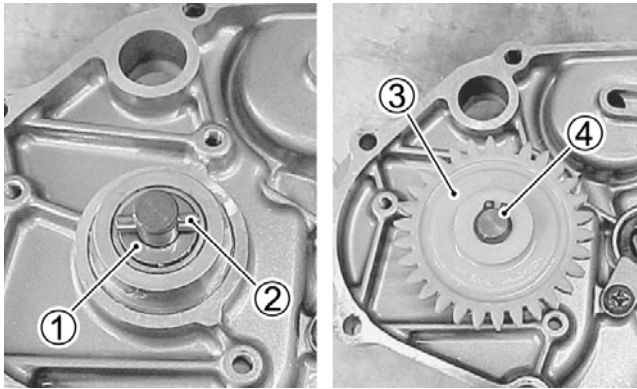

SP307A

INSTALLING

1. Install a new O-ring in the water pump case; then attach the case to the clutch cover.

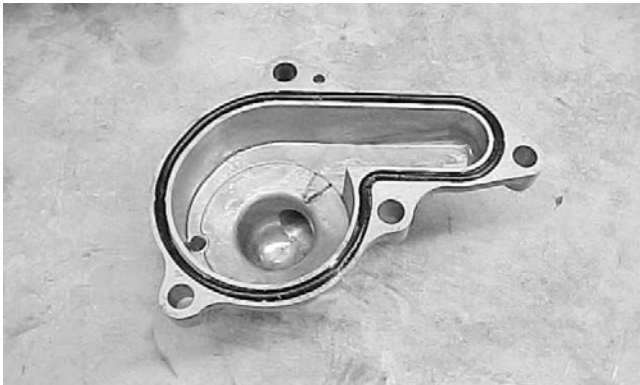

SP309

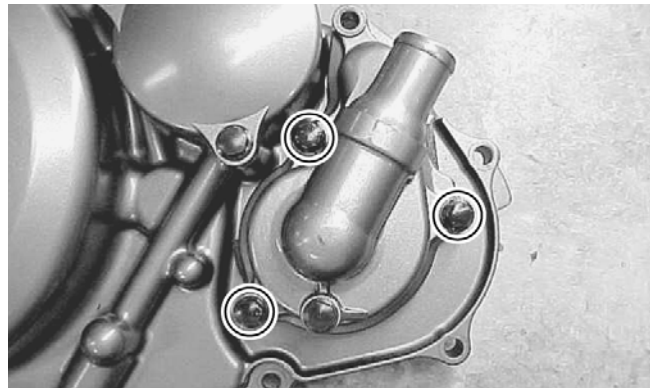

SP310

2. Install the clutch cover and tighten the cap screws securely; then install the master cylinder mounting bolts and tighten to specifications (see Section 10).
3. Connect the brake switch spring and the brake pedal spring.
4. Connect the radiator hose; then fill the cooling system with the recommended amount of coolant.



AN604D

4

■ **NOTE:** While the cooling system is being filled, air pockets may develop; therefore, run the engine for five minutes after the initial fill, shut the engine off, and then fill the cooling system.

5. Refill the engine oil tank; then run the engine for several minutes and check for leaks. Recheck the engine oil and coolant levels.
6. Check the entire cooling system for leakage.

⚠ CAUTION

After operating the ATV for the initial 5-10 minutes, stop the engine, allow the engine to cool down, and check the coolant level. Add coolant as necessary.

Engine Coolant Temperature Switch

REMOVING

1. Drain the coolant in the radiator to a point below the upper temperature switch.
2. Disconnect the engine coolant temperature lead wire coupler (1); then remove the engine coolant temperature switch (2).



SP311

■NOTE: For complete testing procedures for the switch, see Section 5.

INSTALLING

1. Apply engine coolant to the O-ring; then install the engine coolant temperature switch and tighten to specifications (see Section 10).
2. Connect the lead wire coupler; then fill the cooling system with recommended coolant.
3. Start the engine and check for coolant leaks; then shut the engine off and check coolant level in the overflow tank. Coolant should be between upper and lower level marks.

Cooling Fan Thermo-Switch

REMOVING

1. Drain the coolant in the radiator to a point below the lower temperature switch.
2. Disconnect the cooling fan thermo-switch lead wire coupler (1); then remove the cooling fan thermo-switch (2).

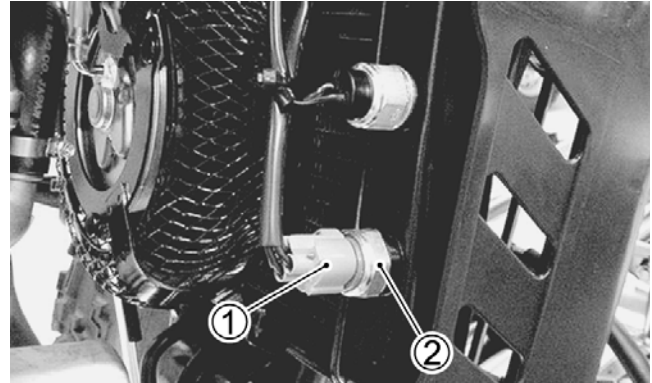

SP312

■NOTE: For complete testing procedures for the thermo-switch, see Section 5.

Installing

1. Apply engine coolant to the O-ring; then install the cooling fan thermo-switch and tighten to specifications (see Section 10).
2. Connect the lead wire coupler; then fill the cooling system with recommended coolant.
3. Start the engine and check for coolant leaks; then shut the engine off and check coolant level in the overflow tank. Coolant should be between upper and lower level marks.

SECTION 5 - ELECTRICAL SYSTEM

TABLE OF CONTENTS

Specifications	5-2
Battery	5-2
Testing Electrical Components	5-2
Brakelight Switch	5-2
Coolant Temperature and Cooling Fan Switches	5-3
Fan Motor	5-3
Fuse Holder	5-3
Fuse	5-4
Ignition Coil	5-4
Indicator Lights	5-5
Ignition Switch	5-6
Handlebar Control Switches	5-6
Neutral Switch	5-7
Clutch Lever Position Switch	5-7
Magneto Coils	5-7
Starter Motor	5-8
Starter Relay	5-11
CDI Unit	5-11
Regulator/Rectifier	5-11
Headlights	5-11
Taillight - Brakelight	5-12
Throttle Position Sensor (TPS)	5-12
Ignition Timing	5-13

Specifications

IGNITION	
Ignition Timing	10° BTDC @ 1500 RPM
Spark Plug Type	NGK CR7E
Spark Plug Gap	0.7-0.8 mm (0.028-0.032 in.)
Spark Plug Cap	12,000-20,000 ohms
Ignition Coil Resistance (primary)	0.1-1.0 ohm (terminal to ground)
(secondary)	6,000-7,000 ohms (high tension - plug cap removed - to ground)
Ignition Coil Peak Voltage (primary/CDI)	130+ DC volts (red test lead to black/white) (black test lead to black)
Engine Coolant Fan Thermo-Switch Operating Temperature	(off→on) 88°C (190°F) (on→off) 82°C (180°F)
MAGNETO	
Magneto Coil Resistance (trigger)	350-670 ohms (green to blue)
(charging)	0.1-1.5 ohms (brown to brown)
Magneto Coil Peak Voltage (trigger)	2.0+ DC volts (green to blue)
(charging)	14-15.5 DC volts (black test lead to (-) battery) (red test lead to (+) battery)

Battery

For battery related information, see Section 2.

Testing Electrical Components

All of the electrical tests should be made using the Fluke Model 73 Multimeter (p/n 0644-191) and when testing peak voltage, the Peak Voltage Reading Adapter (p/n 0644-307) must be used. If any other type of meter is used, readings may vary due to internal circuitry. When troubleshooting a specific component, always verify first that the fuse is good, that the bulbs are good, that the connections are clean and tight, that the battery is fully charged, and that all appropriate switches are activated.

NOTE: For absolute accuracy, all tests should be made at room temperature of 68° F.

Brakelight Switch

FRONT BRAKE

NOTE: For ease of access to the electrical connectors, removing the seat and body is recommended (see Section 8).

The switch connector is the two-prong one located in front of the steering post.

Resistance (Switch Connector)

⚠ CAUTION

Always disconnect the battery when performing resistance tests to avoid damaging the multimeter.

1. Set the meter selector to the OHMS position.
2. Connect the red tester lead to the orange wire; then connect the black tester lead to the black/white wire.
3. When the brake lever is compressed, the meter must show less than 1 ohm.

NOTE: If the meter shows more than 1 ohm of resistance, troubleshoot or replace the switch/component, the connector, or the switch wiring harness.

REAR BRAKE

The switch connector is the two-prong connector located along the upper right frame rail.

Resistance (Switch Connector)

⚠ CAUTION

Always disconnect the battery when performing resistance tests to avoid damaging the multimeter.

NOTE: The brake pedal must be depressed for this test. Also, the ignition switch must be in the OFF position.

1. Set the meter selector to the OHMS position.
2. Connect the red tester lead to the orange wire; then connect the black tester lead to the black/white wire.
3. When the pedal is depressed, the meter must show less than 1 ohm.

NOTE: If the meter shows more than 1 ohm of resistance, troubleshoot or replace the switch/component, the connector, or the switch wiring harness.

Coolant Temperature and Cooling Fan Switches

1. Connect the meter leads (selector in the OHMS position) to the switch contacts.
2. Suspend the switch and a thermometer in a container of oil; then heat the oil.

■NOTE: Neither the switch nor the thermometer should be allowed to touch the bottom of the container or inaccurate readings will occur. Use wire holders to suspend switch and thermometer.

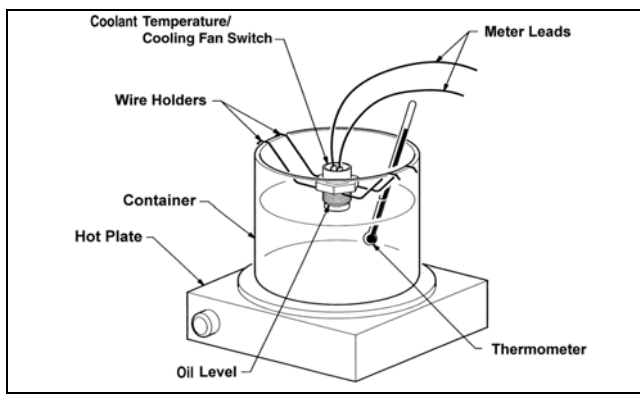

733-554E

3. On the coolant temperature switch when the oil temperature reaches 120° C (248° F), the meter should read a closed circuit.
4. On the coolant temperature switch, allow the oil to cool, and when the temperature is at (or just before) a temperature of 113° C (235° F), the meter should read an open circuit.
5. On the cooling fan switch when the temperature reaches 88° C (190° F), the meter should read a closed circuit.
6. On the cooling fan switch, allow the oil to cool and when the temperature is at (or just before) a temperature of 82° C (180° F), the meter should read an open circuit.
7. If the readings are not as indicated, the switch must be replaced.
8. Install the switch and tighten securely.
9. Connect the switch leads.

Fan Motor

■NOTE: The ignition switch must be in the ON position.

VOLTAGE (Main Harness Connector to Fan Motor)

1. Set the meter selector to the DC Voltage position.
2. Connect the red tester lead to the orange wire (the black 2-prong at the fan motor); then connect the black tester lead to ground.
3. The meter must show battery voltage.

■NOTE: If the meter shows no battery voltage, troubleshoot the battery, fuse, motor, or the main wiring harness.

■NOTE: If the meter shows battery voltage, the main wiring harness is good. The connector should be tested for resistance.

■NOTE: To determine if the fan motor is good, connect the red wire from the fan connector to a 12 volt DC power supply; then connect the black/red wire from the fan connector to ground. The fan should operate.

5

⚠ WARNING

Care should be taken to keep clear of the fan blades.

Fuse Holder

The fuse and a spare are located on the starter relay under the seat.

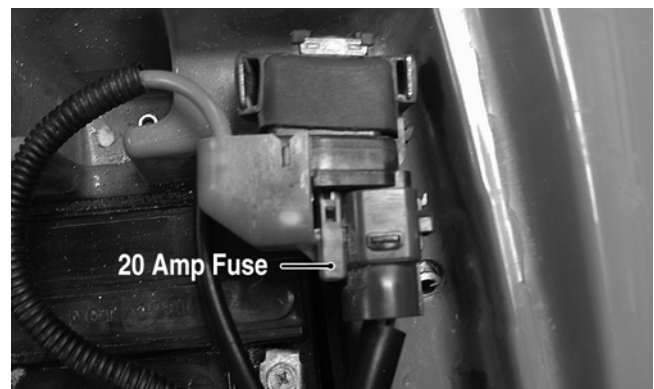

SP032A

1. Remove the fuse from the starter relay.
2. Set the meter selector to the DC Voltage position.

3. Connect the black tester lead to ground.
4. Using the red tester lead, contact the battery side of the fuse holder connector terminal.
5. The meter must show battery voltage.

■NOTE: Battery voltage will be indicated from only one side of the fuse holder connector terminal; the other side will show an open circuit.

■NOTE: If the meter shows no battery voltage, troubleshoot the battery, switches, fuse holder, or the main wiring harness.

Fuse

⚠ CAUTION

Always disconnect the battery when performing resistance tests to avoid damaging the multimeter.

1. Set the meter selector to the OHMS position.
2. Connect the red tester lead to one spade end of the fuse; then connect the black tester lead to the other spade end.
3. The meter must show less than 1 ohm resistance. If the meter reads open, replace the fuse.

Ignition Coil

The ignition coil is attached to the upper frame near the top of the radiator. To access the coil, the seat, body, and gas tank must be removed (see Section 8).

PEAK VOLTAGE (Primary Side)

■NOTE: Peak voltage test should be made using the Fluke Model 73 Multimeter (p/n 0644-191) with Peak Voltage Reading Adapter (p/n 0644-307). If any other type of tester is used, reading may vary due to internal circuitry.

■NOTE: The battery must be at full charge for this test.

■NOTE: The ignition switch must be in the ON position; the emergency stop switch must be in the RUN position.

1. Remove the spark plug cap; then connect a new spark plug to the spark plug cap and ground it to the cylinder head.

2. Using the multimeter with the peak voltage adapter, connect the red tester lead (+) to the black/white lead wire (or to ground) and the black tester lead (-) to the black wire.

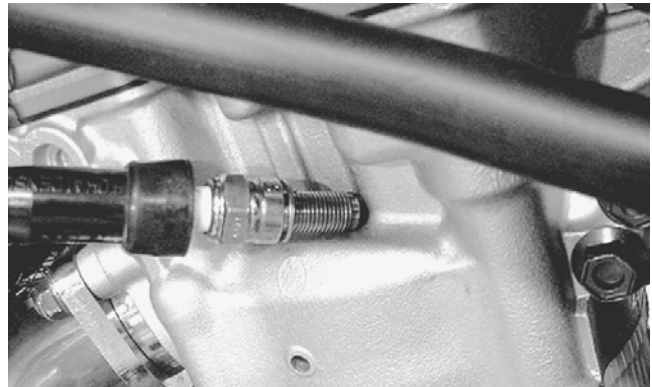

SP313

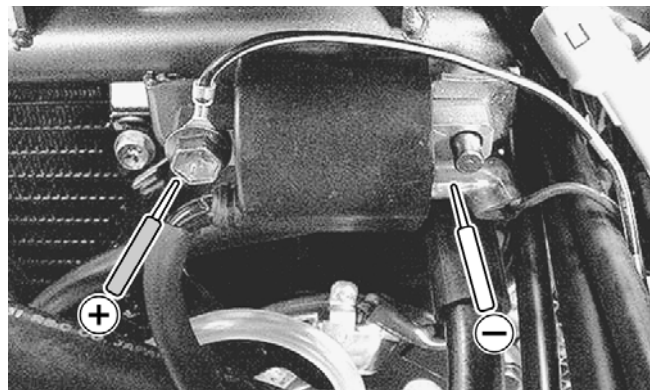

SP314

3. Set the meter selector to the DC Voltage position.
4. With the tester leads connected, compress the clutch lever and depress the starter button.
5. The meter reading must be within specification.

■NOTE: If the voltage is not as specified, inspect the main wiring harness, connectors, source/charge coil, magneto rotor and magnets, magneto rotor key, or the CDI unit.

RESISTANCE

⚠ CAUTION

Always disconnect the battery when performing resistance tests to avoid damaging the multimeter.

■NOTE: For these tests, the meter selector should be set to the OHMS position.

Primary Winding

1. Connect the red tester lead to the terminal (with the wire removed); then connect the black tester lead to ground.
2. The meter reading must be within specification.

Secondary Winding

1. Connect the red tester lead to the high tension lead (plug cap removed); then connect the black tester lead to ground.
2. The meter reading must be within specification.

■NOTE: If the meter does not show as specified, replace ignition coil.

Spark Plug Cap

1. Connect the red tester lead to one end of the cap; then connect the black tester lead to the other end of the cap.

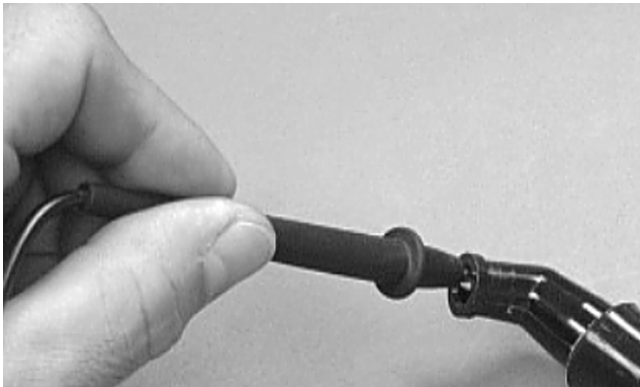

AR603D

2. The meter reading must be within specification.

■NOTE: If the meter does not show as specified, replace the spark plug cap.

Indicator Lights

The indicator lights connector being tested is the four-wire one in front of the steering post.

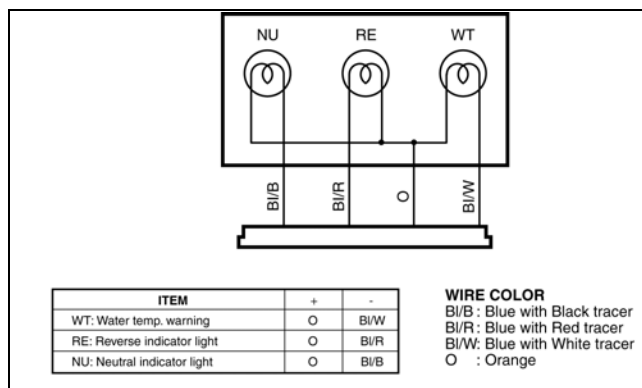

ATV2183

To access the indicator light connector for testing purposes, use the following procedure.

1. Remove the seat and body (see Section 8).

2. Disconnect the four-wire connector from the main wiring harness.

■NOTE: For these tests, a 12-volt power supply “jumper” should be used to supply power.

WATER TEMPERATURE INDICATOR LIGHT

1. Connect the jumper positive wire to the power source terminal on the indicator light connector.
2. Connect the jumper ground wire to the blue/white (temperature) wire on the indicator light connector.
3. The water temperature indicator light should illuminate.

NEUTRAL INDICATOR LIGHT

1. Connect the jumper positive wire to the power source terminal on the indicator light connector.
2. Connect the jumper ground wire to the blue/black (neutral) wire on the indicator light connector.
3. The neutral indicator light should illuminate.

REVERSE INDICATOR LIGHT

1. Connect the jumper positive wire to the power source terminal on the indicator light connector.
2. Connect the jumper ground wire to the blue/red (reverse) wire on the indicator light connector.
3. The reverse indicator light should illuminate.

■NOTE: If a light fails to illuminate in any one of the indicator light tests, the connector, wiring harness, or a bulb must be replaced.

INDICATOR LIGHTS VOLTAGE

■NOTE: The ignition switch must be in the ON position, and the test must be performed on the lower side of the connector.

1. Set the meter selector to the DC Voltage position.
2. Connect the red tester lead to the orange wire; then connect the black tester lead to ground.
3. The meter must show battery voltage.

■NOTE: This is the only voltage test for all indicator lights.

After testing procedures are completed, use the following procedure.

1. Connect the indicator light four-wire connector to the main harness.
2. Install the body and seat (see Section 8).

Ignition Switch

The connector is the three-wire one in front of the steering post. To access the connector, the body and seat must be removed (see Section 8).

VOLTAGE

■NOTE: Perform this test on the lower side of the connector.

1. Set the meter selector to the DC Voltage position.
2. Connect the red meter lead to the red wire; then connect the black meter lead to ground.
3. Meter must show battery voltage.

■NOTE: If the meter shows no battery voltage, troubleshoot the battery or the main wiring harness.

RESISTANCE

⚠ CAUTION

Always disconnect the battery when performing resistance tests to avoid damaging the multimeter.

■NOTE: Perform this test on the upper side of the connector.

1. Turn the ignition switch to the ON position.
2. Set the meter selector to the OHMS position.
3. Connect the red tester lead to the red wire; then connect the black tester lead to the orange wire.
4. The meter must show less than 1 ohm.
5. Turn the ignition switch to the LIGHTS position.
6. Connect the red tester lead to the red wire; then connect the black tester lead to the orange wire.
7. The meter must show less than 1 ohm.
8. Connect the red tester lead to the red wire; then connect the black tester lead to the gray wire.
9. The meter must show less than 1 ohm.
10. With the switch in the OFF position, connect the red tester lead to the red wire and the black tester lead to each of the remaining wires (orange and gray). The meter must show an open circuit on both wires.

■NOTE: If the meter shows more than 1 ohm of resistance, troubleshoot or replace the switch/component, the connector, or the switch wiring harness.

Handlebar Control Switches

The connector is the yellow one in front of the steering post. To access the connector, the body and seat must be removed (see Section 8).

■NOTE: These tests should be made on the top side of the connector.

⚠ CAUTION

Always disconnect the battery when performing resistance tests to avoid damaging the multimeter.

RESISTANCE (HI Beam)

1. Set the meter selector to the OHMS position.
2. Connect the red tester lead to the yellow wire; then connect the black tester lead to the gray wire.
3. With the dimmer switch in the HI position, the meter must show less than 1 ohm.

■NOTE: If the meter shows more than 1 ohm of resistance, troubleshoot or replace the switch/component, the connector, or the switch wiring harness.

RESISTANCE (LO Beam)

1. Set the meter selector to the OHMS position.
2. Connect the red tester lead to the white wire; then connect the black tester lead to the gray wire.
3. With the dimmer switch in the LO position, the meter must show an open circuit.

■NOTE: If the meter reads resistance, troubleshoot or replace the switch/component, the connector, or the switch wiring harness.

RESISTANCE (Starter Button)

1. Set the meter selector to the OHMS position.
2. Connect the red tester lead to the orange/white wire; then connect the black tester lead to the black wire.
3. With the starter button depressed, the meter must show less than 1 ohm.
4. With the starter button released, the meter must show an open circuit.

■NOTE: If the meter does not show as specified, replace the switch/component, connector, or switch harness.

RESISTANCE (Emergency Stop)

1. Set the meter selector to the OHMS position.
2. Connect the red tester lead to the orange wire; then connect the black tester lead to the orange/white wire.
3. With the switch in the OFF position, the meter must show an open circuit.
4. With the switch in the RUN position, the meter must show less than 1 ohm.

■NOTE: If the meter shows more than 1 ohm of resistance, troubleshoot or replace the switch/component, the connector, or the switch wiring harness.

Neutral Switch

RESISTANCE

⚠ **CAUTION**

Always disconnect the battery when performing resistance tests to avoid damaging the multimeter.

1. Disconnect the battery; then disconnect the white four-wire connector located to the rear of the regulator/rectifier.



SP081A

2. Set the meter selector to the OHMS position; then connect the black meter lead to the black wire and the red meter lead to the blue wire.
3. With the transmission in neutral, the meter should show less than 1 ohm.
4. Depress the gear shifter pedal to engage first gear. The meter should show an open circuit.
5. Connect the red meter lead to the white wire. The meter should show less than 1 ohm.

6. Rotate the reverse selector knob clockwise and depress the gear shifter pedal to engage reverse gear; then connect the red meter lead to the red wire. The meter must show less than 1 ohm.
7. Lift the gear shifter pedal twice to return to neutral. The meter must show an open circuit.

Clutch Lever Position Switch

RESISTANCE

⚠ **CAUTION**

Always disconnect the battery when performing resistance tests to avoid damaging the multimeter.

1. Disconnect the battery; then disconnect the two-wire connector at the steering post.
2. Set the meter selector to the OHMS position; then connect the black meter lead to the black wire and the red meter lead to the yellow/black wire.
3. Compress the clutch lever. The meter should show less than 1 ohm. Release the clutch lever and verify that the meter shows an open circuit.

5

Magneto Coils

■NOTE: All peak voltage tests should be made using the Fluke Model 73 Multimeter (p/n 0644-191) with Peak Voltage Reading Adapter (p/n 0644-307). If any other type of tester is used, readings may vary due to internal circuitry.

■NOTE: The battery must be at full charge for this test.

PEAK VOLTAGE (Charging Coil - Output)

1. Set the meter selector to the DC Voltage position.
2. Connect the red tester lead to the positive battery post; then connect the black tester lead to the negative battery post.
3. With the engine running at a constant 5000 RPM (with the headlights on), the meter must be within specification.

⚠ **CAUTION**

Do not run the engine at high RPM for more than 10 seconds.

■NOTE: If voltage is lower than specified, test Charging Coil - No Load.

VOLTAGE (Charging Coil - No Load)

■NOTE: The peak voltage reading adapter must be disconnected for this test.

The connector is the black one on the left side near the voltage regulator.

■NOTE: Test the connector that comes from the engine.



SP084A

1. Set the meter selector to the AC Voltage position.
2. Test between the three brown wires for a total of three tests.

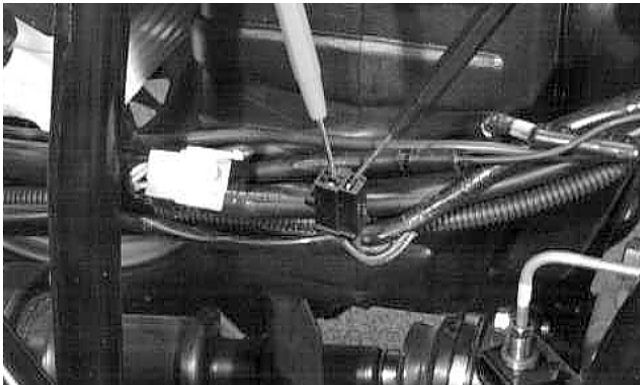

AR630D

3. With the engine running at a constant 5000 RPM, all wire tests must show 65+ AC volts.

CAUTION

Do not run the engine at high RPM for more than 10 seconds.

■NOTE: If both charging coil tests failed, check all connections, etc., and test again. If no voltage is present, replace the stator assembly.

RESISTANCE (Charging Coil)

CAUTION

Always disconnect the battery when performing resistance tests to avoid damaging the multimeter.

1. Set the meter selector to OHMS position.
2. Test between the three brown wires for a total of three tests.
3. The meter reading must be within specification.

RESISTANCE (Trigger Coil)

CAUTION

Always disconnect the battery when performing resistance tests to avoid damaging the multimeter.

1. Set the meter selector to the OHMS position.
2. Connect the red tester lead to the green wire; then connect the black tester lead to the blue wire. The meter reading must be within specification.

PEAK VOLTAGE (Magneto Coil - Trigger)

1. Set the meter selector to the DC Voltage position.
2. Connect the red tester lead to the green wire; then connect the black tester lead to the blue wire.
3. Crank the engine over using the electric starter.
4. The meter reading must be within specification.

Starter Motor

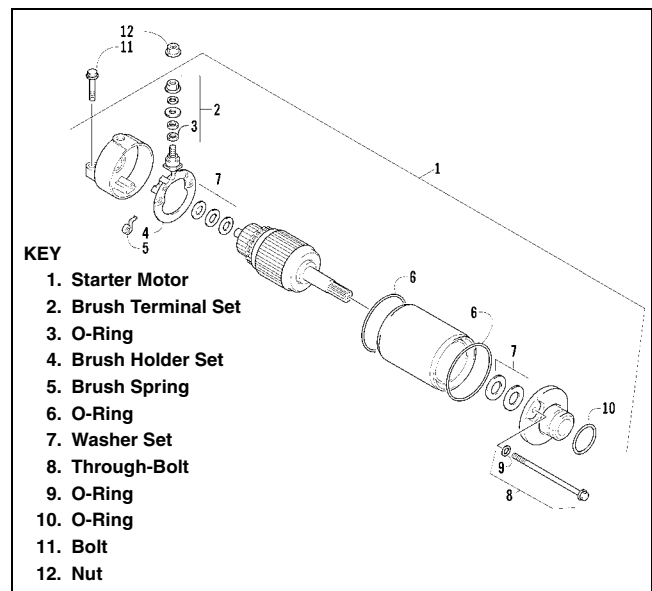

0739-228

REMOVING/DISASSEMBLING

1. Disconnect the battery.

⚠ CAUTION

Always disconnect the negative battery cable from the battery first; then disconnect the positive cable.

2. Remove the nut securing the positive cable to the starter; then remove the cable from the starter.
3. Remove the cap screws securing the starter to the crankcase; then remove the starter.
4. For assembly purposes, scribe a line across the outside of the starter assembly.



AR652D

5. Remove the two through-bolts securing the starter components. Account for the O-rings.
6. Remove the left-side cover from the starter housing. Account for washers and housing O-ring.
7. Remove the right-side cover. Account for washers and housing O-ring.
8. Slide the armature free of the starter housing.
9. Remove the nut from the positive post. Account for the lock washer, flat washer, a fiber washer, and an O-ring.
10. Bend the two positive brushes outward; then remove the brush holder. Account for two brush springs and brushes.

CLEANING AND INSPECTING

NOTE: Whenever a part is worn excessively, cracked, or damaged in any way, replacement is necessary.

1. Thoroughly clean all components except the armature and brushes in parts-cleaning solvent; then dry with compressed air.

⚠ CAUTION

Do not wash the armature and brushes in any kind of solvent. Use only compressed air and a clean dry, lint-free cloth.

www.mymowerparts.com

2. Inspect all threaded areas for damage or stripped threads.
3. Inspect the brush holder assembly and brushes for damage or wear. Using a caliper, measure the length of the brushes. If brush measurement is less than 10.1 mm (0.40 in.), replace with new brushes and brush springs as a set.
4. Inspect the brush leads for cracks, wear, or fraying. If any of these conditions exist, replace with new brushes and brush springs as a set.
5. Inspect the left-side cover bushing for wear.
6. Inspect the right-side cover bushing for wear.
7. Inspect the brass commutator end of the armature for any burned spots or damage. If the commutator is lightly burned or damaged, the armature must be replaced. This is a molded commutator and turning it down in a lathe should not be attempted.

⚠ CAUTION

Do not use emery cloth to clean the commutator as emery particles will become imbedded in the brass commutator resulting in a short circuit. Use only #200 grit sandpaper.

8. Inspect the commutator end of the armature for buildup in the grooves. Carefully remove any buildup by undercutting using a thinly ground hacksaw blade. Do not undercut any deeper than the original groove which can be seen by looking at the end of the commutator.
9. Using a caliper, measure the undercut. Maximum undercut groove must be 0.2 mm (0.008 in.).

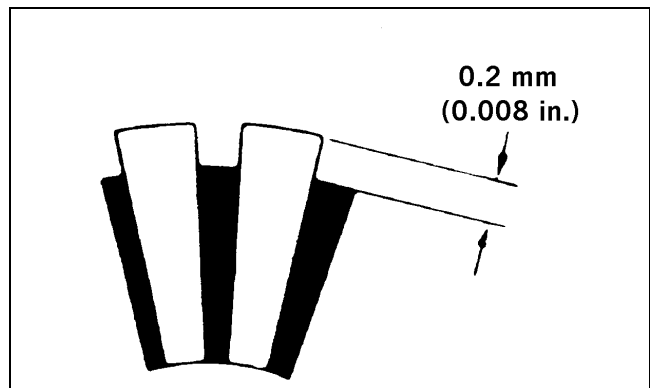

ATV-1054

⚠ CAUTION

Buildup in the grooves must be removed to prevent any chance of an electrical arc between individual sections of the commutator.

10. Inspect the commutator for shorting using a multimeter and the following procedure.
 - A. Set the selector to the OHMS position.
 - B. Touch the black lead to the armature shaft.

- C. Using the red tester lead, probe the commutator end of the armature. The meter indicator should not change. If the indicator shows resistance, the armature is shorted and must be replaced.
11. Inspect the armature for shorting using a “growler” and the following procedure.
- A. Place the armature in the “growler.”
- B. While holding a metal strip on the armature, rotate the armature an entire revolution. If the metal strip vibrates at any point on the armature, the armature is shorted and must be replaced.

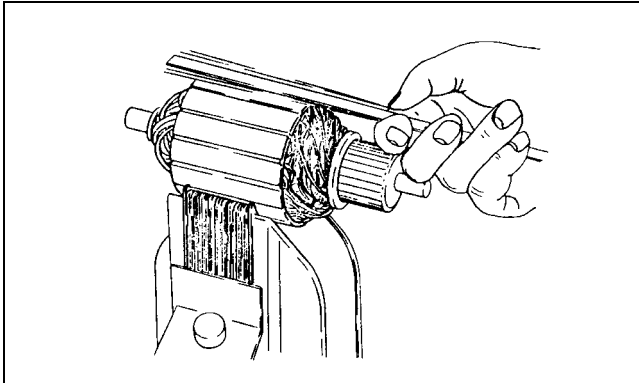

0725-653

12. Inspect the ground brushes to make sure they are properly grounded. Use a multimeter and the following procedure.
- A. Set the selector to the OHMS position.
- B. Touch the black tester lead to a ground brush.
- C. Touch the red tester lead to the brush holder assembly.

■NOTE: If no resistance is indicated, check the ground connection for tightness and for cleanliness. If there is still no meter indication, replace the brush assembly.

ASSEMBLING/INSTALLING

1. Align the tab on the brush holder with the notch in the right-side cover; then install the holder.
2. On the positive post, install an O-ring washer, a fiber washer, a flat washer, and a lock washer. Secure with the nut.
3. Install the armature into the starter housing; then while holding the brushes out, slide the commutator into the brush holder.
4. Apply a small amount of grease to the right-side cover bushing; then install the cover on the starter housing making sure the O-ring is in place and the reference marks align.
5. Install the washer set on the armature shaft; then install the housing O-ring on the starter housing.

6. Apply a small amount of grease to the left-side cover bushing.
7. Place the left-side cover onto the starter housing making sure the housing O-ring is in place and it seats properly.
8. Apply red Loctite #271 to the threads of the two through-bolts and install. Tighten to specification (see Section 10).
9. Apply a small amount of grease to the O-ring seal on the starter; then install the starter into the crankcase. Secure with cap screws and wiring forms. Tighten cap screws securely.
10. Secure the positive cable to the starter with the nut and tighten to specification (see Section 10).
11. Connect the battery making sure to connect the positive cable first.

TESTING VOLTAGE

Perform this test on the starter motor positive terminal.

■NOTE: The ignition switch must be in the ON position, the emergency stop switch in the RUN position, the transmission in the neutral position, and the clutch lever compressed.

1. Set the meter selector to the DC Voltage position.
2. Connect the red tester lead to the starter terminal; then connect the black tester lead to ground.
3. With the starter button depressed, the meter must show battery voltage and the starter motor should operate.



AR607D

■NOTE: If the meter showed battery voltage but the starter did not operate or operated slowly, inspect battery voltage (at the battery), starter motor condition, and/or ground connections.

■NOTE: If the meter showed no battery voltage, inspect the main fuse, ground connections, starter motor lead, battery voltage (at the battery), or the switches.

Starter Relay

VOLTAGE

1. Remove the seat.
2. Set the meter selector to DC Voltage position; then connect the red tester lead to the battery side of the starter relay and the black tester lead to the starter cable side of the starter relay.
3. The meter must show battery voltage.

■NOTE: If the meter showed no battery voltage, check the battery for charge or battery to solenoid connections.

4. Turn the ignition switch to the ON position, compress the clutch lever, and depress the starter button.
5. The meter must show 0 DC volts and the starter motor should run.

■NOTE: If the meter shows voltage, replace the starter relay. If the meter shows battery voltage, continue with step 6.

6. Connect the red tester lead to the yellow/black wire on the starter relay; then connect the black tester lead to ground.
7. Compress the clutch lever; then depress the starter button.
8. The meter should show battery voltage.

■NOTE: If the meter shows battery voltage, the starter relay is defective. If the meter does not show battery voltage, troubleshoot the starter switch, emergency stop switch, clutch lever position, or the ignition switch.

CDI Unit

The CDI is located beneath the left rear fender near the voltage regulator.

■NOTE: The CDI unit is not a serviceable component. If the unit is defective, it must be replaced.

The CDI is rarely the cause for electrical problems; however, if the CDI is suspected, substitute another CDI unit to verify the suspected one is defective.

■NOTE: Prior to replacing the CDI unit to assure the CDI unit is defective, it is advisable to perform a CDI peak voltage test (see Ignition Coil in this section) and/or perform a continuity test of the wiring harness from the CDI connector to the CDI unit.

Regulator/Rectifier

The regulator/rectifier is located under the left rear fender on the upper frame rail.

■NOTE: Before replacing the regulator/rectifier, perform the following checks.

1. Clean and tighten all battery connections; then clean and inspect the three-wire connector from the magneto charging coil.



SP084A

2. Perform the Peak Voltage (Charging Coil - Output) check under the Magneto Coils sub-section.

■NOTE: If the voltage is too high, recheck the battery connections, battery condition, or replace the regulator/rectifier.

3. Perform the Voltage (Charging Coil - No Load) check under Magneto Coils sub-section.

■NOTE: If the charge coil test is within specifications, replace the regulator/rectifier.

Headlights

The headlights are halogen bulbs with two-wire plug connectors. The headlight housing contains two high beam and one low beam bulb assemblies.

⚠ WARNING

Do not touch halogen bulbs while power is applied as severe burns may result.

■NOTE: The center bulb is the low beam one.

1. Turn the ignition switch to the lights position; then note which bulb/bulbs do not illuminate. Be sure to check both high beam and low beam positions.
2. Disconnect the two-wire plug connector from the appropriate bulb; then select the DC Voltage position on the multimeter.
3. Connect the black tester lead to the black wire; then connect the red tester lead to the white wire (high beam) or the yellow wire (low beam).
4. The meter should show 12 DC volts.

■NOTE: If the meter shows 12 DC volts, replace the bulb. If the meter shows 0 volts, check the headlight harness adapter.

Taillight - Brakelight

The connector is the 3-prong one located under the rear body assembly.

BULB VERIFICATION

■NOTE: Perform this test on the taillight-brakelight side of the connector. Also, a 12-volt external power supply (jumper) will be needed.

1. Connect the power supply (positive) to the yellow wire; then connect the power supply (negative) to the brown wire.
2. The taillight should illuminate.
3. With the negative power supply still connected, connect the positive supply wire to the red wire.
4. The brakelight should illuminate.

■NOTE: If either the taillight or brakelight fails to illuminate, inspect the bulb, the connectors, or the component wiring harness.

VOLTAGE (Taillight)

■NOTE: Perform this test on the harness side of the connector. Also, the ignition switch should be in the LIGHTS position.

1. Set the meter selector to the DC Voltage position.
2. Connect the red tester lead to the gray wire; then connect the black tester lead to the white/black wire.
3. With the ignition key in the LIGHTS position, the meter must show battery voltage.

■NOTE: If the meter shows no voltage, inspect fuses, wiring harness, connectors, and switches. If the meter shows battery voltage, replace the bulb.

VOLTAGE (Brakelight)

■NOTE: Perform this test on the main harness side of the connector. Also, the ignition switch should be in the ON position and the brake (either foot pedal or hand lever) must be applied.

■NOTE: Make sure the brake lever (front) and brake pedal (rear) are properly adjusted for this procedure.

1. Set the meter selector to the DC Voltage position.
2. Connect the red tester lead to the black/white wire; then connect the black tester lead to the white/black wire.
3. With either brake applied, the meter must show battery voltage.

■NOTE: If the meter shows no voltage, inspect bulb, fuses, wiring harness, connectors, and switches. If the meter shows battery voltage, replace the bulb.

Throttle Position Sensor (TPS)

RESISTANCE

1. Set the meter selector to the OHMS position.
2. Disconnect the three-pin connector on the TPS harness; then connect the red tester lead to the yellow-wire pin and the black tester lead to the black-wire pin.

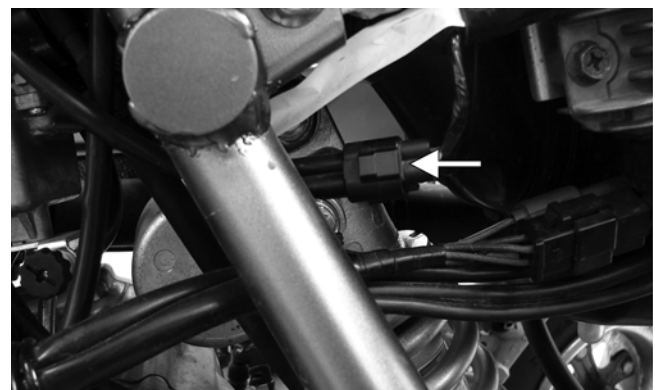

SP441A

3. With the throttle in the closed position, the meter must read 892-1208 ohms.

4. With the throttle in the full-open position, the meter must read 3.7-4.9K ohms.
5. With the red tester lead connected to the yellow-wire pin, connect the black tester lead to the blue-wire pin.
6. With the throttle in the closed position, the meter must read 4.25-5.75K ohms.
7. With the throttle in the full-open position, the meter must read 1509-2041 ohms.

REMOVING

1. Disconnect the three-pin connector on the TPS harness from the main wiring harness.
2. Remove the two machine screws securing the TPS to the carburetor; then remove the TPS.

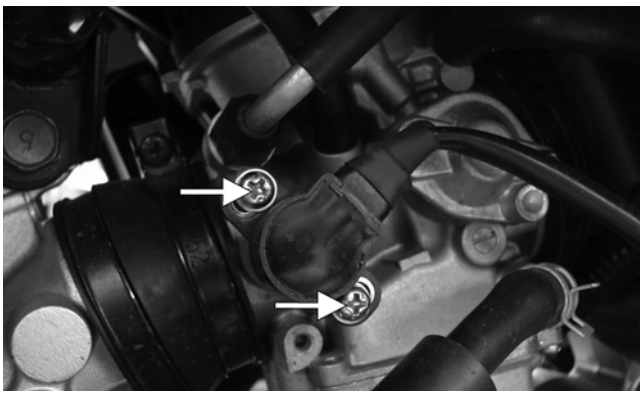

SP442A

INSTALLING

1. Place the TPS into position on the carburetor; then secure with the two machine screws.

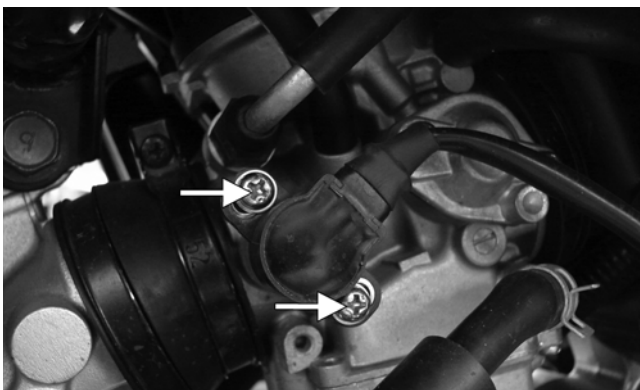

SP442A

2. Connect the three-pin connector on the TPS harness to the main wiring harness.

■NOTE: No adjustments can be made to the TPS.

Ignition Timing

The ignition timing cannot be adjusted; however, verifying ignition timing can aid in troubleshooting other components. To verify engine timing, use the following procedure.

1. Attach Timing Light (p/n 0644-197) to the spark plug high tension lead; then remove the timing inspection plug from the left-side magneto cover.
2. With Tachometer (p/n 0644-275) connected, start the engine and run at the specified RPM.
3. Ignition timing should be according to specification.
4. Install the timing inspection plug.

If ignition timing cannot be verified, the rotor may be damaged, the key may be sheared, the trigger coil bracket may be bent or damaged, the CDI unit may be faulty, or the TPS may be disconnected or faulty.

SECTION 6 - DRIVE SYSTEM

TABLE OF CONTENTS

Drive System	6-2
Rear Drive Assembly Schematics	6-2
Rear Drive Axle	6-2

Drive System

■NOTE: Some photographs and illustrations used in this section are used for clarity purposes only and are not designed to depict actual conditions.

■NOTE: Critical torque specifications are located in Section 10.

SPECIAL TORQUE WRENCH ADAPTER

A special adapter is needed to properly tighten the drive axle nuts to specifications.

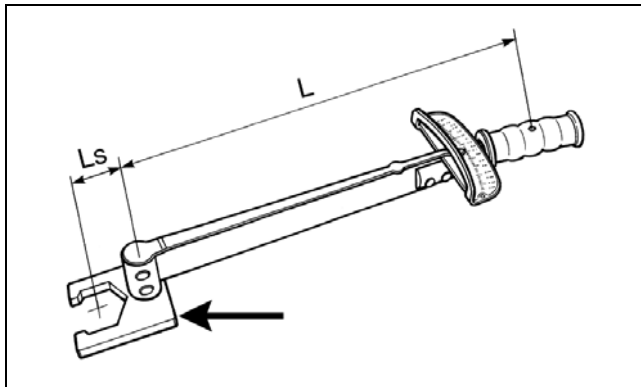

ATV2189

Rear Drive Assembly Schematics

LEFT REAR WHEEL ASSEMBLY

KEY

1. Sprocket Hub
2. Sprocket
3. Washer
4. Bolt
5. Washer
6. Washer
7. Axle Nut
8. Hub
9. Tire
10. Wheel
11. Nut
12. Washer
13. Hub Nut
14. Cotter Pin
15. Valve Assy

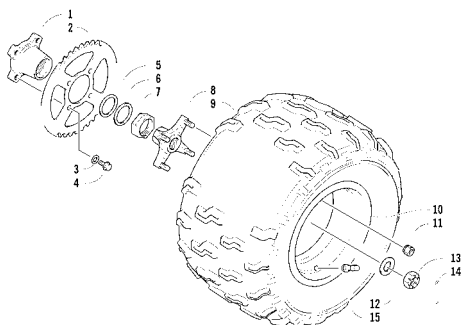

0741-477

RIGHT REAR WHEEL ASSEMBLY

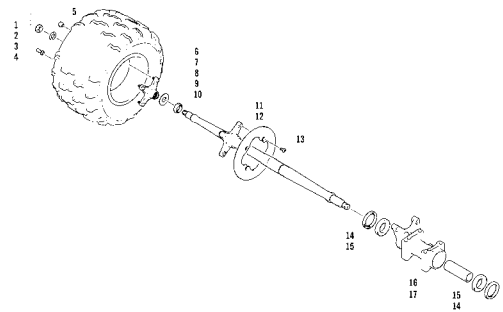

KEY

- | | | |
|---------------|----------------|------------------|
| 1. Cotter Pin | 7. Wheel | 13. Bolt |
| 2. Hub Nut | 8. Hub | 14. Dust Seal |
| 3. Washer | 9. Washer | 15. Bearing |
| 4. Valve Assy | 10. Axle Nut | 16. Axle Housing |
| 5. Nut | 11. Axle | 17. Spacer |
| 6. Tire | 12. Brake Disc | |

0741-476

Rear Drive Axle

REMOVING

1. Secure the ATV on a support stand to elevate the rear wheels.

⚠ WARNING

Make sure the ATV is solidly supported on the support stand to avoid injury.

2. Apply and lock the parking brake; then remove the wheels.
3. Loosen (but do not remove) the four cap screws on the swing arm; then turn the adjuster nut counter-clockwise to slacken the chain.

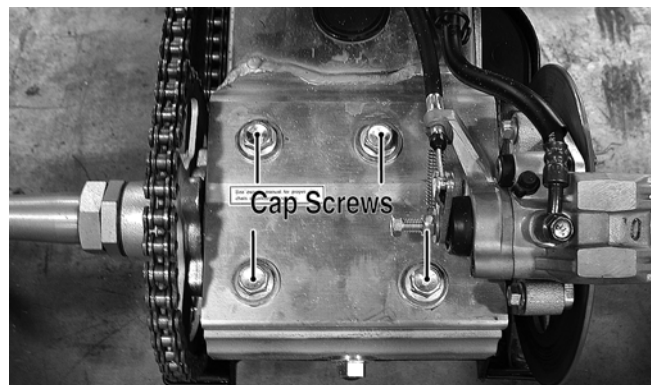

SP061A

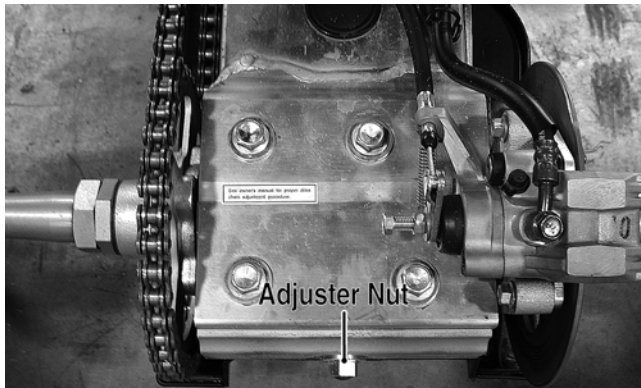

SP061B

4. Remove the rear wheel hubs; then remove the left-side axle nuts (1). Account for two concave washers (2).

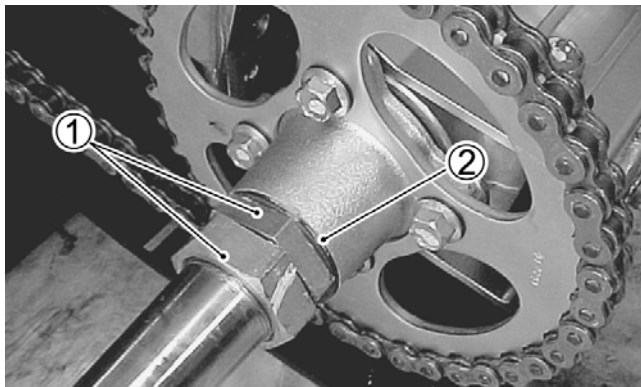

SP315

5. Remove the sprocket and sprocket hub assembly; then remove the brake caliper and lay aside.

■NOTE: Do not apply pressure to the brake pedal with the caliper removed. The brake piston will be pushed out and brake fluid will be spilled.

6. Slide the axle to the right and out of the axle housing; then remove the brake disc from the flange.

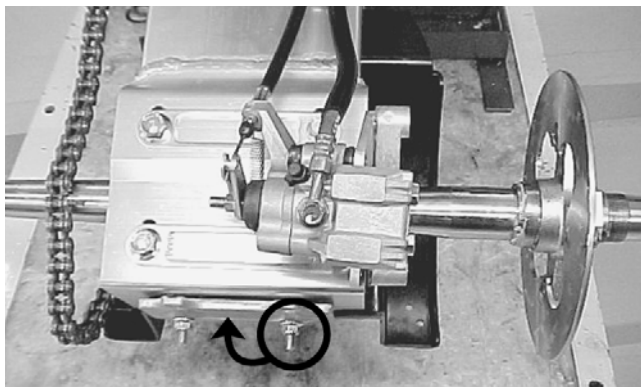

SP316

■NOTE: It is not necessary to remove the right-side axle nut.



SP317

■NOTE: Do not attempt to remove the brake disc flange. The axle and brake flange are an assembly.

7. Remove the four swing-arm cap screws; then remove the adjuster nut (from step 3).

8. Remove the axle housing from the swing arm.

CLEANING AND INSPECTING

1. Inspect the sprocket teeth for wear. If they are worn as shown, replace the engine sprocket, rear sprocket, and drive chain as a set.

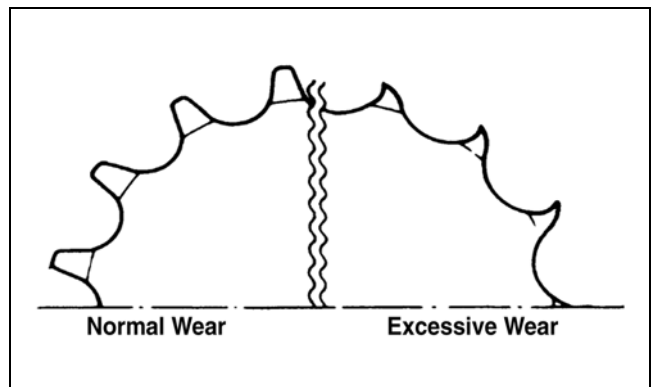

ATV2185

2. Measure the rear axle runout as shown using a V blocks and a dial indicator. If the axle runout exceeds 6 mm (0.24 in.), the axle must be replaced.

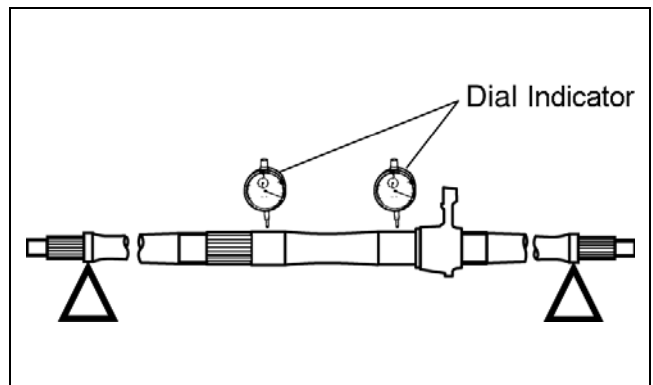

ATV2186

3. Inspect the dust seals for wear or damage. If any defect is found, replace the dust seal.

4. Inspect the axle bearings by rotating them by hand. If any roughness, binding, or excessive looseness is found, replace the axle bearings.

■NOTE: If the axle bearings are replaced, replace the dust seals with new ones. Always pack the bearings with a good quality wheel bearing grease.

REMOVING BEARINGS

1. Remove the dust seal using an appropriate seal removal tool; then using an appropriate bar (1), drive the bearings out of the axle housing. Account for one spacer.

■NOTE: Do not reuse bearings after removal.

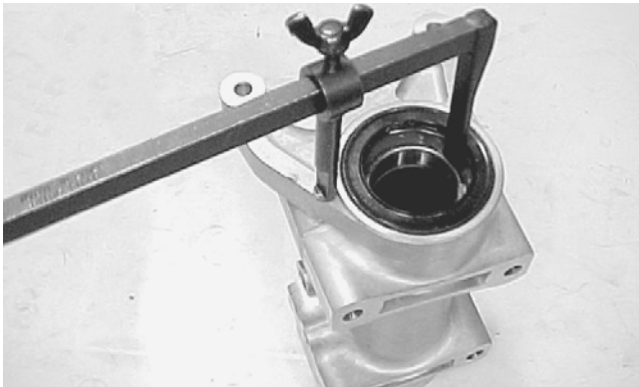

SP318

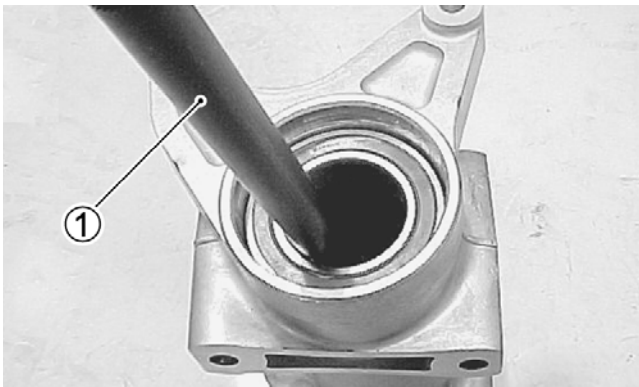

SP319

2. Clean the axle housing and inspect for cracks, elongated holes, and wear in bearing bores.

INSTALLING BEARINGS

1. Pack the new bearings with a good quality wheel bearing grease; then install the right bearing (1) first using an appropriate bearing installer. The sealed side of the bearing must be directed outward.

2. Install the spacer; then install the left bearing (2).

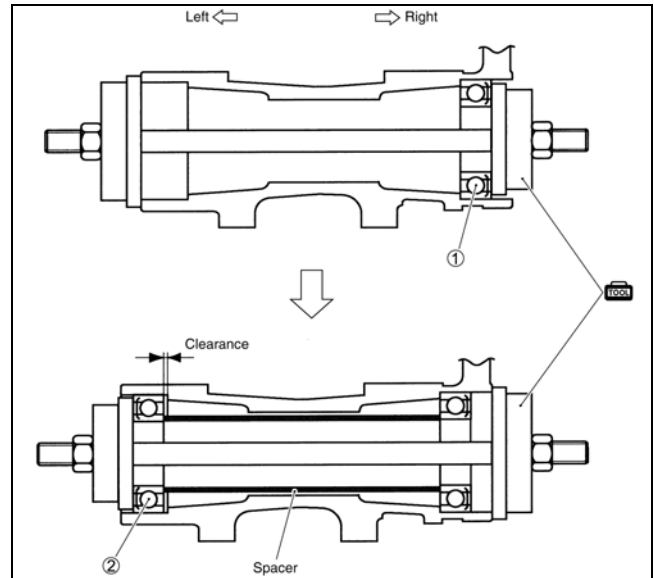

ATV2187

3. Install new dust seals and lightly coat with grease.

INSTALLING

1. Install the axle housing in the swing arm; then install and finger-tighten the four cap screws.

2. Install the adjuster nut loosely; then install the brake disc applying red Loctite #271 to the Allen-head cap screws. Tighten to specifications.

3. Slide the axle into the axle housing from the right side; then apply multipurpose grease to all splined areas of the axle.



SP320



SP321

- Apply Three Bond Sealant to the left and right ends of the sprocket hub; then install the hub on the axle.

■NOTE: If the sprocket was removed, see Section 2 for sprocket installation procedure.

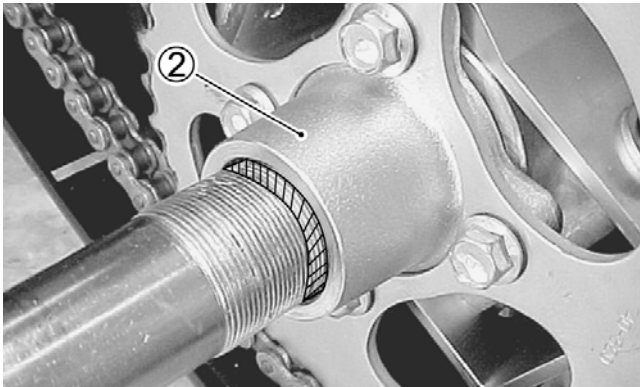

SP322

- On the left-side, install the concave washers (3); then apply red Loctite #271 to the threads on the axle and using the torque wrench adapter, tighten the inner axle nut (4) to the calculated specification.

■NOTE: It is necessary to calculate the torque value using the following formula due to the offset of the special tool used to tighten the axle nuts.

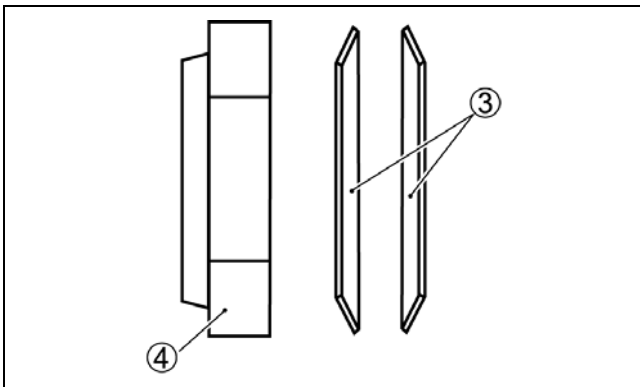

ATV2188

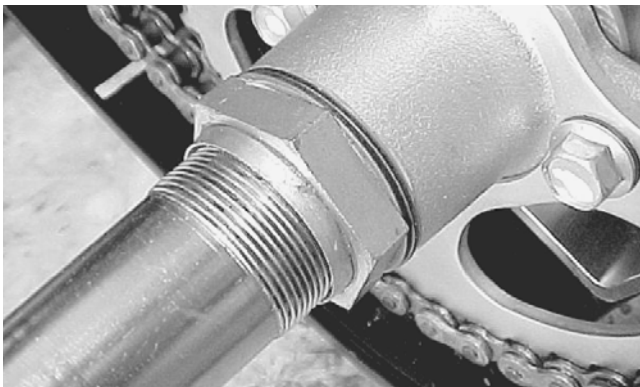

SP323

$$\frac{L \times Ts}{L + Ls} = T$$

T: Torque wrench reading to be calculated

Ts: Specified torque value (130 ft-lb)

Ls: Tool offset length (center to center)

L: Length of torque wrench (handle pivot to head center)

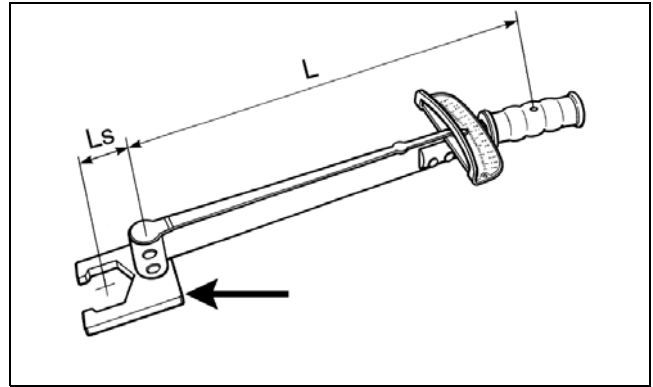

ATV2189

- Install the outer axle nut (5) and tighten to calculated specification.

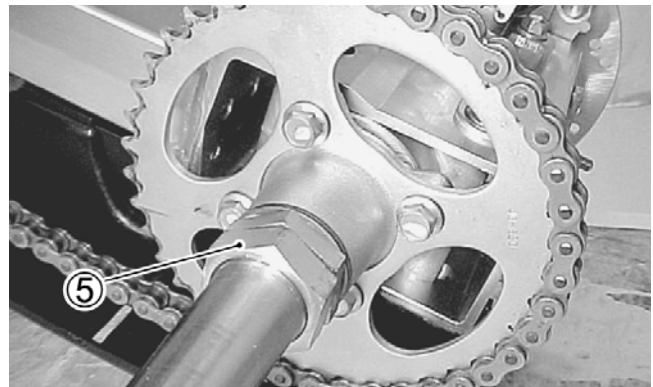

SP324

- Adjust the drive chain (see Section 2); then tighten the four cap screws.
- Install the brake caliper and tighten the mounting cap screws to specifications; then install the wheel hubs and tighten the rear wheel hub nuts to specifications.
- Install the rear wheels and tighten to specifications.

6

SECTION 7 - SUSPENSION

TABLE OF CONTENTS

Suspension Assembly Schematics	7-2
Front Shock Absorbers.....	7-2
Rear Shock Absorber	7-4
Swing Arm.....	7-6
Front A-Arms.....	7-11
Wheels and Tires	7-16

Suspension Assembly Schematics

FRONT SUSPENSION

KEY

1. Shock Absorber
2. Cap Screw
3. Cap Screw
4. Nut
5. A-Arm
6. A-Arm
7. Bearing
8. Bearing
9. Dust Seal
10. Dust Seal
11. Spacer
12. Spacer
13. Cap Screw
14. Nut
15. Washer

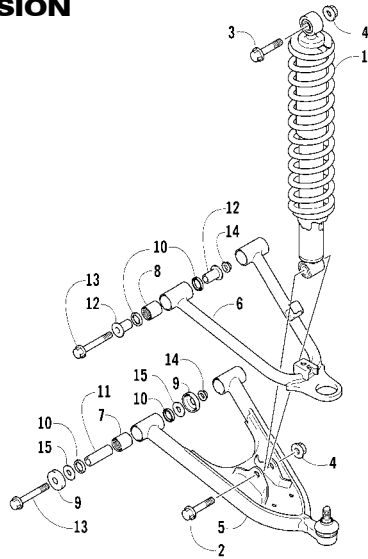

0739-246

REAR SUSPENSION

KEY

1. Front Arm Assy
2. Bearing
3. Bearing
4. Grease Fitting
5. Spacer
6. Dust Seal
7. Bolt
8. Nut
9. Spacer
10. Spacer
11. Bolt
12. Seal
13. Spacer
14. Guard
15. Screw
16. Rear Arm
17. Spacer
18. Bolt
19. Nut
20. Bolt
21. Shock Absorber
22. Bolt

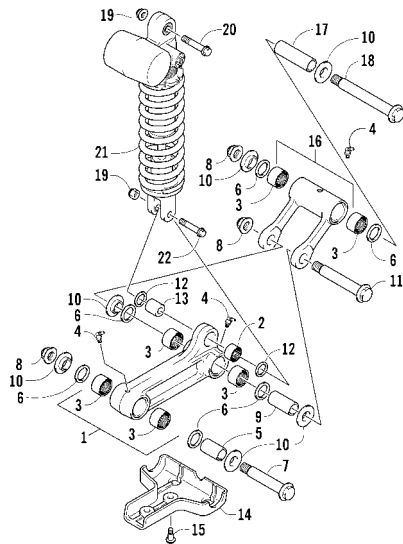

0741-683

SWING ARM

KEY

1. Swing Arm Assy
2. Bearing
3. Bushing
4. Seal
5. Spacer
6. Dust Cover
7. Washer
8. Pivot Shaft
9. Nut
10. Washer
11. Chain Slide
12. Cap Screw
13. Adjuster Plate
14. Adjuster Bolt
15. Washer
16. Circlip
17. Nut
18. Cap Screw
19. Cap Screw
20. Washer
21. Plate
22. Plate
23. Guard
24. Guard
25. Chain Slide
26. Washer
27. Rivet
28. Cap Screw
29. Cap Screw
30. Washer
31. Cap
32. Boot

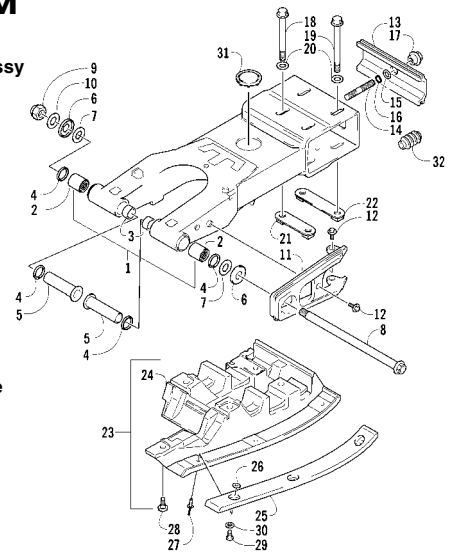

0740-393

Front Shock Absorbers

REMOVING

1. Secure the ATV on a support stand to elevate the wheels and to release load on the suspension.

⚠ WARNING

Make sure the ATV is solidly supported on the support stand to avoid injury.

2. Remove the cap screws and nuts securing each shock absorber to the A-arm and frame.



CD866A

CLEANING AND INSPECTING

■NOTE: Whenever a part is worn excessively, cracked, or damaged in any way, replacement is necessary.

1. Clean the shock absorbers in parts-cleaning solvent.
2. Inspect each shock rod for nicks, pits, bends, and oily residue.
3. Inspect the springs, spring retainers, shock rods, shock bodies, and eyelets for cracks, leaks, and bends.

⚠ WARNING

Do not attempt to disassemble the shock absorbers. They contain high-pressure nitrogen gas and are not serviceable.

■NOTE: Do not dispose of a shock absorber until the high-pressure nitrogen gas is released.

To release gas pressure, remove the valve cap; then using a screwdriver, depress the valve releasing the gas.

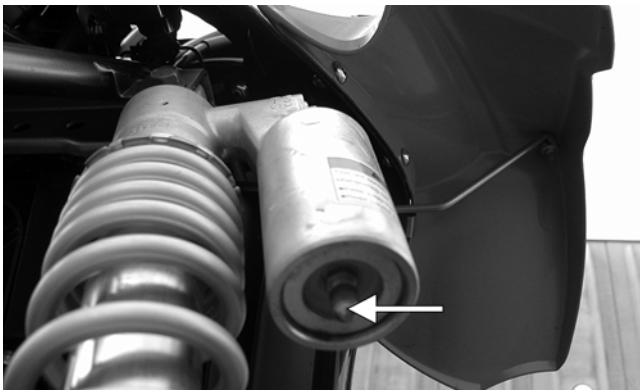

CD866A

WARNING

Direct the valve stem away from your body. Always wear protective eyewear when releasing high-pressure gas.

INSTALLING

1. Place the shock absorber spring over the shock absorber, compress the spring, and install the retainer.
2. Install each shock absorber to the frame and A-arm with cap screws and nuts. Tighten all nuts to specifications (see Section 10).

⚠ CAUTION

Do not tighten the nut beyond the recommended specification or the shock eyelet or mount WILL be damaged.

3. Remove the ATV from the support stand.

ADJUSTING SPRING PRELOAD

The preload is adjustable by changing the spring set length. Using the following procedure, adjust the spring.

1. Loosen the lock nut (1); then adjust the spring set length by turning the adjuster (2).

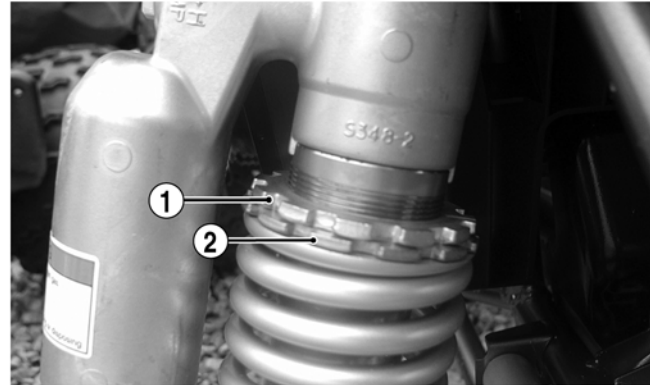

CD835B

SPRING SET LENGTH

STANDARD	MAXIMUM (SOFTTEST)	MINIMUM (STIFFEST)
287.7 mm (11.33 in.)	294.7 mm (11.60 in.)	280.7 mm (11.05 in.)

⚠ WARNING

Do not adjust the spring preload out of the specified range.

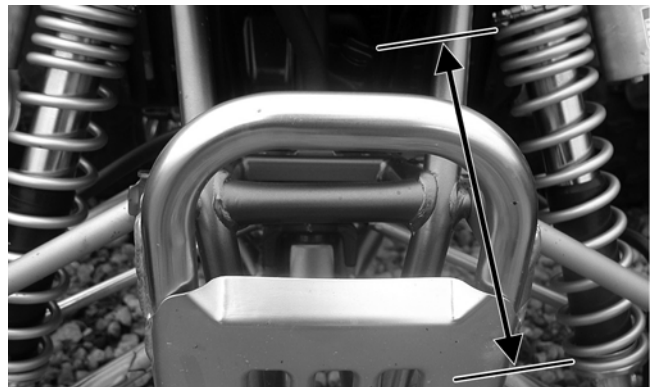

CD837A

3. Tighten the lock nut securely.

ADJUSTING DAMPING FORCE

The compression and rebound damping forces are adjustable. To adjust, use the following procedure.

■NOTE: Do not force the damping adjuster screws or tighten them; damage to the adjusters will occur.

■NOTE: Turning the adjuster screws clockwise increases force; turning them counterclockwise decreases force.

3. Remove the ATV from the support stand.

www.mymowerparts.com



Back to TOC

Back to Section TOC



Rebound

1. Turn the lower damping force adjuster screw (1) fully clockwise.

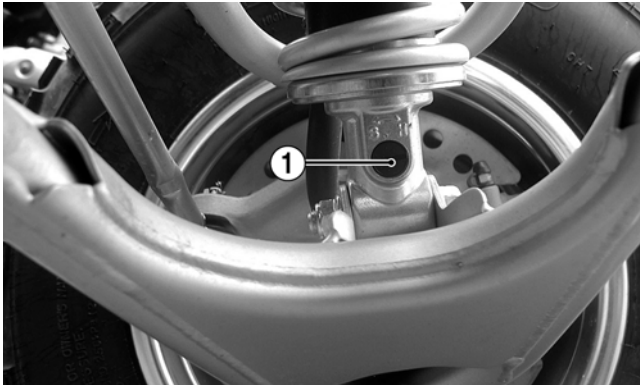

CD834A

2. Turn the adjuster 1 1/2 turns counterclockwise for the "standard" setting.

Compression

1. Turn the upper damping force adjuster screw (2) fully clockwise.



CD833A

2. Turn the adjuster 1 3/4 turns counterclockwise for the "standard" setting.

⚠ WARNING

Always adjust the front shock absorbers equally for spring preload and damping force (rebound/compression). Unequal adjustments could adversely affect handling causing loss of control.

Rear Shock Absorber

■NOTE: Critical torque specifications are located in Section 10.

REMOVING

1. Secure the ATV on a support stand to elevate the wheels and to release load on the suspension.

www.mymowerparts.com

⚠ WARNING

Make sure the ATV is solidly supported on the support stand to avoid injury.

2. Remove the rear arm guard (1); then remove the swing-arm guard (2).

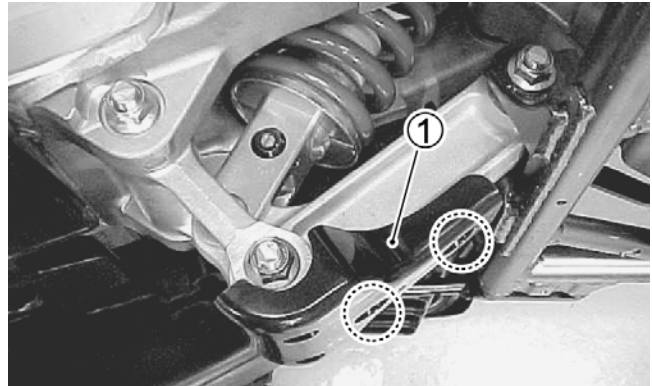

SP325

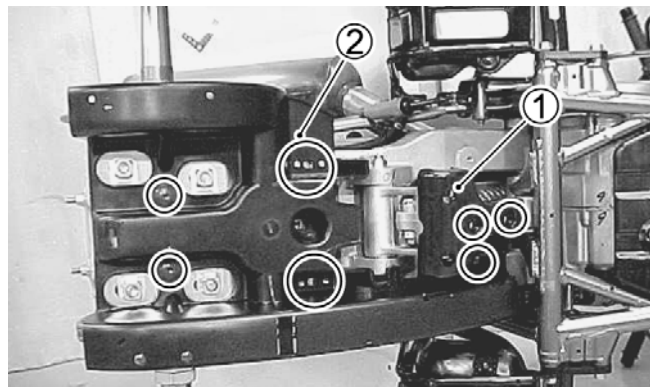

SP326

3. Remove the rear arm lower nut and cap screw (3); then remove the shock absorber nuts and cap screws (4-5).

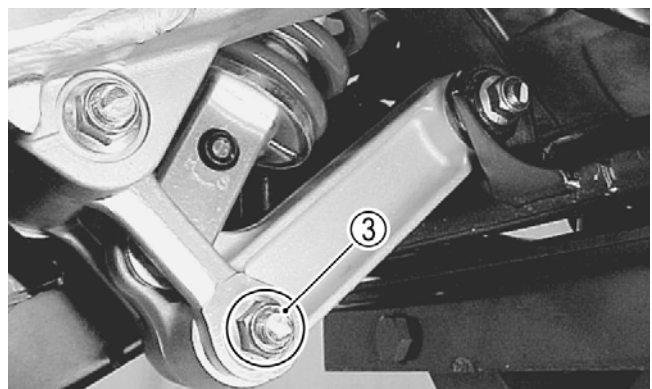

SP327

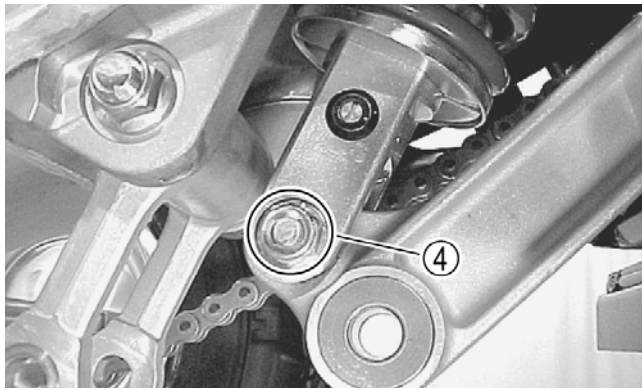

SP328

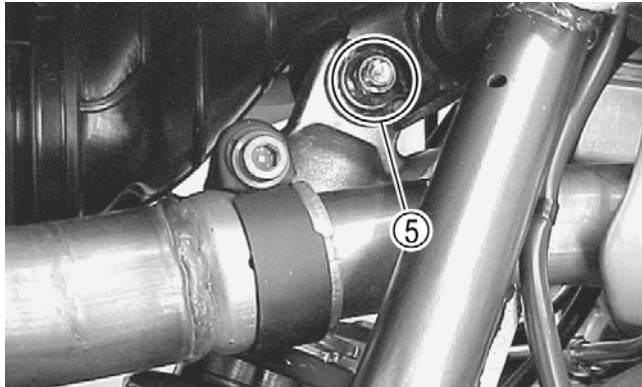

SP329

- Remove the rear shock absorber by lifting up the swing-arm and lowering the shock absorber assembly.

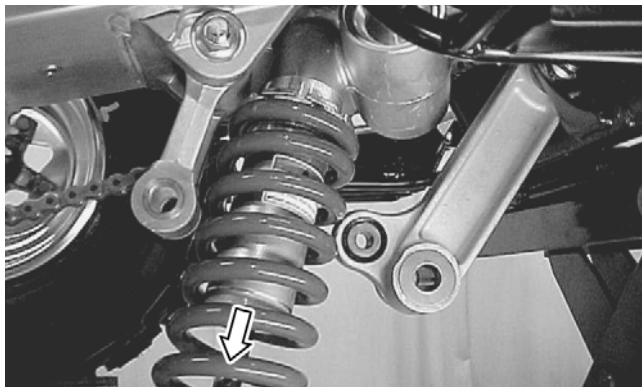

SP330

CLEANING AND INSPECTING

- Clean the shock absorber in parts-cleaning solvent.
- Inspect each shock absorber body and rubber bushing for damage and leaking oil. If any defects are found, replace the shock absorber.

⚠ WARNING

Do not attempt to disassemble the rear shock absorber. It contains high-pressure nitrogen gas and is not serviceable.

■NOTE: Do not dispose of the shock absorber until the high-pressure nitrogen gas is released.

To release gas pressure, remove the valve cap; then using a screwdriver, depress the valve releasing the gas.



SP331

⚠ WARNING

Direct the valve stem away from your body. Always wear protective eyewear when releasing high-pressure gas.

INSTALLING

- Raise the swing-arm and place the shock absorber in position; then install the upper and lower cap screws and nuts.
- Tighten the upper nut (1) and the lower nut (2) to specifications.

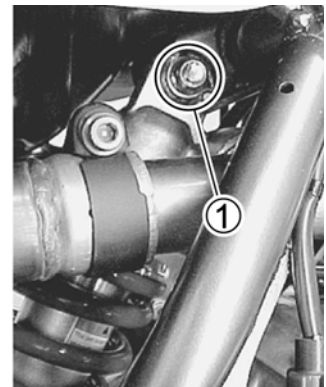

SP332A

- Install the rear arm lower cap screw and nut; then tighten the nut to specifications.

ADJUSTING SPRING PRELOAD

The rear spring preload is adjustable by changing the spring set length. Using the following procedure, adjust the spring.

- Remove the rear shock absorber; then secure the shock absorber in a suitable holding fixture or vise.
- Loosen the lock nut (1); then adjust the spring set length by turning the adjuster (2).

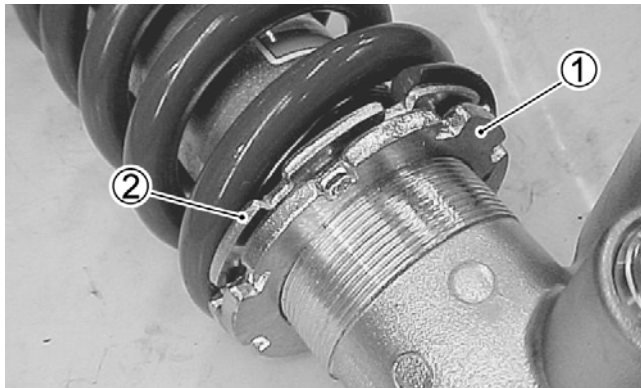

SP334

SPRING SET LENGTH		
STANDARD	MAXIMUM (SOFTTEST)	MINIMUM (STIFFEST)
233 mm (9.17 in.)	238 mm (9.37 in.)	228.5 mm (9.00 in.)

⚠ WARNING
Do not adjust the spring preload out of the specified range.

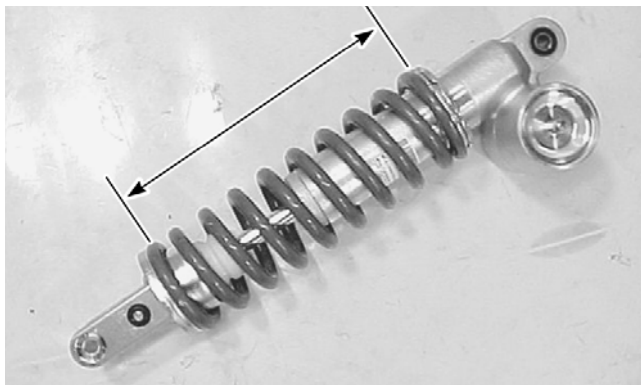

SP335

3. Tighten the lock nut securely.

ADJUSTING DAMPING FORCE

The compression and rebound damping forces are adjustable. To adjust, use the following procedure.

■NOTE: Do not force the damping adjuster screws or tighten them; damage to the adjusters will occur.

■NOTE: Turning the adjuster screws clockwise increases force; turning them counterclockwise decreases force.

Rebound

1. Turn the lower damping force adjuster screw fully clockwise.

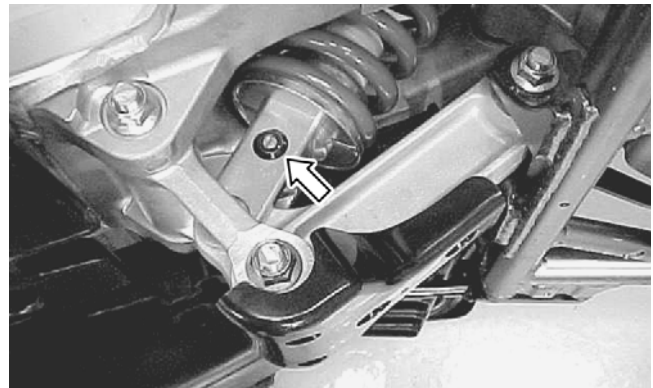

SP336

2. Turn the adjuster 1 1/2 turns counterclockwise for the “standard” setting.

Compression

1. Turn the upper damping force adjuster screw fully clockwise.

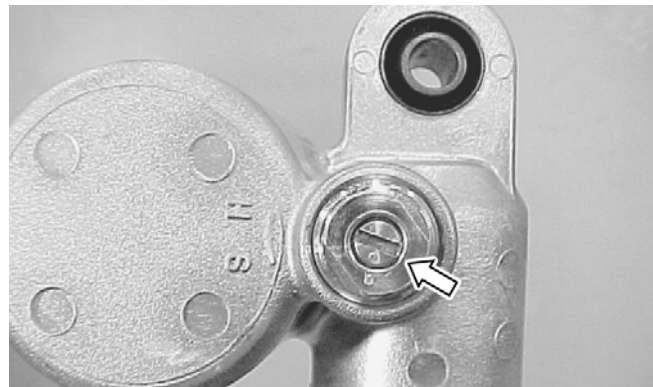

SP337

2. Turn the adjuster two full turns counterclockwise for the “standard” setting.

Swing Arm

REMOVING AND DISASSEMBLING

1. Secure the ATV on a support stand to elevate the wheels and to release load on the suspension.

⚠ WARNING
Make sure the ATV is solidly supported on the support stand to avoid injury.

2. Remove the swing arm guard (1); then remove the rear arm guard (2).

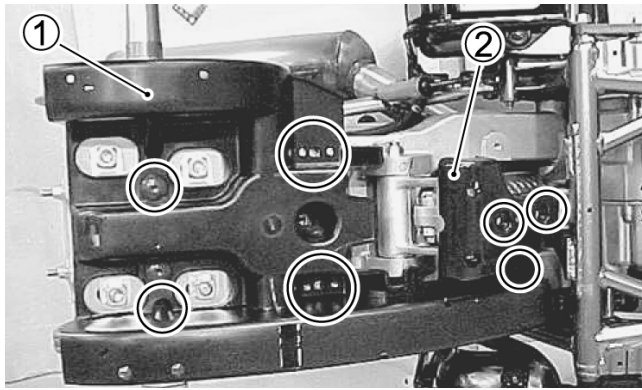

SP338

3. Remove the rear arm (3); then remove the front arm (4).



SP339

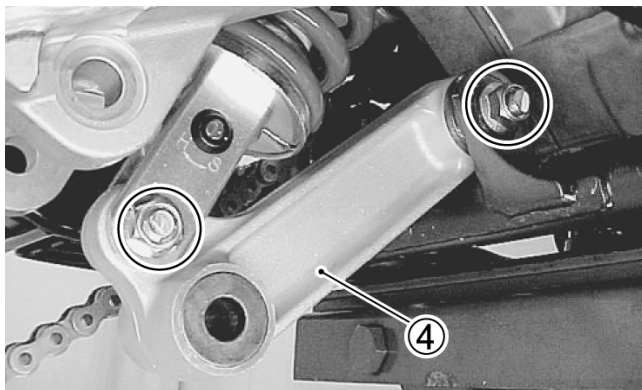

SP340

4. Remove the shock absorber; then remove the rear wheels.

5. Remove the axle housing (see Section 6).

6. Remove the brake hose guide (1); then remove the parking brake cable guide (2).

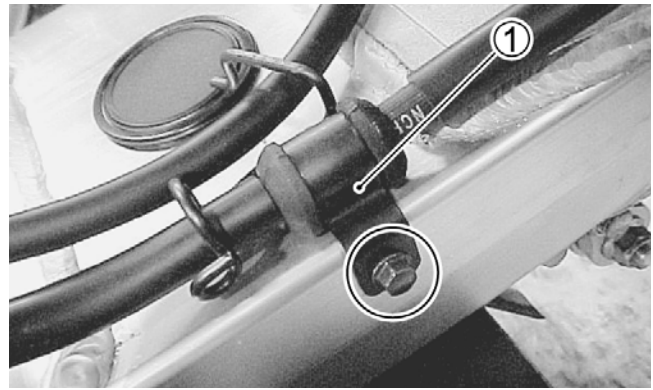

SP341

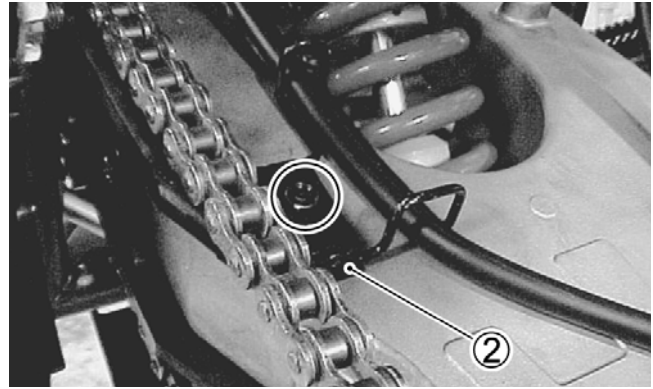

SP342

7. Remove the swing-arm pivot nut; then remove the swing-arm pivot shaft and remove the swing arm.

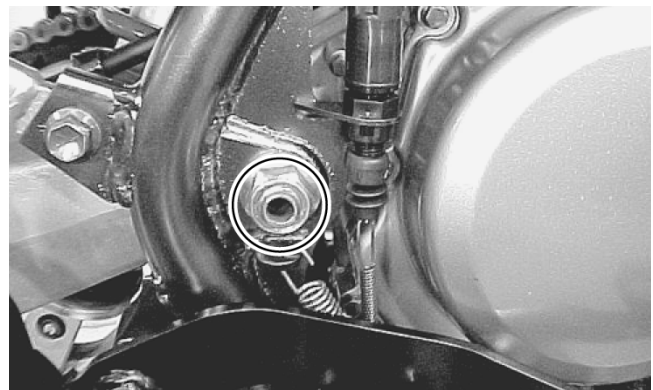

SP343

8. Remove the chain slide.

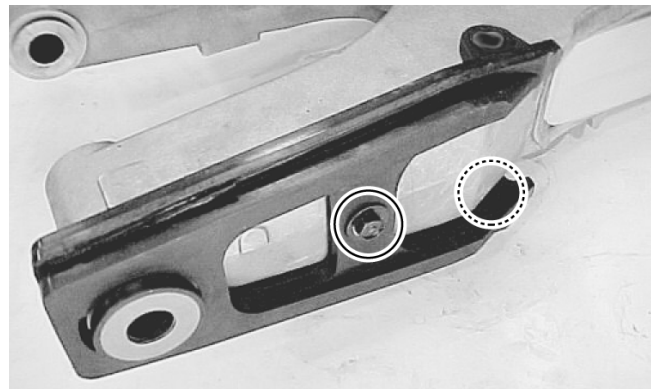

SP344

9. Remove the dust covers (1), washers (2), and spacers (3) from the swing arm; then remove the spacers from the front arm and rear arm.

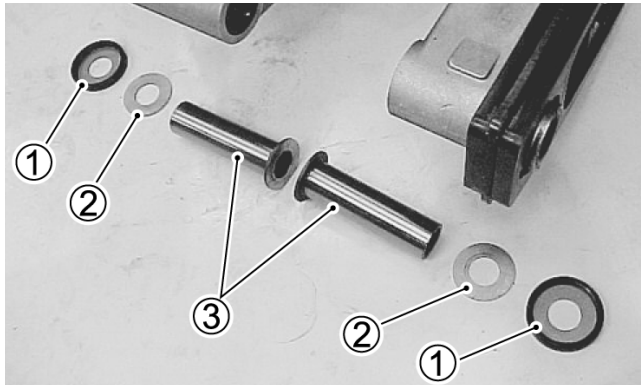

SP345

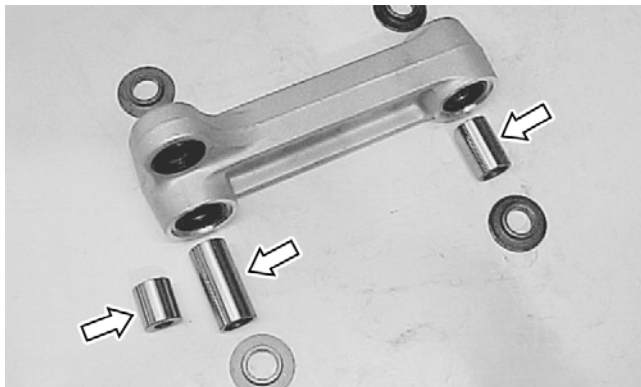

SP346

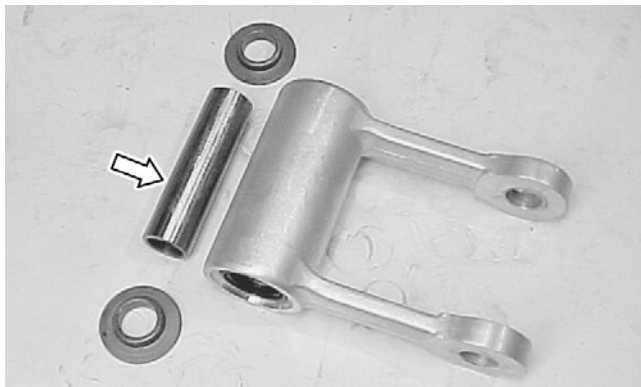

SP347

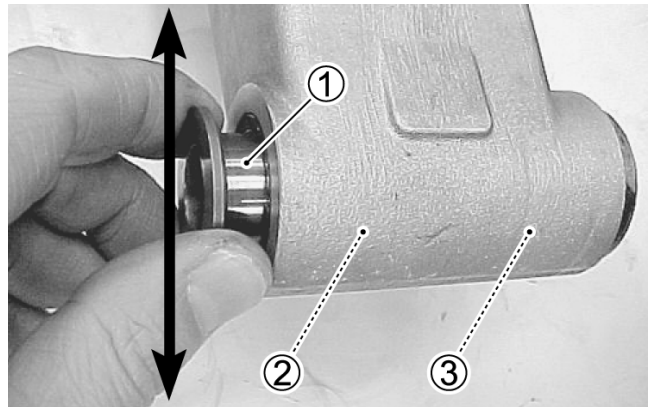

SP348

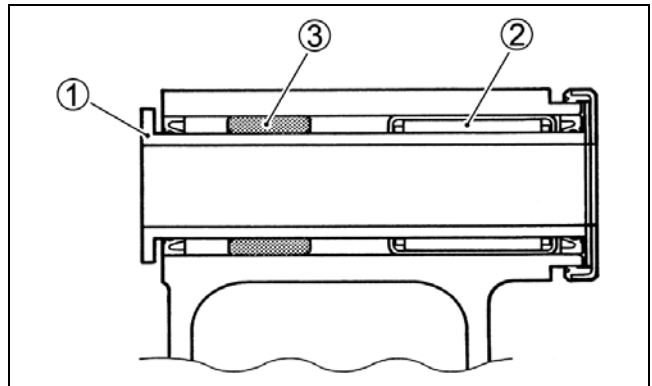

ATV2192

3. Remove the dust seals; then using a bearing remover and slide hammer, remove the worn bearings.



SP349

■NOTE: Removed bearings must be replaced with new ones.

4. Using an appropriate bushing driver, remove the pivot bushing.

CLEANING AND INSPECTING

■NOTE: Whenever a part is worn excessively, cracked, or damaged in any way, replacement is necessary.

1. Inspect the dust covers, seals, and spacers for wear or damage. If any defect is found, they must be replaced.
2. To inspect swing-arm bearings and bushings, insert the spacer (1) into the bearing (2) and bushing (3); then check for excessive play by moving the spacer up and down. If excessive play is noted, the bearing must be replaced.

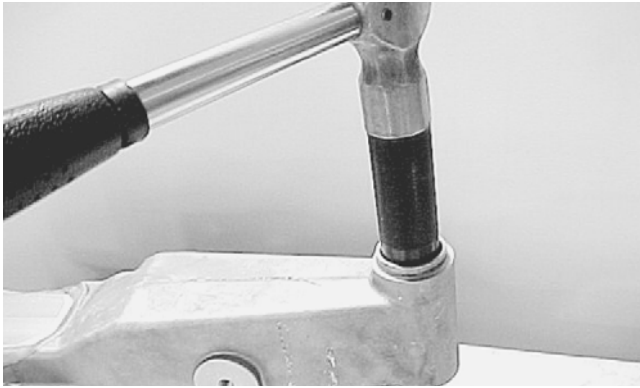

SP350

■NOTE: Removed bushings must be replaced with new ones.

5. To inspect front and rear arm bearings, insert the spacer into the bearing; then check for excessive play by moving the bearing up and down. If excessive play is noted, the bearing must be replaced.

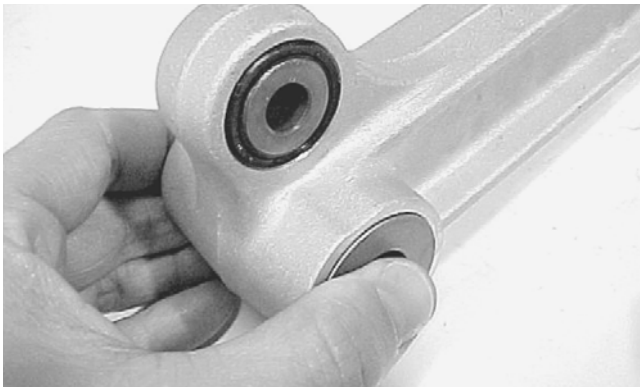

SP351

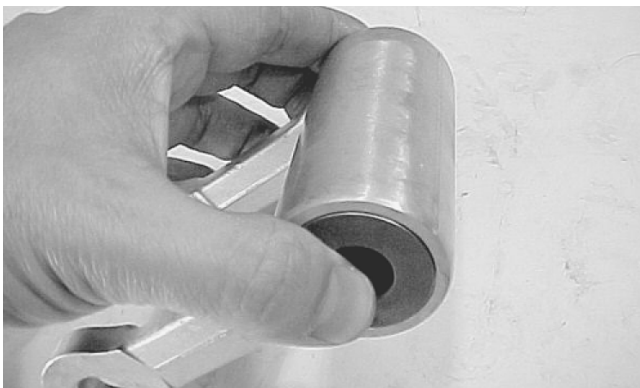

SP352

6. Remove the dust seals; then using a suitable bearing puller and slide hammer, remove the defective bearing.

■NOTE: Removed bearings must be replaced with new ones.

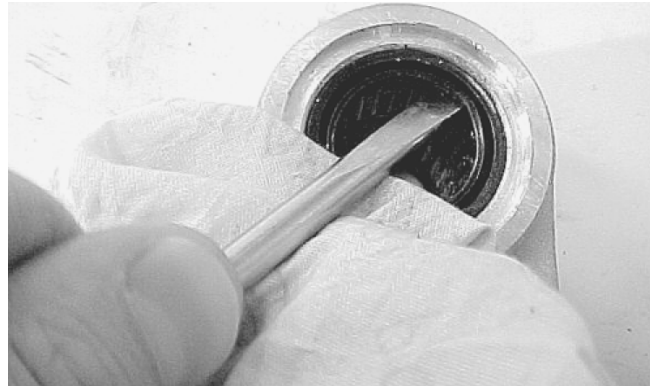

SP353

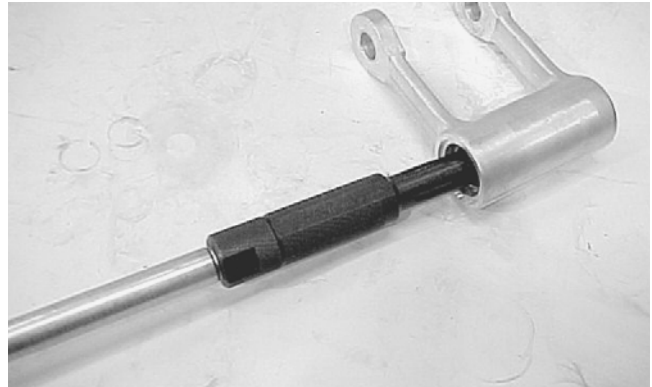

SP354

7. Remove the front arm bearings using a suitable bearing puller set.

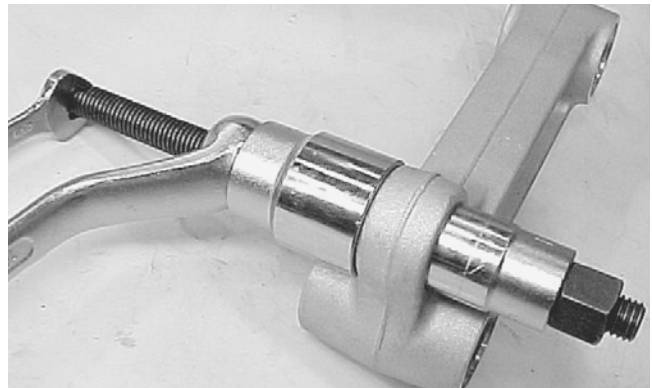

SP355

■NOTE: Removed bearings must be replaced with new ones.

8. To check pivot shaft runout, use a dial indicator. If runout exceeds 0.3 mm (0.01 in.), replace the pivot shaft.

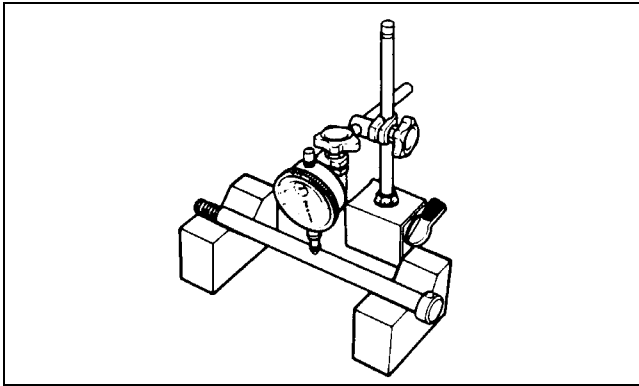

ATV2194

ASSEMBLING AND INSTALLING

■NOTE: Critical torque specifications are located in Section 10.

- Using a suitable bearing installer, press the new bearing into the swing arm pivot to a depth of 5 mm (0.2 in.); then press the bushing into the swing arm pivot to a depth of 12 mm (0.47 in.).

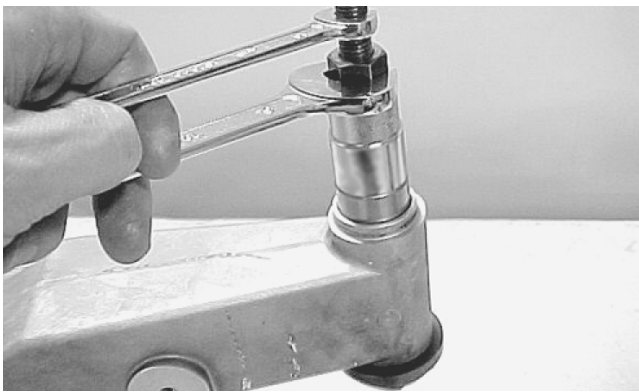

SP356

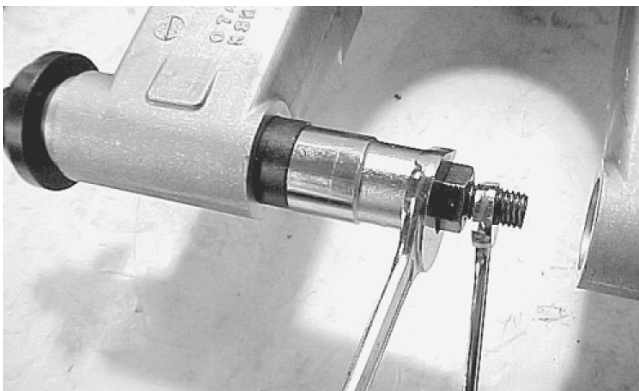

SP357

- Install the dust seals into the swing arm pivot with the stamped marks directed towards the outside; then lubricate the bearing, bushings, and seal lips with multipurpose grease.

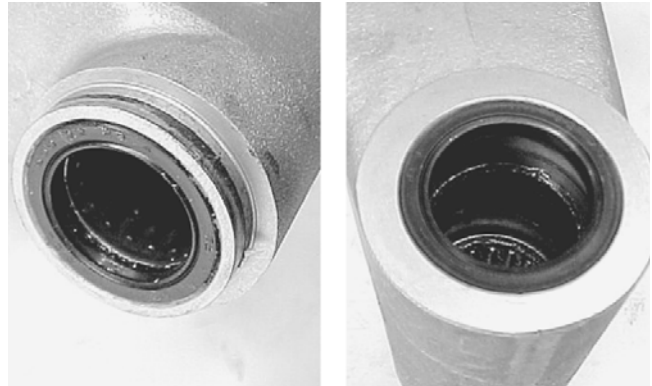

SP358A

- Apply multipurpose grease to the lip of the dust covers; then install the dust covers (1), washers (2), and spacers (3) to the swing arm.

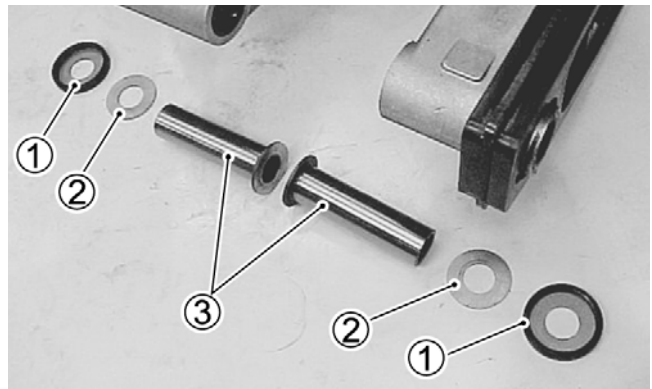

SP360

- Using a suitable bearing installer, install the new rear arm bearings to the specified depth; then install the dust seals coating the seal lips and bearings with multipurpose grease. See the illustration below for the proper bearing depths.

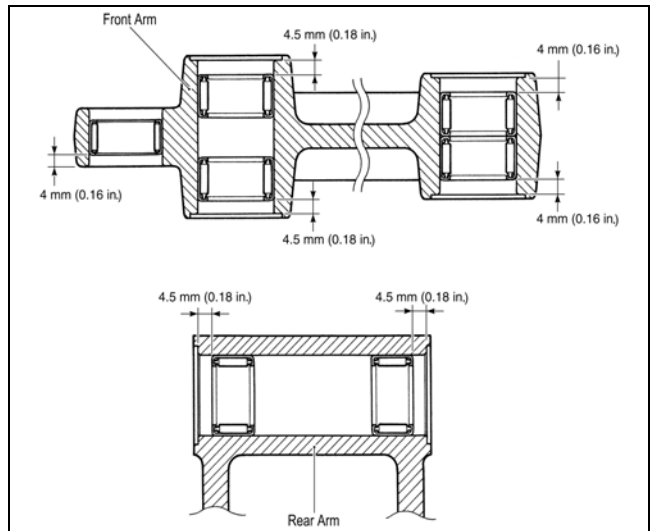

ATV2195

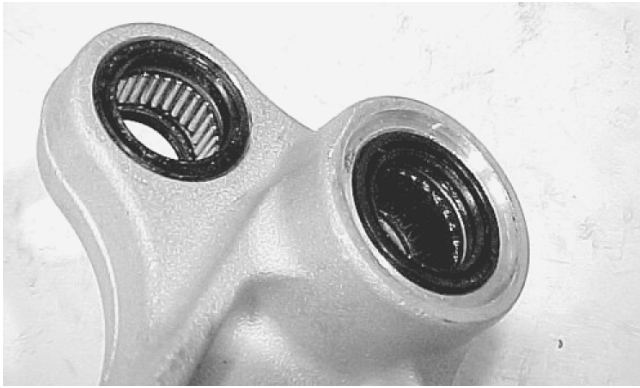

SP361

■NOTE: The stamped mark of the dust seals must be directed toward the outside of the assemblies.

5. Install the swing arm and pivot shaft; then install the swing-arm pivot nut and tighten to specifications.

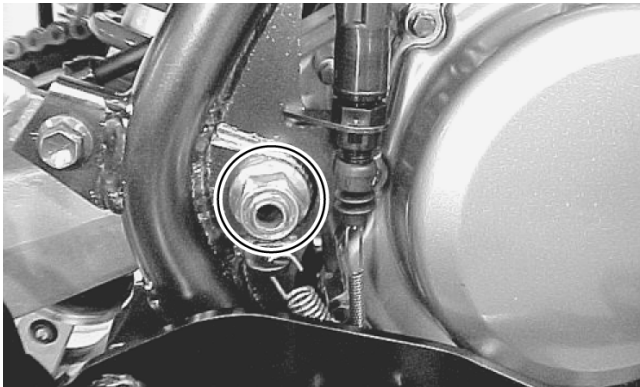

SP362

6. Install the rear shock absorber and front arm; then tighten the shock absorber mounting nuts (1 and 2) to specifications.

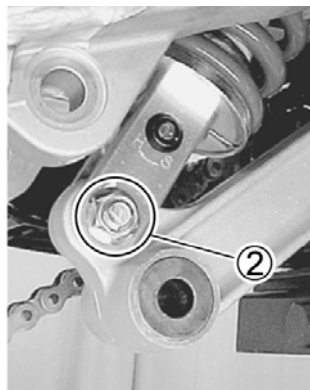
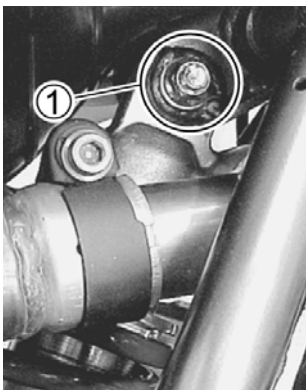

SP363A

7. Install the rear arm bolts and nuts; then tighten the nuts (3 and 4) to specifications.

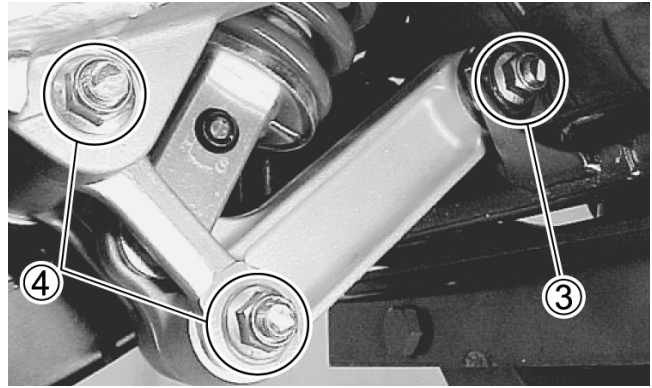

SP365

8. Install the rear arm guard and the swing-arm guard.

Front A-Arms

REMOVING

1. Secure the ATV on a support stand to elevate the front wheels; then remove a front wheel.

⚠ WARNING

Make sure the ATV is solidly supported on the support stand to avoid injury.

2. Remove the cotter pin from the nut.

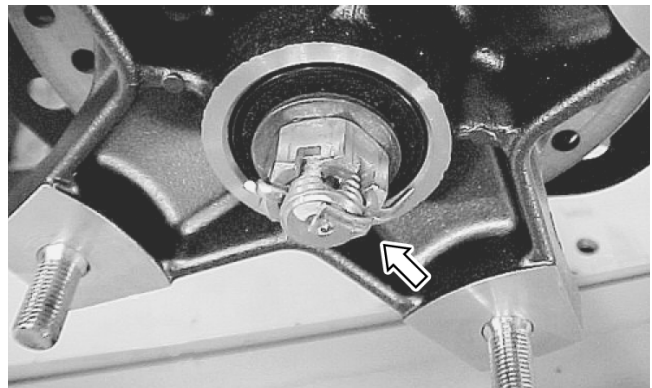

SP366

3. Remove the nut securing the hub. Account for a washer.
4. Remove the Allen-head screws (1) securing the brake caliper; then remove the caliper and lay aside.

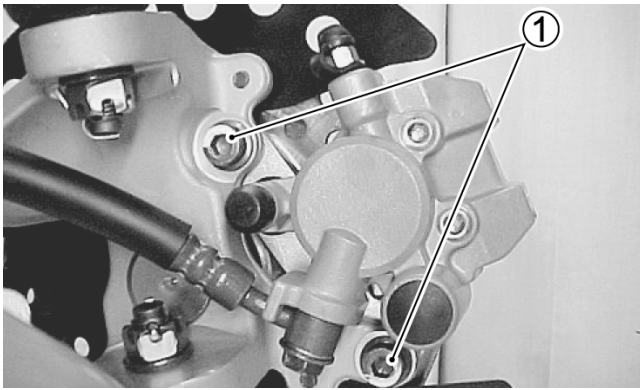

5. Remove the hub assembly; then remove the disc cover (2).

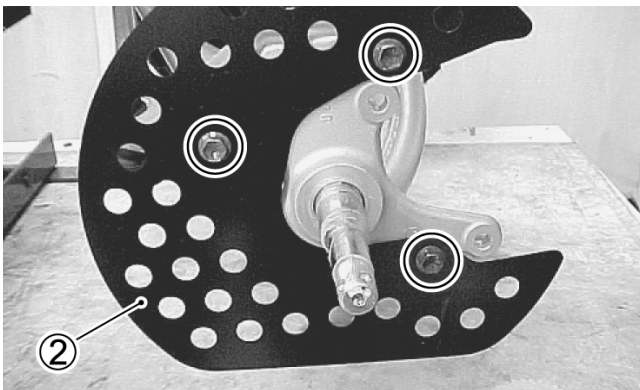

6. Remove the cotter pin and slotted nut securing the tie rod end to the knuckle; then remove the tie rod end from the knuckle.

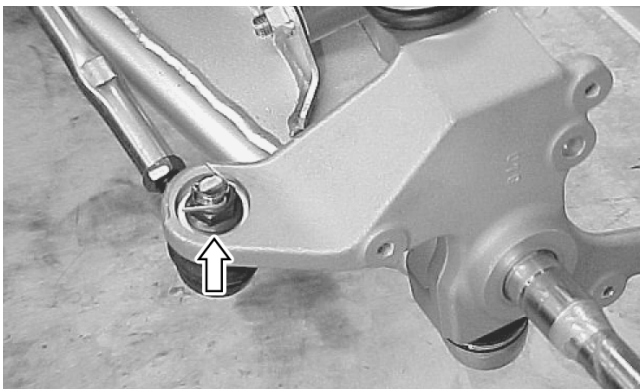

7. Remove the brake hose clamp (1) and release the hose from the clamp; then remove the front bumper assembly (3).

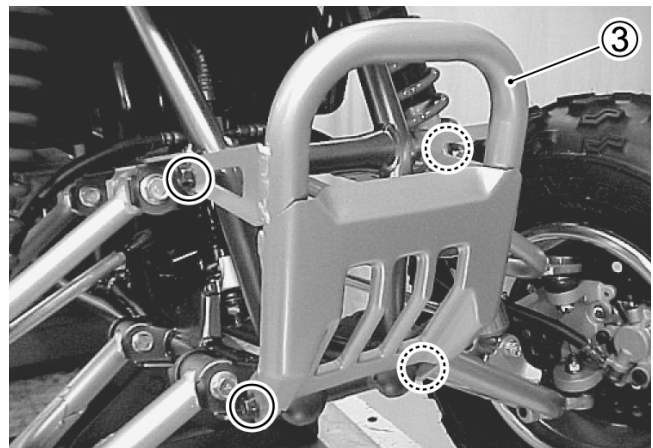
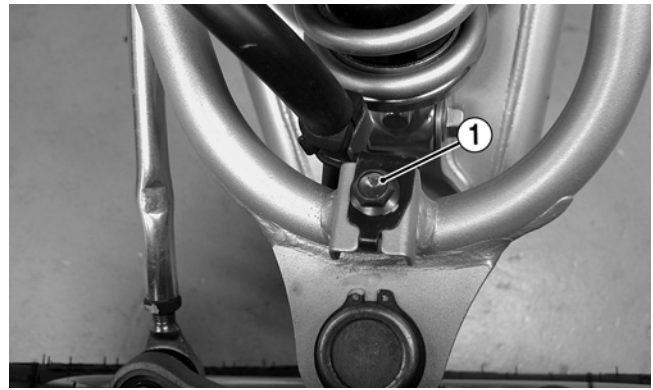

8. Remove the shock absorber lower mounting cap screw (4); then remove the arm assembly (5).

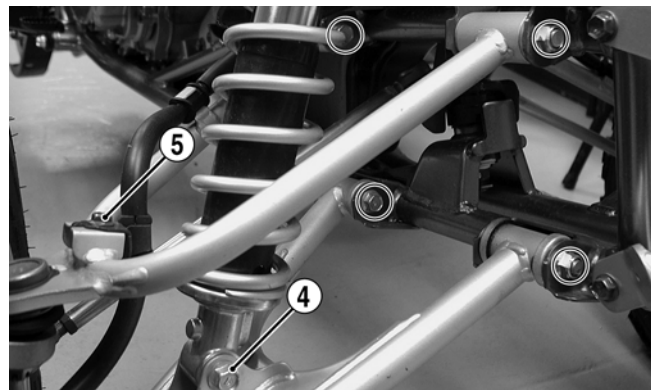

9. Remove the shock absorber; then remove the cotter pins and nuts from the ball joints.

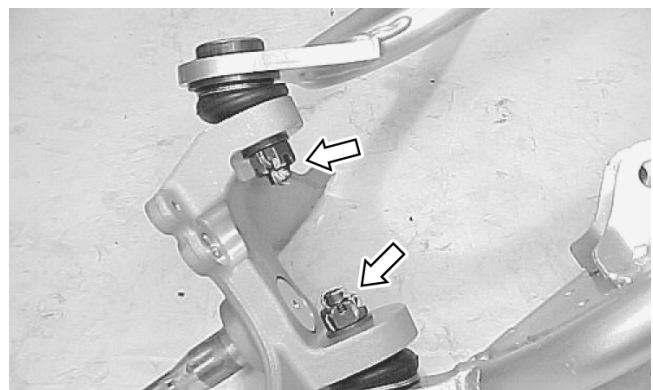

10. Using a ball joint remover (8), remove the ball joint from the knuckle (7).

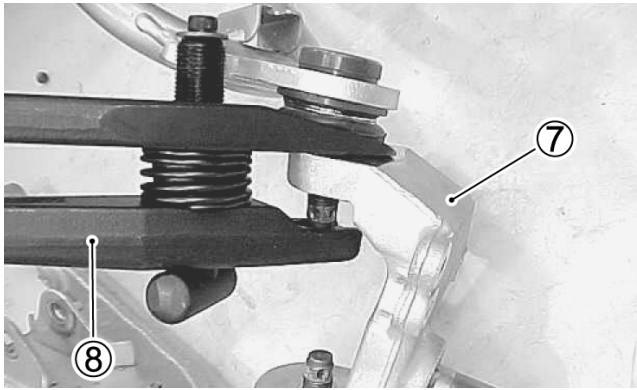

SP374

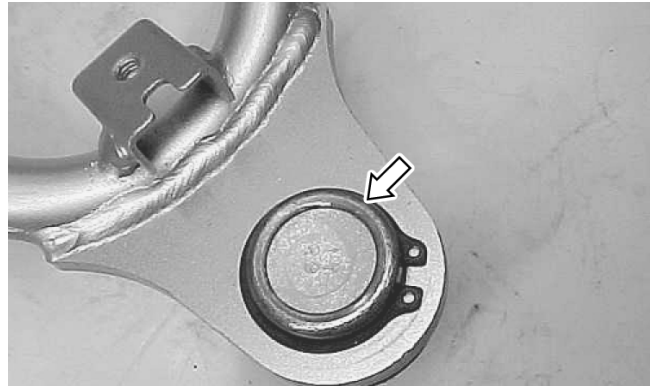

SP377

CLEANING AND INSPECTING

1. Clean the knuckle in parts-cleaning solvent; then dry with compressed air. If any damage or excessive wear is detected, the knuckle must be replaced.



SP375

2. Inspect the ball joint for boot damage or wear. Remove the circlip and replace the ball joint if damage is found.



SP376

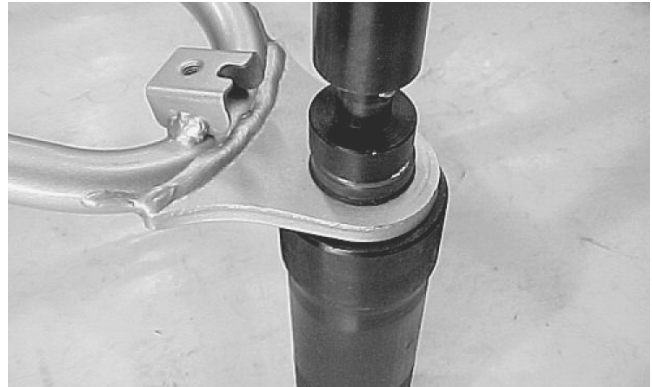

SP378

3. Inspect the arm for broken welds, cracks, or bends. Replace if damaged.



SP379

4. Remove the spacers and dust seals and inspect for damage to seal lips and spacers.

■NOTE: The pivots are equipped with roller bearings. The bearing rollers may fall out when the spacers are removed.

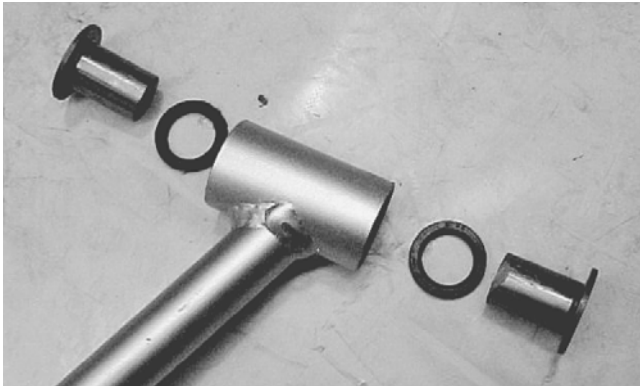

SP380

5. Check the bearings for excessive wear and replace them if worn.



SP381

6. Using a suitable bearing remover, remove the pivot bearings; then clean all parts in parts-cleaning solvent.

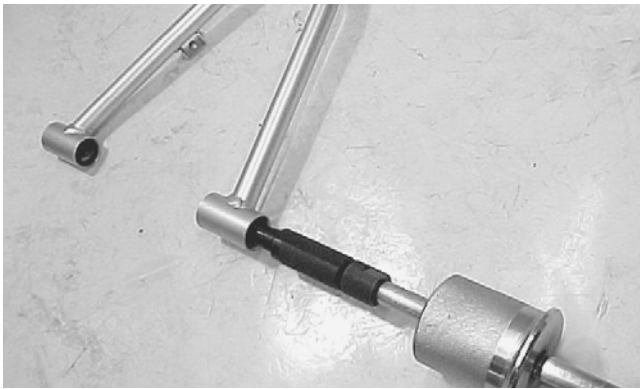

SP382

■NOTE: All bearings, spacers, and seals that are removed must be replaced with new ones.

INSTALLING

1. Using a bearing installer, install the ball joint in the arm; then install the circlip.

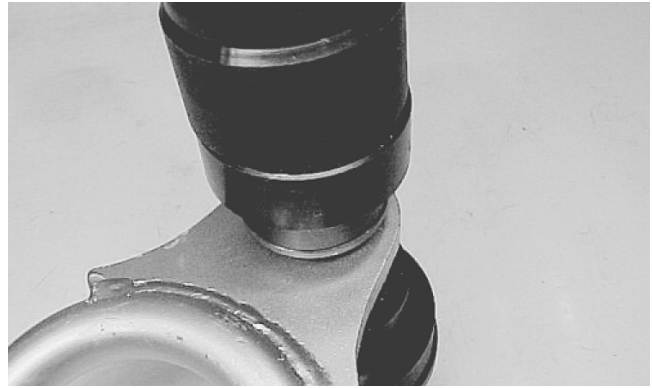

SP383

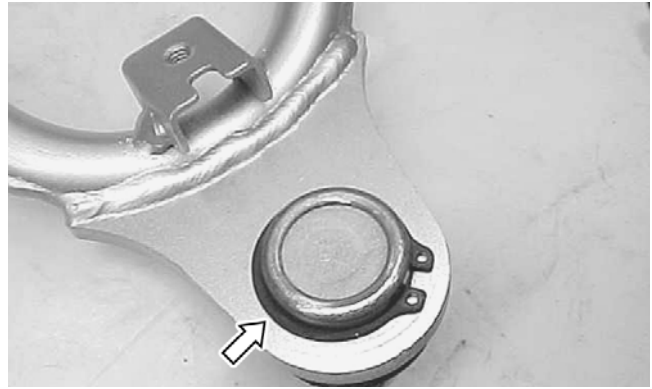

SP384

2. Install the bearings in the upper arm pivot to a depth of 12 mm (0.47 in.) with a bearing installer and suitable spacer. The stamped side of the bearing should be directed toward the spacer (1).

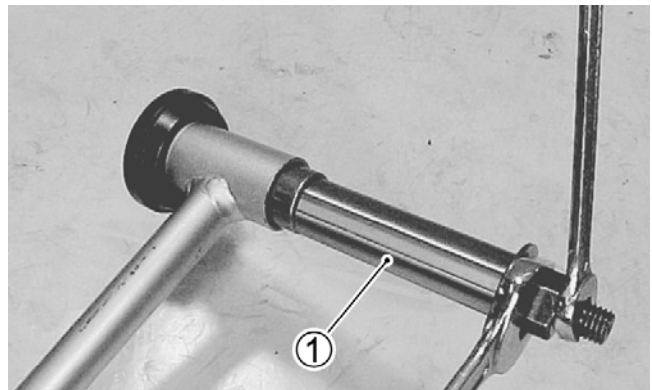

SP385

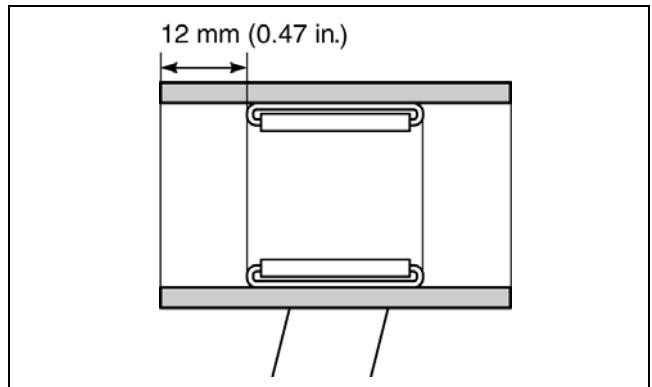

ATV2196

3. Coat the spacers (2) and the lips of the dust seals (3) with multipurpose grease; then install them in the upper pivot.

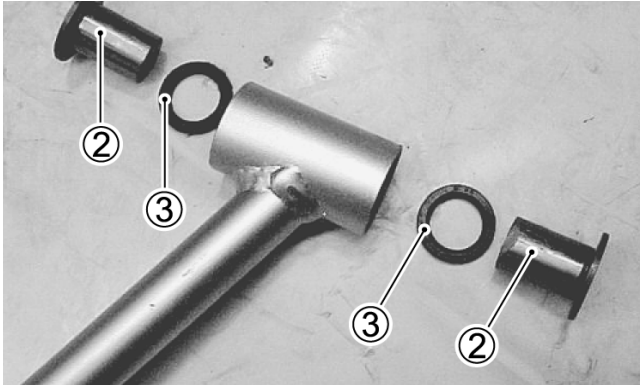

SP386

4. Install the bearing spacer (4), dust seals (5), dust covers (6), and washers (7) into the lower arm.

■NOTE: The stamped mark on the dust seals must be directed to the outside.

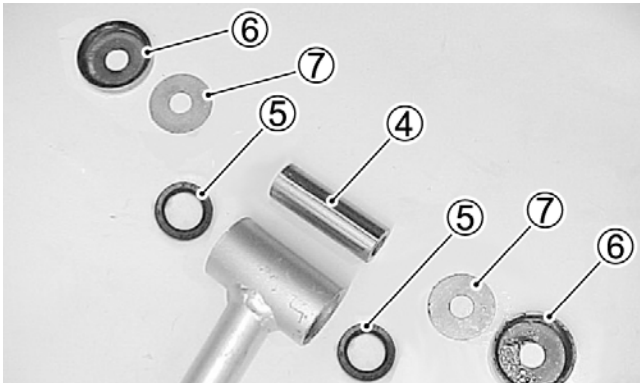

SP387

5. Clean all grease from the ball joint tapers and the knuckle bores; then install the arms to the steering knuckle and tighten the ball joint nuts to specifications. Install new cotter pins.

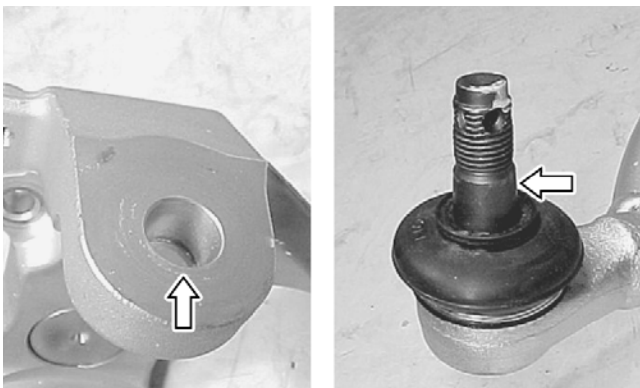

SP388A

■NOTE: During assembly, new cotter pins should be installed.

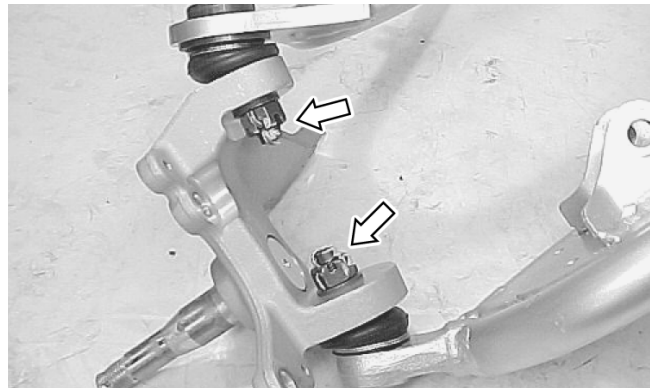

SP390

6. Install the arms to the frame with the pivot cap screws; then tighten the nuts to specifications (see Section 10).

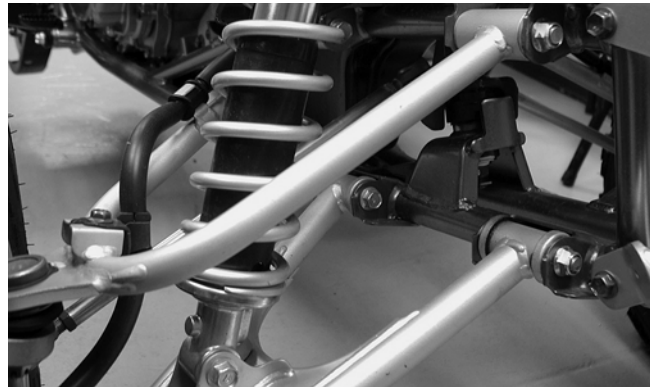

CD881

7. Install the front bumper assembly; then install the front shock absorbers. Use red Loctite #271 on the cap screw threads and tighten to specifications (see Section 10).

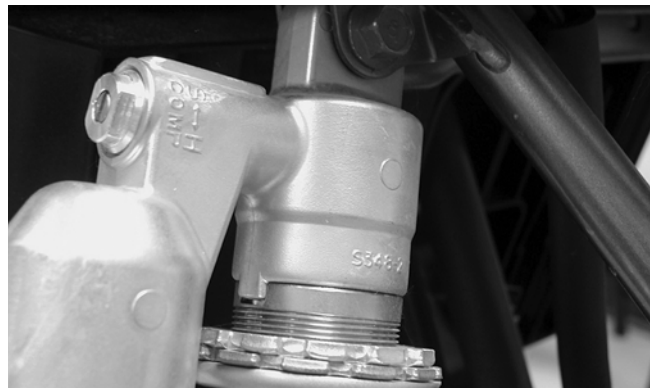

CD879

8. Apply red Loctite #271 to the mounting cap screws; then install the disc cover and tighten securely.

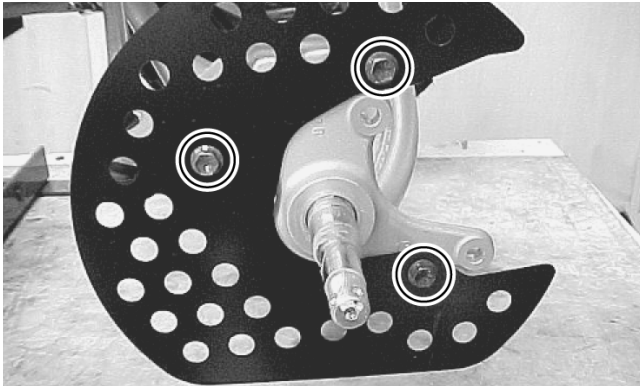

SP393

9. Connect the tie rod ends (11) to the steering knuckle (12) making sure that the washer (10) is properly located; then tighten the nut to specifications and install a new cotter pin.

■NOTE: During assembly, new cotter pins should be installed.

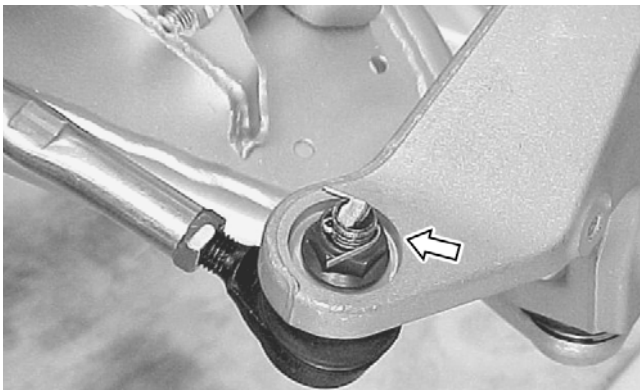

SP394

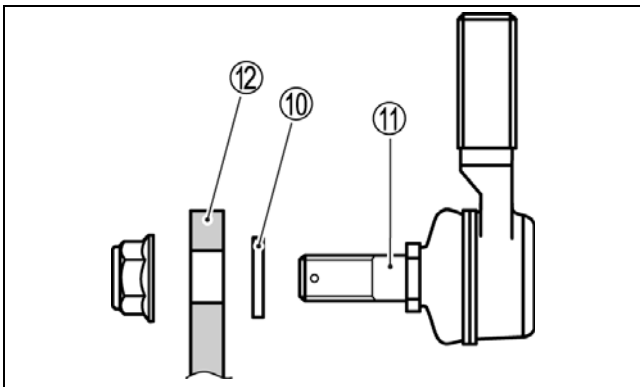

ATV2197

Wheels and Tires

TIRE SIZE

⚠ WARNING

Use only Arctic Cat approved tires when replacing tires. Failure to do so could result in unstable ATV operation.

The ATV is equipped with low-pressure tubeless tires of the size and type listed in Section 1. Do not under any circumstances substitute tires of a different type or size.

⚠ WARNING

Do not mix tire tread patterns. Use the same pattern type on front and rear. Failure to heed warning could cause poor handling qualities of the ATV and could cause excessive drive train damage not covered by warranty.

TIRE INFLATION PRESSURE

Tire inflation pressure should be 0.30 kg/cm² (4.4 psi) front and 0.275 kg/cm² (4.0 psi) rear.

REMOVING

1. Secure the ATV on a support stand to elevate the wheels.

⚠ WARNING

Make sure the ATV is solidly supported on the support stand to avoid injury.

2. Remove the wheels.

■NOTE: Keep left-side and right-side wheels separated for installing them on their proper sides.

CLEANING AND INSPECTING

■NOTE: Whenever a part is worn excessively, cracked, or damaged in any way, replacement is necessary.

1. Clean the wheels and hubs with parts-cleaning solvent.
2. Clean the tires with soap and water.
3. Inspect each wheel for cracks, dents, or bends.
4. Inspect each tire for cuts, wear, missing lugs, and leaks.

INSTALLING

1. Install each wheel on its hub.

■NOTE: Make sure each wheel is installed on its proper hub as noted in removing (the “rotation arrow” must indicate forward direction of rotation).



AF612D

2. Tighten to specifications (see Section 10).

CHECKING/INFLATING

1. Using an air pressure gauge, measure the air pressure in each tire. Adjust the air pressure as necessary to meet the recommended inflation pressure.
2. Inspect the tires for damage, wear, or punctures.

WARNING

Do not operate the ATV if tire damage exists.

■NOTE: If repair is needed, follow the instructions found on the tire repair kit or remove the wheel and have it repaired professionally.

■NOTE: Be sure all tires are the specified size and have identical tread pattern.

3. Check the front wheel toe-in and toe-out and adjust as necessary (see Section 8).
4. Test drive the ATV on a dry, level surface and note any pulling to the left or right during acceleration, deceleration, and braking.

■NOTE: If pulling is noted, measure the circumference of the front and rear tires on the pulling side. Compare the measurements with the tires on the opposite side. If pulling is noted during braking only, check and adjust the brakes as necessary and recheck operation (see Section 2).

5. Increase the air pressure in the tires with the smallest circumference measurement until all tires are equal in circumference.
6. Repeat steps 4-5 as necessary to ensure proper handling.

SECTION 8 - STEERING/FRAME

TABLE OF CONTENTS

Steering Post/Tie Rods	8-2
Measuring/Adjusting Toe-In/Toe-Out.....	8-7
Body	8-7

Steering Post/Tie Rods

■NOTE: Critical torque specifications are located in Section 10.

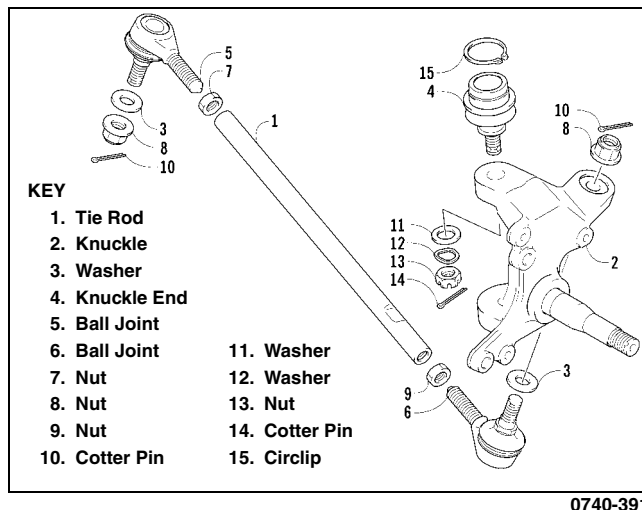
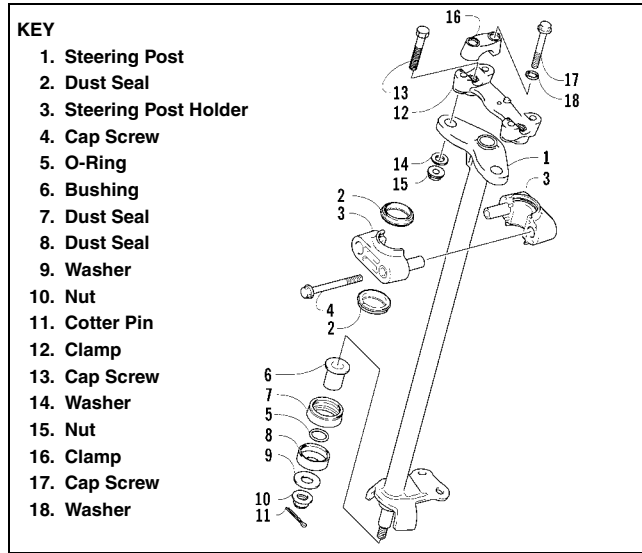

REMOVING

1. Remove the seat, gas tank panel, and body (see Body in this section); then remove the brake master cylinder assembly (1).
2. Remove the throttle lever case (2).

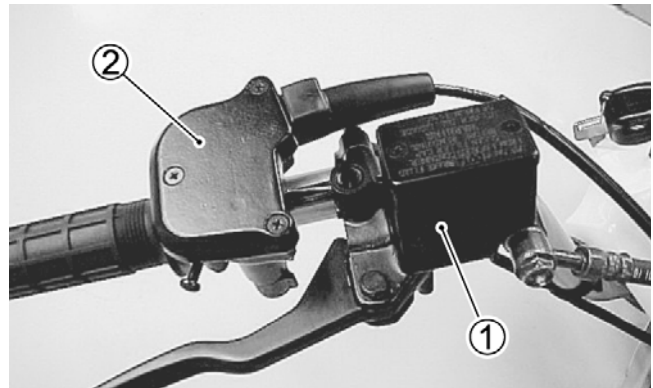

3. Disconnect the parking brake cable (3) and clutch lever cable (4); then remove the clutch position switch (5) with the parking brake engagement pin (A) depressed. Remove the handlebar switch assembly (6).

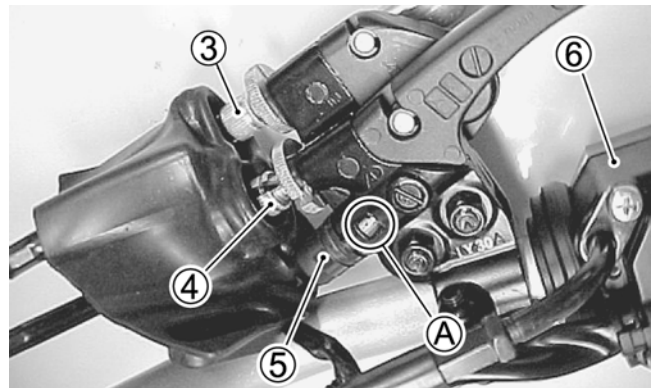

4. Remove the steering head cover (7); then remove the harness clamps (8).

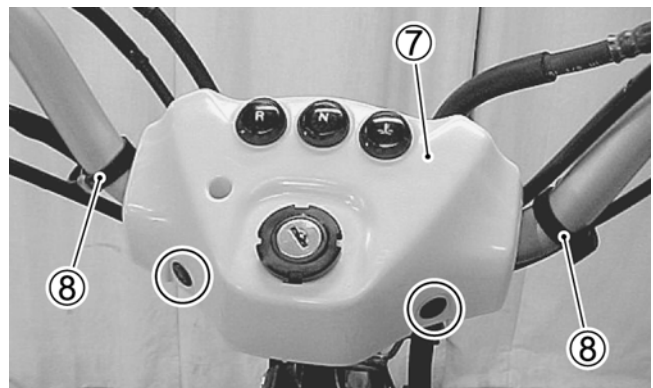

5. Remove the handlebar (9); then remove the steering head cover bracket (10).

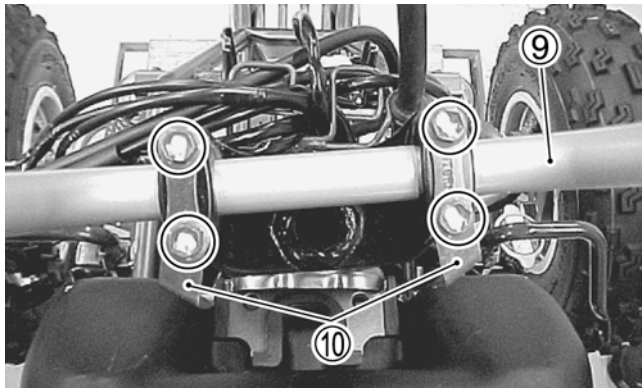

SP398

6. Drain the engine oil from the oil tank; then drain the coolant from the radiator.

7. Remove the radiator assembly (1) (see Section 4).

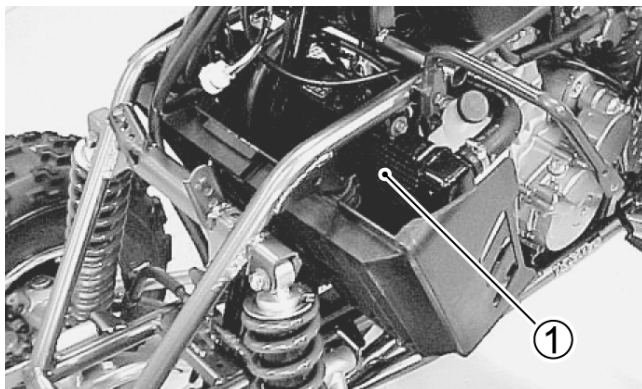

SP399

8. Remove the two fasteners; then remove the oil hose protector.

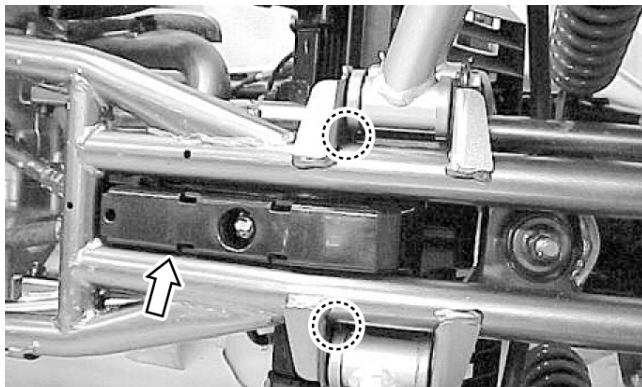

SP400

9. Disconnect the oil hoses (2) and the breather hose (3); then remove the oil tank (4).

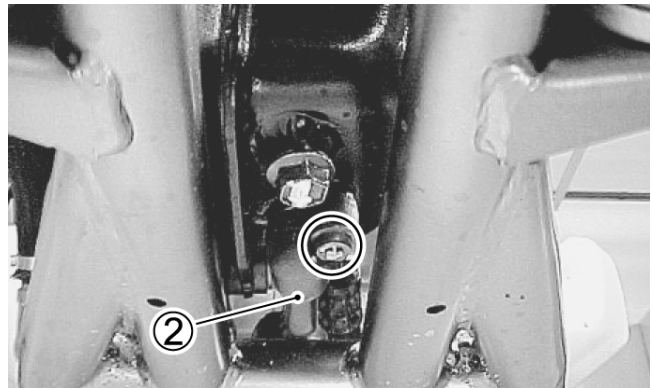

SP401

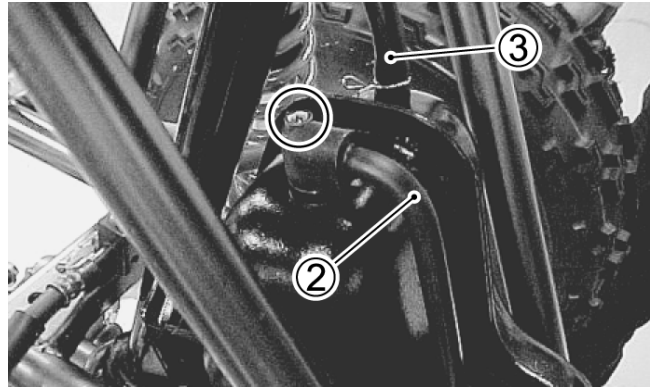

SP402

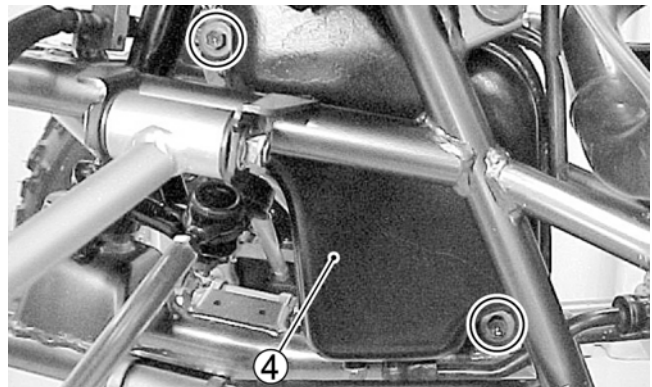

SP403

10. Remove the cotter pins and tie rod end nuts; then remove the tie rods.

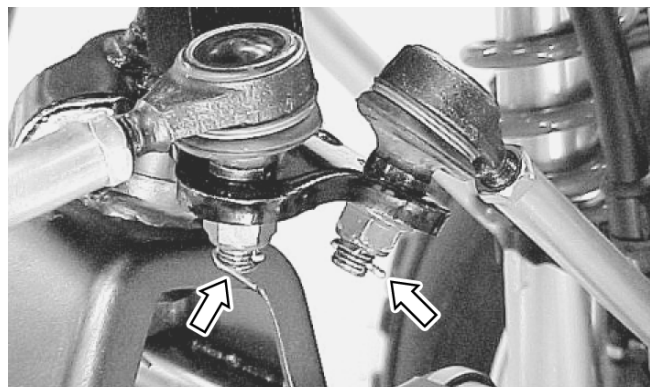

SP404

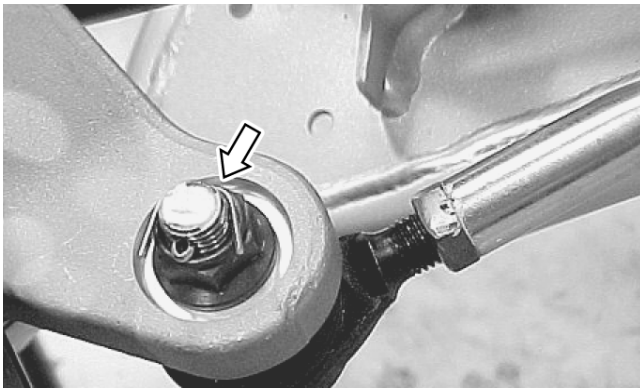

SP405

11. Remove the cotter pin, steering post nut (5), washer (6), and dust seal (7) accounting for the O-ring (8); then remove the steering post holder cap screws.

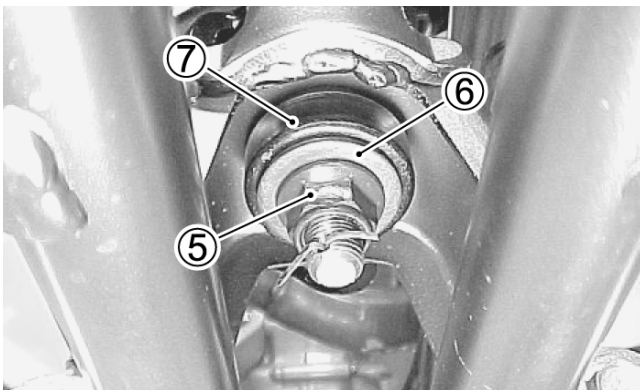

SP406

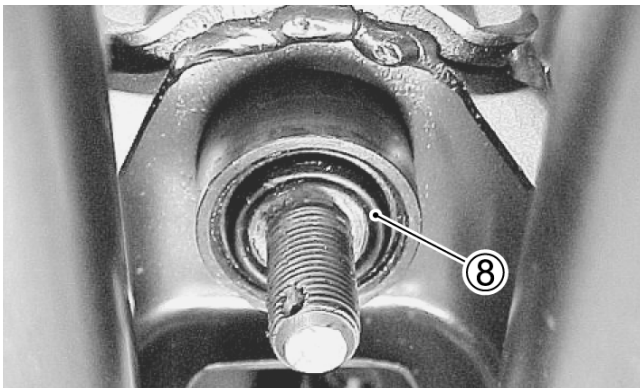

SP407

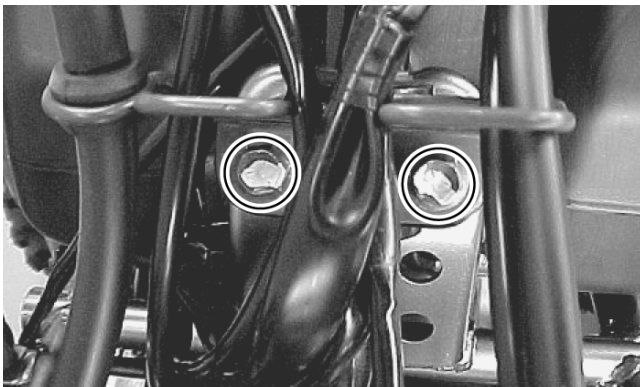

SP408

12. Remove the hose and cable guide; then remove the steering post holder

13. Remove the steering post (9); then remove the dust seals (10), and the steering post holder half (11).

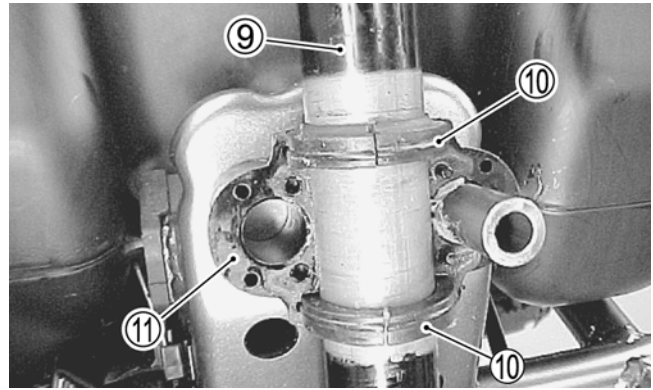

SP409

14. Remove the dust seals (12) from the steering post; then clean all removed parts in parts-cleaning solvent.

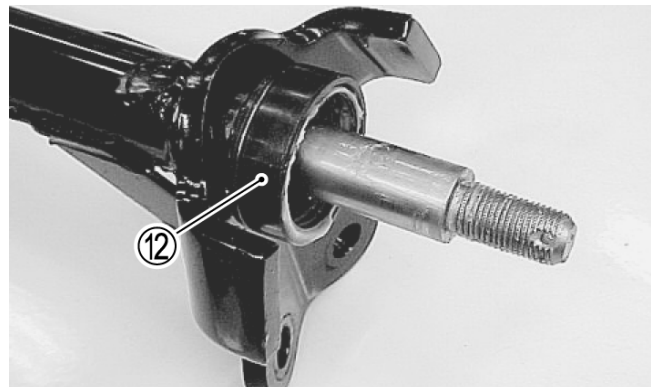

SP410

CLEANING AND INSPECTING

■ **NOTE:** Whenever a part is worn excessively, cracked, or damaged in any way, replacement is necessary.

1. Wash the tie rod ends in parts-cleaning solvent. Dry with compressed air. Inspect the pivot area for wear. Apply a low-temperature grease to the ends.

WARNING

Always wear safety glasses when using compressed air.

2. Inspect the tie rods for damaged threads or wear.
3. Inspect the tie rods for cracks or unusual bends.
4. Inspect all welded areas for cracks or deterioration.
5. Inspect the steering post and steering-post holders for cracks, bends, or wear.
6. Inspect the handlebar clamps for cracks or wear.
7. Inspect the handlebar for cracks, wear, or unusual bends.

8. Inspect the handlebar grips for damage or wear.

INSTALLING

1. Apply multipurpose grease to the steering post and dust seal; then install the dust seal (1) to the steering post.

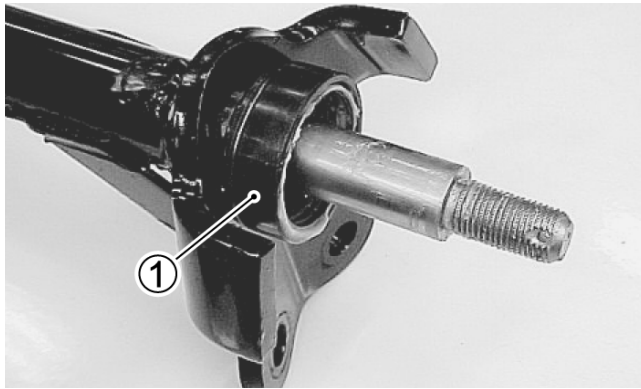

SP411

2. Install a new O-ring (2) and the dust seal into the steering housing; then install the washer and nut and tighten to specifications. Install a new cotter pin.

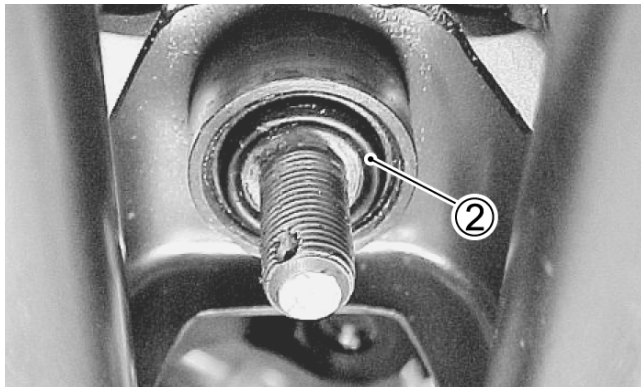

SP412

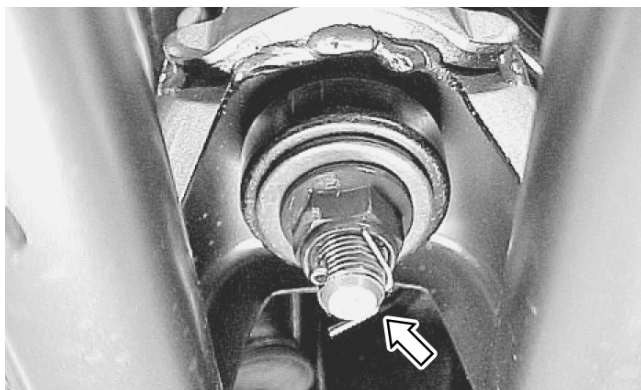

SP413

3. Apply multipurpose grease to the dust seal lips (A) and sliding surface of the steering post holders; then secure the holders with cap screws and tighten to specifications.

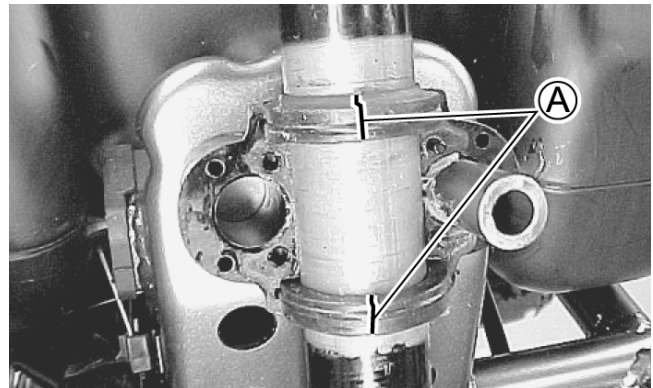

SP414

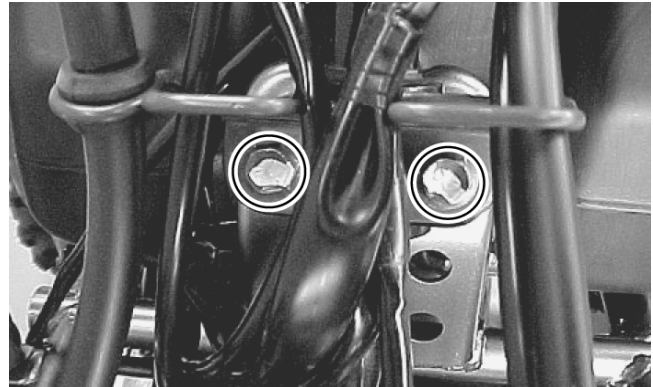

SP415

■ **NOTE:** Ensure that all wiring is properly routed and the brake hoses and control cables are not kinked or bound.

4. Install the tie rods to the steering post and knuckles; then tighten the nuts to specifications and install new cotter pins.

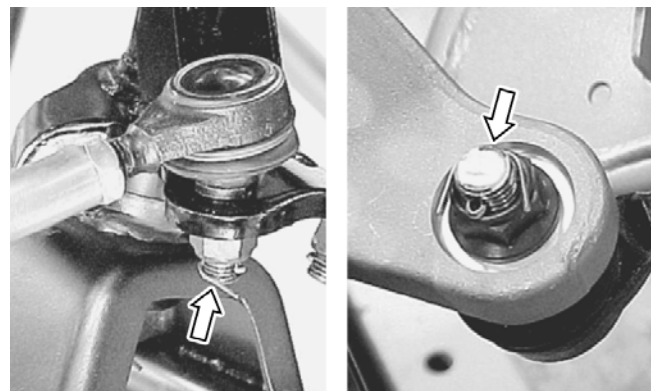

SP416A

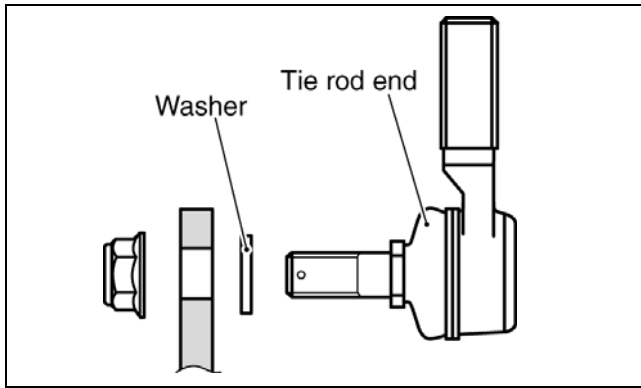

ATV2200

■NOTE: When installing the tie rod, the shorter end of the tie rod (1) should be directed toward the steering knuckles. The yellow surfaced nuts (2) are left-hand threads.

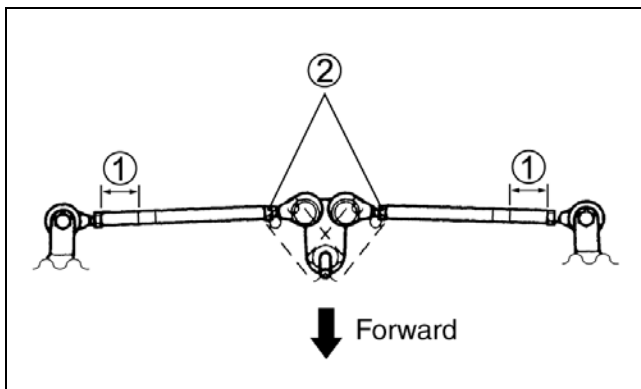

ATV2201

5. Install the oil tank (see Section 4).
6. Install the radiator assembly (see Section 4).
7. Fill with oil and coolant; then bleed the cooling system (see Section 2).
8. Assemble the handlebar (1), handlebar holder (2), and steering head cover bracket (3) with the stepped end of the lower holder (A) directed rearward; then finger-tighten the cap screws.

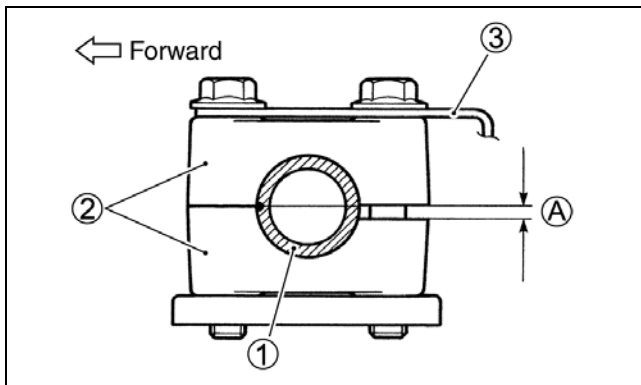

ATV2202

9. Adjust the handlebar in the holders to align the punch mark (B) with the mating surface of the handlebar holders. Tighten first the forward cap screws (4) to specifications; then tighten the rearward cap screws (5) to specifications.

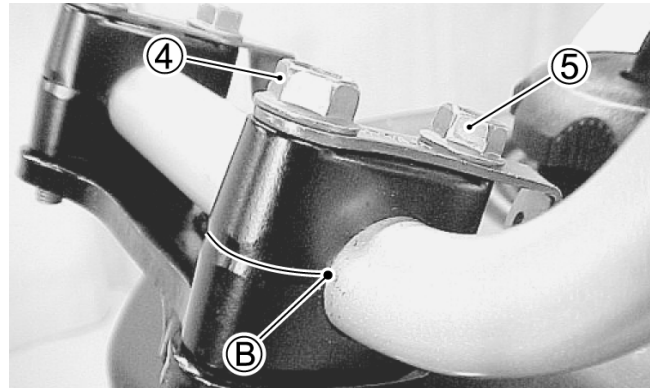

SP418

10. Install the steering head cover (6).

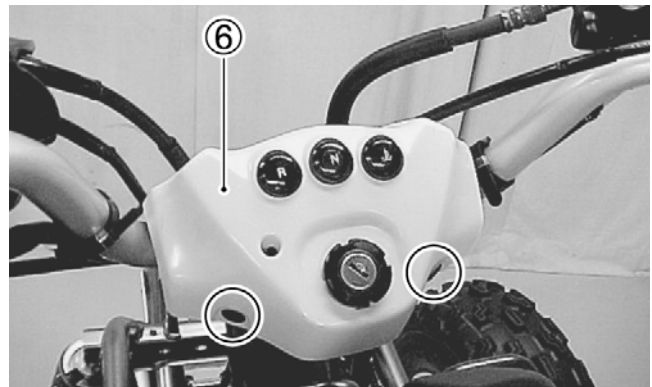

SP419

11. Install the handlebar switch assembly engaging the locator lug (C) into the hole (D) in the handlebar.

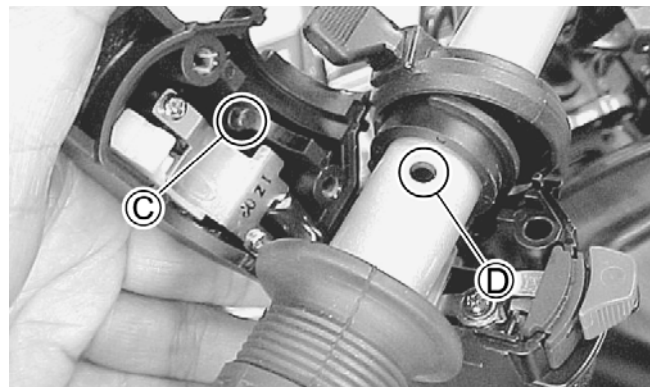

SP420

12. Install the clutch lever assembly to the handlebar aligning the clutch lever holder mating surface with the punch mark on the handlebar; then connect and adjust the clutch lever cable and the clutch switch. For adjustment, see Section 2.

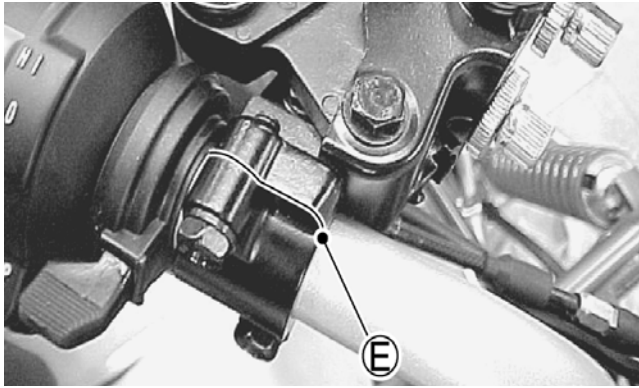

SP421

13. Install the throttle lever case to the handlebar aligning the housing mating surface with the punch mark (F); then tighten the throttle case screws securely.

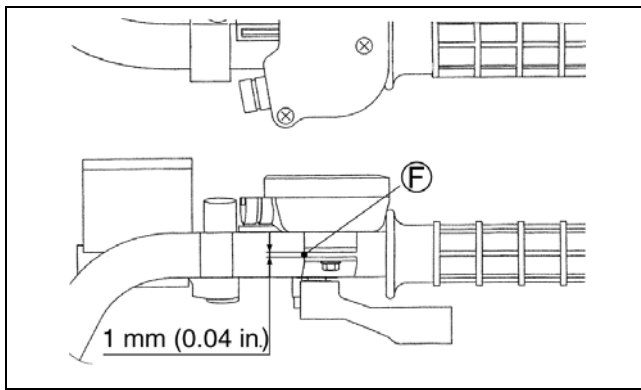

ATV2203

14. Install the brake master cylinder and check for proper fluid level (see Section 2).

Measuring/Adjusting Toe-In/Toe-Out

1. With the ATV on a level surface, center the handlebar for straight ahead using a suitable means of measuring centering; then adjust tire pressure to specifications.
2. Place suitable ballast of 75 kg (165 lb) of weight on the seat; then loosen the lock nuts (1 and 2) on each tie rod.

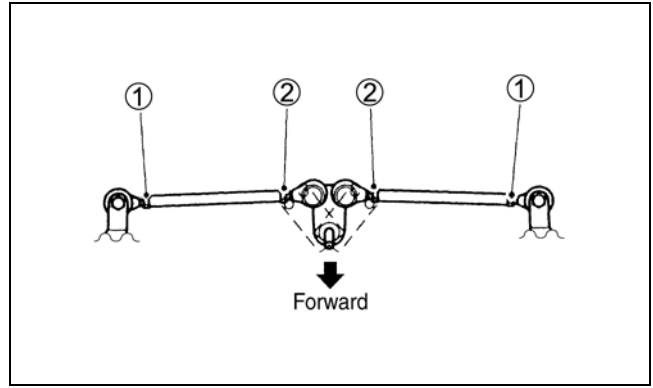

ATV2204

3. Measure the distance (A) and (B) between the front wheels; then subtract distance (B) from (A). Distance A - Distance B = Toe-In.

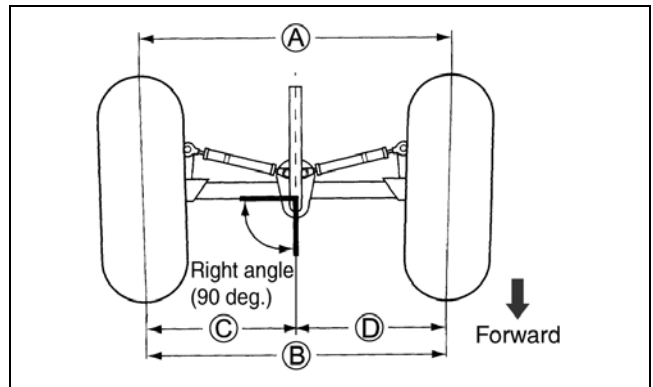

ATV2205

4. Adjust toe-in to 5 mm (0.20 in.); then measure distances (C) and (D). Distances (C) and (D) should be equal.
5. After all the adjustments are to specifications, tighten the tie-rod lock nuts to specifications (see Section 10).

■NOTE: Prior to locking the jam nuts, make sure the ball joints are at the center of their normal range of motion and at the correct angle.

■NOTE: The front wheels do not have to be removed to adjust the tie rod. Also, care should be taken not to disturb the handlebar position.

Body

REMOVING

1. Remove the seat; then remove the battery hold-down, battery, and starter relay. Lay the relay aside without disconnecting the wiring.



SP107

■NOTE: Always remove the negative battery cable first; then the positive. Install the positive cable first; then the negative.

2. Remove the two forward underseat screws; then remove the rear fender support mounting nuts.



SP098

3. Remove the front fender support brackets from the frame leaving them attached to the body.

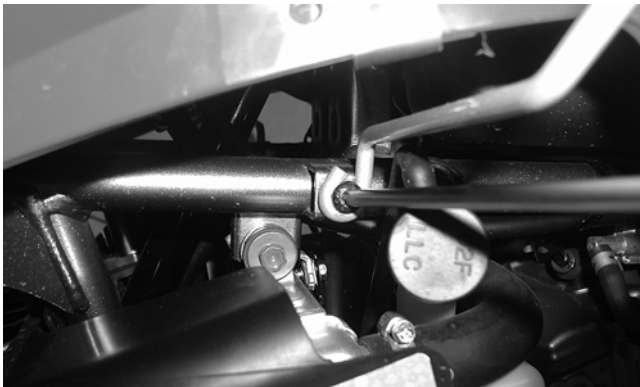

SP099

4. Remove the two nuts from the plastic studs on the upper forward support bracket.

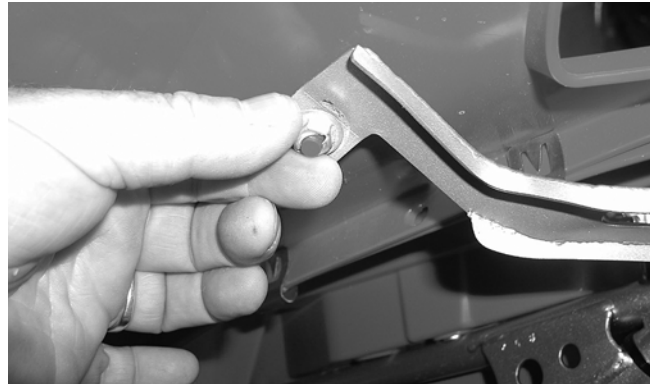

SP100

5. Remove the screw securing the front lip of the body to the headlight housing.



SP102

6. Pull rearward on the gas tank cover and dislodge the two barbed fasteners; then remove the gas tank cap.

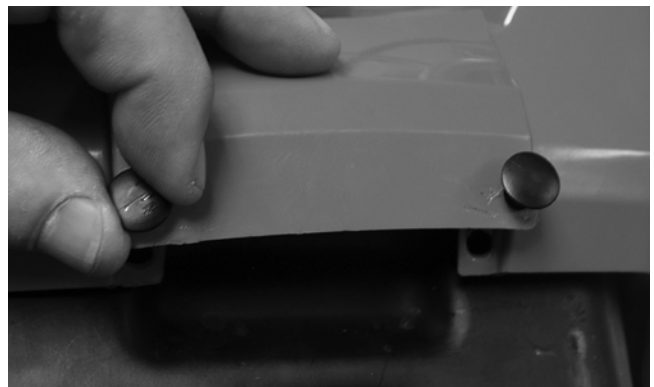

SP101

7. Lift up the rear of the gas tank cover and push forward to disengage the "L" tabs; then lift the gas tank cover off. Install the gas tank cap.

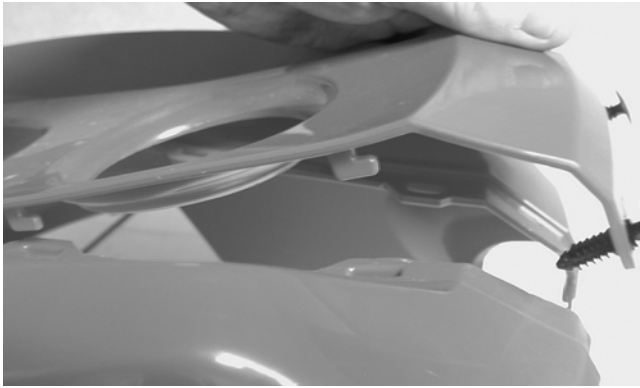

SP105

8. Lift the body clear of all brackets and studs; then rotate clockwise and work handlebar through the center body openings.

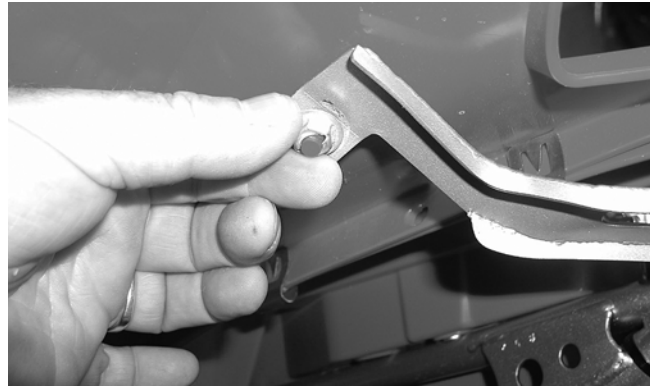

SP100

3. Install the front lip screw into the headlight housing; then install the screws securing the front fender supports to the frame.



SP104

9. Set body and tank panel to the side in a safe place.

CLEANING AND INSPECTING

■NOTE: Whenever a part is worn excessively, cracked, or damaged in any way, replacement is necessary.

1. Clean all body components with soap and water.
2. Inspect the body and fenders for cracks.
3. Inspect threaded areas of all mounting studs for stripping.
4. Inspect for missing decals.

INSTALLING

1. Fit the body over the handlebar and rotate into normal mounting position.
2. Seat the two upper forward support studs and the rear fender support studs into the brackets; then install the nuts and tighten securely. Take care not to over-tighten.



SP102

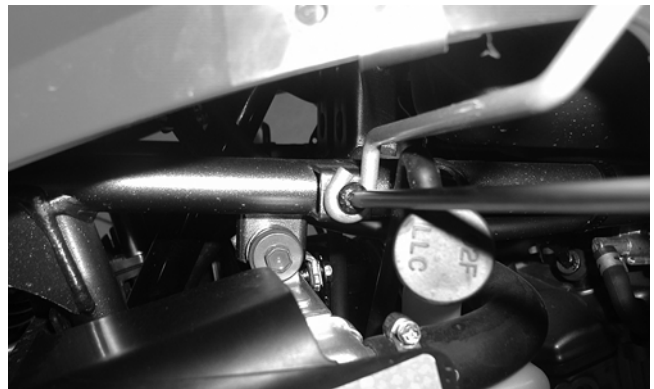

SP099

4. Install the forward underseat fasteners and tighten the screws only until snug.
5. Install the battery connecting first the positive cable; then the negative cable.
6. Install the battery hold-down correctly noting that the front and rear are different; then secure with the two hold-down screws which are also through-body mount screws.



SP106



SP107

7. Install the starter relay; then install the seat making sure it is locked securely front and rear.

SECTION 9 - CONTROLS/INDICATORS

TABLE OF CONTENTS

Front Brake Lever/Master Cylinder Assembly	9-2
Rear Brake Pedal/Master Cylinder Assembly	9-3
Throttle Control	9-5
Reverse Selector/Lock	9-6

Front Brake Lever/ Master Cylinder Assembly

■NOTE: The master cylinder is a non-serviceable component; it must be replaced as an assembly.

REMOVING

1. Place a shop towel under the brake hose union bolt and disconnect the brake hose.

⚠ CAUTION

Brake fluid is highly corrosive. Do not spill brake fluid on any surface of the ATV.

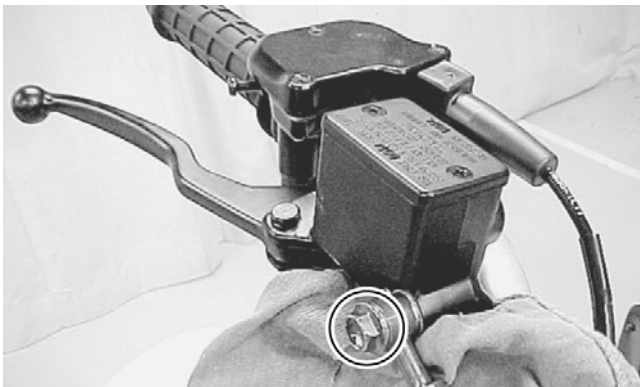

SP422

2. Remove the master cylinder assembly; then remove the reservoir cap (3) and the diaphragm (4). Drain the brake fluid.

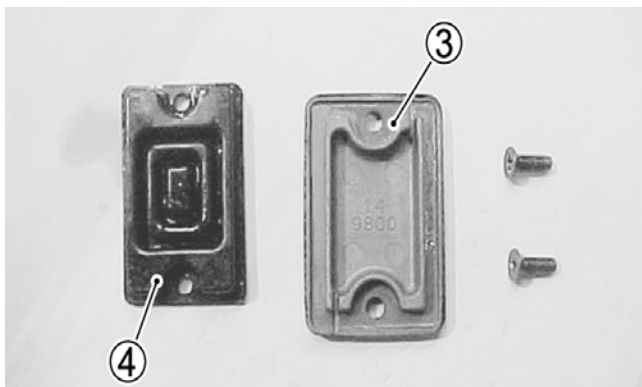

SP423

3. Remove the brake lever (1) and brakelight switch (2).

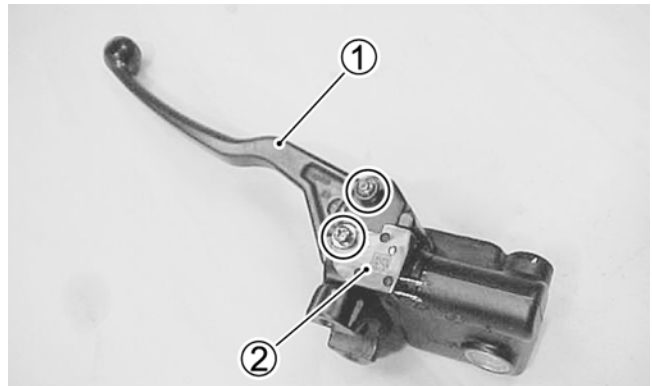

SP424

4. Pull the rubber boot (5) out; then remove the circlip (6).

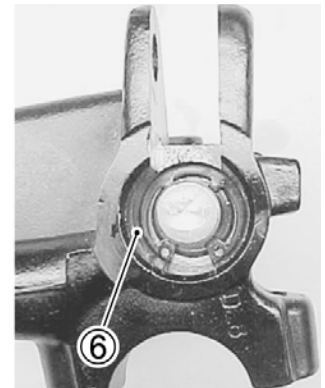
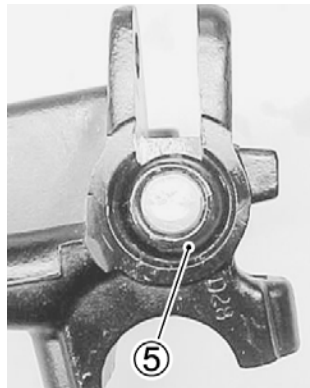

SP425A

5. Remove the piston (8), secondary cup (7), primary cup (9), and spring (10).

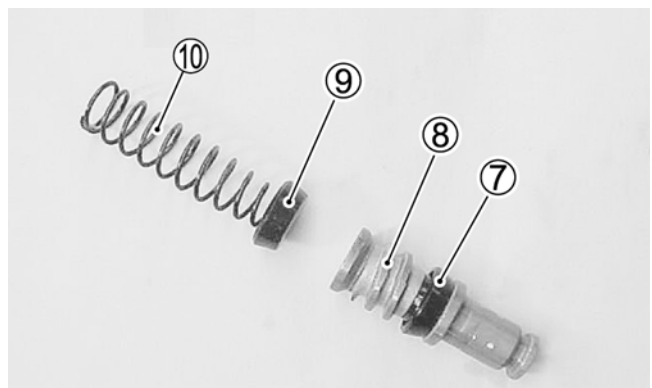

SP427

INSPECTING

■NOTE: Whenever a part is worn excessively, cracked, or damaged in any way, replacement is necessary.

1. Inspect the pivot bolt securing the brake lever for wear.
2. Inspect the brake lever for elongation of the pivot hole.
3. Inspect the reservoir for cracks and leakage.

4. Inspect the brake hose for cracks and deterioration and the condition of the fittings (threaded and compression).
5. Inspect the brakelight switch for corrosion, cracks, missing or broken mounting tabs, or broken and frayed wiring.

■NOTE: If the brakelight switch is determined to be not serviceable, see Section 5.

INSTALLING

■NOTE: Wash all master cylinder components in new brake fluid before assembling. Do not dry components.

1. Apply brake fluid to the master cylinder bore; then install the spring/primary cup and the piston/secondary cylinder into the master cylinder.
2. Install the circlip; then install the rubber boot.
3. Align the master cylinder mount (A) to the punch mark (B) on the handlebar (E); then install the clamp bolts (D).

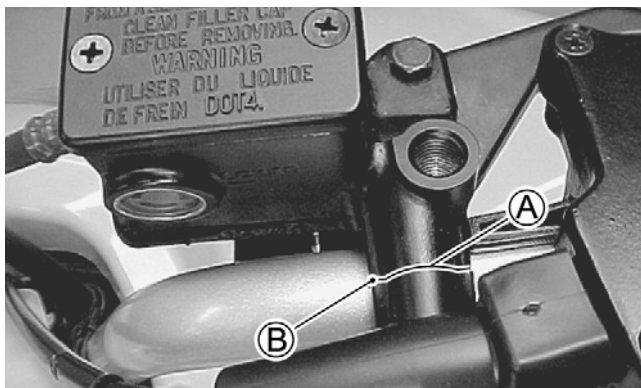

SP436

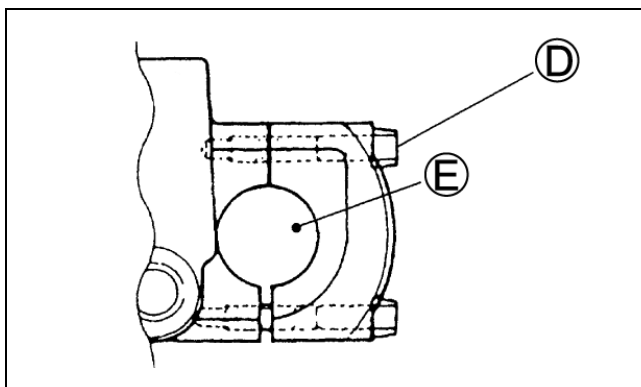

ATV2206

4. Beginning with the upper clamp bolt, tighten the mounting bolts to specifications (see Section 10).
5. Connect the brake hose union bolt (1) to the master cylinder; then with the stopper against the master cylinder, tighten the brake hose union bolt to specifications (see Section 10).

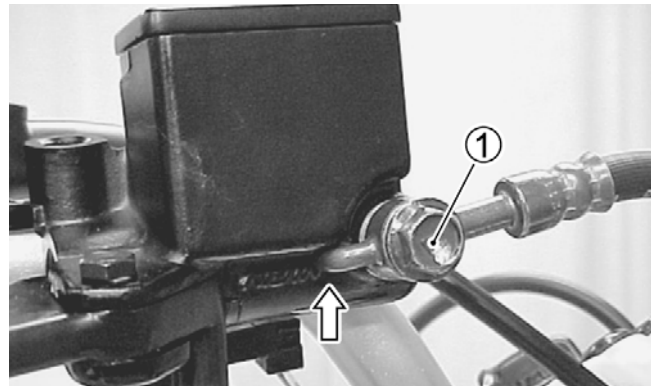

SP437

6. Fill the master cylinder with DOT 4 brake fluid; then bleed the system (see Section 2).

Rear Brake Pedal/ Master Cylinder Assembly

REMOVING

1. Connect a clear plastic hose to the bleeder screw on the rear brake caliper; then loosen the bleeder screw and pump the foot brake until the fluid is pumped into a suitable container.
2. Disconnect the brake hose (2) by removing the union bolt (1). Loosen the jam nut (3); then remove the mounting cap screws (4), turn the push rod (5) out of the connector, and remove the master cylinder.

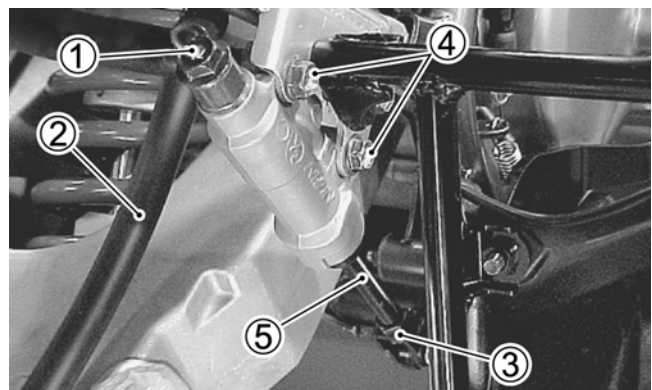

SP428

3. Compress the spring clamp and remove the reservoir hose (6).

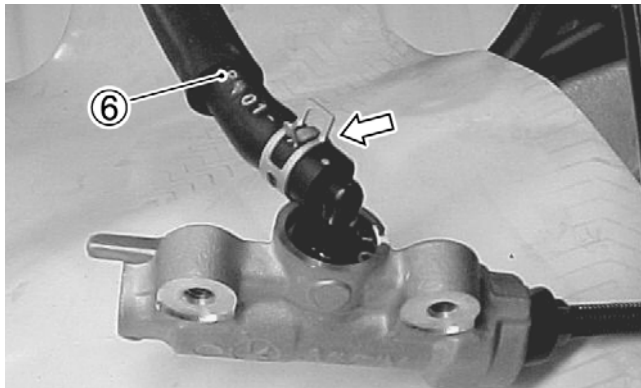

SP429

⚠ CAUTION

Brake fluid is highly corrosive. Do not spill brake fluid on any surface of the ATV.

4. Remove the circlip (9); then pull out the reservoir elbow fitting (7) and O-ring (8).

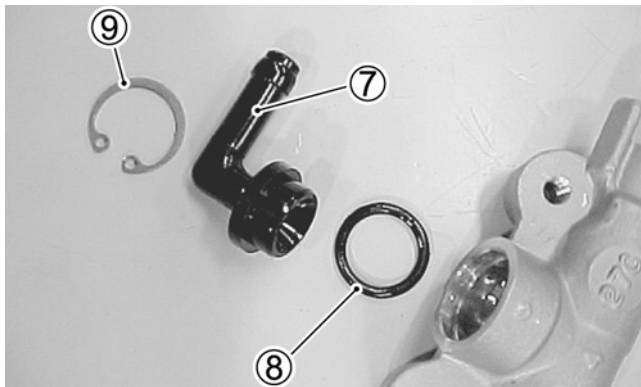

SP430

5. Remove the dust boot (10) and circlip (11); then remove the push rod (12), piston with cups (13), and spring (14).

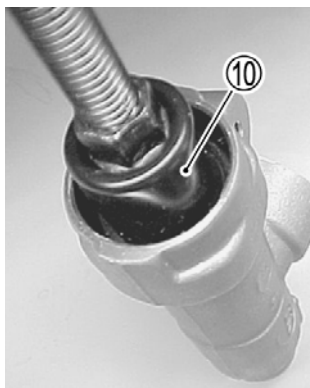

SP431A

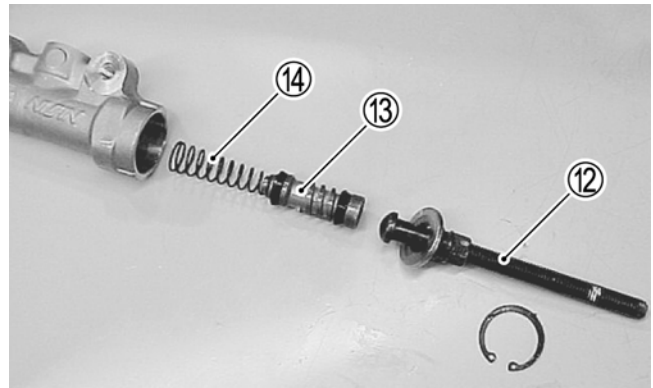

SP433

INSPECTING

1. Inspect the master cylinder bore for any scratches or damage.
2. Inspect the piston surface, primary cup, secondary cup, and boot for nicks, wear, or cracks.
3. Replace all damaged parts.

INSTALLING

NOTE: Wash all master cylinder components in new brake fluid before assembling. Do not dry components.

1. Apply brake fluid to the master cylinder bore; then install the piston with cups.
2. Install the push rod and secure with circlip; then coat the push rod with multipurpose grease.

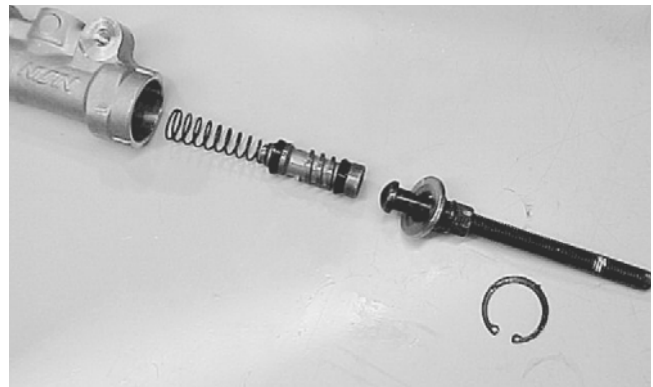

SP434

3. Install the O-ring; then place the reservoir elbow fitting into the master cylinder and secure with the circlip.
4. Tighten the master cylinder push rod lock nut (1), master cylinder mounting cap screws (2), and the brake hose union bolt (3) to specifications (see Section 10).

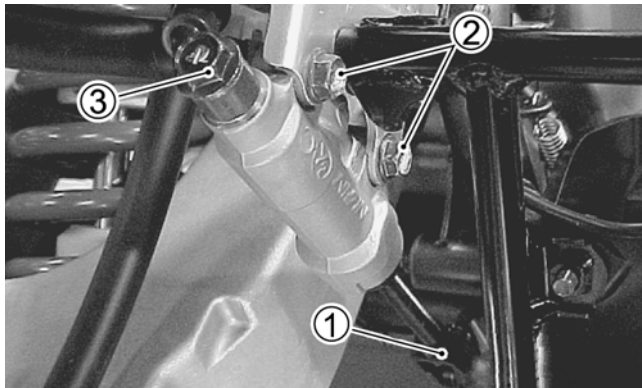

SP435

5. Install the reservoir tank hose; then fill the master cylinder reservoir with DOT 4 brake fluid and bleed the system (see Section 2).

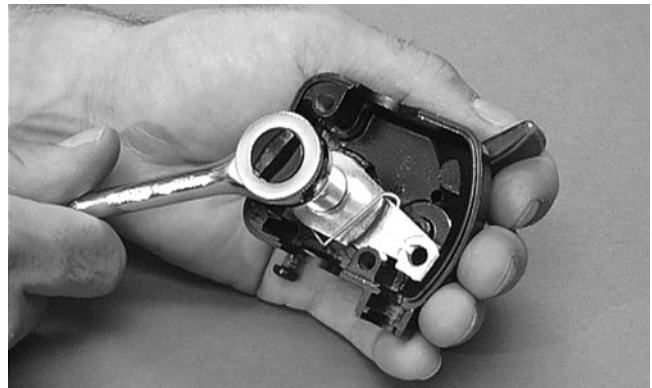

AF677D

4. Remove the actuator arm and account for a bushing. Note the position of the return spring for installing purposes.

Throttle Control

REMOVING

1. Remove the two machine screws securing the throttle control to the handlebar.

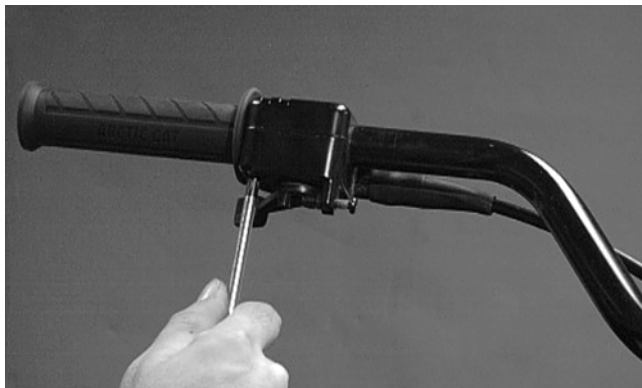

AL610D

2. Slide the grommet out of the lower half of the throttle control; then remove the cable from the actuator arm.

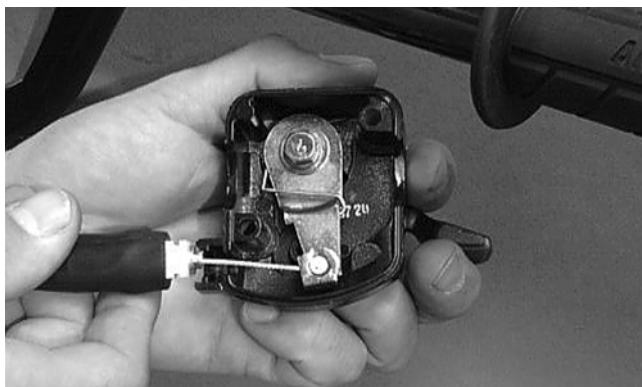

AF676D

3. Remove the cap screw, lock washer, and washer securing the actuator arm to the throttle control lever.

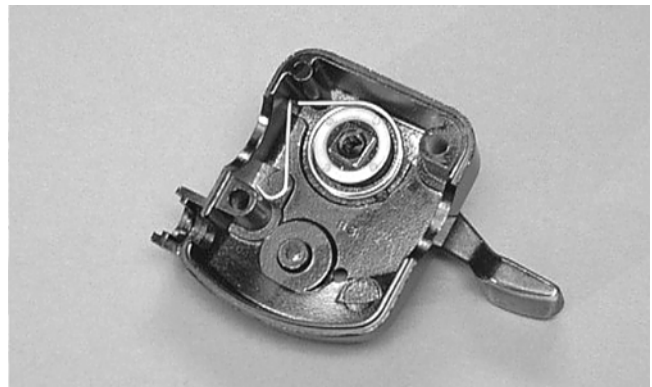

AF678D

INSTALLING

1. Place the return spring into the throttle control; then place the bushing and actuator arm into position. Secure with the cap screw, lock washer, and washer.

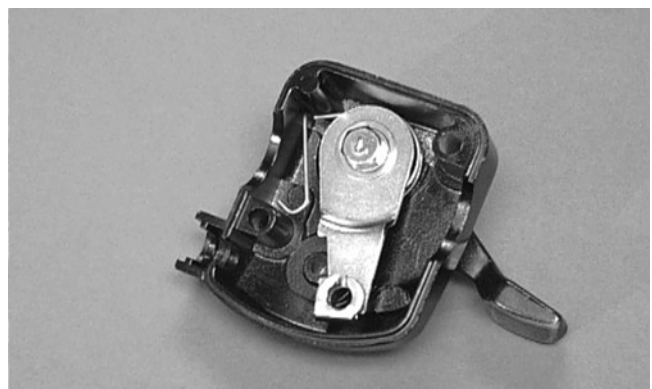

AF679D

2. Using a pair of needle-nose pliers, place the spring into position on the actuator arm.

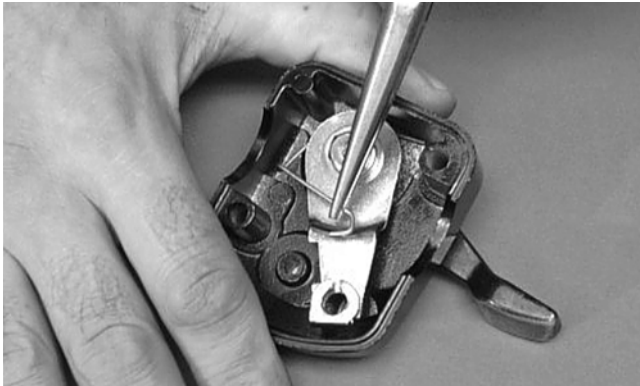

AF680D

3. Place the two halves of the throttle control onto the handlebars and secure with the two machine screws.

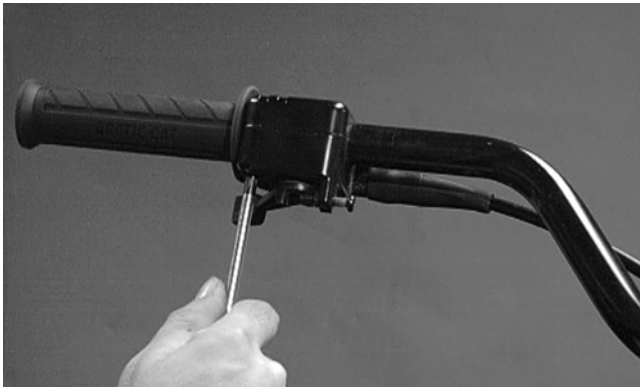

AL610D

ADJUSTING

To adjust the throttle cable, see Section 2.

Reverse Selector/Lock

REMOVING

1. Remove the reverse selector knob mounting screw; then remove the cap screw securing the lower cable housing to the reverse cable bracket.
2. Disconnect the cable end from the reverse lock lever; then remove the cable assembly.

INSTALLING

1. Engage the lower cable end in the reverse lock lever; then attach the cable housing to the reverse cable bracket and tighten the cap screw securely.
2. Route the cable along the upper right frame tube; then attach the reverse selector knob to the frame with the mounting screw and tighten securely.
3. Replace any cable ties that were removed.

SECTION 10 - AIDS FOR MAINTENANCE

TABLE OF CONTENTS

Torque Specifications	10-2
Torque Conversions	10-3
Tightening Torque (General Bolts)	10-3

Torque Specifications

DRIVE TRAIN COMPONENTS			
Part	Part Bolted To	Torque kg-m ft-lb	
Engine Mounting Bolt	Frame	6.6	48
Engine Mounting Bracket Cap Screws	Frame	2.6	19
Rear Axle Housing	Swing Arm	10	72
Hub Nut	Front/Rear	6	43.5
Wheel Lug Nuts	Hub	6	43.5
Rear Driven Sprocket Mounting Cap Screw*	Driven Sprocket Hub	5.4	39
Rear Axle Nut*	Axle	18	130
Engine Drive Sprocket Cap Screw*	Output Shaft	1	7
EXHAUST COMPONENTS			
Exhaust Pipe	Engine	2.3	16.5
Muffler Connection Bolt	Exhaust Pipe	2.3	16.5
Muffler Mounting Bolt	Frame	2.3	16.5
ELECTRICAL COMPONENTS			
Neutral Switch Cap Screw	Engine	0.7	5
Cooling Fan Thermo-Switch	Radiator	2	14.5
Engine Coolant Temperature Switch	Cylinder Head	1.2	9
Starter Motor Lead Cable Nut	Starter	0.6	4
Starter Motor Through-Bolt	Right-Side Cover	1.2	9
STEERING COMPONENTS			
Handlebar Clamp Cap Screw	Steering Head	2.6	19
Steering Post Holder Cap Screw	Frame	2.3	16.5
Steering Post Nut	Steering Post	4.8	35
Upper And Lower Ball Joint Nuts	Steering Knuckle	2.9	21
Tie Rod End Nut	Steering Knuckle	2.9	21
Tie Rod Lock Nut	Tie Rod	2.9	21
BRAKE COMPONENTS			
Brake Hose Union Bolt	Master Cylinders/ Calipers	2.3	16.5
Brake Disc Cap Screw* (Front/Rear)	Hub (F)/Flange (R)	2.3	16.5
Brake Air Bleeder Valve	Caliper	0.6	4
Brake Caliper Mounting Cap Screw	Steering Knuckle/ Swing Arm	2.6	19
Brake Master Cylinder (Front/Rear)	Handlebar/Frame	1	7
Brake Caliper Holder Pin (Front/Rear)	Brake Caliper	1.8	13
Brake Caliper Slide Pin (Front/Rear)	Brake Caliper	2.3	16.5
Front Brake Pipe Nut	Brake Line/Junction Block	1.6	11.5
Brake Caliper (Rear)	Swing-Arm Housing	2.6	19
Brake Pad Mounting Pins	Caliper	1.8	13
Rear Master Cylinder Push Rod Lock Nut	Push Rod	1.8	13
Rear Brake Pedal Nut *	Frame	1.1	8
Parking Brake Cap Screw	Caliper	2.8	20
Parking Brake Adjuster Lock Nut	Caliper	1.8	13

CHASSIS COMPONENTS			
Part	Part Bolted To	Torque kg-m ft-lb	
Footrest Mounting Cap Screw *	Frame	5.5	40
SUSPENSION COMPONENTS (Front)			
A-Arm Pivot Nut	Frame	6.5	47
Front Shock Absorber Mounting Nut* (Upper/Lower)	Frame	5.8	43
SUSPENSION COMPONENTS (Rear)			
Swing Arm Pivot Nut	Frame	9.5	69
Rear Shock Absorber Mounting Nut (Upper/Lower)	Frame/Swing Arm	6	43.5
Rear Swing Arm Cap Screw	Nut Plate	10	72.5
Front Arm Nut	Front Arm	7.7	56
Rear Arm Nut	Rear Arm	7.7	56
ENGINE/TRANSMISSION			
Valve Cover	Cylinder Head	1.4	10
Spark Plug	Cylinder Head	1.1	8
Cylinder Head	10 mm 6 mm Cylinder	4.65 1	33.5 7
Oil Galley Plug	Cylinder Head	1.4	10
Cylinder Nut	Crankcase	1	7
Camshaft Journal	Cylinder Head	1	7
Balancer Driven Gear	Balancer Shaft	5	36
Primary Drive Gear	Driveshaft	13.9	101
Magneto Rotor/Flywheel	Crankshaft	12	87
Clutch Sleeve Hub	Primary Drive	7	50.5
Crankcase Cap Screw	Crankcase	1.1	8
Engine Oil Level Plug	Crankcase	0.6	4
Engine Oil Drain	Crankcase	2.1	15
Engine Oil Drain	Oil Tank	1.15	8.5
Shift Arm Stopper*	Left Case	1.9	14
Shift Cam Driven Gear	Shifter Shaft	2.4	17
Camshaft Chain Tensioner Adjuster	Cam Chain Tensioner	1	7
Camshaft Chain Tensioner Mounting	Cylinder Head	1	7
Camshaft Chain Tension Spring Holder Plug	Cam Chain Tensioner	3	22
Oil Hose Union Bolt	Crankcase	2.3	16.5
Timing Plug	Left Case	2.3	16.5
Fuel Valve	Gas Tank	0.4	3

* w/Red Loctite #271

Torque Conversions

ft-lb	kg-m	ft-lb	kg-m	ft-lb	kg-m	ft-lb	kg-m	ft-lb	kg-m
1	0.1	21	2.9	41	5.7	61	8.4	81	11.2
2	0.3	22	3.0	42	5.8	62	8.6	82	11.3
3	0.4	23	3.2	43	5.8	63	8.7	83	11.5
4	0.6	24	3.3	44	6.1	64	8.9	84	11.6
5	0.7	25	3.5	45	6.2	65	9.0	85	11.8
6	0.8	26	3.6	46	6.4	66	9.1	86	11.9
7	1.0	27	3.7	47	6.5	67	9.3	87	12.0
8	1.1	28	3.9	48	6.6	68	9.4	88	12.2
9	1.2	29	4.0	49	6.8	69	9.5	89	12.3
10	1.4	30	4.2	50	6.9	70	9.7	90	12.5
11	1.5	31	4.3	51	7.1	71	9.8	91	12.6
12	1.7	32	4.4	52	7.2	72	10.0	92	12.8
13	1.8	33	4.6	53	7.3	73	10.1	93	12.9
14	1.9	34	4.7	54	7.5	74	10.2	94	13.0
15	2.1	35	4.8	55	7.6	75	10.4	95	13.1
16	2.2	36	5.0	56	7.7	76	10.5	96	13.3
17	2.4	37	5.1	57	7.9	77	10.7	97	13.4
18	2.5	38	5.3	58	8.0	78	10.8	98	13.6
19	2.6	39	5.4	59	8.2	79	10.9	99	13.7
20	2.8	40	5.5	60	8.3	80	11.1	100	13.8

Tightening Torque (General Bolts)

Type of Bolt	Thread Diameter A (mm)	Tightening Torque	
		kg-m	ft-lb
(Conventional or 4 Marked Bolt)	5	0.2-0.4	1.5-3.0
	6	0.4-0.7	3.0-5.0
	8	1.0-1.6	7.0-11.5
	10	2.2-3.5	16.0-25.5
(7 Marked Bolt)	5	0.3-0.6	2.0-4.5
	6	0.8-1.2	6.0-8.5
	8	1.8-2.8	13.0-20.0
	10	4.0-6.0	29.0-43.5

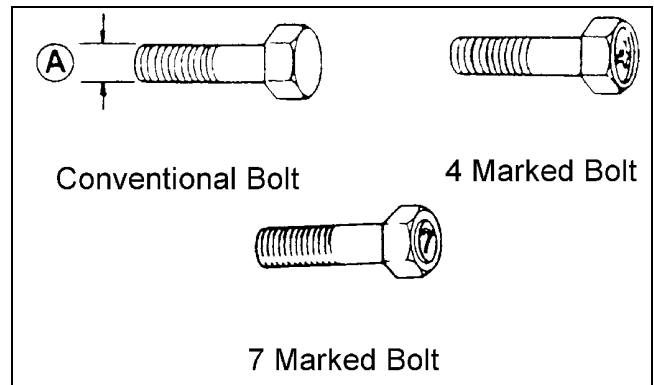

SECTION 11 - TROUBLESHOOTING

TABLE OF CONTENTS

Engine	11-2
Fuel System	11-6
Electrical.....	11-7
Steering/Suspension	11-9
Brakes	11-10

Engine

Problem: Engine will not start or is hard to start (Compression too low)	
Condition	Remedy
1. Valve clearance out of adjustment 2. Valve guides worn - seated poorly 3. Valves mistimed 4. Piston rings worn excessively 5. Cylinder bore worn 6. Spark plug seating poorly 7. Starter motor cranks too slowly - does not turn	1. Adjust clearance 2. Repair - replace guides 3. Time camshafts 4. Replace rings 5. Replace - rebore cylinder 6. Tighten plug 7. See Electrical in this section
Problem: Engine will not start or is hard to start (No spark)	
Condition	Remedy
1. Spark plug fouled 2. Spark plug wet 3. Magneto defective 4. CDI unit defective 5. Ignition coil defective 6. High-tension lead open - shorted	1. Clean - replace plug 2. Clean - dry plug 3. Replace magneto 4. Replace CDI unit 5. Replace ignition coil 6. Replace high tension lead
Problem: Engine will not start or is hard to start (No fuel reaching the carburetor)	
Condition	Remedy
1. Gas tank vent hose obstructed 2. Carburetor inlet needle defective 3. Fuel hose obstructed 4. Fuel screens obstructed 5. Fuel valve clogged - defective	1. Clean vent hose 2. Replace needle 3. Clean - replace hose 4. Clean - replace inlet screen - valve screen 5. Clean - replace valve
Problem: Engine stalls easily	
Condition	Remedy
1. Spark plug fouled 2. Magneto defective 3. CDI unit defective 4. Carburetor jets obstructed 5. Valve clearance out of adjustment	1. Clean plug 2. Replace magneto 3. Replace CDI unit 4. Clean jets 5. Adjust clearance
Problem: Engine noisy (Excessive valve chatter)	
Condition	Remedy
1. Valve clearance too large 2. Valve spring(s) weak - broken 3. Tappet(s) worn 4. Camshaft worn	1. Adjust clearance 2. Replace spring(s) 3. Replace tappet(s) and camshaft(s) 4. Replace camshaft
Problem: Engine noisy (Noise seems to come from piston)	
Condition	Remedy
1. Piston - cylinder worn 2. Combustion chamber carbon buildup 3. Piston pin - piston pin bore worn 4. Piston rings - ring groove(s) worn	1. Replace - service piston - cylinder 2. Clean chamber 3. Replace - service pin - bore 4. Replace rings - piston

Problem: Engine noisy (Noise seems to come from timing chain)	
Condition	Remedy
<ol style="list-style-type: none"> 1. Chain stretched 2. Sprockets worn 3. Tension adjuster malfunctioning 	<ol style="list-style-type: none"> 1. Replace chain 2. Replace sprockets 3. Repair - replace adjuster
Problem: Engine noisy (Noise seems to come from clutch)	
Condition	Remedy
<ol style="list-style-type: none"> 1. Crankshaft splines - bearings worn 2. Countershaft - hub splines worn 3. Clutch plate teeth worn 4. Driven - drive clutch plates distorted - broken 5. Clutch dampers weak 	<ol style="list-style-type: none"> 1. Replace crankshaft - bearings 2. Replace countershaft - hub 3. Replace clutch plate(s) 4. Replace clutch plate(s) 5. Replace dampers
Problem: Engine noisy (Noise seems to come from crankshaft)	
Condition	Remedy
<ol style="list-style-type: none"> 1. Bearing worn - burned 2. Lower rod-end bearing worn - burned 3. Connecting rod side clearance too large 	<ol style="list-style-type: none"> 1. Replace bearing 2. Replace bearing 3. Replace thrust washer(s)
Problem: Engine noisy (Noise seems to come from transmission)	
Condition	Remedy
<ol style="list-style-type: none"> 1. Gears worn - rubbing 2. Splines worn 3. Primary gears worn - rubbing 4. Bearings worn 5. Bushing worn 	<ol style="list-style-type: none"> 1. Replace gears 2. Replace shaft(s) 3. Replace gears 4. Replace bearings 5. Replace bushing
Problem: Engine noisy (Noise seems to come from secondary-transmission/left-side cover)	
Condition	Remedy
<ol style="list-style-type: none"> 1. Gears - shaft(s) worn 2. Bearing(s)/bushing(s) damaged 	<ol style="list-style-type: none"> 1. Replace gears - shafts 2. Replace bearing(s)/bushing(s)
Problem: Clutch slipping	
Condition	Remedy
<ol style="list-style-type: none"> 1. Clutch cable out of adjustment - loss of freeplay 2. Clutch springs weak 3. Pressure disc worn - distorted 4. Clutch plates (driven - drive) distorted 	<ol style="list-style-type: none"> 1. Adjust clutch cable 2. Replace springs 3. Replace disc 4. Replace plates
Problem: Clutch dragging	
Condition	Remedy
<ol style="list-style-type: none"> 1. Clutch cable out of adjustment - too much free-play 2. Clutch springs weak 3. Pressure disc - clutch plates distorted 4. Clutch release mechanism worn - damaged 	<ol style="list-style-type: none"> 1. Adjust cable 2. Replace springs 3. Replace disc - plates 4. Adjust - replace mechanism
Problem: Transmission will not shift	
Condition	Remedy
<ol style="list-style-type: none"> 1. Gearshift cam broken 2. Gearshift forks distorted 3. Gearshift shaft worn 4. Clutch cable out of adjustment 5. Reverse selector cable adjusted improperly 	<ol style="list-style-type: none"> 1. Replace cam 2. Replace forks 3. Replace shaft 4. Adjust cable 5. Adjust cable

Problem: Transmission will not shift back	
Condition	Remedy
<ol style="list-style-type: none"> 1. Reverse shift cam broken 2. Shift shafts rubbing - sticking 3. Gearshift forks distorted - worn 4. Gearshift lever return spring broken - damaged 5. Clutch cable out of adjustment 	<ol style="list-style-type: none"> 1. Replace cam 2. Repair shafts 3. Replace forks 4. Replace spring 5. Adjust cable
Problem: Transmission jumps out of gear	
Condition	Remedy
<ol style="list-style-type: none"> 1. Shifting gears (driveshaft - countershaft) worn 2. Gearshift forks distorted - worn 3. Cam stopper spring (gearshift cam) weak 4. Gearshift lever stopper pin worn 	<ol style="list-style-type: none"> 1. Replace gears 2. Replace forks 3. Replace spring 4. Replace pin
Problem: Engine idles poorly	
Condition	Remedy
<ol style="list-style-type: none"> 1. Valve clearance out of adjustment 2. Valve seating poor 3. Valve guides defective 4. Tappet(s) worn 5. Magneto defective 6. CDI unit defective 7. Spark plug fouled - gap too wide 8. Ignition coil defective 9. Float out of adjustment 10. Jets obstructed 11. Pilot screw setting improper 	<ol style="list-style-type: none"> 1. Adjust clearance 2. Replace - service seats - valves 3. Replace guides 4. Replace tappet(s) and camshaft(s) 5. Replace magneto 6. Replace CDI unit 7. Adjust gap - replace plug 8. Replace ignition coil 9. Adjust float height 10. Clean jets 11. Adjust pilot screw
Problem: Engine runs poorly at high speed	
Condition	Remedy
<ol style="list-style-type: none"> 1. Timing advance circuit malfunctioning 2. Valve springs weak 3. Valve timing incorrect 4. Cams worn 5. Spark plug gap too narrow 6. Ignition coil defective 7. Float level too low 8. Air cleaner element obstructed 9. Fuel hose obstructed 	<ol style="list-style-type: none"> 1. Replace CDI unit 2. Replace springs 3. Reset timing 4. Replace cams 5. Adjust gap 6. Replace ignition coil 7. Adjust float height 8. Clean element 9. Clean - replace hose
Problem: Exhaust smoke dirty or heavy	
Condition	Remedy
<ol style="list-style-type: none"> 1. Piston rings - cylinder worn 2. Valve guides worn 3. Cylinder wall scored - scuffed 4. Valve stems worn 5. Stem seals defective 	<ol style="list-style-type: none"> 1. Replace - service rings - cylinder 2. Replace guides 3. Replace - service cylinder 4. Replace valves 5. Replace seals

Problem: Engine lacks power	
Condition	Remedy
<ol style="list-style-type: none"> 1. Valve clearance incorrect 2. Valve springs weak 3. Valve timing out of adjustment 4. Piston ring(s) - cylinder worn 5. Valve seating poor 6. Spark plug fouled 7. Tappet(s) worn 8. Spark plug gap incorrect 9. Carburetor jets obstructed 10. Float level out of adjustment 11. Air cleaner element obstructed 12. Oil (in the engine) overfilled - contaminated 13. Intake manifold leaking air 14. Cam chain worn 	<ol style="list-style-type: none"> 1. Adjust clearance 2. Replace springs 3. Adjust timing 4. Replace - service rings - cylinder 5. Repair seats 6. Clean - replace plug 7. Replace tappet(s) and camshaft(s) 8. Adjust gap - replace plug 9. Clean jets 10. Adjust float height 11. Clean element 12. Drain excess oil - change oil 13. Tighten - replace manifold 14. Replace cam chain
Problem: Engine overheats	
Condition	Remedy
<ol style="list-style-type: none"> 1. Carbon deposit (piston crown) excessive 2. Oil low 3. Octane low - gasoline poor 4. Oil pump defective 5. Oil circuit obstructed 6. Gasoline level (in float chamber) too low 7. Intake manifold leaking air 8. Coolant level low 9. Fan malfunctioning 10. Fan switch malfunctioning 11. Thermostat stuck - closed 12. Radiator hoses - cap damaged - obstructed 	<ol style="list-style-type: none"> 1. Clean piston 2. Add oil 3. Drain - replace gasoline 4. Replace pump 5. Clean circuit 6. Adjust float height 7. Tighten - replace manifold 8. Fill - examine system for leaks 9. Check fan fuse - replace fan 10. Replace fan switch 11. Replace thermostat 12. Clear obstruction - replace cap - hoses

Fuel System

Problem: Starting impaired	
Condition	Remedy
<ol style="list-style-type: none"> 1. Starter jet obstructed 2. Starter jet passage obstructed 3. Starter body - carburetor leaking air 4. Starter valve not operating properly 	<ol style="list-style-type: none"> 1. Clean jet 2. Clean passage 3. Tighten - adjust - replace gasket 4. Check - adjust valve
Problem: Idling or low speed impaired	
Condition	Remedy
<ol style="list-style-type: none"> 1. Slow jet obstructed - loose 2. Slow jet outlet obstructed 3. Pilot screw setting incorrect 4. Starter valve not fully closed 5. Float height incorrect 	<ol style="list-style-type: none"> 1. Clean - tighten jet 2. Clean outlet 3. Adjust screw 4. Adjust valve 5. Adjust float height
Problem: Medium or high speed impaired	
Condition	Remedy
<ol style="list-style-type: none"> 1. Main jet obstructed 2. Needle jet obstructed 3. Throttle vacuum piston not operating properly 4. Filter obstructed 5. Float height incorrect 6. Starter valve not fully closed 	<ol style="list-style-type: none"> 1. Clean main jet 2. Clean needle jet 3. Check piston operation 4. Clean filter 5. Adjust float height 6. Adjust valve
Problem: Overflow and fuel level fluctuations	
Condition	Remedy
<ol style="list-style-type: none"> 1. Float valve worn - damaged 2. Float valve spring broken 3. Float cracked - fuel-soaked 4. Float valve dirty 5. Float height too high - too low 	<ol style="list-style-type: none"> 1. Replace valve 2. Replace spring 3. Replace float 4. Clean valve 5. Adjust float height

Electrical

Problem: Spark absent or weak	
Condition	Remedy
<ol style="list-style-type: none"> 1. Ignition coil defective 2. Spark plug defective 3. Magneto defective 4. CDI unit defective 5. Pick-up coil defective 	<ol style="list-style-type: none"> 1. Replace ignition coil 2. Replace plug 3. Replace magneto 4. Replace CDI unit 5. Replace pick-up coil
Problem: Spark plug fouled with carbon	
Condition	Remedy
<ol style="list-style-type: none"> 1. Mixture too rich 2. Idling RPM too high 3. Gasoline incorrect 4. Air cleaner element dirty 5. Spark plug incorrect (too cold) 6. Valve seals cracked - missing 7. Oil rings worn - broken 	<ol style="list-style-type: none"> 1. Adjust carburetor 2. Adjust carburetor 3. Change to correct gasoline 4. Clean element 5. Replace plug 6. Replace seals 7. Replace rings
Problem: Spark plug electrodes overheat or burn	
Condition	Remedy
<ol style="list-style-type: none"> 1. Spark plug incorrect (too hot) 2. Engine overheats 3. Spark plug loose 4. Mixture too lean 	<ol style="list-style-type: none"> 1. Replace plug 2. Service cooling system 3. Tighten plug 4. Adjust carburetor
Problem: Magneto does not charge	
Condition	Remedy
<ol style="list-style-type: none"> 1. Lead wires/connections shorted - loose - open 2. Magneto coils shorted - grounded - open 3. Regulator/rectifier shorted - punctured 	<ol style="list-style-type: none"> 1. Repair - replace - tighten lead wires 2. Replace magneto coils 3. Replace regulator/rectifier
Problem: Magneto charges, but charging rate is below the specification	
Condition	Remedy
<ol style="list-style-type: none"> 1. Lead wires shorted - open - loose (at terminals) 2. Stator coils (magneto) grounded - open 3. Regulator/rectifier defective 4. Cell plates (battery) defective 	<ol style="list-style-type: none"> 1. Repair - tighten lead wires 2. Replace stator coils 3. Replace regulator/rectifier 4. Replace battery
Problem: Magneto overcharges	
Condition	Remedy
<ol style="list-style-type: none"> 1. Internal battery short circuited 2. Regulator/rectifier resistor damaged - defective 3. Regulator/rectifier poorly grounded 	<ol style="list-style-type: none"> 1. Replace battery 2. Replace resistor 3. Clean - tighten ground connection
Problem: Charging unstable	
Condition	Remedy
<ol style="list-style-type: none"> 1. Lead wire intermittently shorting 2. Magneto internally shorted 3. Regulator/rectifier defective 	<ol style="list-style-type: none"> 1. Replace lead wire 2. Replace magneto 3. Replace regulator/rectifier

Problem: Starter button not effective	
Condition	Remedy
<ol style="list-style-type: none"> 1. Battery charge low 2. Switch contacts defective 3. Starter motor brushes not seating 4. Starter relay defective 5. Emergency stop - ignition switch off 6. Wiring connections loose - disconnected 7. Clutch position switch defective 	<ol style="list-style-type: none"> 1. Recharge - replace battery 2. Replace switch 3. Repair - replace brushes 4. Replace relay 5. Turn on switches 6. Connect - tighten - repair connections 7. Replace switch
Problem: Battery discharges too rapidly	
Condition	Remedy
<ol style="list-style-type: none"> 1. Electrical load too high 2. Battery short-circuited 	<ol style="list-style-type: none"> 1. Reduce electrical load 2. Replace battery
Problem: Battery polarity reversed	
Condition	Remedy
<ol style="list-style-type: none"> 1. Battery incorrectly connected 	<ol style="list-style-type: none"> 1. Reverse connections - replace battery



Steering/Suspension

Problem: Handling too heavy or stiff	
Condition	Remedy
<ol style="list-style-type: none"> 1. Front wheel alignment incorrect 2. Lubrication inadequate 3. Tire inflation pressure incorrect 4. Tie rod ends seizing 5. Linkage connections seizing 	<ol style="list-style-type: none"> 1. Adjust alignment 2. Lubricate appropriate components 3. Adjust pressure 4. Replace tie rod ends 5. Repair - replace connections
Problem: Steering oscillation	
Condition	Remedy
<ol style="list-style-type: none"> 1. Tires inflated unequally 2. Wheel(s) wobbly 3. Wheel hub cap screw(s) loose - missing 4. Wheel hub bearing worn - damaged 5. Tie rod ends worn - loose 6. Tires defective - incorrect 7. A-arm bushings damaged 8. Bolts - nuts (frame) loose 	<ol style="list-style-type: none"> 1. Adjust pressure 2. Replace wheel(s) 3. Tighten - replace cap screws 4. Replace bearing 5. Replace - tighten tie rod ends 6. Replace tires 7. Replace bushings 8. Tighten bolts - nuts
Problem: Steering pulling to one side	
Condition	Remedy
<ol style="list-style-type: none"> 1. Tires inflated unequally 2. Front wheel alignment incorrect 3. Wheel hub bearings worn - broken 4. Frame distorted 5. Shock absorber defective 	<ol style="list-style-type: none"> 1. Adjust pressure 2. Adjust alignment 3. Replace bearings 4. Repair - replace frame 5. Replace shock absorber
Problem: Steering impaired	
Condition	Remedy
<ol style="list-style-type: none"> 1. Tire pressure too high 2. Steering linkage connections worn 3. Cap screws (suspension system) loose 4. Toe-in incorrect 	<ol style="list-style-type: none"> 1. Adjust pressure 2. Replace connections 3. Tighten cap screws 4. Set toe-in to specifications
Problem: Tire wear rapid or uneven	
Condition	Remedy
<ol style="list-style-type: none"> 1. Wheel hub bearings worn - loose 2. Front wheel alignment incorrect 	<ol style="list-style-type: none"> 1. Replace bearings 2. Adjust alignment
Problem: Steering noise	
Condition	Remedy
<ol style="list-style-type: none"> 1. Caps screws - nuts loose 2. Wheel hub bearings broken - damaged 3. Lubrication inadequate 	<ol style="list-style-type: none"> 1. Tighten cap screws - nuts 2. Replace bearings 3. Lubricate appropriate components
Problem: Suspension too soft	
Condition	Remedy
<ol style="list-style-type: none"> 1. Spring(s) weak 2. Shock absorber damaged 	<ol style="list-style-type: none"> 1. Replace spring(s) 2. Replace shock absorber

Problem: Suspension too stiff	
Condition	Remedy
1. A-arm-related bushings worn	1. Replace bushings
Problem: Suspension noisy	
Condition	Remedy
1. Cap screws (suspension system) loose 2. A-arm-related bushings worn	1. Tighten cap screws 2. Replace bushings
Problem: Rear wheel oscillation	
Condition	Remedy
1. Rear axle/housing bearings worn - loose 2. Tires defective - incorrect 3. Wheel rim distorted 4. Wheel hub cap screws loose 5. Axle hub nut loose 6. Parking brake adjusted incorrectly 7. Rear suspension swing-arm bushing worn 8. Rear shock absorber damaged 9. Rear axle housing cap screws loose	1. Replace bearings 2. Replace tires 3. Replace rim 4. Tighten cap screws 5. Tighten nut 6. Adjust brake 7. Replace bushing 8. Replace shock absorber 9. Tighten cap screws

Brakes

Problem: Braking poor	
Condition	Remedy
1. Pad worn 2. Pedal free-play excessive 3. Brake fluid leaking 4. Hydraulic system leaking air 5. Master cylinder/brake cylinder seal worn	1. Replace pads 2. Adjust free-play 3. Repair - replace hydraulic system 4. Bleed hydraulic system 5. Replace seal(s)
Problem: Brake lever/pedal travel excessive	
Condition	Remedy
1. Hydraulic system entrapped air 2. Brake fluid low 3. Brake fluid incorrect 4. Piston seal - cup worn	1. Bleed hydraulic system 2. Add fluid to proper level 3. Replace with correct fluid 4. Replace seal - cup
Problem: Brake fluid leaking	
Condition	Remedy
1. Connection joints loose 2. Hose cracked 3. Piston seal worn	1. Tighten joints 2. Replace hose 3. Replace seal